



# THE DATASHEET OF LM324N/PB



## LM124/LM224/LM324/LM2902 Low Power Quad Operational Amplifiers

Check for Samples: [LM124-N](#), [LM224-N](#), [LM2902-N](#), [LM324-N](#)

### FEATURES

- Internally frequency compensated for unity gain
- Large DC voltage gain 100 dB
- Wide bandwidth (unity gain) 1 MHz
  - (temperature compensated)
- Wide power supply range:
  - Single supply 3V to 32V
  - or dual supplies  $\pm 1.5V$  to  $\pm 16V$
- Very low supply current drain (700  $\mu A$ )—essentially independent of supply voltage
- Low input biasing current 45 nA
  - (temperature compensated)
- Low input offset voltage 2 mV
  - and offset current: 5 nA
- Input common-mode voltage range includes ground
- Differential input voltage range equal to the power supply voltage
- Large output voltage swing 0V to  $V^+ - 1.5V$

### DESCRIPTION

The LM124 series consists of four independent, high gain, internally frequency compensated operational amplifiers which were designed specifically to operate from a single power supply over a wide range of voltages. Operation from split power supplies is also possible and the low power supply current drain is independent of the magnitude of the power supply voltage.

Application areas include transducer amplifiers, DC gain blocks and all the conventional op amp circuits which now can be more easily implemented in single power supply systems. For example, the LM124 series can be directly operated off of the standard +5V power supply voltage which is used in digital systems and will easily provide the required interface electronics without requiring the additional  $\pm 15V$  power supplies.

### UNIQUE CHARACTERISTICS

- In the linear mode the input common-mode voltage range includes ground and the output voltage can also swing to ground, even though operated from only a single power supply voltage
- The unity gain cross frequency is temperature compensated
- The input bias current is also temperature compensated

### ADVANTAGES

- Eliminates need for dual supplies
- Four internally compensated op amps in a single package
- Allows directly sensing near GND and  $V_{OUT}$  also goes to GND
- Compatible with all forms of logic
- Power drain suitable for battery operation



Please be aware that an important notice concerning availability, standard warranty, and use in critical applications of Texas Instruments semiconductor products and disclaimers thereto appears at the end of this data sheet.

All trademarks are the property of their respective owners.

**CONNECTION DIAGRAM**

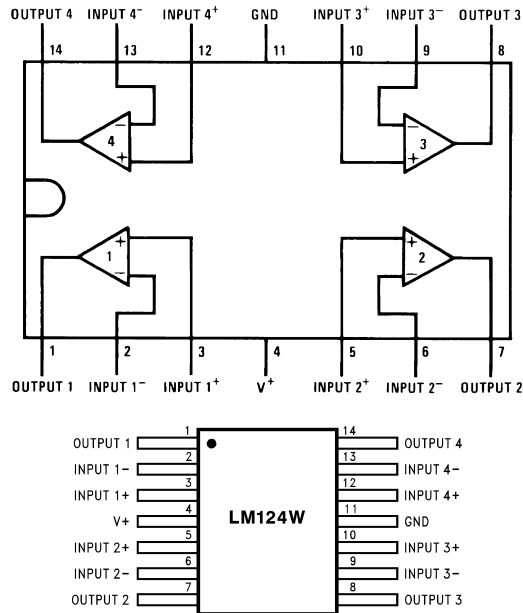

LM124A available per JM38510/11006  
 LM124 available per JM38510/11005  
 See STD Mil DWG 5962R99504 for Radiation Tolerant Device

**Figure 1. Dual-In-Line Package Top View**

**SCHEMATIC DIAGRAM**

(Each Amplifier)

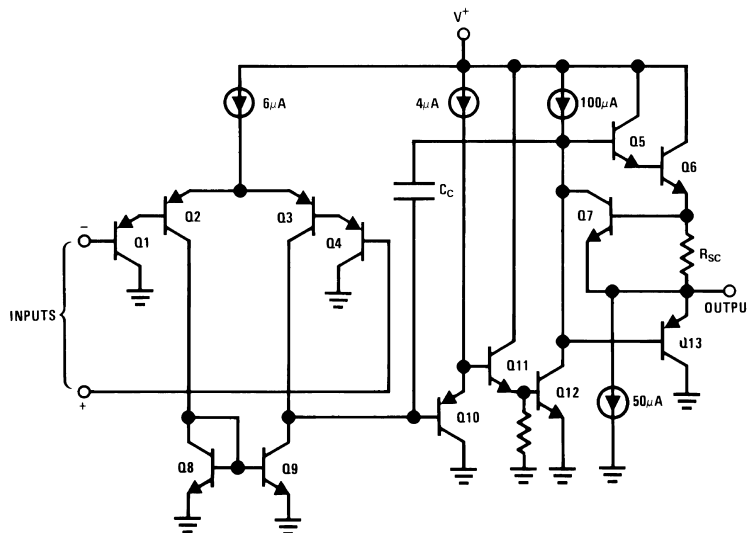

These devices have limited built-in ESD protection. The leads should be shorted together or the device placed in conductive foam during storage or handling to prevent electrostatic damage to the MOS gates.

**ABSOLUTE MAXIMUM RATINGS<sup>(1)</sup>**

	LM124/LM224/LM324	LM2902
	LM124A/LM224A/LM324A	
Supply Voltage, V <sup>+</sup>	32V	26V
Differential Input Voltage	32V	26V
Input Voltage	-0.3V to +32V	-0.3V to +26V
Input Current		
(V <sub>IN</sub> < -0.3V) <sup>(2)</sup>	50 mA	50 mA
Power Dissipation <sup>(3)</sup>		
Molded DIP	1130 mW	1130 mW
Cavity DIP	1260 mW	1260 mW
Small Outline Package	800 mW	800 mW
Output Short-Circuit to GND (One Amplifier) <sup>(4)</sup>		
V <sup>+</sup> ≤ 15V and T <sub>A</sub> = 25°C	Continuous	Continuous
Operating Temperature Range		-40°C to +85°C
LM324/LM324A	0°C to +70°C	
LM224/LM224A	-25°C to +85°C	
LM124/LM124A	-55°C to +125°C	
Storage Temperature Range	-65°C to +150°C	-65°C to +150°C
Lead Temperature (Soldering, 10 seconds)	260°C	260°C
Soldering Information		
Dual-In-Line Package		
Soldering (10 seconds)	260°C	260°C
Small Outline Package		
Vapor Phase (60 seconds)	215°C	215°C
Infrared (15 seconds)	220°C	220°C
See AN-450 "Surface Mounting Methods and Their Effect on Product Reliability" for other methods of soldering surface mount devices.		
ESD Tolerance <sup>(5)</sup>	250V	250V

- (1) Refer to RETS124AX for LM124A military specifications and refer to RETS124X for LM124 military specifications.
- (2) This input current will only exist when the voltage at any of the input leads is driven negative. It is due to the collector-base junction of the input PNP transistors becoming forward biased and thereby acting as input diode clamps. In addition to this diode action, there is also lateral NPN parasitic transistor action on the IC chip. This transistor action can cause the output voltages of the op amps to go to the V<sup>+</sup> voltage level (or to ground for a large overdrive) for the time duration that an input is driven negative. This is not destructive and normal output states will re-establish when the input voltage, which was negative, again returns to a value greater than -0.3V (at 25°C).
- (3) For operating at high temperatures, the LM324/LM324A/LM2902 must be derated based on a +125°C maximum junction temperature and a thermal resistance of 88°C/W which applies for the device soldered in a printed circuit board, operating in a still air ambient. The LM224/LM224A and LM124/LM124A can be derated based on a +150°C maximum junction temperature. The dissipation is the total of all four amplifiers—use external resistors, where possible, to allow the amplifier to saturate or to reduce the power which is dissipated in the integrated circuit.
- (4) Short circuits from the output to V<sup>+</sup> can cause excessive heating and eventual destruction. When considering short circuits to ground, the maximum output current is approximately 40 mA independent of the magnitude of V<sup>+</sup>. At values of supply voltage in excess of +15V, continuous short-circuits can exceed the power dissipation ratings and cause eventual destruction. Destructive dissipation can result from simultaneous shorts on all amplifiers.
- (5) Human body model, 1.5 kΩ in series with 100 pF.

## ELECTRICAL CHARACTERISTICS

V<sup>+</sup> = +5.0V, <sup>(1)</sup>, unless otherwise stated

Parameter	Conditions	LM124A			LM224A			LM324A			Units
		Min	Typ	Max	Min	Typ	Max	Min	Typ	Max	
Input Offset Voltage	<sup>(2)</sup> T <sub>A</sub> = 25°C		1	2		1	3		2	3	mV
Input Bias Current	I <sub>IN(+)</sub> or I <sub>IN(-)</sub> , V <sub>CM</sub> = 0V, <sup>(3)</sup> T <sub>A</sub> = 25°C		20	50		40	80		45	100	nA
Input Offset Current	I <sub>IN(+)</sub> or I <sub>IN(-)</sub> , V <sub>CM</sub> = 0V, T <sub>A</sub> = 25°C		2	10		2	15		5	30	nA
Input Common-Mode	V <sup>+</sup> = 30V, (LM2902, V <sup>+</sup> = 26V), T <sub>A</sub> = 25°C	0		V <sup>+</sup> -1 .5	0		V <sup>+</sup> -1 .5	0		V <sup>+</sup> -1 .5	V
Voltage Range <sup>(4)</sup>	T <sub>A</sub> = 25°C										
Supply Current	Over Full Temperature Range R <sub>L</sub> = ∞ On All Op Amps										mA
	V <sup>+</sup> = 30V (LM2902 V <sup>+</sup> = 26V)		1.5	3		1.5	3		1.5	3	
	V <sup>+</sup> = 5V		0.7	1.2		0.7	1.2		0.7	1.2	
Large Signal	V <sup>+</sup> = 15V, R <sub>L</sub> ≥ 2kΩ, T <sub>A</sub> = 25°C	50	100		50	100		25	100		V/m V
Voltage Gain	(V <sub>O</sub> = 1V to 11V), T <sub>A</sub> = 25°C										
Common-Mode	DC, V <sub>CM</sub> = 0V to V <sup>+</sup> - 1.5V, T <sub>A</sub> = 25°C	70	85		70	85		65	85		dB
Rejection Ratio	T <sub>A</sub> = 25°C										
Power Supply	V <sup>+</sup> = 5V to 30V										
Rejection Ratio	(LM2902, V <sup>+</sup> = 5V to 26V), T <sub>A</sub> = 25°C	65	100		65	100		65	100		dB
Amplifier-to-Amplifier	f = 1 kHz to 20 kHz, T <sub>A</sub> = 25°C		-120			-120			-120		dB
Coupling <sup>(5)</sup>	(Input Referred)										
Output Current	Source V <sub>IN<sup>+</sup></sub> = 1V, V <sub>IN<sup>-</sup></sub> = 0V, V <sup>+</sup> = 15V, V <sub>O</sub> = 2V, T <sub>A</sub> = 25°C	20	40		20	40		20	40		mA
	Sink V <sub>IN<sup>-</sup></sub> = 1V, V <sub>IN<sup>+</sup></sub> = 0V, V <sup>+</sup> = 15V, V <sub>O</sub> = 2V, T <sub>A</sub> = 25°C	10	20		10	20		10	20		
	V <sub>IN<sup>-</sup></sub> = 1V, V <sub>IN<sup>+</sup></sub> = 0V, V <sup>+</sup> = 15V, V <sub>O</sub> = 200 mV, T <sub>A</sub> = 25°C	12	50		12	50		12	50		μA
Short Circuit to Ground	<sup>(6)</sup> V <sup>+</sup> = 15V, T <sub>A</sub> = 25°C		40	60		40	60		40	60	mA
Input Offset Voltage	<sup>(2)</sup>			4			4			5	mV
V <sub>OS</sub> Drift	R <sub>S</sub> = 0Ω		7	20		7	20		7	30	μV/° C
Input Offset Current	I <sub>IN(+)</sub> - I <sub>IN(-)</sub> , V <sub>CM</sub> = 0V			30			30			75	nA
I <sub>OS</sub> Drift	R <sub>S</sub> = 0Ω		10	200		10	200		10	300	pA/° C

- (1) These specifications are limited to -55°C ≤ T<sub>A</sub> ≤ +125°C for the LM124/LM124A. With the LM224/LM224A, all temperature specifications are limited to -25°C ≤ T<sub>A</sub> ≤ +85°C, the LM324/LM324A temperature specifications are limited to 0°C ≤ T<sub>A</sub> ≤ +70°C, and the LM2902 specifications are limited to -40°C ≤ T<sub>A</sub> ≤ +85°C.
- (2) V<sub>O</sub> = 1.4V, R<sub>S</sub> = 0Ω with V<sup>+</sup> from 5V to 30V; and over the full input common-mode range (0V to V<sup>+</sup> - 1.5V) for LM2902, V<sup>+</sup> from 5V to 26V.
- (3) The direction of the input current is out of the IC due to the PNP input stage. This current is essentially constant, independent of the state of the output so no loading change exists on the input lines.
- (4) The input common-mode voltage of either input signal voltage should not be allowed to go negative by more than 0.3V (at 25°C). The upper end of the common-mode voltage range is V<sup>+</sup> - 1.5V (at 25°C), but either or both inputs can go to +32V without damage (+26V for LM2902), independent of the magnitude of V<sup>+</sup>.
- (5) Due to proximity of external components, insure that coupling is not originating via stray capacitance between these external parts. This typically can be detected as this type of capacitance increases at higher frequencies.
- (6) Short circuits from the output to V<sup>+</sup> can cause excessive heating and eventual destruction. When considering short circuits to ground, the maximum output current is approximately 40 mA independent of the magnitude of V<sup>+</sup>. At values of supply voltage in excess of +15V, continuous short-circuits can exceed the power dissipation ratings and cause eventual destruction. Destructive dissipation can result from simultaneous shorts on all amplifiers.

**ELECTRICAL CHARACTERISTICS (continued)**
 $V^+ = +5.0V$ , <sup>(1)</sup>, unless otherwise stated

Parameter		Conditions		LM124A			LM224A			LM324A			Units
				Min	Typ	Max	Min	Typ	Max	Min	Typ	Max	
Input Bias Current		$I_{IN(+)}$ or $I_{IN(-)}$			40	100		40	100		40	200	nA
Input Common-Mode		$V^+ = +30V$		0		$V^+ - 2$	0		$V^+ - 2$	0		$V^+ - 2$	V
Voltage Range <sup>(4)</sup>		(LM2902, $V^+ = 26V$ )											
Large Signal		$V^+ = +15V$ ( $V_O$ Swing = 1V to 11V)											
Voltage Gain		$R_L \geq 2\text{ k}\Omega$		25			25			15			V/mV
Output Voltage	$V_{OH}$	$V^+ = 30V$	$R_L = 2\text{ k}\Omega$	26			26			26			V
Swing		(LM2902, $V^+ = 26V$ )	$R_L = 10\text{ k}\Omega$	27	28		27	28		27	28		
	$V_{OL}$	$V^+ = 5V$ , $R_L = 10\text{ k}\Omega$			5	20		5	20		5	20	mV
Output Current	Source	$V_O = 2V$	$V_{IN}^+ = +1V$ ,	10	20		10	20		10	20		
			$V_{IN}^- = 0V$ ,										mA
			$V^+ = 15V$										
	Sink		$V_{IN}^- = +1V$ ,	10	15		5	8		5	8		
			$V_{IN}^+ = 0V$ ,										
			$V^+ = 15V$										

**ELECTRICAL CHARACTERISTICS**

V<sup>+</sup> = +5.0V, <sup>(1)</sup>, unless otherwise stated

Parameter	Conditions	LM124/LM224			LM324			LM2902			Units
		Min	Typ	Max	Min	Typ	Max	Min	Typ	Max	
Input Offset Voltage	<sup>(2)</sup> T <sub>A</sub> = 25°C		2	5		2	7		2	7	mV
Input Bias Current	I <sub>IN(+)</sub> or I <sub>IN(-)</sub> , V <sub>CM</sub> = 0V, <sup>(3)</sup> T <sub>A</sub> = 25°C		45	150		45	250		45	250	nA
Input Offset Current	I <sub>IN(+)</sub> or I <sub>IN(-)</sub> , V <sub>CM</sub> = 0V, T <sub>A</sub> = 25°C		3	30		5	50		5	50	nA
Input Common-Mode	V <sup>+</sup> = 30V, (LM2902, V <sup>+</sup> = 26V), T <sub>A</sub> = 25°C	0		V <sup>+</sup> -1 .5	0		V <sup>+</sup> -1 .5	0		V <sup>+</sup> -1 .5	V
Voltage Range <sup>(4)</sup>	T <sub>A</sub> = 25°C										
Supply Current	Over Full Temperature Range R <sub>L</sub> = ∞ On All Op Amps										mA
	V <sup>+</sup> = 30V (LM2902 V <sup>+</sup> = 26V)		1.5	3		1.5	3		1.5	3	
	V <sup>+</sup> = 5V		0.7	1.2		0.7	1.2		0.7	1.2	
Large Signal	V <sup>+</sup> = 15V, R <sub>L</sub> ≥ 2kΩ, T <sub>A</sub> = 25°C	50	100		25	100		25	100		V/m V
Voltage Gain	(V <sub>O</sub> = 1V to 11V), T <sub>A</sub> = 25°C										
Common-Mode	DC, V <sub>CM</sub> = 0V to V <sup>+</sup> - 1.5V, T <sub>A</sub> = 25°C	70	85		65	85		50	70		dB
Rejection Ratio	T <sub>A</sub> = 25°C										
Power Supply	V <sup>+</sup> = 5V to 30V										
Rejection Ratio	(LM2902, V <sup>+</sup> = 5V to 26V), T <sub>A</sub> = 25°C	65	100		65	100		50	100		dB
Amplifier-to-Amplifier	f = 1 kHz to 20 kHz, T <sub>A</sub> = 25°C		-120			-120			-120		dB
Coupling <sup>(5)</sup>	(Input Referred)										
Output Current	Source V <sub>IN<sup>+</sup></sub> = 1V, V <sub>IN<sup>-</sup></sub> = 0V, V <sup>+</sup> = 15V, V <sub>O</sub> = 2V, T <sub>A</sub> = 25°C	20	40		20	40		20	40		mA
	Sink V <sub>IN<sup>-</sup></sub> = 1V, V <sub>IN<sup>+</sup></sub> = 0V, V <sup>+</sup> = 15V, V <sub>O</sub> = 2V, T <sub>A</sub> = 25°C	10	20		10	20		10	20		
	V <sub>IN<sup>-</sup></sub> = 1V, V <sub>IN<sup>+</sup></sub> = 0V, V <sup>+</sup> = 15V, V <sub>O</sub> = 200 mV, T <sub>A</sub> = 25°C	12	50		12	50		12	50		μA
Short Circuit to Ground	<sup>(6)</sup> V <sup>+</sup> = 15V, T <sub>A</sub> = 25°C		40	60		40	60		40	60	mA
Input Offset Voltage	<sup>(2)</sup>			7			9			10	mV
V <sub>OS</sub> Drift	R <sub>S</sub> = 0Ω		7			7			7		μV/° C
Input Offset Current	I <sub>IN(+)</sub> - I <sub>IN(-)</sub> , V <sub>CM</sub> = 0V			100			150		45	200	nA
I <sub>OS</sub> Drift	R <sub>S</sub> = 0Ω		10			10			10		pA/° C

- (1) These specifications are limited to -55°C ≤ T<sub>A</sub> ≤ +125°C for the LM124/LM124A. With the LM224/LM224A, all temperature specifications are limited to -25°C ≤ T<sub>A</sub> ≤ +85°C, the LM324/LM324A temperature specifications are limited to 0°C ≤ T<sub>A</sub> ≤ +70°C, and the LM2902 specifications are limited to -40°C ≤ T<sub>A</sub> ≤ +85°C.
- (2) V<sub>O</sub> = 1.4V, R<sub>S</sub> = 0Ω with V<sup>+</sup> from 5V to 30V; and over the full input common-mode range (0V to V<sup>+</sup> - 1.5V) for LM2902, V<sup>+</sup> from 5V to 26V.
- (3) The direction of the input current is out of the IC due to the PNP input stage. This current is essentially constant, independent of the state of the output so no loading change exists on the input lines.
- (4) The input common-mode voltage of either input signal voltage should not be allowed to go negative by more than 0.3V (at 25°C). The upper end of the common-mode voltage range is V<sup>+</sup> - 1.5V (at 25°C), but either or both inputs can go to +32V without damage (+26V for LM2902), independent of the magnitude of V<sup>+</sup>.
- (5) Due to proximity of external components, insure that coupling is not originating via stray capacitance between these external parts. This typically can be detected as this type of capacitance increases at higher frequencies.
- (6) Short circuits from the output to V<sup>+</sup> can cause excessive heating and eventual destruction. When considering short circuits to ground, the maximum output current is approximately 40 mA independent of the magnitude of V<sup>+</sup>. At values of supply voltage in excess of +15V, continuous short-circuits can exceed the power dissipation ratings and cause eventual destruction. Destructive dissipation can result from simultaneous shorts on all amplifiers.

**ELECTRICAL CHARACTERISTICS (continued)**
 $V^+ = +5.0V$ , <sup>(1)</sup>, unless otherwise stated

Parameter		Conditions		LM124/LM224			LM324			LM2902			Units
				Min	Typ	Max	Min	Typ	Max	Min	Typ	Max	
Input Bias Current		$I_{IN(+)}$ or $I_{IN(-)}$			40	300		40	500		40	500	nA
Input Common-Mode		$V^+ = +30V$		0		$V^+ - 2$	0		$V^+ - 2$	0		$V^+ - 2$	V
Voltage Range <sup>(4)</sup>		(LM2902, $V^+ = 26V$ )											
Large Signal		$V^+ = +15V$ ( $V_O$ Swing = 1V to 11V)											
Voltage Gain		$R_L \geq 2\text{ k}\Omega$		25			15			15			V/mV
Output Voltage	$V_{OH}$	$V^+ = 30V$	$R_L = 2\text{ k}\Omega$	26			26			22			V
Swing		(LM2902, $V^+ = 26V$ )	$R_L = 10\text{ k}\Omega$	27	28		27	28		23	24		
	$V_{OL}$	$V^+ = 5V$ , $R_L = 10\text{ k}\Omega$			5	20		5	20		5	100	mV
Output Current	Source	$V_O = 2V$	$V_{IN}^+ = +1V$ ,	10	20		10	20		10	20		
			$V_{IN}^- = 0V$ ,										mA
			$V^+ = 15V$										
	Sink		$V_{IN}^- = +1V$ ,	5	8		5	8		5	8		
			$V_{IN}^+ = 0V$ ,										
			$V^+ = 15V$										

**TYPICAL PERFORMANCE CHARACTERISTICS**

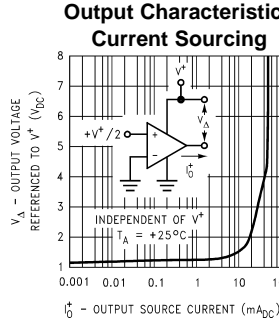
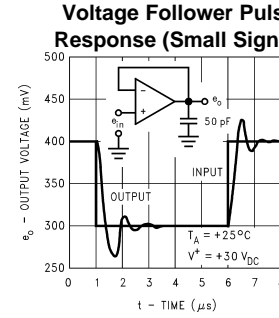
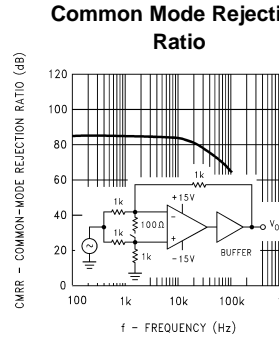
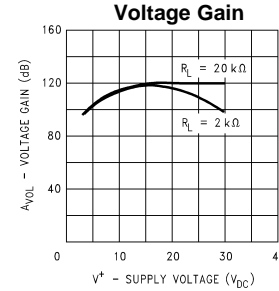
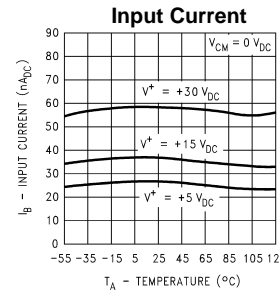
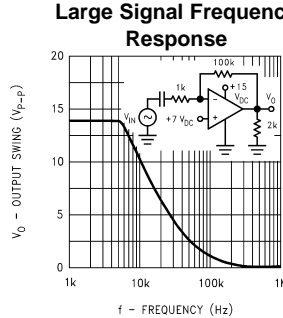
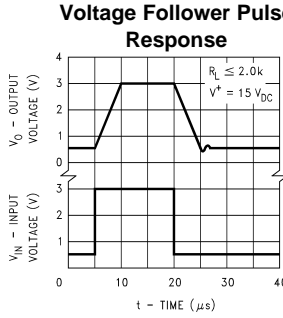
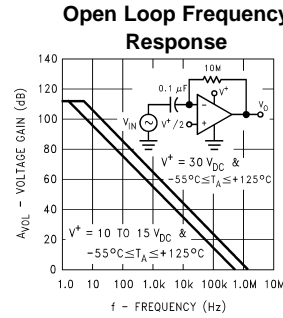
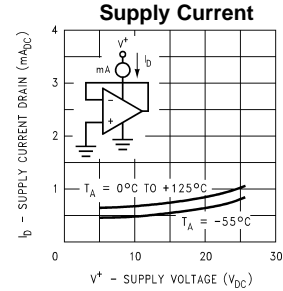
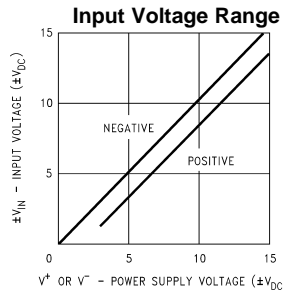

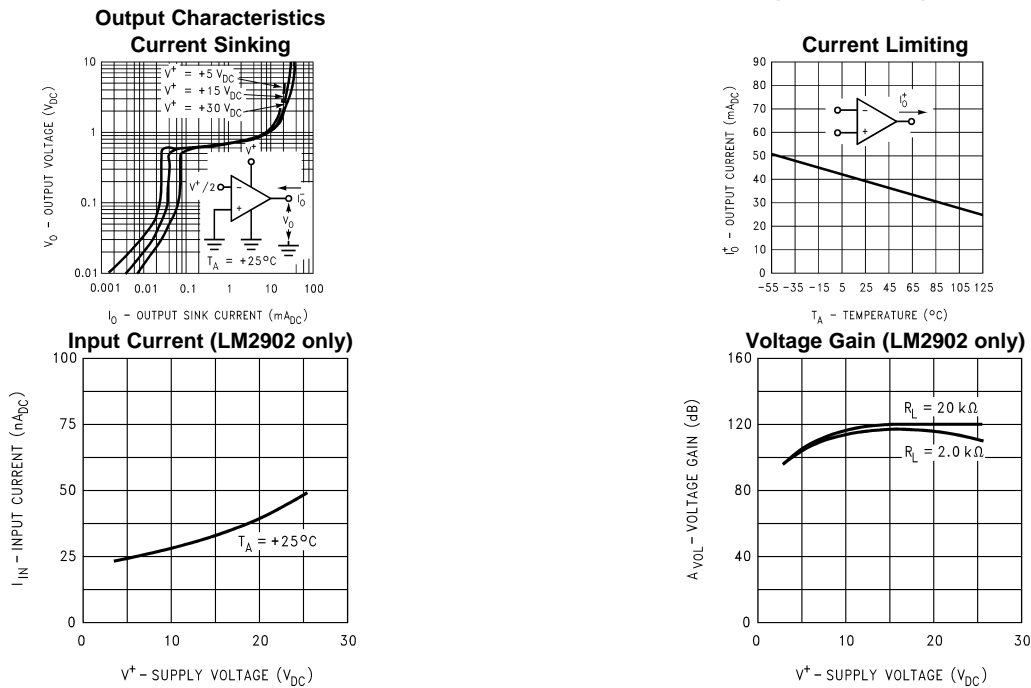
**TYPICAL PERFORMANCE CHARACTERISTICS (continued)**

**APPLICATION HINTS**

The LM124 series are op amps which operate with only a single power supply voltage, have true-differential inputs, and remain in the linear mode with an input common-mode voltage of  $0 V_{DC}$ . These amplifiers operate over a wide range of power supply voltage with little change in performance characteristics. At  $25^\circ C$  amplifier operation is possible down to a minimum supply voltage of  $2.3 V_{DC}$ .

The pinouts of the package have been designed to simplify PC board layouts. Inverting inputs are adjacent to outputs for all of the amplifiers and the outputs have also been placed at the corners of the package (pins 1, 7, 8, and 14).

Precautions should be taken to insure that the power supply for the integrated circuit never becomes reversed in polarity or that the unit is not inadvertently installed backwards in a test socket as an unlimited current surge through the resulting forward diode within the IC could cause fusing of the internal conductors and result in a destroyed unit.

Large differential input voltages can be easily accommodated and, as input differential voltage protection diodes are not needed, no large input currents result from large differential input voltages. The differential input voltage may be larger than  $V^+$  without damaging the device. Protection should be provided to prevent the input voltages from going negative more than  $-0.3 V_{DC}$  (at  $25^\circ C$ ). An input clamp diode with a resistor to the IC input terminal can be used.

To reduce the power supply drain, the amplifiers have a class A output stage for small signal levels which converts to class B in a large signal mode. This allows the amplifiers to both source and sink large output currents. Therefore both NPN and PNP external current boost transistors can be used to extend the power capability of the basic amplifiers. The output voltage needs to raise approximately 1 diode drop above ground to bias the on-chip vertical PNP transistor for output current sinking applications.

For ac applications, where the load is capacitively coupled to the output of the amplifier, a resistor should be used, from the output of the amplifier to ground to increase the class A bias current and prevent crossover distortion.

Where the load is directly coupled, as in dc applications, there is no crossover distortion.

Capacitive loads which are applied directly to the output of the amplifier reduce the loop stability margin. Values of 50 pF can be accommodated using the worst-case non-inverting unity gain connection. Large closed loop gains or resistive isolation should be used if larger load capacitance must be driven by the amplifier.

The bias network of the LM124 establishes a drain current which is independent of the magnitude of the power supply voltage over the range of from 3  $V_{DC}$  to 30  $V_{DC}$ .

Output short circuits either to ground or to the positive power supply should be of short time duration. Units can be destroyed, not as a result of the short circuit current causing metal fusing, but rather due to the large increase in IC chip dissipation which will cause eventual failure due to excessive junction temperatures. Putting direct short-circuits on more than one amplifier at a time will increase the total IC power dissipation to destructive levels, if not properly protected with external dissipation limiting resistors in series with the output leads of the amplifiers. The larger value of output source current which is available at 25°C provides a larger output current capability at elevated temperatures (see typical performance characteristics) than a standard IC op amp.

The circuits presented in the section on typical applications emphasize operation on only a single power supply voltage. If complementary power supplies are available, all of the standard op amp circuits can be used. In general, introducing a pseudo-ground (a bias voltage reference of  $V^+/2$ ) will allow operation above and below this value in single power supply systems. Many application circuits are shown which take advantage of the wide input common-mode voltage range which includes ground. In most cases, input biasing is not required and input voltages which range to ground can easily be accommodated.

**TYPICAL SINGLE-SUPPLY APPLICATIONS**

( $V^+ = 5.0 V_{DC}$ )

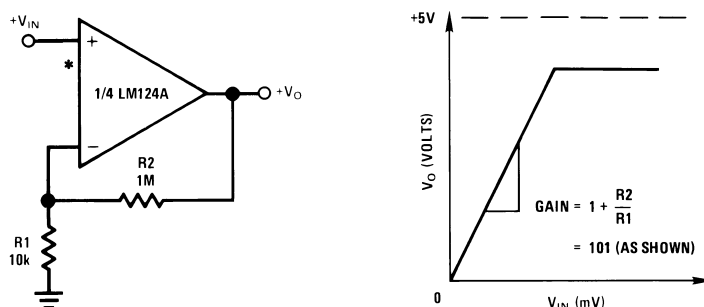

\*R not needed due to temperature independent  $I_{IN}$

**Figure 2. Non-Inverting DC Gain (0V Input = 0V Output)**

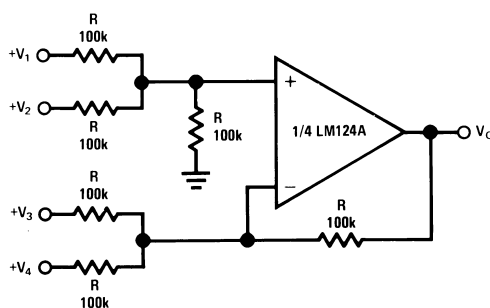

Where:  $V_0 = V_1 + V_2 - V_3 - V_4$   
 $(V_1 + V_2) \geq (V_3 + V_4)$  to keep  $V_0 > 0 V_{DC}$

**Figure 3. DC Summing Amplifier**  
 ( $V_{IN}'S \geq 0 V_{DC}$  and  $V_0 \geq V_{DC}$ )

( $V^+ = 5.0 V_{DC}$ )

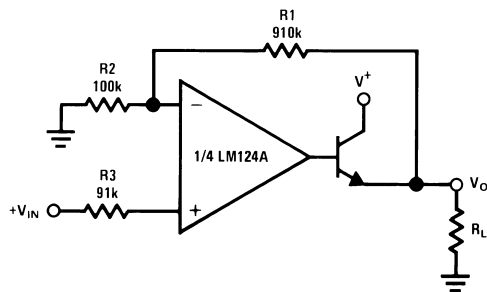

$V_0 = 0 V_{DC}$  for  $V_{IN} = 0 V_{DC}$   
 $A_V = 10$

Figure 4. Power Amplifier

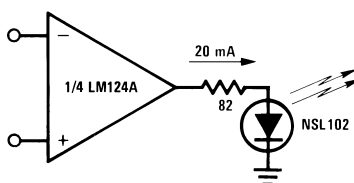
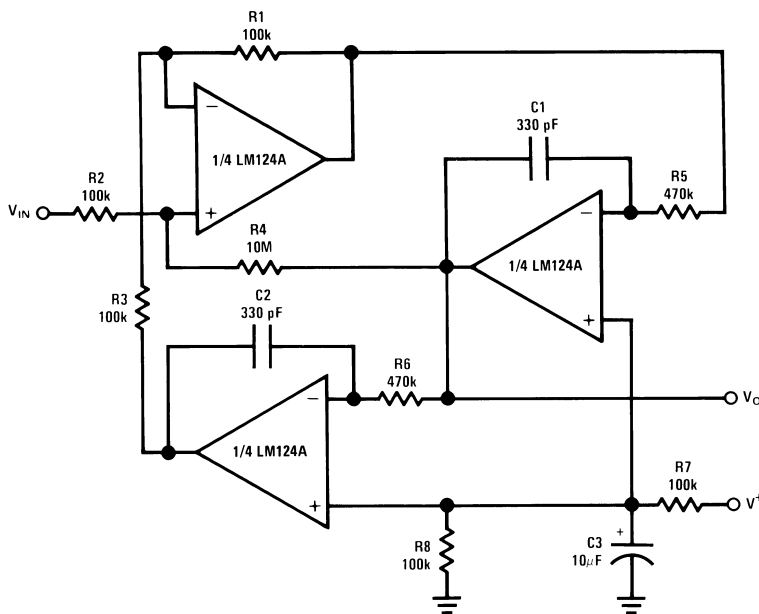

Figure 5. LED Driver



$f_0 = 1 \text{ kHz}$   
 $Q = 50$   
 $A_V = 100 \text{ (40 dB)}$

Figure 6. "BI-QUAD" RC Active Bandpass Filter

( $V^+ = 5.0 V_{DC}$ )

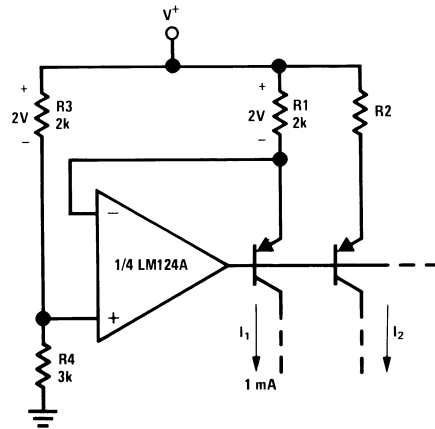

$$I_2 = \left( \frac{R1}{R2} \right) I_1$$

Figure 7. Fixed Current Sources

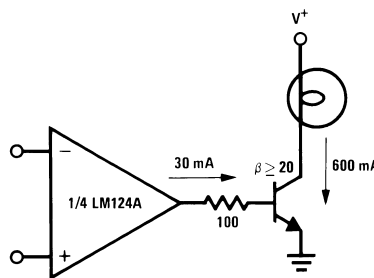
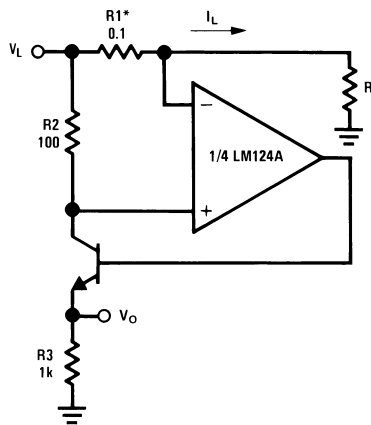

Figure 8. Lamp Driver



$$V_O = \frac{1V(I_L)}{1A}$$

$V_L \leq V^+ - 2V$   
 \*(Increase R1 for  $I_L$  small)

Figure 9. Current Monitor

( $V^+ = 5.0 V_{DC}$ )

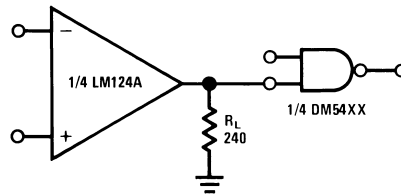

Figure 10. Driving TTL

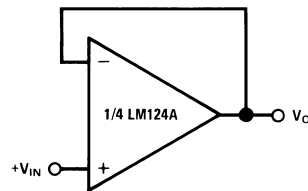

Figure 11. Voltage Follower

Figure 12.

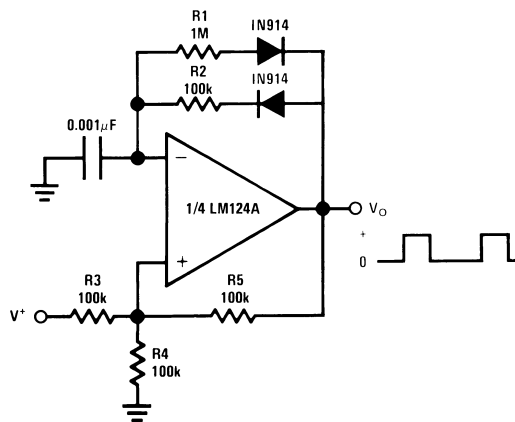

Figure 13. Pulse Generator

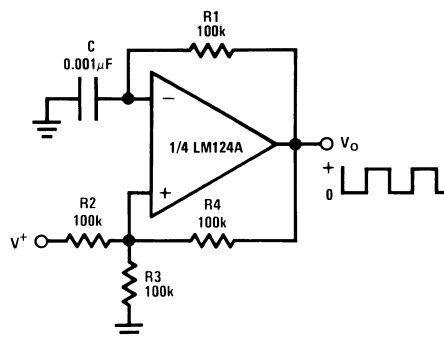

Figure 14. Squarewave Oscillator

( $V^+ = 5.0 V_{DC}$ )

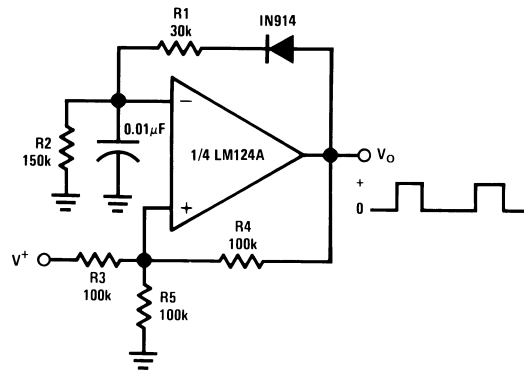
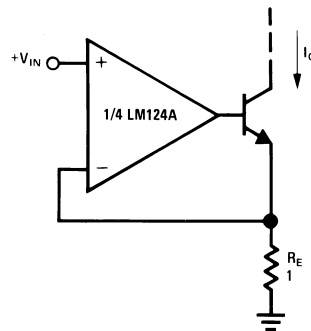

Figure 15. Pulse Generator



$I_O = 1 \text{ amp/volt } V_{IN}$   
(Increase  $R_E$  for  $I_O$  small)

Figure 16. High Compliance Current Sink

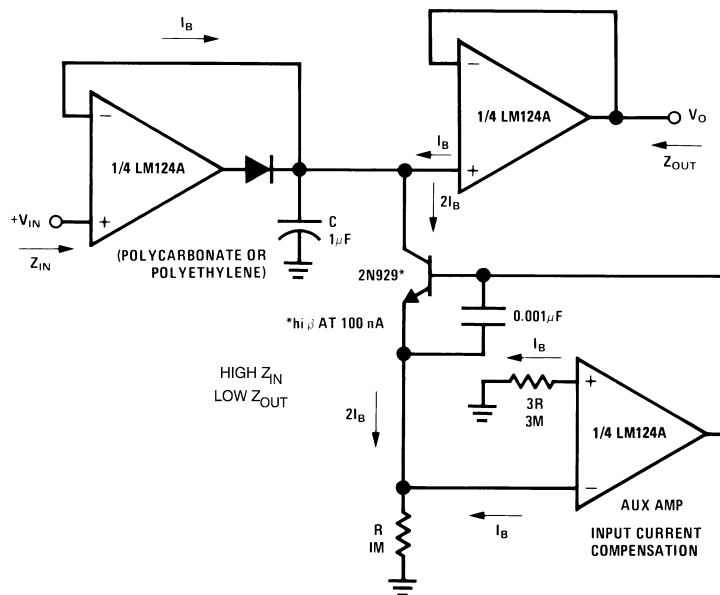

Figure 17. Low Drift Peak Detector

( $V^+ = 5.0 V_{DC}$ )

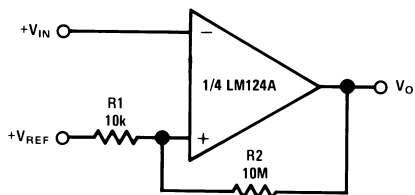
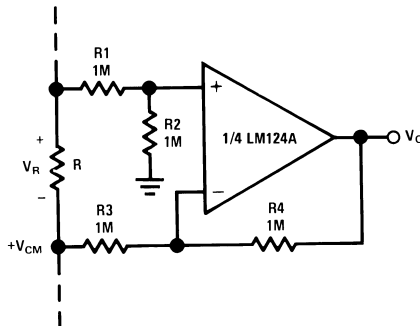
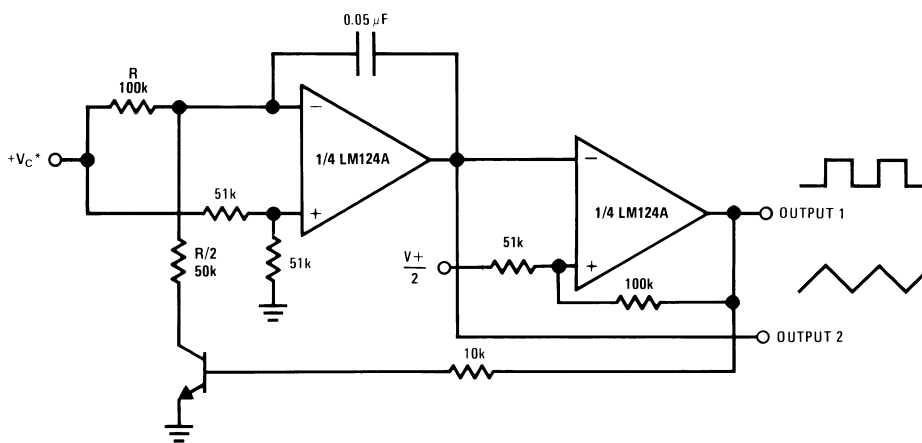

Figure 18. Comparator with Hysteresis



$V_O = V_R$

Figure 19. Ground Referencing a Differential Input Signal



\*Wide control voltage range:  $0 V_{DC} \leq V_C \leq 2 (V^+ - 1.5 V_{DC})$

Figure 20. Voltage Controlled Oscillator Circuit

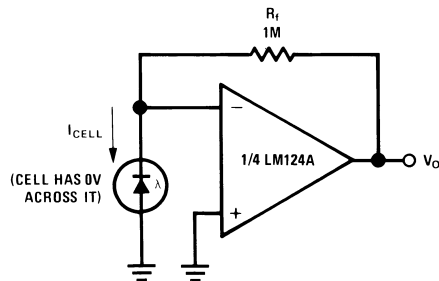
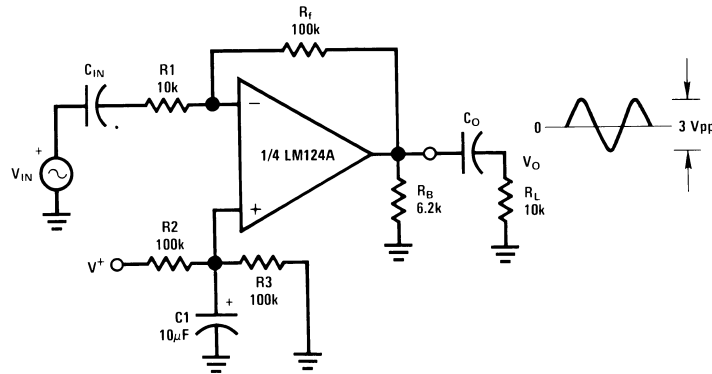

Figure 21. Photo Voltaic-Cell Amplifier

(V<sup>+</sup> = 5.0 V<sub>DC</sub>)



$$A_V = \frac{R_f}{R_1} \text{ (As shown, } A_V = 10)$$

Figure 22. AC Coupled Inverting Amplifier

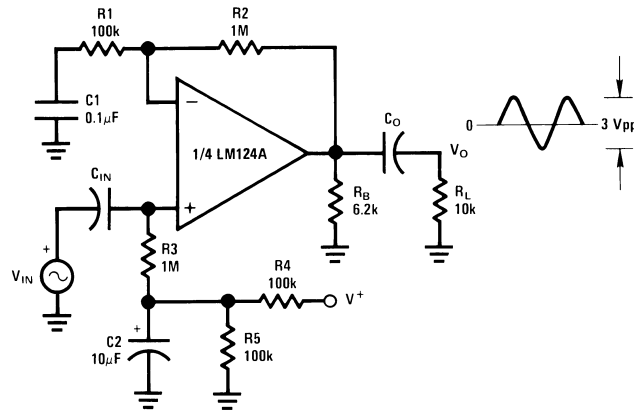

$$A_V = 1 + \frac{R_2}{R_1}$$

$A_V = 11$  (As shown)

Figure 23. AC Coupled Non-Inverting Amplifier

( $V^+ = 5.0 V_{DC}$ )

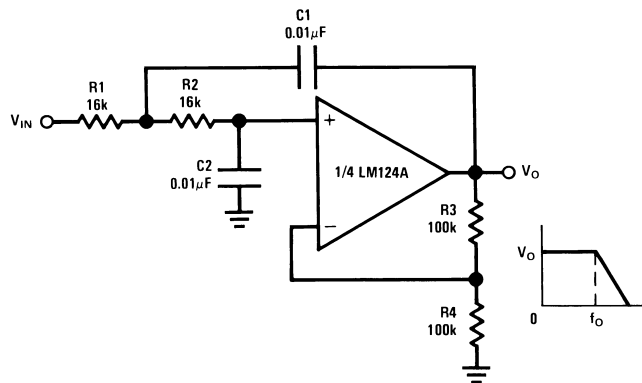

$f_o = 1 \text{ kHz}$   
 $Q = 1$   
 $A_v = 2$

Figure 24. DC Coupled Low-Pass RC Active Filter

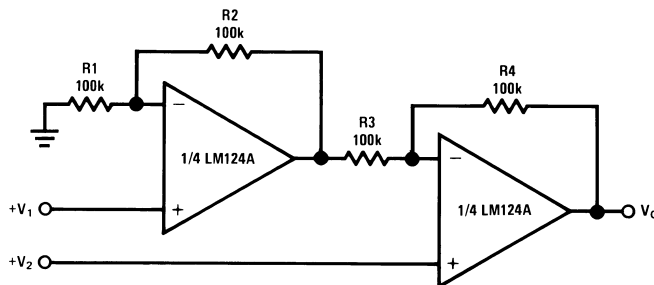

For  $\frac{R1}{R2} = \frac{R4}{R3}$  (CMRR depends on this resistor ratio match)

$$V_O = 1 + \frac{R4}{R3}(V_2 - V_1)$$

As shown:  $V_O = 2(V_2 - V_1)$

Figure 25. High Input Z, DC Differential Amplifier

( $V^+ = 5.0 V_{DC}$ )

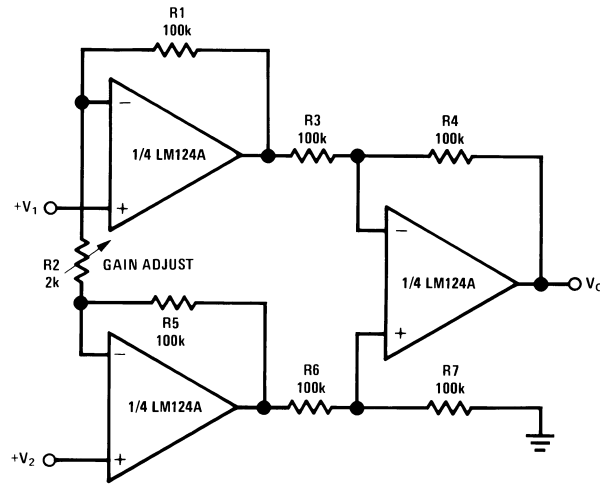

If  $R1 = R5$  &  $R3 = R4 = R6 = R7$  (CMRR depends on match)

$$V_O = 1 + \frac{2R1}{R2} (V_2 - V_1)$$

As shown  $V_O = 101 (V_2 - V_1)$

**Figure 26. High Input Z Adjustable-Gain DC Instrumentation Amplifier**

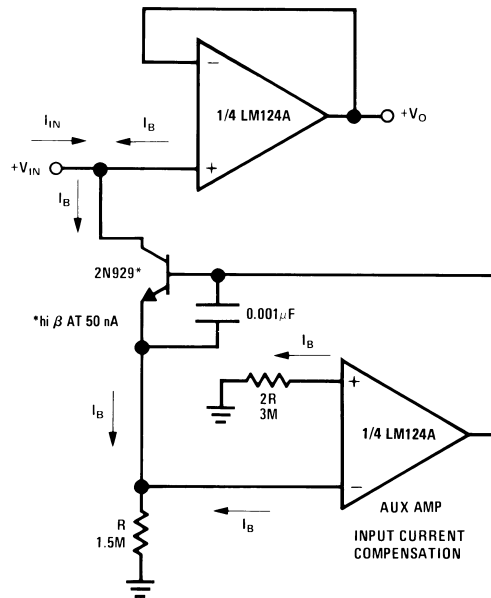

**Figure 27. Using Symmetrical Amplifiers to Reduce Input Current (General Concept)**

( $V^+ = 5.0 V_{DC}$ )

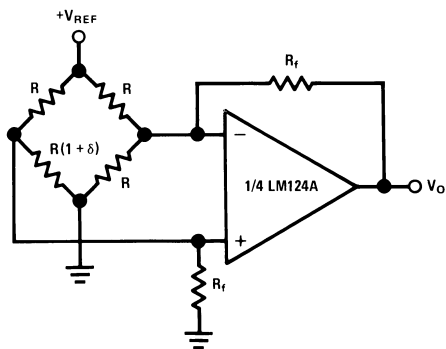

For  $\delta \ll 1$  and  $R_f \gg R$

$$V_O \approx V_{REF} \left( \frac{\delta}{2} \right) \frac{R_f}{R}$$

Figure 28. Bridge Current Amplifier

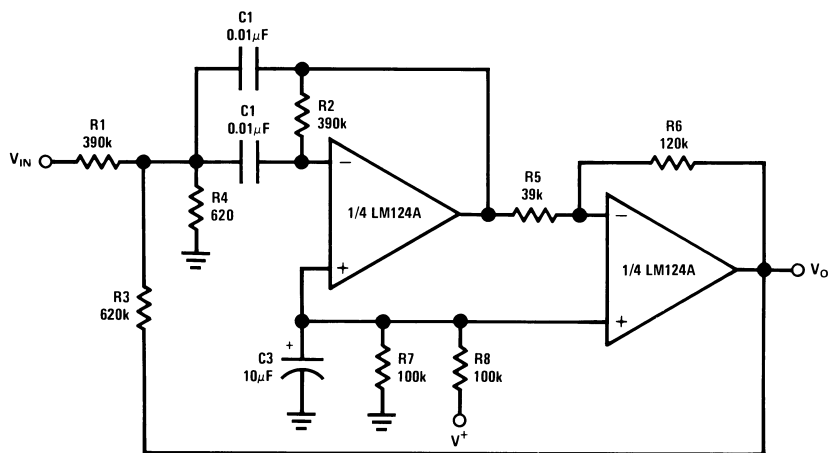

$f_0 = 1 \text{ kHz}$   
 $Q = 25$

Figure 29. Bandpass Active Filter

**PACKAGING INFORMATION**

Orderable Device	Status (1)	Package Type	Package Drawing	Pins	Package Qty	Eco Plan (2)	Lead/Ball Finish	MSL Peak Temp (3)	Op Temp (°C)	Top-Side Markings (4)	Samples
LM124AJ/PB	ACTIVE	CDIP	J	14	25	TBD	A42 SNPB	Level-1-NA-UNLIM		LM124AJ	<a href="#">Samples</a>
LM124J/PB	ACTIVE	CDIP	J	14	25	TBD	A42 SNPB	Level-1-NA-UNLIM		LM124J	<a href="#">Samples</a>
LM224J	ACTIVE	CDIP	J	14	25	TBD	A42 SNPB	Level-1-NA-UNLIM	-25 to 85	LM224J	<a href="#">Samples</a>
LM2902M	ACTIVE	SOIC	D	14	55	TBD	CU SNPB	Level-1-235C-UNLIM	-40 to 85	LM2902M	<a href="#">Samples</a>
LM2902M/NOPB	ACTIVE	SOIC	D	14	55	Green (RoHS & no Sb/Br)	CU SN	Level-1-260C-UNLIM	-40 to 85	LM2902M	<a href="#">Samples</a>
LM2902MT	ACTIVE	TSSOP	PW	14	94	TBD	CU SNPB	Level-1-260C-UNLIM	-40 to 85	LM290 2MT	<a href="#">Samples</a>
LM2902MT/NOPB	ACTIVE	TSSOP	PW	14	94	Green (RoHS & no Sb/Br)	CU SN	Level-1-260C-UNLIM	-40 to 85	LM290 2MT	<a href="#">Samples</a>
LM2902MTX	ACTIVE	TSSOP	PW	14	2500	TBD	CU SNPB	Level-1-260C-UNLIM	-40 to 85	LM290 2MT	<a href="#">Samples</a>
LM2902MTX/NOPB	ACTIVE	TSSOP	PW	14	2500	Green (RoHS & no Sb/Br)	CU SN	Level-1-260C-UNLIM	-40 to 85	LM290 2MT	<a href="#">Samples</a>
LM2902MX	ACTIVE	SOIC	D	14	2500	TBD	CU SNPB	Level-1-235C-UNLIM	-40 to 85	LM2902M	<a href="#">Samples</a>
LM2902MX/NOPB	ACTIVE	SOIC	D	14	2500	Green (RoHS & no Sb/Br)	CU SN	Level-1-260C-UNLIM	-40 to 85	LM2902M	<a href="#">Samples</a>
LM2902N/NOPB	ACTIVE	PDIP	NFF	14	25	Green (RoHS & no Sb/Br)	CU SN	Level-1-NA-UNLIM	-40 to 85	LM2902N	<a href="#">Samples</a>
LM2902N/PB	ACTIVE	PDIP	NFF	14	25	TBD	CU SNPB	Level-1-NA-UNLIM		LM2902N	<a href="#">Samples</a>
LM324AM	ACTIVE	SOIC	D	14	55	TBD	CU SNPB	Level-1-235C-UNLIM	0 to 70	LM324AM	<a href="#">Samples</a>
LM324AM/NOPB	ACTIVE	SOIC	D	14	55	Green (RoHS & no Sb/Br)	CU SN	Level-1-260C-UNLIM	0 to 70	LM324AM	<a href="#">Samples</a>
LM324AMX	ACTIVE	SOIC	D	14	2500	TBD	CU SNPB	Level-1-235C-UNLIM	0 to 70	LM324AM	<a href="#">Samples</a>
LM324AMX/NOPB	ACTIVE	SOIC	D	14	2500	Green (RoHS & no Sb/Br)	CU SN	Level-1-260C-UNLIM	0 to 70	LM324AM	<a href="#">Samples</a>
LM324AN/NOPB	ACTIVE	PDIP	NFF	14	25	Green (RoHS & no Sb/Br)	CU SN	Level-1-NA-UNLIM	0 to 70	LM324AN	<a href="#">Samples</a>

Orderable Device	Status (1)	Package Type	Package Drawing	Pins	Package Qty	Eco Plan (2)	Lead/Ball Finish	MSL Peak Temp (3)	Op Temp (°C)	Top-Side Markings (4)	Samples
LM324AN/PB	ACTIVE	PDIP	NFF	14	25	TBD	Call TI	Level-1-NA-UNLIM		LM324AN	<a href="#">Samples</a>
LM324J	ACTIVE	CDIP	J	14	25	TBD	A42 SNPB	Level-1-NA-UNLIM	0 to 70	LM324J	<a href="#">Samples</a>
LM324M	ACTIVE	SOIC	D	14	55	TBD	CU SNPB	Level-1-235C-UNLIM	0 to 70	LM324M	<a href="#">Samples</a>
LM324M/NOPB	ACTIVE	SOIC	D	14	55	Green (RoHS & no Sb/Br)	CU SN	Level-1-260C-UNLIM	0 to 70	LM324M	<a href="#">Samples</a>
LM324MT	ACTIVE	TSSOP	PW	14	94	TBD	CU SNPB	Level-1-260C-UNLIM	0 to 70	LM324 MT	<a href="#">Samples</a>
LM324MT/NOPB	ACTIVE	TSSOP	PW	14	94	Green (RoHS & no Sb/Br)	CU SN	Level-1-260C-UNLIM	0 to 70	LM324 MT	<a href="#">Samples</a>
LM324MTX	ACTIVE	TSSOP	PW	14	2500	TBD	CU SNPB	Level-1-260C-UNLIM	0 to 70	LM324 MT	<a href="#">Samples</a>
LM324MTX/NOPB	ACTIVE	TSSOP	PW	14	2500	Green (RoHS & no Sb/Br)	CU SN	Level-1-260C-UNLIM	0 to 70	LM324 MT	<a href="#">Samples</a>
LM324MX	ACTIVE	SOIC	D	14	2500	TBD	CU SNPB	Level-1-235C-UNLIM	0 to 70	LM324M	<a href="#">Samples</a>
LM324MX/NOPB	ACTIVE	SOIC	D	14	2500	Green (RoHS & no Sb/Br)	CU SN	Level-1-260C-UNLIM	0 to 70	LM324M	<a href="#">Samples</a>
LM324N/NOPB	ACTIVE	PDIP	NFF	14	25	Green (RoHS & no Sb/Br)	Call TI	Level-1-NA-UNLIM	0 to 70	LM324N	<a href="#">Samples</a>
LM324N/PB	ACTIVE	PDIP	NFF	14	25	TBD	Call TI	Level-1-NA-UNLIM		LM324N	<a href="#">Samples</a>
MLM324P	ACTIVE	PDIP	NFF	14	25	TBD	Call TI	Level-1-NA-UNLIM		LM324N	<a href="#">Samples</a>

(1) The marketing status values are defined as follows:

**ACTIVE:** Product device recommended for new designs.

**LIFEBUY:** TI has announced that the device will be discontinued, and a lifetime-buy period is in effect.

**NRND:** Not recommended for new designs. Device is in production to support existing customers, but TI does not recommend using this part in a new design.

**PREVIEW:** Device has been announced but is not in production. Samples may or may not be available.

**OBSOLETE:** TI has discontinued the production of the device.

(2) Eco Plan - The planned eco-friendly classification: Pb-Free (RoHS), Pb-Free (RoHS Exempt), or Green (RoHS & no Sb/Br) - please check <http://www.ti.com/productcontent> for the latest availability information and additional product content details.

**TBD:** The Pb-Free/Green conversion plan has not been defined.

**Pb-Free (RoHS):** TI's terms "Lead-Free" or "Pb-Free" mean semiconductor products that are compatible with the current RoHS requirements for all 6 substances, including the requirement that lead not exceed 0.1% by weight in homogeneous materials. Where designed to be soldered at high temperatures, TI Pb-Free products are suitable for use in specified lead-free processes.

---

**Pb-Free (RoHS Exempt):** This component has a RoHS exemption for either 1) lead-based flip-chip solder bumps used between the die and package, or 2) lead-based die adhesive used between the die and leadframe. The component is otherwise considered Pb-Free (RoHS compatible) as defined above.

**Green (RoHS & no Sb/Br):** TI defines "Green" to mean Pb-Free (RoHS compatible), and free of Bromine (Br) and Antimony (Sb) based flame retardants (Br or Sb do not exceed 0.1% by weight in homogeneous material)

<sup>(3)</sup> MSL, Peak Temp. -- The Moisture Sensitivity Level rating according to the JEDEC industry standard classifications, and peak solder temperature.

<sup>(4)</sup> Only one of markings shown within the brackets will appear on the physical device.

**Important Information and Disclaimer:** The information provided on this page represents TI's knowledge and belief as of the date that it is provided. TI bases its knowledge and belief on information provided by third parties, and makes no representation or warranty as to the accuracy of such information. Efforts are underway to better integrate information from third parties. TI has taken and continues to take reasonable steps to provide representative and accurate information but may not have conducted destructive testing or chemical analysis on incoming materials and chemicals. TI and TI suppliers consider certain information to be proprietary, and thus CAS numbers and other limited information may not be available for release.

In no event shall TI's liability arising out of such information exceed the total purchase price of the TI part(s) at issue in this document sold by TI to Customer on an annual basis.

**TAPE AND REEL INFORMATION**

**QUADRANT ASSIGNMENTS FOR PIN 1 ORIENTATION IN TAPE**

\*All dimensions are nominal

Device	Package Type	Package Drawing	Pins	SPQ	Reel Diameter (mm)	Reel Width W1 (mm)	A0 (mm)	B0 (mm)	K0 (mm)	P1 (mm)	W (mm)	Pin1 Quadrant
LM2902MTX	TSSOP	PW	14	2500	330.0	12.4	6.95	8.3	1.6	8.0	12.0	Q1
LM2902MTX/NOPB	TSSOP	PW	14	2500	330.0	12.4	6.95	8.3	1.6	8.0	12.0	Q1
LM2902MX	SOIC	D	14	2500	330.0	16.4	6.5	9.35	2.3	8.0	16.0	Q1
LM2902MX/NOPB	SOIC	D	14	2500	330.0	16.4	6.5	9.35	2.3	8.0	16.0	Q1
LM324AMX	SOIC	D	14	2500	330.0	16.4	6.5	9.35	2.3	8.0	16.0	Q1
LM324AMX/NOPB	SOIC	D	14	2500	330.0	16.4	6.5	9.35	2.3	8.0	16.0	Q1
LM324MTX	TSSOP	PW	14	2500	330.0	12.4	6.95	8.3	1.6	8.0	12.0	Q1
LM324MTX/NOPB	TSSOP	PW	14	2500	330.0	12.4	6.95	8.3	1.6	8.0	12.0	Q1
LM324MX	SOIC	D	14	2500	330.0	16.4	6.5	9.35	2.3	8.0	16.0	Q1
LM324MX/NOPB	SOIC	D	14	2500	330.0	16.4	6.5	9.35	2.3	8.0	16.0	Q1

**TAPE AND REEL BOX DIMENSIONS**

\*All dimensions are nominal

Device	Package Type	Package Drawing	Pins	SPQ	Length (mm)	Width (mm)	Height (mm)
LM2902MTX	TSSOP	PW	14	2500	349.0	337.0	45.0
LM2902MTX/NOPB	TSSOP	PW	14	2500	349.0	337.0	45.0
LM2902MX	SOIC	D	14	2500	349.0	337.0	45.0
LM2902MX/NOPB	SOIC	D	14	2500	349.0	337.0	45.0
LM324AMX	SOIC	D	14	2500	349.0	337.0	45.0
LM324AMX/NOPB	SOIC	D	14	2500	349.0	337.0	45.0
LM324MTX	TSSOP	PW	14	2500	349.0	337.0	45.0
LM324MTX/NOPB	TSSOP	PW	14	2500	349.0	337.0	45.0
LM324MX	SOIC	D	14	2500	349.0	337.0	45.0
LM324MX/NOPB	SOIC	D	14	2500	349.0	337.0	45.0

J (R-GDIP-T\*\*)

14 LEADS SHOWN

CERAMIC DUAL IN-LINE PACKAGE



DIM \ PINS **	14	16	18	20
A	0.300 (7,62) BSC	0.300 (7,62) BSC	0.300 (7,62) BSC	0.300 (7,62) BSC
B MAX	0.785 (19,94)	.840 (21,34)	0.960 (24,38)	1.060 (26,92)
B MIN	—	—	—	—
C MAX	0.300 (7,62)	0.300 (7,62)	0.310 (7,87)	0.300 (7,62)
C MIN	0.245 (6,22)	0.245 (6,22)	0.220 (5,59)	0.245 (6,22)



4040083/F 03/03

- NOTES:
- All linear dimensions are in inches (millimeters).
  - This drawing is subject to change without notice.
  - This package is hermetically sealed with a ceramic lid using glass frit.
  - Index point is provided on cap for terminal identification only on press ceramic glass frit seal only.
  - Falls within MIL STD 1835 GDIP1-T14, GDIP1-T16, GDIP1-T18 and GDIP1-T20.

N0014A

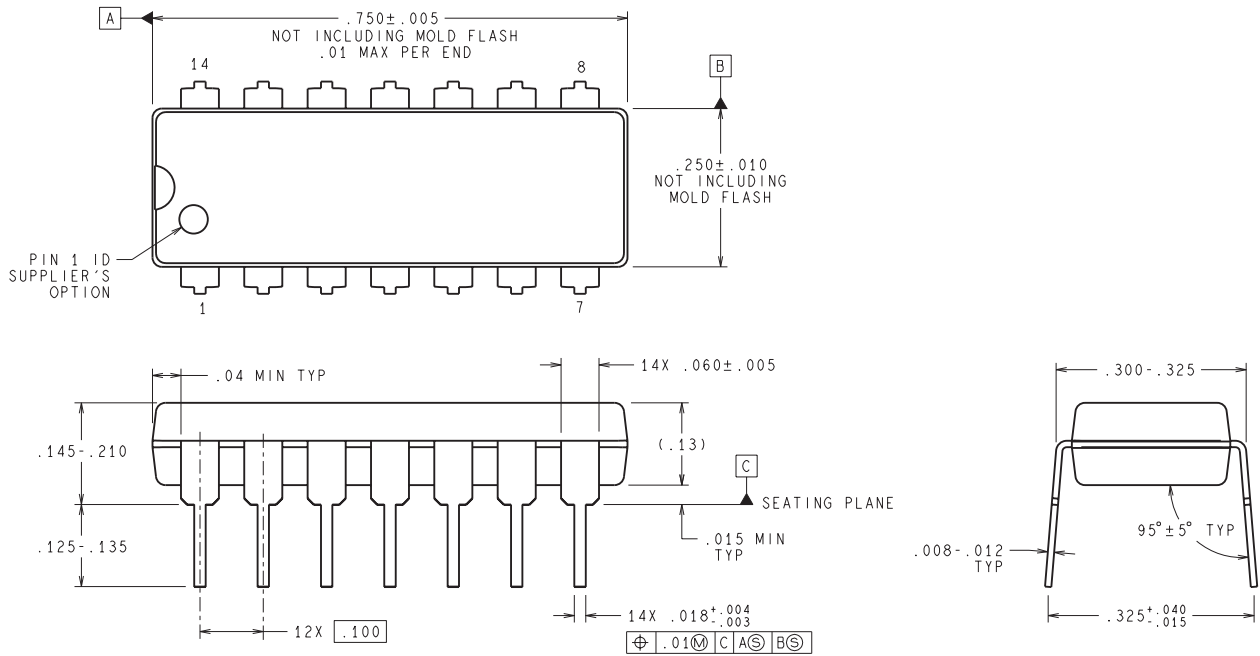

**DIMENSIONS ARE IN INCHES**  
 DIMENSIONS IN ( ) FOR REFERENCE ONLY

N14A (Rev G)



PW (R-PDSO-G14)

PLASTIC SMALL OUTLINE

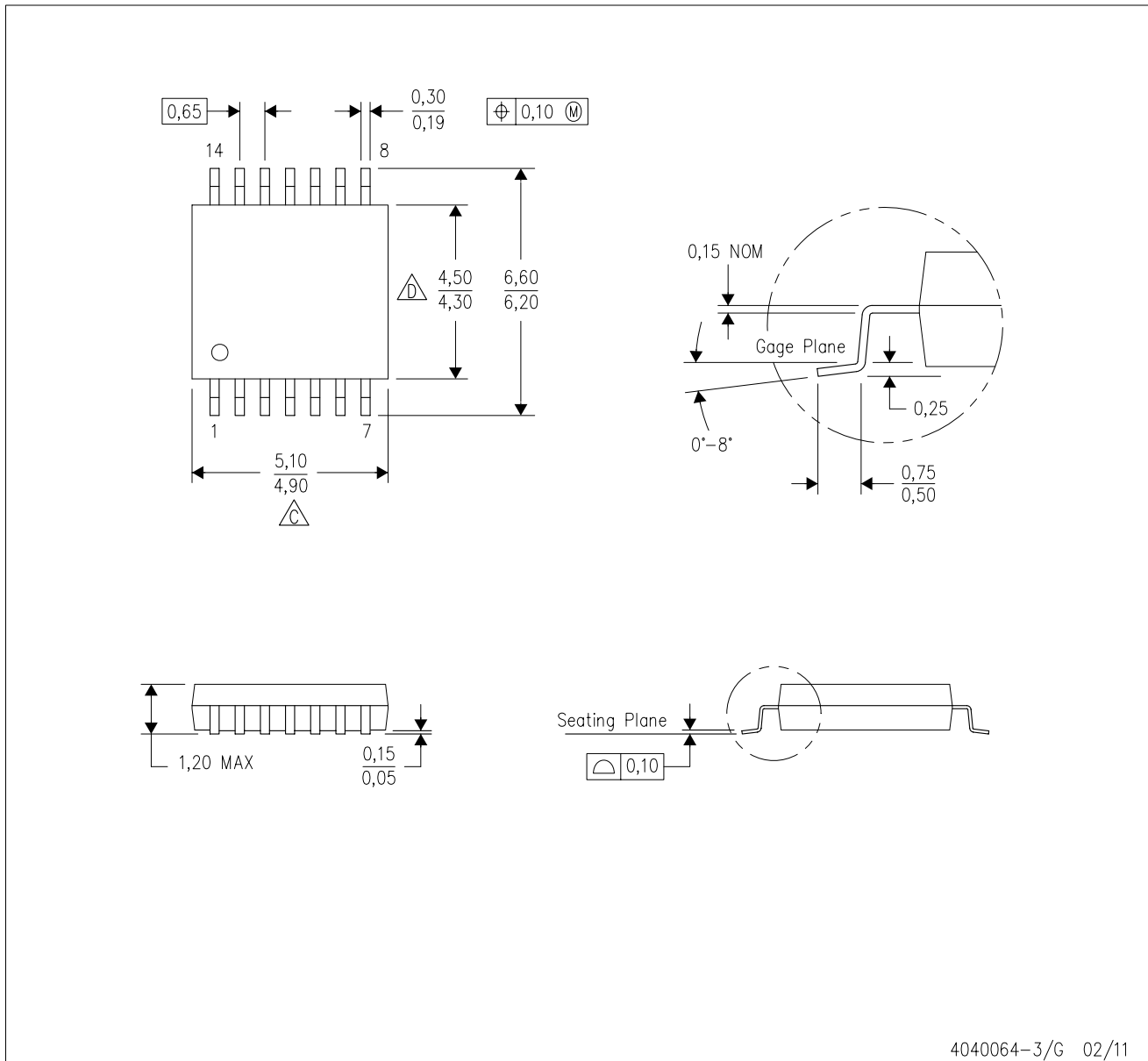

- NOTES:
- A. All linear dimensions are in millimeters. Dimensioning and tolerancing per ASME Y14.5M-1994.
  - B. This drawing is subject to change without notice.
  - C. Body length does not include mold flash, protrusions, or gate burrs. Mold flash, protrusions, or gate burrs shall not exceed 0,15 each side.
  - D. Body width does not include interlead flash. Interlead flash shall not exceed 0,25 each side.
  - E. Falls within JEDEC MO-153

## IMPORTANT NOTICE

Texas Instruments Incorporated and its subsidiaries (TI) reserve the right to make corrections, enhancements, improvements and other changes to its semiconductor products and services per JESD46, latest issue, and to discontinue any product or service per JESD48, latest issue. Buyers should obtain the latest relevant information before placing orders and should verify that such information is current and complete. All semiconductor products (also referred to herein as "components") are sold subject to TI's terms and conditions of sale supplied at the time of order acknowledgment.

TI warrants performance of its components to the specifications applicable at the time of sale, in accordance with the warranty in TI's terms and conditions of sale of semiconductor products. Testing and other quality control techniques are used to the extent TI deems necessary to support this warranty. Except where mandated by applicable law, testing of all parameters of each component is not necessarily performed.

TI assumes no liability for applications assistance or the design of Buyers' products. Buyers are responsible for their products and applications using TI components. To minimize the risks associated with Buyers' products and applications, Buyers should provide adequate design and operating safeguards.

TI does not warrant or represent that any license, either express or implied, is granted under any patent right, copyright, mask work right, or other intellectual property right relating to any combination, machine, or process in which TI components or services are used. Information published by TI regarding third-party products or services does not constitute a license to use such products or services or a warranty or endorsement thereof. Use of such information may require a license from a third party under the patents or other intellectual property of the third party, or a license from TI under the patents or other intellectual property of TI.

Reproduction of significant portions of TI information in TI data books or data sheets is permissible only if reproduction is without alteration and is accompanied by all associated warranties, conditions, limitations, and notices. TI is not responsible or liable for such altered documentation. Information of third parties may be subject to additional restrictions.

Resale of TI components or services with statements different from or beyond the parameters stated by TI for that component or service voids all express and any implied warranties for the associated TI component or service and is an unfair and deceptive business practice. TI is not responsible or liable for any such statements.

Buyer acknowledges and agrees that it is solely responsible for compliance with all legal, regulatory and safety-related requirements concerning its products, and any use of TI components in its applications, notwithstanding any applications-related information or support that may be provided by TI. Buyer represents and agrees that it has all the necessary expertise to create and implement safeguards which anticipate dangerous consequences of failures, monitor failures and their consequences, lessen the likelihood of failures that might cause harm and take appropriate remedial actions. Buyer will fully indemnify TI and its representatives against any damages arising out of the use of any TI components in safety-critical applications.

In some cases, TI components may be promoted specifically to facilitate safety-related applications. With such components, TI's goal is to help enable customers to design and create their own end-product solutions that meet applicable functional safety standards and requirements. Nonetheless, such components are subject to these terms.

No TI components are authorized for use in FDA Class III (or similar life-critical medical equipment) unless authorized officers of the parties have executed a special agreement specifically governing such use.

Only those TI components which TI has specifically designated as military grade or "enhanced plastic" are designed and intended for use in military/aerospace applications or environments. Buyer acknowledges and agrees that any military or aerospace use of TI components which have **not** been so designated is solely at the Buyer's risk, and that Buyer is solely responsible for compliance with all legal and regulatory requirements in connection with such use.

TI has specifically designated certain components as meeting ISO/TS16949 requirements, mainly for automotive use. In any case of use of non-designated products, TI will not be responsible for any failure to meet ISO/TS16949.

### Products

Audio	<a href="http://www.ti.com/audio">www.ti.com/audio</a>
Amplifiers	<a href="http://amplifier.ti.com">amplifier.ti.com</a>
Data Converters	<a href="http://dataconverter.ti.com">dataconverter.ti.com</a>
DLP® Products	<a href="http://www.dlp.com">www.dlp.com</a>
DSP	<a href="http://dsp.ti.com">dsp.ti.com</a>
Clocks and Timers	<a href="http://www.ti.com/clocks">www.ti.com/clocks</a>
Interface	<a href="http://interface.ti.com">interface.ti.com</a>
Logic	<a href="http://logic.ti.com">logic.ti.com</a>
Power Mgmt	<a href="http://power.ti.com">power.ti.com</a>
Microcontrollers	<a href="http://microcontroller.ti.com">microcontroller.ti.com</a>
RFID	<a href="http://www.ti-rfid.com">www.ti-rfid.com</a>
OMAP Applications Processors	<a href="http://www.ti.com/omap">www.ti.com/omap</a>
Wireless Connectivity	<a href="http://www.ti.com/wirelessconnectivity">www.ti.com/wirelessconnectivity</a>

### Applications

Automotive and Transportation	<a href="http://www.ti.com/automotive">www.ti.com/automotive</a>
Communications and Telecom	<a href="http://www.ti.com/communications">www.ti.com/communications</a>
Computers and Peripherals	<a href="http://www.ti.com/computers">www.ti.com/computers</a>
Consumer Electronics	<a href="http://www.ti.com/consumer-apps">www.ti.com/consumer-apps</a>
Energy and Lighting	<a href="http://www.ti.com/energy">www.ti.com/energy</a>
Industrial	<a href="http://www.ti.com/industrial">www.ti.com/industrial</a>
Medical	<a href="http://www.ti.com/medical">www.ti.com/medical</a>
Security	<a href="http://www.ti.com/security">www.ti.com/security</a>
Space, Avionics and Defense	<a href="http://www.ti.com/space-avionics-defense">www.ti.com/space-avionics-defense</a>
Video and Imaging	<a href="http://www.ti.com/video">www.ti.com/video</a>

### TI E2E Community

[e2e.ti.com](http://e2e.ti.com)

## Looking for pricing, stock, or lifecycle information?

Click below to explore more details on WIN SOURCE:

 [View LM324N/PB on WIN SOURCE](#)

 [Texas Instruments](#) Information

## Optimize Your Supply Chain with WIN SOURCE Solutions

-  Global Sourcing Solution
-  Obsolete Management
-  Cost Control Management
-  Shortage Management
-  Alternative Solution
-  Excess Inventory Management