



**THE DATASHEET OF
LH7A400N0G000B5**



FEATURES

- ARM922T™ Core:
 - 32-bit ARM9TDMI™ RISC Core (200 MHz)
 - 16KB Cache: 8KB Instruction Cache and 8KB Data Cache
 - MMU (Windows CE™ Enabled)
- 80KB On-Chip Memory
- Programmable Interrupt Controller
- External Bus Interface
 - 100 MHz
 - Asynchronous SRAM/ROM/Flash
 - Synchronous DRAM/Flash
 - PCMCIA
 - CompactFlash
- Clock and Power Management
 - 32.768 kHz and 14.7456 MHz Oscillators
 - Programmable PLL
- Low Power Modes (Typical)
 - Run (125 mA), Halt (25 mA), Standby (42 µA)
- Programmable LCD Controller
 - Up to 1,024 × 768 Resolution
 - Supports STN, Color STN, AD-TFT, HR-TFT, TFT
 - Up to 64 k-Colors and 15 Gray Shades
- DMA (10 Channels)
 - AC97
 - MMC
 - USB
- USB Device Interface (USB 1.1)
- Synchronous Serial Port (SSP)
 - Motorola SPI™
 - Texas Instruments SSI
 - National MICROWIRE™
- Three Programmable Timers
- Three UARTs
 - Classic IrDA (115 kbit/s)
- Smart Card Interface (ISO7816)
- Two DC-to-DC Converters
- MultiMediaCard™ Interface
- AC97 Codec Interface
- Smart Battery Monitor Interface
- Real Time Clock (RTC)
- Up to 60 General Purpose I/Os
- Watchdog Timer
- JTAG Debug Interface and Boundary Scan
- Operating Voltage
 - 1.8 V Core
 - 3.3 V Input/Output
- 5 V Tolerant Digital Inputs (except oscillator pins)
 - Oscillator pins P15, P16, R13, and T13 are 1.8 V ± 10%.
- Operating Temperature
 - 0°C to +70°C Commercial
 - -40°C to +85°C Industrial (With Clock Frequency Reduction)
- 256-Ball PBGA or 256-Ball CABGA Package

DESCRIPTION

The LH7A400, powered by an ARM922T, is a complete System-on-Chip with a high level of integration to satisfy a wide range of requirements and expectations.

This high degree of integration lowers overall system costs, reduces development cycle time and accelerates product introduction.

Motorola SPI is a trademark of Motorola, Inc.

National Semiconductor MICROWIRE is a trademark of National Semiconductor Corporation.

Windows CE is a trademark of Microsoft Corporation.

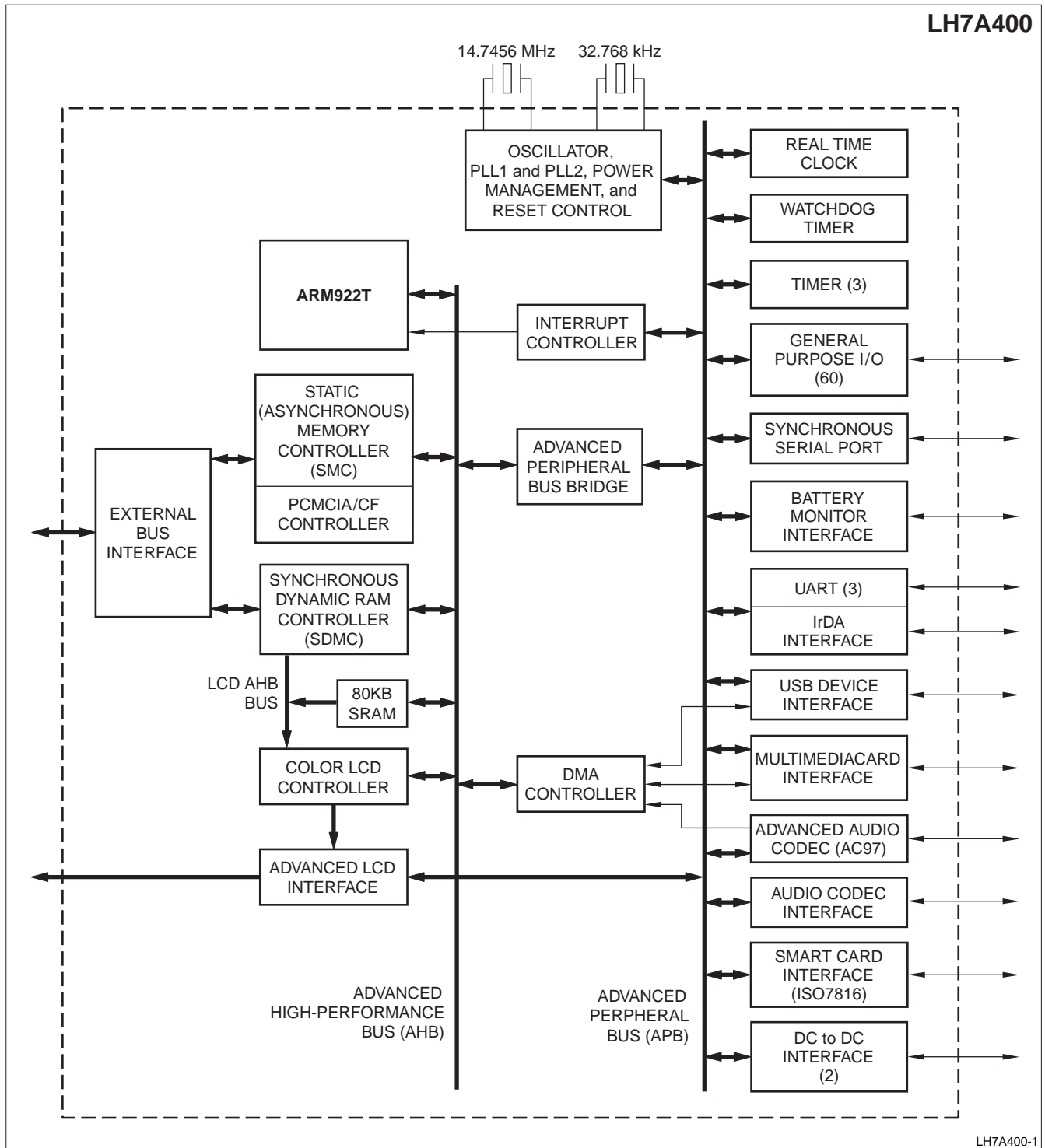

Figure 1. LH7A400 Block Diagram

Table 1. Functional Pin List

PBGA PIN	CABGA PIN	SIGNAL	DESCRIPTION	RESET STATE	STANDBY STATE	OUTPUT DRIVE
G7	C10	VDD	I/O Ring Power			
F1	F9					
K7	F11					
M1	F14					
M5	G8					
T6	H13					
R14	J9					
M14	K15					
J11	L7					
J12	N6					
F13	N8					
B14	N12					
E10	N13					
B8	P11					
H7	B8	VSS	I/O Ring Ground			
G3	C6					
K4	D5					
N5	D13					
P6	E8					
T14	F7					
R16	G13					
N16	H9					
K13	J14					
H9	K7					
C15	L8					
A11	L10					
E8	L12					
A5	M11					
F7	M14					
E1	C4	VDDC	Core Power			
J4	D7					
P3	D10					
T8	F4					
K9	F10					
L13	J4					
E15	J8					
D12	K8					
A7	L6					
H5	G7	VSSC	Core Ground			
M3	H4					
L9	H8					
T10	L4					
N15	L9					
H12	N3					
B15	N7					
C9	N10					
G6	R5					

Table 1. Functional Pin List (Cont'd)

PBGA PIN	CABGA PIN	SIGNAL	DESCRIPTION	RESET STATE	STANDBY STATE	OUTPUT DRIVE
R11	P12	VDDA	Analog Power for PLL			
N12	M10					
P12	R13	VSSA	Analog Ground for PLL			
T11	N11					
D3	E4	nPOR	Power On Reset	Input	Input	
H6	D1	nURESET	User Reset; should be pulled HIGH for normal or JTAG operation.	Input (Schmitt)	Input	
D4	E2	WAKEUP	Wake Up	Input (Schmitt)	Input	
E4	F2	nPWRFL	Power Fail Signal	Input (Schmitt)	Input	
C2	D2	nEXTPWR	External Power	Input (Schmitt)	Input	
R13	R14	XTALIN	14.7456 MHz Crystal Oscillator pins. An external clock source can be connected to XTALIN leaving XTALOUT open.	Input	Input	
T13	R15	XTALOUT		LOW	LOW	
P16	N14	XTAL32IN	32.768 kHz Real Time Clock Crystal Oscillator pins. An external clock source can be connected to XTAL32IN leaving XTAL32OUT open.	Input	Input	
P15	M13	XTAL32OUT		Output	Output	
P14	M12	CLKEN	External Oscillator Clock Enable Output	LOW	LOW	8 mA
J6	J5	PGMCLK	Programmable Clock (14.7456 MHz MAX.)	LOW	LOW	8 mA
K11	P14	nCS0	Asynchronous Memory Chip Select 0	HIGH	HIGH	12 mA
K10	P16	nCS1	Asynchronous Memory Chip Select 1	HIGH	HIGH	12 mA
P13	N15	nCS2	Asynchronous Memory Chip Select 2	HIGH	HIGH	12 mA
M12	N16	nCS3/ nMMSPICS	<ul style="list-style-type: none"> • Asynchronous Memory Chip Select 3 • MultiMediaCard SPI Mode Chip Select 	HIGH: nCS3	HIGH	12 mA

Table 1. Functional Pin List (Cont'd)

PBGA PIN	CABGA PIN	SIGNAL	DESCRIPTION	RESET STATE	STANDBY STATE	OUTPUT DRIVE
L12	L11	D0	Data Bus	LOW	LOW	12 mA
M15	L13	D1				
N13	L14	D2				
L16	K11	D3				
L15	L16	D4				
L14	K14	D5				
H11	J15	D6				
K12	J12	D7				
J15	J10	D8				
J13	H16	D9				
J10	H14	D10				
H15	H11	D11				
H13	G16	D12				
G15	G9	D13				
G11	G14	D14				
G12	G12	D15				
F15	F15	D16				
F12	E15	D17				
E14	D16	D18				
D16	F12	D19				
H10	E13	D20				
D14	D14	D21				
F10	E12	D22				
A16	B16	D23				
A14	D12	D24				
B13	A16	D25				
C13	B13	D26				
E12	B14	D27				
G10	C12	D28				
B12	A14	D29				
B11	B12	D30				
D11	A12	D31				
M16	M15	A0/nWE1	<ul style="list-style-type: none"> Asynchronous Address Bus Asynchronous Memory Write Byte Enable 1 	HIGH: nWE1	HIGH	12 mA
N14	M16	A1/nWE2	<ul style="list-style-type: none"> Asynchronous Address Bus Asynchronous Memory Write Byte Enable 2 	HIGH: nWE2	HIGH	12 mA

Table 1. Functional Pin List (Cont'd)

PBGA PIN	CABGA PIN	SIGNAL	DESCRIPTION	RESET STATE	STANDBY STATE	OUTPUT DRIVE
M13	L15	A2/SA0	<ul style="list-style-type: none"> Asynchronous Address Bus Synchronous Address Bus 	LOW	LOW	12 mA
K16	K12	A3/SA1		LOW	LOW	12 mA
K15	K13	A4/SA2		LOW	LOW	12 mA
K14	K16	A5/SA3		LOW	LOW	12 mA
J8	J13	A6/SA4		LOW	LOW	12 mA
J16	J11	A7/SA5		LOW	LOW	12 mA
J14	J16	A8/SA6		LOW	LOW	12 mA
J9	H15	A9/SA7		LOW	LOW	12 mA
H16	H10	A10/SA8		LOW	LOW	12 mA
H14	H12	A11/SA9		LOW	LOW	12 mA
G16	G15	A12/SA10		LOW	LOW	12 mA
G14	G10	A13/SA11		LOW	LOW	12 mA
G13	G11	A14/SA12		LOW	LOW	12 mA
F16	F16	A15/SA13		LOW	LOW	12 mA
F14	E16	A16/SB0	<ul style="list-style-type: none"> Asynchronous Address Bus Synchronous Device Bank Address 0 	LOW	LOW	12 mA
E16	F13	A17/SB1	<ul style="list-style-type: none"> Asynchronous Address Bus Synchronous Device Bank Address 1 	LOW	LOW	12 mA
E13	E14	A18	Asynchronous Address Bus	LOW	LOW	12 mA
F11	D15	A19				
D15	C16	A20				
C16	C15	A21				
B16	C14	A22				
A15	B15	A23				
A13	E11	A24				
G8	D8	A25/SCIO	<ul style="list-style-type: none"> Asynchronous Memory Address Bus Smart Card Interface I/O (Data) 	LOW: A25	LOW	12 mA
F8	B7	A26/SCCLK	<ul style="list-style-type: none"> Asynchronous Memory Address Bus Smart Card Interface Clock 	LOW: A26	LOW	12 mA
A8	A7	A27/SCRST	<ul style="list-style-type: none"> Asynchronous Memory Address Bus Smart Card Interface Reset 	LOW: A27	LOW	12 mA
D8	C8	nOE	Asynchronous Memory Output Enable	HIGH	HIGH	12 mA
C8	F8	nWE0	Asynchronous Memory Write Byte Enable 0	HIGH	HIGH	12 mA
D10	D9	nWE3	Asynchronous Memory Write Byte Enable 3	HIGH	HIGH	8 mA
B10	E9	CS6/SCKE1_2	<ul style="list-style-type: none"> Asynchronous Memory Chip Select 6 Synchronous Memory Clock Enable 1 OR 2 	LOW: CS6	LOW	12 mA
C10	A10	CS7/SCKE0	<ul style="list-style-type: none"> Asynchronous Memory Chip Select 7 Synchronous Memory Clock Enable 0 	LOW: CS7	LOW	12 mA
G9	A11	SCKE3	Synchronous Memory Clock Enable 3	LOW	LOW	12 mA
A10	B10	SCLK	Synchronous Memory Clock	LOW	LOW	20 mA (sink) 12 mA (source)
C14	C13	nSCS0	Synchronous Memory Chip Select 0	HIGH	HIGH	12 mA
D13	A15	nSCS1	Synchronous Memory Chip Select 1	HIGH	HIGH	12 mA
E11	D11	nSCS2	Synchronous Memory Chip Select 2	HIGH	HIGH	12 mA
A12	E10	nSCS3	Synchronous Memory Chip Select 3	HIGH	HIGH	12 mA
C12	A13	nSWE	Synchronous Memory Write Enable	HIGH	HIGH	12 mA
C11	B11	nCAS	Synchronous Memory Column Address Strobe Signal	HIGH	HIGH	12 mA

Table 1. Functional Pin List (Cont'd)

PBGA PIN	CABGA PIN	SIGNAL	DESCRIPTION	RESET STATE	STANDBY STATE	OUTPUT DRIVE
F9	C11	nRAS	Synchronous Memory Row Address Strobe Signal	HIGH	HIGH	12 mA
A9	C9	DQM0	Synchronous Memory Data Mask 0	HIGH	HIGH	12 mA
B9	A9	DQM1	Synchronous Memory Data Mask 1	HIGH	HIGH	12 mA
D9	B9	DQM2	Synchronous Memory Data Mask 2	HIGH	HIGH	12 mA
E9	A8	DQM3	Synchronous Memory Data Mask 3	HIGH	HIGH	12 mA
J5	K1	PA0/LCDVD16	<ul style="list-style-type: none"> • GPIO Port A • LCD Data bit 16. This CLCDC output signal is always LOW. 	Input: PA0	No Change	8 mA
K1	K2	PA1/LCDVD17	<ul style="list-style-type: none"> • GPIO Port A • LCD Data bit 17. This CLCDC output signal is always LOW. 	Input: PA1	No Change	8 mA
K2	K3	PA2	GPIO Port A	Input	No Change	8 mA
K3	K4	PA3				
K5	K6	PA4				
L1	K5	PA5				
L2	L1	PA6				
L3	L2	PA7				
L4	L3	PB0/UARTRX1	<ul style="list-style-type: none"> • GPIO Port B • UART1 Receive Data Input 	Input: PB0	No Change	8 mA
L5	M1	PB1/UARTTX3	<ul style="list-style-type: none"> • GPIO Port B • UART3 Transmit Data Out 	Input: PB1	LOW if UART3 is Enabled, otherwise No Change	8 mA
L7	M2	PB2/UARTRX3	<ul style="list-style-type: none"> • GPIO Port B • UART3 Receive Data In 	Input: PB2	No Change	8 mA
M2	M3	PB3/UARTCTS3	<ul style="list-style-type: none"> • GPIO Port B • UART3 Clear to Send 	Input: PB3	No Change	8 mA
M4	L5	PB4/UARTDCD3	<ul style="list-style-type: none"> • GPIO Port B • UART3 Data Carrier Detect 	Input: PB4	No Change	8 mA
N1	N1	PB5/UARTDSR3	<ul style="list-style-type: none"> • GPIO Port B • UART3 Data Set Ready 	Input: PB5	No Change	8 mA
N2	N2	PB6/SWID/SMBD	<ul style="list-style-type: none"> • GPIO Port B • Single Wire Data • Smart Battery Data 	Input: PB6	Input if SMB is Enabled, otherwise No Change	8 mA
N3	M4	PB7/SMBCLK	<ul style="list-style-type: none"> • GPIO Port B • Smart Battery Clock 	Input: PB7	Input if SMB is Enabled, otherwise No Change	8 mA
P1	P1	PC0/UARTTX1	<ul style="list-style-type: none"> • GPIO Port C • UART1 Transmit Data Output 	LOW: PC0	No Change	12 mA
P2	P2	PC1/LCDPS	<ul style="list-style-type: none"> • GPIO Port C • HR-TFT Power Save 	LOW: PC1	No Change	12 mA
R1	R1	PC2/LCDVDDEN	<ul style="list-style-type: none"> • GPIO Port C • HR-TFT Power Sequence Control 	LOW: PC2	No Change	12 mA
K6	M5	PC3/LCDREV	<ul style="list-style-type: none"> • GPIO Port C • HR-TFT Gray Scale Voltage Reverse 	LOW: PC3	No Change	12 mA
L8	P3	PC4/LCDSPS	<ul style="list-style-type: none"> • GPIO Port C • HR-TFT Reset Row Driver Counter 	LOW: PC4	No Change	12 mA
T1	N4	PC5/LCDCLS	<ul style="list-style-type: none"> • GPIO Port C • HR-TFT Row Driver Clock 	LOW: PC5	No Change	12 mA

Table 1. Functional Pin List (Cont'd)

PBGA PIN	CABGA PIN	SIGNAL	DESCRIPTION	RESET STATE	STANDBY STATE	OUTPUT DRIVE
T2	R2	PC6/LCDHRLP	<ul style="list-style-type: none"> • GPIO Port C • LCD Latch Pulse 	LOW: PC6	No Change	12 mA
R2	N5	PC7/LCDSPL	<ul style="list-style-type: none"> • GPIO Port C • LCD Start Pulse Left 	LOW: PC7	No Change	12 mA
M11	M9	PD0/LCDVD8	<ul style="list-style-type: none"> • GPIO Port D • LCD Video Data Bus 	LOW: PD0	LOW if Dual-Panel LCD is Enabled; otherwise, No Change	12 mA
L11	K10	PD1/LCDVD9		LOW: PD1		
K8	P10	PD2/LCDVD10		LOW: PD2		
N11	T11	PD3/LCDVD11		LOW: PD3		
R9	T12	PD4/LCDVD12		LOW: PD4		
T9	R11	PD5/LCDVD13		LOW: PD5		
P10	R12	PD6/LCDVD14		LOW: PD6		
R10	T13	PD7/LCDVD15		LOW: PD7		
L10	T9	PE0/LCDVD4	<ul style="list-style-type: none"> • GPIO Port E • LCD Video Data Bus 	Input: PE0	LOW if 8-bit LCD is Enabled, otherwise No Change	12 mA
N10	K9	PE1/LCDVD5		Input: PE1		
M9	T10	PE2/LCDVD6		Input: PE2		
M10	R10	PE3/LCDVD7		Input: PE3		
A6	A5	PF0/INT0	<ul style="list-style-type: none"> • GPIO Port F • External FIQ Interrupt. Interrupts can be level or edge triggered and are internally debounced. 	Input: PF0 (Schmitt)	No Change	8 mA
B6	B4	PF1/INT1	<ul style="list-style-type: none"> • GPIO Port F • External IRQ Interrupts. Interrupts can be level or edge triggered and are internally debounced. 	Input: PF1 (Schmitt)	No Change	8 mA
C6	E7	PF2/INT2		Input: PF2 (Schmitt)	No Change	8 mA
H8	B3	PF3/INT3	<ul style="list-style-type: none"> • GPIO Port F • External IRQ Interrupt. Interrupts can be level or edge triggered and are internally debounced. 	Input: PF3 (Schmitt)	No Change	8 mA
B5	C5	PF4/INT4/SCVCCEN	<ul style="list-style-type: none"> • GPIO Port F • External IRQ Interrupt. Interrupts can be level or edge triggered and are internally debounced. • Smart Card Supply Voltage Enable 	Input: PF4 (Schmitt)	LOW if SCI is Enabled; otherwise, No Change	8 mA
D6	D6	PF5/INT5/SCDETECT	<ul style="list-style-type: none"> • GPIO Port F • External IRQ Interrupt. Interrupts can be level or edge triggered and are internally debounced. • Smart Card Detection 	Input: PF5 (Schmitt)	No Change	8 mA
E6	A4	PF6/INT6/PCRDY1	<ul style="list-style-type: none"> • GPIO Port F • External IRQ Interrupt. Interrupts can be level or edge triggered and are internally debounced. • Ready for Card 1 for PC Card (PCMCIA or CompactFlash) in single or dual card mode 	Input: PF6 (Schmitt)	No Change	8 mA
C5	A3	PF7/INT7/PCRDY2	<ul style="list-style-type: none"> • GPIO Port F • External IRQ Interrupt. Interrupts can be level or edge triggered and are internally debounced. • Ready for Card 2 for PC Card (PCMCIA or CompactFlash) in single or dual card mode 	Input: PF7 (Schmitt)	No Change	8 mA
R3	M6	PG0/nPCOE	<ul style="list-style-type: none"> • GPIO Port G • Output Enable for PC Card (PCMCIA or CompactFlash) in single or dual card mode 	LOW: PG0	No Change	8 mA
T3	T1	PG1/nPCWE	<ul style="list-style-type: none"> • GPIO Port G • Write Enable for PC Card (PCMCIA or CompactFlash) in single or dual card mode 	LOW: PG1	No Change	8 mA

Table 1. Functional Pin List (Cont'd)

PBGA PIN	CABGA PIN	SIGNAL	DESCRIPTION	RESET STATE	STANDBY STATE	OUTPUT DRIVE
L6	P4	PG2/nPCIOR	<ul style="list-style-type: none"> GPIO Port G I/O Read Strobe for PC Card (PCMCIA or CompactFlash) in single or dual card mode 	LOW: PG2	No Change	8 mA
M6	R3	PG3/nPCIOW	<ul style="list-style-type: none"> GPIO Port G I/O Write Strobe for PC Card (PCMCIA or CompactFlash) in single or dual card mode 	LOW: PG3	No Change	8 mA
N6	T2	PG4/nPCREG	<ul style="list-style-type: none"> GPIO Port G Register Memory Access for PC Card (PCMCIA or CompactFlash) in single or dual card mode 	LOW: PG4	No Change	8 mA
M7	P5	PG5/nPCCE1	<ul style="list-style-type: none"> GPIO Port G Card Enable 1 for PC Card (PCMCIA or CompactFlash) in single or dual card mode. This signal and nPCCE2 are used by the PC Card for decoding low and high byte accesses. 	LOW: PG5	No Change	8 mA
M8	R4	PG6/nPCCE2	<ul style="list-style-type: none"> GPIO Port G Card Enable 2 for PC Card (PCMCIA or CompactFlash) in single or dual card mode. This signal and nPCCE1 are used by the PC Card for decoding low and high byte accesses. 	LOW: PG6	No Change	8 mA
N4	T3	PG7/PCDIR	<ul style="list-style-type: none"> GPIO Port G Direction for PC Card (PCMCIA or CompactFlash) in single or dual card mode 	LOW: PG7	No Change	8 mA
P4	P6	PH0/ PCRESET1	<ul style="list-style-type: none"> GPIO Port H Reset Card 1 for PC Card (PCMCIA or CompactFlash) in single or dual card mode 	Input: PH0	No Change	8 mA
R4	T4	PH1/CFA8/ PCRESET2	<ul style="list-style-type: none"> GPIO Port H Address Bit 8 for PC Card (CompactFlash) in single card mode Reset Card 2 for PC Card (PCMCIA or CompactFlash) in dual card mode 	Input: PH1	No Change	8 mA
T4	M7	PH2/ nPCSLOTE1	<ul style="list-style-type: none"> GPIO Port H Enable Card 1 for PC Card (PCMCIA or CompactFlash) in single or dual card mode. This signal is used for gating other control signals to the appropriate PC Card. 	Input: PH2	No Change	8 mA
N7	T5	PH3/CFA9/ PCMCIAA25/ nPCSLOTE2	<ul style="list-style-type: none"> GPIO Port H Address Bit 9 for PC Card (CompactFlash) in single card mode Address Bit 25 for PC Card (PCMCIA) in single card mode Enable Card 2 for PC Card (PCMCIA or CompactFlash) in dual card mode. This signal is used for gating other control signals to the appropriate PC Card. 	Input: PH3	No Change	8 mA
P8	R6	PH4/ nPCWAIT1	<ul style="list-style-type: none"> GPIO Port H WAIT Signal for Card 1 for PC Card (PCMCIA or CompactFlash) in single or dual card mode 	Input: PH4	No Change	8 mA
P5	R7	PH5/CFA10/ PCMCIAA24/ nPCWAIT2	<ul style="list-style-type: none"> GPIO Port H Address Bit 10 for PC Card (CompactFlash) in single card mode Address Bit 24 for PC Card (PCMCIA) in single card mode WAIT Signal for Card 2 for PC Card (PCMCIA or CompactFlash) in dual card mode 	Input: PH5	No Change	8 mA

Table 1. Functional Pin List (Cont'd)

PBGA PIN	CABGA PIN	SIGNAL	DESCRIPTION	RESET STATE	STANDBY STATE	OUTPUT DRIVE
R5	P7	PH6/ AC97RESET	<ul style="list-style-type: none"> • GPIO Port H • Audio Codec (AC97) Reset 	Input: PH6	No Change	8 mA
T5	T6	PH7/nPC- STATRE	<ul style="list-style-type: none"> • GPIO Port H • Status Read Enable for PC Card (PCMCIA or CompactFlash) in single or dual card mode 	Input: PH7	No Change	8 mA
R6	T7	LCDFP	LCD Frame Synchronization pulse	LOW	LOW	12 mA
R8	R9	LCDLP	LCD Line Synchronization pulse	LOW	LOW	12 mA
P9	P9	LCDENAB/ LCDM	<ul style="list-style-type: none"> • LCD TFT Data Enable • LCD STN AC Bias 	LOW: LCDENAB	LOW	12 mA
N9	N9	LCDDCLK	LCD Data Clock	LOW	LOW	12 mA
P7	M8	LCDVD0	LCD Video Data Bus	LOW	LOW	12 mA
R7	P8	LCDVD1				
T7	R8	LCDVD2				
N8	T8	LCDVD3				
T15	T16	USBDP	USB Data Positive (Differential Pair)	Input	Input	75 mA (NOM.)
T16	R16	USBDN	USB Data Negative (Differential Pair)	Input	Input	75 mA (NOM.)
E7	C7	nPWME0	DC-DC Converter Pulse Width Modulator 0 Enable	Input	Input	
D7	A6	nPWME1	DC-DC Converter Pulse Width Modulator 1 Enable	Input	Input	
C7	B6	PWM0	DC-DC Converter Pulse Width Modulator 0 Output during normal operation and Polarity Selection input at reset	Input	Input	8 mA
B7	B5	PWM1	DC-DC Converter Pulse Width Modulator 1 Output during normal operation and Polarity Selection input at reset	Input	Input	8 mA
C4	A2	ACBITCLK	<ul style="list-style-type: none"> • Audio Codec (AC97) Clock • Audio Codec (ACI) Clock 	Input	Input	
D5	A1	ACOUT	<ul style="list-style-type: none"> • Audio Codec (AC97) Output • Audio Codec (ACI) Output 	LOW	LOW	8 mA
B4	B2	ACSYNC	<ul style="list-style-type: none"> • Audio Codec (AC97) Synchronization • Audio Codec (ACI) Synchronization 	LOW	LOW	8 mA
A4	E6	ACIN	<ul style="list-style-type: none"> • Audio Codec (AC97) Input • Audio Codec (ACI) Input 	Input	Input	
A3	C3	MMCCLK/ MMSPICLK	<ul style="list-style-type: none"> • MultiMediaCard Clock (20 MHz MAX.) • MultiMediaCard SPI Mode Clock 	LOW: MMCCLK	LOW	8 mA
B3	B1	MMCCMD/ MMSPIDIN	<ul style="list-style-type: none"> • MultiMediaCard Command • MultiMediaCard SPI Mode Data Input 	Input: MMCCMD	Input	8 mA
A2	D4	MMCDATA/ MMSPIDOUT	<ul style="list-style-type: none"> • MultiMediaCard Data • MultiMediaCard SPI Mode Data Output 	Input: MMCDATA	Input	8 mA
E2	E1	UARTCTS2	UART2 Clear to Send Signal. This pin is an output for JTAG boundary scan only.	Input	Input	
E3	F3	UARTDCD2	UART2 Data Carrier Detect Signal. This pin is output for JTAG boundary scan only.	Input	Input	
E5	G4	UARTDSR2	UART2 Data Set Ready Signal	Input	Input	
F2	G5	UARTIRTX1	IrDA Transmit	LOW	LOW	8 mA
F3	G6	UARTIRRX1	IrDA Receive. This pin is an output for JTAG boundary scan only.	Input	Input	
F4	F1	UARTTX2	UART2 Transmit Data Output	HIGH	HIGH	8 mA

Table 1. Functional Pin List (Cont'd)

PBGA PIN	CABGA PIN	SIGNAL	DESCRIPTION	RESET STATE	STANDBY STATE	OUTPUT DRIVE
J7	G3	UARTRX2	UART2 Receive Data Input. This pin is an output for JTAG boundary scan only.	Input	Input	
H4	J3	SSPCLK	Synchronous Serial Port Clock	LOW	LOW	8 mA
J1	J6	SSPRX	Synchronous Serial Port Receive	Input	Input	
J2	J7	SSPTX	Synchronous Serial Port Transmit	LOW	LOW	8 mA
J3	J2	SSPFRM/ nSSPFRM	Synchronous Serial Port Frame Sync	HIGH:	Output	8 mA
F6	G2	COL0	Keyboard Interface	HIGH	HIGH	8 mA
F5	G1	COL1				
G1	H3	COL2				
G2	H5	COL3				
G4	H6	COL4				
G5	H7	COL5				
H1	H2	COL6				
H2	H1	COL7				
H3	J1	TBUZ	Timer Buzzer (254 kHz MAX.)	LOW	LOW	8 mA
C3	F5	MEDCHG	Boot Device Media Change. Used with WIDTH0 and WIDTH1 to specify boot memory device.	Input (Schmitt)	Input	
P11	T14	WIDTH0	External Memory Width Pins. Also, used with MEDCHG to specify the boot memory device size. These pins have weak internal pull-up resistors.	Input (Schmitt) with pull-up	Input with pull-up	
R12	T15	WIDTH1				
D1	E3	BATOK	Battery OK	Input (Schmitt)	Input	
D2	F6	nBATCHG	Battery Change	Input (Schmitt)	Input	
A1	E5	TDI	JTAG Data In. This signal is internally pulled-up to VDD.	Input with Pull-up	Input with Pull-up	
B1	C2	TCK	JTAG Clock. This signal should be externally pulled-up to VDD.	Input	Input	
B2	D3	TDO	JTAG Data Out. This signal should be externally pulled up to VDD with a 33 kΩ resistor.	Input	No Change	4 mA
C1	C1	TMS	JTAG Test Mode select. This signal is internally pulled-up to VDD.	Input with Pull-up	Input with Pull-up	
T12	P15	nTEST0	Test Pin 0. Internally pulled up to VDD. For Normal mode, leave open. For JTAG mode, tie to GND. See Table 2.	Input with Pull-up	Input with Pull-up	
R15	P13	nTEST1	Test Pin 1. internally pulled up to VDD. For Normal and JTAG mode, leave open. See Table 2.	Input with Pull-up	Input with Pull-up	

NOTES: *Signals beginning with 'n' are Active LOW.

Table 2. nTest Pin Function

MODE	nTEST0	nTEST1	nURESET
JTAG	0	1	1
Normal	1	1	x

Table 3. LCD Data Multiplexing

PBGA PIN	CABGA PIN	LCD DATA SIGNAL	STN						TFT	AD-TFT/ HR-TFT	
			MONO 4-BIT		MONO 8-BIT		COLOR				
			SINGLE PANEL	DUAL PANEL	SINGLE PANEL	DUAL PANEL	SINGLE PANEL	DUAL PANEL			
K1	K2	LCDVD17									LOW
J5	K1	LCDVD16									LOW
R10	T13	LCDVD15				MLSTN7		CLSTN7	Intensity	Intensity	
P10	R12	LCDVD14				MLSTN6		CLSTN6	BLUE4	BLUE4	
T9	R11	LCDVD13				MLSTN5		CLSTN5	BLUE3	BLUE3	
R9	T12	LCDVD12				MLSTN4		CLSTN4	BLUE2	BLUE2	
N11	T11	LCDVD11				MLSTN3		CLSTN3	BLUE1	BLUE1	
K8	P10	LCDVD10				MLSTN2		CLSTN2	BLUE0	BLUE0	
L11	K10	LCDVD9				MLSTN1		CLSTN1	GREEN4	GREEN4	
M11	M9	LCDVD8				MLSTN0		CLSTN0	GREEN3	GREEN3	
M10	R10	LCDVD7		MLSTN3	MUSTN7	MUSTN7	CUSTN7	CUSTN7	GREEN2	GREEN2	
M9	T10	LCDVD6		MLSTN2	MUSTN6	MUSTN6	CUSTN6	CUSTN6	GREEN1	GREEN1	
N10	K9	LCDVD5		MLSTN1	MUSTN5	MUSTN5	CUSTN5	CUSTN5	GREEN0	GREEN0	
L10	T9	LCDVD4		MLSTN0	MUSTN4	MUSTN4	CUSTN4	CUSTN4	RED4	RED4	
N8	T8	LCDVD3	MUSTN3	MUSTN3	MUSTN3	MUSTN3	CUSTN3	CUSTN3	RED3	RED3	
T7	R8	LCDVD2	MUSTN2	MUSTN2	MUSTN2	MUSTN2	CUSTN2	CUSTN2	RED2	RED2	
R7	P8	LCDVD1	MUSTN1	MUSTN1	MUSTN1	MUSTN1	CUSTN1	CUSTN1	RED1	RED1	
P7	M8	LCDVD0	MUSTN0	MUSTN0	MUSTN0	MUSTN0	CUSTN0	CUSTN0	RED0	RED0	

NOTES:

1. The Intensity bit is identically generated for all three colors.
2. MU = Monochrome Upper
3. CU = Color Upper
4. CL = Color Lower

Table 4. 256-Ball PBGA Package Numerical Pin List

BGA PIN	SIGNAL	RESET STATE	STANDBY STATE
A1	TDI	Input with Pull-up	Input with Pull-up
A2	MMCDATA/MMSPIDOUT	Input: MMSPIDOUT	LOW
A3	MMCCLK/MMSPICK	LOW: MMSPICK	LOW
A4	ACIN	Input	Input
A5	VSS		
A6	PF0/INT0	Input: PF0	No Change
A7	VDDC		
A8	A27/SCRST	LOW: A27	LOW
A9	DQM0	HIGH	LOW
A10	SCLK	LOW	LOW
A11	VSS		
A12	nSCS3	HIGH	HIGH
A13	A24	LOW	LOW
A14	D24	LOW	LOW
A15	A23	LOW	LOW
A16	D23	LOW	LOW
B1	TCK	Input	Input
B2	TDO	Input	No Change
B3	MMCCMD/MMSPIDIN	Input: MMSPIDIN	LOW
B4	ACSYNC	LOW	LOW
B5	PF4/INT4/SCVCCEN	Input: PF4	LOW if SCI is Enabled; otherwise, No Change
B6	PF1/INT1	Input: PF1	No Change
B7	PWM1	Input	Input
B8	VDD		
B9	DQM1	HIGH	LOW
B10	CS6/SCKE1_2	LOW: CS6	LOW
B11	D30	LOW	LOW
B12	D29	LOW	LOW
B13	D25	LOW	LOW
B14	VDD		
B15	VSSC		
B16	A22	LOW	LOW
C1	TMS	Input with Pull-up	Input with Pull-up
C2	nEXTPWR	Input	Input
C3	MEDCHG	Input	Input
C4	ACBITCLK	Input	Input
C5	PF7/INT7/PCRDY2	Input: PF7	No Change
C6	PF2/INT2	PF2/INT2	No Change
C7	PWM0	Input	Input
C8	nWE0	HIGH	HIGH
C9	VSSC		
C10	CS7/SCKE0	LOW: CS7	LOW
C11	nCAS	HIGH	HIGH
C12	nSWE	HIGH	HIGH
C13	D26	LOW	LOW

Table 4. 256-Ball PBGA Package Numerical Pin List (Cont'd)

BGA PIN	SIGNAL	RESET STATE	STANDBY STATE
C14	nSCS0	HIGH	HIGH
C15	VSS		
C16	A21	LOW	LOW
D1	BATOK	Input	Input
D2	nBATCHG	Input	Input
D3	nPOR	Input	Input
D4	WAKEUP	Input	Input
D5	ACOUT	LOW	LOW
D6	PF5/INT5/SCDETECT	Input: PF5	No Change
D7	nPWME1	Input	Input
D8	nOE	HIGH	HIGH
D9	DQM2	HIGH	LOW
D10	nWE3	HIGH	HIGH
D11	D31	LOW	LOW
D12	VDDC		
D13	nSCS1	HIGH	HIGH
D14	D21	LOW	LOW
D15	A20	LOW	LOW
D16	D19	LOW	LOW
E1	VDDC		
E2	UARTCTS2	Input	Input
E3	UARTDCD2	Input	Input
E4	nPWRFL	Input	Input
E5	UARTDSR2	Input	Input
E6	PF6/INT6/PCRDY1	Input: PF6	No Change
E7	nPWME0	Input	Input
E8	VSS		
E9	DQM3	HIGH	LOW
E10	VDD		
E11	nSCS2	HIGH	HIGH
E12	D27	LOW	LOW
E13	A18	LOW	LOW
E14	D18	LOW	LOW
E15	VDDC		
E16	A17/SB1	LOW: SBANK1	LOW
F1	VDD		
F2	UARTIRTX1	LOW	LOW
F3	UARTIRRX1	Input	Input
F4	UARTTX2	HIGH	HIGH
F5	COL1	HIGH	HIGH
F6	COL0	HIGH	HIGH
F7	VSS		
F8	A26/SCCLK	LOW: A26	LOW
F9	nRAS	HIGH	HIGH
F10	D22	LOW	LOW

Table 4. 256-Ball PBGA Package Numerical Pin List (Cont'd)

BGA PIN	SIGNAL	RESET STATE	STANDBY STATE
F11	A19	LOW	LOW
F12	D17	LOW	LOW
F13	VDD		
F14	A16/SB0	LOW: SBANK0	LOW
F15	D16	LOW	LOW
F16	A15/SA13	LOW: SA13	LOW
G1	COL2	HIGH	HIGH
G2	COL3	HIGH	HIGH
G3	VSS		
G4	COL4	HIGH	HIGH
G5	COL5	HIGH	HIGH
G6	VSSC		
G7	VDD		
G8	A25/SCIO	LOW: A25	LOW
G9	SCKE3	LOW	LOW
G10	D28	LOW	LOW
G11	D14	LOW	LOW
G12	D15	LOW	LOW
G13	A14/SA12	LOW: SA12	LOW
G14	A13/SA11	LOW: SA11	LOW
G15	D13	LOW	LOW
G16	A12/SA10	LOW: SA10	LOW
H1	COL6	HIGH	HIGH
H2	COL7	HIGH	HIGH
H3	TBUZ	LOW	LOW
H4	SSPCLK	LOW	LOW
H5	VSSC		
H6	nURESET	Input	Input
H7	VSS		
H8	PF3/INT3	Input: PF3	No Change
H9	VSS		
H10	D20	LOW	LOW
H11	D6	LOW	LOW
H12	VSSC		
H13	D12	LOW	LOW
H14	A11/SA9	LOW: SA9	LOW
H15	D11	LOW	LOW
H16	A10/SA8	LOW: SA8	LOW
J1	SSPRX	Input	Input
J2	SSPTX	LOW	LOW
J3	SSPFRM/nSSPFRM	Input: nSSPFRM	Input
J4	VDDC		
J5	PA0/LCDVD16	Input: PA0	No Change
J6	PGMCLK	LOW	LOW
J7	UARTRX2	Input	Input

Table 4. 256-Ball PBGA Package Numerical Pin List (Cont'd)

BGA PIN	SIGNAL	RESET STATE	STANDBY STATE
J8	A6/SA4	LOW: SA4	LOW
J9	A9/SA7	LOW: SA7	LOW
J10	D10	LOW	LOW
J11	VDD		
J12	VDD		
J13	D9	LOW	LOW
J14	A8/SA6	LOW: SA6	LOW
J15	D8	LOW	LOW
J16	A7/SA5	LOW: SA5	LOW
K1	PA1/LCDVD17	Input: PA1	No Change
K2	PA2	Input	No Change
K3	PA3	Input	No Change
K4	VSS		
K5	PA4	Input	No Change
K6	PC3/LCDREV	LOW: PC3	No Change
K7	VDD		
K8	PD2/LCDVD10	LOW: PD2	LOW if Dual-Panel LCD is Enabled; otherwise, No Change
K9	VDDC		
K10	nCS1	HIGH	HIGH
K11	nCS0	HIGH	HIGH
K12	D7	LOW	LOW
K13	VSS		
K14	A5/SA3	LOW: SA3	LOW
K15	A4/SA2	LOW: SA2	LOW
K16	A3/SA1	LOW: SA1	LOW
L1	PA5	Input	No Change
L2	PA6	Input	No Change
L3	PA7	Input	No Change
L4	PB0/UARTX1	Input: PB0	No Change
L5	PB1/UARTX3	Input: PB1	LOW if UART3 is Enabled, otherwise No Change
L6	PG2/nPCIOR	LOW: PG2	No Change
L7	PB2/UARTX3	Input: PB2	No Change
L8	PC4/LCDSPS	LOW: PC4	No Change
L9	VSSC		
L10	PE0/LCDVD4	Input: PE0	LOW if 8-bit LCD is Enabled, otherwise No Change
L11	PD1/LCDVD9	LOW: PD1	LOW if Dual-Panel LCD is Enabled; otherwise, No Change
L12	D0	LOW	LOW
L13	VDDC		
L14	D5	LOW	LOW
L15	D4	LOW	LOW
L16	D3	LOW	LOW
M1	VDD		
M2	PB3/UARTCTS3	Input: PB3	No Change
M3	VSSC		

Table 4. 256-Ball PBGA Package Numerical Pin List (Cont'd)

BGA PIN	SIGNAL	RESET STATE	STANDBY STATE
M4	PB4/UARTDCD3	Input: PB4	No Change
M5	VDD		
M6	PG3/nPCIOW	LOW: PG3	No Change
M7	PG5/nPCCE1	LOW: PG5	No Change
M8	PG6/nPCCE2	LOW: PG6	No Change
M9	PE2/LCDVD6	Input: PE2	LOW if 8-bit LCD is Enabled; otherwise No Change
M10	PE3/LCDVD7	Input: PE3	LOW if 8-bit LCD is Enabled; otherwise No Change
M11	PD0/LCDVD8	LOW: PD0	LOW if Dual-Panel LCD is Enabled; otherwise, No Change
M12	nCS3/nMMSPICS	HIGH: nCS3	HIGH
M13	A2/SA0	LOW: SA0	LOW
M14	VDD		
M15	D1	LOW	LOW
M16	A0/nWE1	HIGH: nWE1	HIGH
N1	PB5/UARTDSR3	Input: PB5	No Change
N2	PB6/SWID/SMBD	Input: PB6	Input if SMB is Enabled; otherwise No Change
N3	PB7/SMBCLK	Input: PB7	Input if SMB is Enabled; otherwise No Change
N4	PG7/PCDIR	LOW: PG7	No Change
N5	VSS		
N6	PG4/nPCREG	LOW: PG4	No Change
N7	PH3/CFA9/PCMCIAA25/nPCSLOTE2	Input: PH3	No Change
N8	LCDVD3	LOW	LOW
N9	LCDDCLK	LOW	LOW
N10	PE1/LCDVD5	Input: PE1	LOW if 8-bit LCD is Enabled; otherwise No Change
N11	PD3/LCDVD11	LOW: PD3	LOW if Dual-Panel LCD is Enabled; otherwise, No Change
N12	VDDA		
N13	D2	LOW	LOW
N14	A1/nWE2	HIGH: nWE2	HIGH
N15	VSSC		
N16	VSS		
P1	PC0/UARTTX1	LOW: PC0	No Change
P2	PC1/LCDPS	LOW: PC1	No Change
P3	VDDC		
P4	PH0/PCRESET1	Input: PH0	No Change
P5	PH5/CFA10/PCMCIAA24/nPCWAIT2	Input: PH5	No Change
P6	VSS		
P7	LCDVD0	LOW	LOW
P8	PH4/nPCWAIT1	Input: PH4	No Change
P9	LCDENAB/LCDM	LOW: LCDENAB	LOW
P10	PD6/LCDVD14	LOW: PD6	LOW if Dual-Panel LCD is Enabled; otherwise, No Change
P11	WIDTH0	Input	Input
P12	VSSA		
P13	nCS2	HIGH	HIGH
P14	CLKEN	LOW	LOW

Table 4. 256-Ball PBGA Package Numerical Pin List (Cont'd)

BGA PIN	SIGNAL	RESET STATE	STANDBY STATE
P15	XTAL32OUT	Output	Output
P16	XTAL32IN	Input	Input
R1	PC2/LCDVDDEN	LOW: PC2	No Change
R2	PC7/LCDSPL	LOW: PC7	No Change
R3	PG0/nPCOE	LOW: PG0	No Change
R4	PH1/CFA8/PCRESET2	Input: PH1	No Change
R5	PH6/nAC97/RESET	Input: PH6	No Change
R6	LCDFP	LOW	LOW
R7	LCDVD1	LOW	LOW
R8	LCDLP	LOW	LOW
R9	PD4/LCDVD12	LOW: PD4	LOW if Dual-Panel LCD is Enabled; otherwise, No Change
R10	PD7/LCDVD15	LOW: PD7	LOW if Dual-Panel LCD is Enabled; otherwise, No Change
R11	VDDA		
R12	WIDTH1	Input	Input
R13	XTALIN	Input	Input
R14	VDD		
R15	nTEST1	Input with Pull-up	Input with Pull-up
R16	VSS		
T1	PC5/LCDCLS	LOW: PC5	No Change
T2	PC6/LCDHRLP	LOW: PC6	No Change
T3	PG1/nPCWE	LOW: PG1	No Change
T4	PH2/nPCSLOTE1	Input: PH2	No Change
T5	PH7/nPCSTATRE	Input: PH7	No Change
T6	VDD		
T7	LCDVD2	LOW	LOW
T8	VDDC		
T9	PD5/LCDVD13	LOW: PD5	LOW if Dual-Panel LCD is Enabled; otherwise, No Change
T10	VSSC		
T11	VSSA		
T12	nTEST0	Input with Pull-up	Input with Pull-up
T13	XTALOUT	LOW	LOW
T14	VSS		
T15	USBDP	HIGH	HIGH
T16	USBDN	LOW	LOW

NOTE: 'No Change' means the pin remains as it was programmed prior to entering the Standby state.

Table 5. 256-Ball CABGA Package Numerical Pin List

CABGA PIN	SIGNAL	RESET STATE	STANDBY STATE
A1	ACOUT	LOW	LOW
A2	ACBITCLK	Input	Input
A3	PF7/INT7/PCRDY2	Input: PF7 (Schmitt)	No Change
A4	PF6/INT6/PCRDY1	Input: PF6 (Schmitt)	No Change
A5	PF0/INT0	Input: PF0 (Schmitt)	No Change
A6	nPWME1	Input	Input
A7	A27/SCRST	LOW: A27	LOW
A8	DQM3	HIGH	HIGH
A9	DQM1	HIGH	HIGH
A10	CS7/SCKE0	LOW: CS7	LOW
A11	SCKE3	LOW	LOW
A12	D31	LOW	LOW
A13	nSWE	HIGH	HIGH
A14	D29	LOW	LOW
A15	nSCS1	HIGH	HIGH
A16	D25	LOW	LOW
B1	MMCCMD/MMSPIDIN	Input: MMCCMD	Input
B2	ACSYNC	LOW	LOW
B3	PF3/INT3	Input: PF3 (Schmitt)	No Change
B4	PF1/INT1	Input: PF1 (Schmitt)	No Change
B5	PWM1	Input	Input
B6	PWM0	Input	Input
B7	A26/SCCLK	LOW: A26	LOW
B8	VSS		
B9	DQM2	HIGH	HIGH
B10	SCLK	LOW	LOW
B11	nCAS	HIGH	HIGH
B12	D30	LOW	LOW
B13	D26	LOW	LOW
B14	D27	LOW	LOW
B15	A23	LOW	LOW
B16	D23	LOW	LOW
C1	TMS	Input with Pull-up	Input with Pull-up
C2	TCK	Input	Input
C3	MMCCLK/MMSPICLK	LOW: MMCCLK	LOW
C4	VDDC		
C5	PF4/INT4/SCVCCEN	Input: PF4 (Schmitt)	LOW if SCI is Enabled; otherwise, No Change
C6	VSS		
C7	nPWME0	Input	Input
C8	nOE	HIGH	HIGH
C9	DQM0	HIGH	HIGH
C10	VDD		
C11	nRAS	HIGH	HIGH

Table 5. 256-Ball CABGA Package Numerical Pin List

CABGA PIN	SIGNAL	RESET STATE	STANDBY STATE
C12	D28	LOW	LOW
C13	nSCS0	HIGH	HIGH
C14	A22	LOW	LOW
C15	A21	LOW	LOW
C16	A20	LOW	LOW
D1	nURESET	Input (Schmitt)	Input
D2	nEXTPWR	Input (Schmitt)	Input
D3	TDO	Input	No Change
D4	MMCDATA/MMSPIDOUT	Input: MMCDATA	Input
D5	VSS		
D6	PF5/INT5/SCDETECT	Input: PF5 (Schmitt)	No Change
D7	VDDC		
D8	A25/SCIO	LOW: A25	LOW
D9	nWE3	HIGH	HIGH
D10	VDDC		
D11	nSCS2	HIGH	HIGH
D12	D24	LOW	LOW
D13	VSS		
D14	D21	LOW	LOW
D15	A19	LOW	LOW
D16	D18	LOW	LOW
E1	UARTCTS2	Input	Input
E2	WAKEUP	Input (Schmitt)	Input
E3	BATOK	Input (Schmitt)	Input
E4	nPOR	Input	Input
E5	TDI	Input with Pull-up	Input with Pull-up
E6	ACIN	Input	Input
E7	PF2/INT2	Input: PF2 (Schmitt)	No Change
E8	VSS		
E9	CS6/SCKE1_2	LOW: CS6	LOW
E10	nSCS3	HIGH	HIGH
E11	A24	LOW	LOW
E12	D22	LOW	LOW
E13	D20	LOW	LOW
E14	A18	LOW	LOW
E15	D17	LOW	LOW
E16	A16/SB0	LOW	LOW
F1	UARTTX2	HIGH	HIGH
F2	nPWRFL	Input (Schmitt)	Input
F3	UARTDCD2	Input	Input
F4	VDDC		
F5	MEDCHG	Input (Schmitt)	Input
F6	nBATCHG	Input (Schmitt)	Input

Table 5. 256-Ball CABGA Package Numerical Pin List

CABGA PIN	SIGNAL	RESET STATE	STANDBY STATE
F7	VSS		
F8	nWE0	HIGH	HIGH
F9	VDD		
F10	VDDC		
F11	VDD		
F12	D19	LOW	LOW
F13	A17/SB1	LOW	LOW
F14	VDD		
F15	D16	LOW	LOW
F16	A15/SA13	LOW	LOW
G1	COL1	HIGH	HIGH
G2	COL0	HIGH	HIGH
G3	UARTRX2	Input	Input
G4	UARTDSR2	Input	Input
G5	UARTIRTX1	LOW	LOW
G6	UARTIRRX1	Input	Input
G7	VSSC		
G8	VDD		
G9	D13	LOW	LOW
G10	A13/SA11	LOW	LOW
G11	A14/SA12	LOW	LOW
G12	D15	LOW	LOW
G13	VSS		
G14	D14	LOW	LOW
G15	A12/SA10	LOW	LOW
G16	D12	LOW	LOW
H1	COL7	HIGH	HIGH
H2	COL6	HIGH	HIGH
H3	COL2	HIGH	HIGH
H4	VSSC		
H5	COL3	HIGH	HIGH
H6	COL4	HIGH	HIGH
H7	COL5	HIGH	HIGH
H8	VSSC		
H9	VSS		
H10	A10/SA8	LOW	LOW
H11	D11	LOW	LOW
H12	A11/SA9	LOW	LOW
H13	VDD		
H14	D10	LOW	LOW
H15	A9/SA7	LOW	LOW
H16	D9	LOW	LOW
J1	TBUZ	LOW	LOW

Table 5. 256-Ball CABGA Package Numerical Pin List

CABGA PIN	SIGNAL	RESET STATE	STANDBY STATE
J2	SSPFRM/nSSPFRM	Input: nSSPFRM	Input
J3	SSPCLK	LOW	LOW
J4	VDDC		
J5	PGMCLK	LOW	LOW
J6	SSPRX	Input	Input
J7	SSPTX	LOW	LOW
J8	VDDC		
J9	VDD		
J10	D8	LOW	LOW
J11	A7/SA5	LOW	LOW
J12	D7	LOW	LOW
J13	A6/SA4	LOW	LOW
J14	VSS		
J15	D6	LOW	LOW
J16	A8/SA6	LOW	LOW
K1	PA0/LCDVD16	Input: PA0	No Change
K2	PA1/LCDVD17	Input: PA1	No Change
K3	PA2	Input	No Change
K4	PA3	Input	No Change
K5	PA5	Input	No Change
K6	PA4	Input	No Change
K7	VSS		
K8	VDDC		
K9	PE1/LCDVD5	Input: PE1	
K10	PD1/LCDVD9	LOW: PD1	
K11	D3	LOW	LOW
K12	A3/SA1	LOW	LOW
K13	A4/SA2	LOW	LOW
K14	D5	LOW	LOW
K15	VDD		
K16	A5/SA3	LOW	LOW
L1	PA6	Input	No Change
L2	PA7	Input	No Change
L3	PB0/UARTRX1	Input: PB0	No Change
L4	VSSC		
L5	PB4/UARTDCD3	Input: PB4	No Change
L6	VDDC		
L7	VDD		
L8	VSS		
L9	VSSC		
L10	VSS		
L11	D0	LOW	LOW
L12	VSS		

Table 5. 256-Ball CABGA Package Numerical Pin List

CABGA PIN	SIGNAL	RESET STATE	STANDBY STATE
L13	D1	LOW	LOW
L14	D2	LOW	LOW
L15	A2/SA0	LOW	LOW
L16	D4	LOW	LOW
M1	PB1/UARTTX3	Input: PB1	LOW if UART3 is Enabled, otherwise No Change
M2	PB2/UARTRX3	Input: PB2	No Change
M3	PB3/UARTCTS3	Input: PB3	No Change
M4	PB7/SMBCLK	Input: PB7	Input if SMB is Enabled, otherwise No Change
M5	PC3/LCDREV	LOW: PC3	No Change
M6	PG0/nPCOE	LOW: PG0	No Change
M7	PH2/nPCSLOTE1	Input: PH2	No Change
M8	LCDVD0	LOW	LOW
M9	PD0/LCDVD8	LOW: PD0	LOW if Dual-Panel LCD is Enabled; otherwise, No Change
M10	VDDA		
M11	VSS		
M12	CLKEN	LOW	LOW
M13	XTAL32OUT	Output	Output
M14	VSS		
M15	A0/nWE1	HIGH: nWE1	HIGH
M16	A1/nWE2	HIGH: nWE2	HIGH
N1	PB5/UARTDSR3	Input: PB5	No Change
N2	PB6/SWID/SMBD	Input: PB6	Input if SMB is Enabled, otherwise No Change
N3	VSSC		
N4	PC5/LCDCLS	LOW: PC5	No Change
N5	PC7/LCDSPL	LOW: PC7	No Change
N6	VDD		
N7	VSSC		
N8	VDD		
N9	LCDDCLK	LOW	LOW
N10	VSSC		
N11	VSSA		
N12	VDD		
N13	VDD		
N14	XTAL32IN	Input	Input
N15	nCS2	HIGH	HIGH
N16	nCS3/nMMSPICS	HIGH: nCS3	HIGH
P1	PC0/UARTTX1	LOW: PC0	No Change
P2	PC1/LCDPS	LOW: PC1	No Change
P3	PC4/LCDSPS	LOW: PC4	No Change
P4	PG2/nPCIOR	LOW: PG2	No Change
P5	PG5/nPCCE1	LOW: PG5	No Change
P6	PH0/PCRESET1	Input: PH0	No Change

Table 5. 256-Ball CABGA Package Numerical Pin List

CABGA PIN	SIGNAL	RESET STATE	STANDBY STATE
P7	PH6/AC97RESET	Input: PH6	No Change
P8	LCDVD1	LOW	LOW
P9	LCDENAB/LCDM	LOW: LCDENAB	LOW
P10	PD2/LCDVD10	LOW: PD2	No Change
P11	VDD		No Change
P12	VDDA		
P13	nTEST1	Input with Pull-up	Input with Pull-up
P14	nCS0	HIGH	HIGH
P15	nTEST0	Input with Pull-up	Input with Pull-up
P16	nCS1	HIGH	HIGH
R1	PC2/LCDVDDEN	LOW: PC2	No Change
R2	PC6/LCDHRLP	LOW: PC6	No Change
R3	PG3/nPCIOW	LOW: PG3	No Change
R4	PG6/nPCCE2	LOW: PG6	No Change
R5	VSSC		
R6	PH4/nPCWAIT1	Input: PH4	No Change
R7	PH5/CFA10/PCMCIAA24/nPCWAIT2	Input: PH5	No Change
R8	LCDVD2	LOW	LOW
R9	LCDLP	LOW	LOW
R10	PE3/LCDVD7	Input: PE3	No Change
R11	PD5/LCDVD13	LOW: PD5	No Change
R12	PD6/LCDVD14	LOW: PD6	No Change
R13	VSSA		
R14	XTALIN	Input	Input
R15	XTALOUT	LOW	LOW
R16	USBDN	Input	Input
T1	PG1/nPCWE	LOW: PG1	No Change
T2	PG4/nPCREG	LOW: PG4	No Change
T3	PG7/PCDIR	LOW: PG7	No Change
T4	PH1/CFA8/PCRESET2	Input: PH1	No Change
T5	PH3/CFA9/PCMCIAA25/nPCSLOTE2	Input: PH3	No Change
T6	PH7/nPCSTATRE	Input: PH7	No Change
T7	LCDFP	LOW	LOW
T8	LCDVD3	LOW	LOW
T9	PE0/LCDVD4	Input: PE0	LOW if 8-bit LCD is Enabled, otherwise No Change
T10	PE2/LCDVD6	Input: PE2	No Change
T11	PD3/LCDVD11	LOW: PD3	No Change
T12	PD4/LCDVD12	LOW: PD4	No Change
T13	PD7/LCDVD15	LOW: PD7	No Change
T14	WIDTH0	Input (Schmitt)	Input
T15	WIDTH1	Input (Schmitt)	Input
T16	USBDP	Input	Input

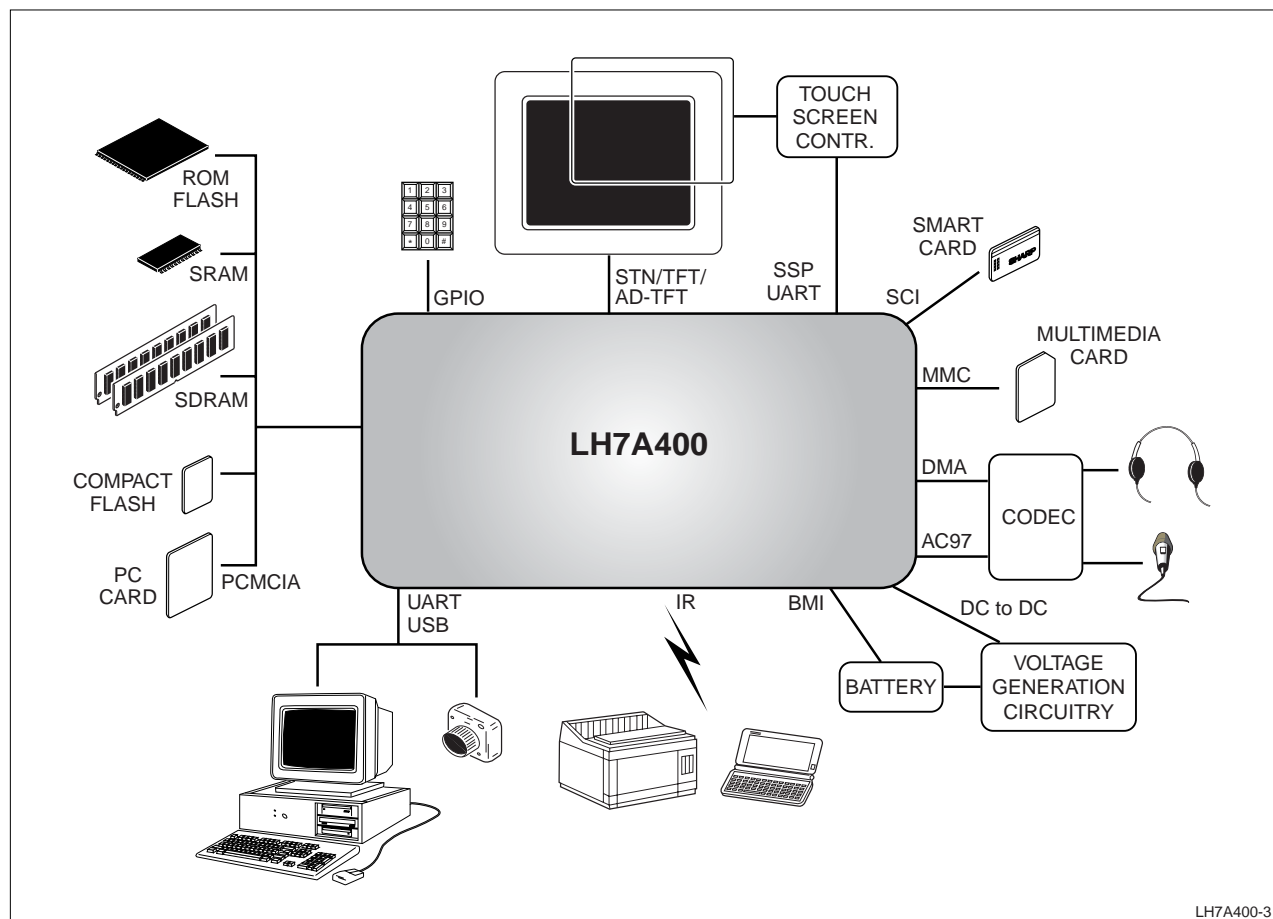

Figure 2. Application Diagram

SYSTEM DESCRIPTIONS

ARM922T Processor

The LH7A400 microcontroller features the ARM922T cached core with an Advanced High Performance Bus (AHB) interface. The processor is a member of the ARM9T family of processors. For more information, see the ARM document, 'ARM922T Technical Reference Manual', available on ARM's website at www.arm.com.

Clock and State Controller

The clocking scheme in the LH7A400 is based around two primary oscillator inputs. These are the 14.7456 MHz input crystal and the 32.768 kHz real time clock oscillator. See Figure 3. The 14.7456 MHz oscillator is used to generate the main system clock domains for the LH7A400, whereas the 32.768 kHz is used for controlling the power down operations and real time clock peripheral. The clock and state controller provides the clock gating and frequency division necessary, and then supplies the clocks to the processor and to the rest of the system. The amount of clock gating that actually takes place is dependent on the current power saving mode selected.

The 32.768 kHz clock provides the source for the Real Time Clock tree and power-down logic. This clock is used for the power state control in the design and is the only clock in the LH7A400 that runs permanently. The 32.768 kHz clock is divided down to 1 Hz using a ripple divider to save power. This generated 1 Hz clock is used in the Real Time Clock counter.

The 14.7456 MHz source is used to generate the main system clocks for the LH7A400. It is the source for PLL1 and PLL2, it acts as the primary clock to the peripherals and is the source clock to the Programmable clock (PGM) divider.

PLL1 provides the main clock tree for the chip, it generates the following clocks: FCLK, HCLK and PCLK. FCLK is the clock that drives the ARM922T core. HCLK is the main bus (AHB) clock, as such it clocks all memory interfaces, bus arbitrators and the AHB peripherals. HCLK is generated by dividing FCLK by 1, 2, 3, or 4. HCLK can be gated by the system to enable low power operation. PCLK is the peripheral bus (APB) clock. It is generated by dividing HCLK by either 2, 4, or 8.

PLL2 is used to generate a fixed frequency of 48 MHz for the USB peripheral.

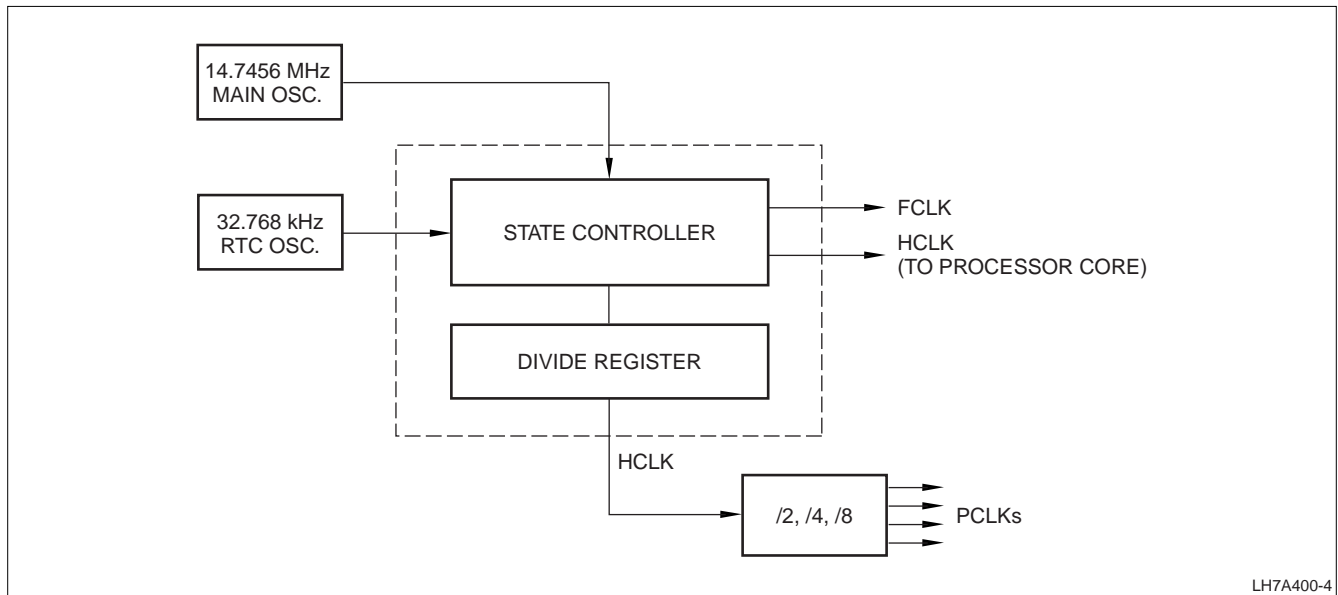

Figure 3. Clock and State Controller Block Diagram

Power Modes

The LH7A400 has three operational states: Run, Halt, and Standby. In Run mode, all clocks are hardware-enabled and the processor is clocked. Halt mode stops the processor clock while waiting for an event such as a key press, but the device continues to function. Finally, Standby equates to the computer being switched 'off', i.e. no display (LCD disabled) and the main oscillator is shut down. The 32.768 kHz oscillator operates in all three modes.

Reset Modes

There are three external signals that can generate resets to the LH7A400; these are nPOR (power on reset), nPWRFL (power failure) and nURESET (user reset). If any of these are active, a system reset is generated internally. A nPOR reset performs a full system reset. The nPWRFL and nURESET resets will perform a full system reset except for the SDRAM refresh control, SDRAM Global Configuration, SDRAM Device Configuration and the RTC peripheral registers. The SDRAM controller will issue a self-refresh command to external SDRAM before the system enters this reset (the nPWRFL and nURESET resets only, not so for the nPOR reset). This allows the system to maintain its Real Time Clock and SDRAM contents. On coming out of reset, the chip enters Standby mode. Once in Run mode the PWRSR register can be interrogated to determine the nature of the reset, and the trigger source, after which software can then take appropriate actions.

Data Paths

The data paths in the LH7A400 are:

- The AMBA AHB bus
- The AMBA APB bus
- The External Bus Interface
- The LCD AHB bus
- The DMA busses.

AMBA AHB BUS

The Advanced Microprocessor Bus Architecture Advanced High-performance Bus (AMBA AHB) bus is a high speed 32-bit-wide data bus. The AMBA AHB is for high-performance, high clock frequency system modules.

Peripherals that have high bandwidth requirements are connected to the LH7A400 core processor using the AHB bus. These include the external and internal memory interfaces, the LCD registers, palette RAM and the bridge to the Advanced Peripheral Bus (APB) interface. The APB Bridge transparently converts the AHB access into the slower speed APB accesses. All of the control registers for the APB peripherals are programmed using the AHB - APB bridge interface. The main AHB data and address lines are configured using a multiplexed bus. This removes the need for tri-state buffers and bus holders, and simplifies bus arbitration.

AMBA APB BUS

The AMBA APB bus is a lower-speed 32-bit-wide peripheral data bus. The speed of this bus is selectable to be a divide-by-2, divide-by-4 or divide-by-8 of the speed of the AHB bus.

EXTERNAL BUS INTERFACE

The External Bus Interface (EBI) provides a 32-bit wide, high speed gateway to external memory devices. The memory devices supported include:

- Asynchronous RAM/ROM/Flash
- Synchronous DRAM/Flash
- PCMCIA interfaces
- CompactFlash interfaces.

The EBI can be controlled by either the Asynchronous memory controller or Synchronous memory controller. There is an arbiter on the EBI input, with priority given to the Synchronous Memory Controller interface.

LCD AHB BUS

The LCD controller has its own local memory bus that connects it to the system's embedded memory and external SDRAM. The function of this local data bus is to allow the LCD controller to perform its video refresh function without congesting the AHB bus. This leads to better system performance and lower power consumption. There is an arbiter on both the embedded memory and the synchronous memory controller. In both cases the LCD bus is given priority.

DMA BUSES

The LH7A400 has a DMA system that connects the higher speed/higher data volume APB peripherals (MMC, USB and AC97) to the AHB bus. This enables the efficient transfer of data between these peripherals and external memory without the intervention of the ARM922T core. The DMA engine does not support memory to memory transfers.

Memory Map

The LH7A400 system has a 32-bit-wide address bus. This allows it to address up to 4GB of memory. This memory space is subdivided into a number of memory banks; see Figure 4. Four of these banks (each of 256MB) are allocated to the Synchronous memory controller. Eight of the banks (again, each 256MB) are allocated to the Asynchronous memory controller. Two of these eight banks are designed for PCMCIA systems. Part of the remaining memory space is allocated to the embedded SRAM, and to the control registers of the AHB and APB. The rest is unused.

The LH7A400 can boot from either synchronous or asynchronous ROM/Flash. The selection is determined by the value of the MEDCHG pin at Power On Reset as shown in Table 6. When booting from synchronous memory, then synchronous bank 4 (nSCS3) is mapped into memory location zero. When booting from asynchronous memory, asynchronous memory bank 0 (nSCS0) is mapped into memory location zero.

Figure 4 shows the memory map of the LH7A400 system for the two boot modes.

Once the LH7A400 has booted, the boot code can configure the ARM922T MMU to remap the low memory space to a location in RAM. This allows the user to set the interrupt vector table.

Table 6. Boot Modes

BOOT MODE	LATCHED BOOT-WIDTH1	LATCHED BOOT-WIDTH0	LATCHED MEDCHG
8-bit ROM	0	0	0
16-bit ROM	0	1	0
32-bit ROM	1	0	0
32-bit ROM	1	1	0
16-bit SFlash (Initializes Mode Register)	0	0	1
16-bit SROM (Initializes Mode Register)	0	1	1
32-bit SFlash (Initializes Mode Register)	1	0	1
32-bit SROM (Initializes Mode Register)	1	1	1

Interrupt Controller

The LH7A400 interrupt controller is designed to control the interrupts from 28 different sources. Four interrupt sources are mapped to the FIQ input of the ARM922T and 24 are mapped to the IRQ input. FIQs have a higher priority than the IRQs. If two interrupts with the same priority become active at the same time, the priority must be resolved in software.

When an interrupt becomes active, the interrupt controller generates an FIQ or IRQ if the corresponding mask bit is set. No latching of interrupts takes place in the controller. After a Power On Reset all mask register bits are cleared, therefore masking all interrupts. Hence, enabling of the mask register must be done by software after a power-on-reset.

F000.0000	ASYNCHRONOUS MEMORY (nCS0)	SYNCHRONOUS MEMORY (nSCS3)	256MB
E000.0000	SYNCHRONOUS MEMORY (nSCS2)	SYNCHRONOUS MEMORY (nSCS2)	256MB
D000.0000	SYNCHRONOUS MEMORY (nSCS1)	SYNCHRONOUS MEMORY (nSCS1)	256MB
C000.0000	SYNCHRONOUS MEMORY (nSCS0)	SYNCHRONOUS MEMORY (nSCS0)	256MB
B001.4000	RESERVED	RESERVED	
B000.0000	EMBEDDED SRAM	EMBEDDED SRAM	80KB
8000.3800	RESERVED	RESERVED	
8000.2000	AHB INTERNAL REGISTERS	AHB INTERNAL REGISTERS	
8000.0000	APB INTERNAL REGISTERS	APB INTERNAL REGISTERS	
7000.0000	ASYNCHRONOUS MEMORY (CS7)	ASYNCHRONOUS MEMORY (CS7)	256MB
6000.0000	ASYNCHRONOUS MEMORY (CS6)	ASYNCHRONOUS MEMORY (CS6)	256MB
5000.0000	PCMCIA/CompactFlash (nPCSLOTE2)	PCMCIA/CompactFlash (nPCSLOTE2)	256MB
4000.0000	PCMCIA/CompactFlash (nPCSLOTE1)	PCMCIA/CompactFlash (nPCSLOTE1)	256MB
3000.0000	ASYNCHRONOUS MEMORY (nCS3)	ASYNCHRONOUS MEMORY (nCS3)	256MB
2000.0000	ASYNCHRONOUS MEMORY (nCS2)	ASYNCHRONOUS MEMORY (nCS2)	256MB
1000.0000	ASYNCHRONOUS MEMORY (nCS1)	ASYNCHRONOUS MEMORY (nCS1)	256MB
0000.0000	SYNCHRONOUS ROM (nSCS3)	ASYNCHRONOUS ROM (nCS0)	256MB
SYNCHRONOUS MEMORY BOOT		ASYNCHRONOUS MEMORY BOOT	

LH7A400-6

Figure 4. Memory Mapping for Each Boot Mode

External Bus Interface

The external bus interface allows the ARM922T, LCD controller and DMA engine access to an external memory system. The LCD controller has access to an internal frame buffer in embedded SRAM and an extension buffer in Synchronous Memory for large displays. The processor and DMA engine share the main system bus, providing access to all external memory devices and the embedded SRAM frame buffer.

An arbitration unit ensures that control over the External Bus Interface (EBI) is only granted when an existing access has been completed. See Figure 5.

Embedded SRAM

The amount of Embedded SRAM contained in the LH7A400 is 80KB. This Embedded memory is designed to be used for storing code, data, or LCD frame data and to be contiguous with external SDRAM. The 80KB is large enough to store a QVGA panel (320 × 240) at 8 bits per pixel, equivalent to 70KB of information.

Containing the frame buffer on chip reduces the overall power consumed in any application that uses the LH7A400. Normally, the system has to perform external accesses to acquire this data. The LCD controller is designed to automatically use an overflow frame buffer in SDRAM if a larger screen size is required. This overflow buffer can be located on any 4KB page boundary in SDRAM, allowing software to

set the MMU (in the LCD controller) page tables such that the two memory areas appear contiguous. Byte, Half-Word and Word accesses are permissible.

Asynchronous Memory Controller

The Asynchronous memory controller is incorporated as part of the memory controller to provide an interface between the AMBA AHB system bus and external (off-chip) memory devices.

The Asynchronous Memory Controller provides support for up to eight independently configurable memory banks simultaneously. Each memory bank is capable of supporting:

- SRAM
- ROM
- Flash EPROM
- Burst ROM memory.

Each memory bank may use devices using either 8-, 16-, or 32-bit external memory data paths. The memory controller can be configured to support either little-endian or big-endian operation.

The memory banks can be configured to support:

- Non-burst read and write accesses only to high-speed CMOS static RAM.
- Non-burst write accesses, nonburst read accesses and asynchronous page mode read accesses to fast-boot block flash memory.

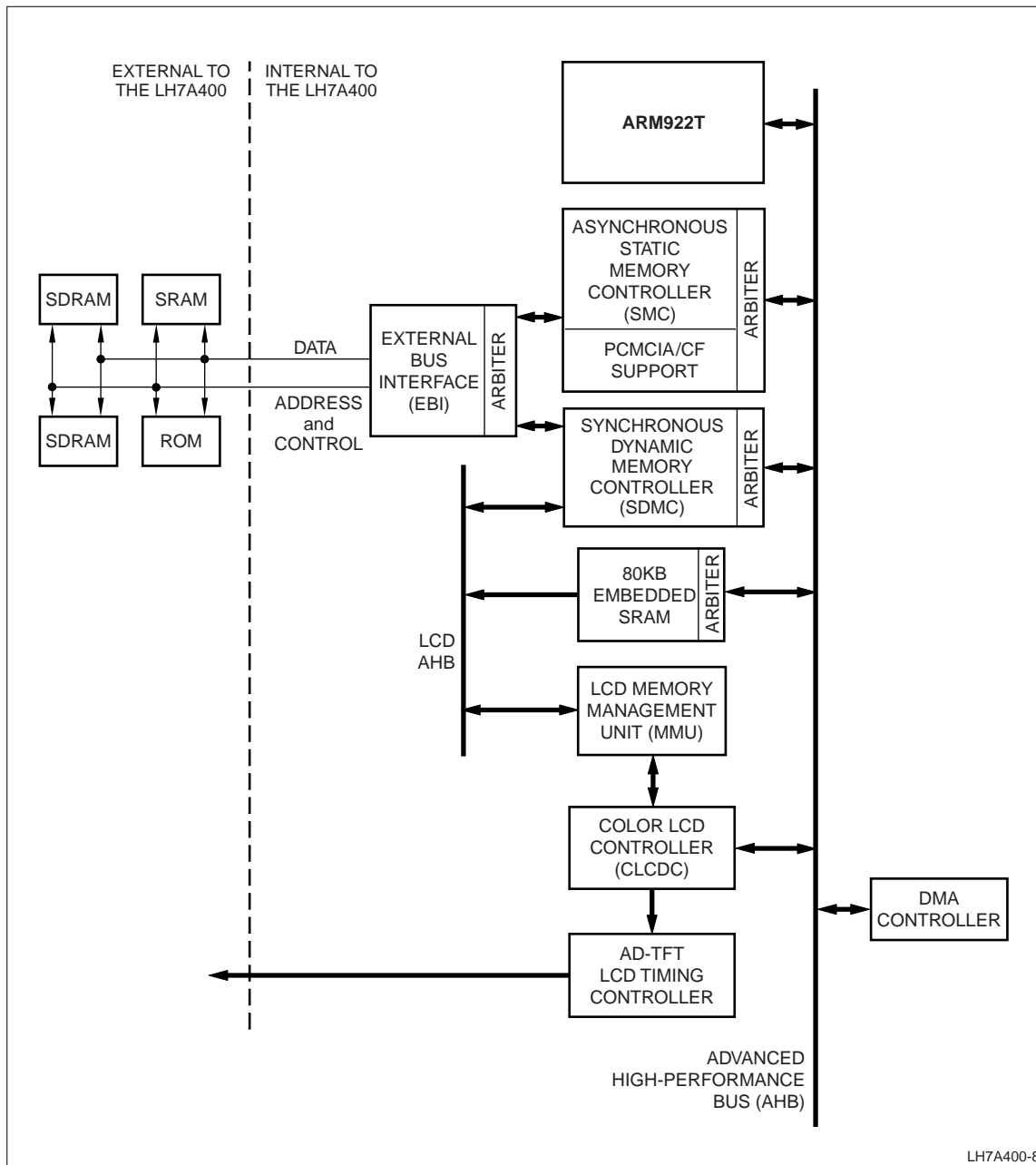

Figure 5. External Bus Interface Block Diagram

The Asynchronous Memory Controller has six main functions:

- Memory bank select
- Access sequencing
- Wait states generation
- Byte lane write control
- External bus interface
- CompactFlash or PCMCIA interfacing.

Synchronous Memory Controller

The Synchronous memory controller provides a high speed memory interface to a wide variety of Synchronous memory devices, including SDRAM, Synchronous Flash and Synchronous ROMs.

The key features of the controller are:

- LCD DMA port for high bandwidth
- Up to four Synchronous Memory banks that can be independently set up
- Special configuration bits for Synchronous ROM operation
- Ability to program Synchronous Flash devices using write and erase commands
- On booting from Synchronous ROM, (and optionally with Synchronous Flash), a configuration sequence is performed before releasing the processor from reset
- Data is transferred between the controller and the SDRAM in quad-word bursts. Longer transfers within the same page are concatenated, forming a seamless burst
- Programmable for 16- or 32-bit data bus size
- Two reset domains are provided to enable SDRAM contents to be preserved over a 'soft' reset
- Power saving Synchronous Memory SCKE and external clock modes provided.

MultiMediaCard (MMC)

The MMC adapter combines all of the requirements and functions of an MMC host. The adapter supports the full MMC bus protocol, defined by the MMC Definition Group's specification v.2.11. The controller can also implement the SPI interface to the cards.

INTERFACE DESCRIPTION AND MMC OVERVIEW

The MMC controller uses the three-wire serial data bus (clock, command, and data) to transfer data to and from the MMC card, and to configure and acquire status information from the card's registers.

MMC bus lines can be divided into three groups:

- Power supply: VDD and VSS
- Data Transfer: MMCCMD, MMCDATA
- Clock: MMCLK.

MULTIMEDIACARD ADAPTER

The MultiMediaCard Adapter implements MultiMediaCard specific functions, serves as the bus master for the MultiMediaCard Bus and implements the standard interface to the MultiMediaCard Cards (card initialization, CRC generation and validation, command/response transactions, etc.).

Smart Card Interface (SCI)

The SCI (ISO7816) interfaces to an external Smart Card reader. The SCI can autonomously control data transfer to and from the smart card. Transmit and receive data FIFOs are provided to reduce the required interaction between the CPU core and the peripheral.

SCI FEATURES

- Supports asynchronous T0 and T1 transmission protocols
- Supports clock rate conversion factor $F = 372$, with bit rate adjustment factors $D = 1, 2, \text{ or } 4$ supported
- Eight-character-deep buffered Tx and Rx paths
- Direct interrupts for Tx and Rx FIFO level monitoring
- Interrupt status register
- Hardware-initiated card deactivation sequence on detection of card removal
- Software-initiated card deactivation sequence on transaction complete
- Limited support for synchronous Smart Cards via registered input/output.

PROGRAMMABLE PARAMETERS

- Smart Card clock frequency
- Communication baud rate
- Protocol convention
- Card activation/deactivation time
- Check for maximum time for first character of Answer to Reset - ATR reception
- Check for maximum duration of ATR character stream
- Check for maximum time of receipt of first character of data stream
- Check for maximum time allowed between characters
- Character guard time
- Block guard time
- Transmit/receive character retry.

Direct Memory Access Controller (DMA)

The DMA Controller interfaces streams from the following three peripherals to the system memory:

- USB (1 Tx and 1 Rx DMA Channel)
- MMC (1 Tx and 1 Rx DMA Channel)
- AC97 (3 Tx and 3 Rx DMA Channels).

Each has its own bi-directional peripheral DMA bus capable of transferring data in both directions simultaneously. All memory transfers take place via the main system AHB bus.

DMA Specific features are:

- Independent DMA channels for Tx and Rx
- Two Buffer Descriptors per channel to avoid potential data under/over-flows due to software introduced latency
- No Buffer wrapping
- Buffer size may be equal to, greater than or less than the packet size. Transfers can automatically switch between buffers.
- Maskable interrupt generation
- Internal arbitration between DMA Channels and external bus arbiter.
- For DMA Data transfer sizes, byte, word and quad-word data transfers are supported.

A set of control and status registers are available to the system processor for setting up DMA operations and monitoring their status. A system interrupt is generated when any or all of the DMA channels wish to inform the processor that a new buffer needs to be allocated. The DMA controller services three peripherals using ten DMA channels, each with its own peripheral DMA bus capable of transferring data in both directions simultaneously.

The MMC and USB peripherals each use two DMA channels, one for transmit and one for receive. The AC97 peripheral uses six DMA channels (three transmit and three receive) to allow different sample frequency data queues to be handled with low software overheads. The DMA Controller does not support memory to memory transfers.

USB Device

The features of the USB are:

- Fully compliant to USB 1.1 specification
- Provides a high level interface that shields the firmware from USB protocol details
- Compatible with both OpenHCI and Intel's UHCI standards
- Supports full-speed (12 Mbps) functions
- Supports Suspend and Resume signalling.

Color LCD Controller

The LH7A400's LCD Controller is programmable to support up to 1,024 × 768, 16-bit color LCD panels. It interfaces directly to STN, color STN, TFT, AD-TFT, and HR-TFT panels. Unlike other LCD controllers, the LH7A400's LCD Controller incorporates the timing conversion logic from TFT to HR-TFT, allowing a direct interface to HR-TFT and minimizing external chip count.

The Color LCD Controller features support for:

- Up to 1,024 × 768 Resolution
- 16-bit Video Bus
- STN, Color STN, AD-TFT, HR-TFT, TFT panels
- Single and Dual Scan STN panels
- Up to 15 Gray Shades
- Up to 64,000 Colors

AC97 Advanced Audio Codec Interface

The AC97 Advanced Audio Codec controller includes a 5-pin serial interface to an external audio codec. The AC97 LINK is a bi-directional, fixed rate, serial Pulse Code Modulation (PCM) digital stream, dividing each audio frame into 12 outgoing and 12 incoming data streams (slots), each with 20-bit sample resolution.

The AC97 controller contains logic that controls the AC97 link to the Audio Codec and an interface to the AMBA APB.

Its main features include:

- Serial-to-parallel conversion for data received from the external codec
- Parallel-to-serial conversion for data transmitted to the external codec
- Reception/Transmission of control and status information via the AMBA APB interface
- Supports up to 4 different codec sampling rates at a time with its 4 transmit and 4 receive channels. The transmit and receive paths are buffered with internal FIFO memories, allowing data to be stored independently in both transmit and receive modes. The outgoing data for the FIFOs can be written via either the APB interface or with DMA channels 1 - 3.

Audio Codec Interface (ACI)

The ACI provides:

- A digital serial interface to an off-chip 8-bit CODEC
- All the necessary clocks and timing pulses to perform serialization or de-serialization of the data stream to or from the CODEC device.

The interface supports full duplex operation and the transmit and receive paths are buffered with internal FIFO memories allowing up to 16 bytes to be stored independently in both transmit and receive modes.

The ACI includes a programmable frequency divider that generates a common transmit and receive bit clock output from the on-chip ACI clock input (ACICLK). Transmit data values are output synchronous with the rising edge of the bit clock output. Receive data values are sampled on the falling edge of the bit clock output. The start of a data frame is indicated by a synchronization output signal that is synchronous with the bit clock.

Synchronous Serial Port (SSP)

The LH7A400 SSP is a master-only interface for synchronous serial communication with device peripheral devices that has either Motorola SPI, National Semiconductor MICROWIRE or Texas Instruments Synchronous Serial Interfaces.

The LH7A400 SSP performs serial-to-parallel conversion on data received from a peripheral device. The transmit and receive paths are buffered with internal FIFO memories allowing up to eight 16-bit values to be stored independently in both transmit and receive modes. Serial data is transmitted on SSPTXD and received on SSPRXD.

The LH7A400 SSP includes a programmable bit rate clock divider and prescaler to generate the serial output clock SCLK from the input clock SSPCLK. Bit rates are supported to 2 MHz and beyond, subject to choice of frequency for SSPCLK; the maximum bit rate will usually be determined by peripheral devices.

UART/IrDA

The LH7A400 contains three UARTs, UART1, UART2, and UART3.

The UART performs:

- Serial-to-Parallel conversion on data received from the peripheral device
- Parallel-to-Serial conversion on data transmitted to the peripheral device.

The transmit and receive paths are buffered with internal FIFO memories allowing up to 16 bytes to be stored independently in both transmit and receive modes.

The UART can generate:

- Four individually maskable interrupts from the receive, transmit and modem status logic blocks
- A single combined interrupt so that the output is asserted if any of the individual interrupts are asserted and unmasked.

If a framing, parity or break error occurs during reception, the appropriate error bit is set, and is stored in the FIFO. If an overrun condition occurs, the overrun register bit is set immediately and the FIFO data is prevented from being overwritten. UART1 also supports IrDA 1.0 (15.2 kbit/s).

The modem status input signals Clear to Send (CTS), Data Carrier Detect (DCD) and Data Set Ready (DSR) are supported on UART2 and UART3.

Timers

Two identical timers are integrated in the LH7A400. Each of these timers has an associated 16-bit read/write data register and a control register. Each timer is loaded with the value written to the data register immediately, this value will then be decremented on the next active clock edge to arrive after the write. When the timer underflows, it will immediately assert its appropriate interrupt. The timers can be read at any time. The clock source and mode is selectable by writing to various bits in the system control register. Clock sources are 508 kHz and 2 kHz.

Timer 3 (TC3) has the same basic operation, but is clocked from a single 7.3728 MHz source. It has the same register arrangement as Timer 1 and Timer 2, providing a load, value, control and clear register. Once the timer has been enabled and is written to, unlike the Timer 1 and Timer 2, will decrement the timer on the next rising edge of the 7.3728 MHz clock after the data register has been updated. All the timers can operate in two modes, free running mode or pre-scale mode.

FREE-RUNNING MODE

In free-running mode, the timer will wrap around to 0xFFFF when it underflows and continue counting down.

PRE-SCALE MODE

In pre-scale (periodic) mode, the value written to each timer is automatically re-loaded when the timer underflows. This mode can be used to produce a programmable frequency to drive the buzzer or generate a periodic interrupt.

Real Time Clock (RTC)

The RTC can be used to provide a basic alarm function or long time-base counter. This is achieved by generating an interrupt signal after counting for a programmed number of cycles of a real-time clock input. Counting in one second intervals is achieved by use of a 1 Hz clock input to the RTC.

Battery Monitor Interface (BMI)

The LH7A400 BMI is a serial communication interface specified for two types of Battery Monitors/Gas Gauges. The first type employs a single wire interface. The second interface employs a two-wire multi-master bus, the Smart Battery System Specification. If both interfaces are enabled at the same time, the Single Wire Interface will have priority. A brief overview of these two interface types are given here.

SINGLE WIRE INTERFACE

The Single Wire Interface performs:

- Serial-to-parallel conversion on data received from the peripheral device
- Parallel-to-serial conversion on data transmitted to the peripheral device
- Data packet coding/decoding on data transfers (incorporating Start/Data/Stop data packets)

The Single Wire interface uses a command-based protocol, in which the host initiates a data transfer by sending a WriteData/Command word to the Battery Monitor. This word will always contain the Command section, which tells the Single Wire Interface device the location for the current transaction. The most significant bit of the Command determines if the transaction is Read or Write. In the case of a Write transaction, then the word will also contain a WriteData section with the data to be written to the peripheral.

SMART BATTERY INTERFACE

The SMBus Interface performs:

- Serial-to-Parallel conversion on data received from the peripheral device
- Parallel-to-Serial conversion of data transmitted to the peripheral device.

The Smart Battery Interface uses a two-wire multi-master bus (the SMBus), meaning that more than one device capable of controlling the bus can be connected to it. A master device initiates a bus transfer and provides the clock signals. A slave device can receive data provided by the master or it can provide data to the master. Since more than one device may attempt to take control of the bus as a master, SMBus provides an arbitration mechanism, by relying on the wired-AND connection of all SMBus interfaces to the SMBus.

DC-to-DC Converter

The features of the DC-DC Converter interface are:

- Dual drive PWM outputs, with independent closed loop feedback
- Software programmable configuration of one of 8 output frequencies (each being a fixed divide of the input clock).
- Software programmable configuration of duty cycle from 0 to 15/16, in intervals of 1/16.
- Output polarity (for positive or negative voltage generation) is hardware-configured during power-on reset via the polarity select inputs
- Each PWM output can be dynamically switched to one of a pair of preprogrammed frequency/duty cycle combinations via external pins.

Watchdog Timer (WDT)

The Watchdog Timer provides hardware protection against malfunctions. It is a programmable timer that is reset by software at regular intervals. Failure to reset the timer will cause a FIQ interrupt. Failure to service the FIQ interrupt will then generate a System Reset. The WDT features are:

- Driven by the system clock
- 16 programmable time-out periods: 2^{16} through 2^{31} clock cycles
- Generates a system reset (resets LH7A400) or a FIQ Interrupt whenever a time-out period is reached
- Software enable, lockout, and counter-reset mechanisms add security against inadvertent writes
- Protection mechanism guards against interrupt-service-failure:
 - The first WDT time-out triggers FIQ and asserts nWDFIQ status flag
 - If FIQ service routine fails to clear nWDFIQ, then the next WDT time-out triggers a System Reset.

General Purpose I/O (GPIO)

The LH7A400 GPIO has eight ports, each with a data register and a data direction register. It also has added registers including Keyboard Scan, PINMUX, GPIO Interrupt Enable, INTYPE1/2, GPIOFEOI and PGHCON.

The data direction register determines whether a port is configured as an input or an output while the data register is used to read the value of the GPIO pins.

The GPIO Interrupt Enable, INTYPE1/2, and GPIOFEOI registers are used to control edge-triggered Interrupts on Port F. The PINMUX register controls what signals are output of Port D and Port E when they are set as outputs, while the PGHCON controls the operations of Port G and H.

ELECTRICAL SPECIFICATIONS

Absolute Maximum Ratings

PARAMETER	MINIMUM	MAXIMUM
DC Core Supply Voltage (VDDC)	-0.3 V	2.4 V
DC I/O Supply Voltage (VDD)	-0.3 V	4.6 V
DC Analog Supply Voltage (VDDA)	-0.3 V	2.4 V
Storage Temperature	-55°C	125°C

NOTE: These ratings are only for transient conditions. Operation at or beyond absolute maximum rating conditions may affect reliability and cause permanent damage to the device.

Recommended Operating Conditions

PARAMETER	MINIMUM	TYPICAL	MAXIMUM	NOTES
DC Core Supply Voltage (VDDC)	1.71 V	1.8 V	1.89 V	1
DC I/O Supply Voltage (VDD)	3.0 V	3.3 V	3.6 V	2
DC Analog Supply Voltage for PLLs (VDDA)	1.71 V	1.8 V	1.89 V	
Clock Frequency (Commercial)	10 MHz		200 MHz	3, 4, 5
Clock Frequency (Industrial)	10 MHz		195 MHz	3, 4, 5
External Clock Input (XTALIN)	14 MHz	14.7456 MHz	20 MHz	6
Operating Temperature (Commercial)	0°C	25°C	70°C	
Operating Temperature (Industrial)	-40°C	25°C	+85°C	

NOTES:

1. Core Voltage should never exceed I/O Voltage.
2. USB is not functional below 3.0 V.
3. Using 14.7456 MHz Main Oscillator Crystal and 32.768 kHz RTC Oscillator Crystal.
4. VDDC = 1.71 V to 1.89 V.
5. VDD = 3.0 V to 3.6 V.
6. IMPORTANT: Most peripherals will NOT function at clock speeds other than 14.7456 MHz.

Table 7. Clock Frequency vs. Voltages (VDD) vs. Temperature

PARAMETER		1.71 V	1.8 V	1.89 V
25°C	Clock Frequency (f _{HCLK})	211 MHz	225 MHz	240 MHz
	Clock Period (t _{HCLK})	4.74 ns	4.44 ns	4.17 ns
70°C	Clock Frequency (f _{HCLK})	200 MHz	212 MHz	227 MHz
	Clock Period (t _{HCLK})	5.00 ns	4.72 ns	4.41 ns
85°C	Clock Frequency (f _{HCLK})	195 MHz	208 MHz	222 MHz
	Clock Period (t _{HCLK})	5.13 ns	4.81 ns	4.50 ns

Table 7 is representative of a typical wafer process. Guaranteed values are in the Recommended Operating Conditions table.

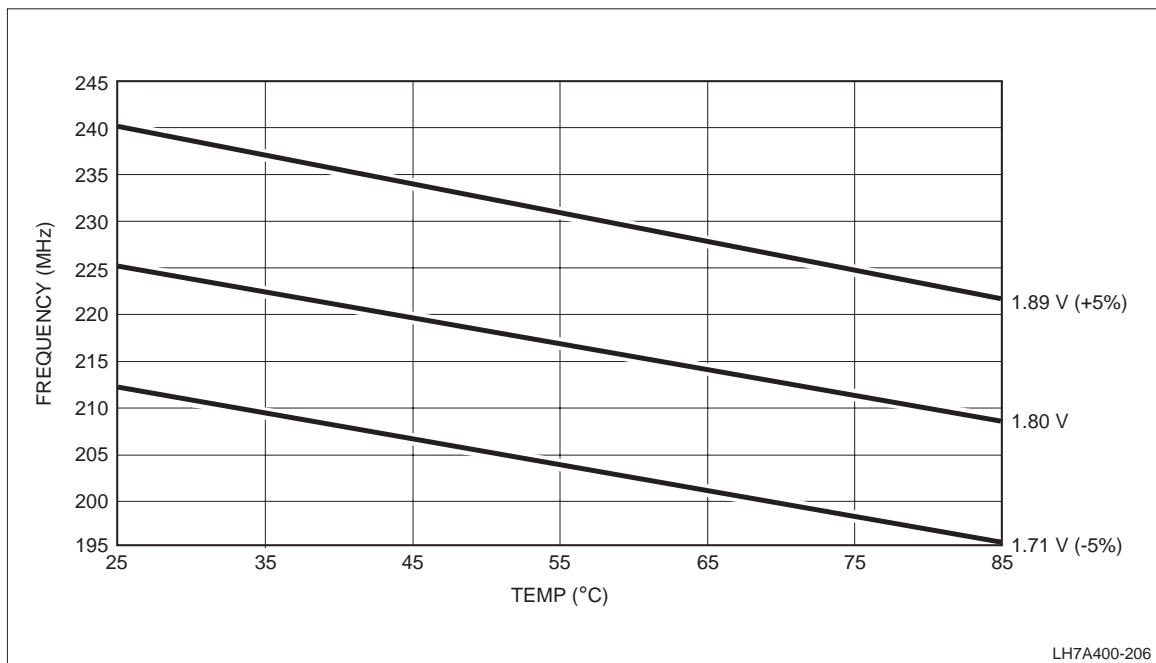

Figure 6. Temperature/Voltage/Speed Chart

DC/AC SPECIFICATIONS (COMMERCIAL AND INDUSTRIAL)

Unless otherwise noted, all data provided under commercial DC/AC specifications are based on -40°C to +85°C, VDDC = 1.71 V to 1.89 V, VDD = 3.0 V to 3.6 V, VDDA = 1.71 V to 1.89 V.

DC Specifications

SYMBOL	PARAMETER	MIN.	TYP.	MAX.	UNIT	CONDITIONS	NOTES
VIH	CMOS and Schmitt Trigger Input HIGH Voltage	2.0			V		
VIL	CMOS and Schmitt Trigger Input LOW Voltage			0.8	V		
VHST	Schmitt Trigger Hysteresis	0.25			V	VIL to VIH	
VOH	CMOS Output HIGH Voltage, Output Drive 1	2.6			V	IOH = -2 mA	
	Output Drive 2	2.6			V	IOH = -4 mA	
	Output Drive 3	2.6			V	IOH = -8 mA	
	Output Drive 4 and 5	2.6			V	IOH = -12 mA	1
VOL	CMOS Output LOW Voltage, Output Drive 1			0.4	V	IOL = 2 mA	
	Output Drive 2			0.4	V	IOL = 4 mA	
	Output Drive 3			0.4	V	IOL = 8 mA	
	Output Drive 4			0.4	V	IOL = 12 mA	
	Output Drive 5			0.4	V	IOL = 20 mA	1
IIN	Input Leakage Current	-10		10	μA	VIN = VDD or GND	
IIN	Input Leakage Current (with pull-up resistors installed)	-200		-20	μA	VIN = VDD or GND	
IOZ	Output Tri-state Leakage Current	-10		10	μA	VOUT = VDD or GND	
ISTARTUP	Startup Current			50	μA		2
IACTIVE	Active Current		125	180	mA		
IHALT	Halt Current		25	41	mA		
ISTANDBY	Standby Current		42		μA		
CIN	Input Capacitance			4	pF		
COUT	Output Capacitance			4	pF		

NOTES:

- Output Drive 5 can sink 20 mA of current, but sources 12 mA of current.
- Current consumption until oscillators are stabilized.

AC Test Conditions

PARAMETER	RATING	UNIT
DC I/O Supply Voltage (VDD)	3.0 to 3.6	V
DC Core Supply Voltage (VDDC)	1.71 to 1.89	V
Input Pulse Levels	VSS to 3	V
Input Rise and Fall Times	2	ns
Input and Output Timing Reference Levels	VDD/2	V

CURRENT CONSUMPTION BY OPERATING MODE

Current consumption can depend on a number of parameters. To make this data more usable, the values presented in Table 8 were derived under the conditions presented here.

Maximum Specified Value

The values specified in the MAXIMUM column were determined using these operating characteristics:

- All IP blocks either operating or enabled at maximum frequency and size configuration
- Core operating at maximum power configuration
- All voltages at maximum specified values
- Maximum specified ambient temperature.

Typical

The values in the TYPICAL column were determined using a 'typical' application under 'typical' environmental conditions and the following operating characteristics:

- LINUX operating system running from SDRAM
- UART and AC97 peripherals operating; all other peripherals as needed by the OS
- LCD enabled with 320 × 240 × 16-bit color, 60 Hz refresh rate, data in SDRAM
- I/O loads at nominal
- Cache enabled
- FCLK = 200 MHz; HCLK = 100 MHz; PCLK = 50 MHz
- All voltages at typical values
- Nominal case temperature.

Table 8. Current Consumption by Mode

SYMBOL	PARAMETER	TYP.	MAX.	UNITS
ACTIVE MODE				
ICORE	Current drawn by core	110	135	mA
IIO	Current drawn by I/O	15	45	mA
HALT MODE (ALL PERIPHERALS DISABLED)				
ICORE	Current drawn by core	24	39	mA
IIO	Current drawn by I/O	1	2	mA
STANDBY MODE (TYPICAL CONDITIONS ONLY)				
ICORE	Current drawn by core	40		μA
IIO	Current drawn by I/O	2		μA

PERIPHERAL CURRENT CONSUMPTION

In addition to the modal current consumption, Table 9 shows the typical current consumption for each of the on-board peripheral blocks. The values were determined with the peripheral clock running at maximum frequency, typical conditions, and no I/O loads. This current is supplied by the 1.8 V power supply.

Table 9. Peripheral Current Consumption

PERIPHERAL	TYPICAL	UNITS
AC97	1.3	mA
UART (Each)	1.0	mA
RTC	0.005	mA
Timers (Each)	0.1	mA
LCD (+I/O)	5.4 (1.0)	mA
MMC	0.6	mA
SCI	23	mA
PWM (each)	< 0.1	mA
BMI-SWI	1.0	mA
BMI-SBus	1.0	mA
SDRAM (+I/O)	1.5 (14.8)	mA
USB (+PLL)	5.6 (3.3)	mA
ACI	0.8	mA

AC Specifications

All signals described in Table 10 relate to transitions after a reference clock signal. The illustration in Figure 7 represents all cases of these sets of measurement parameters.

The reference clock signals in this design are:

- HCLK, internal System Bus clock ('C' in timing data)
- PCLK, Peripheral Bus clock
- SSPCLK, Synchronous Serial Port clock
- UARTCLK, UART Interface clock
- LCDDCLK, LCD Data clock from the LCD Controller
- ACBITCLK, AC97 clock
- SCLK, Synchronous Memory clock.

All signal transitions are measured from the 50% point of the clock to the 50% point of the signal.

For outputs from the LH7A400, t_{OVXXX} (e.g. t_{OVA}) represents the amount of time for the output to become valid from a valid address bus, or rising edge of the peripheral clock. Maximum requirements for t_{OVXXX} are shown in Table 10.

The signal t_{OHXXX} (e.g. t_{OHA}) represents the amount of time the output will be held valid from the valid address bus, or rising edge of the peripheral clock. Minimum requirements for t_{OHXXX} are listed in Table 10.

For Inputs, t_{ISXXX} (e.g. t_{ISD}) represents the amount of time the input signal must be valid after a valid address bus, or rising edge of the peripheral clock. Maximum requirements for t_{ISXXX} are shown in Table 10.

The signal t_{IHXXX} (e.g. t_{IHD}) represents the amount of time the output must be held valid from the valid address bus, or rising edge of the peripheral clock. Minimum requirements are shown in Table 10.

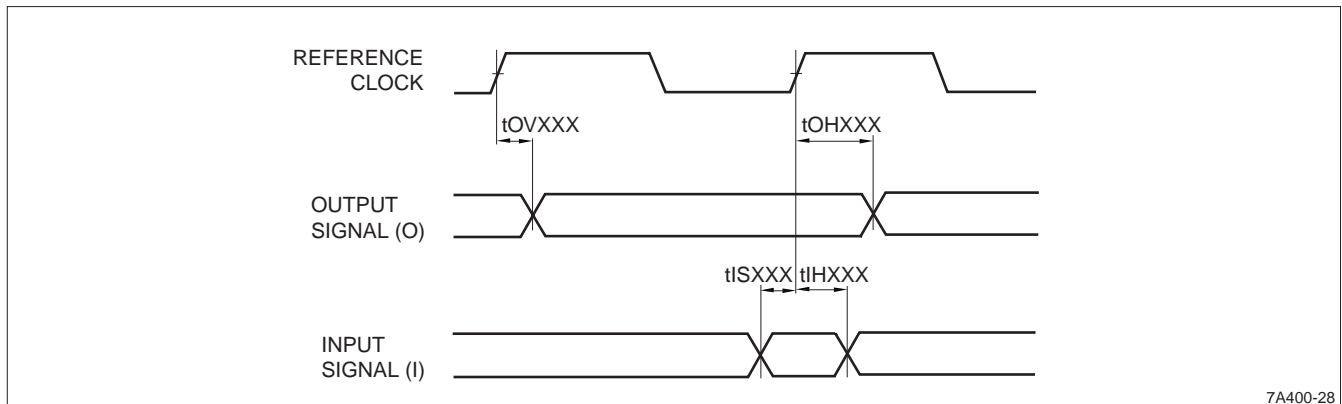

Figure 7. LH7A400 Signal Timing

Table 10. AC Signal Characteristics

SIGNAL	TYPE	LOAD	SYMBOL	MIN.	MAX.	DESCRIPTION
ASYNCHRONOUS MEMORY INTERFACE SIGNALS (+ wait states × C)¹						
A[27:0]	Output	50 pF	tRC	4C ns		Read Cycle Time
	Output	50 pF	tWC	4C ns		Write Cycle Time
	Output	50 pF	tAW	2C – 10 ns		Address Valid to Write Edge
	NA		None	1C ns	1C ns	Wait State Width
D[31:0]	Output	50 pF	tDW	1C – 9 ns		Data Valid to Write Edge
			tDH	1C + 3 ns		Data Hold after Write Edge
	Input		tAA	3C – 20 ns		Address Valid to Data Valid
			tOH	0 ns		Data Output Hold
nCS[3:0]/CS[7:6]	Output	30 pF	tCO	3C – 20 ns		Chip Select Valid to Data Valid (Read)
			tCW		1C – 10 ns	Chip Select Valid to Write edge
			tAS (Write)	1C ns		Address Valid to Chip Select Valid (Address setup time)
			tAS (Read)	0		Address Valid to Chip Select Valid (Address setup time)
nWE[3:0]	Output	30 pF	tWP	1C – 10 ns		Write Pulse Width
			tWHZ	0 ns		Write Edge to High Z on SRAM
nOE	Output	30 pF	tOE		2C – 20 ns	Output Enable Valid to Data Valid
			tOHZ	0 ns		Output Enable invalid to High Z on SRAM
SYNCHRONOUS MEMORY INTERFACE SIGNALS						
SA[13:0]	Output	50 pF	tOVA		7.5 ns	Address Valid
			tOHA	1.5 ns		Address Hold
SA[17:16]/SB[1:0]	Output	50 pF	tOVB		7.5 ns	Bank Select Valid
D[31:0]	Output	50 pF	tOVD	2 ns	7.5 ns	Data Valid
	Input		tISD	2.5 ns		Data Setup
			tIHD	1.5 ns		Data Hold
nCAS	Output	30 pF	tOVCA	2 ns	7.5 ns	CAS Valid
			tOHCA	2 ns		CAS Hold
nRAS	Output	30 pF	tOVRA	2 ns	7.5 ns	RAS Valid
			tOHRA	2 ns		RAS Hold
nSWE	Output	30 pF	tOVSDW	2 ns	7.5 ns	Write Enable Valid
			tOHSDW	2 ns		Write Enable Hold
SCKE[1:0]	Output	30 pF	tOVC	2 ns	7.5 ns	Clock Enable Valid
DQM[3:0]	Output	30 pF	tOVDQ	2 ns	7.5 ns	Data Mask Valid
nSCS[3:0]	Output	30 pF	tOVSC	2 ns	7.5 ns	Synchronous Chip Select Valid
			tOHSC	2 ns		Synchronous Chip Select Hold
PCMCIA INTERFACE SIGNALS (+ wait states × C)¹						
nPCREG	Output	30 pF	tOVDREG		1C	nREG Valid
			tOHDRREG	4C – 5 ns		nREG Hold
D[31:0]	Output	50 pF	tOVD		1C	Data Valid
			tOHD	4C – 5 ns		Data Hold
	Input		tISD		1C - 10 ns	Data Setup Time
			tIHD	4C – 5 ns		Data Hold Time
nPCCE1	Output	30 pF	tOVCE1		1C	Chip Enable 1 Valid
			tOHCE1	4C – 5 ns		Chip Enable 1 Hold
nPCCE2	Output	30 pF	tOVCE2		1C	Chip Enable 2 Valid
			tOHCE2	4C – 5 ns		Chip Enable 2 Hold
nPCOE	Output	30 pF	tOVOE		1C + 1 ns	Output Enable Valid
			tOHOE	3C – 5 ns		Output Enable Hold
nPCWE	Output	30 pF	tOVWE		1C + 1 ns	Write Enable Valid
			tOHWE	3C – 5 ns		Write Enable Hold
PCDIR	Output	30 pF	tOVPCD		1C	Card Direction Valid
			tOHPCD	4C – 5 ns		Card Direction Hold

Table 10. AC Signal Characteristics (Cont'd)

SIGNAL	TYPE	LOAD	SYMBOL	MIN.	MAX.	DESCRIPTION
MMC INTERFACE SIGNALS						
MMCCMD	Output	100 pF	tOVCM		3 ns	MMC Command Valid
			tOHCMD	3 ns		MMC Command Hold
MMCDATA	Output	100 pF	tOVDAT		3 ns	MMC Data Valid
			tOHDAT	3 ns		MMC Data Hold
MMCDATA	Input		tISDAT	5 ns		MMC Data Setup
			tIHDAT	5 ns		MMC Data Hold
MMCCMD	Input		tISCMD	5 ns		MMC Command Setup
			tIHCMD	5 ns		MMC Command Hold
AC97 INTERFACE SIGNALS						
ACOUT/ACSYNC	Output	30 pF	tOVAC97		15 ns	AC97 Output Valid/Sync Valid
			tOHAC97	10 ns		AC97 Output Hold/Sync Hold
ACIN	Input		tISAC97	10 ns		AC97 Input Setup
			tIHAC97	2.5 ns		AC97 Input Hold
ACBITCLK	Input		tACBITCLK	72 ns	90 ns	AC97 Clock Period
SYNCHRONOUS SERIAL PORT (SSP)						
SSPFRM	Input		tISSPFRM	14 ns		SSPFRM Input Valid
SSPTX	Output	50 pF	tOVSSPOUT		14 ns	SSP Transmit Valid
SSPRX	Input		tISSPIN	14 ns		SSP Receive Setup
AUDIO CODEC INTERFACE (ACI)						
ACOUT/ACSYNC	Output	30 pF	tOS	TBD	TBD	ACOUT delay from rising clock edge
			tOH	TBD	TBD	ACOUT Hold
ACIN	Input		tIS	TBD	TBD	ACIN Setup
			tIH	TBD	TBD	ACIN Hold

NOTES:

- 'nC' in the MIN./MAX. columns indicates the number of system clock (HCLK) periods after valid address.
- For Output Drive strength specifications, refer to Table 1.

SMC Waveforms

Figure 8 and Figure 9 show the waveform and timing for an External Asynchronous Memory Write. Note that the deassertion of nWE can precede the deassertion of

nCS by a maximum of one HCLK, or at minimum, can coincide (see Table 10). Figure 10 and Figure 11 show the waveform and timing for an External Asynchronous Memory Read.

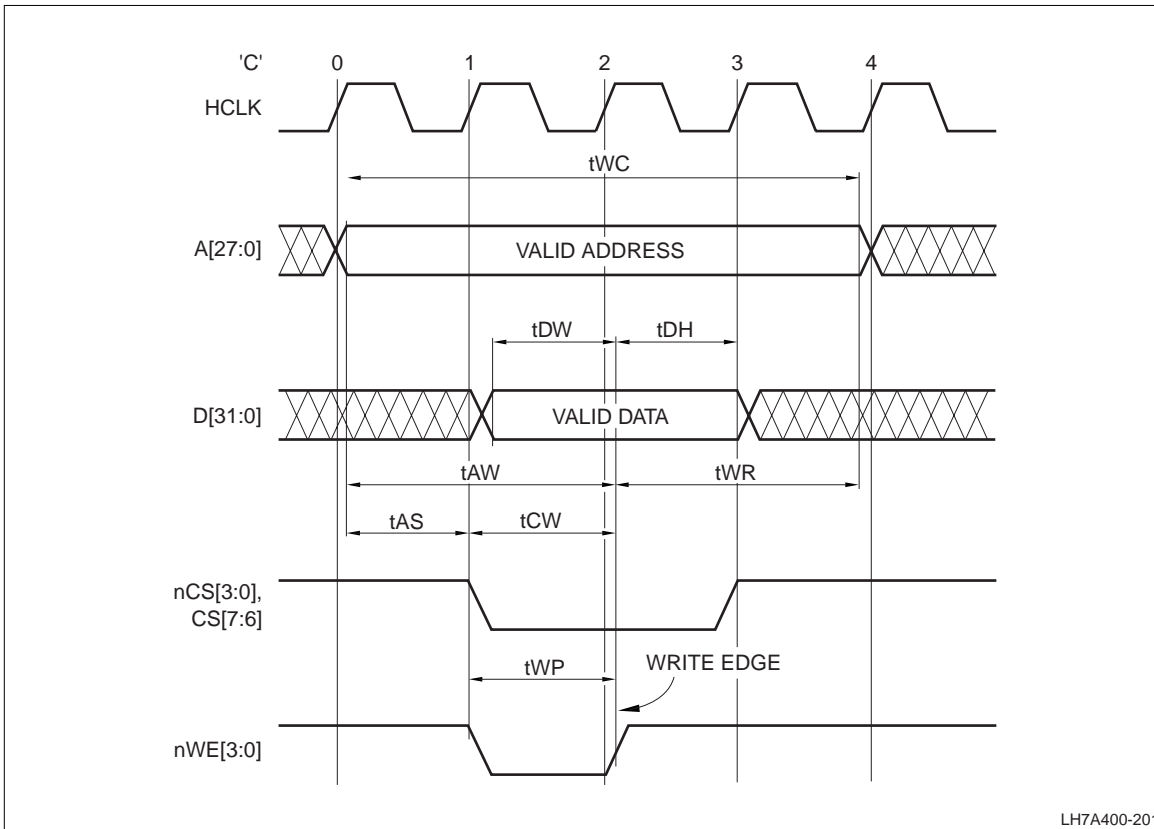

Figure 8. External Asynchronous Memory Write with 0 Wait States (BCRx:WST1 = 0b000)

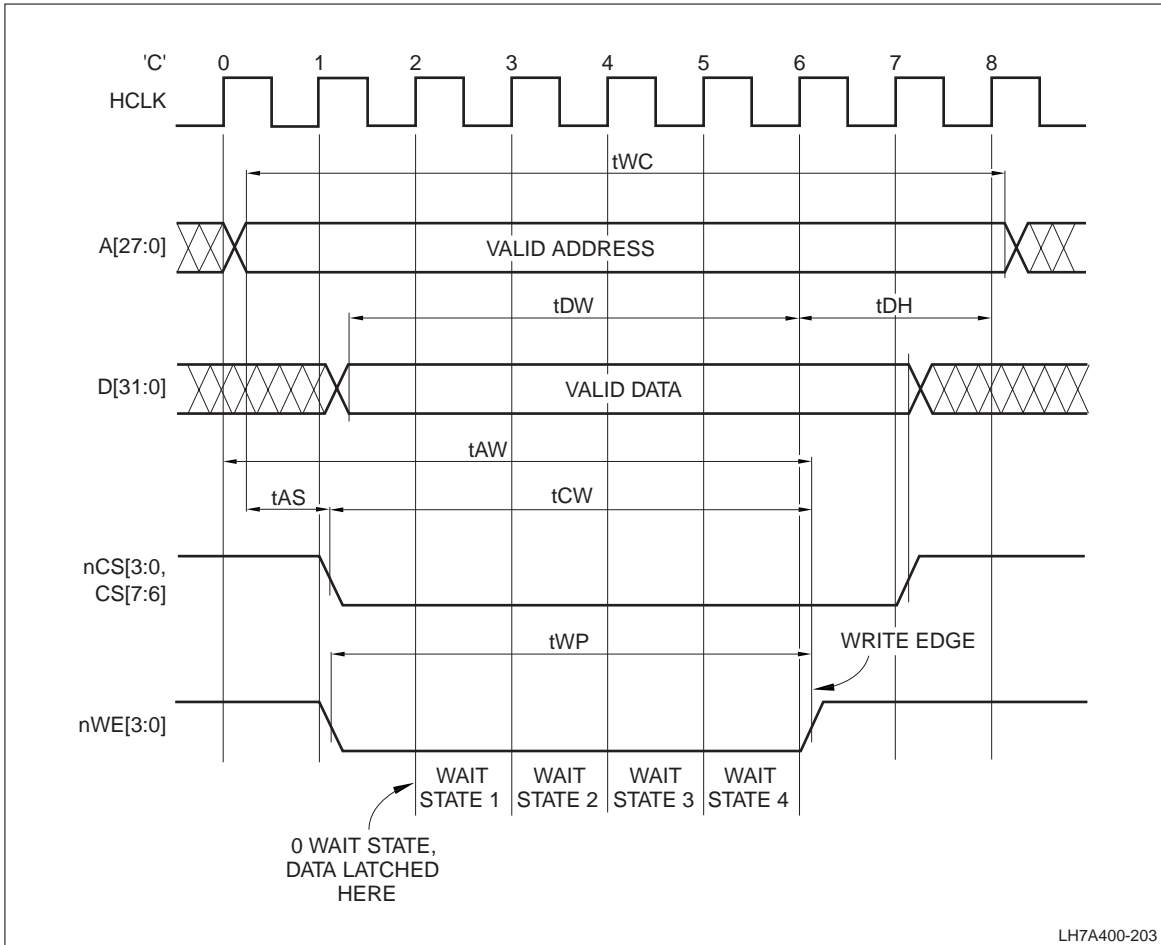

Figure 9. External Asynchronous Memory Write with 4 Wait States (BCRx:WST1 = 0b100)

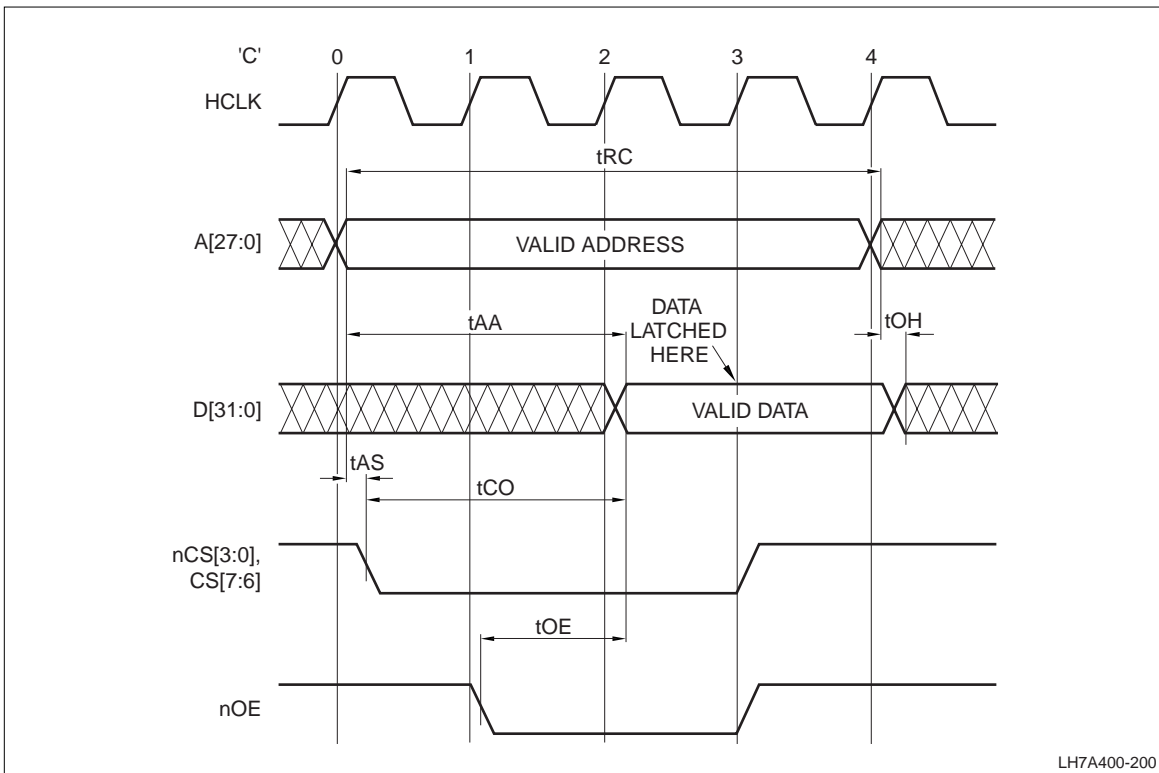

Figure 10. External Asynchronous Memory Read with 0 Wait States (BCRx:WST1 = 0b000)

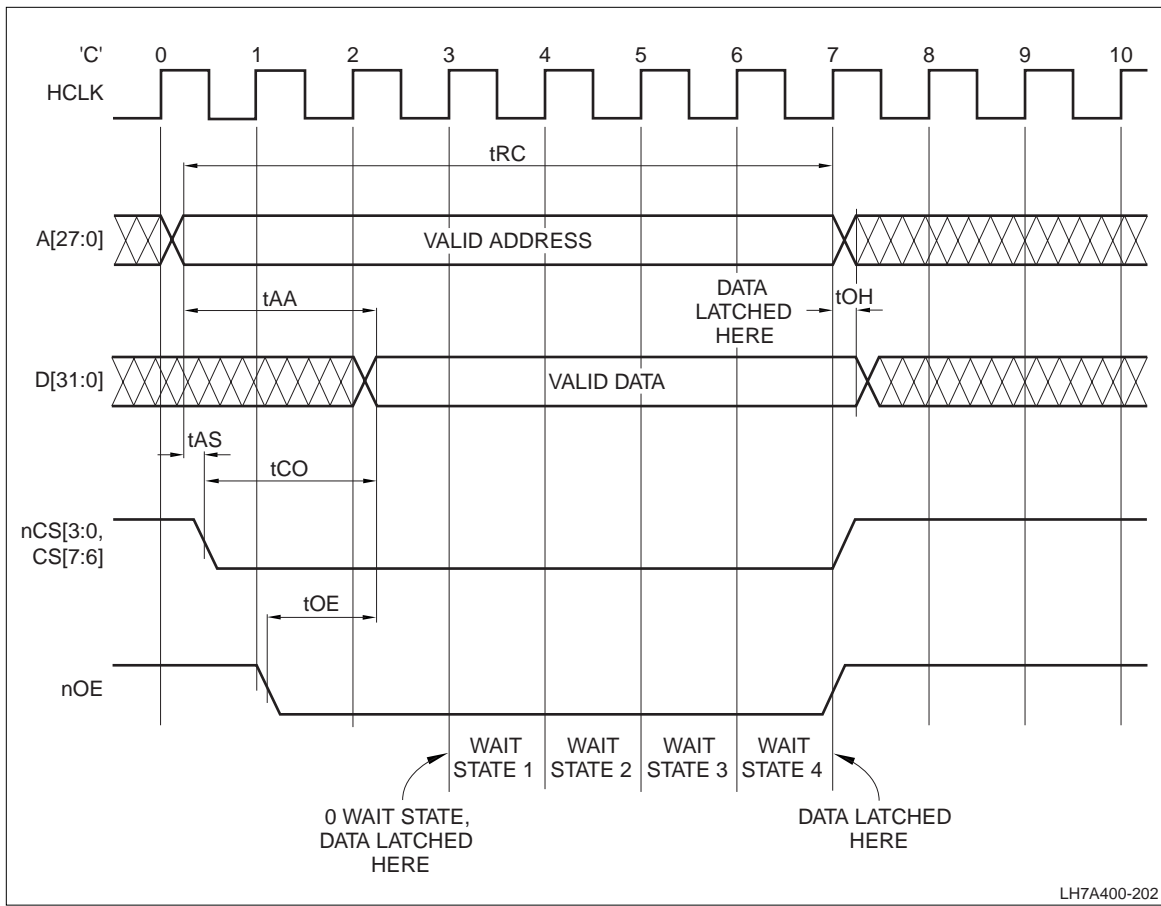

Figure 11. External Asynchronous Memory Read with 4 Wait States (BCRx:WST1 = 0b100)

Synchronous Memory Controller Waveforms

Figure 12 shows the waveform and timing for a Synchronous Burst Read (page already open). Figure 13 shows the waveform and timing for Synchronous memory to Activate a Bank and Write.

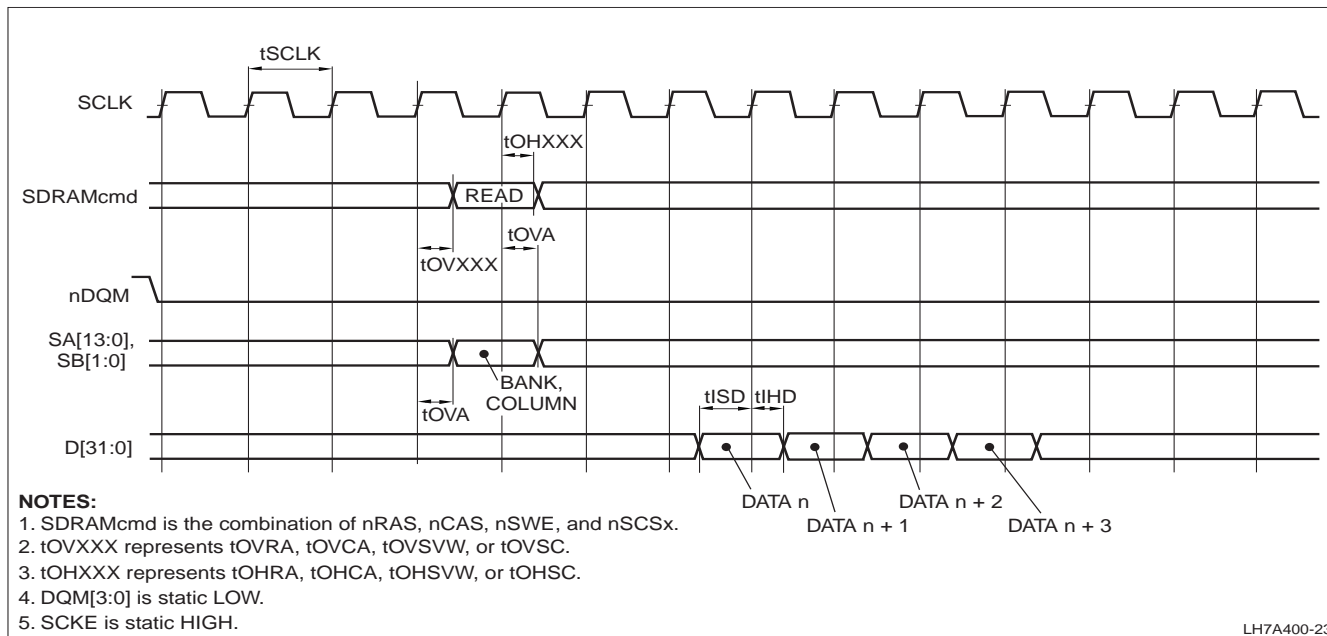

Figure 12. Synchronous Burst Read

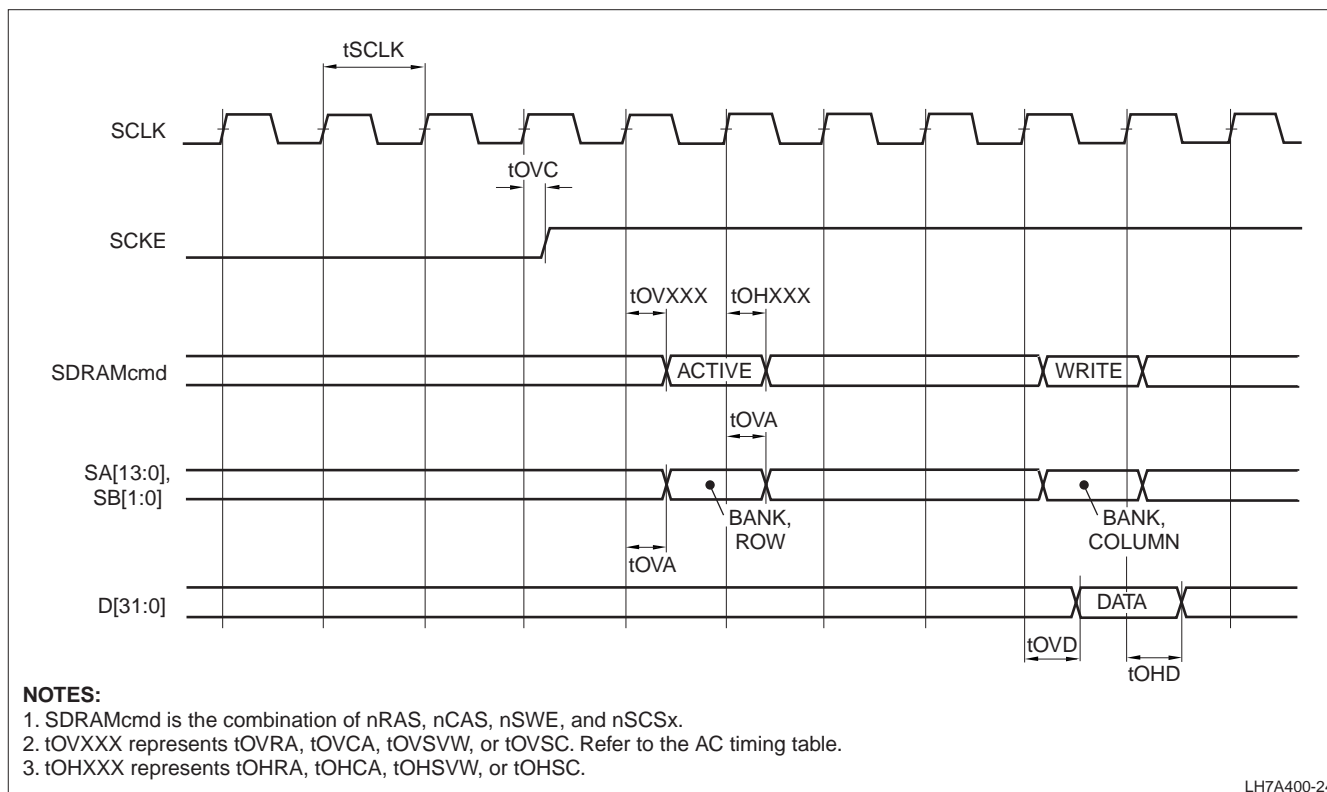
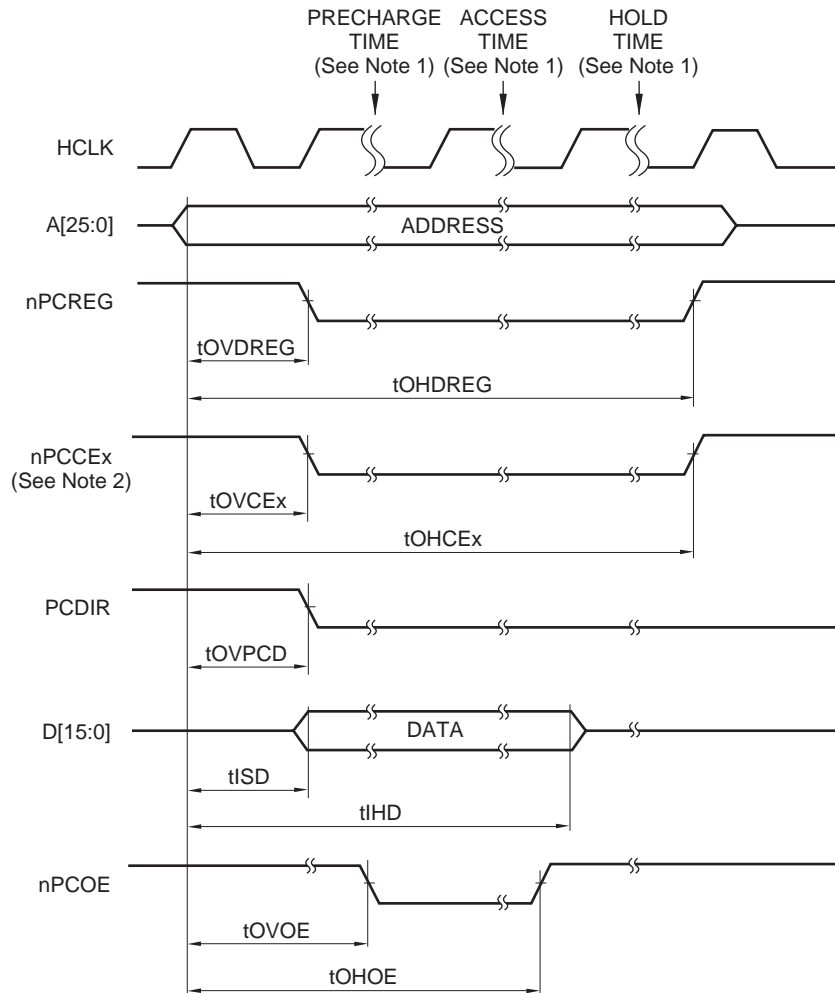

Figure 13. Synchronous Bank Activate and Write

PC Card (PCMCIA) Waveforms

Figure 14 shows the waveforms and timing for a PCMCIA Read Transfer, Figure 15 shows the waveforms and timing for a PCMCIA Write Transfer.



NOTES:

1. Precharge time, access time, and hold time are programmable wait-state times.

2.

nPCCE1	nPCCE2	TRANSFER TYPE
0	0	Common Memory
0	1	Attribute Memory
1	0	I/O
1	1	None

LH7A400-11

Figure 14. PCMCIA Read Transfer

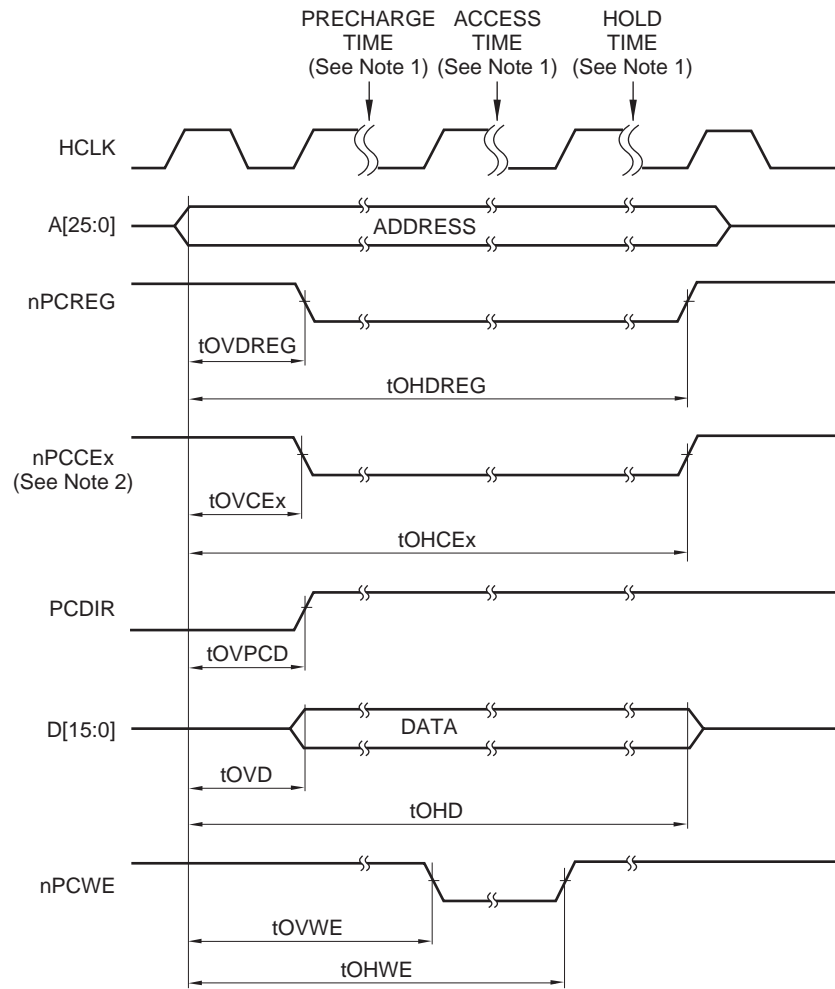

NOTES:

1. Precharge time, access time, and hold time are programmable wait-state times.

2.

nPCCE1	nPCCE2	TRANSFER TYPE
0	0	Common Memory
0	1	Attribute Memory
1	0	I/O
1	1	None

LH7A400-12

Figure 15. PCMCIA Write Transfer

MMC Interface Waveforms

Figure 16 shows the waveforms and timing for an MMC command or data Write, and Figure 17 shows the waveforms and timing for an MMC command or data Read.

AC97 Interface Waveforms

Figure 18 shows the waveforms and timing for the AC97 interface Data Setup and Hold.

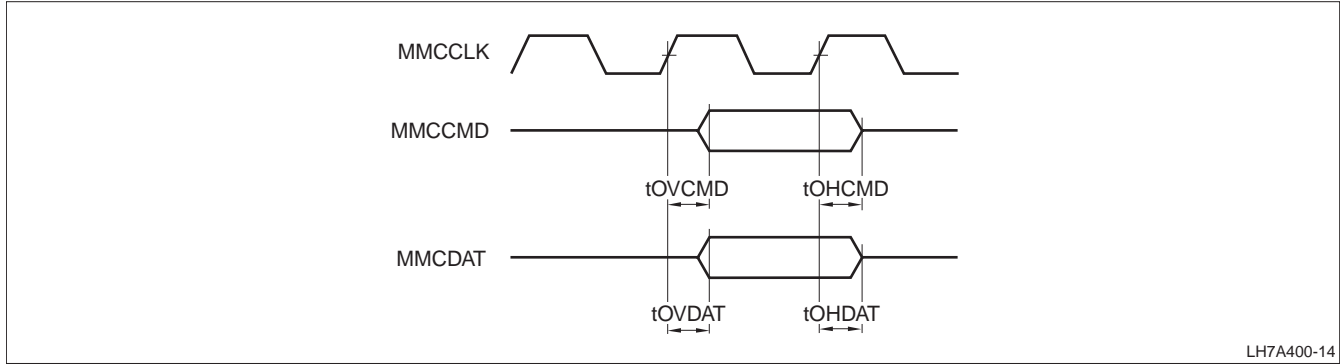

Figure 16. MMC Command/Data Write

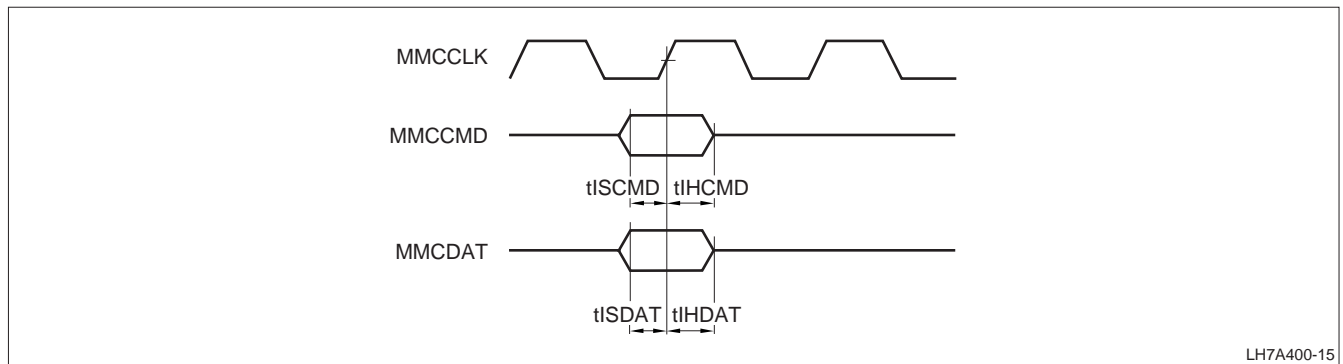

Figure 17. MMC Command/Data Read

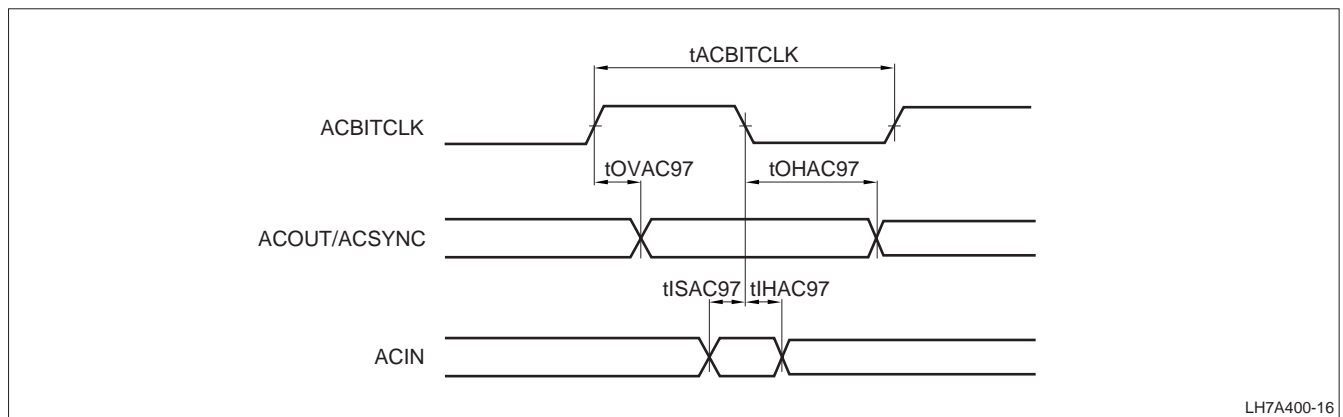

Figure 18. AC97 Data Setup and Hold

Audio Codec Interface Waveforms

Figure 19 and Figure 20 show the timing for the ACI. Transmit data is clocked on the rising edge of ACBITCLK (whether transmitted by the LH7A404 ACI

or by the external codec chip); receive data is clocked on the falling edge. This allows full-speed, full duplex operation.

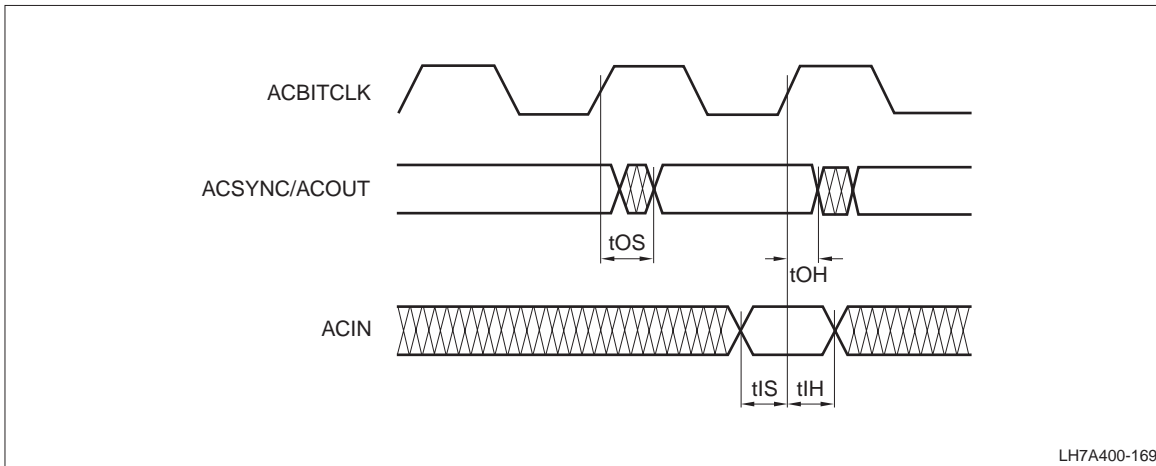

Figure 19. ACI Signal Timing

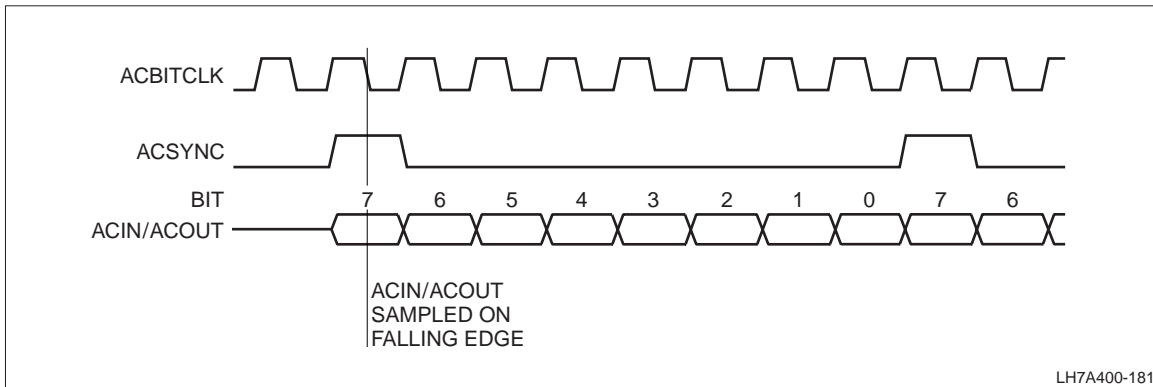

Figure 20. ACI Datastream

Clock and State Controller (CSC) Waveforms

Figure 21 shows the behavior of the LH7A400 when coming out of Reset or Power On. Figure 22 shows external reset timing, and Table 11 gives the timing parameters. Figure 23 depicts signal timing following a Reset. On transition from Standby to Run (including a Cold Boot), the Wakeup pin must not be asserted for 2 seconds after assertion of nPOR to allow time for sampling BATOK and nEXTPWR. The delay prevents a false 'battery good' indication caused by alkaline battery recovery that can immediately follow a battery-low switch off. The battery

sampling takes place on the rising edge of the 1 Hz clock. This clock is derived from the 32.768 kHz oscillator. The WAKEUP pin can be pulsed, but at least one edge must follow the 2 second delay to be recognized. For more information, see the application note "Implementing Auto-Wakeup on the LH7A4xx Series Devices" at www.sharpsma.com.

Figure 24 shows the recommended components for the SHARP LH7A400 32.768 kHz external oscillator circuit. Figure 25 shows the same for the 14.7456 MHz external oscillator circuit. In both figures, the NAND gate represents the internal logic of the chip.

Table 11. Reset AC Timing

PARAMETER	DESCRIPTION	MIN.	MAX.	UNIT
tOSC32	32.768 kHz Oscillator Stabilization Time after Power On*		550	ms
tPORH	nPOR Hold Time after tOSC32	0		ms
tOSC14	14.7456 MHz Oscillator Stabilization Time after Wake UP		4	ms
tPLLL	Phase Locked Loop Lockup Time		250	μs
tURESET/tPWRFL	nURESET/nPWRFL Pulse Width (once sampled LOW)	2		System Clock Cycles

NOTE: *VDDC = VDDCmin

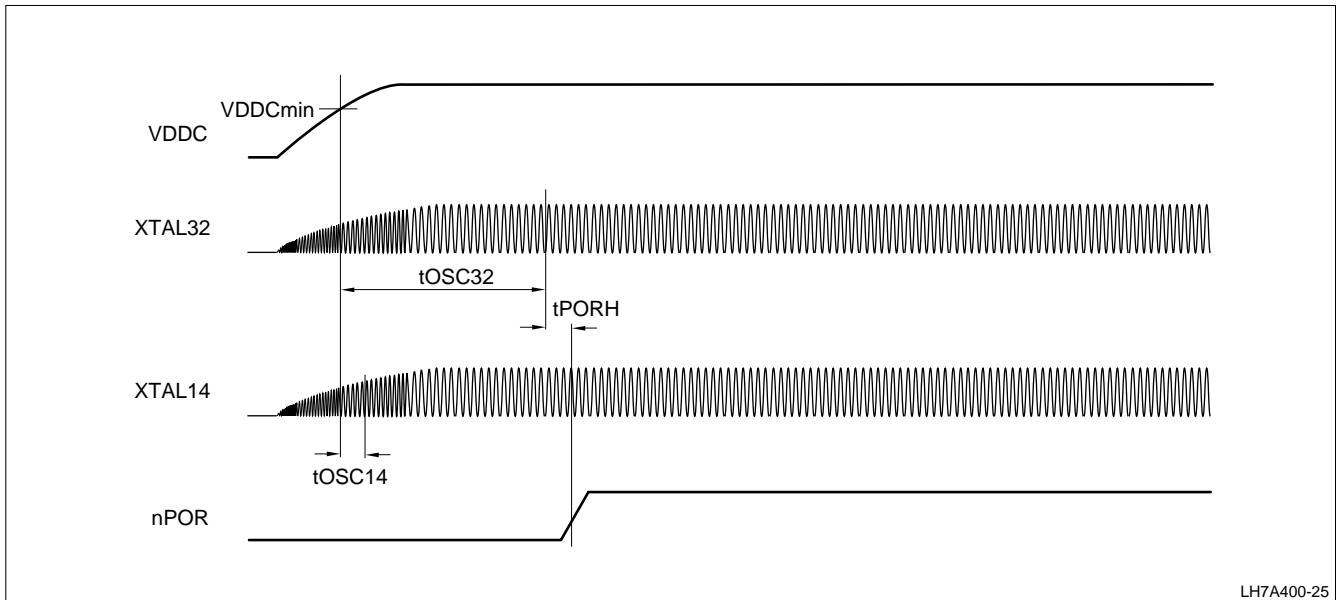

Figure 21. Oscillator Start-up

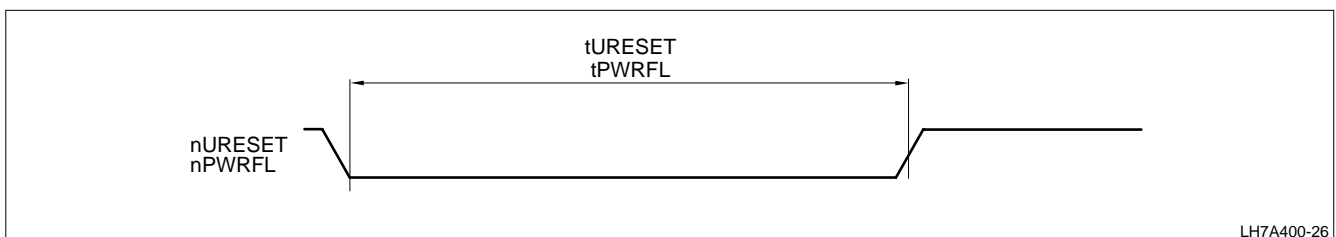

Figure 22. External Reset

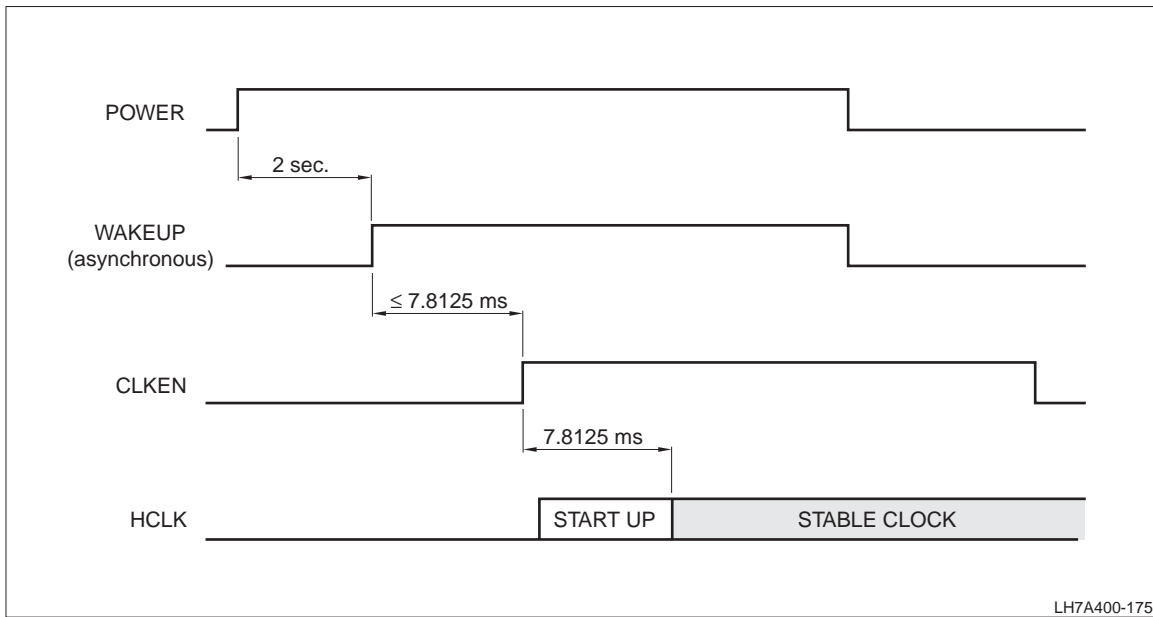

Figure 23. Signal Timing After Reset

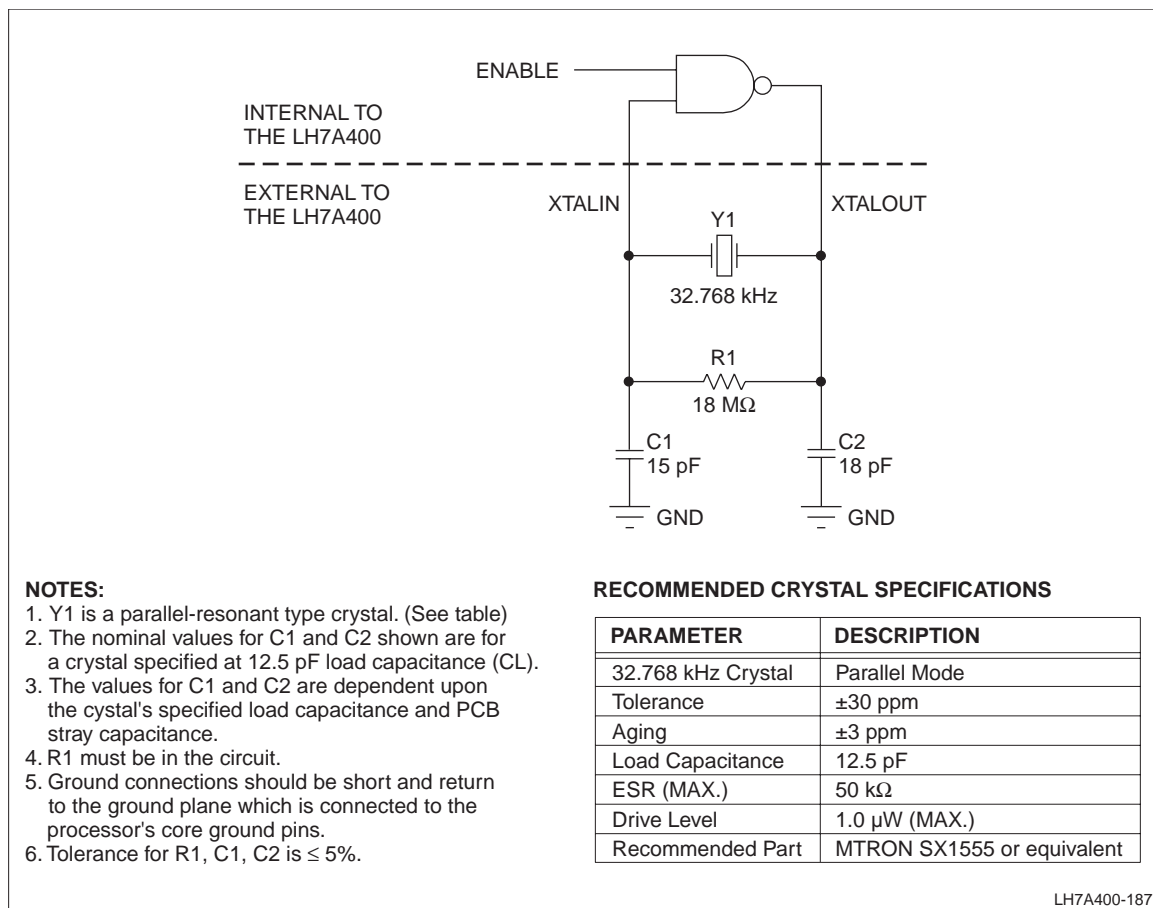

Figure 24. 32.768 kHz External Oscillator Components and Schematic

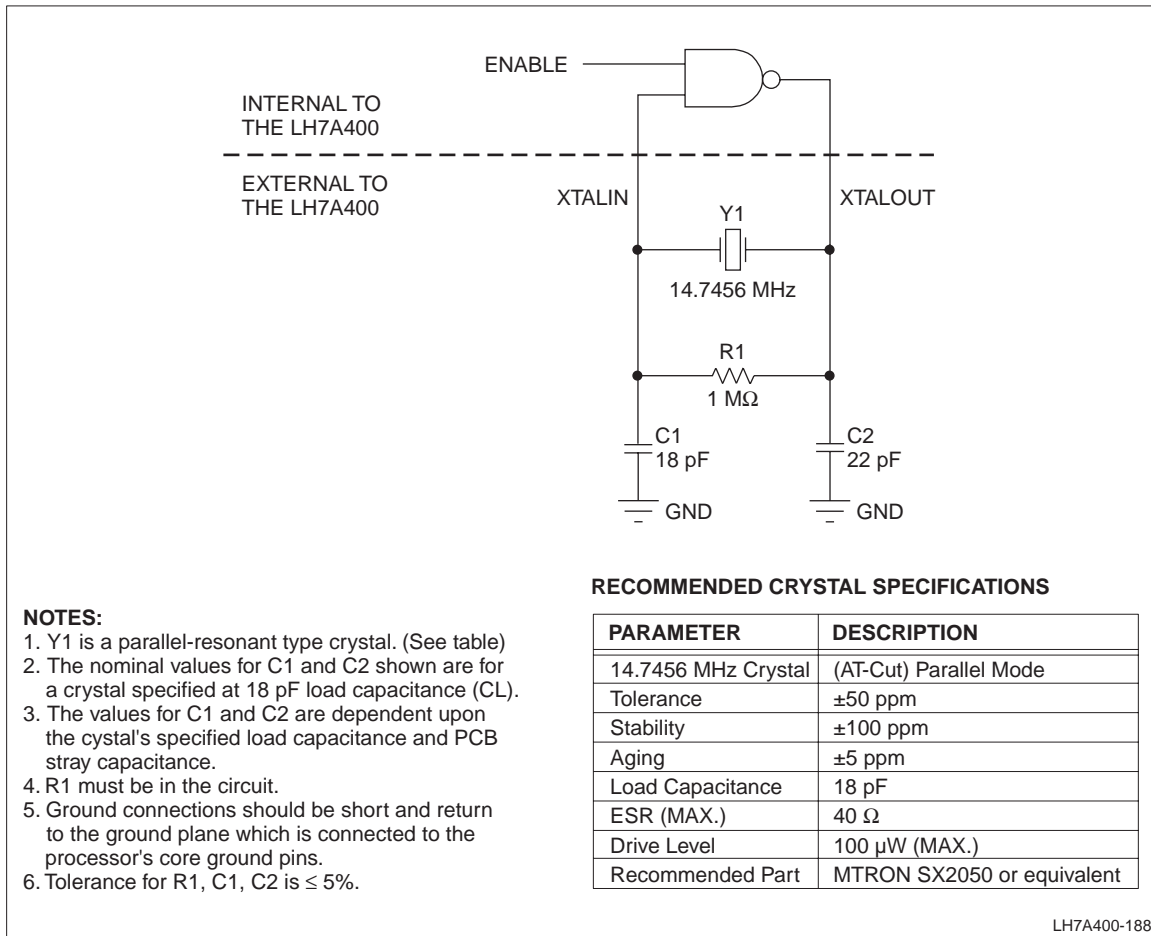

Figure 25. 14.7456 MHz External Oscillator Components and Schematic

Printed Circuit Board Layout Practices

LH7A400 POWER SUPPLY DECOUPLING

The LH7A400 has separate power and ground pins for different internal circuitry sections. The VDD and VSS pins supply power to I/O buffers, while VDDC and VSSC supply power to the core logic, and VDDA/VSSA supply analog power to the PLLs.

Each of the VDD and VDDC pins must be provided with a low impedance path to the corresponding board power supply. Likewise, the VSS, VSSA, and VSSC pins must be provided with a low impedance path to the board ground.

Each power supply must be decoupled to ground using at least one 0.1 μF high frequency capacitor located as close as possible to a VDDx, VSSx pin pair on each of the four sides of the chip. If room on the circuit board allows, add one 0.01 μF high frequency capacitor near each VDDx, VSSx pair on the chip.

To be effective, the capacitor leads and associated circuit board traces connecting to the chip VDDx, VSSx pins must be kept to less than half an inch (12.7 mm) per capacitor lead. There must be one bulk 10 μF capacitor for each power supply placed near one side of the chip.

RECOMMENDED PLL, VDDA, VSSA FILTER

The VDDA pins supply power to the chip PLL circuitry. VSSA is the ground return path for the PLL circuit. SHARP recommends a low-pass filter attached as shown in Figure 26. The values of the inductor and capacitors are not critical. The low-pass filter prevents high frequency noise from adversely affecting the PLL circuits. The distance from the IC pin to the high frequency capacitor should be as short as possible.

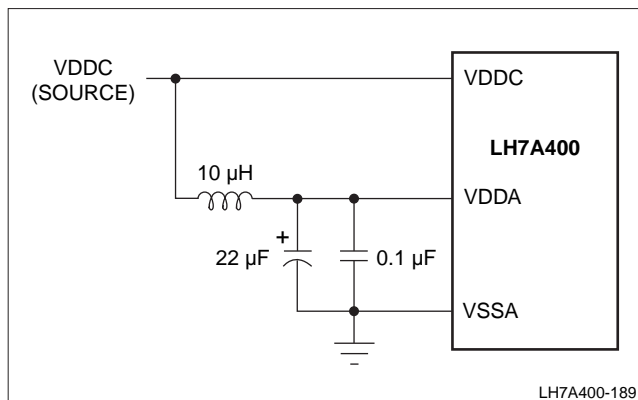

Figure 26. VDDA, VSSA Filter Circuit

UNUSED INPUT SIGNAL CONDITIONING

Floating input signals can cause excessive power consumption. Unused inputs without internal pull-up or pull-down resistors should be pulled up or down externally, to tie the signal to its inactive state.

Some GPIO signals default to inputs. If the pins that carry these signals are unused, software can program these signals as outputs, eliminating the need for pull-ups or pull-downs. Power consumption may be higher than expected until software completes programming the GPIO. Some LH7A400 inputs have internal pull-ups or pull-downs. If unused, these inputs do not require external conditioning.

OTHER CIRCUIT BOARD LAYOUT PRACTICES

All outputs have fast rise and fall times. Printed circuit trace interconnection length must therefore be reduced to minimize overshoot, undershoot and reflections caused by transmission line effects of these fast output switching times. This recommendation particularly applies to the address and data buses.

When considering capacitance, calculations must consider all device loads and capacitances due to the circuit board traces. Capacitance due to the traces will depend upon a number of factors, including the trace width, dielectric material the circuit board is made from and proximity to ground and power planes.

Attention to power supply decoupling and printed circuit board layout becomes more critical in systems with higher capacitive loads. As these capacitive loads increase, transient currents in the power supply and ground return paths also increase.

PACKAGE SPECIFICATIONS

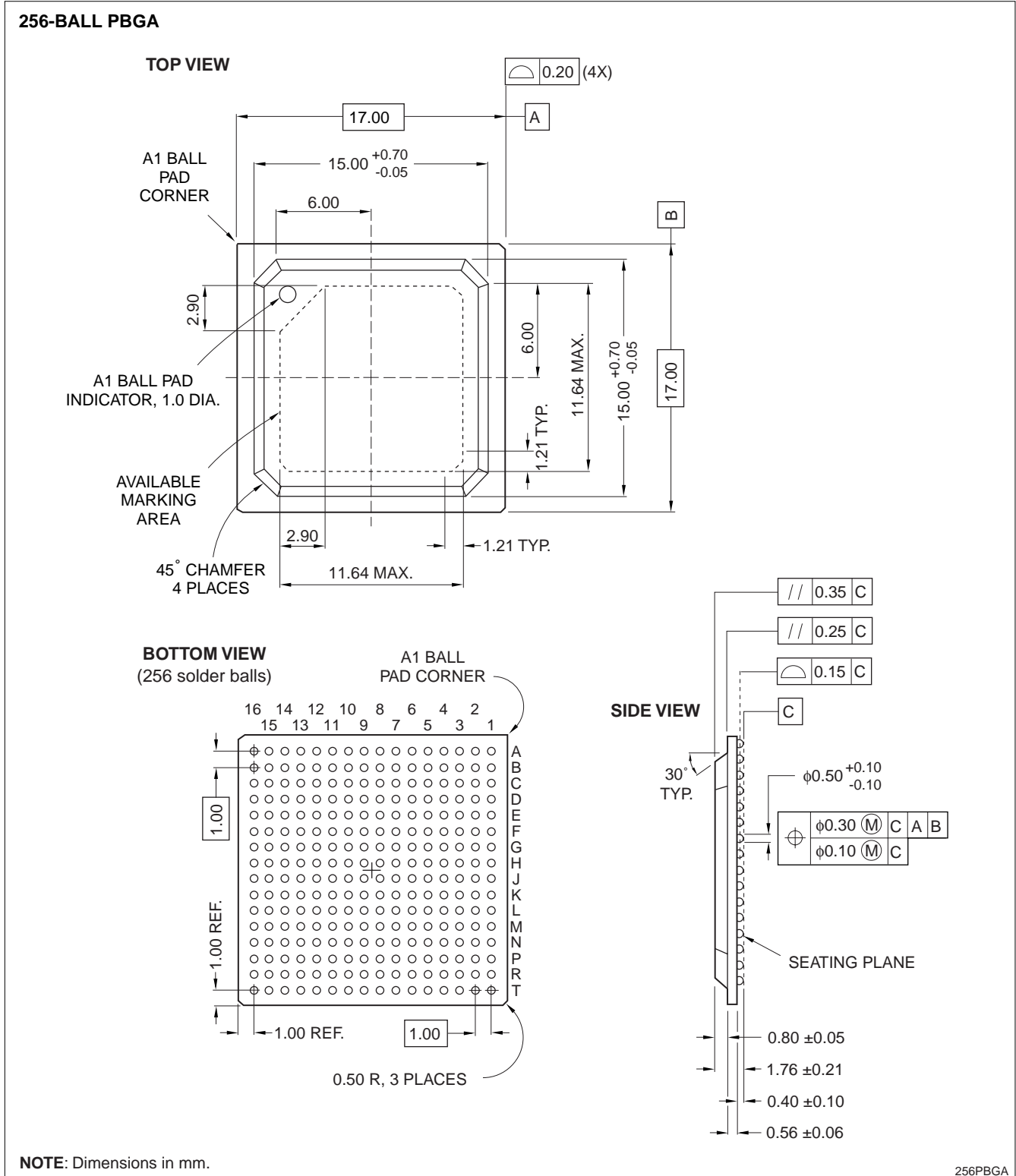

Figure 27. 256-Ball PBGA Package Specification

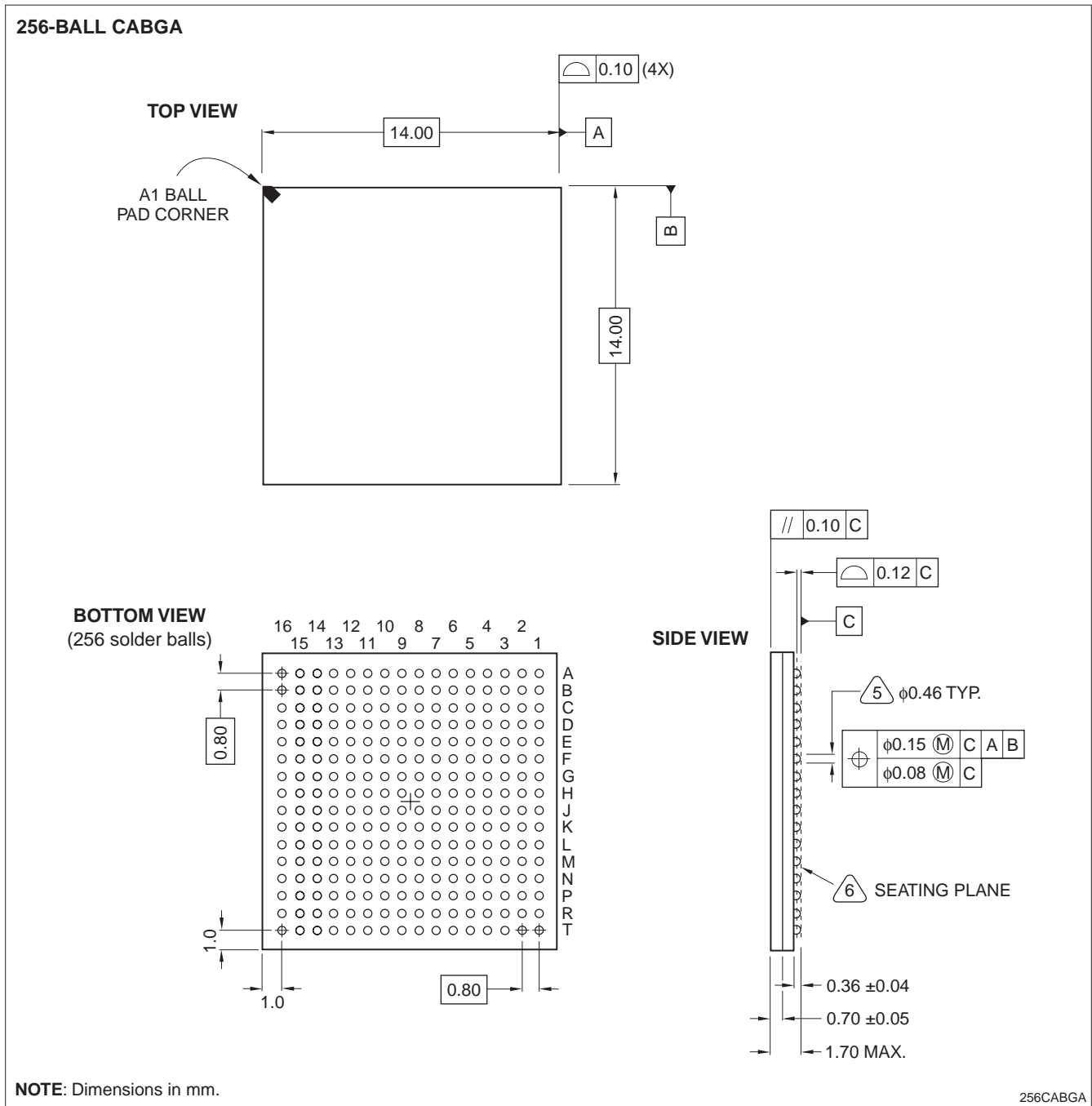

Figure 28. 256-Ball CABGA Package Specification

CONTENT REVISIONS

This document contains the following changes to content, causing it to differ from previous versions.

Table 12. Record of Revisions

DATE	PAGE NO.	PARAGRAPH OR ILLUSTRATION	SUMMARY OF CHANGES
8-19-2003	1	Features	256-ball CABGA package added
	3-11	Table 1	CABGA Pins added; VDDA1/VDDA2 combined to VDDA; VSSA1/VSSA2 combined to VSSA
	12	Table 3	Signal ordering corrected
	12-18	Table 4	Table title added to differentiate between PBGA and CABGA packages
	18-24	Table 5	CABGA numerical pin list table added
	39	Figure 7 and Figure 8	'CSx' added to figures
	41-42	Figures 11 and 12	PCDIR signal corrected in PCMCIA timing diagrams
	44	Table 10 and Figure 16	tOSC14 added to both table and figure; XTAL14 added to figure; tPLLL added to table
	45-47	Figures 19-21 and Printed Circuit Board Layout Practices	Figures and text added
49	Figure 23	Figure added for CABGA package	
11-15-03	1	Text	Corrected minor text errors; added separate Commercial and Industrial temperature specification.
	2	Figure 1	Updated to show ALI Interface
	34	'Recommended Operating Conditions'	Broke out "Commercial" and "Industrial" speed ranges.
	39	Table 10	Minor corrections to type.
	39	Table 10	Added ACI timing.
	54	Figure 27	PBGA package drawing added.
6-21-04	11	Table 1	Changed names of BOOTWIDTH0 and BOOTWIDTH1 to WIDTH0 and WIDTH1 for consistency with other Sharp SoCs.
	53	Figure 26; text	Revised text and drawing to indicate that the VSSA pin must be grounded
	50	Table 11	Added table.
12-07-04	ALL		Rolled revision to Version 1.0
	1	Text	Run current corrected to 125 mA and Halt to 25 mA
	34	Table 7, Figure 6	Added table and accompanying graph for speed/temperature/voltage
	36	'DC Specifications'	Added IRUN, IHALT, and ISTANDBY; corrected IIN.
	37	Table 8	Corrected values in Table 8.
	39	Table 10	Changed Asynchronous Memory timing to match SRAM datasheet parameter naming conventions. Corrected Synchronous Memory times; added synchronous memory Address Hold time.
	41-44	Figure 8 - Figure 11	Changed Asynchronous Memory timing diagrams to match renamed parameters.
51	Text and Figure 23	Clarification made to timing for cold boot power-on sequence.	
12-13-04	36	'DC Specifications'	Added IIN without pullup resistors.

SPECIFICATIONS ARE SUBJECT TO CHANGE WITHOUT NOTICE.

Suggested applications (if any) are for standard use; See Important Restrictions for limitations on special applications. See Limited Warranty for SHARP's product warranty. The Limited Warranty is in lieu, and exclusive of, all other warranties, express or implied. ALL EXPRESS AND IMPLIED WARRANTIES, INCLUDING THE WARRANTIES OF MERCHANTABILITY, FITNESS FOR USE AND FITNESS FOR A PARTICULAR PURPOSE, ARE SPECIFICALLY EXCLUDED. In no event will SHARP be liable, or in any way responsible, for any incidental or consequential economic or property damage.

SHARP®**NORTH AMERICA**

SHARP Microelectronics of the Americas
5700 NW Pacific Rim Blvd.
Camas, WA 98607, U.S.A.
Phone: (1) 360-834-2500
Fax: (1) 360-834-8903
www.sharpsma.com

EUROPE

SHARP Microelectronics Europe
Division of Sharp Electronics (Europe) GmbH
Sonninstrasse 3
20097 Hamburg, Germany
Phone: (49) 40-2376-2286
Fax: (49) 40-2376-2232
www.sharpsme.com

JAPAN

SHARP Corporation
Electronic Components & Devices
22-22 Nagaike-cho, Abeno-Ku
Osaka 545-8522, Japan
Phone: (81) 6-6621-1221
Fax: (81) 6117-725300/6117-725301
www.sharp-world.com

TAIWAN

SHARP Electronic Components
(Taiwan) Corporation
8F-A, No. 16, Sec. 4, Nanking E. Rd.
Taipei, Taiwan, Republic of China
Phone: (886) 2-2577-7341
Fax: (886) 2-2577-7326/2-2577-7328

SINGAPORE

SHARP Electronics (Singapore) PTE., Ltd.
438A, Alexandra Road, #05-01/02
Alexandra Technopark,
Singapore 119967
Phone: (65) 271-3566
Fax: (65) 271-3855

KOREA

SHARP Electronic Components
(Korea) Corporation
RM 501 Geosung B/D, 541
Dohwa-dong, Mapo-ku
Seoul 121-701, Korea
Phone: (82) 2-711-5813 ~ 8
Fax: (82) 2-711-5819

CHINA

SHARP Microelectronics of China
(Shanghai) Co., Ltd.
28 Xin Jin Qiao Road King Tower 16F
Pudong Shanghai, 201206 P.R. China
Phone: (86) 21-5854-7710/21-5834-6056
Fax: (86) 21-5854-4340/21-5834-6057
Head Office:
No. 360, Bashen Road,
Xin Development Bldg. 22
Waigaoqiao Free Trade Zone Shanghai
200131 P.R. China
Email: smc@china.global.sharp.co.jp

HONG KONG

SHARP-ROXY (Hong Kong) Ltd.
3rd Business Division,
17/F, Admiralty Centre, Tower 1
18 Harcourt Road, Hong Kong
Phone: (852) 28229311
Fax: (852) 28660779
www.sharp.com.hk
Shenzhen Representative Office:
Room 13B1, Tower C,
Electronics Science & Technology Building
Shen Nan Zhong Road
Shenzhen, P.R. China
Phone: (86) 755-3273731
Fax: (86) 755-3273735

Looking for pricing, stock, or lifecycle information?

Click below to explore more details on WIN SOURCE:

 [View LH7A400N0G000B5 on WIN SOURCE](#)

 [Sharp Microelectronics](#) Information

Optimize Your Supply Chain with WIN SOURCE Solutions

-  Global Sourcing Solution
-  Obsolete Management
-  Cost Control Management
-  Shortage Management
-  Alternative Solution
-  Excess Inventory Management