

Power driver IC for CD changer

BD7960FM

BD7960FM is a 6-channel driver (4-channel BTL driver + 2-channel loading driver) for car CD changer. This IC integrates 1-channel operational amplifier for various purposes. The size reduction of the set is achieved by integrating loading driver and actuator driver into a single chip.

●Applications

CD changer

●Features

- 1) This circuit is a 6-channel driver IC consisting of four BTL drivers and two loading drivers.
- 2) Two wide dynamic range loading drivers of MOS output ($R_{ON}=1.0\Omega$).
- 3) The circuit is provided with loading driver voltage setting terminals.
- 4) A general Opamp and Pre Opamp are built in.
- 5) The circuit has a mute switch.
- 6) The circuit has a reset terminal.
- 7) A thermal shutdown circuit is built in.
- 8) Since HSOP-M36 power package is used, the set requires a reduced space.

●Absolute maximum ratings (Ta=25°C)

Parameter	Symbol	Limits	Unit
Supply voltage	V _{cc}	15	V
Power dissipation	P _d	2.2*	W
Operating temperature range	T _{opr}	-40~+85	°C
Storage temperature range	T _{stg}	-55~+150	°C

* Reduced by 17.6mW for each increase in Ta of 1°C over 25°C, on less than 3% (percentage occupied by copper foil), 70mm×70mm, t=1.6mm, glass epoxy mounting.

●Recommended operating conditions (Ta=25°C)

Parameter	Symbol	Min.	Typ.	Max.	Unit
Supply voltage 1	V _{cc1}	4.5	8.0	14.0	V
Supply voltage 2	V _{cc2}	4.5	8.0	V _{cc1}	V

Optical disc ICs

●Block diagram

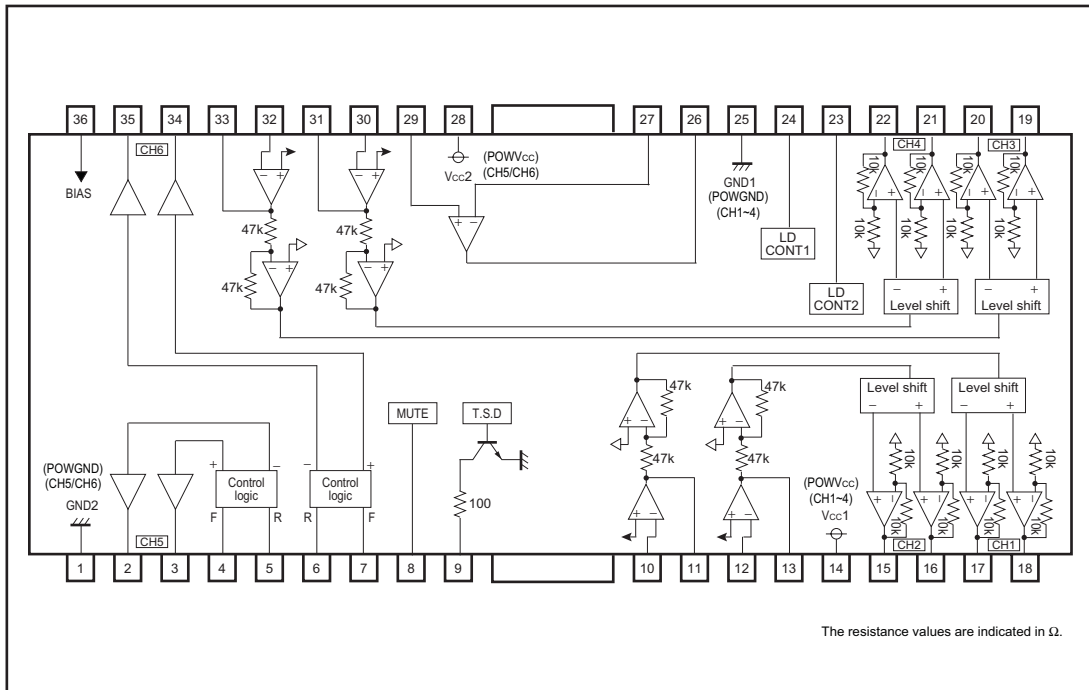

●Pin descriptions

Pin No.	Pin name	Function	Pin No.	Pin name	Function
1	GND2	POW GND (loading driver unit)	19	OUT3+	BTL driver (CH3) output +
2	OUT5-	Loading driver (CH5) output -	20	OUT3-	BTL driver (CH3) output -
3	OUT5+	Loading driver (CH5) output +	21	OUT4+	BTL driver (CH4) output +
4	IN5FWD	Loading driver (CH5) FWD input	22	OUT4-	BTL driver (CH4) output -
5	IN5REV	Loading driver (CH5) REV input	23	LDCONT2	Loading driver (CH6) voltage setting terminal
6	IN6REV	Loading driver (CH6) REV input	24	LDCONT1	Loading driver (CH5) voltage setting terminal
7	IN6FWD	Loading driver (CH6) FWD input	25	GND1	POW GND (BTL driver unit)
8	MUTE	BTL driver mute terminal	26	OPOUT	Opamp output
9	RESET	Reset output terminal	27	OPIN-	Opamp negative input
10	OPIN1-	CH1 opamp negative input	28	Vcc2	Supply voltage (loading driver unit)
11	OP1OUT	CH1 opamp output	29	OPIN+	Opamp positive input
12	OPIN2-	CH2 opamp negative input	30	OPIN4-	CH4 opamp negative input
13	OP2OUT	CH2 opamp output	31	OP4OUT	CH4 opamp output
14	Vcc1	Supply voltage (BTL driver unit)	32	OPIN3-	CH3 opamp negative input
15	OUT2-	BTL driver (CH2) output -	33	OP3OUT	CH3 opamp output
16	OUT2+	BTL driver (CH2) output +	34	OUT6+	Loading driver (CH6) output +
17	OUT1-	BTL driver (CH1) output -	35	OUT6-	Loading driver (CH6) output -
18	OUT1+	BTL driver (CH1) output +	36	BIAS	BIAS terminal

* Symbol of + and - (output of BTL driver) means polarity to opamp output pin.
For example if Opamp output voltage is H, BTL driver +output is H, -output is L

Optical disc ICs

● Input output circuit

BIAS		OUT1+/OUT1-/OUT2+/OUT2- OUT3+/OUT3-/OUT4+/OUT4-	
IN5FWD/IN5REV IN6FWD/IN6REV	OUT5+/OUT5- OUT6+/OUT6-	LDCONT1/LDCONT2	
OPIN1-/OPIN2-/OPIN3- OPIN4-/OPIN-/OPIN+		OP1OUT/OP2OUT/OP3OUT OP4OUT/OPOUT	
MUTE		RESET	

Optical disc ICs

● Electrical characteristics

(unless otherwise noted, $T_a=25^{\circ}\text{C}$, V_{CC1} , $V_{CC2}=8\text{V}$, $\text{BIAS}=2.5\text{V}$, $R_L=8\Omega$)

Parameter	Symbol	Min.	Typ.	Max.	Unit	Conditions
Quiescent current (V_{CC1})	I_{CC1}	15	25	35	mA	Under no load
Quiescent current (V_{CC2})	I_{CC2}	–	3	6	mA	Under no load
〈 BTL driver CH1 to CH4 〉						
Output offset voltage	V_{OFS}	–40	0	+70	mV	
Max. output amplitude	V_{OM}	5.4	6.0	–	V	
Closed circuit voltage gain	G_{VC}	10	12	14	dB	$V_{IN}=\text{BIAS}\pm 0.5\text{V}$ Opamp : Buffer
〈 Loading driver CH5 and CH6 〉						
Output offset voltage	V_{OFSL}	–35	0	+35	mV	When brake is applied
Output saturation voltage H	V_{OLH}	–	0.38	0.70	V	$I_o=500\text{mA}$
Output saturation voltage L	V_{OLL}	–	0.12	0.25	V	$I_o=500\text{mA}$
Voltage gain	G_{VLD}	4.0	6.0	8.0	dB	$\text{LDCONT}=1\text{V}$
〈 Opamp and Pre Opamp CH1 to CH4 〉						
Input offset voltage	V_{OPOFS}	–5	0	+5	mV	
Common mode input voltage range	V_{OPICM}	0.3	–	$V_{CC}-1.2$	V	
Maximum output source current	I_{SOURCE}	500	800	–	μA	
Maximum output sink current	I_{SINK}	2	–	–	mA	
〈 Reset 〉						
Output sat voltage	V_{ORST}	–	0.3	0.5	V	
Output leak current	I_{REAK}	–	0	10	μA	

© The product is not designed for protection against radioactive rays.

Optical disc ICs

● Measurement circuits

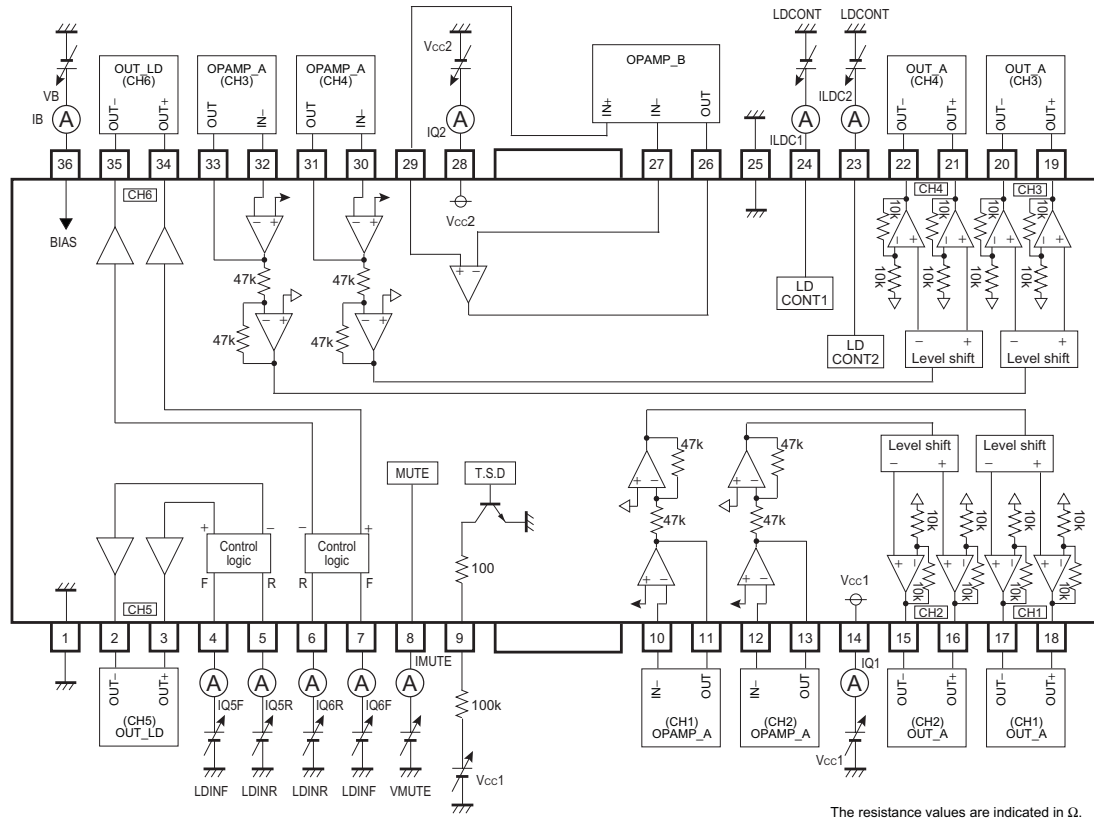

Fig.1

Optical disc ICs

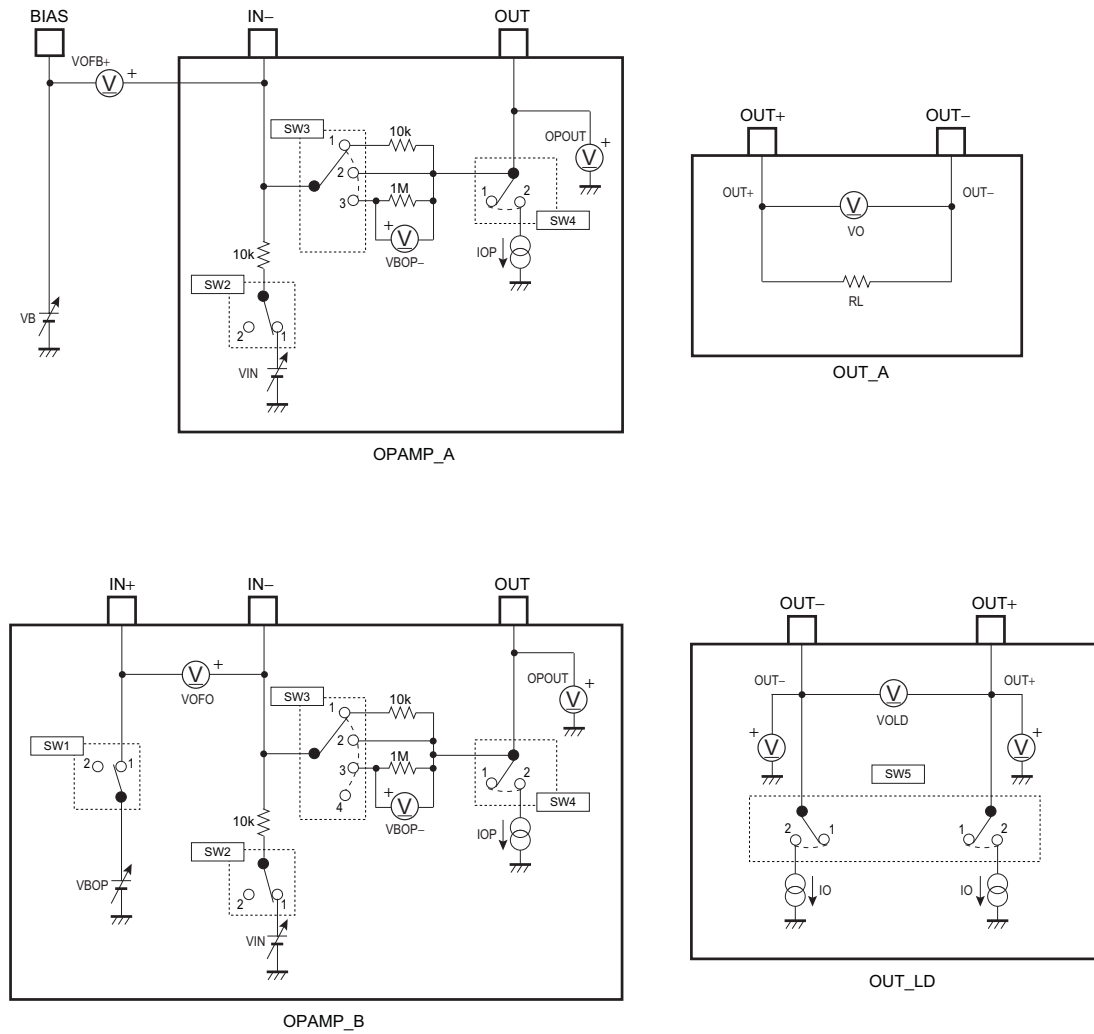

Fig.2

Optical disc ICs

● Switch table for measuring circuit diagrams

(unless otherwise noted, $T_a=25^\circ\text{C}$, $V_{CC1}, V_{CC2}=8\text{V}$, $\text{BIAS}=2.5\text{V}$, $\text{VBOP}=2.5\text{V}$, $\text{RL}=8\Omega$
 unless otherwise noted, the switch 1 is used.)

Parameter	Symbol	Switching					Conditions	Measurement circuit
		1	2	3	4	5		
Quiescent current	I_{CC1}	2	2				$\text{LDINF}=\text{LDINR}=0\text{V}$, $\text{RL}=\infty$, $I_{CC1}=I_{Q1}$	Fig.1, 2
Quiescent current (BTL MUTE)	I_{CC2}	2	2				$\text{LDINF}=\text{LDINR}=0\text{V}$, $\text{RL}=\infty$, $I_{CC2}=I_{Q2}$	Fig.1, 2
〈 BTLdriver CH1 to CH4 〉								
Output offset voltage	V_{OFS}		2				$V_{IN}=\text{VB}$, $V_{OFS}=\text{VO}$	Fig.1, 2
Max. output amplitude	V_{OM}						$V_{IN}=\text{GND}$, $V_{OM}=\text{VO}$	Fig.1, 2
Closed circuit voltage gain (CH1 to CH4)	G_{VC}						$V_{IN}=\text{VB}+0.5\text{V}$, $G_{VC}=20\log(\text{VO}/0.5)$	Fig.1, 2
〈 Loading driver CH5 and CH6 〉								
Output offset voltage	V_{OFSL}						$\text{LDINF}=\text{LDINR}=-5\text{V}$, $V_{OFSL}=\text{VOLD}$	Fig.1, 2
Output saturation voltage H	V_{OLH}					2	$\text{LDINF}=5\text{V}$, $\text{LDINR}=0\text{V}$, $I_o=500\text{mA}$, $\text{VOLH}=\text{V}_{CC}-\text{OUT}+$ $\text{LDINF}=0\text{V}$, $\text{LDINR}=-5\text{V}$, $I_o=500\text{mA}$, $\text{VOLH}=\text{V}_{CC}-\text{OUT}-$	Fig.1, 2
Output saturation voltage L	V_{OLL}					2	$\text{LDINF}=5\text{V}$, $\text{LDINR}=0\text{V}$, $I_o=-500\text{mA}$, $\text{VOLL}=\text{OUT}-$ $\text{LDINF}=0\text{V}$, $\text{LDINR}=-5\text{V}$, $I_o=-500\text{mA}$, $\text{VOLL}=\text{OUT}+$	Fig.1, 2
Voltage gain (Loading)	G_{VLD}						$\text{LDCONT}=1$, $G_{VLD}=20\log(\text{VOLD}/1\text{V})$	Fig.1, 2
〈 Opamp and Pre Opamp CH1 to CH4 〉								
Input offset voltage	V_{OPOFS}		2				$V_{OPOFS}=\text{VOFB}+$	Fig.1, 2
Common mode input voltage range	V_{OPICM}			2			$V_{OPICM}=\text{Between } V_{IN} \text{ to } \text{OPOUT}$	Fig.1, 2
Max. output source current	I_{SOURCE}		2	2	2			Fig.1, 2
Max. output sink current	I_{SINK}		2	2	2			Fig.1, 2
〈 Reset 〉								
Output sat voltage	V_{ORST}						CHIP $T_a=T.S.D$	Fig.1, 2
Output leak current	I_{REAK}							Fig.1, 2

Optical disc ICs

● Application example

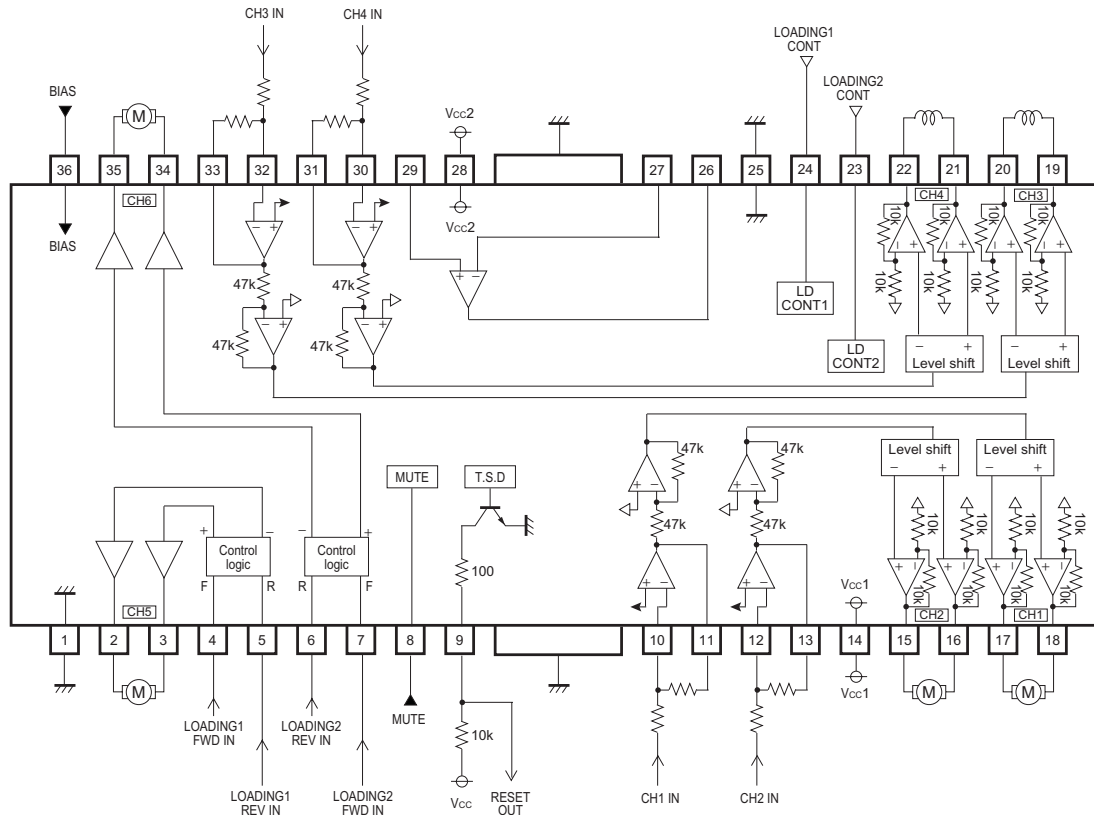

The resistance values are indicated in Ω.

Optical disc ICs

●Operation notes

- (1) BD7960FM has a built-in thermal shutdown circuit.
 When the chip temperature reaches 175°C (Typ.), the output current from all drivers is muted.
 When the chip temperature returns to 150°C (Typ.), the circuit of the driver unit starts up.
- (2) When the mute terminal (8pin) is opened or the terminal voltage is reduced to 0.5V or less, the output current of the BTL driver unit is muted.
 In the normal state of use, pull up the voltage to 2.0V or more.
- (3) When the bias terminal (36pin) voltage is reduced to 0.7V or less, the BTL driver unit is muted.
 In the normal state of use, set the voltage to 1.1V or more.
- (4) Thermal shutdown mutes all drivers. When the mute ON voltage and the bias terminal voltage are reduced, only the BTL drivers are muted. But Opamp are not muted by all condition.
 When the drivers are muted, the BTL driver output terminal voltage becomes the internal bias voltage $(V_{cc1}-0.7)/2V$.
- (5) The loading drivers operate according to the following logic.

INPUT		OUTPUT		Function
FWD	REV	OUT+	OUT-	
L	L	Hi Z	Hi Z	High impedance
L	H	L	H	REV mode
H	L	H	L	FWD mode
H	H	L	L	Brake mode

The output voltage can be changed by adjusting the voltage input to the LDCONT terminal (gain of 6dB Typ.).
 However, even if the input voltage is increased excessively, the output voltage will not exceed the max. output voltage that depends on the supply voltage.

- (6) Supply the same voltage to V_{cc1} (14pin) and V_{cc2} (28pin).
 Insert by the pass capacitor (approx. 0.1 μ F) between V_{cc} pin and GND pin of IC as near as possible.
- (7) Connect the radiating fin with external GND.
- (8) Output pin is to avoid short-circuit with V_{cc} , GND and other output pins.
 An integrated circuit is damaged, and smoke may come out by the case.

●Electrical characteristic curves

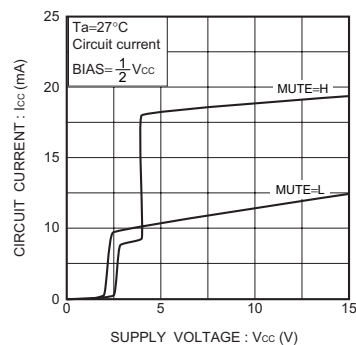

Fig.3 Circuit current characteristic

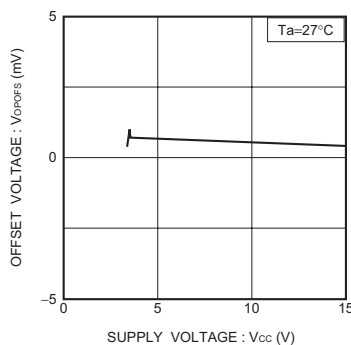

Fig.4 OP-amp offset voltage

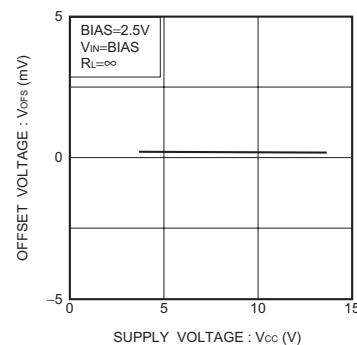

Fig.5 BTL driver offset voltage

Optical disc ICs

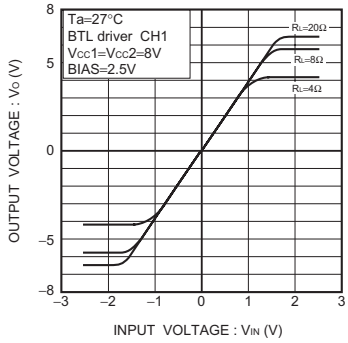

Fig.6 Maximum output amplitude

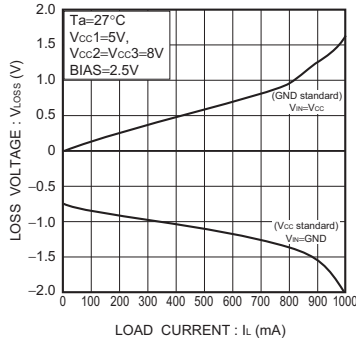

Fig.7 BTL driver output load regulation

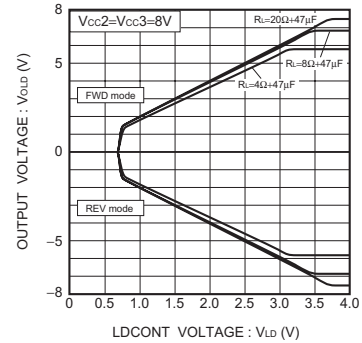

Fig.8 Load driver maximum output amplitude

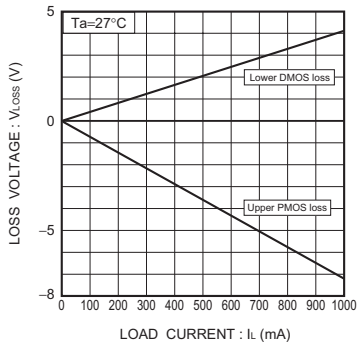

Fig.9 Loading driver output load regulation

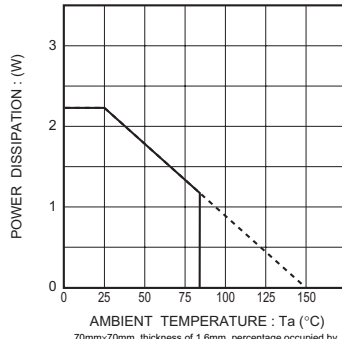
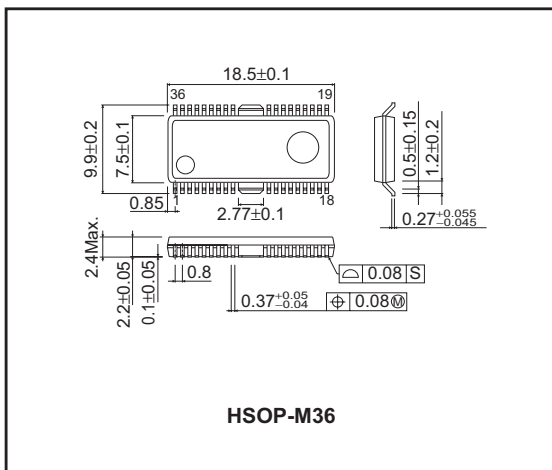



Fig.10 Power dissipation

●External dimensions (Units : mm)



Looking for pricing, stock, or lifecycle information?

Click below to explore more details on WIN SOURCE:

-  [View BD7960FM on WIN SOURCE](#)
-  [Rohm Semiconductor Information](#)

Optimize Your Supply Chain with WIN SOURCE Solutions

-  Global Sourcing Solution
-  Obsolete Management
-  Cost Control Management
-  Shortage Management
-  Alternative Solution
-  Excess Inventory Management