



ISL35411

Quad Driver

FN6971  
Rev 2.00  
June 23, 2016

The [ISL35411](#) is a quad de-emphasis driver with extended functionality for advanced protocols operating with line rates up to 11.1Gbps. It integrates a high-speed driver/limiting amplifier with built-in de-emphasis to compensate for the frequency dependent attenuation of PCB traces and twin-axial copper cables. Supported protocols include 4k/8k video capable DisplayPort v1.3 (HBR1/2/3), InfiniBand (QDR), 40G Ethernet (40GBASECR4/SR4) and 10G SFP+ specification (SFF-8431).

Used in conjunction with Intersil's ISL36411 receive-side equalizer, the ISL35411 enables active copper cable assemblies that support 10G serial data transmission over >15m of twin-axial copper cables.

Operating on a single 1.2V power supply, the ISL35411 enables per channel throughputs of 10Gbps to 11.1Gbps. High data rates are achieved by using Current Mode Logic (CML) inputs and outputs and is packaged in a 4mmx7mm 46 Ld QFN.

Related Literature

- [AN1572](#), "ISL36411 Evaluation Board User Guide"

Features

- Supports four channels with data rates up to 11.1Gbps
- Low power (90mW per channel)
- Low latency
- Adjustable output de-emphasis
- Four drivers in a 4mmx7mm QFN package for straight route through architecture and simplified routing
- Supports 64b/66b encoded data - long run lengths
- Line silence preservation
- 1.2V supply voltage
- TX\_Disable

Applications

- DisplayPort v1.3 active copper cable modules
- QSFP active copper cable modules
- InfiniBand (QDR)
- 40G Ethernet (40GBase-CR4/SR4)
- 100G Ethernet (100GBase-CR10/SR10)
- High-speed printed circuit board (PCB) traces

Benefits

- Thinner gauge cable
- Extends cable reach greater than 3x
- Improved BER

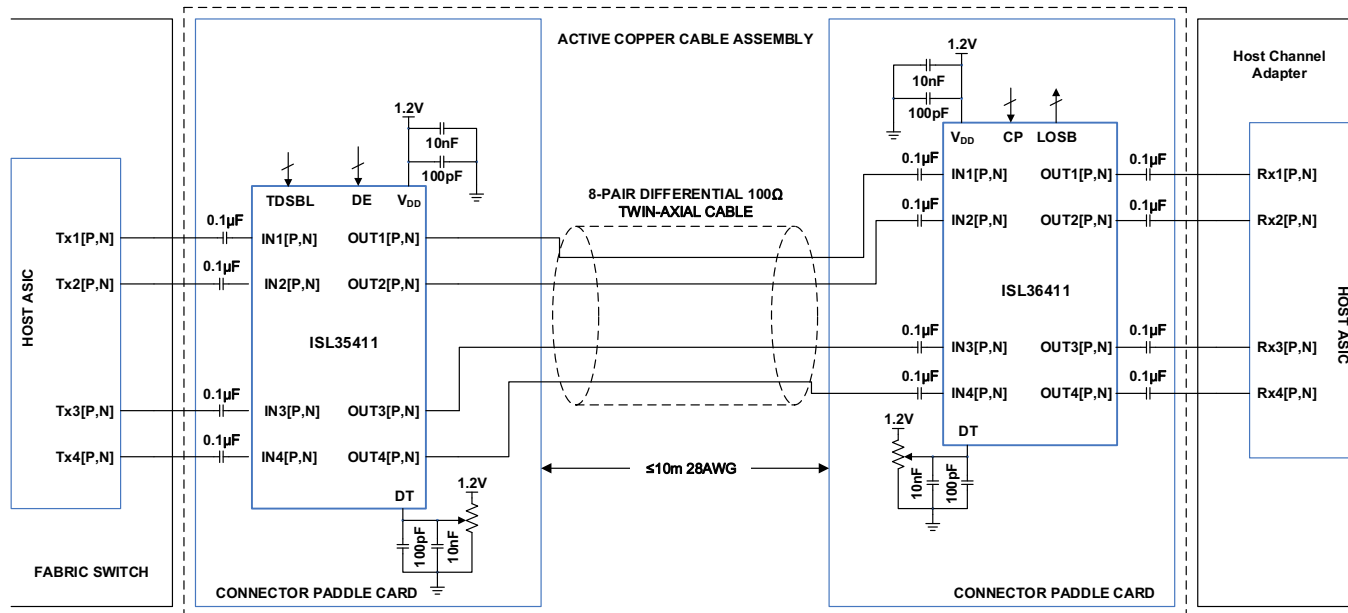

FIGURE 1. TYPICAL APPLICATION CIRCUIT

## Ordering Information

PART NUMBER (Notes 1, 2, 3)	PART MARKING	TEMP. RANGE (°C)	TAPE AND REEL (UNITS)	PACKAGE (RoHS Compliant)	PKG. DWG. #
ISL35411DRZ-TS	ISL35411DRZ	0 to +85	100 (Sample Reel)	46 Ld QFN	L46.4x7
ISL35411DRZ-T7	ISL35411DRZ	0 to +85	1k	46 Ld QFN	L46.4x7
ISL35411DRZ-EVALZ	Evaluation Board				

## NOTES:

- Please refer to [TB347](#) for details on reel specifications.
- These Intersil Pb-free plastic packaged products employ special Pb-free material sets, molding compounds/die attach materials, and 100% matte tin plate plus anneal (e3 termination finish, which is RoHS compliant and compatible with both SnPb and Pb-free soldering operations). Intersil Pb-free products are MSL classified at Pb-free peak reflow temperatures that meet or exceed the Pb-free requirements of IPC/JEDEC J STD-020.
- For Moisture Sensitivity Level (MSL), please see device information page for [ISL35411](#). For more information on MSL please see techbrief [TB363](#).

TABLE 1. KEY DIFFERENCES BETWEEN FAMILY OF PARTS

PART NUMBER	DATA RATE (Gb/s)	NUMBER OF Tx OR Rx	POWER CONSUMPTION (mW)	MAXIMUM CABLE LENGTH (24AWG) (m)	DIFFERENTIAL O/P SWING (mV <sub>P-P</sub> )	DE-EMPHASIS (dB)	EQUALIZATION (dB)	DIFFERENCES BETWEEN QLX PARTS	TARGET MARKET
ISL36411	11	4x Rx	440	20	650	N/A	30	N/A	DP1.3, 40GbE, QSFP+
ISL35411	11	4x Tx	340	20	600	4	N/A	N/A	DP1.3, 40GbE, QSFP+
QLX4600-SL30	6.25	4x Rx	312	30	600	N/A	30	4 pins for Loss of Signal (LOS)	DP1.2, SAS-6Gb, PCIe 2.0
QLX4600-S30	6.25	4x Rx	312	30	600	N/A	30	4 pins for Impedance Selection (= Power Down)	DP1.2, SAS-6Gb, PCIe 2.0

## Pin Configuration

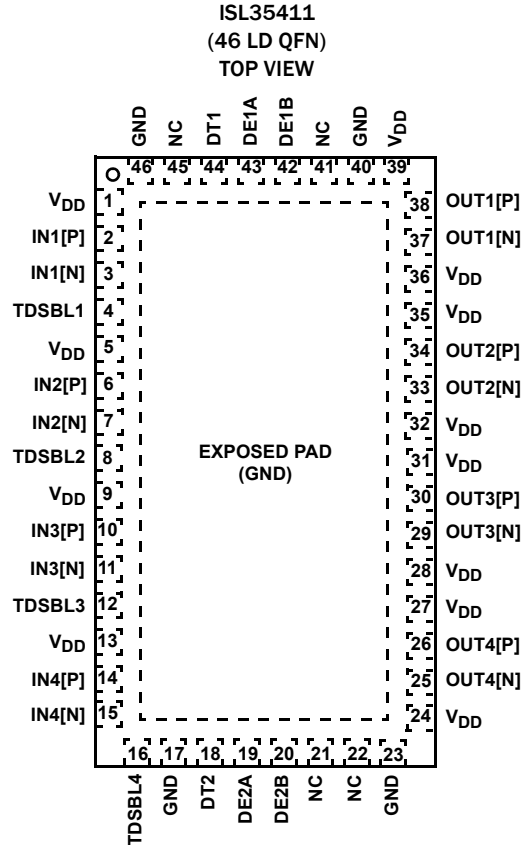

## Pin Descriptions

PIN NAME	PIN NUMBER	DESCRIPTION
V <sub>DD</sub>	1, 5, 9, 13, 24, 27, 28, 31, 32, 35, 36, 39	Power supply. 1.2V supply voltage. The use of parallel 100pF and 10nF decoupling capacitors to ground is recommended for each of these pins for broad high frequency noise suppression.
IN1[P, N]	2, 3	Driver 1 differential input, CML. The use of 100nF low ESL/ESR MLCC capacitor with at least 6GHz frequency response is recommended.
TDSBL1	4	Transmit disable pin for Driver 1. Disables the driver when pulled to V <sub>DD</sub> . Connected to ground for normal operation.
IN2[P, N]	6, 7	Driver 2 differential input, CML. The use of 100nF low ESL/ESR MLCC capacitor with at least 6GHz frequency response is recommended.
TDSBL2	8	Transmit disable pin for Driver 2. Disables the driver when pulled to V <sub>DD</sub> . Connected to ground for normal operation.
IN3[P, N]	10, 11	Driver 3 differential input, CML. The use of 100nF low ESL/ESR MLCC capacitor with at least 6GHz frequency response is recommended.
TDSBL3	12	Transmit disable pin for Driver 3. Disables the driver when pulled to V <sub>DD</sub> . Connected to ground for normal operation.
IN4[P, N]	14, 15	Driver 4 differential input, CML. The use of 100nF low ESL/ESR MLCC capacitor with at least 6GHz frequency response is recommended.
TDSBL4	16	Transmit disable pin for Driver 4. Disables the driver when pulled to V <sub>DD</sub> . Connected to ground for normal operation.
GND	17, 23, 40, 46	These pins should be grounded.

## Pin Descriptions (Continued)

PIN NAME	PIN NUMBER	DESCRIPTION
DT2	18	Detection Threshold for drivers 3 and 4. Reference DC voltage threshold for input signal power detection. Data outputs OUT3 and OUT4 are muted when the power of IN3 and IN4, respectively, fall below the threshold. Tie to ground to disable electrical idle preservation and always enable the limiting amplifier.
DE2[A, B]	19, 20	Control pins for setting de-emphasis on drivers 3 and 4. CMOS logic inputs. Pins are read as a 2-digit number to set the de-emphasis level. A is the MSB and B is the LSB. Pins are internally pulled up and pulled down with 25k $\Omega$ resistors.
NC	21, 22, 41, 45	Not connected: Do not make any connections to these pins.
OUT4[N, P]	25, 26	Driver 4 differential output, CML. The use of 100nF low ESL/ESR MLCC capacitor with at least 6GHz frequency response is recommended.
OUT3[N, P]	29, 30	Driver 3 differential output, CML. The use of 100nF low ESL/ESR MLCC capacitor with at least 6GHz frequency response is recommended.
OUT2[N, P]	33, 34	Driver 2 differential output, CML. The use of 100nF low ESL/ESR MLCC capacitor with at least 6GHz frequency response is recommended.
OUT1[N, P]	37, 38	Driver 1 differential output, CML. The use of 100nF low ESL/ESR MLCC capacitor with at least 6GHz frequency response is recommended.
DE1[B, A]	42, 43	Control pins for setting de-emphasis on drivers 1 and 2. CMOS logic inputs. Pins are read as a 2-digit number to set the de-emphasis level. A is the MSB and B is the LSB. Pins are internally pulled up and pulled down with 25k $\Omega$ resistors.
DT1	44	Detection Threshold for drivers 1 and 2. Reference DC voltage threshold for input signal power detection. Data outputs OUT1 and OUT2 are muted when the power of IN1 and IN2, respectively, fall below the threshold. Tie to ground to disable electrical idle preservation and always enable the limiting amplifier.
Exposed Pad	-	Exposed ground pad. For proper electrical and thermal performance, this pad should be connected to the PCB ground plane.

**Absolute Maximum Ratings**

Supply Voltage ( $V_{DD}$ to GND)	-0.3V to 1.5V
Voltage at All Input Pins	-0.3V to 1.5V
ESD Ratings	
Human Body Model	
High-Speed Pins	1.5kV
All Other Pins	2kV

**Thermal Information**

Thermal Resistance (Typical)	$\theta_{JA}$ ( $^{\circ}\text{C}/\text{W}$ )	$\theta_{JC}$ ( $^{\circ}\text{C}/\text{W}$ )
46 Ld QFN Package (Notes 4, 5)	33	2.8
Operating Ambient Temperature Range	0 $^{\circ}\text{C}$ to +85 $^{\circ}\text{C}$	
Storage Ambient Temperature Range	-55 $^{\circ}\text{C}$ to +150 $^{\circ}\text{C}$	
Maximum Junction Temperature	+125 $^{\circ}\text{C}$	
Pb-Free Reflow Profile	see <a href="#">TB493</a>	

CAUTION: Do not operate at or near the maximum ratings listed for extended periods of time. Exposure to such conditions may adversely impact product reliability and result in failures not covered by warranty.

## NOTES:

- $\theta_{JA}$  measured in free air with the component mounted on a high effective thermal conductivity test board with "direct attach" features. See Tech Brief [TB379](#).
- For  $\theta_{JC}$ , the "case temp" location is the center of the exposed metal pad on the package underside.

**Operating Conditions**

PARAMETER	SYMBOL	TEST CONDITIONS	MIN (Note 6)	TYP	MAX (Note 6)	UNIT
Supply Voltage	$V_{DD}$		1.1	1.2	1.3	V
Operating Ambient Temperature	$T_A$		0	25	85	$^{\circ}\text{C}$
Bit Rate		NRZ data applied to any channel		10	11.1	Gbps

**Control Pin Characteristics**  $V_{DD} = 1.2\text{V}$ ,  $T_A = +25^{\circ}\text{C}$  and  $V_{IN} = 600\text{mV}_{P-P}$ , unless otherwise noted.

PARAMETER	SYMBOL	TEST CONDITIONS	MIN (Note 6)	TYP	MAX (Note 6)	UNIT
Input LOW Logic Level	$V_{IL}$		0		350	mV
Input HIGH Logic Level	$V_{IH}$		750		$V_{DD}$	mV
Input Current		Current draw on digital pin, i.e., DE[k][A, B]		100	200	$\mu\text{A}$

**Electrical Specifications**  $V_{DD} = 1.2\text{V}$ ,  $T_A = +25^{\circ}\text{C}$  and  $V_{IN} = 600\text{mV}_{P-P}$ , unless otherwise noted.

PARAMETER	SYMBOL	TEST CONDITIONS	MIN (Note 6)	TYP	MAX (Note 6)	UNIT	NOTES
Supply Current	$I_{DD}$	De-emphasis disabled (Note 7)		260		mA	<a href="#">7</a>
		De-emphasis enabled (Note 7)		300		mA	<a href="#">7</a>
		Transmit Disable mode (Note 7)		5.6		mA	<a href="#">7</a>
Input Amplitude Range	$V_{IN}$	Measured differentially at data source	120		1600	$\text{mV}_{P-P}$	
DC Differential Input Resistance		Measured on input channel IN[k]	80	100	120	$\Omega$	
DC Single-Ended Input Resistance		Measured on input channel IN[k]P or IN[k]N, with respect to $V_{DD}$	40	50	60	$\Omega$	
Input Return Loss Limit (Differential)	$S_{DD11}$	100MHz to 4.1GHz		<a href="#">Note 8</a>		dB	<a href="#">8</a>
		4.1GHz to 11.1GHz		<a href="#">Note 9</a>		dB	<a href="#">9</a>
Input Return Loss Limit (Common-Mode)	$S_{CC11}$	100MHz to 2.5GHz		<a href="#">Note 10</a>		dB	<a href="#">10</a>
		2.5GHz to 11.1GHz		-3		dB	<a href="#">13</a>
Input Return Loss Limit (Com. to Diff. Conversion)	$S_{DC11}$	100MHz to 11.1GHz		-10		dB	<a href="#">13</a>
Output Amplitude Range	$V_{OUT}$	Measured differentially at OUT[k]P and OUT[k]N with 50 $\Omega$ load on both output pins de-emphasis disabled	450	700	820	$\text{mV}_{P-P}$	
Differential Output Impedance		Measured on OUT[k]	80	105	120	$\Omega$	

**Electrical Specifications**  $V_{DD} = 1.2V$ ,  $T_A = +25^\circ C$  and  $V_{IN} = 600mV_{P-P}$ , unless otherwise noted. (Continued)

PARAMETER	SYMBOL	TEST CONDITIONS	MIN (Note 6)	TYP	MAX (Note 6)	UNIT	NOTES
Output Return Loss Limit (Differential)	$S_{DD22}$	100MHz to 4.1GHz		<a href="#">Note 8</a>		dB	<a href="#">8</a>
		4.1GHz to 11.1GHz		<a href="#">Note 9</a>		dB	<a href="#">9</a>
Output Return Loss Limit (Common-Mode)	$S_{CC22}$	100MHz to 2.5GHz		<a href="#">Note 10</a>		dB	<a href="#">10</a>
		2.5GHz to 11.1GHz		-3		dB	<a href="#">13</a>
Output Return Loss Limit (Com. to Diff. Conversion)	$S_{DC22}$	100MHz to 11.1GHz		-10		dB	<a href="#">13</a>
Residual Deterministic Jitter		11.1Gbps; no channel attenuation; de-emphasis disabled		0.1		UI	<a href="#">11</a>
Random Jitter				0.7		$ps_{RMS}$	
Output Transition Time	$t_r, t_f$	20% to 80%		35		ps	<a href="#">12</a>
Minimum De-Emphasis Level				0		dB	
Maximum De-Emphasis Level				4		dB	
De-Emphasis Resolution				0.5		dB	

## NOTES:

6. Compliance to datasheet limits is assured by one or more methods: production test, characterization and/or design.
7. Temperature =  $+25^\circ C$ ,  $V_{DD} = 1.2V$ .
8. Maximum Reflection Coefficient given by equation  $SDDXX(dB) = -12 + 2*\sqrt{f}$ , with f in GHz. Established by characterization and not production tested.
9. Maximum Reflection Coefficient given by equation  $SDDXX(dB) = -6.3 + 13\text{Log}_{10}(f/5.5)$ , with f in GHz. Established by characterization and not production tested.
10. Reflection Coefficient given by equation  $SCCXX(dB) < -7 + 1.6*f$ , with f in GHz. Established by characterization and not production tested.
11. Measured using a PRBS  $2^7-1$  pattern.
12. Rise and fall times measured with a 1-1-1-1-1-1-1-1-0-0-0-0-0-0-0-0 test pattern at 11.1Gbps with no channel loss and disabled de-emphasis.
13. Limits established by characterization and are not production tested.

## Typical Performance Characteristics

Performance is measured using the test setup illustrated in [Figure 2](#). The signal from the pattern generator is launched into the chip evaluation board. The ISL35411 output signal is then visualized on a scope to determine signal integrity parameters such as jitter.

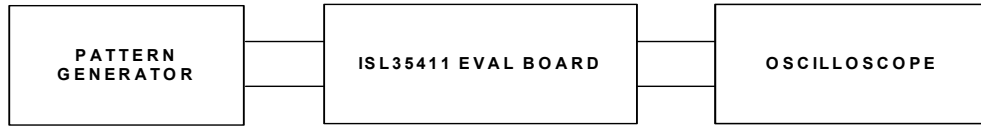

FIGURE 2. DEVICE CHARACTERIZATION TEST SETUP

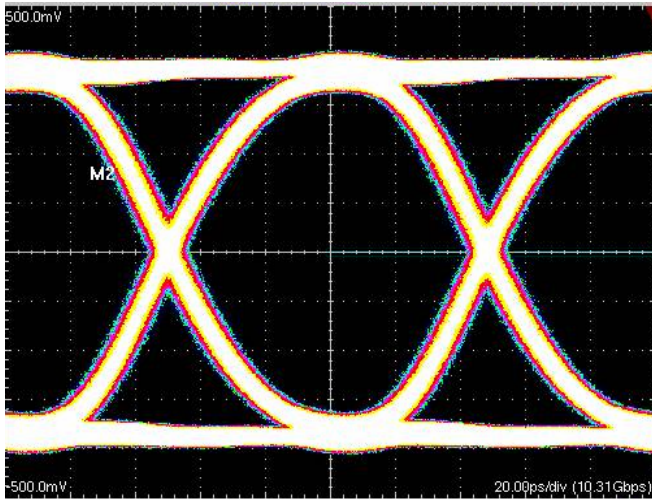

FIGURE 3A. DE-EMPHASIS 0

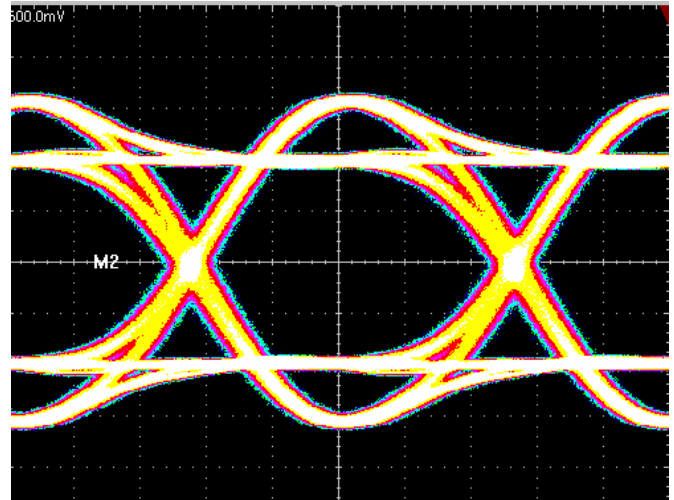

FIGURE 3B. DE-EMPHASIS 6

FIGURE 3. 10.3125Gbps OUTPUT; NO CHANNEL; PRBS-31

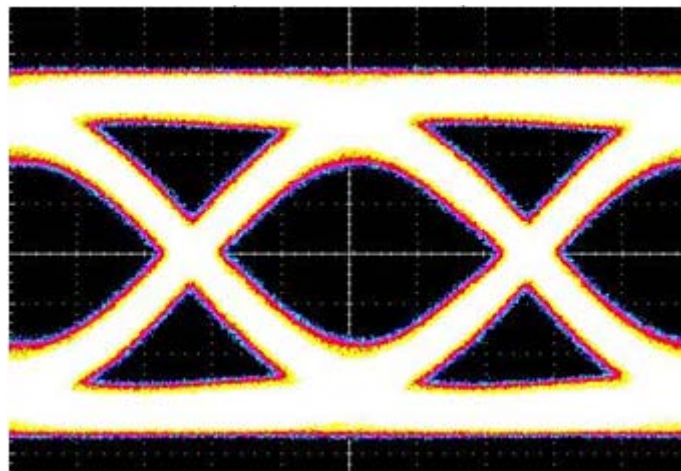

FIGURE 4. 10.3125 GBPS OUTPUT AFTER A 22-INCH FR-408 TRACE, PRBS-31; DE-EMPHASIS 6

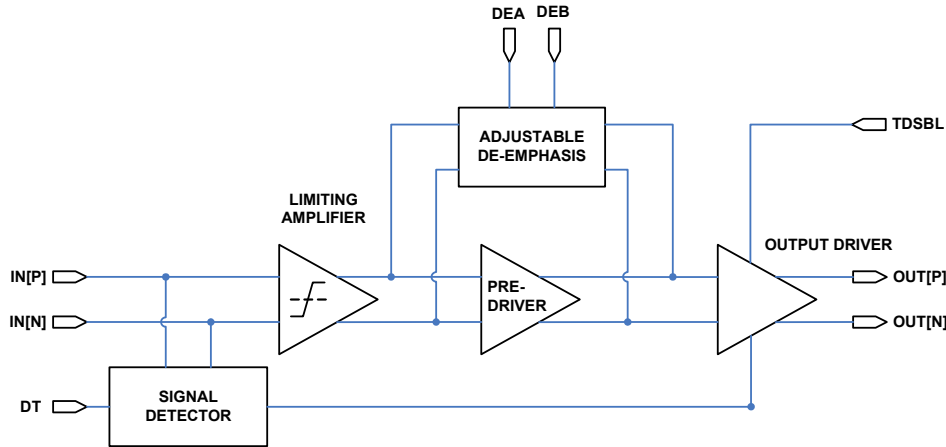

FIGURE 5. FUNCTIONAL DIAGRAM OF A SINGLE CHANNEL WITHIN THE ISL35411

## Operation

The ISL35411 is an advanced driver for high-speed interconnects. A functional diagram of ISL35411 is shown in [Figure 5](#). In addition to a de-emphasis circuit to compensate for channel loss and improve signal fidelity, the ISL35411 contains unique integrated features to preserve special signaling protocols typically broken by other drivers. The signal detect function is used to mute the channel output when the equalized signal falls below the level determined by the Detection Threshold (DT) pin voltage. This function is intended to preserve periods of line silence.

As illustrated in [Figure 5](#), the core of the high-speed signal path in the ISL35411 is a sophisticated driver followed by a de-emphasis circuit. The device applies predistortion to compensate for skin effect loss, dielectric loss and impedance discontinuities in the transmission channel.

### Adjustable De-Emphasis

ISL35411 features a settable de-emphasis driver for custom signal restoration.

The voltages at the DE pins are used to determine the de-emphasis levels of each 2-channel group – from 0dB to 4dB in 0.5dB increments. For each two of the four channels the [A] and [B] control pins DE[k] are associated with a non binary word. [A] and [B] can take one of three different values: ‘LOW’, ‘MIDDLE’, or ‘HIGH’. This is achieved by leaving the DE pins floating or connecting them either to  $V_{DD}$  or GND through 0 $\Omega$  resistors. [Table 2](#) defines the mapping from the 2-bit DE word to the 7 possible de-emphasis levels.

TABLE 2. MAPPING BETWEEN DE-EMPHASIS LEVEL AND DE-PIN CONNECTIVITY

DE PIN CONNECTION		NOMINAL DE-EMPHASIS LEVEL; 10.3125Gbps TO 11.1Gbps (dB)	DE-EMPHASIS SETTING
DE[A]	DE[B]		
Open	Open	0	0
Open	GND	0.6	1
Open	$V_{DD}$	1.1	2
GND	Open	1.6	3
GND	GND	2.3	4
GND	$V_{DD}$	3	5
$V_{DD}$	Open	4	6

### Line Silence/Quiescent Mode

The ISL35411 is capable of maintaining periods of line silence by monitoring its input pins for Loss Of Signal (LOS) conditions and subsequently muting the output drivers when such a condition is detected. A reference voltage applied to the Detection Threshold DT[k] pins is used to set the LOS threshold of the internal signal detection circuitry. For most applications, it is recommended to leave the DT pin floating at its default internal bias. If the sensitivity of the detection threshold needs to be adjusted, the DT voltage can be adjusted with an external pull-up resistor. The resistor values should be validated on an application-specific basis. Connect the DT pin to ground in order to disable this feature and prevent the outputs from muting during line silence.

## PCB Layout Considerations

Because of the high speed of the ISL35411 signals, careful PCB layout is critical to maximize performance. The following guidelines should be adhered to as closely as possible:

- All high speed differential pair traces should have a characteristic impedance of  $50\Omega$  with respect to ground plane and  $100\Omega$  with respect to each other.
- Avoid using vias for high speed traces as this will create discontinuity in the traces' characteristic impedance.
- Input and output traces need to have DC blocking capacitors (100nF). Capacitors should be placed as close to the chip as possible.
- For each differential pair, the positive trace and the negative trace need to be of the same length in order to avoid intra-pair skew. A Serpentine technique may be used to match trace lengths.
- Maintain a constant solid ground plane underneath the high-speed differential traces.
- Each  $V_{DD}$  pin should be connected to 1.2V and also bypassed to ground through a 10nF and a 100pF capacitor in parallel. Minimize the trace length and avoid vias between the  $V_{DD}$  pin and the bypass capacitors in order to maximize the power supply noise rejection.
- If 4 channels of the device are set to the same boost, then the quantity of CP resistors can be reduced by tying both CP pins together.

## About Q:Active

Intersil has long realized that to enable the complex server clusters of next generation data centers, it is critical to manage the signal integrity issues of electrical interconnects. To address this, Intersil has developed its groundbreaking Q:ACTIVE™ product line. By integrating its analog ICs inside cabling interconnects, Intersil is able to achieve unsurpassed improvements in reach, power consumption, latency and cable gauge size as well as increased airflow in tomorrow's data centers. This new technology transforms passive cabling into intelligent “roadways” that yield lower operating expenses and capital expenditures for the expanding data center.

Intersil Lane Extenders allow greater reach over existing cabling, while reducing the need for thicker cables. This significantly reduces cable weight and clutter, increases airflow and improves power consumption.

# Application Information

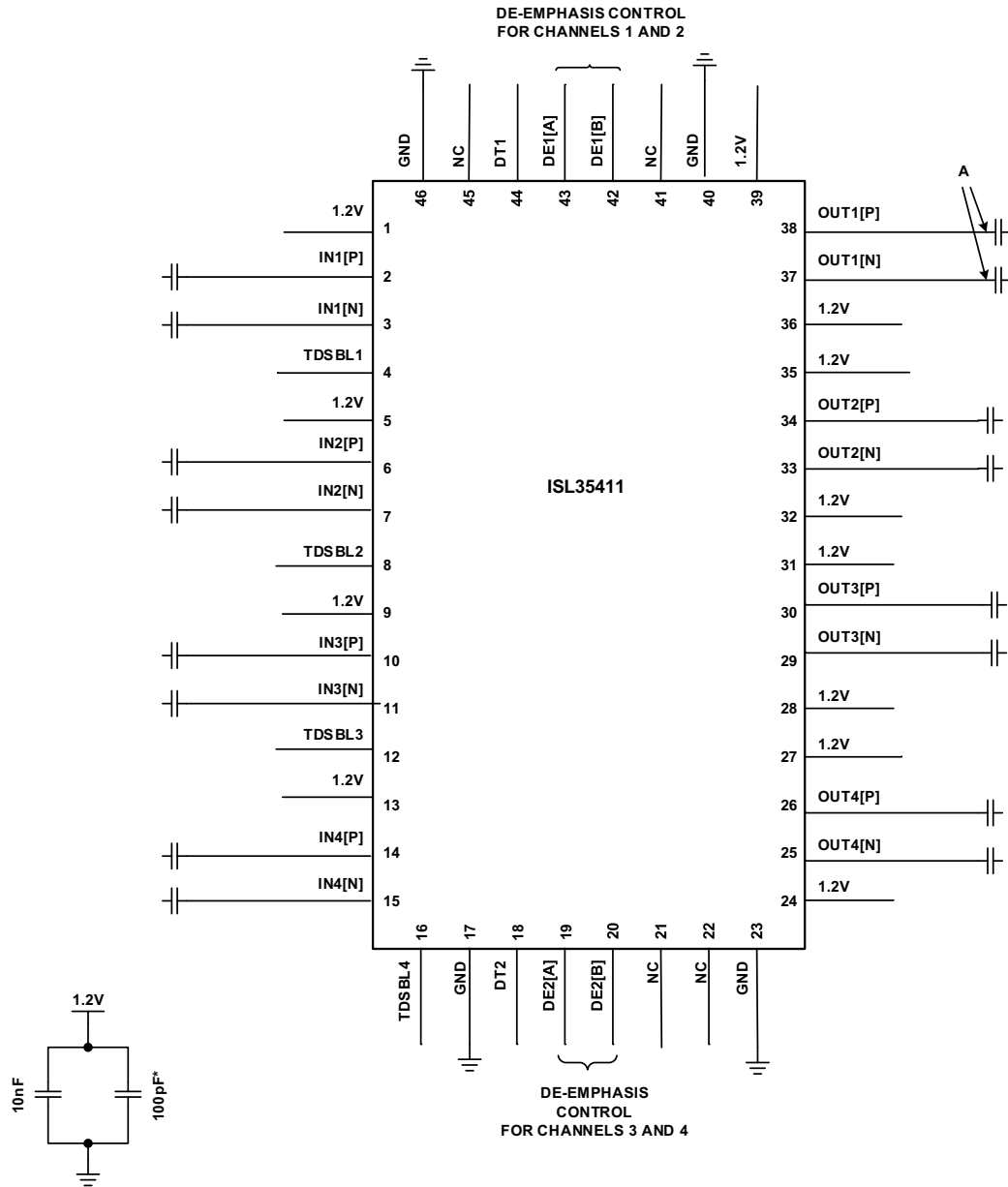

BYPASS CIRCUIT FOR EACH V<sub>DD</sub> PIN  
 (\*100pF CAPACITOR SHOULD BE POSITIONED CLOSEST TO THE PIN)

A) DC BLOCKING CAPACITORS = X7R or COG 0.1µF (>6GHz BANDWIDTH)

**NOTES:**

- 14. See [“Adjustable De-Emphasis” on page 8](#) for information on how to connect the DE pins.
- 15. See [“Line Silence/Quiescent Mode” on page 8](#) for details on DT pin operation.

**FIGURE 6. TYPICAL APPLICATION REFERENCE SCHEMATIC**

## Revision History

The revision history provided is for informational purposes only and is believed to be accurate, but not warranted.

Please go to web to make sure you have the latest Rev.

DATE	REVISION	CHANGE
June 23, 2016	FN6971.2	Updated page 1 description of part. Added applications bullet "DisplayPort v1.3 active copper cable modules". Removed "High-speed active cable assemblies" application bullet. Added Related Literature section on page 1. Added Table 1 on page 2. Added Note 6 on page 6. Replaced Products section with the About Intersil section. Updated POD L46.4x7 to the latest revision changes are as follows: -3/15/13 Side view, changed pkg thickness from 0.70+/-0.05 to 0.75+/-0.05 Detail x, changed from 0.152 REF to 0.203 REF.
March 16, 2010	FN6971.1	Page 5: Control pin characteristics: change 'output low/high' to 'input', change symbols to VIL/VIH; condition - blank VIL: min 0, max 350, delete typical "0" VIH: min 750 mV Input current: typ 100; max 200 Added High-Speed pins to ESD Ratings as follows to Abs Max Ratings: ESD Ratings Human Body Model High-Speed Pins 1.5kV All Other Pins 2kV Removed the land pattern on page 9 due to information already in outline drawing.
February 8, 2010	FN6971.0	Initial release

## About Intersil

Intersil Corporation is a leading provider of innovative power management and precision analog solutions. The company's products address some of the largest markets within the industrial and infrastructure, mobile computing and high-end consumer markets.

For the most updated datasheet, application notes, related documentation and related parts, please see the respective product information page found at [www.intersil.com](http://www.intersil.com).

You may report errors or suggestions for improving this datasheet by visiting [www.intersil.com/ask](http://www.intersil.com/ask).

Reliability reports are also available from our website at [www.intersil.com/support](http://www.intersil.com/support).

© Copyright Intersil Americas LLC 2010-2016. All Rights Reserved.

All trademarks and registered trademarks are the property of their respective owners.

For additional products, see [www.intersil.com/en/products.html](http://www.intersil.com/en/products.html)

Intersil products are manufactured, assembled and tested utilizing ISO9001 quality systems as noted in the quality certifications found at [www.intersil.com/en/support/qualandreliability.html](http://www.intersil.com/en/support/qualandreliability.html)

*Intersil products are sold by description only. Intersil may modify the circuit design and/or specifications of products at any time without notice, provided that such modification does not, in Intersil's sole judgment, affect the form, fit or function of the product. Accordingly, the reader is cautioned to verify that datasheets are current before placing orders. Information furnished by Intersil is believed to be accurate and reliable. However, no responsibility is assumed by Intersil or its subsidiaries for its use; nor for any infringements of patents or other rights of third parties which may result from its use. No license is granted by implication or otherwise under any patent or patent rights of Intersil or its subsidiaries.*

For information regarding Intersil Corporation and its products, see [www.intersil.com](http://www.intersil.com)



## Looking for pricing, stock, or lifecycle information?

Click below to explore more details on WIN SOURCE:

-  [View ISL35411DRZ-TS on WIN SOURCE](#)
-  [Renesas Electronics America](#) Information

## Optimize Your Supply Chain with WIN SOURCE Solutions

-  Global Sourcing Solution
-  Obsolete Management
-  Cost Control Management
-  Shortage Management
-  Alternative Solution
-  Excess Inventory Management