



**THE DATASHEET OF
ISL29009IROZ-T7**



ISL29009

Non-Linear Output Current, Low Power Ambient Light Photo Detect IC

FN6484
Rev 0.00
July 1, 2008

The ISL29009 is a light-to-current silicon optical sensor combining a photodiode and current amplifiers on a single monolithic IC. Similar to human eyes, the photodiode has peak sensitivity at 550nm and spans from 400nm to 700nm, rejecting UV light and IR light. The input luminance range is from 0.3 lux to 10,000 lux.

The integrated non-linear current amplifier boosts and converts the photodiode signal in a square root fashion, extending the light input dynamic range while maintaining excellent sensitivity at dim conditions with low lux levels. The device consumes minimal power over a wide range of ambient lux levels because the current consumption ramps at a square root fashion. A dark current compensation circuit aids the photodiode to minimize temperature dependent leakage currents in the absence of light, improving the light sensitivity at low lux levels.

In addition, the ISL29009 has an \overline{EN} pin that can be used for a polling scheme extending portables' battery life.

The ISL29009 is housed in an ultra compact 2mmx2.1mm ODFN plastic case surface mount package. Operation is rated from -40°C to +85°C.

Simplified Block Diagram

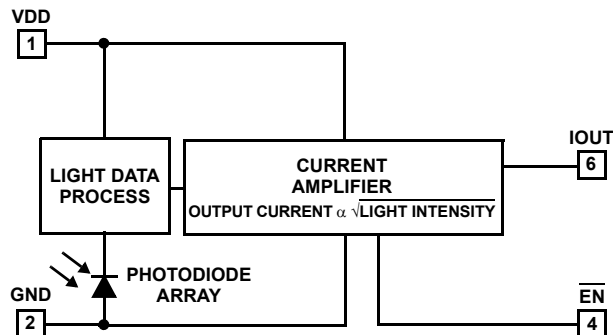

Ordering Information

PART NUMBER (Note)	TEMP. RANGE (°C)	PACKAGE (Pb-free)	PKG. DWG. #
ISL29009IROZ-T7*	-40 to +85	6 Ld ODFN	L6.2x2.1

*Please refer to TB347 for details on reel specifications.

NOTE: These Intersil Pb-free plastic packaged products employ special Pb-free material sets; molding compounds/die attach materials and NiPdAu plate - e4 termination finish, which is RoHS compliant and compatible with both SnPb and Pb-free soldering operations. Intersil Pb-free products are MSL classified at Pb-free peak reflow temperatures that meet or exceed the Pb-free requirements of IPC/JEDEC J STD-020.

Features

- Non-linear current output
- 0.3 lux to 10,000 lux range
- Dark current compensation
- Temperature compensated
- Human eye response
- 1.8V to 3.3V supply range
- Low supply current
- Fast response time
- 6 Ld ODFN: 2mmx2.1mmx0.7mm
- Pb-free (RoHS compliant)

Applications

- Display and keypad dimming for:
 - Mobile devices: smart phone, PDA, GPS
 - Computing devices: notebook PC, webpod
 - Consumer devices: LCD-TV, digital picture frame, digital camera
- Industrial and medical light sensing

Pinout

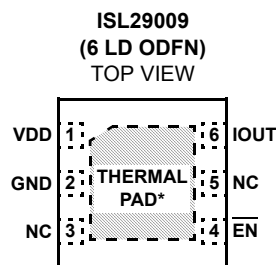

*THERMAL PAD CAN BE CONNECTED TO GND OR ELECTRICALLY ISOLATED

Pin Descriptions

PIN NUMBER	PIN NAME	DESCRIPTION
1	VDD	Supply, 1.8V to 3.3V
2	GND	Ground
3	NC	No connect
4	\overline{EN}	Active LO enable
5	NC	No connect
6	IOUT	Current output

Absolute Maximum Ratings ($T_A = +25^\circ\text{C}$)

Supply Voltage between VDD and GND	3.6V
Pin Voltage (IOUT and $\overline{\text{EN}}$)	-0.2V to VDD
Maximum Continuous Output Current	6mA
Operating Temperature	-40°C to +85°C
ESD Rating	
Human Body Model	.2kV
Machine Model	.200V

Thermal Information

Thermal Resistance	θ_{JA} ($^\circ\text{C}/\text{W}$)
6 Ld ODFN	90
Maximum Die Temperature	+90°C
Storage Temperature	-40°C to +100°C
Operating Temperature	-40°C to +85°C
Pb-free reflow profile	see link below
	http://www.intersil.com/data/tb/TB477.pdf

CAUTION: Do not operate at or near the maximum ratings listed for extended periods of time. Exposure to such conditions may adversely impact product reliability and result in failures not covered by warranty.

IMPORTANT NOTE: All parameters having Min/Max specifications are guaranteed. Typical values are for information purposes only. Unless otherwise noted, all tests are at the specified temperature and are pulsed tests, therefore: $T_J = T_C = T_A$

Electrical Specifications $V_{DD} = 3\text{V}$, $T_A = +25^\circ\text{C}$, $\overline{\text{EN}} = 0$, $R_L = 100\text{k}\Omega$ at IOUT pin, green LED light, unless otherwise specified.

PARAMETER	DESCRIPTION	CONDITION	MIN	TYP	MAX	UNIT
E	Range of Input Light Intensity			0.3 to 10k		lux
VDD	Power Supply Range		1.8		3.3	V
I _{DD}	Supply Current	E = 1000 lux		9	14	μA
		E = 100 lux		3		μA
		E = 0 lux		0.25		μA
I _{SD}	Supply Current when Shut Down	$\overline{\text{EN}} = V_{DD}$		250	350	nA
I _{OUT1}	Light-to-Current Accuracy	E = 100 lux		1.8		μA
I _{OUT2}	Light-to-Current Accuracy	E = 1000 lux	4.6	5.7	6.8	μA
I _{DARK}	Dark Current Output in the Absence of Light	E = 0 lux, $R_L = 10\text{M}\Omega$		2	5	nA
ΔI_{OUT}	Output Current Variation Over Three Light Sources: Fluorescent, Incandescent and Halogen			10		%
V _{O-MAX}	IOUT Max Output Compliance Voltage at 95% of Nominal Output	E = 1000 lux		$V_{DD} - 0.2$		V
t _R	IOUT Rise Time (Note 1)	$R_L = 100\text{k}\Omega$, E = 300 lux from 0 Lux		70		μs
		$R_L = 100\text{k}\Omega$, E = 1000 lux from 0 Lux		20		μs
t _F	IOUT Fall Time (Note 1)	$R_L = 100\text{k}\Omega$, E = 300 lux to 0 Lux		2410		μs
		$R_L = 100\text{k}\Omega$, E = 1000 lux to 0 Lux		1290		μs
t _D	IOUT Delay Time for Rising Edge (Note 1)	$R_L = 100\text{k}\Omega$, E = 300 lux from 0 Lux		600		μs
		$R_L = 100\text{k}\Omega$, E = 1000 lux from 0 Lux		280		μs
t _S	IOUT Delay Time for Falling Edge (Note 1)	$R_L = 100\text{k}\Omega$, E = 300 lux to 0 Lux		75		μs
		$R_L = 100\text{k}\Omega$, E = 1000 lux to 0 Lux		5		μs
V _{LO}	Maximum Voltage at $\overline{\text{EN}}$ pin to Enable			0.5		V
V _{HI}	Minimum Voltage at $\overline{\text{EN}}$ pin to Disable			$V_{DD} - 0.5$		V
I _{LO}	Input Current at $\overline{\text{EN}}$ pin	$V_{\overline{\text{EN}}} = 0\text{V}$		1		nA
I _{HI}	Input Current at $\overline{\text{EN}}$ pin	$V_{\overline{\text{EN}}} = 3\text{V}$		1		nA

Electrical Specifications $V_{DD} = 3V$, $T_A = +25^\circ C$, $\overline{EN} = 0$, $R_L = 100k\Omega$ at IOOUT pin, green LED light, unless otherwise specified.
(Continued)

PARAMETER	DESCRIPTION	CONDITION	MIN	TYP	MAX	UNIT
t_{EN}	Enable Time	$R_L = 100k\Omega$, $E = 100$ lux		20		μs
t_{DIS}	Disable Time	$R_L = 100k\Omega$, $E = 100$ lux		200		μs

NOTE:

1. Switching time measurement is based on Figures 1 and 2.

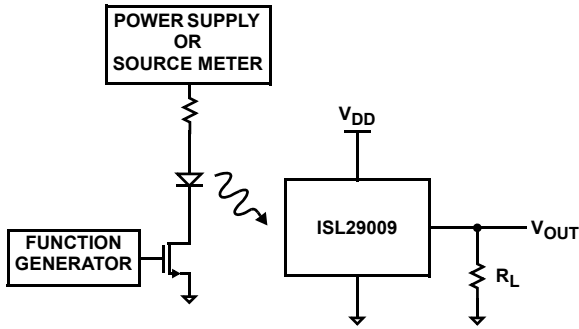

FIGURE 1. TEST CIRCUIT FOR RISE/FALL TIME MEASUREMENT

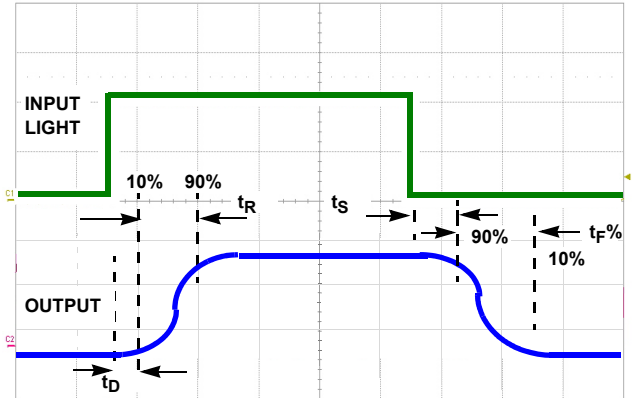

FIGURE 2. TIMING DIAGRAM

Typical Performance Curves

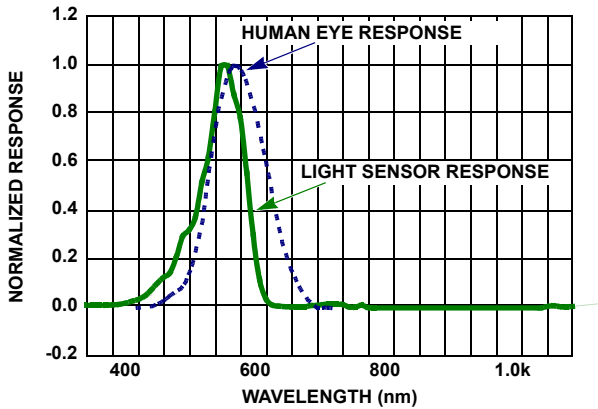

FIGURE 3. SPECTRAL RESPONSE

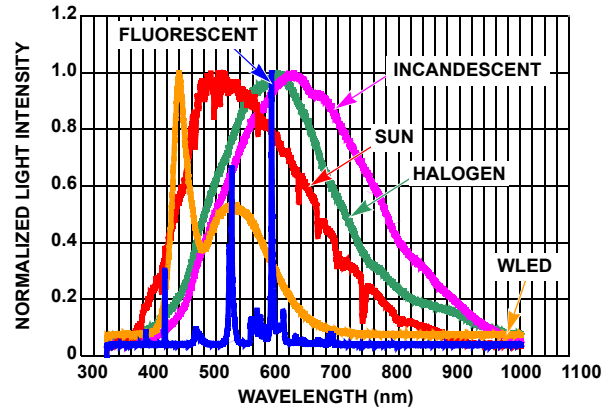

FIGURE 4. SPECTRUM OF LIGHT SOURCES

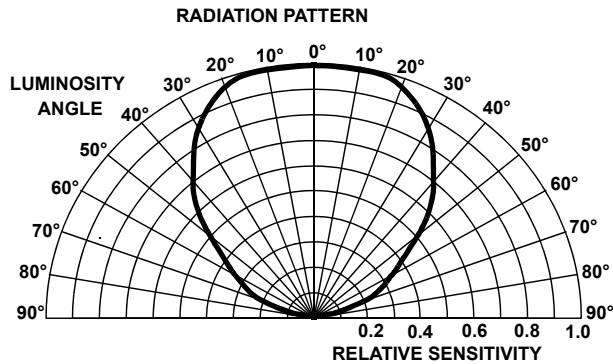

FIGURE 5. RADIATION PATTERN

Typical Performance Curves (Continued)

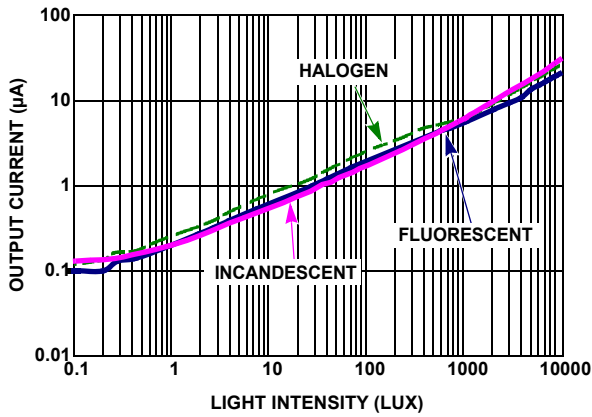

FIGURE 6. OUTPUT CURRENT vs LIGHT INTENSITY

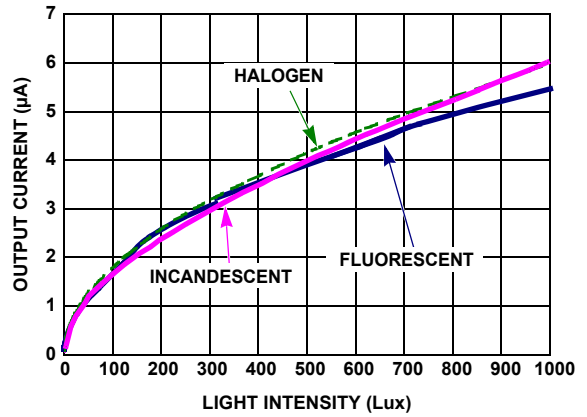

FIGURE 7. OUTPUT CURRENT vs LIGHT INTENSITY

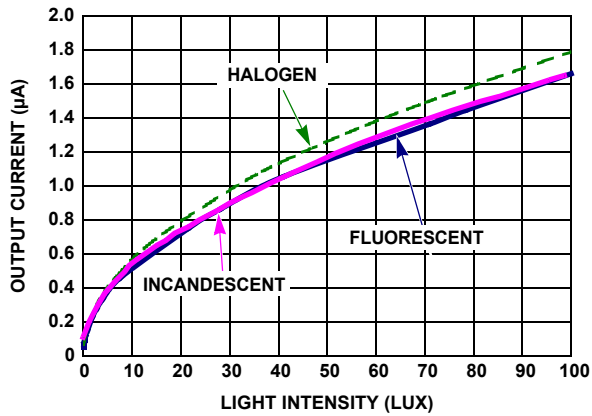

FIGURE 8. OUTPUT CURRENT vs LIGHT INTENSITY

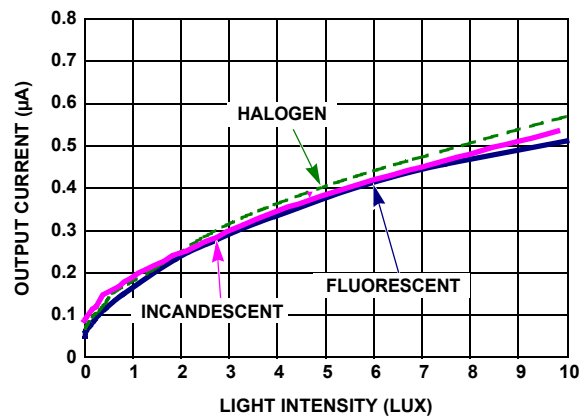

FIGURE 9. OUTPUT CURRENT vs LIGHT INTENSITY

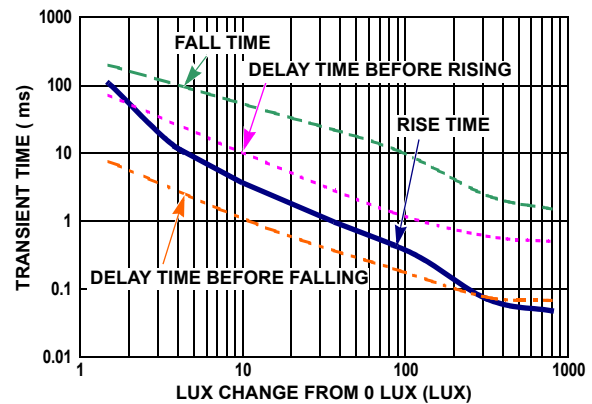

FIGURE 10. TRANSIENT TIME vs LUX CHANGE FROM 0 LUX

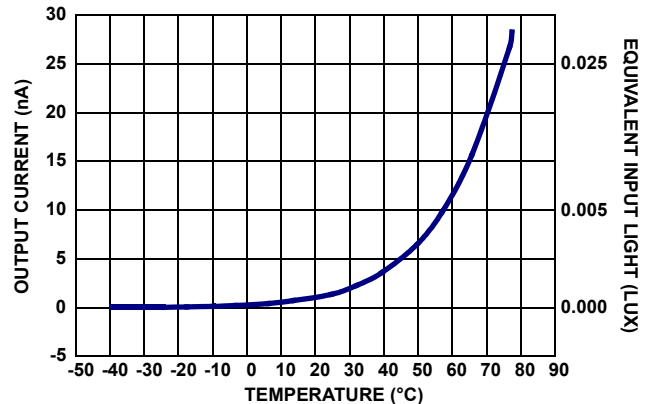

FIGURE 11. OUTPUT CURRENT vs TEMPERATURE AT 0 LUX

Typical Performance Curves (Continued)

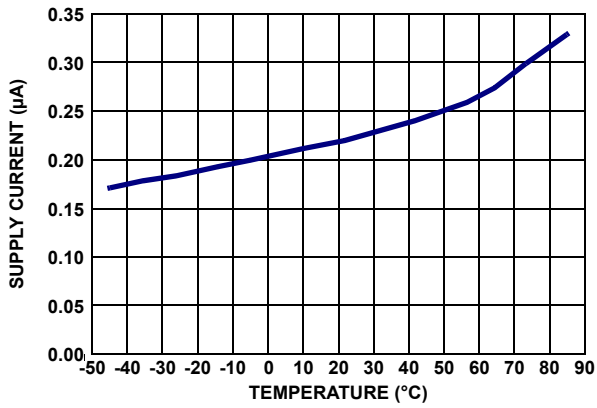

FIGURE 12. SUPPLY CURRENT vs TEMPERATURE AT 0 LUX

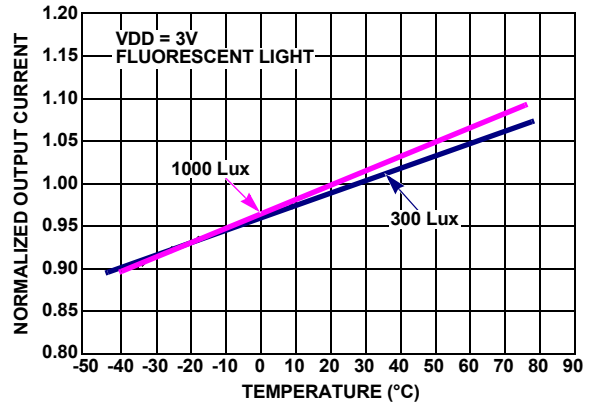

FIGURE 13. NORMALIZED OUTPUT CURRENT vs TEMPERATURE

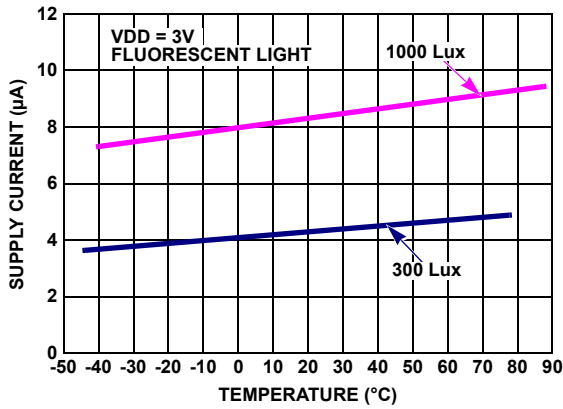

FIGURE 14. SUPPLY CURRENT vs TEMPERATURE

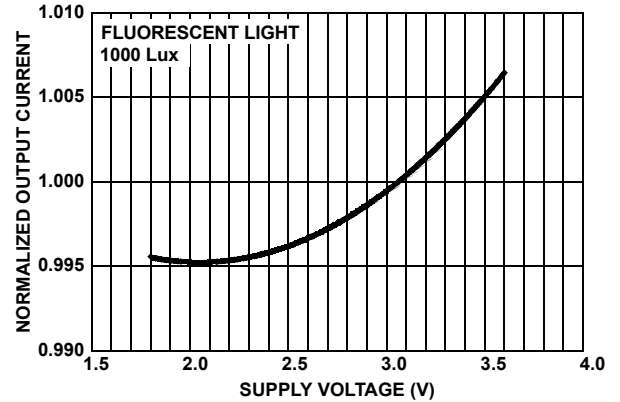

FIGURE 15. NORMALIZED OUTPUT CURRENT vs SUPPLY VOLTAGE

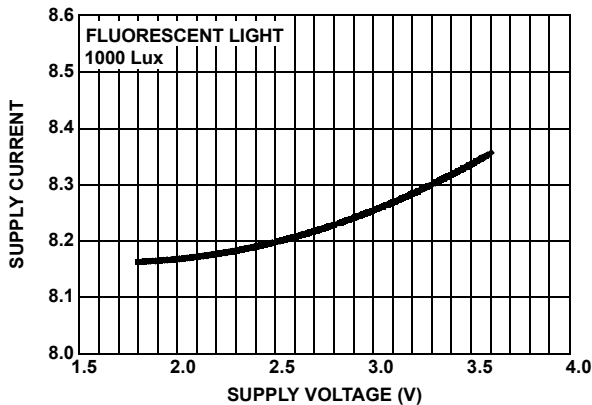

FIGURE 16. SUPPLY CURRENT vs SUPPLY VOLTAGE

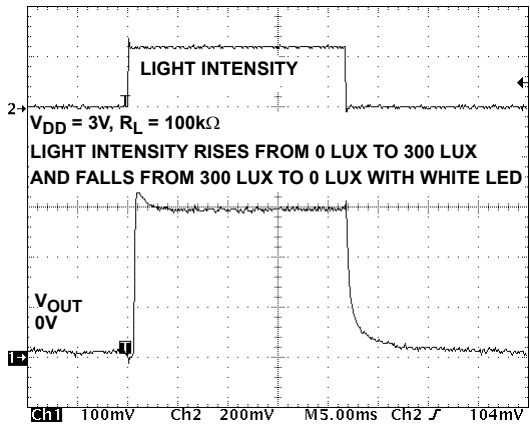

FIGURE 17. TRANSIENT RESPONSE OF ISL29009 TO CHANGE IN LIGHT INTENSITY

Application Information

Light-to-Current and Voltage Conversion

The ISL29009 has responsiveness that is a square-root function of the light intensity intercepted by the photodiode in lux. Because the photodiode has a responsivity that resembles the human eye, conversion rate is independent of the light source (fluorescent light, incandescent light or direct sunlight).

$$I_{OUT} = \frac{1.8\mu A}{\sqrt{100\text{lux}}} \sqrt{E} \quad (\text{EQ. 1})$$

Here, I_{OUT} is the output current in μA , and E is the input light in lux.

A load resistor R_L is added to convert I_{OUT} into V_{OUT} . The output voltage can be expressed in Equation 2:

$$V_{OUT} = I_{OUT} \times R_L = \frac{1.8\mu A}{\sqrt{100\text{lux}}} \sqrt{E} \times R_L \quad (\text{EQ. 2})$$

Here, V_{OUT} is the output voltage and R_L is the value of the load resistor added. The compliance of the ISL29009's output circuit may result in premature saturation of the output current and voltage when an excessively large R_L is used. The output compliance voltage is 200mV below the supply voltage as listed in V_{O-MAX} of the "Electrical Specifications" table on page 2.

Optical Sensor Location Outline

The green area in Figure 18 shows the optical sensor location outline of ISL29009. Along the pin-out direction, the center line (CL) of the sensor coincides with that of the packaging. The sensor width in this direction is 0.39mm. Perpendicular to the pin-out direction, the CL of the sensor has an 0.19mm offset from the CL of packaging away from pin-1. The sensor width in this direction is 0.46mm.

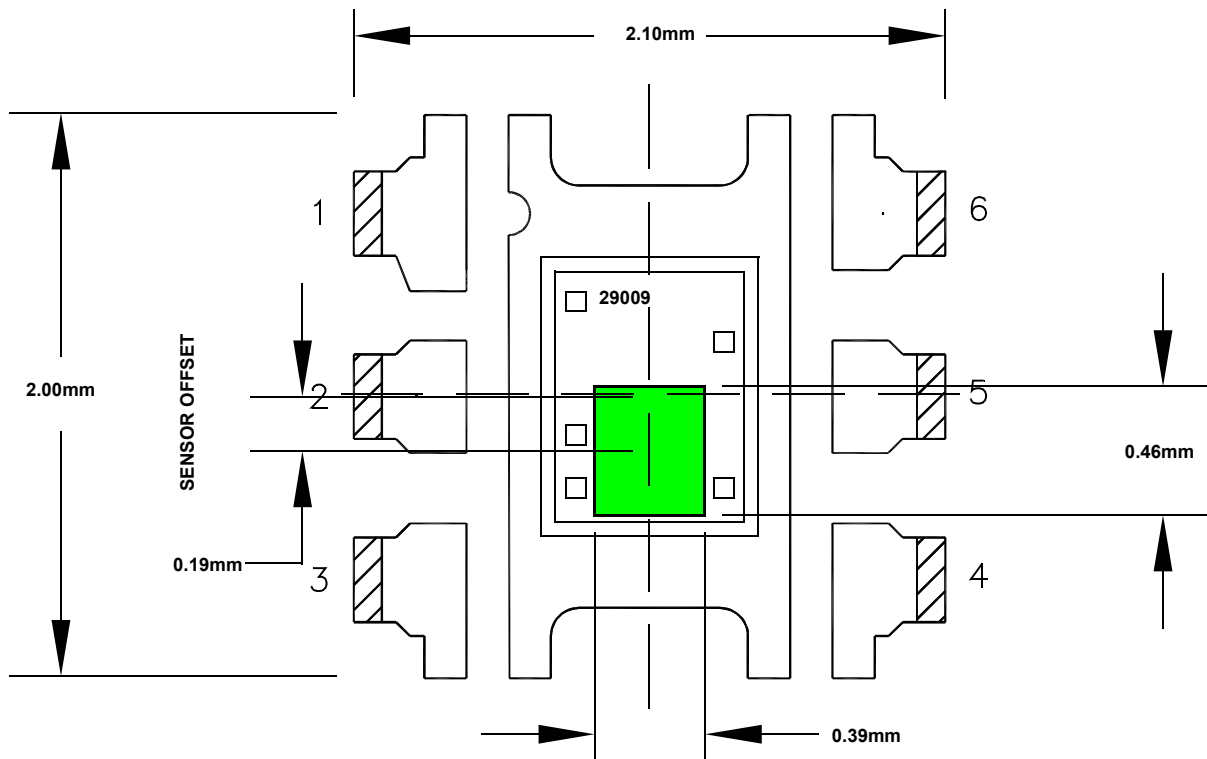

FIGURE 18. 6 LD ODFN SENSOR LOCATION OUTLINE

© Copyright Intersil Americas LLC 2008. All Rights Reserved.

All trademarks and registered trademarks are the property of their respective owners.

For additional products, see www.intersil.com/en/products.html

Intersil products are manufactured, assembled and tested utilizing ISO9001 quality systems as noted in the quality certifications found at www.intersil.com/en/support/qualandreliability.html

Intersil products are sold by description only. Intersil may modify the circuit design and/or specifications of products at any time without notice, provided that such modification does not, in Intersil's sole judgment, affect the form, fit or function of the product. Accordingly, the reader is cautioned to verify that datasheets are current before placing orders. Information furnished by Intersil is believed to be accurate and reliable. However, no responsibility is assumed by Intersil or its subsidiaries for its use; nor for any infringements of patents or other rights of third parties which may result from its use. No license is granted by implication or otherwise under any patent or patent rights of Intersil or its subsidiaries.

For information regarding Intersil Corporation and its products, see www.intersil.com

Package Outline Drawing

L6.2x2.1

6 LEAD OPTICAL DUAL FLAT NO-LEAD PLASTIC PACKAGE (ODFN)

Rev 0, 9/06

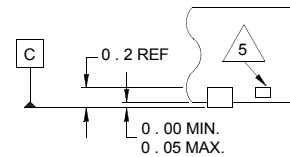
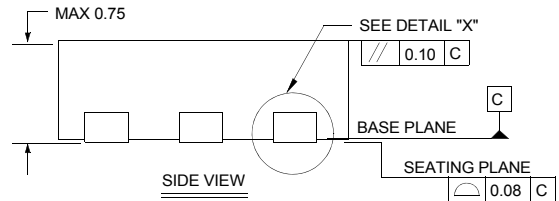
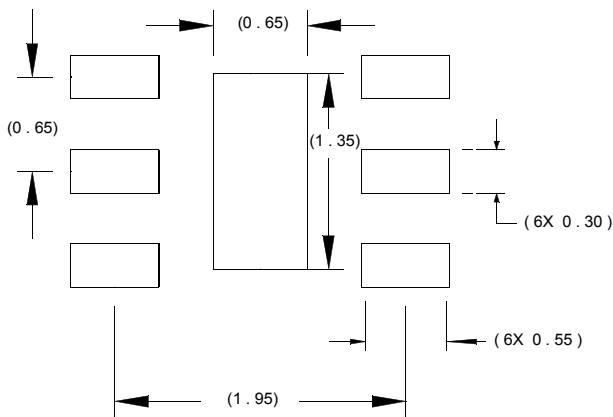
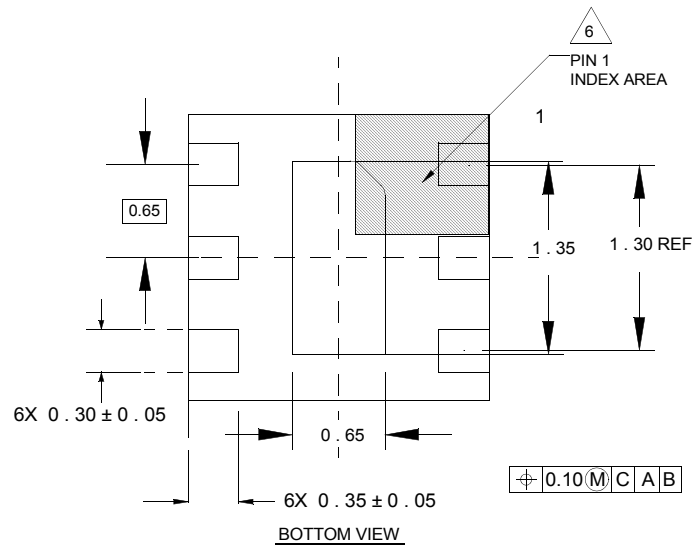
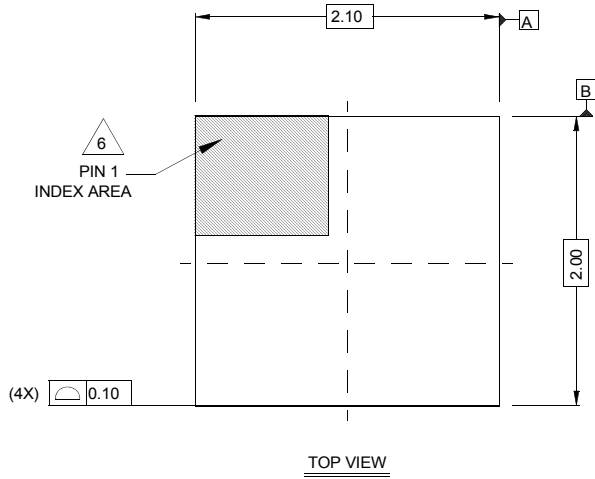

NOTES:

1. Dimensions are in millimeters.
Dimensions in () for Reference Only.
2. Dimensioning and tolerancing conform to AMSE Y14.5m-1994.
3. Unless otherwise specified, tolerance : Decimal ± 0.05
4. Dimension b applies to the metallized terminal and is measured between 0.15mm and 0.30mm from the terminal tip.
5. Tiebar shown (if present) is a non-functional feature.
6. The configuration of the pin #1 identifier is optional, but must be located within the zone indicated. The pin #1 identifier may be either a mold or mark feature.

Looking for pricing, stock, or lifecycle information?

Click below to explore more details on WIN SOURCE:

-  [View ISL29009IROZ-T7 on WIN SOURCE](#)
-  [Renesas Electronics America](#) Information

Optimize Your Supply Chain with WIN SOURCE Solutions

-  Global Sourcing Solution
-  Obsolete Management
-  Cost Control Management
-  Shortage Management
-  Alternative Solution
-  Excess Inventory Management