

Motor Drivers for Digital Still Cameras

7-Channel System Lens Driver for Digital Still Cameras

BD6889GU
General Description

The BD6889GU is a motor driver that integrates 6 Full-ON type H-Bridges and 1 Linear Constant-Current type H-Bridge. The device is intended to drive three stepping motor for auto focus system, zoom, and iris, and making it possible to design a sophisticated, high precision lens drive system.

Features

- Low ON-Resistance Power CMOS Output
- 4 Digital NPN Transistor Circuits for Rectangular Waveform of Photo-Interrupter: Input-Dividing Type with Output Pull-up Resistor
- 4 Digital PNP Transistor Circuits for Rectangular Waveform of Photo-Interrupter: Input-Dividing Type with Output Pull-down Resistor
- Voltage-Regulator Circuit for Photo-Interrupter
- High-Precision (0.9V±2%) Reference Voltage Output
- Phase Compensation Capacitor-Free Design for Linear Constant-Current Drive Block
- High-Precision (±3%) Linear Constant-Current Driver
- Under Voltage Locked Out Protection & Thermal Shut Down Circuit

Applications

- Mobile system
- Home appliance
- Amusement system, etc

Key Specifications

- Power Supply Voltage Range: 2.5V to 5.7V
- Motor Power Supply Voltage Range: 2.5V to 5.7V
- Circuit Current (No Signal): 1.5mA(Typ)
- Stand-By Current: 10µA (Max)
- Control Input Voltage Range: 0V to V_{CC}V
- H-Bridge Output Current: -0.5A/ch to +0.5A/ch
- Output ON-Resistance (Channel 1 to 6): 1.3Ω(Typ)
- Output ON-Resistance (Channel 7): 0.9Ω(Typ)
- Operating Temperature Range: -25°C to +85°C

Package

VBGA063T050

W(Typ) x D(Typ) x H(Max)

5.00mm x 5.00mm x 1.20mm

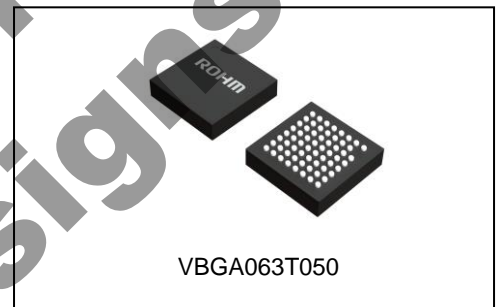

Typical Application Circuit

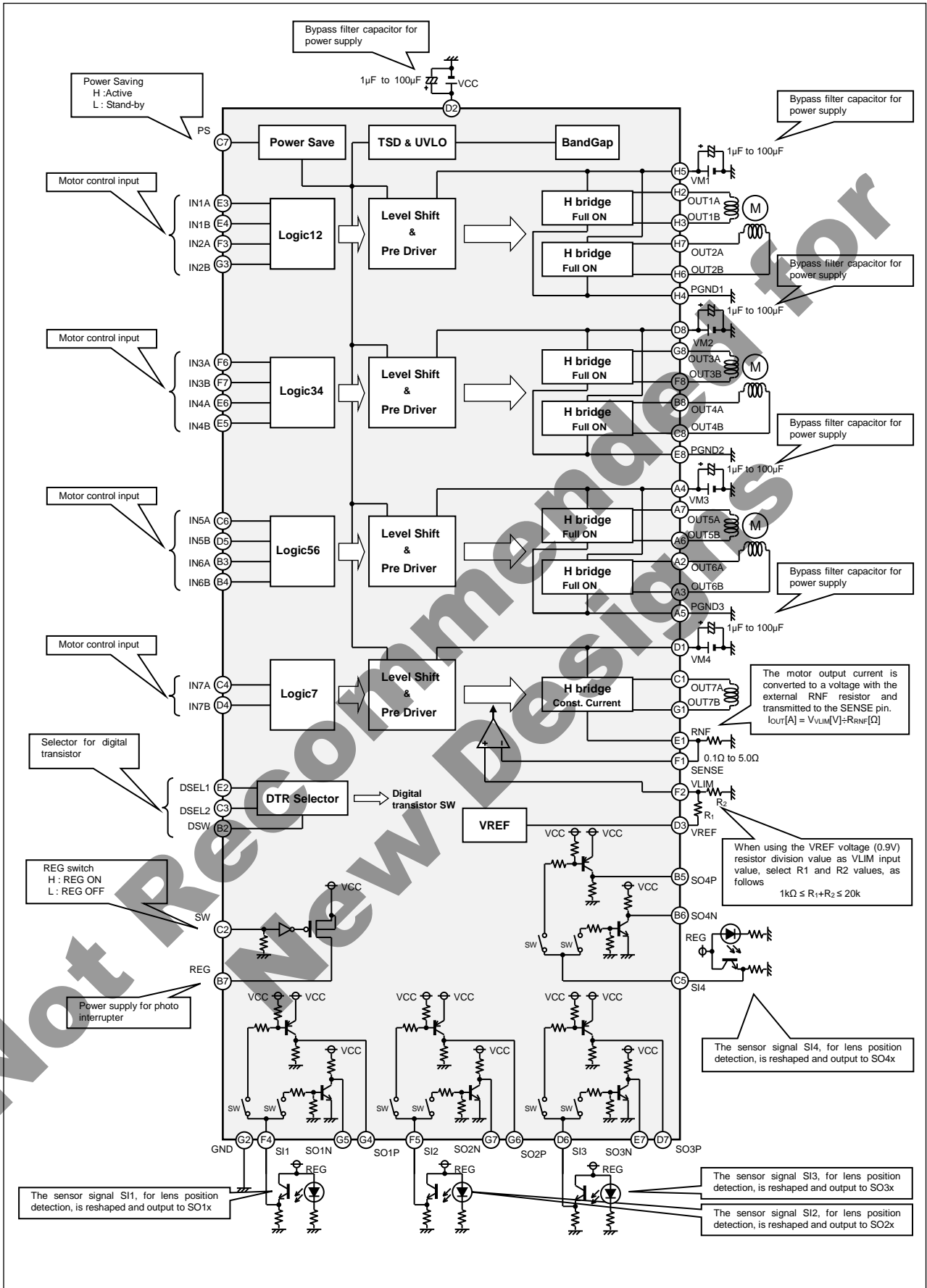

Pin Configurations

(TOP VIEW)

	1	2	3	4	5	6	7	8
A	N.C.	OUT6A	OUT6B	VM3	PGND3	OUT5B	OUT5A	N.C.
B	INDEX POST	DSW	IN6A	IN6B	SO4P	SO4N	REG	OUT4A
C	OUT7A	SW	DSEL2	IN7A	SI4	IN5A	PS	OUT4B
D	VM4	VCC	VREF	IN7B	IN5B	SI3	SO3P	VM2
E	RNF	DSEL1	IN1A	IN1B	IN4B	IN4A	SO3N	PGND2
F	SENSE	VLIM	IN2A	SI1	SI2	IN3A	IN3B	OUT3B
G	OUT7B	GND	IN2B	SO1P	SO1N	SO2P	SO2N	OUT3A
H	N.C.	OUT1A	OUT1B	PGND1	VM1	OUT2B	OUT2A	N.C.

Pin Descriptions

Pin No.	Pin Name	Function	Pin No.	Pin Name	Function
A1	N.C.	-	E1	RNF	Current detect resistor ch.7
A2	OUT6A	H-bridge output 6A	E2	DSEL1	Selector for transistor output 1
A3	OUT6B	H-bridge output 6B	E3	IN1A	Control logic input 1A
A4	VM3	Motor power supply ch.5, ch.6	E4	IN1B	Control logic input 1B
A5	PGND3	Motor ground ch.5, ch.6	E5	IN4B	Control logic input 4B
A6	OUT5B	H-bridge output 5B	E6	IN4A	Control logic input 4A
A7	OUT5A	H-bridge output 5A	E7	SO3N	NPN transistor output 3
A8	N.C.	-	E8	PGND2	Motor ground ch.3 & ch.4
B1	INDEX POST		F1	SENSE	Output current detection ch.7
B2	DSW	Enable for transistors	F2	VLIM	Output current setting ch.7
B3	IN6A	Control logic input 6A	F3	IN2A	Control logic input 2A
B4	IN6B	Control logic input 6B	F4	SI1	Digital transistor input 1
B5	SO4P	PNP transistor output 4	F5	SI2	Digital transistor input 2
B6	SO4N	NPN transistor output 4	F6	IN3A	Control logic input 3A
B7	REG	Regulator output for PI	F7	IN3B	Control logic input 3B
B8	OUT4A	H-bridge output 4A	F8	OUT3B	H-bridge output 3B
C1	OUT7A	H-bridge output 7A	G1	OUT7B	H-bridge output 7B
C2	SW	Regulator input	G2	GND	Device ground
C3	DSEL2	Selector for transistor output 2	G3	IN2B	Control logic input 2B
C4	IN7A	Control logic input 7A	G4	SO1P	PNP transistor output 1
C5	SI4	Digital transistor input 4	G5	SO1N	NPN transistor output 1
C6	IN5A	Control logic input 5A	G6	SO2P	PNP transistor output 2
C7	PS	Power-saving	G7	SO2N	NPN transistor output 2
C8	OUT4B	H-bridge output 4B	G8	OUT3A	H-bridge output 3A
D1	VM4	Motor power supply ch.7	H1	N.C.	-
D2	VCC	Power supply	H2	OUT1A	H-bridge output 1A
D3	VREF	Reference voltage output	H3	OUT1B	H-bridge output 1B
D4	IN7B	Control logic input 7B	H4	PGND1	Motor ground ch.1, ch.2
D5	IN5B	Control logic input 5B	H5	VM1	Motor power supply ch.1, ch.2
D6	SI3	Digital transistor input 3	H6	OUT2B	H-bridge output 2B
D7	SO3P	PNP transistor output 3	H7	OUT2A	H-bridge output 2A
D8	VM2	Motor power supply ch.3, ch.4	H8	N.C.	-

Block Diagram

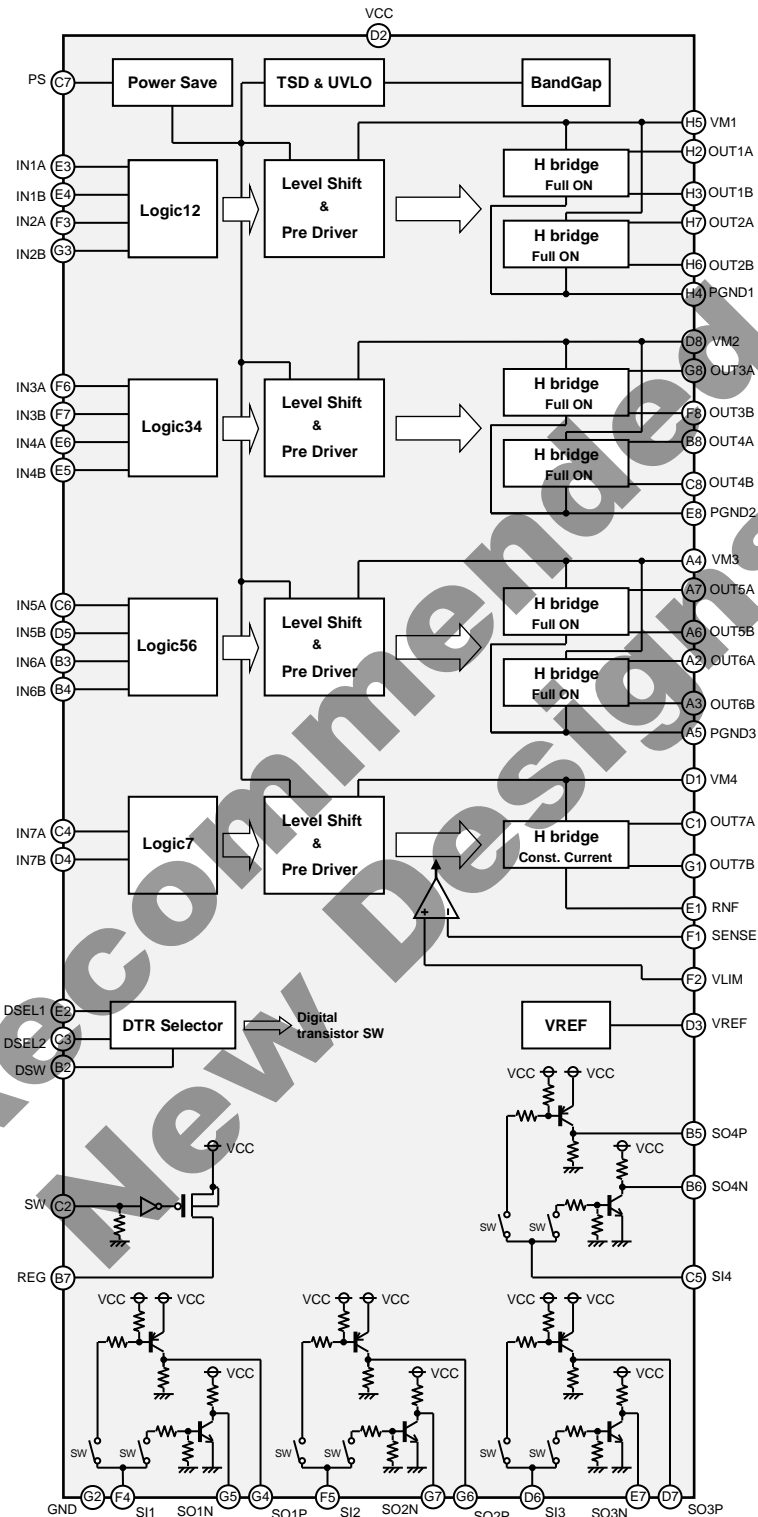

Description of Blocks

1. Power-Saving Function
A power-saving function is included, which allows the system to save power when not driving the motor. The voltage level on this pin should be set high so as to keep the operation mode. (See the Electrical Characteristics; P.7/17)
2. Motor Control Input (IN1A to IN7B)
Logic level controls the output logic of H-Bridge. The logic of Full-ON H-Bridges corresponds to IN/IN mode, and the logic of Constant-Current H-bridge EN/IN mode.
(See the Electrical Characteristics; P.7/17, and I/O Truth Table; P.9/17)
3. H-Bridge
Each H-bridge can be controlled independently. It is therefore possible to drive the H-bridges simultaneously, as long as the package thermal tolerances are not exceeded. Because the respective output transistors consist of power CMOS which consumes a motor power supply V_M , the ON-Resistance value of high and low-side total is dependent on V_M voltage. Further, the whole application must be designed so that the maximum current of each channel may be 500mA or below. (See the Recommended Operating Conditions; p.6/17)
4. Linear Constant-Current H-bridge (Channel 7)
 - (a) Reference Voltage Output (with a tolerance of $\pm 2\%$)
The VREF pin can output 0.9V based on the internal reference voltage. The output current of the Constant-Current Drive block can be controlled by connecting external resistor to the VREF pin and setting the voltage which is divided by the resistor to the output current setting pin (VLIM pin). It is recommended to place the external 1k Ω or above resistor in consideration of the load current capacity of the VREF pin, and to place the 20k Ω or below resistor in order to minimize the fluctuation caused by the base current of the internal transistor.
 - (b) Output Current Detection and Current Settings
A low-value (0.1 Ω to 5.0 Ω) resistor can be placed between the RNF pin and ground to detect the motor winding current. When making the RNF and SENSE pins short-circuit, the internal circuits can output the accurate constant current by comparing the VLIM voltage with detecting voltage. To make more accurate motor winding current, trim the external RNF resistor, and supply VLIM pin with another precise external voltage. In case of this condition, VREF pin should be kept open.

$$\text{Output Current } I_{out}[A] = \text{VLIM}[V] / \text{RNF}[\Omega]$$

The motor winding current will be 400mA $\pm 3\%$, if 0.2V is set to the VLIM pin and a 0.5 Ω external resistor is connected to the RNF pin. If the VLIM pin is shorted to the VCC pin (or the same voltage as the V_{CC} is set) and the SENSE and RNF pins are shorted to the ground, this channel can drive as a Full-ON type H-bridge like other channels.

5. Digital Transistor for Rectangular Waveform
The internal 4 NPN and 4 PNP digital transistors can be used to make photo-interrupter waveform rectangular. To detect lens position, the sensed signal is reshaped by internal circuitry and then may be output to the MCU etc. The device includes pull-up resistors for each NPN output pin (SO1N to SO4N) and pull-down resistors for each PNP output pin (SO1P to SO4P). If not supplying an external voltage to input pins (SI1 to SI4), the NPN output pins will output V_{CC} voltage and the PNP output pins ground. DSW, DSEL1 and DSEL2 pins can control the switching of NPN and PNP transistors. (See I/O Truth Table; P.9/17)
6. Voltage-Regulator for Photo-Interrupter
The device includes voltage-regulator circuits for photo-interrupter. Set high logic on SW pin to enable output of the internal regulator, and set low to disable. It also includes a pull-down resistor so that regulator output (REG pin) may be off even if SW pin is opened.

Absolute Maximum Ratings (Ta=25°C)

Parameter	Symbol	Limit	Unit
Power Supply Voltage	V _{CC}	-0.5 to +7.0	V
Motor Power Supply Voltage	V _M	-0.5 to +7.0	V
Control Input Voltage	V _{IN}	-0.5 to +V _{CC} +0.5	V
Power Dissipation	P _d	0.98 (Note 1)	W
H-bridge Output Current	I _{OUT}	-0.8 to +0.8 (Note 2)	A/ch
Storage Temperature Range	T _{stg}	-55 to +150	°C
Junction Temperature	T _{jmax}	150	°C

(Note 1) Reduced by 7.84mW/°C over 25°C, when mounted on a glass epoxy board (70mm x 70mm x 1.6mm)

(Note 2) Must not exceed P_d, A_{SO}, or T_{jmax} of 150°C

Caution: Operating the IC over the absolute maximum ratings may damage the IC. The damage can either be a short circuit between pins or an open circuit between pins and the internal circuitry. Therefore, it is important to consider circuit protection measures, such as adding a fuse, in case the IC is operated over the absolute maximum ratings.

Recommended Operating Conditions

Parameter	Symbol	Min	Typ	Max	Unit
Power Supply Voltage	V _{CC}	2.5	-	5.7	V
Motor Power Supply Voltage	V _M	2.5	-	5.7	V
Control Input Voltage	V _{IN}	0	-	V _{CC}	V
H-bridge Output Current ^(Note 3)	I _{OUT}	-0.5	-	+0.5	A/ch
Operating Temperature Range	T _{opr}	-25	-	+85	°C

(Note 3) Must not exceed P_d, A_{SO}, or T_{jmax} of 150°C

Electrical Characteristics (Unless otherwise specified $V_{CC}=3.0V$, $V_M=5.0V$, $T_a=25^\circ C$)

Parameter	Symbol	Min	Typ	Max	Unit	Conditions
All Circuits						
Stand-by Current	I_{CCST}	-	0	10	μA	$V_{PS}=0V$
Circuit Current	I_{CC}	-	1.5	3.0	mA	$V_{PS}=3V$, with no signal
Control Input (IN=PS, IN1A to IN7B, SW, DSW, DSEL1, DSEL2)						
High Level Input Voltage	V_{INH}	2.0	-	V_{CC}	V	
Low Level Input Voltage	V_{INL}	0	-	0.7	V	
High Level Input Current	I_{INH}	15	30	60	μA	$V_{IN}=3V$
Low Level Input Current	I_{INL}	-1	0	-	μA	$V_{IN}=0V$
Pull-down Resistor	R_{IN}	50	100	200	k Ω	
Under Voltage Locked Out (UVLO)						
UVLO Voltage	V_{UVLO}	1.6	-	2.4	V	
Full-ON Drive Block (Channel 1 to Channel 6)						
Output ON-Resistance	R_{ON}	-	1.3	1.6	Ω	$I_{OUT}=\pm 400mA$, High & Low-side total
Pulse Input Response	t_P	100	-	-	ns	With an input pulse 200ns
Linear Constant-Current Drive Block (Channel 7)						
Output ON-Resistance	R_{ON}	-	0.9	1.1	Ω	$I_{OUT}=\pm 400mA$, High & Low-side total
VREF Output Voltage	V_{REF}	0.88	0.90	0.92	V	$I_{OUT}=0$ to 1mA
Output Limit Current 1	I_{OL1}	388	400	412	mA	10 Ω load, $R_{RNF}=0.5\Omega$, $V_{VLIM}=0.20V$
Output Limit Current 2	I_{OL2}	285	300	315	mA	10 Ω load, $R_{RNF}=0.5\Omega$, $V_{VLIM}=0.15V$
Output Limit Current 3	I_{OL3}	190	200	210	mA	10 Ω load, $R_{RNF}=0.5\Omega$, $V_{VLIM}=0.10V$
Digital NPN Transistor Block for Rectangular Waveform of Photo-Interrupter						
Input Current	I_{SIH}	-	-	0.1	mA	$V_{SIX}=3V$
Low Level Output Voltage	V_{SOL}	-	0.1	0.25	V	$V_{SIX}=3V$, $I_{SO}=0.5mA$
Input Dividing Resistor	R_{SIN}	70	100	130	k Ω	
Output Pull-up Resistor	R_{SOH}	23	33	43	k Ω	
Input Dividing Resistors Comparison	-	0.8	1.0	1.2	-	Comparison of dividing resistors between S_{IX} and GND (Note 4)
Digital PNP Transistor Block for Rectangular Waveform of Photo-Interrupter						
Input Current	I_{SIL}	-0.1	-	-	mA	$V_{SIX}=0V$
High Level Output Voltage	V_{SOH}	$V_{CC}-0.25$	$V_{CC}-0.1$	-	V	$V_{SIX}=0V$, $I_{SO}=-0.5mA$
Input Dividing Resistor	R_{SIP}	70	100	130	k Ω	
Output Pull-down Resistor	R_{SOL}	23	33	43	k Ω	
Input Dividing Resistors Comparison	-	0.8	1.0	1.2	-	Comparison of dividing resistors between S_{IX} and VCC (Note 4)
Voltage-regulator for Photo-Interrupter						
High Level Output Voltage	V_{REGH}	$V_{CC}-0.25$	$V_{CC}-0.2$	-	V	$I_{REG}=100mA$
Output ON-Resistance	R_{ONREG}	-	2	2.5	Ω	$I_{REG}=100mA$
Output Leak Current	I_{LPI}	-	0	1	μA	SW=VCC

(Note 4) Not guaranteed by testing

Typical Performance Curves

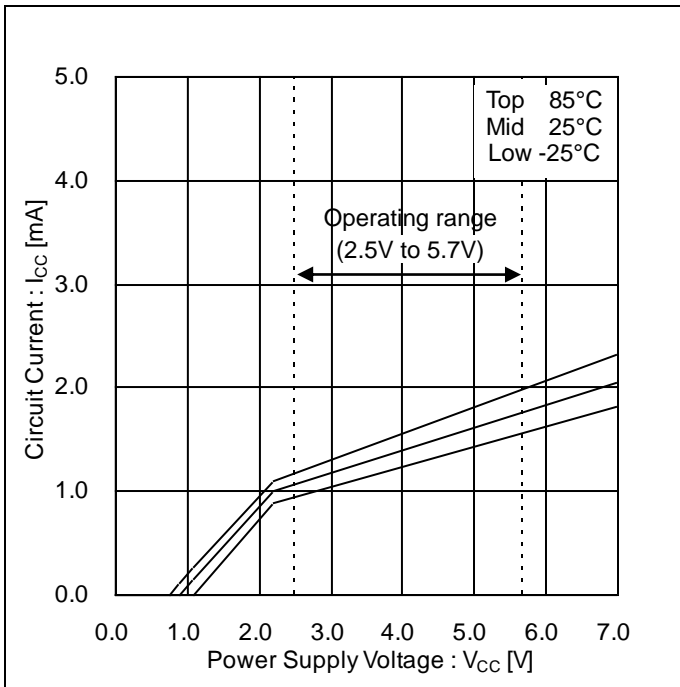

Figure 1.
Circuit Current vs Power Supply Voltage

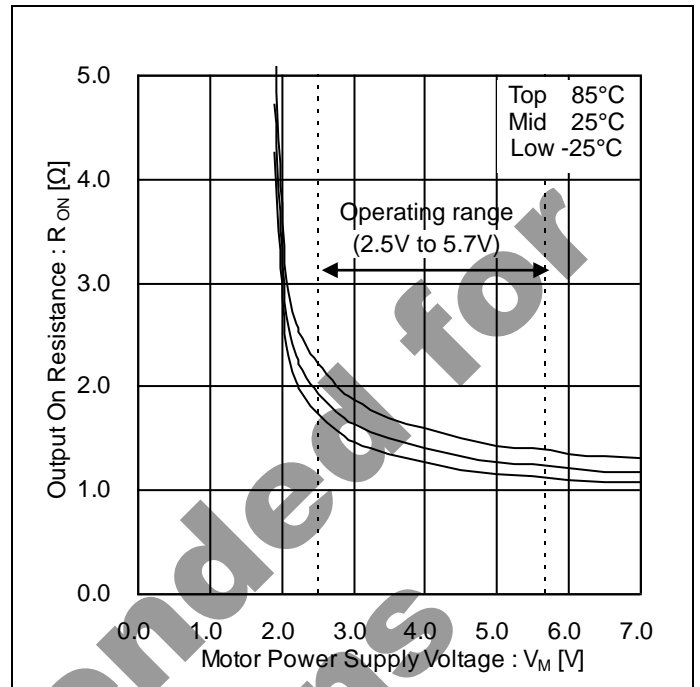

Figure 2.
Output ON-Resistance vs Motor Power Supply Voltage
(Channel 1 to Channel 6, Vcc=3V)

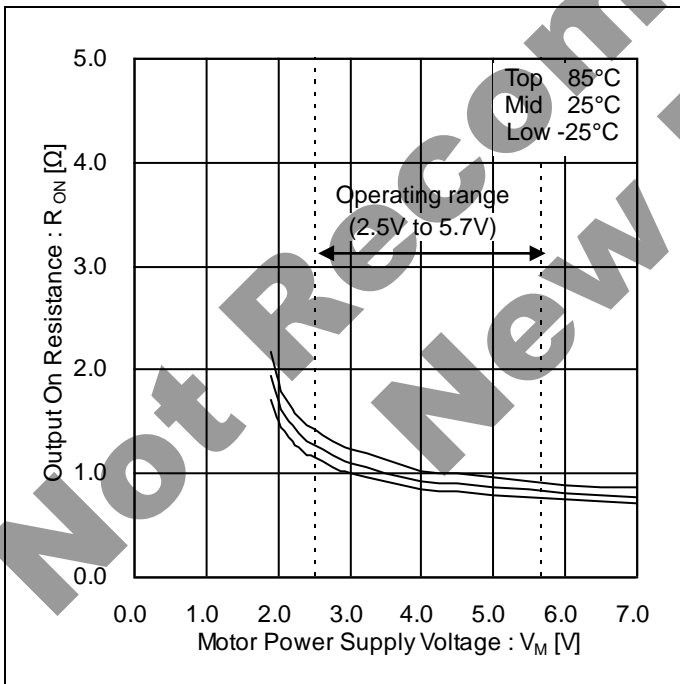

Figure 3.
Output ON-Resistance vs Motor Power Supply Voltage
(Channel 7, Vcc=3V)

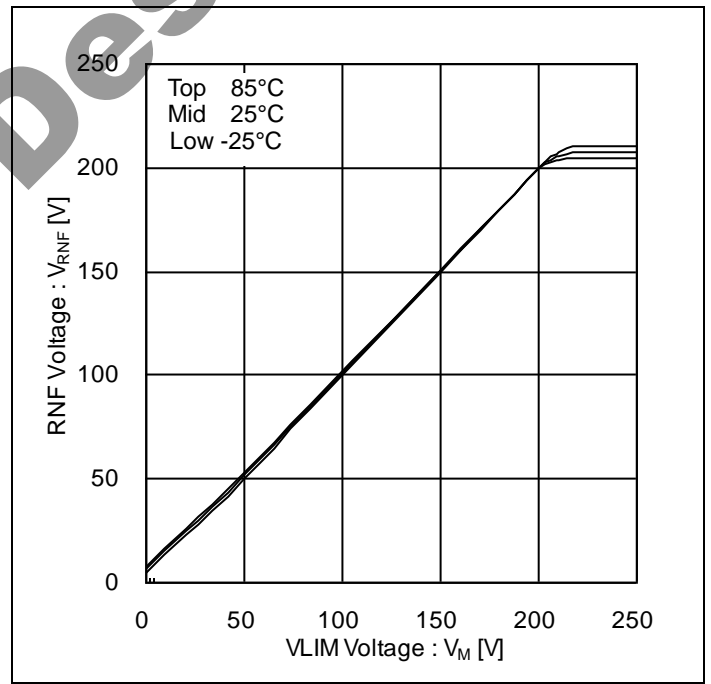

Figure 4.
RNF Voltage vs VLIM Voltage
(Output Limit Voltage, Rrnf=0.5Ω)

Timing chart

Table 1. I/O Truth Table (Channel 1 to Channel 6)

Input Mode	INPUT		OUTPUT		
	INxA	INxB	OUTxA	OUTxB	Output Mode ^(Note 5)
IN/IN	L	L	Z	Z	Open
	H	L	H	L	CW
	L	H	L	H	CCW
	H	H	L	L	Short Brake

L: Low, H: High, X: Don't care, Z: Hi impedance

(Note 5) CW: Current flows from OUTxA to OUTxB, CCW: Current flows from OUTxB to OUTxA (x=1 to 6)

Table 2. I/O Truth Table (Channel 7)

Input Mode	INPUT		OUTPUT		
	IN7A	IN7B	OUT7A	OUT7B	Output Mode ^(Note 6)
EN/IN	L	X	Z	Z	Open
	H	L	H	L	CW
	H	H	L	H	CCW

L: Low, H: High, X: Don't care, Z: Hi impedance

(Note 6) CW: Current flows from OUT7A to OUT7B, CCW: Current flows from OUT7B to OUT7A

Table 3. Digital Transistor I/O Truth Table

	INPUT			OUTPUT							
	DSW	DSEL1	DSEL2	PNP1	NPN1	PNP2	NPN2	PNP3	NPN3	PNP4	NPN4
LOGIC	L	X	X	OFF	OFF	OFF	OFF	OFF	OFF	OFF	OFF
	H	L	L	OFF	ON	OFF	ON	OFF	ON	OFF	ON
	H	L	H	OFF	ON	OFF	ON	ON	OFF	ON	OFF
	H	H	L	ON	OFF	ON	OFF	OFF	ON	OFF	ON
	H	H	H	ON	OFF	ON	OFF	ON	OFF	ON	OFF

L: Low, H: High, X: Don't care, OFF: GND (PNP), VCC (NPN)

PNPx can output to SOxP pins, NPNx can output to SOxN pins (x=1 to 4)

Timing chart – continued

Table 4. I/O Truth Table (In the case of 2phases driving the Stepping Motor by channel 1 and channel 2)

INPUT				OUTPUT				Output Mode (Note 7)
IN1A	IN1B	IN2A	IN2B	OUT1A	OUT1B	OUT2A	OUT2B	
L	L	L	L	Z	Z	Z	Z	Open
H	L	H	L	H	L	H	L	1. CW / CW
L	H	H	L	L	H	H	L	3. CCW / CW
L	H	L	H	L	H	L	H	5. CCW / CCW
H	L	L	H	H	L	L	H	7. CW / CCW

L: Low, H: High, X: Don't care, Z: Hi impedance

(Note 7) CW: Current flows from OUTxA to OUTxB, CCW: Current flows from OUTxB to OUTxA (x=1, 2)

Table 5. I/O Truth Table (In the case of 1-2 phases driving the Stepping Motor by channel 1 and channel 2)

INPUT				OUTPUT				出力モード ^(Note 8)
IN1A	IN1B	IN2A	IN2B	OUT1A	OUT1B	OUT2A	OUT2B	
L	L	L	L	Z	Z	Z	Z	Open / Open
H	L	H	L	H	L	H	L	1. CW / CW
L	L	H	L	Z	Z	H	L	2. Open / CW
L	H	H	L	L	H	H	L	3. CCW / CW
L	H	L	L	L	H	Z	Z	4. CCW / Open
L	H	L	H	L	H	L	H	5. CCW / CCW
L	L	L	H	Z	Z	L	H	6. Open / CCW
H	L	L	H	H	L	L	H	7. CW / CCW
H	L	L	L	H	L	Z	Z	8. CW / Open

L: Low, H: High, X: Don't care, Z: Hi impedance

(Note 8) CW: Current flows from OUTxA to OUTxB, CCW: Current flows from OUTxB to OUTxA (x=1, 2)

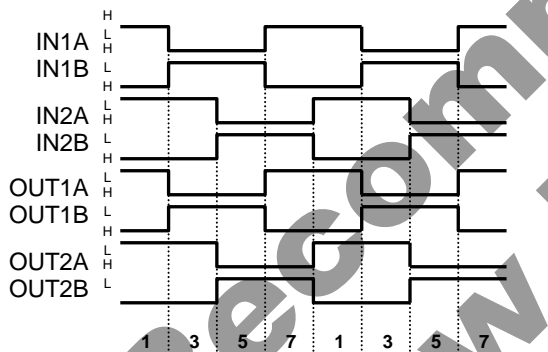

Figure 5. 2 Phases Timing Sequence with IN/IN Input

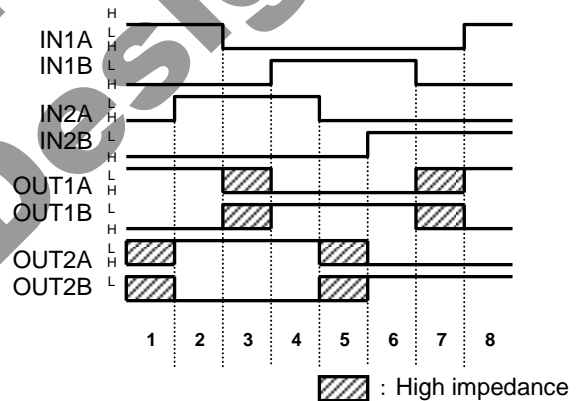

Figure 6. 1-2 Phases Timing Sequence with IN/IN Input

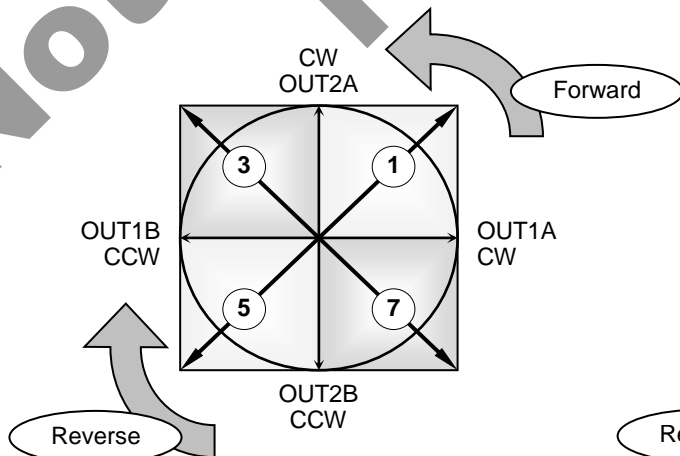

Figure 7. Torque Vector of 2 Phases Mode

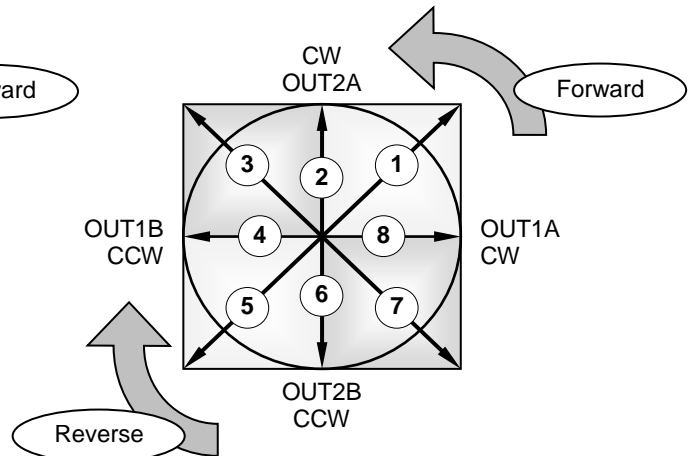
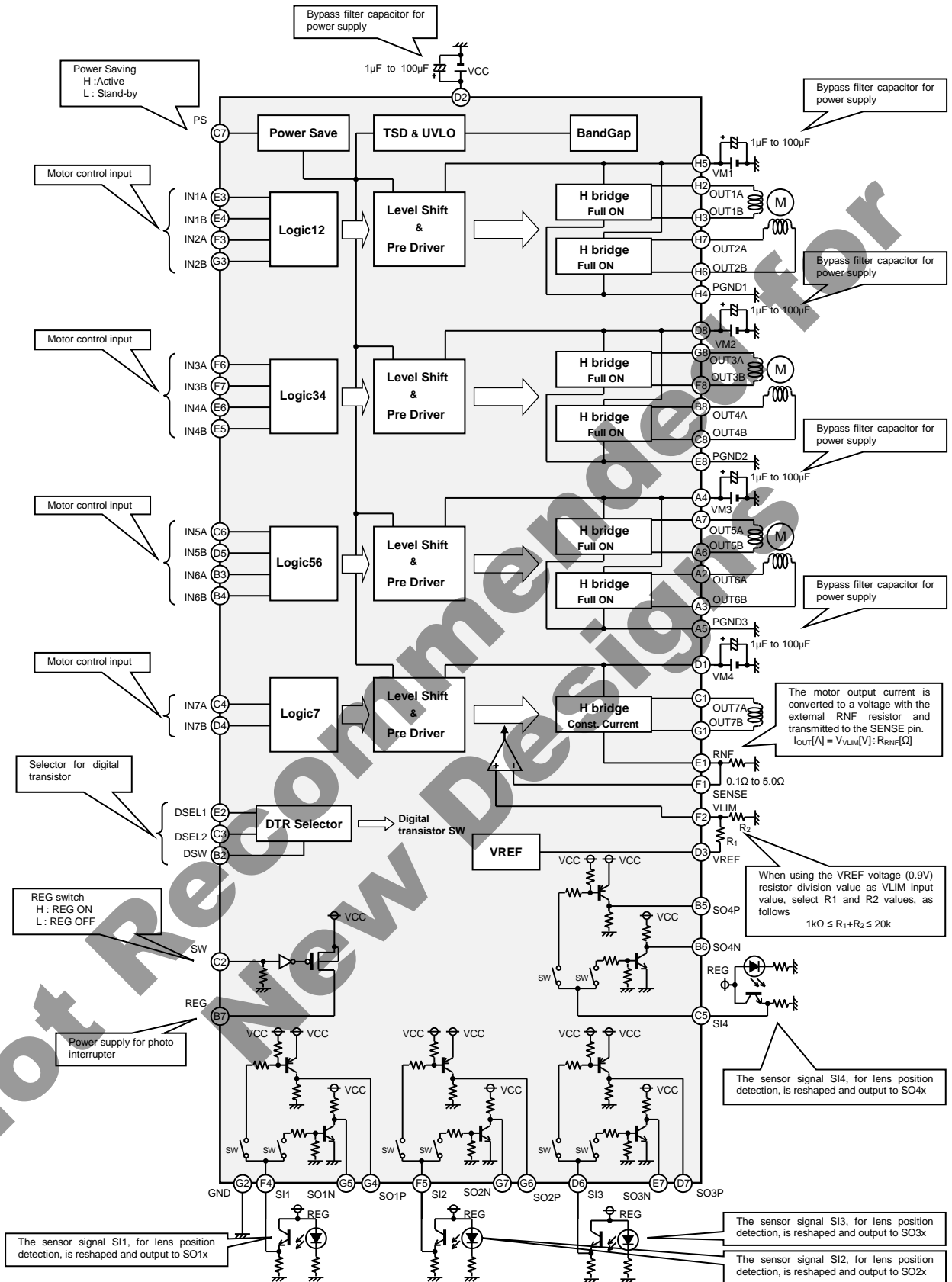

Figure 8. Torque Vector of 1-2 Phases Mode

Application Example



Selection of Components Externally Connected

When using the circuit with changes to the external circuit constants, make sure to leave an adequate margin for external components including static and transitional characteristics as well as dispersion of the IC.

Power Dissipation

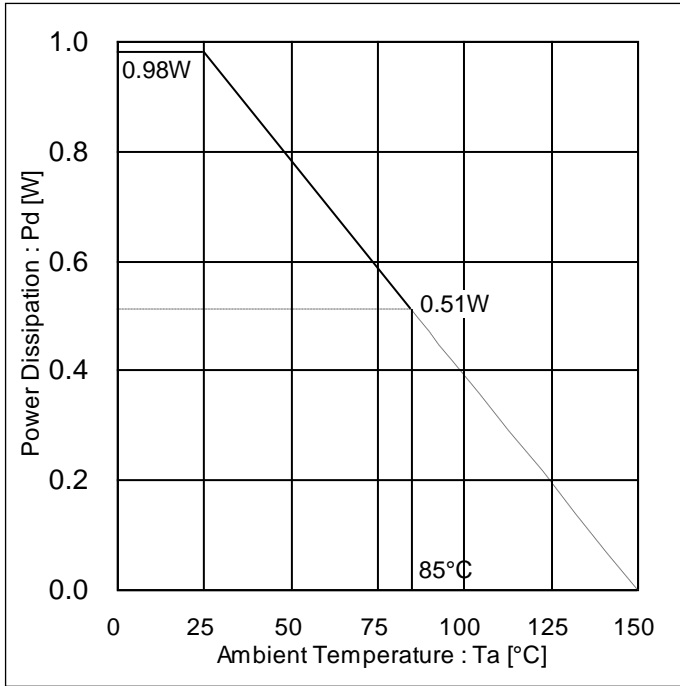

Figure 9. Power Dissipation vs Ambient Temperature

I/O Equivalent Circuits

<p>PS, IN1A to IN7B, SW, DSW, DSEL1, DSEL2</p>	<p>VMx, OUTxA, OUTxB, PGNDx, RNF</p>	<p>VREF</p>
<p>SI1 to SI4</p>	<p>VLIM, SENSE</p>	<p>REG</p>
	<p>SO1N to SO4N</p>	<p>SO1P to SO4P</p>

Operational Notes

1. Reverse Connection of Power Supply

Connecting the power supply in reverse polarity can damage the IC. Take precautions against reverse polarity when connecting the power supply, such as mounting an external diode between the power supply and the IC's power supply pins.

2. Power Supply Lines

Design the PCB layout pattern to provide low impedance supply lines. Separate the ground and supply lines of the digital and analog blocks to prevent noise in the ground and supply lines of the digital block from affecting the analog block. Furthermore, connect a capacitor to ground at all power supply pins. Consider the effect of temperature and aging on the capacitance value when using electrolytic capacitors.

3. Ground Voltage

Ensure that no pins are at a voltage below that of the ground pin at any time, even during transient condition.

4. Ground Wiring Pattern

When using both small-signal(GND) and large-current ground(PGND) traces, the two ground traces should be routed separately but connected to a single ground at the reference point of the application board to avoid fluctuations in the small-signal ground caused by large currents. Also ensure that the ground traces of external components do not cause variations on the ground voltage. The ground lines must be as short and thick as possible to reduce line impedance.

5. Thermal Consideration

Should by any chance the power dissipation rating be exceeded the rise in temperature of the chip may result in deterioration of the properties of the chip. In case of exceeding this absolute maximum rating, increase the board size and copper area to prevent exceeding the Pd rating.

6. Recommended Operating Conditions

These conditions represent a range within which the expected characteristics of the IC can be approximately obtained. The electrical characteristics are guaranteed under the conditions of each parameter.

7. Inrush Current

When power is first supplied to the IC, it is possible that the internal logic may be unstable and inrush current may flow instantaneously due to the internal powering sequence and delays, especially if the IC has more than one power supply. Therefore, give special consideration to power coupling capacitance, power wiring, width of ground wiring, and routing of connections.

8. Operation Under Strong Electromagnetic Field

Operating the IC in the presence of a strong electromagnetic field may cause the IC to malfunction.

9. Testing on Application Boards

When testing the IC on an application board, connecting a capacitor directly to a low-impedance output pin may subject the IC to stress. Always discharge capacitors completely after each process or step. The IC's power supply should always be turned off completely before connecting or removing it from the test setup during the inspection process. To prevent damage from static discharge, ground the IC during assembly and use similar precautions during transport and storage.

10. Inter-pin Short and Mounting Errors

Ensure that the direction and position are correct when mounting the IC on the PCB. Incorrect mounting may result in damaging the IC. Avoid nearby pins being shorted to each other especially to ground, power supply and output pin. Inter-pin shorts could be due to many reasons such as metal particles, water droplets (in very humid environment) and unintentional solder bridge deposited in between pins during assembly to name a few.

11. Unused Input Pins

Input pins of an IC are often connected to the gate of a MOS transistor. The gate has extremely high impedance and extremely low capacitance. If left unconnected, the electric field from the outside can easily charge it. The small charge acquired in this way is enough to produce a significant effect on the conduction through the transistor and cause unexpected operation of the IC. So unless otherwise specified, unused input pins should be connected to the power supply or ground line.

Operational Notes – continued

12. Regarding the Input Pin of the IC

This monolithic IC contains P+ isolation and P substrate layers between adjacent elements in order to keep them isolated. P-N junctions are formed at the intersection of the P layers with the N layers of other elements, creating a parasitic diode or transistor. For example (refer to figure below):

When $GND > Pin A$ and $GND > Pin B$, the P-N junction operates as a parasitic diode.

When $GND > Pin B$, the P-N junction operates as a parasitic transistor.

Parasitic diodes inevitably occur in the structure of the IC. The operation of parasitic diodes can result in mutual interference among circuits, operational faults, or physical damage. Therefore, conditions that cause these diodes to operate, such as applying a voltage lower than the GND voltage to an input pin (and thus to the P substrate) should be avoided.

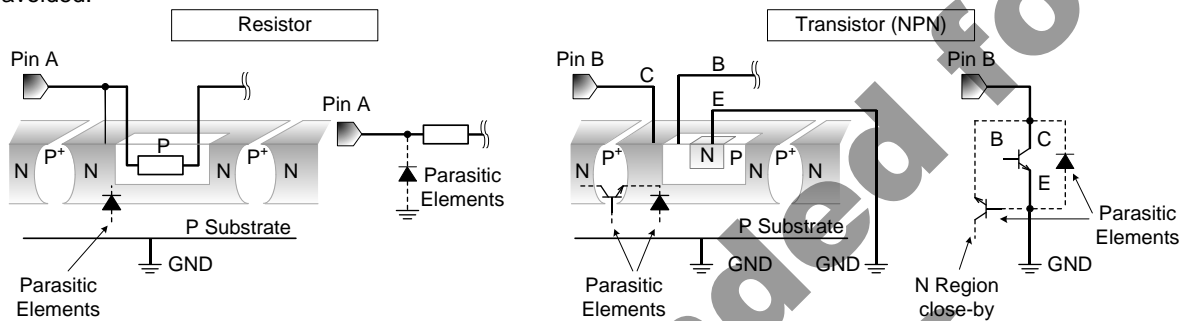

Figure 10.
Example of monolithic IC structure

13. Ceramic Capacitor

When using a ceramic capacitor, determine the dielectric constant considering the change of capacitance with temperature and the decrease in nominal capacitance due to DC bias and others.

14. Area of Safe Operation (ASO)

Operate the IC such that the output voltage, output current, and power dissipation are all within the Area of Safe Operation (ASO).

15. Thermal Shutdown Circuit(TSD)

This IC has a built-in thermal shutdown circuit that prevents heat damage to the IC. Normal operation should always be within the IC's power dissipation rating. If however the rating is exceeded for a continued period, the junction temperature (T_j) will rise which will activate the TSD circuit that will turn OFF all output pins. When the T_j falls below the TSD threshold, the circuits are automatically restored to normal operation.

Note that the TSD circuit operates in a situation that exceeds the absolute maximum ratings and therefore, under no circumstances, should the TSD circuit be used in a set design or for any purpose other than protecting the IC from heat damage.

Ordering Information

B D 6 8 8 9 G U	-	E 2
Part Number	Package GU: VBGA063T050	Packaging and forming specification E2: Embossed tape and reel

Marking Diagram

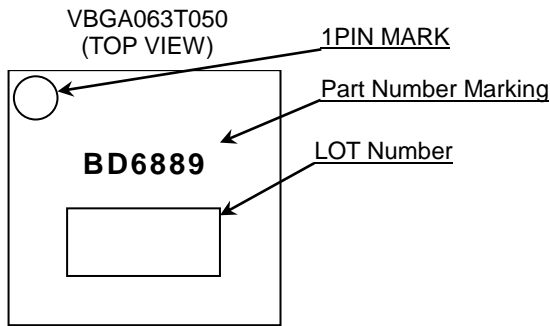

Part Number Marking	Package	Orderable Part Number
BD6889	VBGA063T050	BD6889GU-E2

Not Recommended for New Designs

Physical Dimension Tape and Reel Information

Package Name	VBGA063T050
--------------	-------------

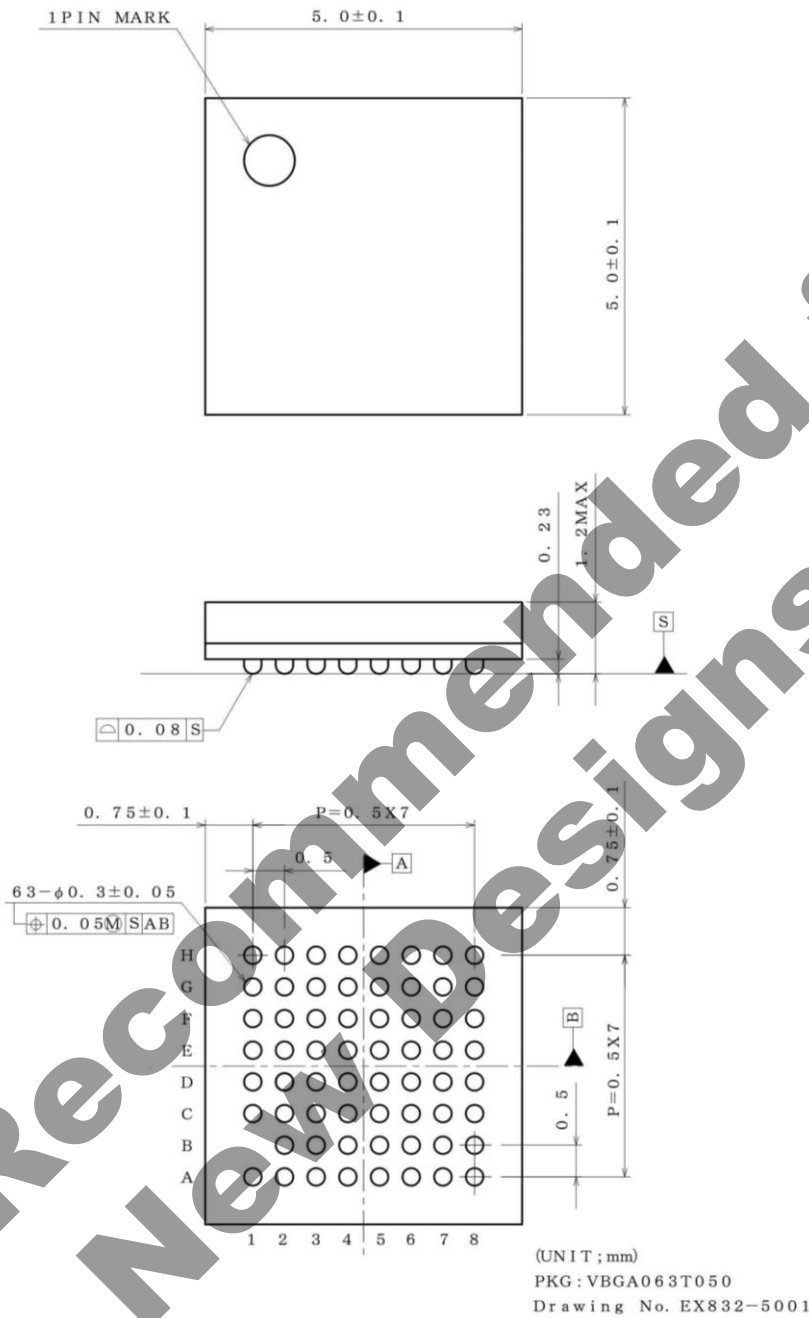

<Tape and Reel information>

Tape	Embossed carrier tape (with dry pack)
Quantity	2500pcs
Direction of feed	E2 (The direction is the 1pin of product is at the upper left when you hold reel on the left hand and you pull out the tape on the right hand)

Reel 1pin Direction of feed

*Order quantity needs to be multiple of the minimum quantity.

Revision History

Date	Revision	Changes
09.Dec.2015	001	New Release

**Not Recommended for
New Designs**

Notice

Precaution on using ROHM Products

- Our Products are designed and manufactured for application in ordinary electronic equipments (such as AV equipment, OA equipment, telecommunication equipment, home electronic appliances, amusement equipment, etc.). If you intend to use our Products in devices requiring extremely high reliability (such as medical equipment ^(Note 1), transport equipment, traffic equipment, aircraft/spacecraft, nuclear power controllers, fuel controllers, car equipment including car accessories, safety devices, etc.) and whose malfunction or failure may cause loss of human life, bodily injury or serious damage to property ("Specific Applications"), please consult with the ROHM sales representative in advance. Unless otherwise agreed in writing by ROHM in advance, ROHM shall not be in any way responsible or liable for any damages, expenses or losses incurred by you or third parties arising from the use of any ROHM's Products for Specific Applications.

(Note1) Medical Equipment Classification of the Specific Applications

JAPAN	USA	EU	CHINA
CLASS III	CLASS III	CLASS II b	CLASS III
CLASS IV		CLASS III	

- ROHM designs and manufactures its Products subject to strict quality control system. However, semiconductor products can fail or malfunction at a certain rate. Please be sure to implement, at your own responsibilities, adequate safety measures including but not limited to fail-safe design against the physical injury, damage to any property, which a failure or malfunction of our Products may cause. The following are examples of safety measures:
 - Installation of protection circuits or other protective devices to improve system safety
 - Installation of redundant circuits to reduce the impact of single or multiple circuit failure
- Our Products are designed and manufactured for use under standard conditions and not under any special or extraordinary environments or conditions, as exemplified below. Accordingly, ROHM shall not be in any way responsible or liable for any damages, expenses or losses arising from the use of any ROHM's Products under any special or extraordinary environments or conditions. If you intend to use our Products under any special or extraordinary environments or conditions (as exemplified below), your independent verification and confirmation of product performance, reliability, etc. prior to use, must be necessary:
 - Use of our Products in any types of liquid, including water, oils, chemicals, and organic solvents
 - Use of our Products outdoors or in places where the Products are exposed to direct sunlight or dust
 - Use of our Products in places where the Products are exposed to sea wind or corrosive gases, including Cl₂, H₂S, NH₃, SO₂, and NO₂
 - Use of our Products in places where the Products are exposed to static electricity or electromagnetic waves
 - Use of our Products in proximity to heat-producing components, plastic cords, or other flammable items
 - Sealing or coating our Products with resin or other coating materials
 - Use of our Products without cleaning residue of flux (even if you use no-clean type fluxes, cleaning residue of flux is recommended); or Washing our Products by using water or water-soluble cleaning agents for cleaning residue after soldering
 - Use of the Products in places subject to dew condensation
- The Products are not subject to radiation-proof design.
- Please verify and confirm characteristics of the final or mounted products in using the Products.
- In particular, if a transient load (a large amount of load applied in a short period of time, such as pulse. is applied, confirmation of performance characteristics after on-board mounting is strongly recommended. Avoid applying power exceeding normal rated power; exceeding the power rating under steady-state loading condition may negatively affect product performance and reliability.
- De-rate Power Dissipation depending on ambient temperature. When used in sealed area, confirm that it is the use in the range that does not exceed the maximum junction temperature.
- Confirm that operation temperature is within the specified range described in the product specification.
- ROHM shall not be in any way responsible or liable for failure induced under deviant condition from what is defined in this document.

Precaution for Mounting / Circuit board design

- When a highly active halogenous (chlorine, bromine, etc.) flux is used, the residue of flux may negatively affect product performance and reliability.
- In principle, the reflow soldering method must be used on a surface-mount products, the flow soldering method must be used on a through hole mount products. If the flow soldering method is preferred on a surface-mount products, please consult with the ROHM representative in advance.

For details, please refer to ROHM Mounting specification

Precautions Regarding Application Examples and External Circuits

1. If change is made to the constant of an external circuit, please allow a sufficient margin considering variations of the characteristics of the Products and external components, including transient characteristics, as well as static characteristics.
2. You agree that application notes, reference designs, and associated data and information contained in this document are presented only as guidance for Products use. Therefore, in case you use such information, you are solely responsible for it and you must exercise your own independent verification and judgment in the use of such information contained in this document. ROHM shall not be in any way responsible or liable for any damages, expenses or losses incurred by you or third parties arising from the use of such information.

Precaution for Electrostatic

This Product is electrostatic sensitive product, which may be damaged due to electrostatic discharge. Please take proper caution in your manufacturing process and storage so that voltage exceeding the Products maximum rating will not be applied to Products. Please take special care under dry condition (e.g. Grounding of human body / equipment / solder iron, isolation from charged objects, setting of ionizer, friction prevention and temperature / humidity control).

Precaution for Storage / Transportation

1. Product performance and soldered connections may deteriorate if the Products are stored in the places where:
 - [a] the Products are exposed to sea winds or corrosive gases, including Cl₂, H₂S, NH₃, SO₂, and NO₂
 - [b] the temperature or humidity exceeds those recommended by ROHM
 - [c] the Products are exposed to direct sunshine or condensation
 - [d] the Products are exposed to high Electrostatic
2. Even under ROHM recommended storage condition, solderability of products out of recommended storage time period may be degraded. It is strongly recommended to confirm solderability before using Products of which storage time is exceeding the recommended storage time period.
3. Store / transport cartons in the correct direction, which is indicated on a carton with a symbol. Otherwise bent leads may occur due to excessive stress applied when dropping of a carton.
4. Use Products within the specified time after opening a humidity barrier bag. Baking is required before using Products of which storage time is exceeding the recommended storage time period.

Precaution for Product Label

QR code printed on ROHM Products label is for ROHM's internal use only.

Precaution for Disposition

When disposing Products please dispose them properly using an authorized industry waste company.

Precaution for Foreign Exchange and Foreign Trade act

Since concerned goods might be fallen under listed items of export control prescribed by Foreign exchange and Foreign trade act, please consult with ROHM in case of export.

Precaution Regarding Intellectual Property Rights

1. All information and data including but not limited to application example contained in this document is for reference only. ROHM does not warrant that foregoing information or data will not infringe any intellectual property rights or any other rights of any third party regarding such information or data.
2. ROHM shall not have any obligations where the claims, actions or demands arising from the combination of the Products with other articles such as components, circuits, systems or external equipment (including software).
3. No license, expressly or implied, is granted hereby under any intellectual property rights or other rights of ROHM or any third parties with respect to the Products or the information contained in this document. Provided, however, that ROHM will not assert its intellectual property rights or other rights against you or your customers to the extent necessary to manufacture or sell products containing the Products, subject to the terms and conditions herein.

Other Precaution

1. This document may not be reprinted or reproduced, in whole or in part, without prior written consent of ROHM.
2. The Products may not be disassembled, converted, modified, reproduced or otherwise changed without prior written consent of ROHM.
3. In no event shall you use in any way whatsoever the Products and the related technical information contained in the Products or this document for any military purposes, including but not limited to, the development of mass-destruction weapons.
4. The proper names of companies or products described in this document are trademarks or registered trademarks of ROHM, its affiliated companies or third parties.

General Precaution

1. Before you use our Products, you are requested to carefully read this document and fully understand its contents. ROHM shall not be in any way responsible or liable for failure, malfunction or accident arising from the use of any ROHM's Products against warning, caution or note contained in this document.
2. All information contained in this document is current as of the issuing date and subject to change without any prior notice. Before purchasing or using ROHM's Products, please confirm the latest information with a ROHM sales representative.
3. The information contained in this document is provided on an "as is" basis and ROHM does not warrant that all information contained in this document is accurate and/or error-free. ROHM shall not be in any way responsible or liable for any damages, expenses or losses incurred by you or third parties resulting from inaccuracy or errors of or concerning such information.

**Not Recommended for
New Designs**





BD6889GU - Web Page

Part Number	BD6889GU
Package	VBGA063T050
Unit Quantity	2500
Minimum Package Quantity	2500
Packing Type	Taping
Constitution Materials List	inquiry
RoHS	Yes

Looking for pricing, stock, or lifecycle information?

Click below to explore more details on WIN SOURCE:

-  [View BD6889GU-E2 on WIN SOURCE](#)
-  [Rohm Semiconductor](#) Information

Optimize Your Supply Chain with WIN SOURCE Solutions

-  Global Sourcing Solution
-  Obsolete Management
-  Cost Control Management
-  Shortage Management
-  Alternative Solution
-  Excess Inventory Management