



**THE DATASHEET OF
IRGS4620DPBF**



Insulated Gate Bipolar Transistor with Ultrafast Soft Recovery Diode

$V_{CES} = 600V$
 $I_C = 20A, T_C = 100^\circ C$
 $t_{SC} \geq 5\mu s, T_{J(max)} = 175^\circ C$
 $V_{CE(ON)}$ typ. = 1.55V @ $I_C = 12A$

Applications

- Industrial Motor Drive
- Inverters
- UPS
- Welding

G	C	E
Gate	Collector	Emitter

Features	Benefits
Low $V_{CE(ON)}$ and switching losses	High efficiency in a wide range of applications and switching frequencies
Square RBSOA and maximum junction temperature 175°C	Improved reliability due to rugged hard switching performance and high power capability
Positive $V_{CE(ON)}$ temperature coefficient	Excellent current sharing in parallel operation
5µs Short Circuit SOA	Enables short circuit protection scheme
Lead-Free, RoHS Compliant	Environmentally friendly

Base part number	Package Type	Standard Pack		Orderable Part Number
		Form	Quantity	
IRGB4620DPbF	TO-220AB	Tube	50	IRGB4620DPbF
IRGIB4620DPbF	TO-220AB Full-Pak	Tube	50	IRGIB4620DPbF
IRGP4620DPbF	TO-247AC	Tube	25	IRGP4620DPbF
IRGP4620D-EPbF	TO-247AD	Tube	25	IRGP4620D-EPbF
IRGS4620DPbF	D²Pak	Tube	50	IRGS4620DPbF
		Tape and Reel Right	800	IRGS4620DTRRPbF
		Tape and Reel Left	800	IRGS4620DTRLpbF

Absolute Maximum Ratings

	Parameter	Max.	Units	
V_{CES}	Collector-to-Emitter Voltage	600	V	
$I_C @ T_C = 25^\circ\text{C}$	Continuous Collector Current ^①	32	A	
$I_C @ T_C = 100^\circ\text{C}$	Continuous Collector Current ^①	20		
I_{CM}	Pulse Collector Current, $V_{GE} = 15\text{V}$ ^④	36		
I_{LM}	Clamped Inductive Load Current, $V_{GE} = 20\text{V}$ ^⑦	48		
$I_F @ T_C = 25^\circ\text{C}$	Diode Continuous Forward Current ^①	16		
$I_F @ T_C = 100^\circ\text{C}$	Diode Continuous Forward Current ^①	10		
I_{FM}	Diode Maximum Forward Current ^④	48		
V_{GE}	Continuous Gate-to-Emitter Voltage	± 20	V	
	Transient Gate to Emitter Voltage	± 30		
$P_D @ T_C = 25^\circ\text{C}$	Maximum Power Dissipation	140	W	
$P_D @ T_C = 100^\circ\text{C}$	Maximum Power Dissipation	70		
T_J	Operating Junction and	-40 to +175	C	
T_{STG}	Storage Temperature Range			
	Soldering Temperature, for 10 sec. (1.6mm from case)			300
	Mounting Torque, 6-32 or M3 Screw (TO-220, TO-247)			10 lbf·in (1.1 N·m)

Thermal Resistance

	Parameter	Min.	Typ.	Max.	Units
$R_{\theta JC}$ (IGBT) ^②	Thermal Resistance Junction-to-Case (D ² Pak, TO-220)	—	—	1.07	°C/W
	Thermal Resistance Junction-to-Case (TO-220 Full-Pak)	—	—	3.75	
	Thermal Resistance Junction-to-Case (TO-247)	—	—	1.12	
$R_{\theta JC}$ (Diode) ^②	Thermal Resistance Junction-to-Case (D ² Pak, TO-220)	—	—	3.66	
	Thermal Resistance Junction-to-Case (TO-220 Full-Pak)	—	—	6.22	
	Thermal Resistance Junction-to-Case (TO-247)	—	—	3.71	
$R_{\theta CS}$	Thermal Resistance, Case-to-Sink (flat, greased surface-TO-220, D ² Pak, TO-220 Full-Pak)	—	0.50	—	
	Thermal Resistance Case-to-Sink (TO-247)	—	0.24	—	
$R_{\theta JA}$	Thermal Resistance, Junction-to-Ambient (PCB Mount - D ² Pak) ^⑥	—	—	40	
	Thermal Resistance, Junction-to-Ambient (Socket Mount –TO-247)	—	—	40	
	Thermal Resistance, Junction-to-Ambient (Socket Mount –TO-220)	—	—	62	
	Thermal Resistance, Junction-to-Ambient (Socket Mount –TO-220 Full-Pak)	—	—	65	

Electrical Characteristics @ $T_J = 25^\circ\text{C}$ (unless otherwise specified)

	Parameter	Min.	Typ.	Max.	Units	Conditions
$V_{(BR)CES}$	Collector-to-Emitter Breakdown Voltage	600	—	—	V	$V_{GE} = 0\text{V}$, $I_C = 100\mu\text{A}$ ^③
$\Delta V_{(BR)CES}/\Delta T_J$	Temperature Coeff. of Breakdown Voltage	—	0.40	—	V/°C	$V_{GE} = 0\text{V}$, $I_C = 1\text{mA}$ (25°C-175°C)
$V_{CE(on)}$	Collector-to-Emitter Saturation Voltage	—	1.55	1.85	V	$I_C = 12\text{A}$, $V_{GE} = 15\text{V}$, $T_J = 25^\circ\text{C}$
		—	1.90	—		$I_C = 12\text{A}$, $V_{GE} = 15\text{V}$, $T_J = 150^\circ\text{C}$
		—	1.97	—		$I_C = 12\text{A}$, $V_{GE} = 15\text{V}$, $T_J = 175^\circ\text{C}$
$V_{GE(th)}$	Gate Threshold Voltage	4.0	—	6.5	V	$V_{CE} = V_{GE}$, $I_C = 350\mu\text{A}$
$\Delta V_{GE(th)}/\Delta T_J$	Threshold Voltage Temp. Coefficient	—	-18	—	mV/°C	$V_{CE} = V_{GE}$, $I_C = 1.0\text{mA}$ (25°C-175°C)
g_{fe}	Forward Transconductance	—	7.7	—	S	$V_{CE} = 50\text{V}$, $I_C = 12\text{A}$, $PW = 80\mu\text{s}$
I_{CES}	Collector-to-Emitter Leakage Current	—	2.0	—	μA	$V_{GE} = 0\text{V}$, $V_{CE} = 600\text{V}$
		—	475	—		$V_{GE} = 0\text{V}$, $V_{CE} = 600\text{V}$, $T_J = 175^\circ\text{C}$
I_{GES}	Gate-to-Emitter Leakage Current	—	—	± 100	nA	$V_{GE} = \pm 20\text{V}$
V_{FM}	Diode Forward Voltage Drop	—	2.1	3.1	V	$I_F = 12\text{A}$
		—	1.6	—		$I_F = 12\text{A}$, $T_J = 175^\circ\text{C}$

Switching Characteristics @ $T_J = 25^\circ\text{C}$ (unless otherwise specified)

	Parameter	Min.	Typ.	Max	Units	Conditions
Q_g	Total Gate Charge	—	25	—	nC	$I_C = 12\text{A}$ $V_{GE} = 15\text{V}$ $V_{CC} = 400\text{V}$
Q_{ge}	Gate-to-Emitter Charge	—	7.0	—		
Q_{gc}	Gate-to-Collector Charge	—	11	—		
E_{on}	Turn-On Switching Loss	—	75	—	μJ	$I_C = 12\text{A}$, $V_{CC} = 400\text{V}$, $V_{GE} = 15\text{V}$ $R_G = 22\Omega$, $L = 200\mu\text{H}$, $L_S = 150\text{nH}$, $T_J = 25^\circ\text{C}$
E_{off}	Turn-Off Switching Loss	—	225	—		
E_{total}	Total Switching Loss	—	300	—		
$t_{d(on)}$	Turn-On delay time	—	31	—	ns	Energy losses include tail & diode reverse recovery ⑤
t_r	Rise time	—	17	—		
$t_{d(off)}$	Turn-Off delay time	—	83	—		
t_f	Fall time	—	24	—		
E_{on}	Turn-On Switching Loss	—	185	—	μJ	$I_C = 12\text{A}$, $V_{CC} = 400\text{V}$, $V_{GE} = 15\text{V}$ $R_G = 22\Omega$, $L = 200\mu\text{H}$, $L_S = 150\text{nH}$, $T_J = 175^\circ\text{C}$
E_{off}	Turn-Off Switching Loss	—	355	—		
E_{total}	Total Switching Loss	—	540	—		
$t_{d(on)}$	Turn-On delay time	—	30	—	ns	Energy losses include tail & diode reverse recovery ⑤
t_r	Rise time	—	18	—		
$t_{d(off)}$	Turn-Off delay time	—	102	—		
t_f	Fall time	—	41	—		
C_{ies}	Input Capacitance	—	765	—	pF	$V_{GE} = 0\text{V}$ $V_{CC} = 30\text{V}$ $f = 1.0\text{MHz}$
C_{oes}	Output Capacitance	—	52	—		
C_{res}	Reverse Transfer Capacitance	—	23	—		
RBSOA	Reverse Bias Safe Operating Area	FULL SQUARE				$T_J = 175^\circ\text{C}$, $I_C = 48\text{A}$ $V_{CC} = 480\text{V}$, $V_p \leq 600\text{V}$ $R_G = 22\Omega$, $V_{GE} = +20\text{V}$ to 0V
SCSOA	Short Circuit Safe Operating Area	5.0	—	—	μs	$V_{CC} = 400\text{V}$, $V_p \leq 600\text{V}$ $R_G = 22\Omega$, $V_{GE} = +15\text{V}$ to 0V
E_{rec}	Reverse Recovery Energy of the Diode	—	280	—	μJ	$T_J = 175^\circ\text{C}$
t_{rr}	Diode Reverse Recovery Time	—	68	—	ns	$V_{CC} = 400\text{V}$, $I_F = 12\text{A}$, $V_{GE} = 15\text{V}$, $R_G = 22\Omega$, $L = 200\mu\text{H}$, $L_S = 150\text{nH}$
I_{rr}	Peak Reverse Recovery Current	—	19	—	A	

Notes:

- ① Limited by maximum junction temperature. Not applicable for Full-Pak package: current value limited by $R_{\theta JC}$.
- ② R_{θ} is measured at T_J of approximately 90°C .
- ③ Refer to AN-1086 for guidelines for measuring $V_{(BR)CES}$ safely.
- ④ Pulse width limited by maximum junction temperature.
- ⑤ Values influenced by parasitic L and C in measurement.
- ⑥ When mounted on 1" square PCB (FR-4 or G-10 Material). For recommended footprint and soldering techniques refer to application note #AN-994. <http://www.irf.com/technical-info/appnotes/an-994.pdf>
- ⑦ $V_{CC} = 80\%$ (V_{CES}), $V_{GE} = 20\text{V}$, $L = 100\mu\text{H}$, $R_G = 22\Omega$.

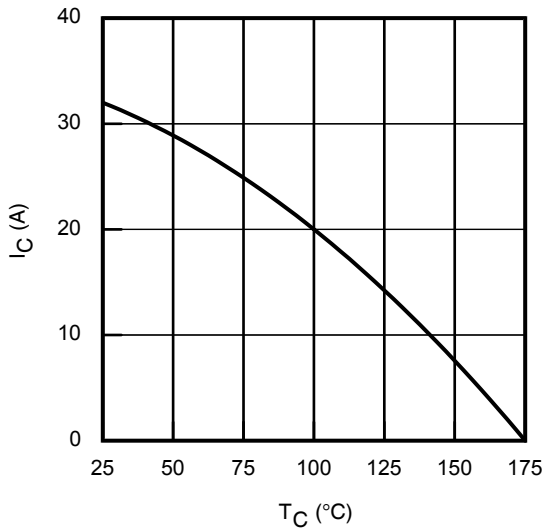

Fig. 1 - Maximum DC Collector Current vs. Case Temperature

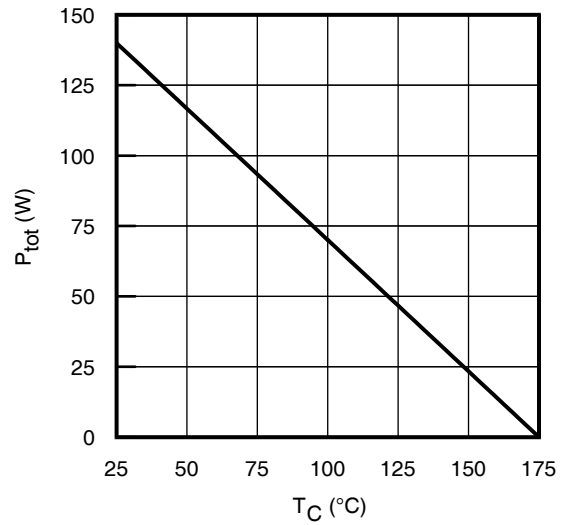

Fig. 2 - Power Dissipation vs. Case Temperature

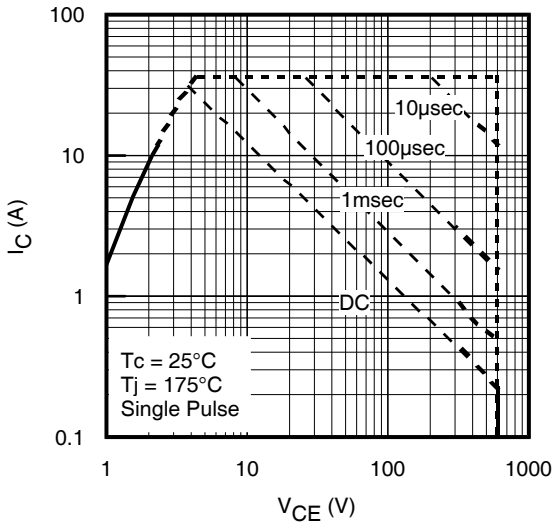

Fig. 3 - Forward SOA

$T_C = 25^\circ\text{C}$; $T_J \leq 175^\circ\text{C}$; $V_{GE} = 15\text{V}$

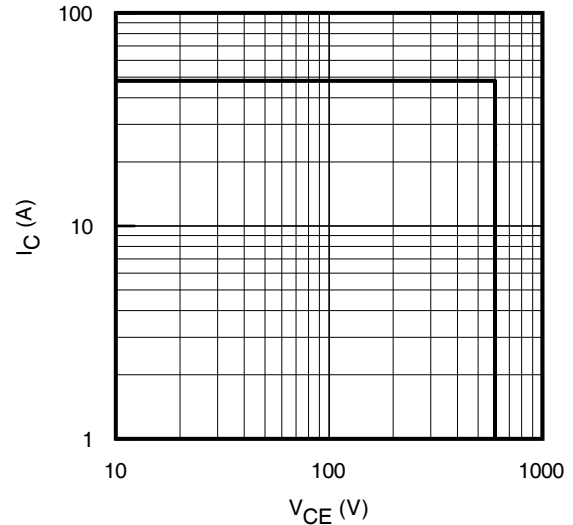

Fig. 4 - Reverse Bias SOA

$T_J = 175^\circ\text{C}$; $V_{GE} = 20\text{V}$

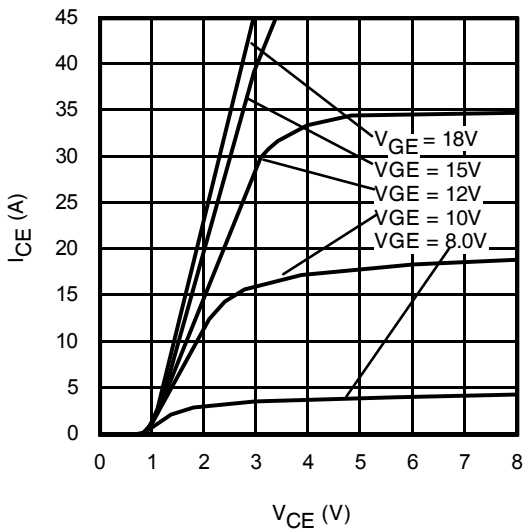

Fig. 5 - Typ. IGBT Output Characteristics
 $T_J = -40^\circ\text{C}$; $t_p = 80\mu\text{s}$

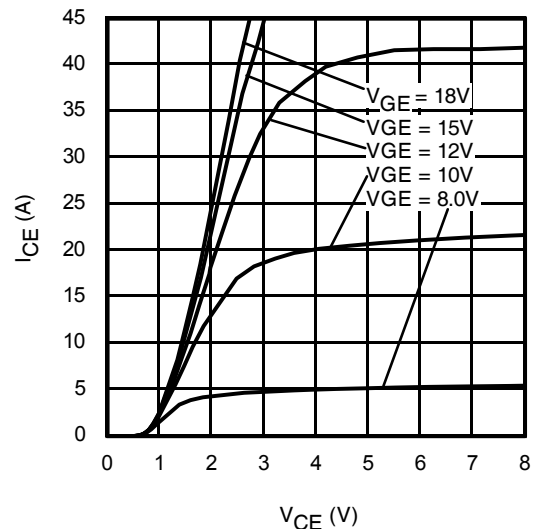

Fig. 6 - Typ. IGBT Output Characteristics
 $T_J = 25^\circ\text{C}$; $t_p = 80\mu\text{s}$

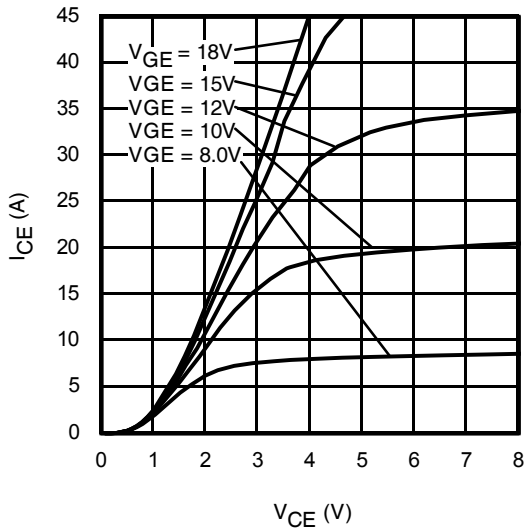

Fig. 7 - Typ. IGBT Output Characteristics
 $T_J = 175^\circ\text{C}$; $t_p = 80\mu\text{s}$

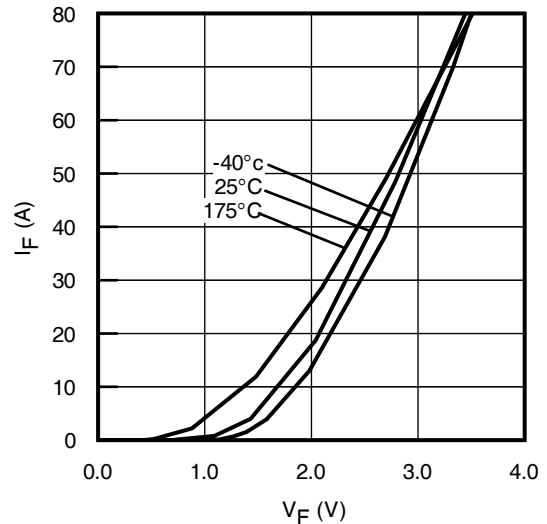

Fig. 8 - Typ. Diode Forward Voltage Drop Characteristics

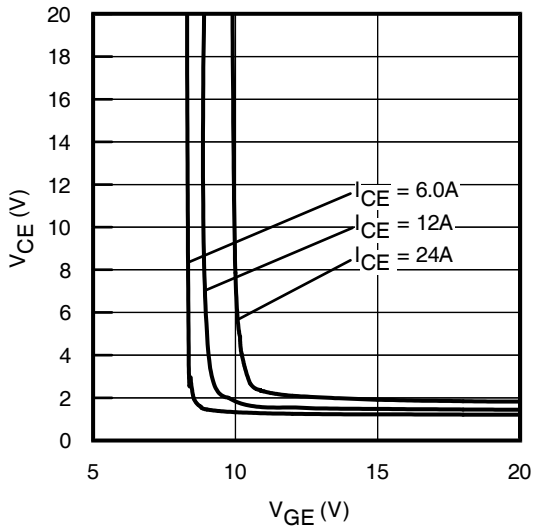

Fig. 9 - Typical V_{CE} vs. V_{GE}
 $T_J = -40^\circ\text{C}$

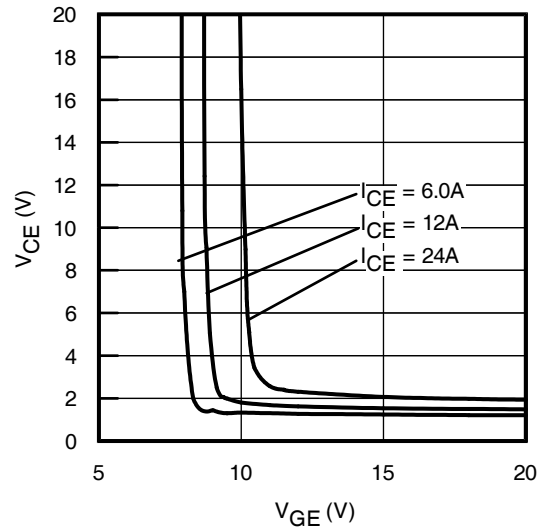

Fig. 10 - Typical V_{CE} vs. V_{GE}
 $T_J = 25^\circ\text{C}$

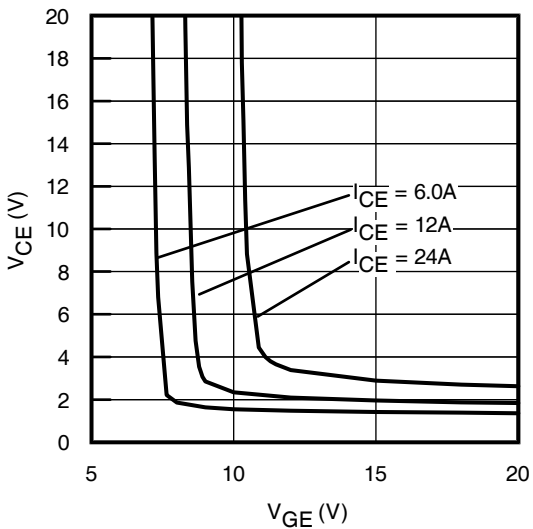

Fig. 11 - Typical V_{CE} vs. V_{GE}
 $T_J = 175^\circ\text{C}$

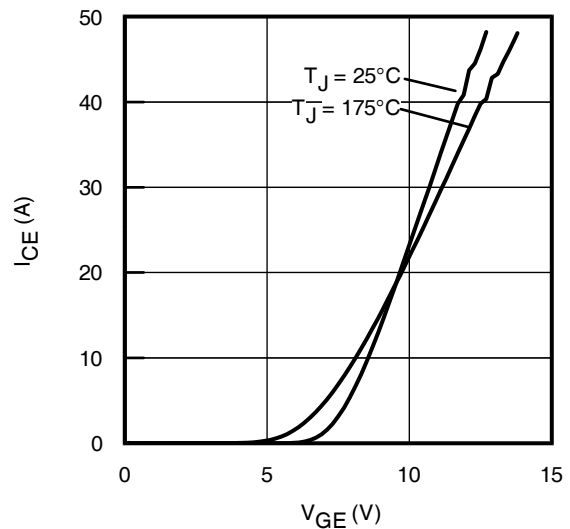
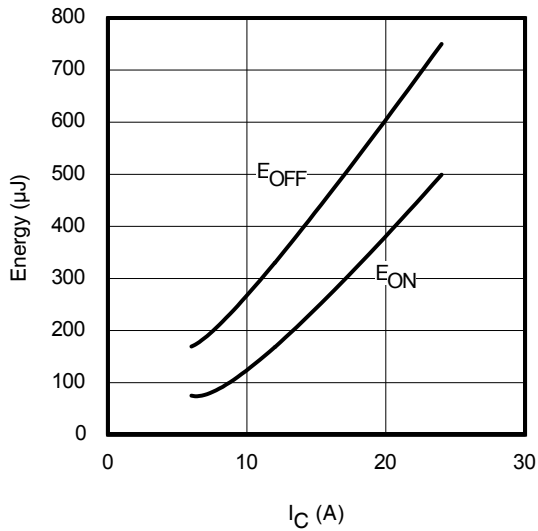
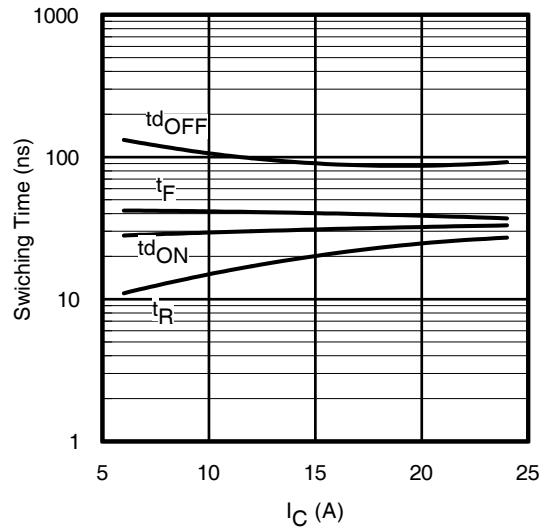
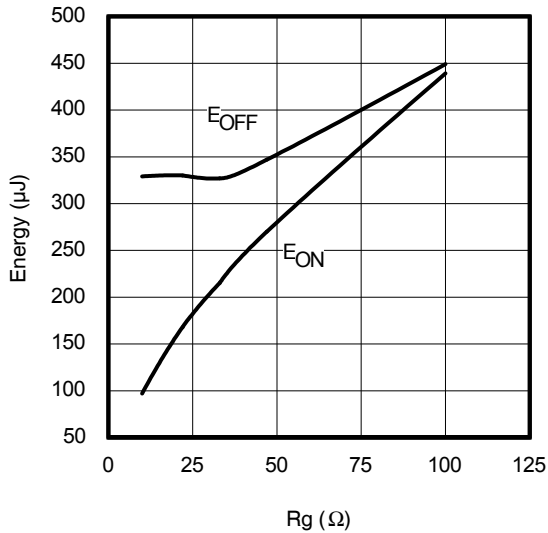
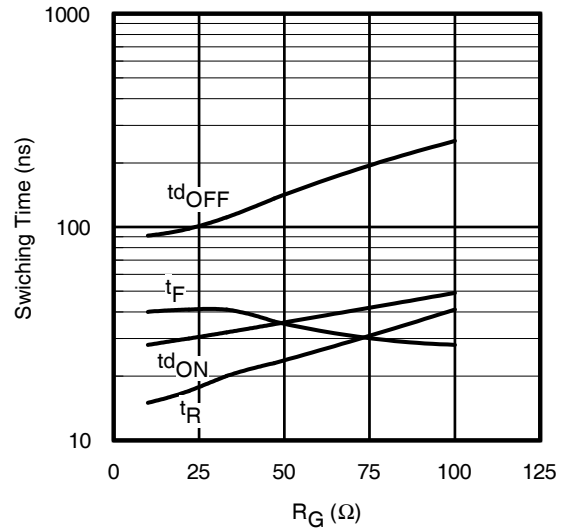
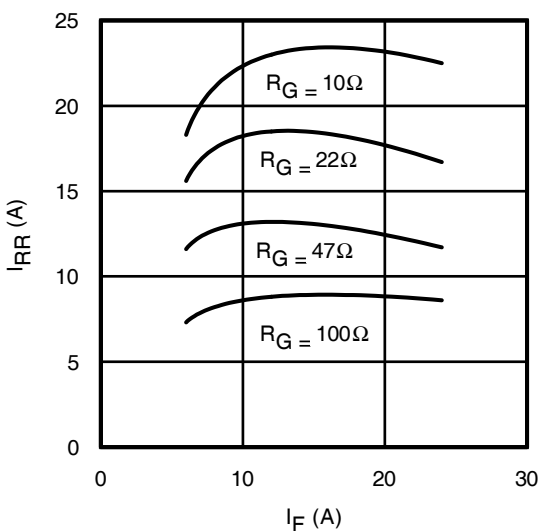
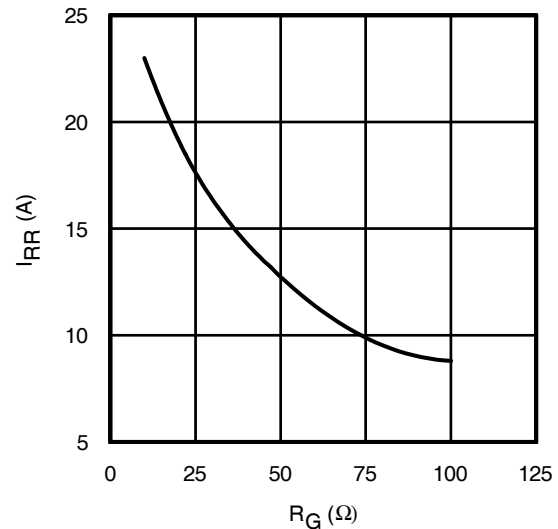

Fig. 12 - Typ. Transfer Characteristics
 $V_{CE} = 50\text{V}$; $t_p = 10\mu\text{s}$

Fig. 13 - Typ. Energy Loss vs. I_C
 $T_J = 175^\circ\text{C}; L = 200\mu\text{H}; V_{CE} = 400\text{V}; R_G = 22\Omega; V_{GE} = 15\text{V}$

Fig. 14 - Typ. Switching Time vs. I_C
 $T_J = 175^\circ\text{C}; L = 200\mu\text{H}; V_{CE} = 400\text{V}; R_G = 22\Omega; V_{GE} = 15\text{V}$

Fig. 15 - Typ. Energy Loss vs. R_G
 $T_J = 175^\circ\text{C}; L = 200\mu\text{H}; V_{CE} = 400\text{V}; I_{CE} = 12\text{A}; V_{GE} = 15\text{V}$

Fig. 16 - Typ. Switching Time vs. R_G
 $T_J = 175^\circ\text{C}; L = 200\mu\text{H}; V_{CE} = 400\text{V}; I_{CE} = 12\text{A}; V_{GE} = 15\text{V}$

Fig. 17 - Typ. Diode I_{RR} vs. I_F
 $T_J = 175^\circ\text{C}$

Fig. 18 - Typ. Diode I_{RR} vs. R_G
 $T_J = 175^\circ\text{C}$

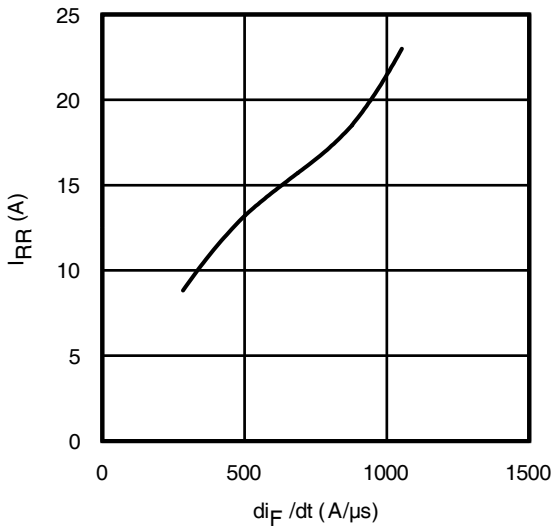

Fig. 19 - Typ. Diode I_{RR} vs. di_F/dt
 $V_{CC} = 400V$; $V_{GE} = 15V$; $I_F = 12A$; $T_J = 175^\circ C$

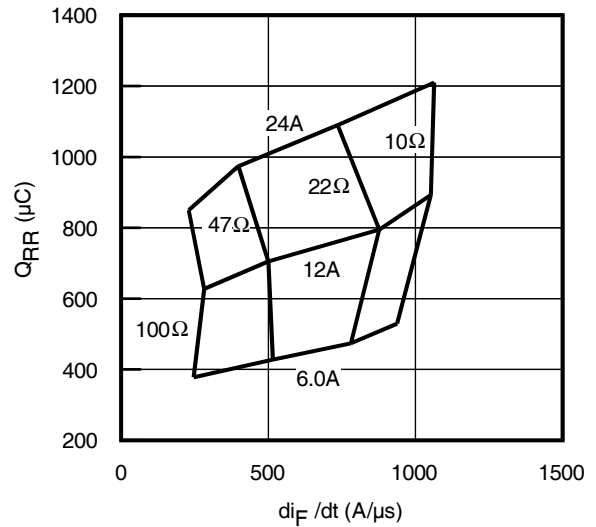

Fig. 20 - Typ. Diode Q_{RR} vs. di_F/dt
 $V_{CC} = 400V$; $V_{GE} = 15V$; $T_J = 175^\circ C$

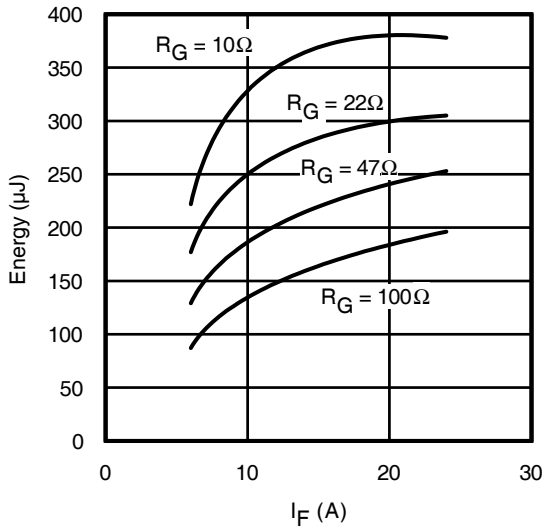

Fig. 21 - Typ. Diode E_{RR} vs. I_F
 $T_J = 175^\circ C$

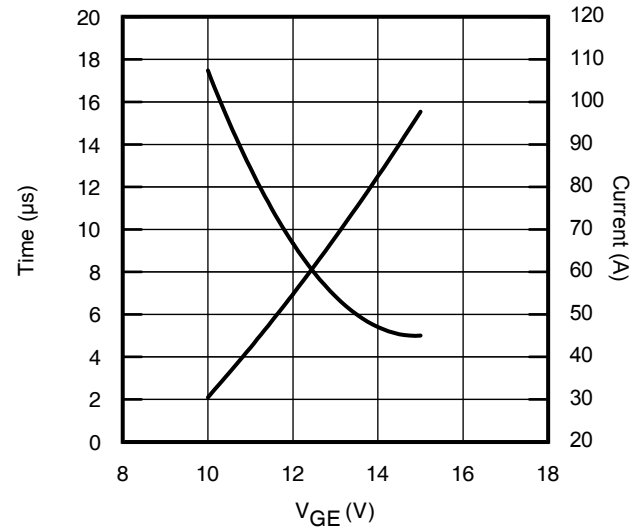

Fig. 22 - V_{GE} vs. Short Circuit Time
 $V_{CC} = 400V$; $T_C = 25^\circ C$

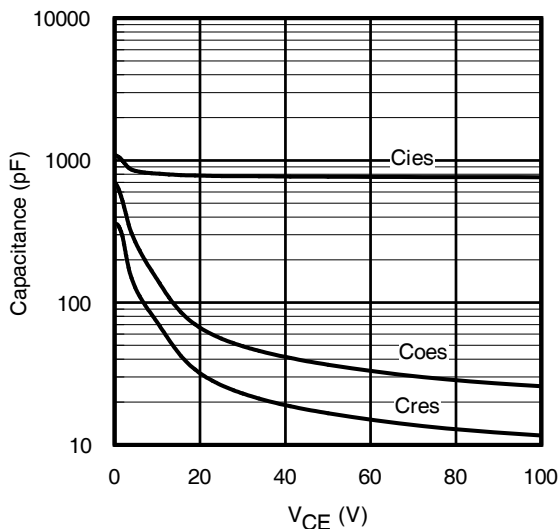

Fig. 23 - Typ. Capacitance vs. V_{CE}
 $V_{GE} = 0V$; $f = 1MHz$

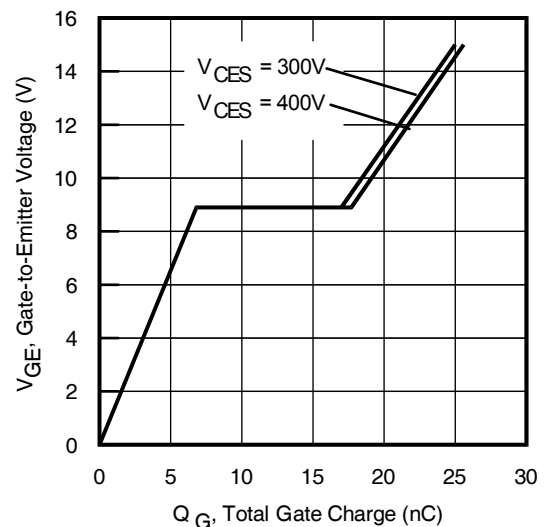
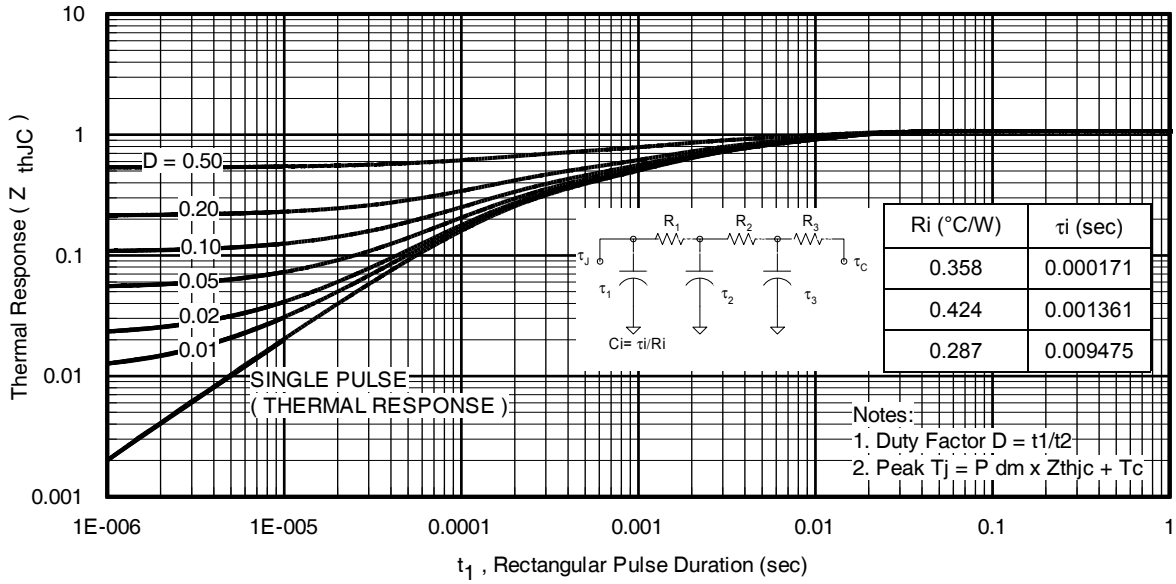
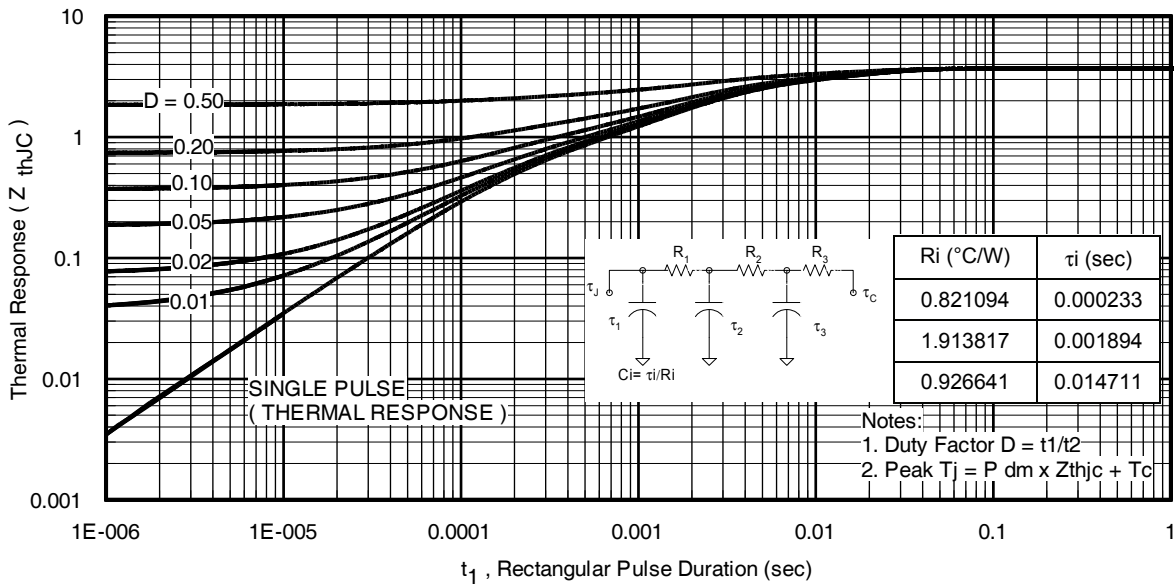
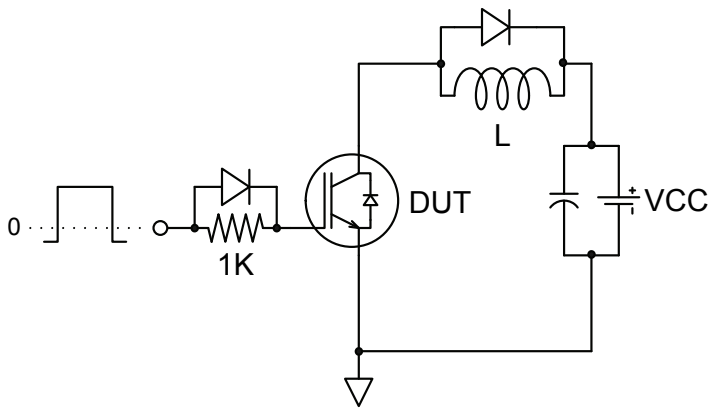
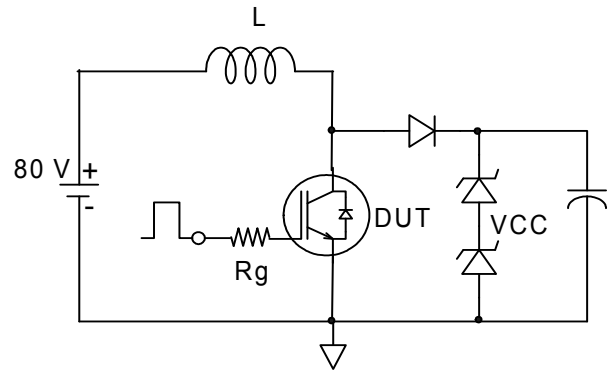
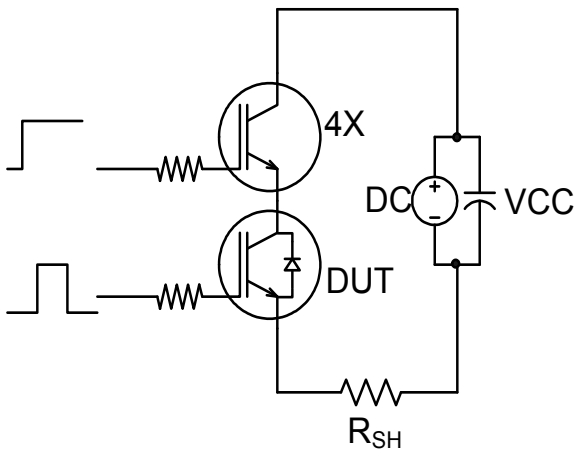
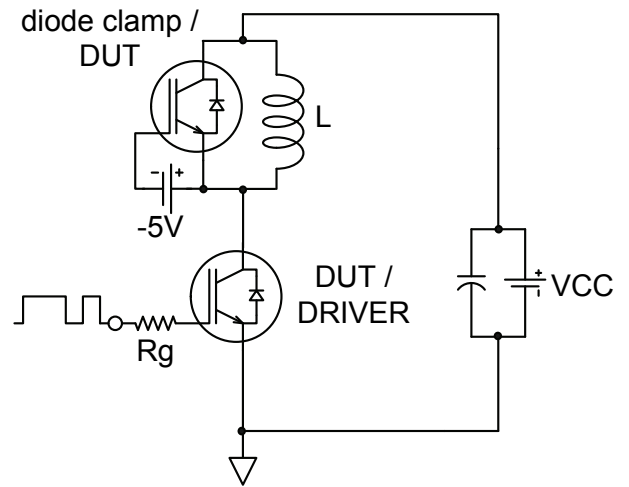
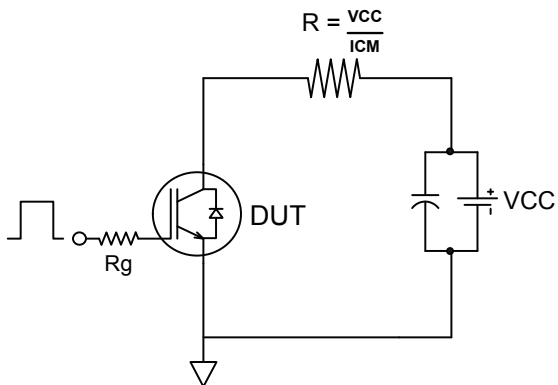
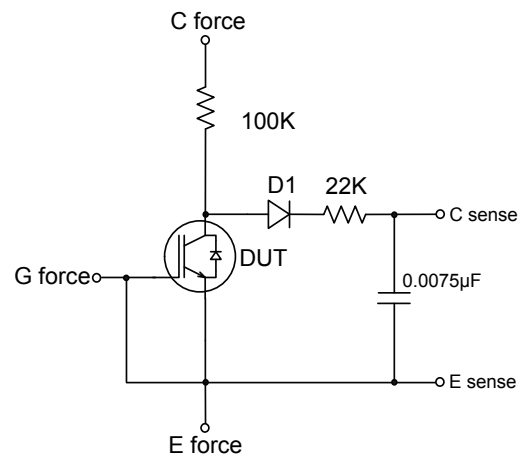

Fig. 24 - Typical Gate Charge vs. V_{GE}
 $I_{CE} = 12A$; $L = 600\mu H$

Fig. 25 - Maximum Transient Thermal Impedance, Junction-to-Case (IGBT-TO-220Pak)

Fig. 26 - Maximum Transient Thermal Impedance, Junction-to-Case (DIODE-TO-220Pak)

Fig.C.T.1 - Gate Charge Circuit (turn-off)

Fig.C.T.2 - RBSOA Circuit

Fig.C.T.3 - S.C. SOA Circuit

Fig.C.T.4 - Switching Loss Circuit

Fig.C.T.5 - Resistive Load Circuit

Fig.C.T.6 - BVCES Filter Circuit

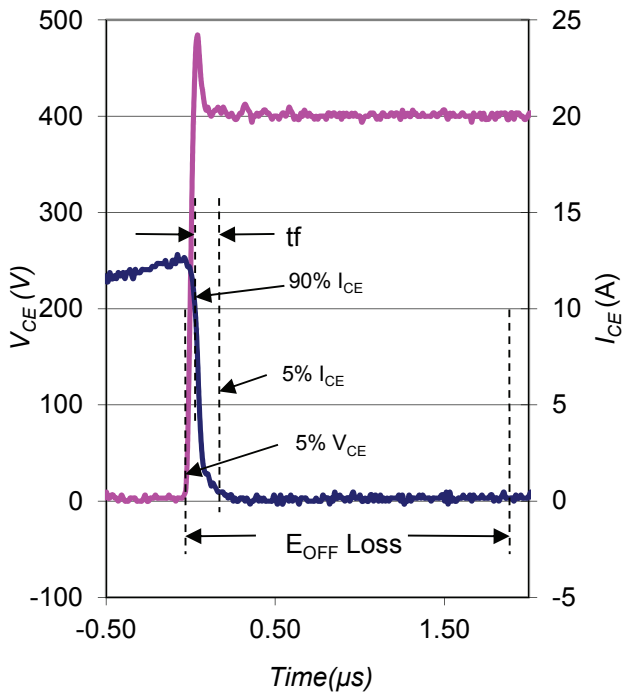

Fig. WF1 - Typ. Turn-off Loss Waveform
@ $T_J = 175^\circ\text{C}$ using Fig. CT.4

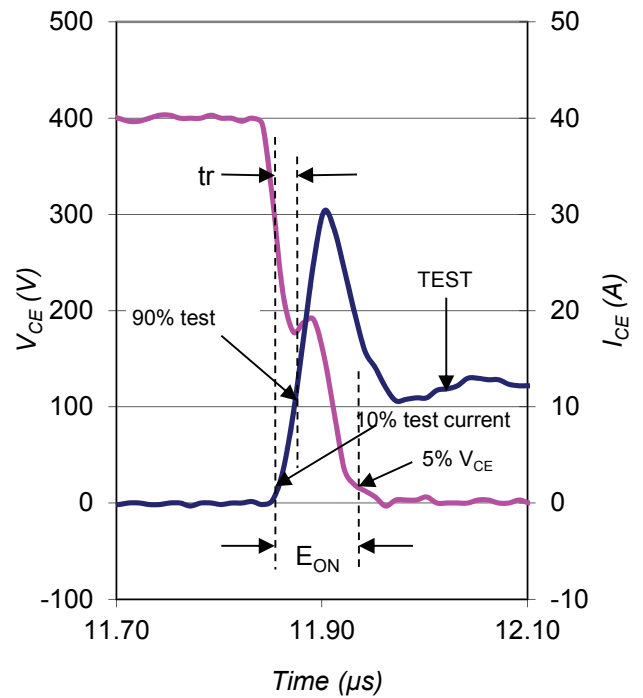

Fig. WF2 - Typ. Turn-on Loss Waveform
@ $T_J = 175^\circ\text{C}$ using Fig. CT.4

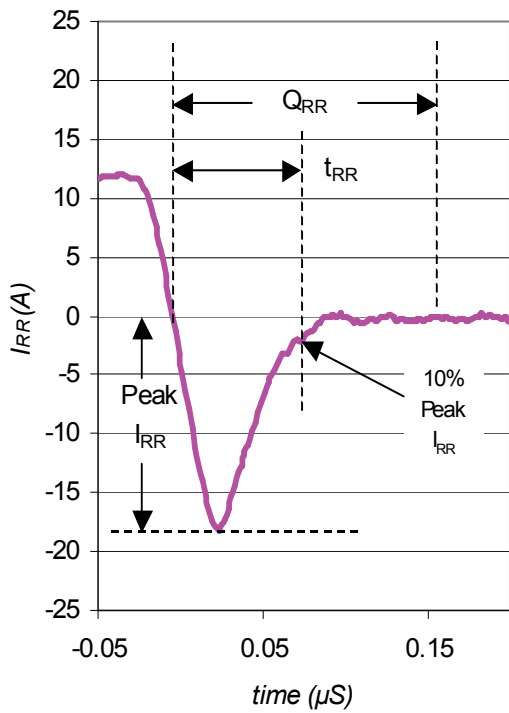

Fig. WF3 - Typ. Diode Recovery Waveform
@ $T_J = 175^\circ\text{C}$ using Fig. CT.4

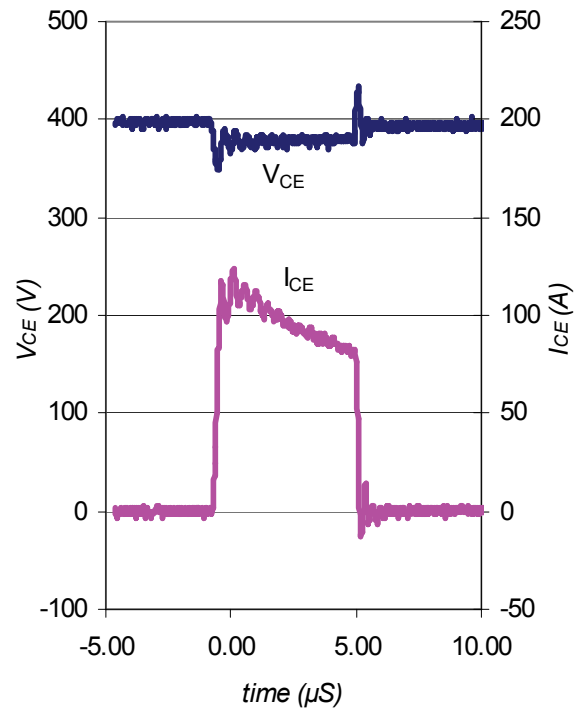
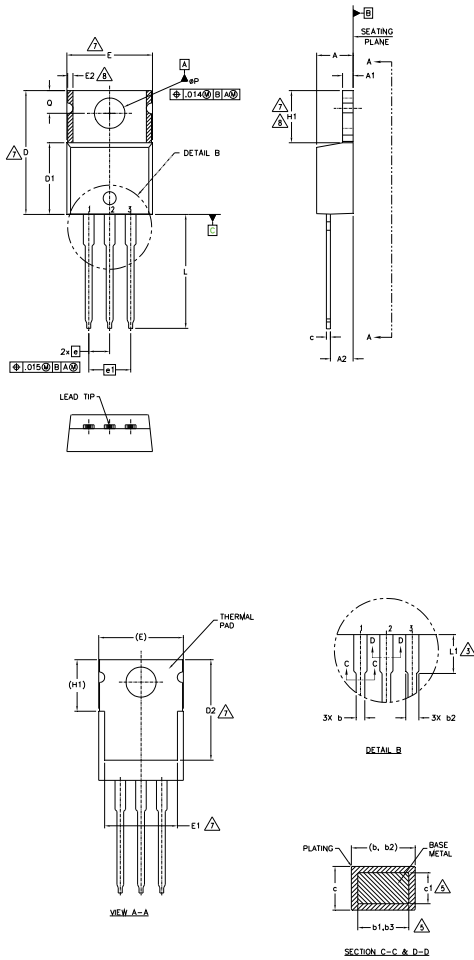

Fig. WF4 - Typ. S.C. Waveform
@ $T_J = 150^\circ\text{C}$ using Fig. CT.3

TO-220AB Package Outline

(Dimensions are shown in millimeters (inches))



NOTES:

- 1.- DIMENSIONING AND TOLERANCING AS PER ASME Y14.5 M- 1994.
- 2.- DIMENSIONS ARE SHOWN IN INCHES [MILLIMETERS].
- 3.- LEAD DIMENSION AND FINISH UNCONTROLLED IN L1.
- 4.- DIMENSION D, D1 & E DO NOT INCLUDE MOLD FLASH. MOLD FLASH SHALL NOT EXCEED .005" (0.127) PER SIDE. THESE DIMENSIONS ARE MEASURED AT THE OUTERMOST EXTREMES OF THE PLASTIC BODY.
- 5.- DIMENSION b1, b3 & c1 APPLY TO BASE METAL ONLY.
- 6.- CONTROLLING DIMENSION : INCHES.
- 7.- THERMAL PAD CONTOUR OPTIONAL WITHIN DIMENSIONS E,H1,D2 & E1
- 8.- DIMENSION E2 X H1 DEFINE A ZONE WHERE STAMPING AND SINGULATION IRREGULARITIES ARE ALLOWED.
- 9.- OUTLINE CONFORMS TO JEDEC TO-220, EXCEPT A2 (max.) AND D2 (min.) WHERE DIMENSIONS ARE DERIVED FROM THE ACTUAL PACKAGE OUTLINE.

SYMBOL	DIMENSIONS				NOTES
	MILLIMETERS		INCHES		
	MIN.	MAX.	MIN.	MAX.	
A	3.56	4.83	.140	.190	
A1	1.14	1.40	.045	.055	
A2	2.03	2.92	.080	.115	
b	0.38	1.01	.015	.040	
b1	0.38	0.97	.015	.038	5
b2	1.14	1.78	.045	.070	
b3	1.14	1.73	.045	.068	5
c	0.36	0.61	.014	.024	
c1	0.36	0.56	.014	.022	5
D	14.22	16.51	.560	.650	4
D1	8.38	9.02	.330	.355	
D2	11.68	12.88	.460	.507	7
E	9.65	10.67	.380	.420	4,7
E1	6.86	8.89	.270	.350	7
E2	-	0.76	-	.030	8
e	2.54 BSC		.100 BSC		
e1	5.08 BSC		.200 BSC		
H1	5.84	6.86	.230	.270	7,8
L	12.70	14.73	.500	.580	
L1	3.56	4.06	.140	.160	3
ØP	3.54	4.08	.139	.161	
Q	2.54	3.42	.100	.135	

LEAD ASSIGNMENTS

HEXFET

- 1.- GATE
- 2.- DRAIN
- 3.- SOURCE

IGBTs, CoPACK

- 1.- GATE
- 2.- COLLECTOR
- 3.- EMITTER

DIODES

- 1.- ANODE
- 2.- CATHODE
- 3.- ANODE

TO-220AB Part Marking Information

EXAMPLE: THIS IS AN IRF1010
 LOT CODE 1789
 ASSEMBLED ON WW 19, 2000
 IN THE ASSEMBLY LINE "C"

Note: "P" in assembly line position indicates "Lead - Free"

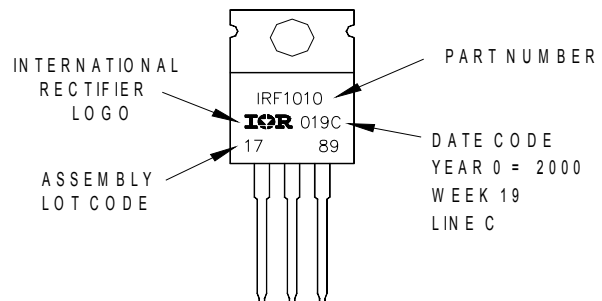

TO-220AB package is not recommended for Surface Mount Application.

TO-247AC Package Outline

Dimensions are shown in millimeters (inches)

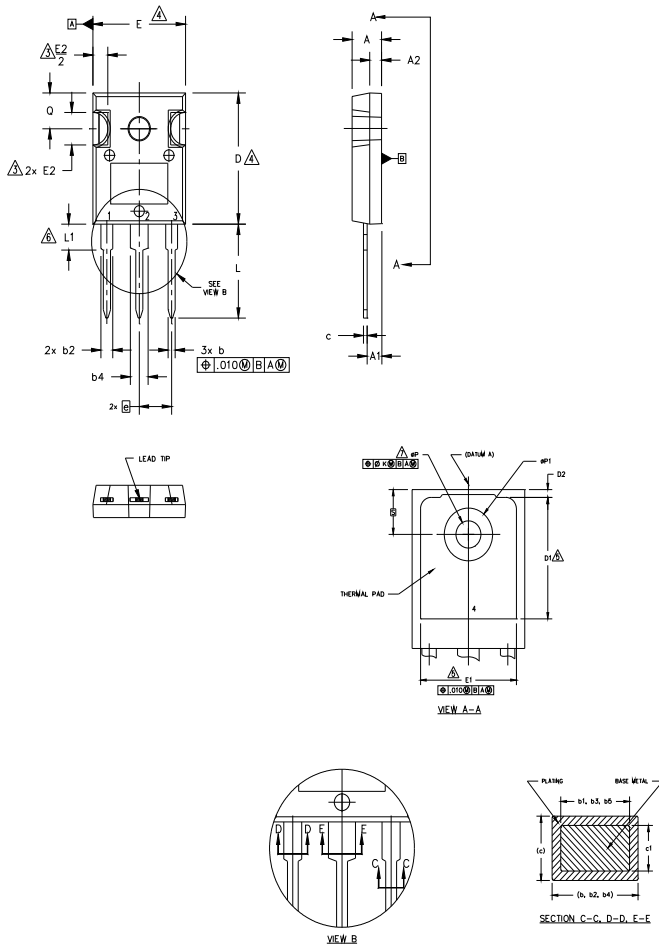

NOTES:

1. DIMENSIONING AND TOLERANCING AS PER ASME Y14.5M 1994.
2. DIMENSIONS ARE SHOWN IN INCHES.
3. CONTOUR OF SLOT OPTIONAL.
4. DIMENSION D & E DO NOT INCLUDE MOLD FLASH. MOLD FLASH SHALL NOT EXCEED .005" (0.127) PER SIDE. THESE DIMENSIONS ARE MEASURED AT THE OUTERMOST EXTREMES OF THE PLASTIC BODY.
5. THERMAL PAD CONTOUR OPTIONAL WITHIN DIMENSIONS D1 & E1.
6. LEAD FINISH UNCONTROLLED IN L1.
7. ØP TO HAVE A MAXIMUM DRAFT ANGLE OF 1.5 ° TO THE TOP OF THE PART WITH A MAXIMUM HOLE DIAMETER OF .154 INCH.
8. OUTLINE CONFORMS TO JEDEC OUTLINE TO-247AC .

SYMBOL	DIMENSIONS				NOTES
	INCHES		MILLIMETERS		
	MIN.	MAX.	MIN.	MAX.	
A	.183	.209	4.65	5.31	4 5 4 LEAD ASSIGNMENTS HEXFET 1.- GATE 2.- DRAIN 3.- SOURCE 4.- DRAIN IGBTs, CoPACK 1.- GATE 2.- COLLECTOR 3.- EMITTER 4.- COLLECTOR DIODES 1.- ANODE/OPEN 2.- CATHODE 3.- ANODE
A1	.087	.102	2.21	2.59	
A2	.059	.098	1.50	2.49	
b	.039	.055	0.99	1.40	
b1	.039	.053	0.99	1.36	
b2	.065	.094	1.65	2.39	
b3	.065	.092	1.65	2.34	
b4	.102	.135	2.59	3.43	
b5	.102	.133	2.59	3.38	
c	.015	.035	0.38	0.89	
c1	.015	.033	0.38	0.84	
D	.776	.815	19.71	20.70	
D1	.515	-	13.08	-	
D2	.020	.053	0.51	1.35	
E	.602	.625	15.29	15.87	
E1	.530	-	13.46	-	
E2	.178	.216	4.52	5.49	
e	.215 BSC		5.46 BSC		
Øk	.010		0.25		
L	.559	.634	14.20	16.10	
L1	.146	.169	3.71	4.29	
ØP	.140	.144	3.56	3.66	
ØP1	-	.291	-	7.39	
Q	.209	.224	5.31	5.69	
S	.217 BSC		5.51 BSC		

TO-247AC Part Marking Information

Notes: This part marking information applies to devices produced after 02/26/2001

EXAMPLE: THIS IS AN IRFPE30
 WITH ASSEMBLY
 LOT CODE 5657
 ASSEMBLED ON WW 35, 2001
 IN THE ASSEMBLY LINE "H"

Note: "P" in assembly line position indicates "Lead-Free"

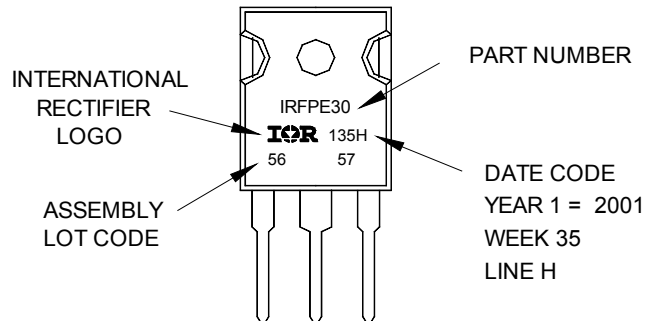

TO-247AC package is not recommended for Surface Mount Application.

TO-247AD Package Outline

Dimensions are shown in millimeters (inches)

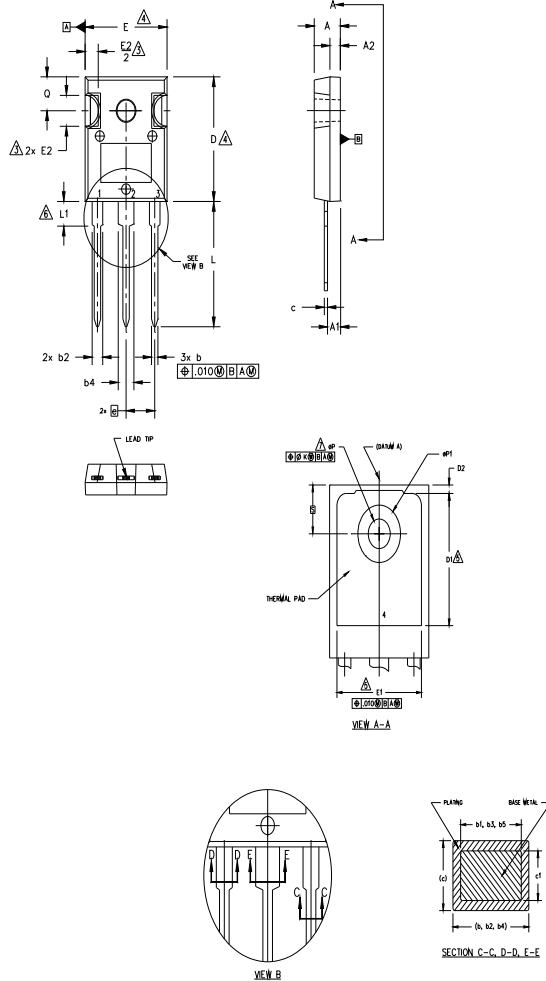

NOTES:

1. DIMENSIONING AND TOLERANCING AS PER ASME Y14.5M 1994.
2. DIMENSIONS ARE SHOWN IN INCHES.
3. CONTOUR OF SLOT OPTIONAL.
4. DIMENSION D & E DO NOT INCLUDE MOLD FLASH. MOLD FLASH SHALL NOT EXCEED .005" (0.127) PER SIDE. THESE DIMENSIONS ARE MEASURED AT THE OUTERMOST EXTREMES OF THE PLASTIC BODY.
5. THERMAL PAD CONTOUR OPTIONAL WITHIN DIMENSIONS D1 & E1.
6. LEAD FINISH UNCONTROLLED IN L1.
7. ϕP TO HAVE A MAXIMUM DRAFT ANGLE OF 1.5° TO THE TOP OF THE PART WITH A MAXIMUM HOLE DIAMETER OF .154 INCH.
8. OUTLINE CONFORMS TO JEDEC OUTLINE TO-247AD.

SYMBOL	DIMENSIONS				NOTES
	INCHES		MILLIMETERS		
	MIN.	MAX.	MIN.	MAX.	
A	.183	.209	4.65	5.31	
A1	.087	.102	2.21	2.59	
A2	.059	.098	1.50	2.49	
b	.039	.055	0.99	1.40	
b1	.039	.053	0.99	1.35	
b2	.065	.094	1.65	2.39	
b3	.065	.092	1.65	2.34	
b4	.102	.135	2.59	3.43	
b5	.102	.133	2.59	3.38	
c	.015	.035	0.38	0.89	
c1	.015	.033	0.38	0.84	
D	.776	.815	19.71	20.70	4
D1	.515	-	13.08	-	5
D2	.020	.053	0.51	1.35	
E	.602	.625	15.29	15.87	4
E1	.530	-	13.46	-	
E2	.178	.216	4.52	5.49	
e	.215 BSC		5.46 BSC		
ϕk	.010		0.25		
L	.780	.827	19.57	21.00	
L1	.146	.169	3.71	4.29	
ϕP	.140	.144	3.56	3.66	
$\phi P1$	-	.291	-	7.39	
Q	.209	.224	5.31	5.69	
S	.217 BSC		5.51 BSC		

LEAD ASSIGNMENTS

HEXFET

- 1.- GATE
- 2.- DRAIN
- 3.- SOURCE
- 4.- DRAIN

IGBTs, CoPACK

- 1.- GATE
- 2.- COLLECTOR
- 3.- EMITTER
- 4.- COLLECTOR

DIODES

- 1.- ANODE/OPEN
- 2.- CATHODE
- 3.- ANODE

TO-247AD Part Marking Information

EXAMPLE: THIS IS AN IRGP30B120KD-E
WITH ASSEMBLY
LOT CODE 5657
ASSEMBLED ON WW 35, 2000
IN THE ASSEMBLY LINE "H"

Note: "P" in assembly line position
indicates "Lead-Free"

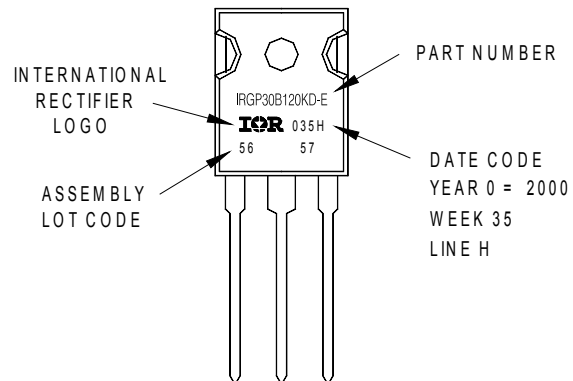

TO-247AD package is not recommended for Surface Mount Application.

D²-PAK (TO-263AB) Package Outline

Dimensions are shown in millimeters (inches)

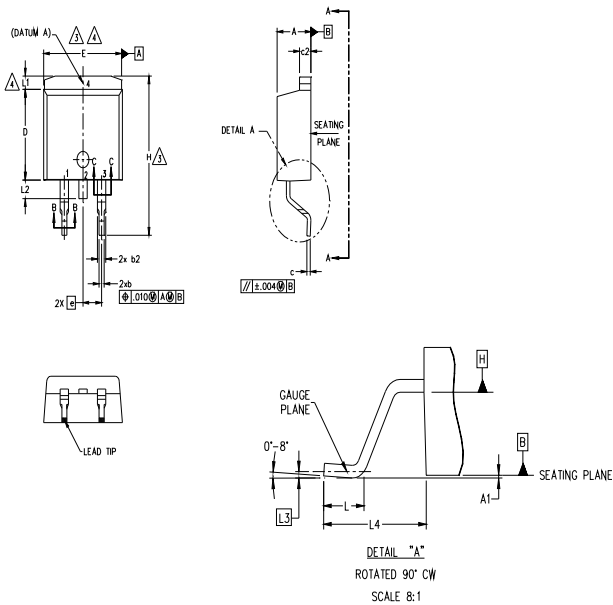

SYMBOL	DIMENSIONS				NOTES
	MILLIMETERS		INCHES		
	MIN.	MAX.	MIN.	MAX.	
A	4.06	4.83	.160	.190	
A1	0.00	0.254	.000	.010	
b	0.51	0.99	.020	.039	
b1	0.51	0.89	.020	.035	5
b2	1.14	1.78	.045	.070	
b3	1.14	1.73	.045	.068	5
c	0.38	0.74	.015	.029	
c1	0.38	0.58	.015	.023	5
c2	1.14	1.65	.045	.065	
D	8.38	9.65	.330	.380	3
D1	6.86	—	.270	—	4
E	9.65	10.67	.380	.420	3,4
E1	6.22	—	.245	—	4
e	2.54 BSC		.100 BSC		
H	14.61	15.88	.575	.625	
L	1.78	2.79	.070	.110	
L1	—	1.65	—	.066	4
L2	—	1.78	—	.070	
L3	0.25 BSC		.010 BSC		
L4	4.78	5.28	.188	.208	

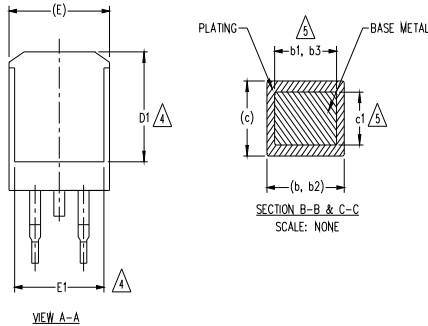

LEAD ASSIGNMENTS

- DIODES**
- 1.- ANODE (TWO DIE) / OPEN (ONE DIE)
 - 2.- CATHODE
 - 3.- ANODE
- HEXFET**
- 1.- GATE
 - 2.- DRAIN
 - 3.- SOURCE
- IGBTs, CoPACK**
- 1.- GATE
 - 2.- COLLECTOR
 - 3.- EMITTER

NOTES:

1. DIMENSIONING AND TOLERANCING PER ASME Y14.5M-1994
2. DIMENSIONS ARE SHOWN IN MILLIMETERS [INCHES].
3. DIMENSION D & E DO NOT INCLUDE MOLD FLASH. MOLD FLASH SHALL NOT EXCEED 0.127 [0.005"] PER SIDE. THESE DIMENSIONS ARE MEASURED AT THE OUTMOST EXTREMES OF THE PLASTIC BODY AT DATUM H.
4. THERMAL PAD CONTOUR OPTIONAL WITHIN DIMENSION E, L1, D1 & E1.
5. DIMENSION b1 AND c1 APPLY TO BASE METAL ONLY.
6. DATUM A & B TO BE DETERMINED AT DATUM PLANE H.
7. CONTROLLING DIMENSION: INCH.
8. OUTLINE CONFORMS TO JEDEC OUTLINE TO-263AB.

D²-Pak (TO-263AB) Part Marking Information

EXAMPLE: THIS IS AN IRF530S WITH LOT CODE 8024 ASSEMBLED ON WW 02, 2000 IN THE ASSEMBLY LINE "L"

Note: "P" in assembly line position indicates "Lead - Free"

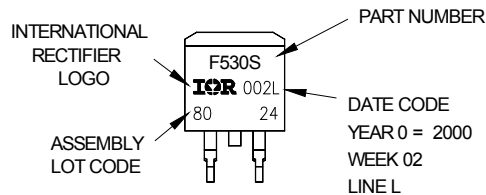

OR

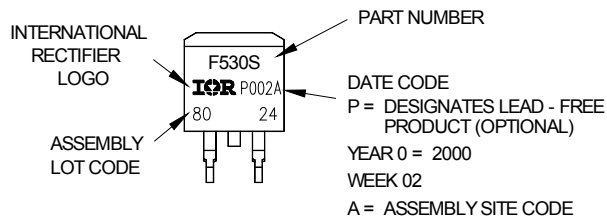

D²Pak Tape & Reel Information

(Dimensions are shown in millimeters (inches))

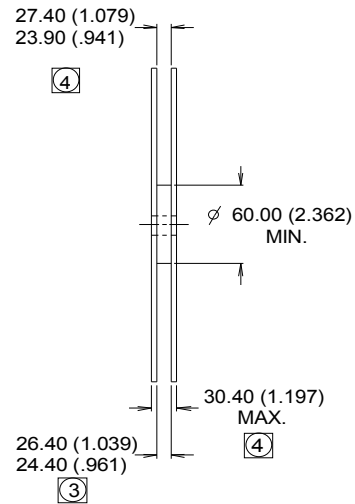
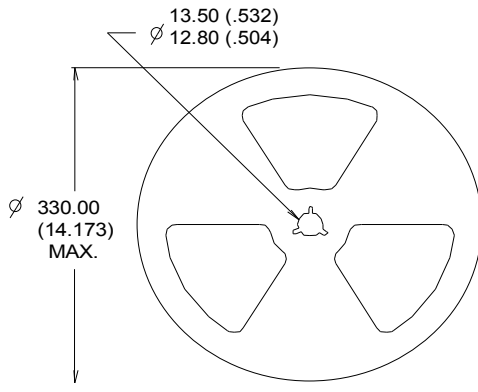
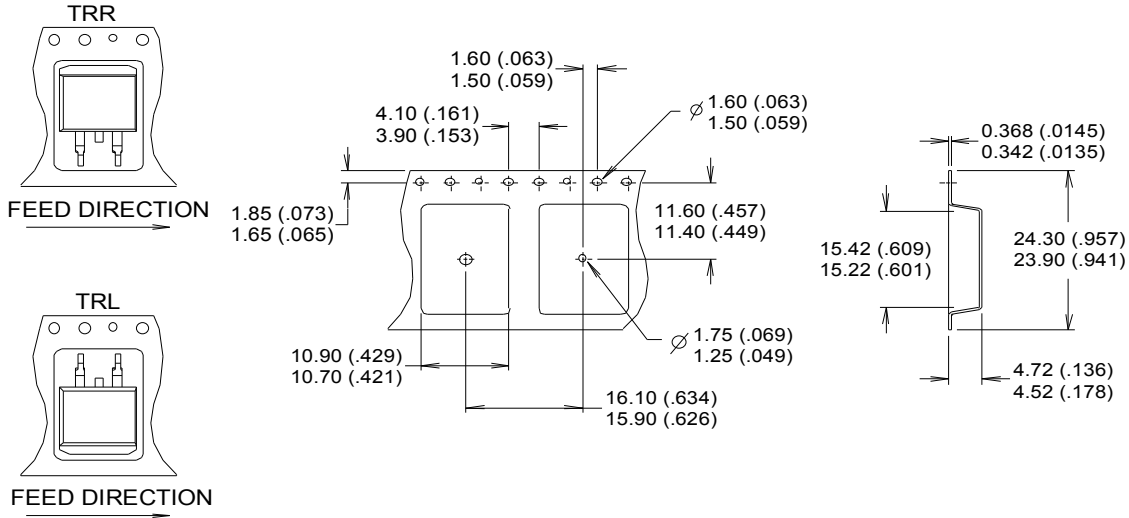

- NOTES :
1. COMFORMS TO EIA-418.
 2. CONTROLLING DIMENSION: MILLIMETER.
 3. DIMENSION MEASURED @ HUB.
 4. INCLUDES FLANGE DISTORTION @ OUTER EDGE.

Qualification Information[†]

Qualification Level	Industrial (per JEDEC JESD47F) ^{††}	
Moisture Sensitivity Level	TO-220AB	N/A
	TO-220AB-Full-Pak	
	TO-247AC	
	TO-247AD	
	D ² Pak	MSL1
RoHS Compliant	Yes	

† Qualification standards can be found at International Rectifier's web site: <http://www.irf.com/product-info/reliability/>

†† Applicable version of JEDEC standard at the time of product release.

Published by
Infineon Technologies AG
81726 München, Germany
© Infineon Technologies AG 2015
All Rights Reserved.

IMPORTANT NOTICE

The information given in this document shall in no event be regarded as a guarantee of conditions or characteristics ("Beschaffheitsgarantie"). With respect to any examples, hints or any typical values stated herein and/or any information regarding the application of the product, Infineon Technologies hereby disclaims any and all warranties and liabilities of any kind, including without limitation warranties of non-infringement of intellectual property rights of any third party.

In addition, any information given in this document is subject to customer's compliance with its obligations stated in this document and any applicable legal requirements, norms and standards concerning customer's products and any use of the product of Infineon Technologies in customer's applications.

The data contained in this document is exclusively intended for technically trained staff. It is the responsibility of customer's technical departments to evaluate the suitability of the product for the intended application and the completeness of the product information given in this document with respect to such application.

For further information on the product, technology, delivery terms and conditions and prices please contact your nearest Infineon Technologies office (www.infineon.com).

WARNINGS

Due to technical requirements products may contain dangerous substances. For information on the types in question please contact your nearest Infineon Technologies office.

Except as otherwise explicitly approved by Infineon Technologies in a written document signed by authorized representatives of Infineon Technologies, Infineon Technologies' products may not be used in any applications where a failure of the product or any consequences of the use thereof can reasonably be expected to result in personal injury.

Looking for pricing, stock, or lifecycle information?

Click below to explore more details on WIN SOURCE:

 [View IRGS4620DPBF on WIN SOURCE](#)

 [Infineon Technologies](#) Information

Optimize Your Supply Chain with WIN SOURCE Solutions

-  Global Sourcing Solution
-  Obsolete Management
-  Cost Control Management
-  Shortage Management
-  Alternative Solution
-  Excess Inventory Management