



THE DATASHEET OF INA260EVM



INA260EVM-PDK Rev A Model User's Guide and Software Tutorial



ABSTRACT

This user's guide describes the characteristics, operation, and use of the INA260EVM-PDK (Rev A) hardware. This user's guide discusses how to set up and configure the software and hardware, and reviews the device operation. Throughout this document, the terms *evaluation board*, *evaluation module*, *EVM PCB*, and *EVM* are synonymous with the INA260EVM. The terms *PDK*, *kit*, and *EVM kit* are synonymous with the INA260EVM-PDK. This user's guide also includes information regarding operating procedures, the input and output connections, an electrical schematic, printed circuit board (PCB) layout drawings, and a parts list for the EVM.

Table of Contents

1 Overview	2
1.1 INA260EVM-PDK Contents.....	2
1.2 INA260EVM-PDK Features.....	3
1.3 Related Documentation from Texas Instruments.....	3
2 INA260EVM-PDK Hardware	4
2.1 SM-USB-DIG Platform Description.....	5
2.2 INA260EVM PCB Description.....	6
2.3 EVM Digital Inputs and Outputs.....	8
3 INA260EVM-PDK (Rev A) Setup	9
3.1 One-Time GUI Software Installation.....	10
3.2 INA260EVM Jumper Settings.....	12
3.3 Connecting the Hardware.....	13
3.4 System Power-Up.....	15
4 INA260EVM GUI Software	16
4.1 Configuration Tool.....	17
4.2 Results Bar.....	20
4.3 Graph Tool.....	20
4.4 Registers Tool.....	21
5 INA260EVM Documentation	22
5.1 Schematic.....	23
5.2 PCB Layout.....	24
5.3 Bill of Materials.....	25
6 Revision History	26

Trademarks

Windows® is a registered trademark of Microsoft Corporation.
All trademarks are the property of their respective owners.

1 Overview

The [INA260](#) is a high- or low-side current sensor, power, and voltage monitor with a 2-m Ω precision integrated shunt resistor and I²C interface. The INA260 offers programmable conversion times and averaging modes that enable high resolution measurements of the current, voltage, and power dissipation of the monitored source.

The INA260EVM-PDK, which consists of the INA260EVM and SM-USB-DIG controller board, is a platform used to evaluate the features and performance of the INA260 under various signal and supply conditions. This document gives a general overview of the INA260EVM-PDK and describes the features and functions to consider when using this evaluation module.

1.1 INA260EVM-PDK Contents

[Table 1-1](#) summarizes the contents of the INA260EVM kit. [Figure 1-1](#) shows all included hardware. Contact the [Texas Instruments customer support center](#) if any component is missing.

Note

This EVM kit requires the INA260EVM GUI software, which is available for download through the [INA260 design & development](#) folder. TI recommends users check the [INA260 product folder](#) on the TI website at www.ti.com to verify that they have the latest versions of the related software.

Table 1-1. INA260EVM Kit Contents

ITEM	QUANTITY
INA260EVM PCB test board	1
SM-USB-DIG platform PCB	1
USB extender cable	1



Figure 1-1. Hardware Included with the INA260EVM Kit

1.2 INA260EVM-PDK Features

- USB-powered; no external power supply is required
- Support for full $\pm 15\text{-A}$ input current range and 36-V common-mode voltage range of the INA260
- EVM includes placeholders for transient voltage suppression (TVS) devices to protect the INA260 inputs from excessively high common-mode voltages
- Digital host controller included
- Intuitive GUI software supports all major INA260 functional modes and simplifies device configuration

Note

To protect against voltage transients that may exceed the absolute maximum ratings, TI highly recommends installing the TVS devices (D3 and D4, as shown in [Figure 1-2](#)) with a minimum power rating of 1000 W to clamp the input voltages to less than 36 V.

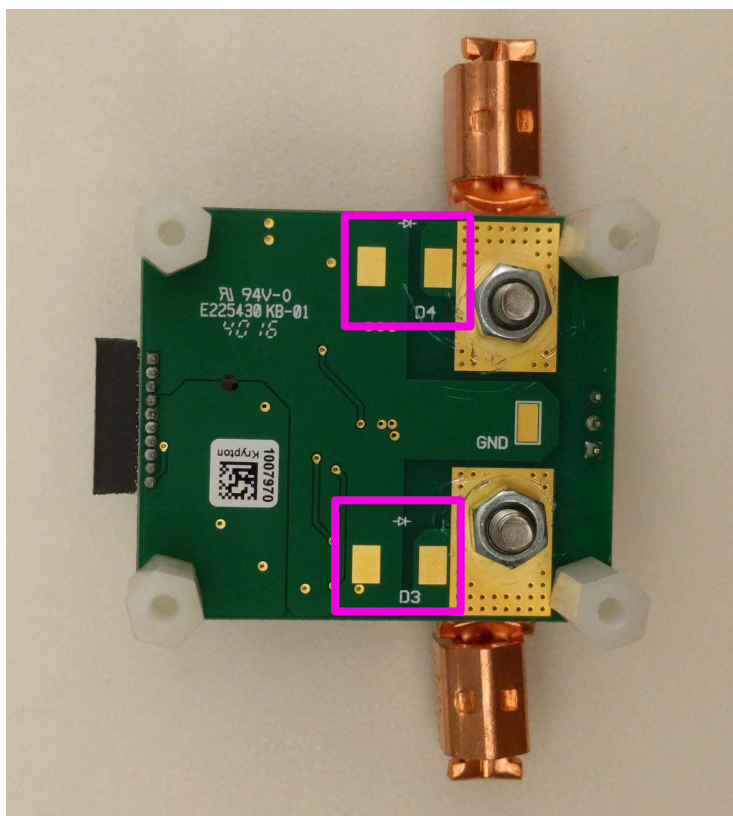

Figure 1-2. Placeholders for TVS Devices

1.3 Related Documentation from Texas Instruments

The following documents provide information regarding Texas Instruments' integrated circuits used in the assembly of the INA260EVM. This user's guide is available from the TI web site under literature number *SBOU180*. Any letter appended to the literature number corresponds to the document revision that is current at the time of the writing of this document. Newer revisions may be available from www.ti.com, or call the Texas Instruments' Literature Response Center at (800) 477-8924 or the Product Information Center at (972) 644-5580. When ordering, identify the document by both title and literature number.

Table 1-2. Related Documentation

DOCUMENT	LITERATURE NUMBER
INA260 product data sheet	SBOS656
SM-USB-DIG platform user guide	SBOU098

2 INA260EVM-PDK Hardware

Figure 2-1 shows the overall system setup for the INA260EVM-PDK. To monitor the power source, connect the power source to the EVM input terminals. The computer runs the GUI software that enables power to the INA260 and communicate with the device. The user can send commands through the USB port of the computer to the SM-USB-DIG board to translate these commands into I²C format before sending the commands to the EVM.

With power enabled, the INA260 responds to these I²C commands by sending the requested data back to the SM-USB-DIG board over the I²C. The SM-USB-DIG converts the received data to USB format and sends the data back to the computer, where it is then appropriately processed and displayed to the user.

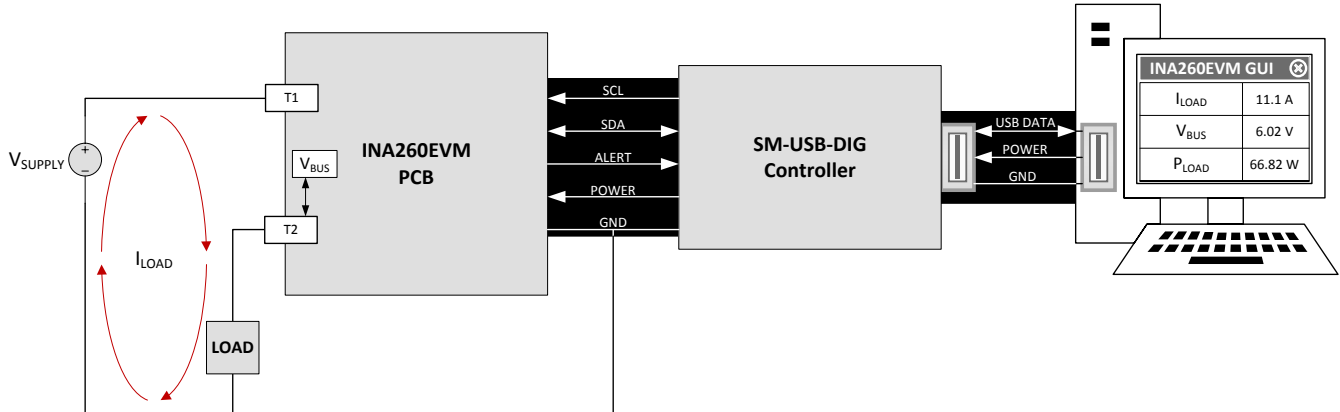

Figure 2-1. INA260EVM-PDK Hardware Setup

2.1 SM-USB-DIG Platform Description

Figure 2-2 shows the block diagram for the SM-USB-DIG platform. This platform is a general-purpose data acquisition system that is used on other Texas Instruments evaluation modules. The details of operation are included in a separate document, [SBOU098](#) (available for download at www.ti.com).

The [TUSB3210](#) is the primary control device for the SM-USB-DIG Platform. The TUSB3210 is an 8052 microcontroller that converts data received on the built-in USB interface to the I²C, SPI, and other serial digital I/O patterns. This EVM uses the I²C interface of the TUSB3210 to control the INA260.

Power supply for the SM-USB-DIG is derived from the USB interface. The SM-USB-DIG includes an onboard low dropout (LDO) regulator that uses the 5-V USB supply from the computer to generate a 3.3-V supply, which is then used to power all the active circuitry on board. The 3.3-V regulated supply can also be used to power the EVM PCB. In fact, the raw 5-V USB supply as well as the 3.3-V regulated supply are routed to a 2-input power MUX on the SM-USB-DIG, the [TPS2115A](#), whose output terminates at the V_{DUT} pin of the 10-pin EVM connector, intended to be used as the EVM power supply. The user can select between the 5-V and 3.3-V options for V_{DUT} through the INA260EVM GUI software.

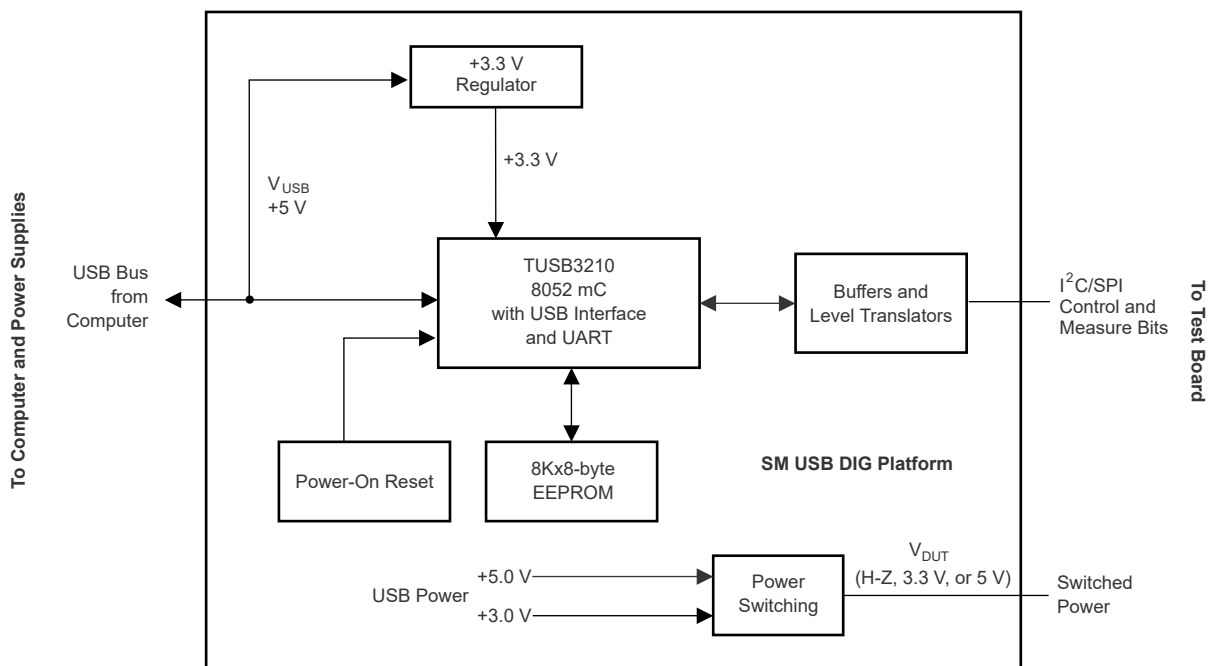

Figure 2-2. SM-USB-DIG Platform Block Diagram

2.2 INA260EVM PCB Description

Figure 2-3 depicts a block diagram of the INA260EVM PCB highlighting the power supplies, analog inputs, and digital I/O signals.

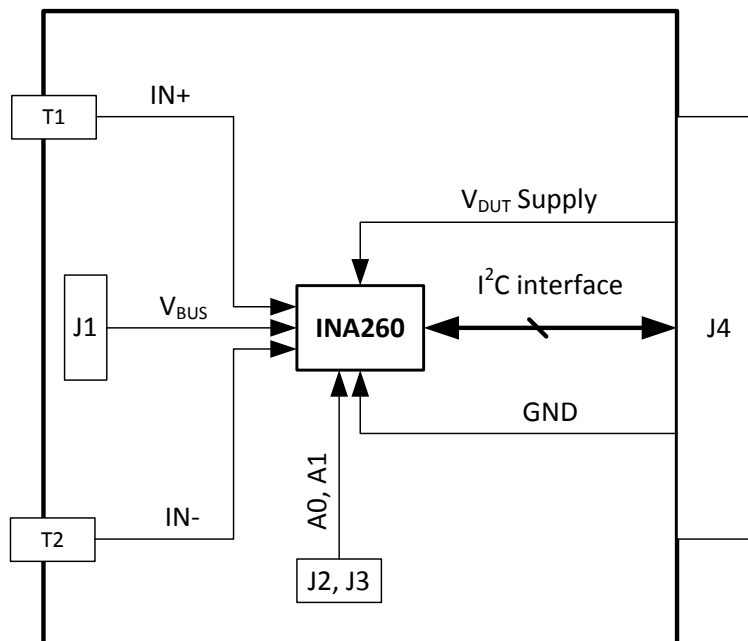

Figure 2-3. INA260EVM Block Diagram

The EVM PCB requires minimal instrumentation to be operated. In fact, the only pieces of required equipment not included in the kit are a (Windows[®] 7) computer and an input current source. All other inputs are supplied by the SM-USB-DIG board, via the 10-pin connector socket, J4. Table 2-1 lists the pinout for J4.

Table 2-1. Signal Definition of J4 on INA260EVM Board

PIN ON J4	SIGNAL	DESCRIPTION
10	I2C_SCL	I ² C clock signal (SCL)
9	CTRL/MEAS4	GPIO: control output or measure input
8	I2C_SDA1	I ² C data signal (SDA)
7	CTRL/MEAS5	GPIO: control output or measure input
6	SPI_DOUT1	SPI data output (MOSI)
5	V _{DUT}	Switchable DUT power supply: 3.3 V, 5 V, Hi-Z (disconnected) ⁽¹⁾
4	SPI_CLK	SPI clock signal (SCLK)
3	GND	Power return (GND)
2	SPI_CS1	SPI chip-select signal (\bar{CS})
1	SPI_DIN1	SPI data input (MISO)

(1) When V_{DUT} is Hi-Z, all digital I/Os are Hi-Z as well.

2.2.1 EVM Power Supply

The INA260EVM PCB uses the V_{DUT} and GND lines from the SM-USB-DIG (via J4) as the high and low supply voltages for the INA260. As noted in Table 2-1, the available supply voltages for V_{DUT} are 5 V and 3.3 V. The EVM supply voltage is user-selectable through the GUI. Place the 1- μ F ceramic capacitor (C2) in close proximity to the INA260 supply pin (U1) to provide adequate decoupling to V_{DUT} for power supply rejection at higher frequencies.

2.2.2 EVM Analog Inputs

The INA260 accepts two kinds of analog inputs: namely, a current through the internal shunt resistor and a voltage between the V_{BUS} pin and GND. Configure the INA260 in the GUI to digitize either one or both of these inputs in serial order. The high current lug connectors designated T1 and T2 are the terminations of the internal 2-m Ω shunt resistor, therefore connect T1 and T2 in series with the input current source and load (see [Figure 2-1](#)). The INA260 is a bidirectional device and thus current can flow through the shunt resistor in either direction.

CAUTION



Do Not Exceed the Absolute Maximum Ratings (see the [INA260 datasheet](#))!

To help ensure safe operating conditions, do not exceed the following electrical ratings:

- 15 A between connectors T1 and T2 in either direction
- 36 Vdc between T1 and GND
- 36 Vdc between T2 and GND

WARNING



Potential Burn Hazard!

To minimize risk of burn, do not touch U1 (the INA260 device) when input current is present. Temperatures higher than 50°C are possible.

The V_{BUS} input of the INA260 is accessible through pin 2 of header J1. Pins 1 and 3 of J1 are connected to IN+ and IN–, respectively. Note that the V_{BUS} input is independent of the current input (that is, the V_{BUS} input can be applied with or without a load), and the INA260 provides an accurate voltage reading. However, the device also passively multiplies the measured values of V_{BUS} and input current to generate a power value. For the power calculation to be meaningful, V_{BUS} must represent the voltage drop created by the input current across the load. Therefore, for accurate load power measurements, short the V_{BUS} pin to IN+ or IN– (on header J1) depending on the location of the load. For example, for the arrangement in [Figure 2-1](#), short V_{BUS} to IN– for an accurate load power calculation.

The EVM PCB also includes placeholders for the TVS devices to protect the INA260 inputs from excessively high common-mode voltages. The pads for these uninstalled devices, D3 and D4, are located on the bottom side of the EVM PCB and are suitable for DO-214AB package.

2.3 EVM Digital Inputs and Outputs

The only digital input signals required to operate the INA260 are the 2-bit I²C device address (A[1:0]), serial clock (SCL), and serial data (SDA), which is a bidirectional pin and thus also an output. The device address bits can each assume one of four values: GND, V_S, SDA or SCL, resulting in 16 possible target addresses summarized in [Table 2-2](#). The values of A0 and A1 must be set using jumpers J2 and J3, respectively.

Table 2-2. INA260 I²C Address Configuration

A1	A0	TARGET ADDRESS
GND	GND	1000000
GND	V _{S+}	1000001
GND	SDA	1000010
GND	SCL	1000011
V _{S+}	GND	1000100
V _{S+}	V _{S+}	1000101
V _{S+}	SDA	1000110
V _{S+}	SCL	1000111
SDA	GND	1001000
SDA	V _{S+}	1001001
SDA	SDA	1001010
SDA	SCL	1001011
SCL	GND	1001100
SCL	V _{S+}	1001101
SCL	SDA	1001110
SCL	SCL	1001111

The SM-USB-DIG drives the SCL and SDA through the J4 connector socket. These are open-drain inputs and the EVM contains pullup resistors to drive these inputs high when the corresponding SM-USB-DIG digital outputs are in tri-state. Both fast (1 kHz to 400 kHz) and high-speed (1 kHz to 2.94 MHz) I²C modes are supported.

The outputs of the INA260 include SDA and ALERT, both of which are routed to J4 and are readable from the GUI. The GUI includes support for both over- and underlimit as well as conversion ready indicator modes of the ALERT pin. The state of the ALERT pin can be read from either the GUI or the onboard LED indicator.

3 INA260EVM-PDK (Rev A) Setup

CAUTION

Components of the INA260EVM-PDK are susceptible to damage by electrostatic discharge (ESD). Customers are advised to observe proper ESD handling precautions when unpacking and handling the EVM, including the use of a grounded wrist strap at an approved ESD workstation.

The INA260EVM-PDK (Rev A) hardware setup involves the following sequence of operations:

1. Perform a one-time GUI software installation
2. Configure the EVM jumpers
3. Connect the hardware
4. Power up the EVM and input source

3.1 One-Time GUI Software Installation

The GUI software must be installed on a computer running Windows XP or later. Windows 7 is the recommended operating system.

Note

For the GUI text to be rendered correctly, the text size under *Control Panel >> Appearance and Personalization >> Display* (shown in [Figure 3-1](#)) must be set to **Smaller - 100%**.

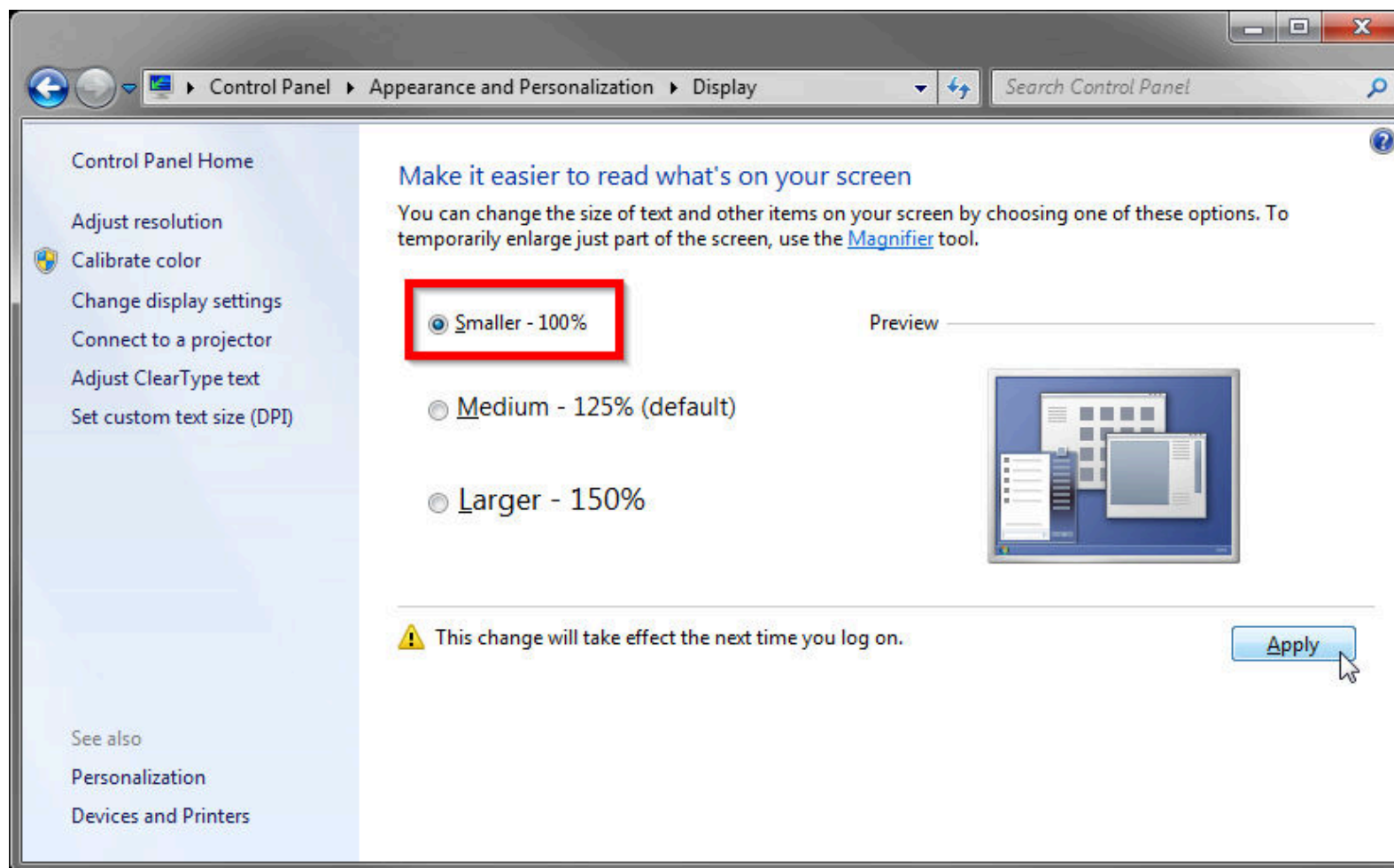

Figure 3-1. Recommended Display Settings

Make sure the hardware is not connected to the computer. Download the INA260EVM GUI from the [INA260 Tools & Software](#) folder. Extract the contents of the downloaded .zip file and run *Setup_INA260EVM.exe*. Follow the on-screen instructions provided in [Figure 3-2](#) to complete the software installation.

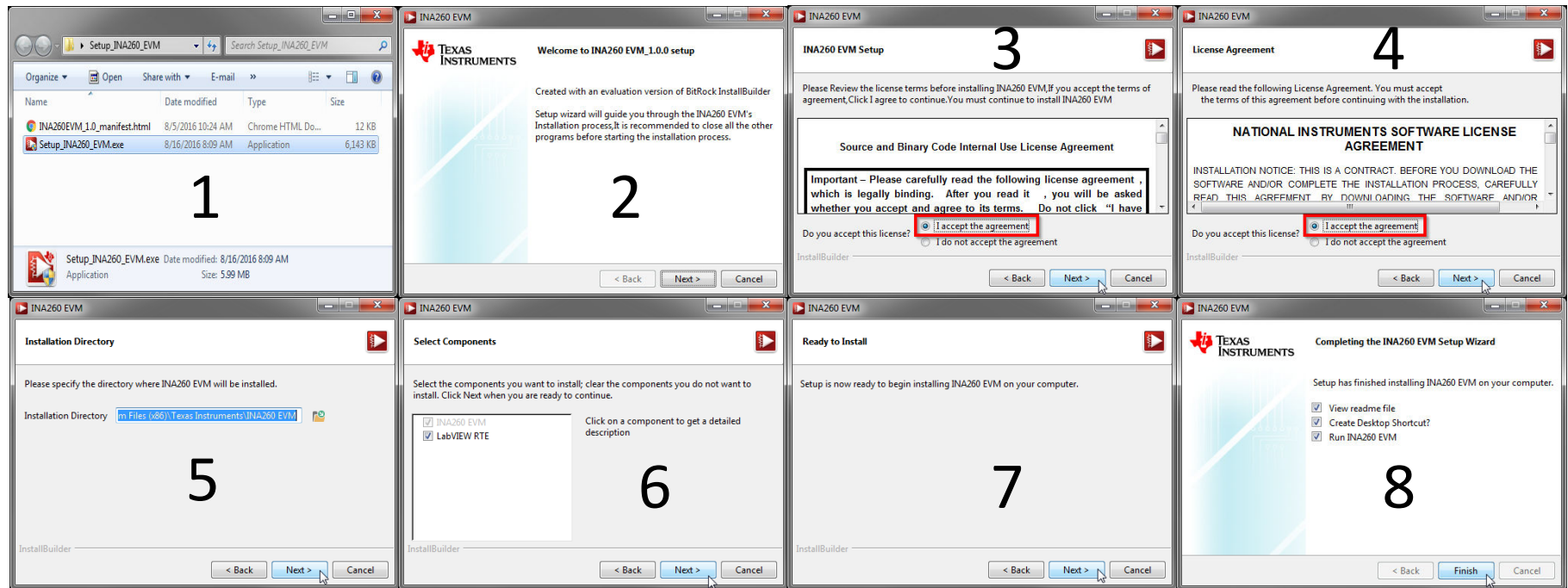

Figure 3-2. INA260EVM GUI Installation

3.2 INA260EVM Jumper Settings

Figure 3-3 shows the default jumper configuration for the INA260EVM and Table 3-1 explain the purpose of each jumper. Ensure that the jumpers are installed in the correct positions, based on the required test conditions.

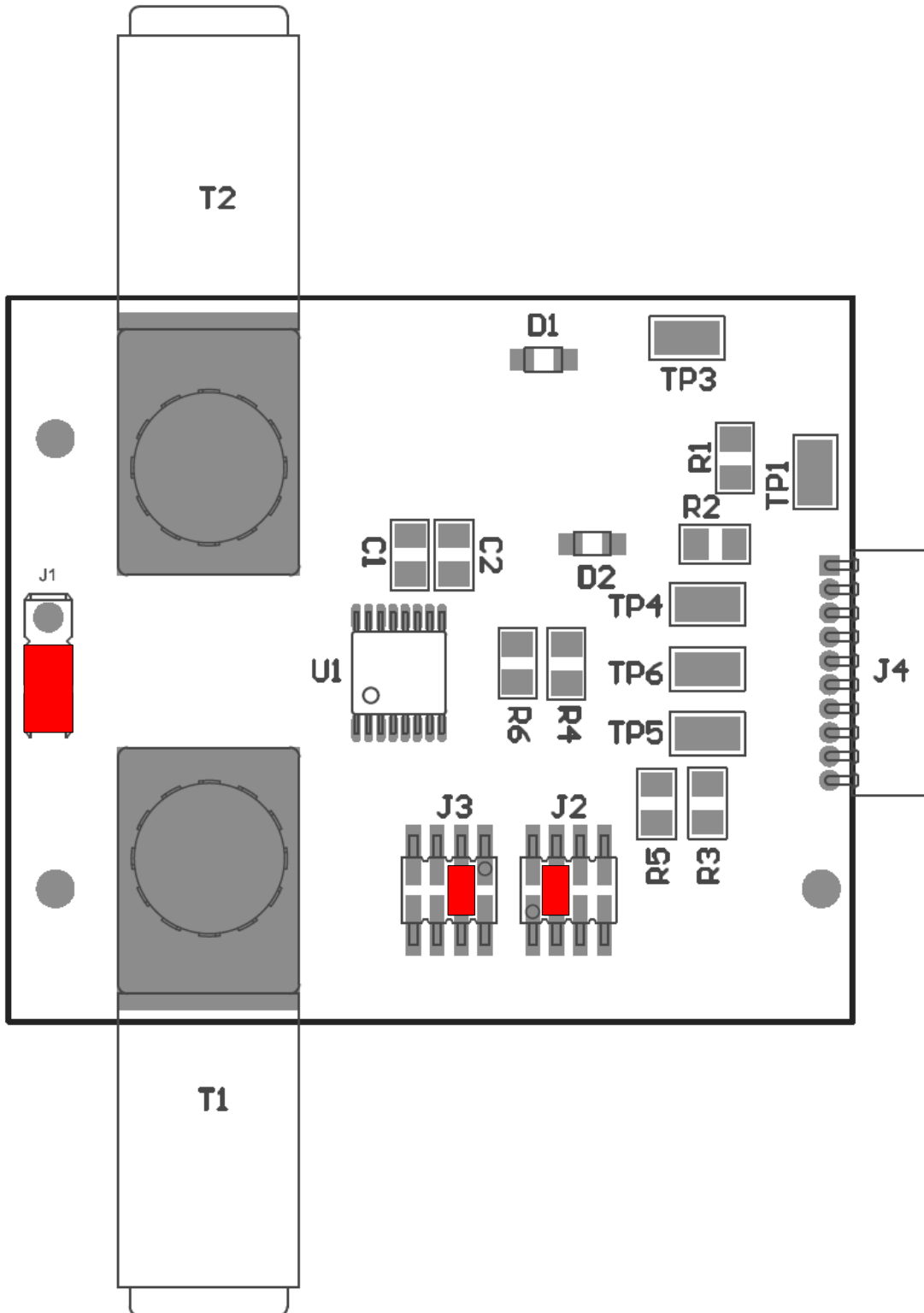

Figure 3-3. INA260EVM Default Jumper Settings

Table 3-1. INA260EVM Test Board Jumper Functions

JUMPER	DEFAULT	PURPOSE
J1	IN+	This jumper selects whether the V_{BUS} pin on the INA260 is connected to the IN+ or IN- pin; see Section 2.2.2 for details.
J2	GND	This jumper sets the A0 character of the 2-character I ² C device address; see Section 2.3 for details.
J3	GND	This jumper sets the A1 character of the 2-character I ² C device address; see Section 2.3 for details.

3.3 Connecting the Hardware

WARNING

To minimize risk of potential electrical shock hazard, be sure the EVM is full deenergized.

Before connecting the boards, make sure the high current lug connectors (T1 and T2) are tightly secured to the EVM PCB for low contact resistance. To minimize risk of potential electrical shock hazard, deenergize EVM followed by use of a screw-driver, while clasping the nut on the PCB bottom side with a crescent wrench.

Note

It may be necessary to uninstall the nylon standoffs near the lug connectors before manipulating the fasteners to avoid damaging them.

Connect the INA260EVM to the SM-USB-DIG board in the proper orientation, as shown in [Figure 3-4](#). Make sure that the two connectors are completely pushed together; loose connections can cause intermittent operation.

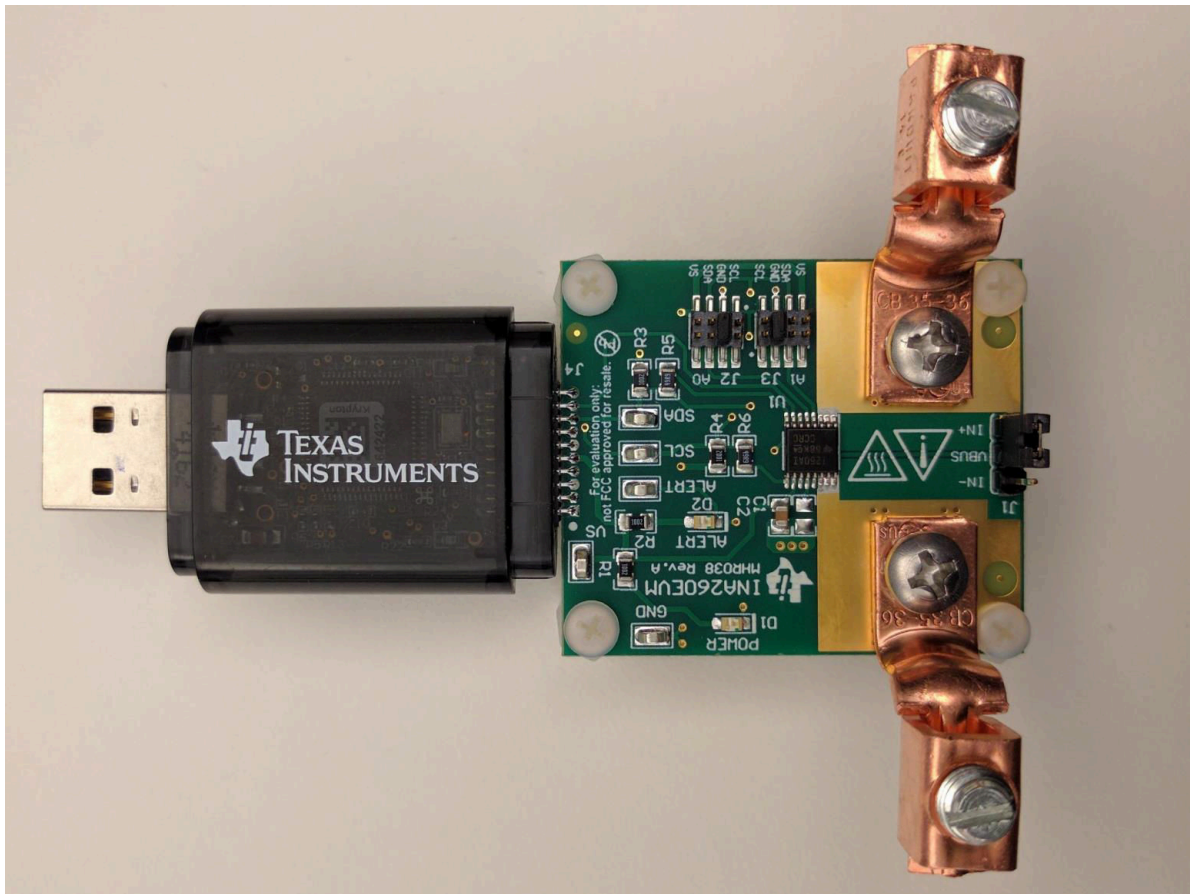

Figure 3-4. INA260EVM and SM-USB-DIG Connected in Proper Orientation

Next, with the output disabled, connect the input current source to the EVM via T1 and T2, as shown in [Figure 3-5](#).

Note

The lug connectors can accommodate wire sizes up to #6-AWG.

Also be sure to connect the low-side terminal of the input current source to EVM ground (GND) using one of the test points. This step is important to obtain accurate V_{BUS} measurements.

Lastly, connect the SM-USB-DIG to the computer, using the included USB extender cable if necessary. At this point the SM-USB-DIG powers on, but the EVM does not.

The power supply to the EVM must be enabled from the GUI.

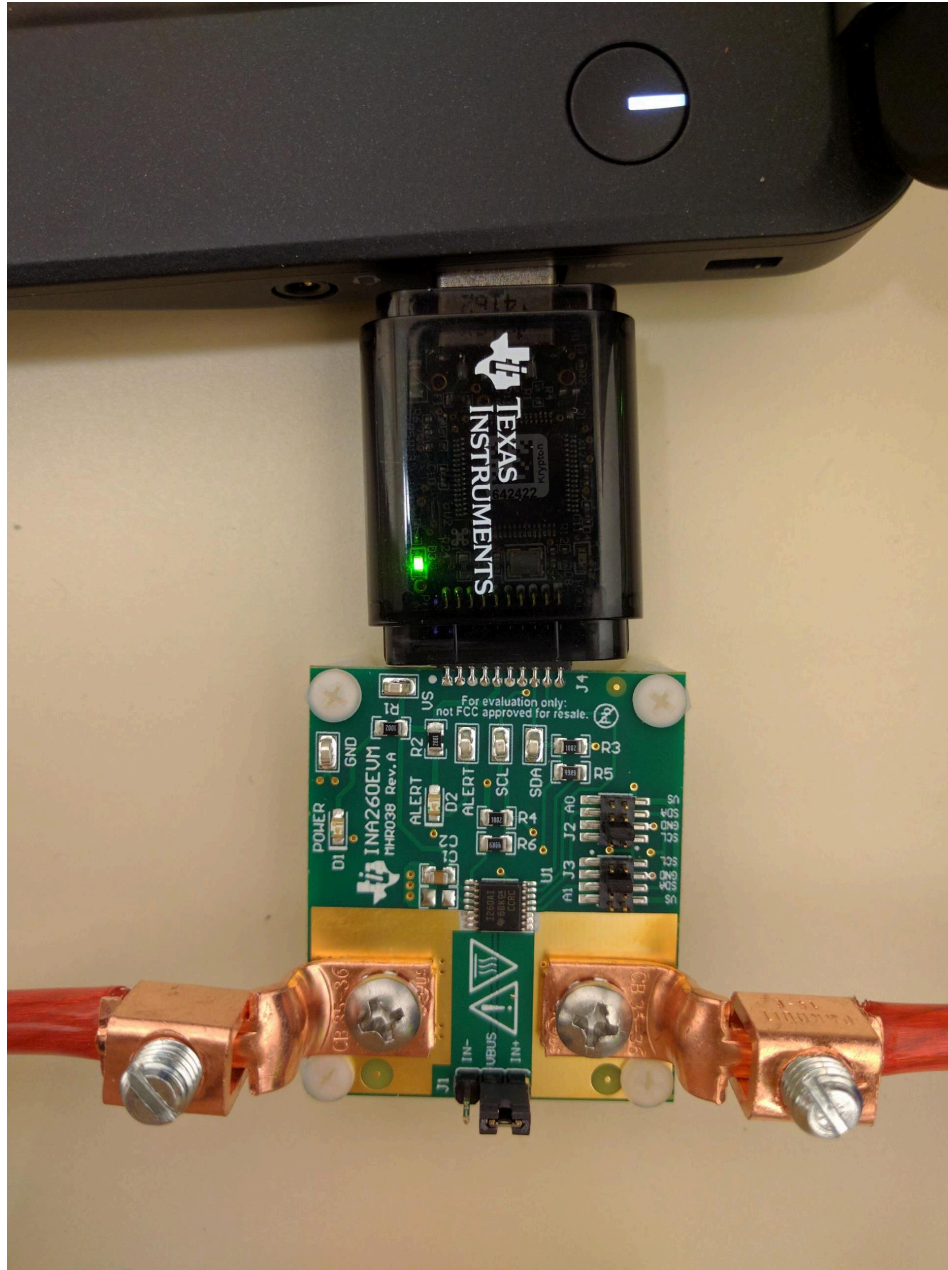

Figure 3-5. SM-USB-DIG Powers on When Connected to a Computer

3.4 System Power-Up

Launch the INA260EVM GUI software. The Power button on the GUI is enabled by default, which allows the POWER LED on the EVM to immediately light up. The light shows that the EVM PCB is receiving power.

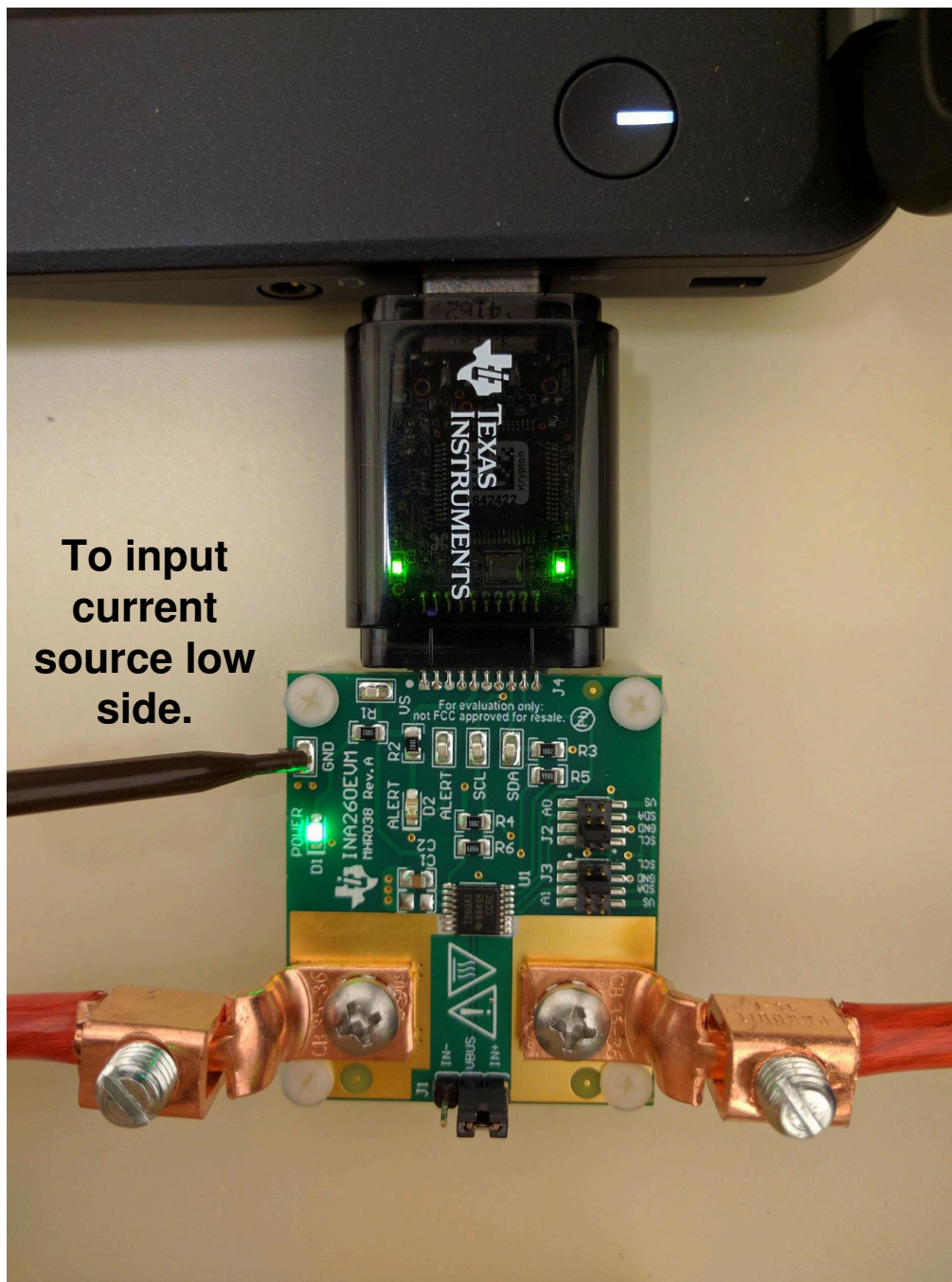

Figure 3-6. INA260EVM Powers Up Following the GUI Launch

Additionally, the supply voltage (V_{DUT}) is set to 3.3 V by default, but the user can select the 5-V option, if necessary (see [Figure 3-7](#)).



Figure 3-7. V_{DUT} Selection

With the INA260 powered on, the user can enable the analog input sources.

[Section 4](#) discusses the GUI configuration and data collection using this setup.

4 INA260EVM GUI Software

The INA260EVM GUI is a collection of software tools that make it easy for the user to explore the key behaviors of the INA260. The following tools are available:

- The *Configuration* tool simplifies the INA260 setup prior to evaluation testing
- The *Graph* tool plots the acquired data and exports to a file, if necessary
- The *Registers* tool displays and modifies the contents of the user-accessible registers

Each tool has a dedicated page under the corresponding tab on the GUI. The tabs are organized intuitively from left to right in the proper order, and the GUI always displays the *Configuration* page immediately after start-up. User can monitor measurement data under the *Results Bar* at the bottom of the GUI window. In most cases, (gross) testing can be performed using just the *Configuration* tool and the *Results Bar*; users may only need the *Graph* and *Registers* tools in special situations.

4.1 Configuration Tool

The Configuration tool allows the user to modify the operating conditions of the INA260 as required. User-specified settings are translated to I²C frames and written to the appropriate device registers whenever the user clicks the *Write All Reg* button. Equivalently, enabling the *Auto-Write* button causes immediate register updates whenever changes are detected. [Figure 4-1](#) shows the Configuration page of the GIU.

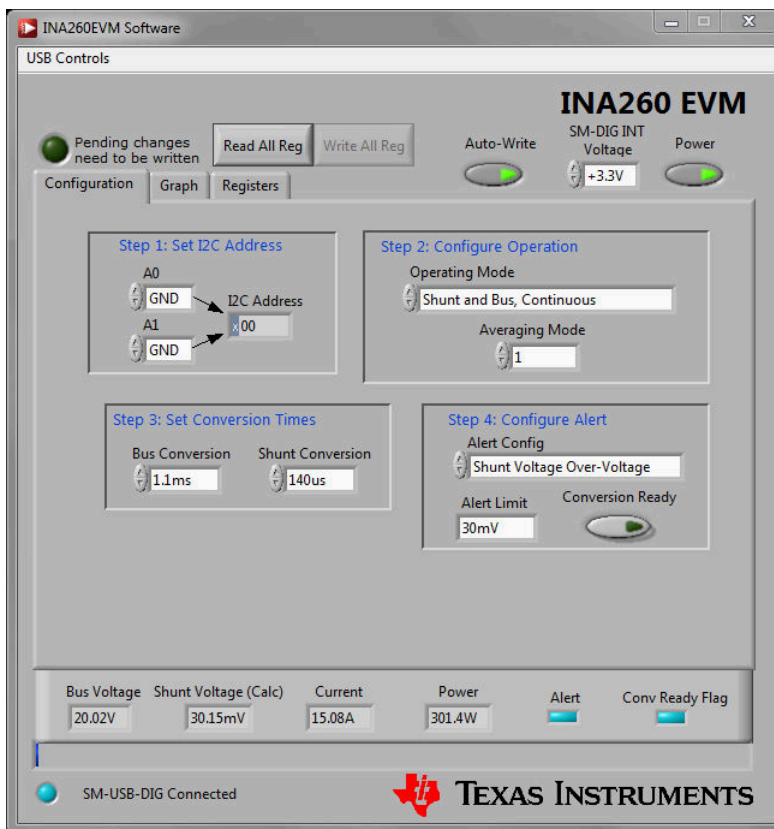

Figure 4-1. Configuration Page

4.1.1 Step 1: Set the I²C Address

The first step to configuring the INA260 from the EVM GUI is setting up communication. As indicated by [Table 2-2](#), the address bits A0 and A1 may represent up to 16 different INA260 devices communicating over a single I²C bus, where each device is identified by a unique target address. Therefore, step 1 involves selecting the correct A0 and A1 values that represent the target address of the INA260 installed on the EVM. In other words, the states of A0 and A1 in the GUI must match the jumper settings chosen for J2 and J3 on the EVM. The equivalent hexadecimal value of the target address is displayed in the box labeled *I²C Address* in [Figure 4-2](#).

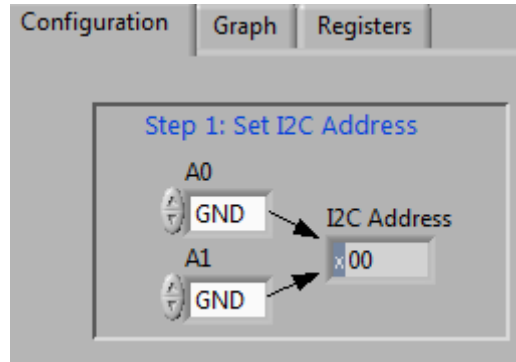

Figure 4-2. Target Address Setting

4.1.2 Step 2: Configure Operation

The INA260 offers multiple options for controlling the measurement process, including sequencing, triggering, averaging, as well as a power-down function. The associated control parameters can be specified in this section of the GUI.

[Figure 4-3](#) shows the options available under the *Operating Mode* menu. The default operating mode is *Shunt and Bus, Continuous*, which configures the INA260 to continuously measure the shunt current and bus voltage in serial order. The user can also set the INA260 to only measure the shunt current or bus voltage, but most applications benefit from measuring both signals.

Note

For maximum functionality, select a *Shunt and Bus* operating mode, as shown in [Figure 4-3](#).

Selecting any of the manual trigger modes allows the INA260 to only take measurements when the user clicks the *Write All Reg* button.

The *Power Down* mode stops all measurements from taking place until the operating mode changes again. The device remains attached to power but draws minimal supply current.

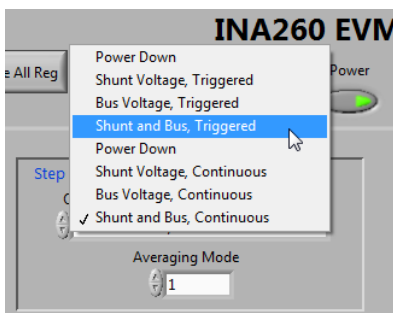

Figure 4-3. Operating Mode Menu

The *Averaging Mode* menu allows the user to select a desired number of samples for the INA260 averaging feature. This step configures the INA260 to compute and store the average value of the specified number of samples in the output register. The default value is 1.

4.1.3 Step 3: Set Conversion Times

Conversion time determines the sample rate of the INA260 internal ADC and can be programmed depending on the bandwidth of the input signal. The INA260 offers independent control of the conversion time for bus and shunt measurements. Step 3 provides drop-down menus from which suitable values can be selected, as shown in Figure 4-4.

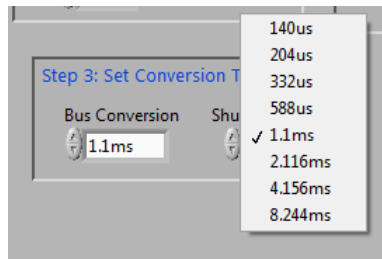

Figure 4-4. Configuring Conversion Times

4.1.4 Step 4: Configure Alert

The Alert pin allows the user to set limits on the value of the output register corresponding to the parameter selected from the drop-down menu, as shown in Figure 4-5. If at any time the register value violates the user-specified limit, a flag is triggered on the Alert pin. Note that the Alert pin is set to active low by default. Users can specify the limit value in the *Alert Limit* box.

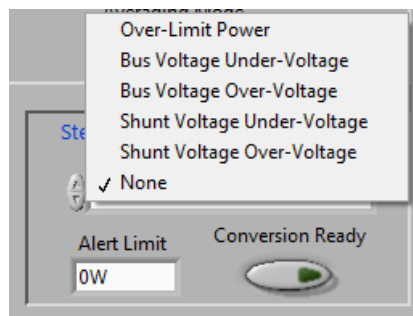

Figure 4-5. Configuring the Alert Pin

In addition to the INA260EVM software alert configuration, the *Alert Configuration* box includes the *Conversion Ready* button that allows for a special functionality on the Alert pin. When the INA260 completes the conversions for the current operation, the conversion triggers the Alert pin and notifies the user that another conversion can be performed. In most cases, the INA260 conversion ready flag is not visible because of the speed of the INA260 conversion process.

4.2 Results Bar

The contents of the INA260 output registers are appropriately scaled and displayed on the *Results Bar* located at the bottom of the GUI window, as shown in [Figure 4-6](#). The data displayed includes the states of the Alert and Conversion Ready flags. Users can click the *Read All Reg* button to update the results every time the output registers of the INA260 are read. Alternatively, users can enable the *Continuously Poll Data* button on the *Graph* tool page to read the output registers continuously.

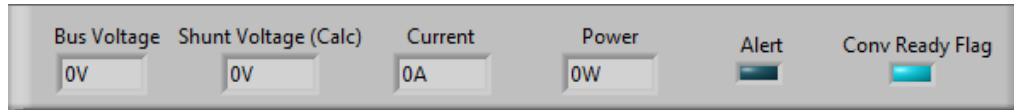

Figure 4-6. INA260 Results Bar

4.3 Graph Tool

The *Graph* tool buffers and plots measurement data over time, similar to an oscilloscope, as shown in [Figure 4-7](#). The Y-axis variable can be changed from the drop-down menu. Users can either click the *Read All Reg* button to update the plot or enable the *Continuously Poll Data* button to read the output registers continuously. Note that the output registers do not update until a new set of samples are acquired. To acquire new samples, click the *Write All Reg* button or configure the INA260 for continuous trigger mode.

Note

The recommended operating mode for using the *Graph* tool is *Shunt and Bus, Continuous*.

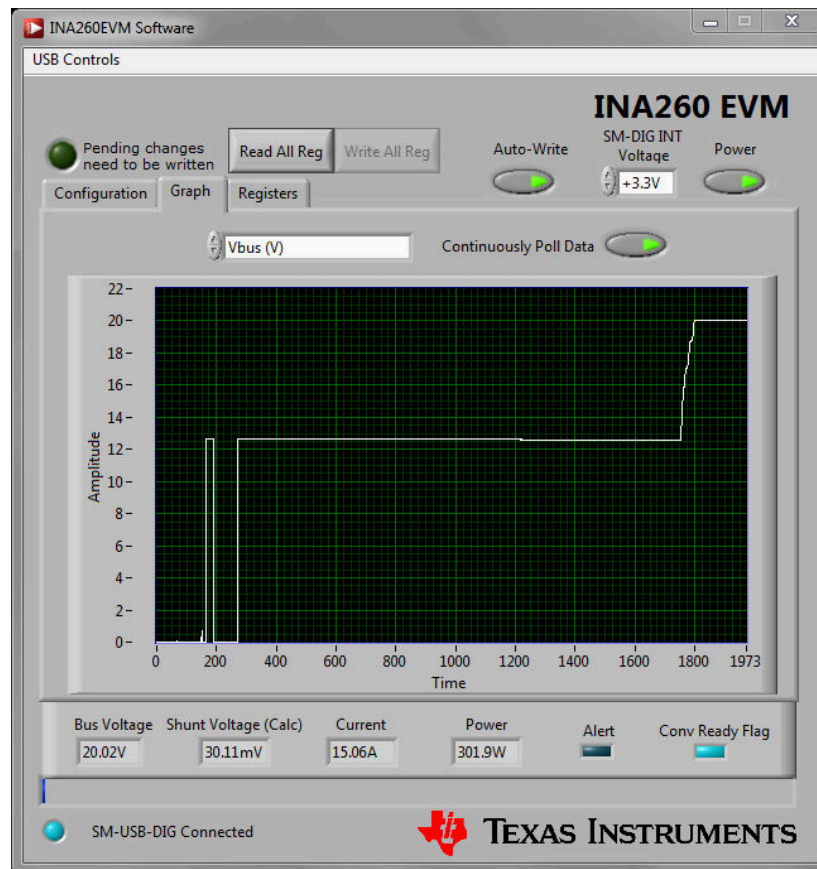

Figure 4-7. Graph Tool Page

4.4 Registers Tool

The *Registers* tool (as shown in [Figure 4-8](#)) allows the user to monitor and even change the contents of the internal user-accessible registers of the INA260 on a bit-by-bit basis. Bit names for the selected register are displayed on the lower panel of the page, but the user is advised to consult the [INA260 data sheet](#) for detailed bit definitions that may be necessary when modifying the contents of the input registers.

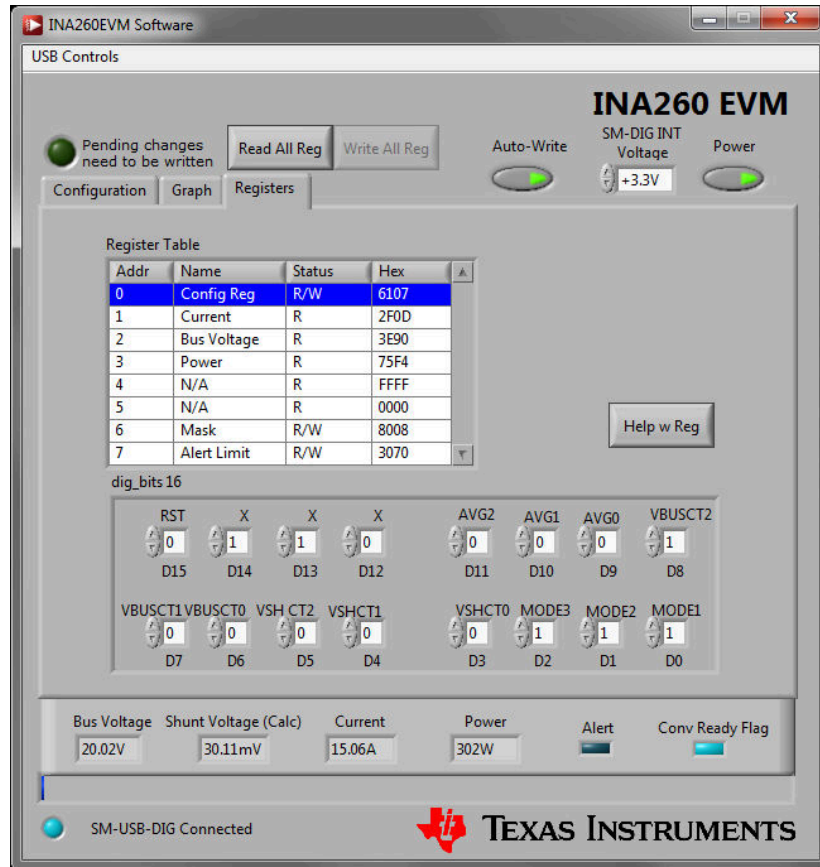

Figure 4-8. Registers Tool Page

5 INA260EVM Documentation

This section contains the complete bill of materials, schematic diagram, and PCB layout for the INA260EVM.

Note

The board layout is not to scale. This image is intended to show how the board is laid out and is not intended to be used for manufacturing INA260EVM PCBs.

5.1 Schematic

Figure 5-1 shows the schematic for the INA260EVM.

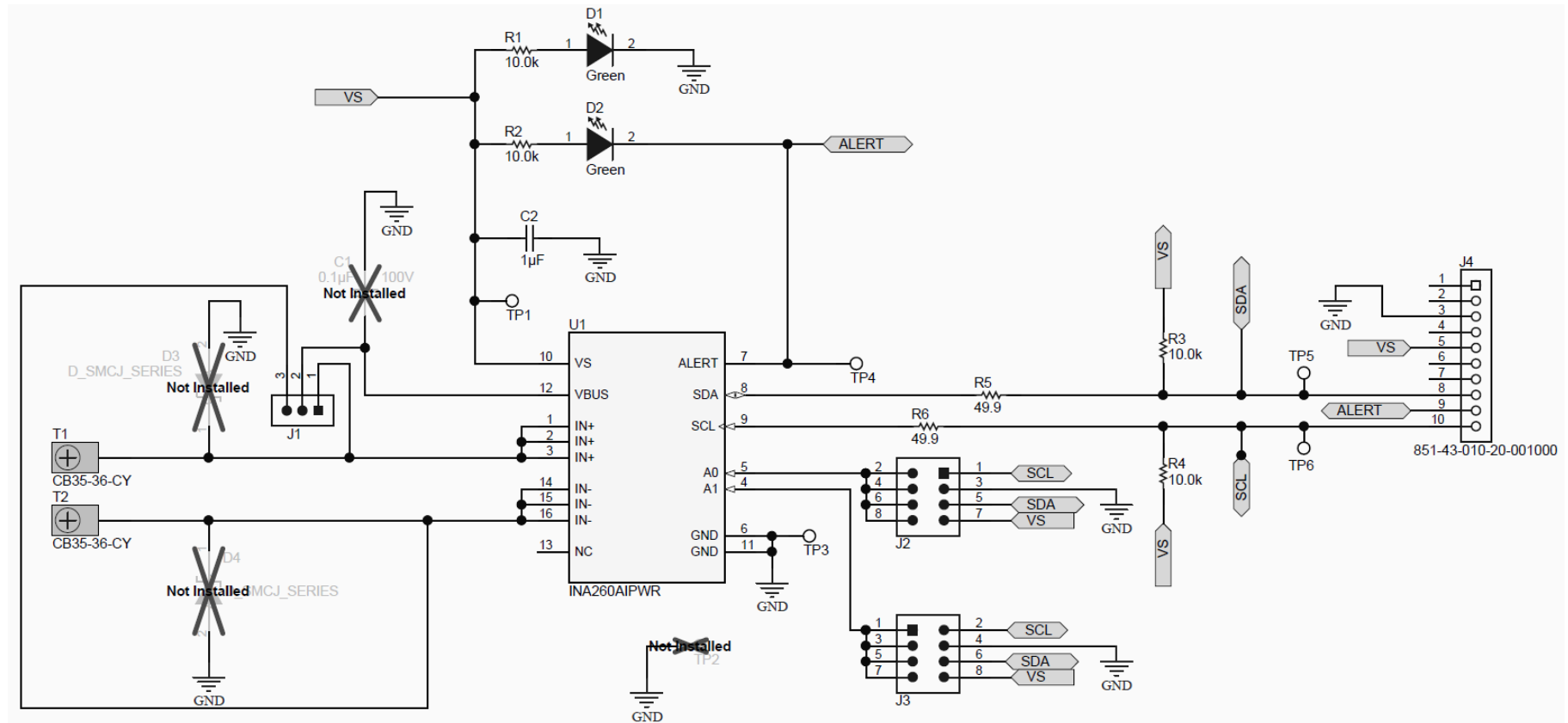

Figure 5-1. INA260EVM Schematic

5.2 PCB Layout

Figure 5-2 shows the component layout for the INA260EVM PCB.

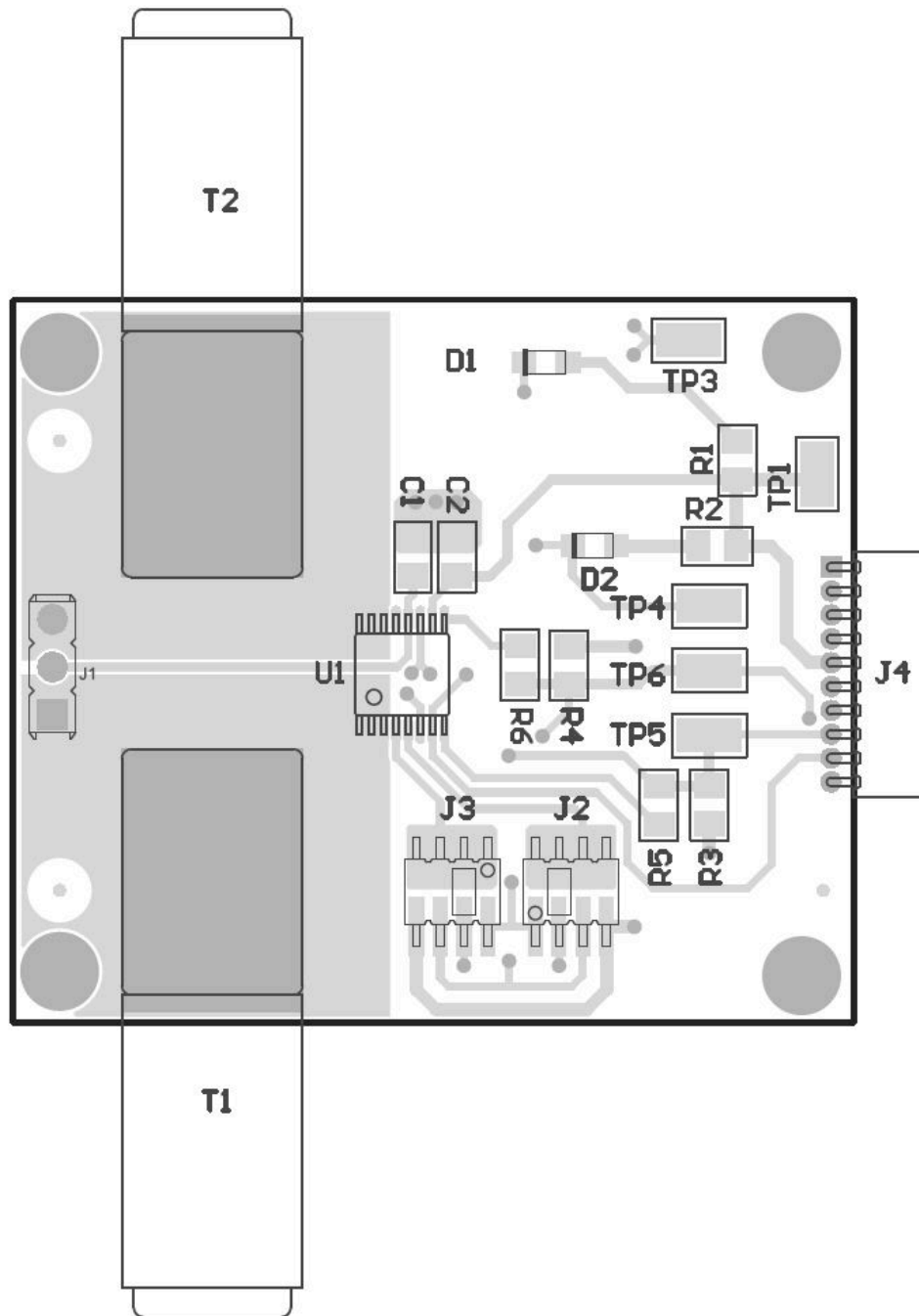

Figure 5-2. INA260EVM PCB Top Layer (Component Side)

5.3 Bill of Materials

Table 5-1 lists the bill of materials for the INA260EVM.

Table 5-1. Bill of Materials: INA260EVM

NO.	REF DES	DESCRIPTION	VENDOR OR MANUFACTURER	PART NUMBER
1	C2	CAP, CERM, 1 μ F, 50 V, +/- 10%, X7R, 0805	MuRata	GRM21BR71H105KA12L
2	D1, D2	LED, Green, SMD	Kingbright	APT2012LZGCK
3	J1	Header, 2.54mm, 3x1, Tin, TH	Harwin Inc	M20-9990345
4	J4, J5	Header, 50mil, 4x2, Gold, SMT	Amphenol FCI	20021121-00008C4LF
5	J6	Receptacle, 50mil, 10x1, Gold, R/A, TH	Mill-Max	851-43-010-20-001000
6	R1, R2, R3, R4	RES, 10.0 k, 1%, 0.125 W, 0805	Vishay-Dale	CRCW080510K0FKEA
7	R5, R6	RES, 49.9, 1%, 0.125 W, 0805	Vishay-Dale	CRCW080549R9FKEA
8	T1, T2	Terminal 50A Lug	Panduit	CB35-36-CY
9	TP1, TP3, TP4, TP5, TP6	Test Point, Miniature, SMT	Keystone	5015
10	U1	Integrated Shunt High-Side or Low-Side Measurement, Bi-Directional Current and Power Monitor with I2C Compatible Interface, PW0016A	Texas Instruments	INA260AIPWR

6 Revision History

NOTE: Page numbers for previous revisions may differ from page numbers in the current version.

Changes from Revision A (March 2023) to Revision B (July 2023) Page

- Changed title of document to *INA260EVM-PDK Rev A Model User's Guide and Software Tutorial* 1
-

Changes from Revision * (November 2016) to Revision A (March 2023) Page

- Changed user guide title for INA260EVM-PDK (Rev A) hardware support..... 1
 - Changed all instances of legacy terminology to controller and target where I²C is mentioned..... 18
-

STANDARD TERMS FOR EVALUATION MODULES

1. *Delivery:* TI delivers TI evaluation boards, kits, or modules, including any accompanying demonstration software, components, and/or documentation which may be provided together or separately (collectively, an "EVM" or "EVMs") to the User ("User") in accordance with the terms set forth herein. User's acceptance of the EVM is expressly subject to the following terms.
 - 1.1 EVMs are intended solely for product or software developers for use in a research and development setting to facilitate feasibility evaluation, experimentation, or scientific analysis of TI semiconductors products. EVMs have no direct function and are not finished products. EVMs shall not be directly or indirectly assembled as a part or subassembly in any finished product. For clarification, any software or software tools provided with the EVM ("Software") shall not be subject to the terms and conditions set forth herein but rather shall be subject to the applicable terms that accompany such Software
 - 1.2 EVMs are not intended for consumer or household use. EVMs may not be sold, sublicensed, leased, rented, loaned, assigned, or otherwise distributed for commercial purposes by Users, in whole or in part, or used in any finished product or production system.
2. *Limited Warranty and Related Remedies/Disclaimers:*
 - 2.1 These terms do not apply to Software. The warranty, if any, for Software is covered in the applicable Software License Agreement.
 - 2.2 TI warrants that the TI EVM will conform to TI's published specifications for ninety (90) days after the date TI delivers such EVM to User. Notwithstanding the foregoing, TI shall not be liable for a nonconforming EVM if (a) the nonconformity was caused by neglect, misuse or mistreatment by an entity other than TI, including improper installation or testing, or for any EVMs that have been altered or modified in any way by an entity other than TI, (b) the nonconformity resulted from User's design, specifications or instructions for such EVMs or improper system design, or (c) User has not paid on time. Testing and other quality control techniques are used to the extent TI deems necessary. TI does not test all parameters of each EVM. User's claims against TI under this Section 2 are void if User fails to notify TI of any apparent defects in the EVMs within ten (10) business days after delivery, or of any hidden defects with ten (10) business days after the defect has been detected.
 - 2.3 TI's sole liability shall be at its option to repair or replace EVMs that fail to conform to the warranty set forth above, or credit User's account for such EVM. TI's liability under this warranty shall be limited to EVMs that are returned during the warranty period to the address designated by TI and that are determined by TI not to conform to such warranty. If TI elects to repair or replace such EVM, TI shall have a reasonable time to repair such EVM or provide replacements. Repaired EVMs shall be warranted for the remainder of the original warranty period. Replaced EVMs shall be warranted for a new full ninety (90) day warranty period.

WARNING

Evaluation Kits are intended solely for use by technically qualified, professional electronics experts who are familiar with the dangers and application risks associated with handling electrical mechanical components, systems, and subsystems.

User shall operate the Evaluation Kit within TI's recommended guidelines and any applicable legal or environmental requirements as well as reasonable and customary safeguards. Failure to set up and/or operate the Evaluation Kit within TI's recommended guidelines may result in personal injury or death or property damage. Proper set up entails following TI's instructions for electrical ratings of interface circuits such as input, output and electrical loads.

NOTE:

EXPOSURE TO ELECTROSTATIC DISCHARGE (ESD) MAY CAUSE DEGRADATION OR FAILURE OF THE EVALUATION KIT; TI RECOMMENDS STORAGE OF THE EVALUATION KIT IN A PROTECTIVE ESD BAG.

3 Regulatory Notices:

3.1 United States

3.1.1 Notice applicable to EVMs not FCC-Approved:

FCC NOTICE: This kit is designed to allow product developers to evaluate electronic components, circuitry, or software associated with the kit to determine whether to incorporate such items in a finished product and software developers to write software applications for use with the end product. This kit is not a finished product and when assembled may not be resold or otherwise marketed unless all required FCC equipment authorizations are first obtained. Operation is subject to the condition that this product not cause harmful interference to licensed radio stations and that this product accept harmful interference. Unless the assembled kit is designed to operate under part 15, part 18 or part 95 of this chapter, the operator of the kit must operate under the authority of an FCC license holder or must secure an experimental authorization under part 5 of this chapter.

3.1.2 For EVMs annotated as FCC – FEDERAL COMMUNICATIONS COMMISSION Part 15 Compliant:

CAUTION

This device complies with part 15 of the FCC Rules. Operation is subject to the following two conditions: (1) This device may not cause harmful interference, and (2) this device must accept any interference received, including interference that may cause undesired operation.

Changes or modifications not expressly approved by the party responsible for compliance could void the user's authority to operate the equipment.

FCC Interference Statement for Class A EVM devices

NOTE: This equipment has been tested and found to comply with the limits for a Class A digital device, pursuant to part 15 of the FCC Rules. These limits are designed to provide reasonable protection against harmful interference when the equipment is operated in a commercial environment. This equipment generates, uses, and can radiate radio frequency energy and, if not installed and used in accordance with the instruction manual, may cause harmful interference to radio communications. Operation of this equipment in a residential area is likely to cause harmful interference in which case the user will be required to correct the interference at his own expense.

FCC Interference Statement for Class B EVM devices

NOTE: This equipment has been tested and found to comply with the limits for a Class B digital device, pursuant to part 15 of the FCC Rules. These limits are designed to provide reasonable protection against harmful interference in a residential installation. This equipment generates, uses and can radiate radio frequency energy and, if not installed and used in accordance with the instructions, may cause harmful interference to radio communications. However, there is no guarantee that interference will not occur in a particular installation. If this equipment does cause harmful interference to radio or television reception, which can be determined by turning the equipment off and on, the user is encouraged to try to correct the interference by one or more of the following measures:

- Reorient or relocate the receiving antenna.
- Increase the separation between the equipment and receiver.
- Connect the equipment into an outlet on a circuit different from that to which the receiver is connected.
- Consult the dealer or an experienced radio/TV technician for help.

3.2 Canada

3.2.1 For EVMs issued with an Industry Canada Certificate of Conformance to RSS-210 or RSS-247

Concerning EVMs Including Radio Transmitters:

This device complies with Industry Canada license-exempt RSSs. Operation is subject to the following two conditions:

(1) this device may not cause interference, and (2) this device must accept any interference, including interference that may cause undesired operation of the device.

Concernant les EVMs avec appareils radio:

Le présent appareil est conforme aux CNR d'Industrie Canada applicables aux appareils radio exempts de licence. L'exploitation est autorisée aux deux conditions suivantes: (1) l'appareil ne doit pas produire de brouillage, et (2) l'utilisateur de l'appareil doit accepter tout brouillage radioélectrique subi, même si le brouillage est susceptible d'en compromettre le fonctionnement.

Concerning EVMs Including Detachable Antennas:

Under Industry Canada regulations, this radio transmitter may only operate using an antenna of a type and maximum (or lesser) gain approved for the transmitter by Industry Canada. To reduce potential radio interference to other users, the antenna type and its gain should be so chosen that the equivalent isotropically radiated power (e.i.r.p.) is not more than that necessary for successful communication. This radio transmitter has been approved by Industry Canada to operate with the antenna types listed in the user guide with the maximum permissible gain and required antenna impedance for each antenna type indicated. Antenna types not included in this list, having a gain greater than the maximum gain indicated for that type, are strictly prohibited for use with this device.

Concernant les EVMs avec antennes détachables

Conformément à la réglementation d'Industrie Canada, le présent émetteur radio peut fonctionner avec une antenne d'un type et d'un gain maximal (ou inférieur) approuvé pour l'émetteur par Industrie Canada. Dans le but de réduire les risques de brouillage radioélectrique à l'intention des autres utilisateurs, il faut choisir le type d'antenne et son gain de sorte que la puissance isotrope rayonnée équivalente (p.i.r.e.) ne dépasse pas l'intensité nécessaire à l'établissement d'une communication satisfaisante. Le présent émetteur radio a été approuvé par Industrie Canada pour fonctionner avec les types d'antenne énumérés dans le manuel d'usage et ayant un gain admissible maximal et l'impédance requise pour chaque type d'antenne. Les types d'antenne non inclus dans cette liste, ou dont le gain est supérieur au gain maximal indiqué, sont strictement interdits pour l'exploitation de l'émetteur.

3.3 Japan

3.3.1 *Notice for EVMs delivered in Japan:* Please see http://www.tij.co.jp/lstds/ti_ja/general/eStore/notice_01.page 日本国内に輸入される評価用キット、ボードについては、次のところをご覧ください。

<https://www.ti.com/ja-jp/legal/notice-for-evaluation-kits-delivered-in-japan.html>

3.3.2 *Notice for Users of EVMs Considered "Radio Frequency Products" in Japan:* EVMs entering Japan may not be certified by TI as conforming to Technical Regulations of Radio Law of Japan.

If User uses EVMs in Japan, not certified to Technical Regulations of Radio Law of Japan, User is required to follow the instructions set forth by Radio Law of Japan, which includes, but is not limited to, the instructions below with respect to EVMs (which for the avoidance of doubt are stated strictly for convenience and should be verified by User):

1. Use EVMs in a shielded room or any other test facility as defined in the notification #173 issued by Ministry of Internal Affairs and Communications on March 28, 2006, based on Sub-section 1.1 of Article 6 of the Ministry's Rule for Enforcement of Radio Law of Japan,
2. Use EVMs only after User obtains the license of Test Radio Station as provided in Radio Law of Japan with respect to EVMs, or
3. Use of EVMs only after User obtains the Technical Regulations Conformity Certification as provided in Radio Law of Japan with respect to EVMs. Also, do not transfer EVMs, unless User gives the same notice above to the transferee. Please note that if User does not follow the instructions above, User will be subject to penalties of Radio Law of Japan.

【無線電波を送信する製品の開発キットをお使いになる際の注意事項】 開発キットの中には技術基準適合証明を受けていないものがあります。技術適合証明を受けていないものご使用に際しては、電波法遵守のため、以下のいずれかの措置を取っていただく必要がありますのでご注意ください。

1. 電波法施行規則第6条第1項第1号に基づく平成18年3月28日総務省告示第173号で定められた電波暗室等の試験設備でご使用いただく。
2. 実験局の免許を取得後ご使用いただく。
3. 技術基準適合証明を取得後ご使用いただく。

なお、本製品は、上記の「ご使用にあたっての注意」を譲渡先、移転先に通知しない限り、譲渡、移転できないものとします。

上記を遵守頂けない場合は、電波法の罰則が適用される可能性があることをご留意ください。日本テキサス・イ

ンスツルメンツ株式会社

東京都新宿区西新宿 6 丁目 2 4 番 1 号

西新宿三井ビル

3.3.3 *Notice for EVMs for Power Line Communication:* Please see http://www.tij.co.jp/lstds/ti_ja/general/eStore/notice_02.page

電力線搬送波通信についての開発キットをお使いになる際の注意事項については、次のところをご覧ください。 <https://www.ti.com/ja-jp/legal/notice-for-evaluation-kits-for-power-line-communication.html>

3.4 European Union

3.4.1 *For EVMs subject to EU Directive 2014/30/EU (Electromagnetic Compatibility Directive):*

This is a class A product intended for use in environments other than domestic environments that are connected to a low-voltage power-supply network that supplies buildings used for domestic purposes. In a domestic environment this product may cause radio interference in which case the user may be required to take adequate measures.

-
- 4 *EVM Use Restrictions and Warnings:*
 - 4.1 EVMS ARE NOT FOR USE IN FUNCTIONAL SAFETY AND/OR SAFETY CRITICAL EVALUATIONS, INCLUDING BUT NOT LIMITED TO EVALUATIONS OF LIFE SUPPORT APPLICATIONS.
 - 4.2 User must read and apply the user guide and other available documentation provided by TI regarding the EVM prior to handling or using the EVM, including without limitation any warning or restriction notices. The notices contain important safety information related to, for example, temperatures and voltages.
 - 4.3 *Safety-Related Warnings and Restrictions:*
 - 4.3.1 User shall operate the EVM within TI's recommended specifications and environmental considerations stated in the user guide, other available documentation provided by TI, and any other applicable requirements and employ reasonable and customary safeguards. Exceeding the specified performance ratings and specifications (including but not limited to input and output voltage, current, power, and environmental ranges) for the EVM may cause personal injury or death, or property damage. If there are questions concerning performance ratings and specifications, User should contact a TI field representative prior to connecting interface electronics including input power and intended loads. Any loads applied outside of the specified output range may also result in unintended and/or inaccurate operation and/or possible permanent damage to the EVM and/or interface electronics. Please consult the EVM user guide prior to connecting any load to the EVM output. If there is uncertainty as to the load specification, please contact a TI field representative. During normal operation, even with the inputs and outputs kept within the specified allowable ranges, some circuit components may have elevated case temperatures. These components include but are not limited to linear regulators, switching transistors, pass transistors, current sense resistors, and heat sinks, which can be identified using the information in the associated documentation. When working with the EVM, please be aware that the EVM may become very warm.
 - 4.3.2 EVMs are intended solely for use by technically qualified, professional electronics experts who are familiar with the dangers and application risks associated with handling electrical mechanical components, systems, and subsystems. User assumes all responsibility and liability for proper and safe handling and use of the EVM by User or its employees, affiliates, contractors or designees. User assumes all responsibility and liability to ensure that any interfaces (electronic and/or mechanical) between the EVM and any human body are designed with suitable isolation and means to safely limit accessible leakage currents to minimize the risk of electrical shock hazard. User assumes all responsibility and liability for any improper or unsafe handling or use of the EVM by User or its employees, affiliates, contractors or designees.
 - 4.4 User assumes all responsibility and liability to determine whether the EVM is subject to any applicable international, federal, state, or local laws and regulations related to User's handling and use of the EVM and, if applicable, User assumes all responsibility and liability for compliance in all respects with such laws and regulations. User assumes all responsibility and liability for proper disposal and recycling of the EVM consistent with all applicable international, federal, state, and local requirements.
 5. *Accuracy of Information:* To the extent TI provides information on the availability and function of EVMs, TI attempts to be as accurate as possible. However, TI does not warrant the accuracy of EVM descriptions, EVM availability or other information on its websites as accurate, complete, reliable, current, or error-free.
 6. *Disclaimers:*
 - 6.1 EXCEPT AS SET FORTH ABOVE, EVMS AND ANY MATERIALS PROVIDED WITH THE EVM (INCLUDING, BUT NOT LIMITED TO, REFERENCE DESIGNS AND THE DESIGN OF THE EVM ITSELF) ARE PROVIDED "AS IS" AND "WITH ALL FAULTS." TI DISCLAIMS ALL OTHER WARRANTIES, EXPRESS OR IMPLIED, REGARDING SUCH ITEMS, INCLUDING BUT NOT LIMITED TO ANY EPIDEMIC FAILURE WARRANTY OR IMPLIED WARRANTIES OF MERCHANTABILITY OR FITNESS FOR A PARTICULAR PURPOSE OR NON-INFRINGEMENT OF ANY THIRD PARTY PATENTS, COPYRIGHTS, TRADE SECRETS OR OTHER INTELLECTUAL PROPERTY RIGHTS.
 - 6.2 EXCEPT FOR THE LIMITED RIGHT TO USE THE EVM SET FORTH HEREIN, NOTHING IN THESE TERMS SHALL BE CONSTRUED AS GRANTING OR CONFERRING ANY RIGHTS BY LICENSE, PATENT, OR ANY OTHER INDUSTRIAL OR INTELLECTUAL PROPERTY RIGHT OF TI, ITS SUPPLIERS/LICENSORS OR ANY OTHER THIRD PARTY, TO USE THE EVM IN ANY FINISHED END-USER OR READY-TO-USE FINAL PRODUCT, OR FOR ANY INVENTION, DISCOVERY OR IMPROVEMENT, REGARDLESS OF WHEN MADE, CONCEIVED OR ACQUIRED.
 7. *USER'S INDEMNITY OBLIGATIONS AND REPRESENTATIONS.* USER WILL DEFEND, INDEMNIFY AND HOLD TI, ITS LICENSORS AND THEIR REPRESENTATIVES HARMLESS FROM AND AGAINST ANY AND ALL CLAIMS, DAMAGES, LOSSES, EXPENSES, COSTS AND LIABILITIES (COLLECTIVELY, "CLAIMS") ARISING OUT OF OR IN CONNECTION WITH ANY HANDLING OR USE OF THE EVM THAT IS NOT IN ACCORDANCE WITH THESE TERMS. THIS OBLIGATION SHALL APPLY WHETHER CLAIMS ARISE UNDER STATUTE, REGULATION, OR THE LAW OF TORT, CONTRACT OR ANY OTHER LEGAL THEORY, AND EVEN IF THE EVM FAILS TO PERFORM AS DESCRIBED OR EXPECTED.
-

8. *Limitations on Damages and Liability:*

8.1 *General Limitations.* IN NO EVENT SHALL TI BE LIABLE FOR ANY SPECIAL, COLLATERAL, INDIRECT, PUNITIVE, INCIDENTAL, CONSEQUENTIAL, OR EXEMPLARY DAMAGES IN CONNECTION WITH OR ARISING OUT OF THESE TERMS OR THE USE OF THE EVMS , REGARDLESS OF WHETHER TI HAS BEEN ADVISED OF THE POSSIBILITY OF SUCH DAMAGES. EXCLUDED DAMAGES INCLUDE, BUT ARE NOT LIMITED TO, COST OF REMOVAL OR REINSTALLATION, ANCILLARY COSTS TO THE PROCUREMENT OF SUBSTITUTE GOODS OR SERVICES, RETESTING, OUTSIDE COMPUTER TIME, LABOR COSTS, LOSS OF GOODWILL, LOSS OF PROFITS, LOSS OF SAVINGS, LOSS OF USE, LOSS OF DATA, OR BUSINESS INTERRUPTION. NO CLAIM, SUIT OR ACTION SHALL BE BROUGHT AGAINST TI MORE THAN TWELVE (12) MONTHS AFTER THE EVENT THAT GAVE RISE TO THE CAUSE OF ACTION HAS OCCURRED.

8.2 *Specific Limitations.* IN NO EVENT SHALL TI'S AGGREGATE LIABILITY FROM ANY USE OF AN EVM PROVIDED HEREUNDER, INCLUDING FROM ANY WARRANTY, INDEMNITY OR OTHER OBLIGATION ARISING OUT OF OR IN CONNECTION WITH THESE TERMS, , EXCEED THE TOTAL AMOUNT PAID TO TI BY USER FOR THE PARTICULAR EVM(S) AT ISSUE DURING THE PRIOR TWELVE (12) MONTHS WITH RESPECT TO WHICH LOSSES OR DAMAGES ARE CLAIMED. THE EXISTENCE OF MORE THAN ONE CLAIM SHALL NOT ENLARGE OR EXTEND THIS LIMIT.

9. *Return Policy.* Except as otherwise provided, TI does not offer any refunds, returns, or exchanges. Furthermore, no return of EVM(s) will be accepted if the package has been opened and no return of the EVM(s) will be accepted if they are damaged or otherwise not in a resalable condition. If User feels it has been incorrectly charged for the EVM(s) it ordered or that delivery violates the applicable order, User should contact TI. All refunds will be made in full within thirty (30) working days from the return of the components(s), excluding any postage or packaging costs.

10. *Governing Law:* These terms and conditions shall be governed by and interpreted in accordance with the laws of the State of Texas, without reference to conflict-of-laws principles. User agrees that non-exclusive jurisdiction for any dispute arising out of or relating to these terms and conditions lies within courts located in the State of Texas and consents to venue in Dallas County, Texas. Notwithstanding the foregoing, any judgment may be enforced in any United States or foreign court, and TI may seek injunctive relief in any United States or foreign court.

Mailing Address: Texas Instruments, Post Office Box 655303, Dallas, Texas 75265
Copyright © 2023, Texas Instruments Incorporated

IMPORTANT NOTICE AND DISCLAIMER

TI PROVIDES TECHNICAL AND RELIABILITY DATA (INCLUDING DATA SHEETS), DESIGN RESOURCES (INCLUDING REFERENCE DESIGNS), APPLICATION OR OTHER DESIGN ADVICE, WEB TOOLS, SAFETY INFORMATION, AND OTHER RESOURCES "AS IS" AND WITH ALL FAULTS, AND DISCLAIMS ALL WARRANTIES, EXPRESS AND IMPLIED, INCLUDING WITHOUT LIMITATION ANY IMPLIED WARRANTIES OF MERCHANTABILITY, FITNESS FOR A PARTICULAR PURPOSE OR NON-INFRINGEMENT OF THIRD PARTY INTELLECTUAL PROPERTY RIGHTS.

These resources are intended for skilled developers designing with TI products. You are solely responsible for (1) selecting the appropriate TI products for your application, (2) designing, validating and testing your application, and (3) ensuring your application meets applicable standards, and any other safety, security, regulatory or other requirements.

These resources are subject to change without notice. TI grants you permission to use these resources only for development of an application that uses the TI products described in the resource. Other reproduction and display of these resources is prohibited. No license is granted to any other TI intellectual property right or to any third party intellectual property right. TI disclaims responsibility for, and you will fully indemnify TI and its representatives against, any claims, damages, costs, losses, and liabilities arising out of your use of these resources.

TI's products are provided subject to [TI's Terms of Sale](#) or other applicable terms available either on [ti.com](https://www.ti.com) or provided in conjunction with such TI products. TI's provision of these resources does not expand or otherwise alter TI's applicable warranties or warranty disclaimers for TI products.

TI objects to and rejects any additional or different terms you may have proposed.

Mailing Address: Texas Instruments, Post Office Box 655303, Dallas, Texas 75265
Copyright © 2023, Texas Instruments Incorporated

Looking for pricing, stock, or lifecycle information?

Click below to explore more details on WIN SOURCE:

 [View INA260EVM](#) on WIN SOURCE

 [Texas Instruments](#) Information

Optimize Your Supply Chain with WIN SOURCE Solutions

-  Global Sourcing Solution
-  Obsolete Management
-  Cost Control Management
-  Shortage Management
-  Alternative Solution
-  Excess Inventory Management