

Motor Drivers for Printers

Three-phase Brushless Motor Pre-drivers for Paper Feed



BD6761FS, BD6762FV

No.10016EAT01

●Description

This product is the motor predriver for high-side/low-side N-channel MOS-FET drive, which has the built-in booster (step-up) circuit. BD6761FS uses the drive type controlled by the servo signal input from outside and BD6762FV incorporates a servo circuit (Speed discriminator + PLL servo).

●Features

- 1) Predriver for high-side/low-side N-channel MOS-FET
- 2) Built-in booster (step-up) circuit
- 3) Built-in FG and hysteresis amplifiers
- 4) Built-in current limit circuit
- 5) Built-in thermal shutdown circuit
- 6) Built-in forward/reverse rotation switching circuit (BD6761FS, BD6762FV)
- 7) Built-in short brake circuit (BD6761FS, BD6762FV)
- 8) Built-in low voltage protection circuit (BD6761FS, BD6762FV)
- 9) Built-in speed lock detection circuit (BD6762FV)
- 10) Built-in motor lock protection circuit (BD6762FV)
- 11) Built-in start-stop circuit (BD6762FV)
- 12) Built-in servo circuit (Speed discriminator + PLL) (BD6762FV)
- 13) Built-in frequency multiplication circuit (BD6762FV)
- 14) 180°, direct PWM drive (BD6761FS)
- 15) 120°, slope switchable direct PWM drive (BD6762FV)

●Applications

Main motor for paper feed of the laser beam printer and PPC

●Absolute Maximum Ratings (Ta=25°C)

Parameter	Symbol	Ratings		Unit
		BD6761FS	BD6762FV	
Applied voltage	VCC	36	36	V
Applied voltage	VG	36	36	V
Pin input voltage	Vin	VREG	VREG	V
Power dissipation	Pd	950 ^(※1)	1100 ^(※2)	mW
Operating temperature range	TOPR	-35 ~ +75	-25 ~ +75	°C
Storage temperature range	TSTG	-40 ~ +150	-40 ~ +150	°C
Junction temperature	Tjmax	150	150	°C

※1 Reduced by 7.6 mW/°C over 25°C, when mounted on a glass epoxy board (70 mm × 70 mm × 1.6 mm).

※2 Reduced by 8.8 mW/°C over 25°C, when mounted on a glass epoxy board (70 mm × 70 mm × 1.6 mm).

●Line up Matrix

	BD6761FS	BD6762FV	Unit
Power supply voltage (VCC)	16~28	16~28	V
Drive type	180°	120° / 120° slope	—
Servo	No	Yes	—

● Electrical Characteristics

BD6761FS (Unless otherwise specified, Ta=25°C, VCC=24.0V)

Parameter	Symbol	Limits			Unit	Conditions
		Min.	Typ.	Max.		
Overall						
Circuit current	ICC	10	15	20	mA	
VREG voltage	VREG	5.5	6	6.5	V	IVREG=-1mA
Hall amp						
Input bias current	IHA	—	0.7	3.0	μA	
In-phase input voltage range	VHAR	1.5	—	4.1	V	
Input level	VINH	30	—	250	mVpp	Single-phase Hall amplitude
PWM						
High CFE voltage	VHPCFE	3.0	3.5	4.0	V	
Low CFE voltage	VLPCFE	2.1	2.5	2.9	V	
CFE oscillating frequency	FCFE	12	15	18	kHz	RFE=50kΩ, CFE=1000pF
PWM on duty offset	DPWM	-1.5	0	1.5	%	
Torque amplifier						
High CPOUT input current	ICPOUTH	—	0	1	μA	
Low CPOUT input current	ICPOUTL	-1	0	—	μA	
Current limit						
Current detection voltage 1	VCL1	0.391	0.435	0.479	V	For current sense amplifier
Current detection voltage 2	VCL2	0.432	0.480	0.528	V	For current limit comparator
VCL2-VCL1	ΔVCL	40	45	50	mV	
FG Amp						
Input bias current	IBFG	-1	—	1	μA	
Input offset voltage	VBFG	-10	—	10	mV	
High output voltage	VHFG	4.5	5.0	VREG	V	IHFGOUT=-0.75mA
Low output voltage	VLFG	—	1.0	1.5	V	ILFGOUT=2mA
Low FGS output voltage	VLFGS	—	0.1	0.3	V	ILFGSOUT=3mA
Open loop gain	GVFG	45	54	—	dB	f=3kHz
Bias voltage	VBIASFG	2.7	3.0	3.3	V	
Hysteresis width	VHYS	100	180	250	mV	
F/R						
High input current	IFRL	30	60	90	μA	F/R=6V
Low input current	IFRH	-10	0	10	μA	F/R=0V
High input level	VIHFR	2.2	—	VREG	V	Reverse rotation
Low input level	VILFR	0	—	0.8	V	Forward rotation
ACC and DEC						
High ACC input current	IACCH	30	60	90	μA	ACC=6V
Low ACC input current	IACCL	-10	0	10	μA	ACC=0V
High DEC input current	IDECH	30	60	90	μA	DEC=6V
Low DEC input current	IDECL	-10	0	10	μA	DEC=0V
Accelerating current	ISS	-260	-200	-140	μA	RCP=13.5kΩ, ACC=L
Decelerating current	ISO	140	200	260	μA	RCP=13.5kΩ, DEC=L
High ACC input level	VIHACC	2.2	—	VREG	V	
Low ACC input level	VILACC	0	—	0.8	V	
High DEC input level	VIHDEC	2.2	—	VREG	V	
Low DEC input level	VILDEC	0	—	0.8	V	
High-side output						
High-side voltage	VHG	Vcc+5	Vcc+6	Vcc+7	V	
Pull-down resistor	RHD	70	100	130	kΩ	
Low-side output						
Low-side voltage	VLG	9.5	10.5	11.5	V	
Pull-down resistor	RLD	70	100	130	kΩ	
Booster						
Boost voltage	VG	Vcc+5	Vcc+6	Vcc+7	V	
CP1 oscillating frequency	FCP1	35	62.5	85	kHz	

BD6762FV (Unless otherwise specified, Ta=25°C, VCC=24V)

Parameter	Symbol	Limits			Unit	Conditions
		Min.	Typ.	Max.		
Overall						
Circuit current 1	ICCS	5.1	7.6	10.2	mA	ST/SP=OPEN
Circuit current 2	ICC	10	17	25	mA	ST/SP=GND
VREG voltage	VREG	4.5	5	5.5	V	IVREG=-1mA
Low voltage protection level	VUVON	9.5	11.5	13.5	V	
Low voltage protection hysteresis level	VUVHYS	0.4	0.5	0.6	V	
Hall amp						
Input bias current	IBH	—	1	3	μA	
In-phase input voltage range	VHAR	0	—	3	V	
Input level	VINH	50	—	—	mVp-p	
PWM						
High CFE voltage	VCFEH	2.6	2.9	3.2	V	
Low CFE voltage	VCFEL	1.2	1.4	1.6	V	
CFE oscillating frequency	FCFE	13	16	19	kHz	RFE=20K, CFE=1000pF
REF voltage	VRFE	0.75	0.95	1.15	V	
FG amp						
Input bias current	IFGM	-1	—	1	μA	
Input offset voltage	VFGOF	-10	—	10	mV	
High output voltage	VFGOH	3.5	4.0	—	V	I=-0.5mA
Low output voltage	VFGOL	—	1.0	1.5	V	I=0.5mA
Low FGS output voltage	VFGSL	—	0.1	0.3	V	I=2mA
Open loop gain	GFG	45	54	—	dB	f=3kHz
Bias voltage	VBFG	2.25	2.50	2.75	V	
Hysteresis width	VFGHYS	100	180	250	mV	
Integration amp						
Di clamp voltage 1	VDI1	1.5	2.1	2.7	V	INTIN=0.1mA
Di clamp voltage 2	VDI2	0.5	0.7	0.9	V	INTOUT=0.1mA
Bias voltage	VBERR	2.25	2.50	2.75	V	INTIN=INTOUT
Speed discriminator						
High output voltage	VDOH	VREG-0.3	VREG-0.1	—	V	I=-0.1mA
Low output voltage	VDOL	—	0.1	0.3	V	I=0.1mA
PLL						
High output voltage	VPOH	VREG-0.45	VREG-0.15	—	V	I=-0.1mA
Low output voltage	VPOL	—	0.15	0.45	V	I=0.1mA
Lock detection						
Low output voltage	VLDL	—	0.15	0.3	V	I=2mA
Lock protection						
CLK cycle for protection circuit	TLP	13	20	27	msec	LP=0.1μF
VCO						
CLK input frequency range	FCLK	0.2	—	2.5	kHz	Designed value (VCO alone)
High-level CLK input voltage	VCKH	2.2	—	VREG	V	
Low-level CLK input voltage	VCKL	0	—	0.8	V	
High-level CLK input current	ICKH	-10	—	10	μA	
Low-level CLK input current	ICKL	-140	-100	-60	μA	

BD6762FV (Unless otherwise specified, Ta=25°C, VCC=24 V)

Parameter	Symbol	Limits			Unit	Conditions
		Min.	Typ.	Max.		
Start/Stop						
High-level ST/SP input voltage	VSTH	2.2	—	VREG	V	STOP
Low-level ST/SP input voltage	VSTL	0	—	0.8	V	START
High-level ST/SP input current	ISTH	-10	0	10	μA	
Low-level ST/SP input current	ISTL	-70	-50	-30	μA	
Forward rotation/Reverse rotation						
High-level FR input voltage	VFRH	2.2	—	VREG	V	Reverse rotation
Low-level FR input voltage	VFRL	0	—	0.8	V	Forward rotation
High-level FR input current	IFRH	-10	0	10	μA	
Low-level FR input current	IFRL	-70	-50	-30	μA	
120°/Slope switching						
High-level 120/slope input voltage	VANH	2.2	—	VREG	V	120°
Low-level 120/slope input voltage	VANL	0	—	0.8	V	120° slope
High-level 120/slope input current	IANH	-10	0	10	μA	
Low-level 120/slope input current	IANL	-70	-50	-30	μA	
Short brake						
High-level SB input voltage	VSBH	2.2	—	VREG	V	Short brake operation
Low-level SB input voltage	VSBL	0	—	0.8	V	Short brake clear
High-level SB input current	ISBH	-10	0	10	μA	
Low-level SB input current	ISBL	-70	-50	-30	μA	
Current limit						
Current detection voltage	VCL	0.23	0.26	0.29	V	
Booster						
CP1 oscillating frequency	FCP1	75	125	175	kHz	
VG step-up voltage	VG	VCC+5.7	VCC+6.7	VCC+7.7	V	
High-side output						
High output voltage 1	VHHG1	VCC+5.8	VCC+6.8	VCC+7.8	V	VG=31V
High output voltage 2	VHHG2	VCC+3.8	VCC+4.8	VCC+5.8	V	Io=-1mA
Low output voltage 1	VHLG1	—	0.1	0.3	V	
Low output voltage 2	VHLG2	—	0.5	1.0	V	Io=5mA
Clamp voltage	VHCL	10	11	12	V	
Low-side output						
High output voltage 1	VLHG1	9.8	10.8	11.8	V	
High output voltage 2	VLHG2	9.0	10.0	11.0	V	Io=-5mA
Low output voltage 1	VLLG1	—	0.1	0.3	V	
Low output voltage 2	VLLG2	—	0.3	0.5	V	Io=5mA

●Reference Data

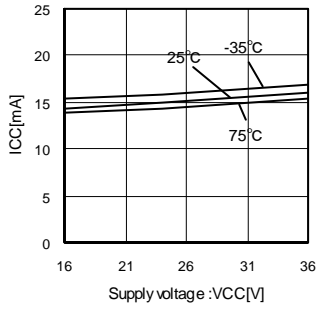

Fig.1 Circuit current (BD6761FS)

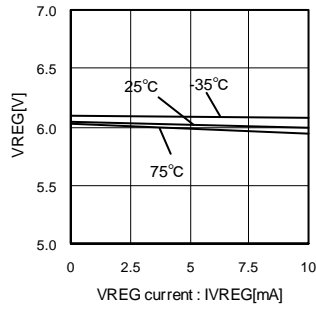

Fig. 2 VREG Voltage (BD6761FS)

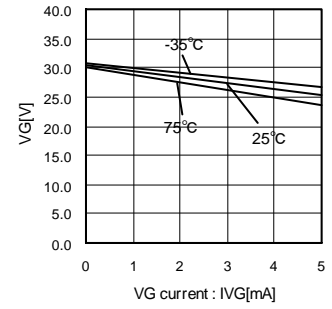

Fig. 3 VG Voltage (BD6761FS)

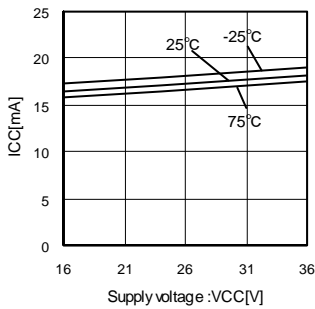

Fig.4 Circuit current (BD6762FV)

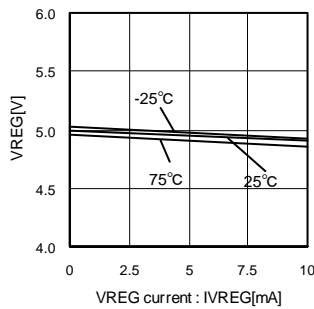

Fig.5 VREG Voltage (BD6762FV)

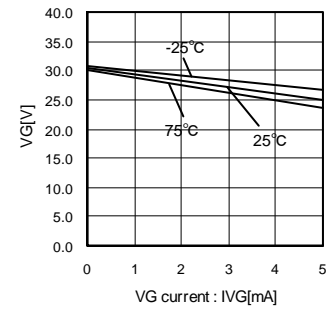

Fig.6 VG Voltage (BD6762FV)

●Power Dissipation Reduction

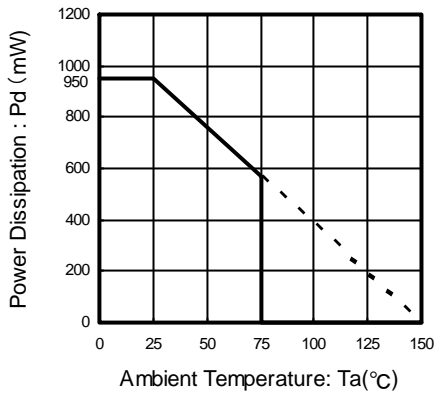

Fig.7 BD6761FS Power Dissipation Reduction
Reduced by 7.6 mW/°C over 25°C, when mounted on a glass epoxy board (70 mm × 70 mm × 1.6 mm).

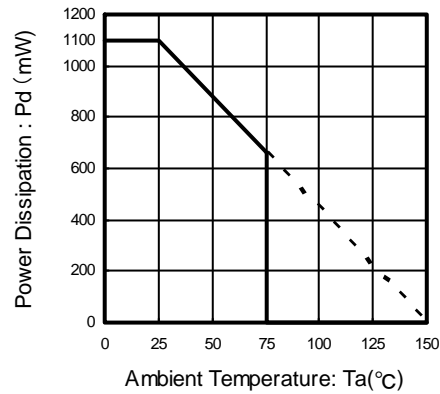

Fig.8 BD6762FV Power Dissipation Reduction
Reduced by 8.8 mW/°C over 25°C, when mounted on a glass epoxy board (70 mm × 70 mm × 1.6 mm)°Cで軽減。

●Block Diagram, Application Circuit Diagram, and Pin Function

1)BD6761FS

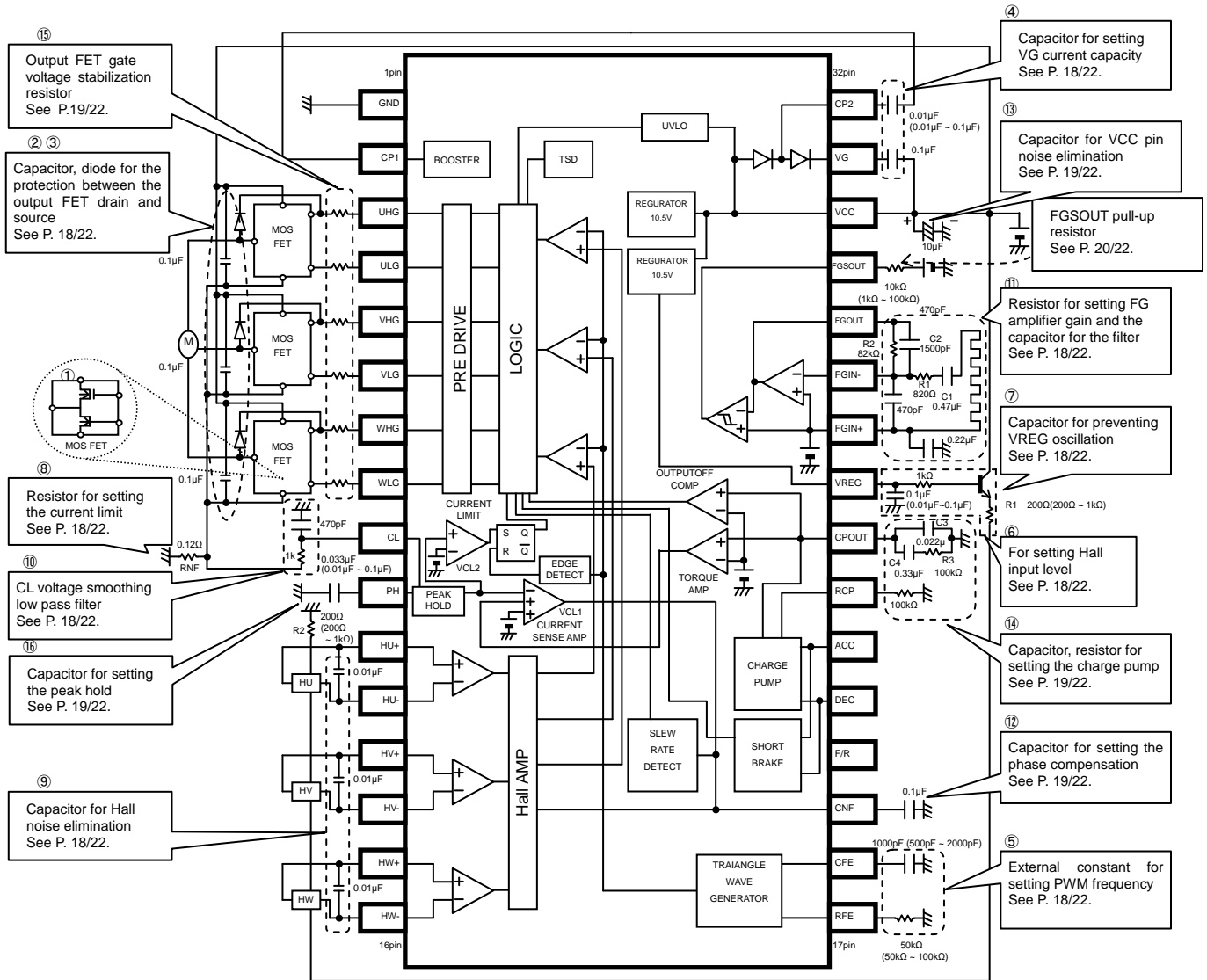

Fig.9 BD6761FS Block Diagram

BD6761FS pin Function

No.	Pin name	Function	No.	Pin name	Function
1	GND	GND pin	17	RFE	CFE current control pin
2	CP1	CP1 pin	18	CFE	PWM frequency control pin
3	UHG	U-phase high-side FET gate pin	19	CNF	Phase compensation pin
4	ULG	U-phase low-side FET gate pin	20	F/R	Forward/reverse rotation switching pin
5	VHG	V-phase high-side FET gate pin	21	DEC	Deceleration signal input pin
6	VLG	V-phase low-side FET gate pin	22	ACC	Acceleration signal input pin
7	WHG	W-phase high-side FET gate pin	23	RCP	CPOUT current control pin
8	WLG	W-phase low-side FET gate pin	24	CPOUT	Charge pump output / Torque control signal input pin
9	CL	Motor current detection pin	25	VREG	VREG pin
10	PH	Peak hold pin	26	FGIN+	FG input + pin
11	HU+	Hall signal input pin	27	FGIN-	FG input - pin
12	HU-	Hall signal input pin	28	FGOUT	FG output pin
13	HV+	Hall signal input pin	29	FGSOUT	FGS output pin
14	HV-	Hall signal input pin	30	VCC	VCC pin
15	HW+	Hall signal input pin	31	VG	Boost pin
16	HW-	Hall signal input pin	32	CP2	CP2 pin

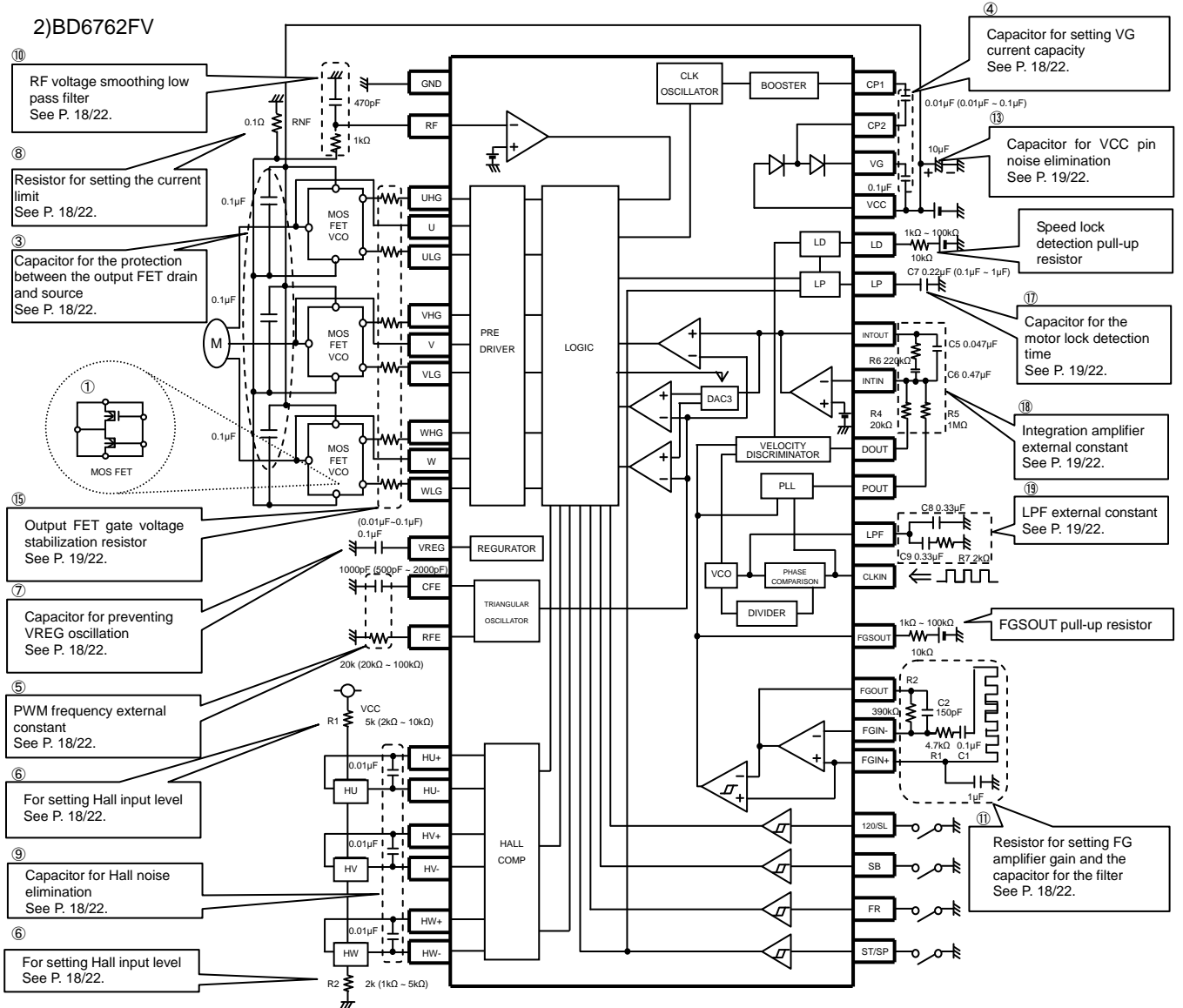

Fig.10 BD6762FV Block Diagram

BD6762FV pin Function

No.	Pin name	Function	No.	Pin name	Function
1	GND	GND pin	21	ST/SP	Start/Stop pin
2	RF	Motor current detection pin	22	FR	Forward/reverse rotation switching pin
3	UHG	U-phase high-side FET gate pin	23	SB	Short brake pin
4	U	Protection pin for U-phase high-side FET GS breakdown voltage	24	120/SL	120°/slope switching pin
5	ULG	U-phase low-side FET gate pin	25	FGIN+	FG amplifier input + pin
6	VHG	V-phase high-side FET gate pin	26	FGIN-	FG amplifier input - pin
7	V	Protection pin for V-phase high-side FET GS breakdown voltage	27	FGOUT	FG amplifier output pin
8	VLG	V-phase low-side FET gate pin	28	FGSOUT	FGS output pin
9	WHG	W-phase high-side FET gate pin	29	CLKIN	Reference CLK input pin
10	W	Protection pin for W-phase high side FET GS breakdown voltage	30	LPF	VCO system loop filter connection pin
11	WLG	W-phase low-side FET gate pin	31	POUT	PLL output pin
12	VREG	Internal power supply 5 V output pin	32	DOUT	Speed discriminator output pin
13	CFE	PWM frequency control pin	33	INTIN	Integration amplifier input pin
14	RFE	CEF charge/discharge current control pin	34	INTOUT	Integration amplifier output pin
15	HU+	Hall signal input pin	35	LP	Motor lock protection time setting pin
16	HU-	Hall signal input pin	36	LD	Motor rotation number lock detection pin
17	HV+	Hall signal input pin	37	VCC	VCC pin
18	HV-	Hall signal input pin	38	VG	Step-up voltage output pin
19	HW+	Hall signal input pin	39	CP2	Capacitor connection pin (to CP1)
20	HW-	Hall signal input pin	40	CP1	Capacitor connection pin (to CP2)

● I/O Logic

1) BD6761FS

Forward rotation (F/R=Low)

Pin No.	Input conditions			Output state					
	15 HU+	17 HV+	19 HW+	3 UHG	5 VHG	7 WHG	4 ULG	6 VLG	8 WLG
Condition 1	L	M	H	H	H	L	L	L	H
Condition 2	L	H	H	H	PWM	L	L	PWM	H
Condition 3	L	H	M	H	L	L	L	H	H
Condition 4	L	H	L	H	L	PWM	L	H	PWM
Condition 5	M	H	L	H	L	H	L	H	L
Condition 6	H	H	L	PWM	L	H	PWM	H	L
Condition 7	H	M	L	L	L	H	H	H	L
Condition 8	H	L	L	L	PWM	H	H	PWM	L
Condition 9	H	L	M	L	H	H	H	L	L
Condition 10	H	L	H	L	H	PWM	H	L	PWM
Condition 11	M	L	H	L	H	L	H	L	H
Condition 12	L	L	H	PWM	H	L	PWM	L	H

Reverse rotation (F/R=High)

Pin No.	Input conditions			Output state					
	15 HU+	17 HV+	19 HW+	3 UHG	5 VHG	7 WHG	4 ULG	6 VLG	8 WLG
Condition 1	L	M	H	L	L	H	H	H	L
Condition 2	L	H	H	L	PWM	H	H	PWM	L
Condition 3	L	H	M	L	H	H	H	L	L
Condition 4	L	H	L	L	H	PWM	H	L	PWM
Condition 5	M	H	L	L	H	L	H	L	H
Condition 6	H	H	L	PWM	H	L	PWM	L	H
Condition 7	H	M	L	H	H	L	L	L	H
Condition 8	H	L	L	H	PWM	L	L	PWM	H
Condition 9	H	L	M	H	L	L	L	H	H
Condition 10	H	L	H	H	L	PWM	L	H	PWM
Condition 11	M	L	H	H	L	H	L	H	L
Condition 12	L	L	H	PWM	L	H	PWM	H	L

<Input conditions>

Hall input voltage

H: 3.05V

M: 3.0V

L: 2.95V

<Output criteria>

High-side FET gate voltage

 $L \leq 1V, VG-1V \leq H$

Low-side FET gate voltage

 $L \leq 1V, 9V \leq H$

ACC, DEC

Pin No.	Input conditions		Output state	
	21 DEC	22 ACC	24 CPOUT	Short brake
Condition 1	H	H	OPEN	OFF
Condition 2	H	L	H	OFF
Condition 3	L	H	L	OFF
Condition 4	L	L	L	ON

<Input conditions>

ACC, DEC input conditions

H : 2.2V

L : 0.8V

<Output criteria>

○CPOUT

RCP=13.5kΩ, CPOUT=3V

High: Current outflow more than 140μA from CPOUT pin

Low: Current inflow more than 140μA to CPOUT pin

OPEN: CPOUT pin current $-10\mu\text{A} \leq I_{\text{CPOUT}} \leq 10\mu\text{A}$

○Short brake function

On state

High-side FET gate voltage $\leq 1\text{V}$ Low-side FET gate voltage $\geq 9\text{V}$

2)BD6762FV

Forward rotation (F/R=Low), 120° (120/SL=High)

Pin No.	Input conditions			Output state								
	15	17	19	High-side gate			Low-side gate			Output		
	HU+	HV+	HW+	3	6	9	5	8	11	4	7	10
				UHG	VHG	WHG	ULG	VLG	WLG	U	V	W
Condition 1	L	L	H	L	H	L	L	L	H	M	H	L
Condition 2	H	L	H	L	H	L	H	L	L	L	H	M
Condition 3	H	L	L	L	L	H	H	L	L	L	M	H
Condition 4	H	H	L	L	L	H	L	H	L	M	L	H
Condition 5	L	H	L	H	L	L	L	H	L	H	L	M
Condition 6	L	H	H	H	L	L	L	L	H	H	M	L

Reverse rotation (F/R=High), 120° (120/SL=High)

Pin No.	Input condition			Output state								
	15	17	19	High-side gate			Low-side gate			Output		
	HU+	HV+	HW+	3	6	9	5	8	11	4	7	10
				UHG	VHG	WHG	ULG	VLG	WLG	U	V	W
Condition 1	L	L	H	L	L	H	L	H	L	M	L	H
Condition 2	H	L	H	H	L	L	L	H	L	H	L	M
Condition 3	H	L	L	H	L	L	L	L	H	H	M	L
Condition 4	H	H	L	L	H	L	L	L	H	M	H	L
Condition 5	L	H	L	L	H	L	H	L	L	L	H	M
Condition 6	L	H	H	L	L	H	H	L	L	L	M	H

ST/SP	Mode
OPEN or High	Standby
L	Operating mode

<Input condition>

Hall input voltage H : 2.0V
 M : 1.5V
 L : 1.0V
 HU-, HV-, HW- : M

<Output criteria>

High-side FET gate voltage : $L \leq \text{output (U, V, W)} + 1V, VG - 1V \leq H$
 Low-side FET gate voltage : $L \leq 1V, 9V \leq H$

● Timing Chart

1) BD6761FS

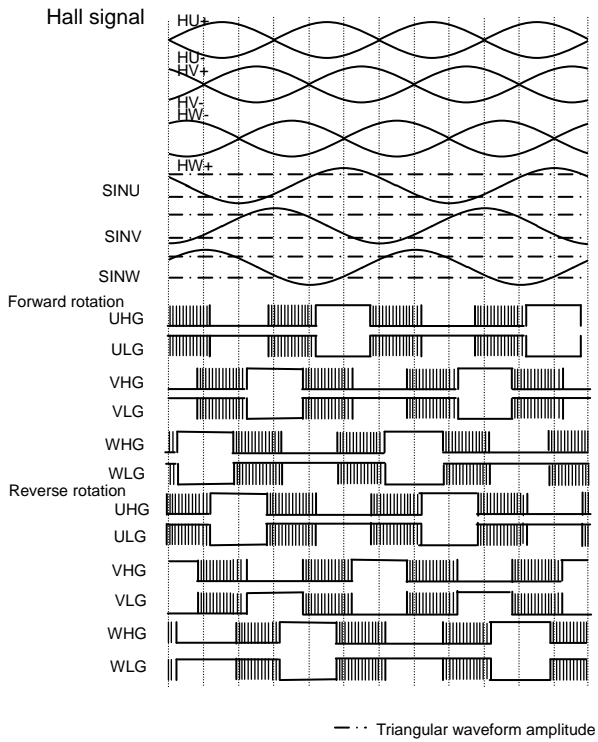

Fig.11 BD6761FS I/O Timing Chart

SINU, SINV, and SINW are the internal IC signals synthesized by the Hall amplifier.

2) BD6762FV

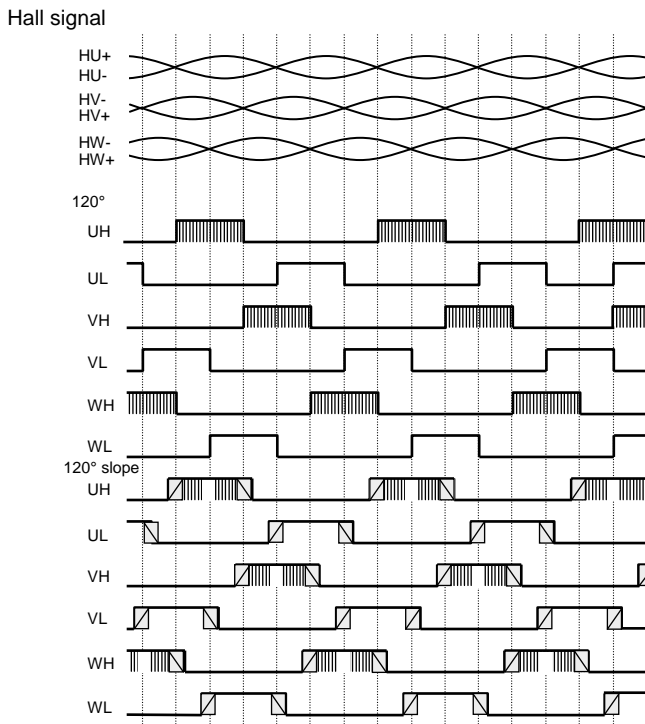
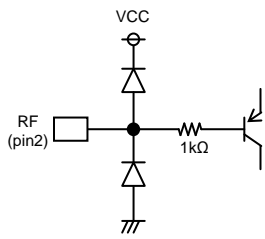

Fig.12 BD6762FV I/O Timing Chart

2)BD6762FV

ORF pin



OUHG, VH, WH, U, V, W pins

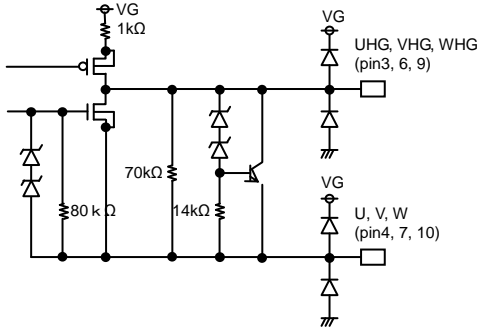

OULG, VLG, WLG pins

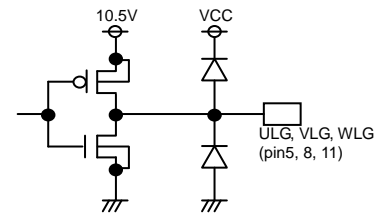

OCFE pin

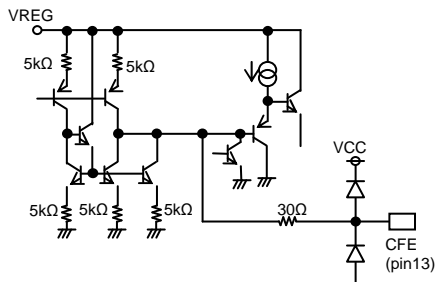

ORFE pin

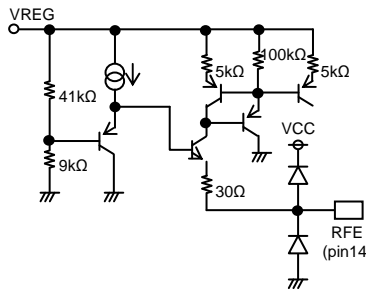

OST/SP, FR, SB, 120/SL

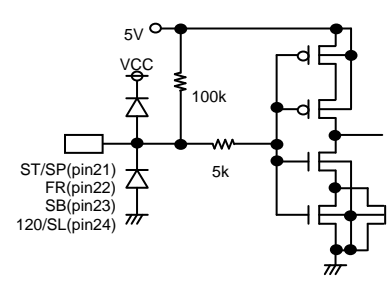

HU+, HV+, HW+, HU-, HV-, HW- pins

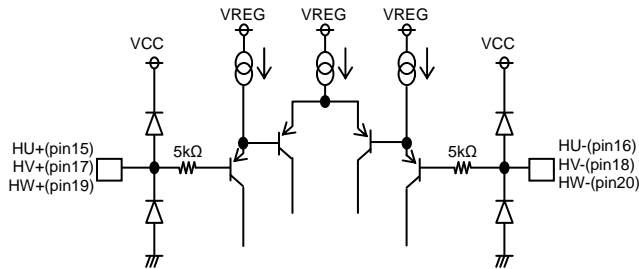

OFGIN+, FGIN- pins

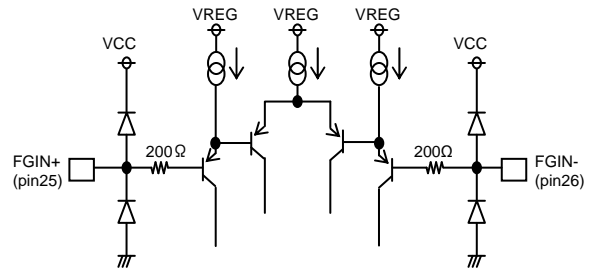

OCLKIN

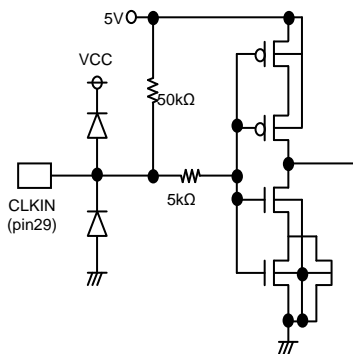

OFGIN+, FGOUT pins

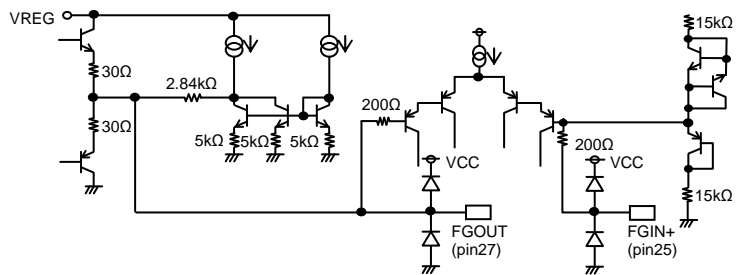

FGSOUT pin

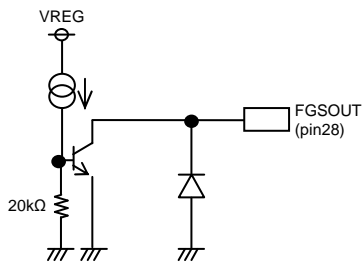

OLPF pin

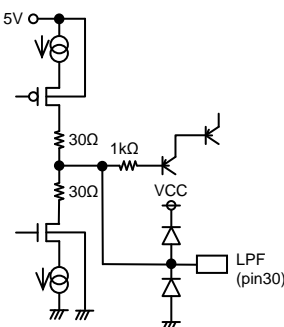

OPOUT, DOUT pins

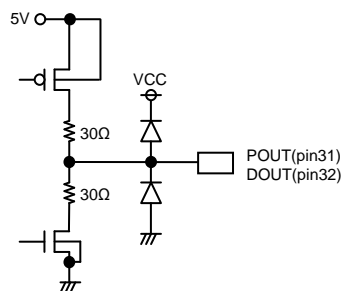

○ INTIN pin

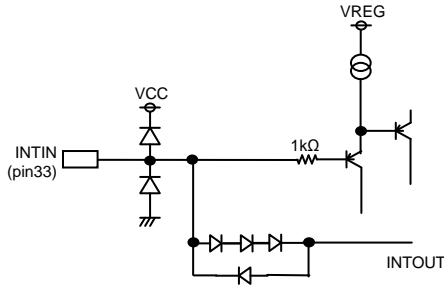

○ INTOUT pin

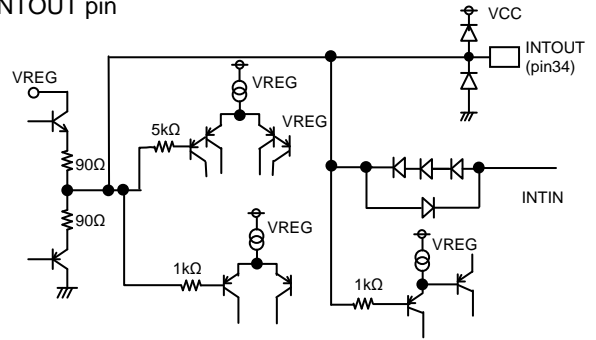

○ OLP pin

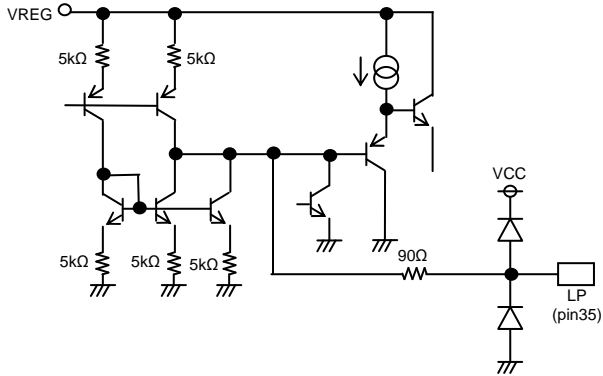

○ OLD pin

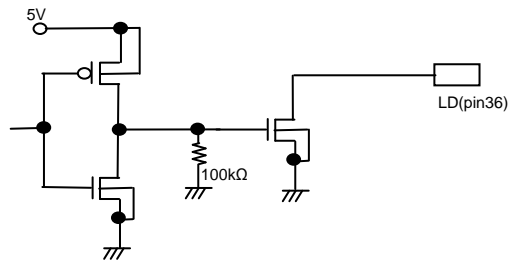

○ VG, CP2, CP1 pins

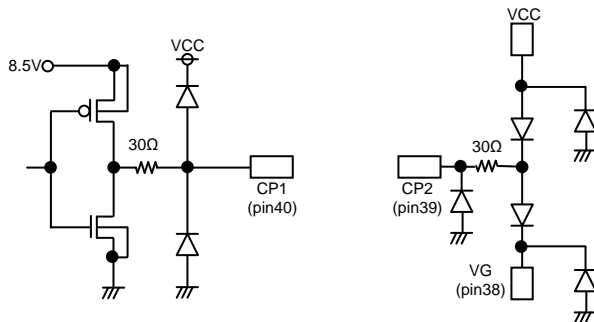

● IC Operation

1) Hall input and output

For the hall input signal, the wave is shaped by the hall amplifier to generate the drive signal.

This drive signal is amplified in the predriver block and the gate voltage is output for N-channel MOS FET.

2) PWM operation

PWM oscillating frequency is determined by the triangular waveform frequency which is decided by the external constant. This triangular waveform voltage and the listed voltage in the following chart are compared to perform PWM drive.

	Rfe, RFE	Cfe, CFE	Cfe, CFE pin charge/discharge current I	Frequency (Typ.)	Comparison voltage
BD6761FS	50kΩ	1000pF	1.6V/R	16.5kHz	Drive signal shaped by the hall amplifier
BD6762FV	20kΩ	1000pF	VRFE/R	16kHz	Integration amplifier output pin voltage

3) Booster circuit (step-up circuit) (common)

BD6761FS (Frequency = 62.5 kHz) and BD6762FV (Frequency = 125 kHz) generate the triangular waveform when the internal oscillator generates free-run oscillation and the rectangular waveform is generated at CP1. When a capacitor is connected between CP1 and CP2, and VG and GND, the step-up voltage is generated at VG pin. In this case, set VCC so that VG does not exceed the absolute maximum ratings (36 V).

	Triangular waveform oscillating frequency	Charge pump voltage (VG pin voltage)
BD6761FS	62.5 kHz	VCC+6V
BD6762FV	125 kHz	VCC+6.7V

4) FG amplifier (common)

Set the FG amplifier gain so that the FGOUT pin is within the range of high and low output voltage and the amplitude is higher than the hysteresis width (250 mV: max) of the HYS amplifier.

FGSOUT pin uses an open collector format. Use in the condition as it is pulled up to the power supply with the resistor. At this time, pay attention so that the voltage higher than 36 V is not applied to the FGSOUT pin.

5) ACC, DEC circuits (BD6761FS)

When a resistor is connected to the RCP pin and the low voltage is input to the ACC pin, the current flows out from the CPOUT pin. When the low signal is input to the DEC pin, the current flows in to the CPOUT pin. Furthermore, when the ACC pin and DEC pin both set to low, the current flows in to the CPOUT pin. This current can be converted to the voltage by connecting a filter between the CPOUT and GND pins.

The voltage generated at the CPOUT pin controls the PWM's on-duty and maintains the constant motor rotation by inputting the controlled signal to ACC and DEC pins.

6) Current limit operation

When the CL voltage (BD6761FS) and RF voltage (BD6762FV) become the current limit voltage, the current limit circuit operates and works to limit PWM on_dutty. It also turns off the current limit circuit (current limit clear) at the peak of PWM triangular waveform and makes the current flow again. Output current Iomax at this time are shown in the table.

	Current limit current
BA6761FS	Iomax=0.48/RNF [A]
BA6762FV	Iomax=0.26/RNF [A]

7) Output simultaneous on prevention circuit (BD6761FS, BD6762FV)

When the low-side gate voltage becomes high while the high-side gate voltage is low, or when the high-side gate voltage becomes high while the low-side gate voltage is low, the simultaneous on prevention time is provided with $t=3.2\ \mu\text{s}$ (TYP value). When the input capacity of external FET is C and the gate connection resistor is R, set R to satisfy the following equation so that the simultaneous on prevention time as mentioned above is not exceeded.

$$C \leq \frac{1.8\mu}{10 \times (24 + R)}$$

Check that the simultaneous on is not made in the actual operation and then set C and R.

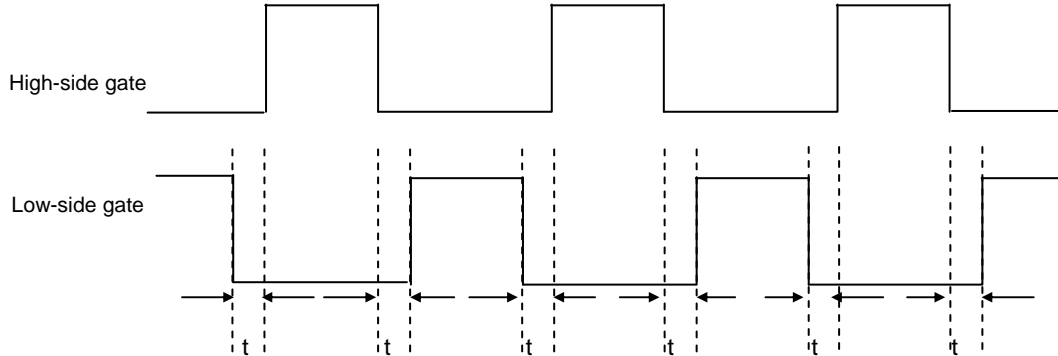

Fig.13 High/Low-side Simultaneous On Prevention Timing Chart

8) Short brake (BD6761FS and BD6762FV)

BD6761FS operates the short brake action with the ACC and DEC pins set to low, and BD6762FV does with the SB pin set to OPEN or high. At the time of short brake, the high-side gate is turned off and the low-side is turned on. At the time of short brake operating, the current flows to the output FET, which is decided by the motor's counter electromotive voltage and coil impedance. Since this current flows via path which does not run through the overcurrent protection (current limit) detection resistor, the overcurrent protection does not operate as IC operating. Therefore, the current more than the overcurrent protection set current may flow to the output FET, pay attention so that it does not exceed the output FET rating.

9) Forward/reverse rotation circuit (BD6761FS and BD6762FV)

Forward /reverse rotation of motor can be switched according to the FR pin input conditions. Logics of the hall input and output conditions according to the FR pin input conditions are shown in the I/O conditions table (P.10). If the FR pin is switched during the motor rotation, since the simultaneous on prevention circuit in IC operates, the feed through current does not flow. However, since the motor current flows in the direction to the power source due to the electromotive force, the voltage may be raised if the power source does not have the power supply voltage absorption ability. Examine the capacitor characteristics between the power supply and ground sufficiently and then pay attention so that the power supply voltage and step-up voltage do not exceed the absolute maximum ratings. When the physical measures are taken such as increasing the capacitor value which is connected between the power supply and ground, check the characteristics enough prior to use.

10) Start/stop circuit (BD6762FV)

When the ST/SP pin is in the state of OPEN or high, IC becomes standby. In the case of standby, some circuits operation are turned off to reduce the current consumption.

When the ST/SP pin is in the state of low, IC becomes operating.

11) Low voltage protection circuit (BD6761FS and BD6762FV)

This IC builds in the low voltage protection circuit. When VCC becomes lower than 11.5 V (Typ.), the high-side and low-side gates are both turned off to make the coil turn off. Protection off voltage is 12.0 V (Typ.) and hysteresis width is 0.5 V (Typ.). Since the motor locking protection detection circuit operates in BD6762FV during the low voltage protection operation, if the low voltage protection operating time becomes longer than the motor locking protection detection time, the operation moves to the motor locking protection operation after the low voltage protection operation.

12) Built-in 120° slope PWM logic (BD6762FV)

It is possible to perform 120° drive by setting 120/SL pin to OPEN or making high. 120° slope drive is possible by setting the 120/SL pin to OPEN or making high. Low noise design is realized by reducing the electromagnetic sound generated at the time of phase switching by means of gradually changing the output PWM on-duty during 120° slope energization. However, at the time of startup or the hall input frequency is lower than about 3 Hz (Typ. value), it becomes 120° drive. When the hall input frequency is more than about 3 Hz (Typ. value) and the rise of hall U-phase is detected 7 times, it switches to the 120° slope drive.

13) Servo circuit (BD6762FV)

- Frequency multiplication circuit (Dividing period) (BD6762FV)

This IC builds in the frequency multiplication circuit.

Servo circuit is composed of the feedback loop as shown in the diagram and flows in/out the current ($22\ \mu\text{A}$: Typ.) to the LPF pin (30 pin) by detecting the phase difference between the CLKIN pin (29 pin) and the frequency dividing unit output FCOMP. The phase difference signal output to the LPF pin (30 pin) is smoothed by the filter which is connected at the IC external of the LPF pin (30 pin) and this voltage is input to the VCO (Voltage control oscillation circuit) to decide the frequency for the internal signal FVCO. Since the dividing ratio of this frequency dividing unit is set to 1024, the relation of

$$\text{FVCO}[\text{Hz}] = 1024 \cdot \text{FCOMP}[\text{Hz}]$$

can be obtained, and the FCOMP and CLKIN have the same frequency according to the feedback loop as shown in the following diagram, therefore the multiplied frequency of 1024 times of FCOMP or CLKIN is acquired as the FVCO frequency.

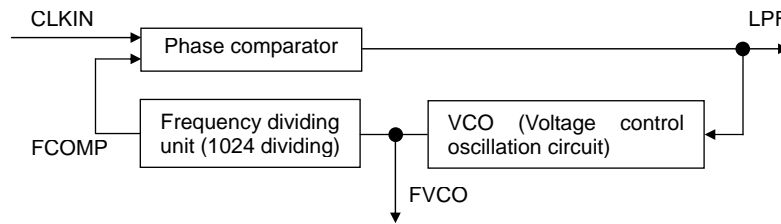

- Speed discriminator (BD6762FV)

The FGSOUT signal (28 pin) which detects the motor rotation speed and the reference clock in IC are compared and the acceleration/deceleration signal is output to the DOUT pin (32 pin). Reference clock is the signal (FVCO) that the CLKIN signal (29 pin) is multiplied by 1024. When the FG period is short to the reference clock period, it is determined that the motor revolution speed is too fast and the difference from the reference clock period is output to the DOUT pin as the deceleration command. When the FG period is long, the difference is output as an accelerating command.

- PLL (BD6762FV)

Phases of the FGSOUT (28 pin) signal which detected the motor revolution speed and the CLKIN (29 pin) input from the external are compared, and if the FG phase leads to CLKIN (28 pin), the difference is output as the deceleration command. If the FG phase lags, the difference is output as the acceleration command.

- Integration amplifier (BD6762FV)

Speed error of the reference clock which is obtained in the speed discriminator block and the FG signal, and the phase difference signal of the CLKIN acquired in PLL block and the FG are integrated together and smoothed to become the DC voltage. This smoothed signal determines the PWM on-duty.

14) Speed lock detection circuit (BD6762FV)

When the motor speed is within $\pm 6.25\%$ range to the CLKIN signal (29 pin), L is output to the LD pin (36 pin) output.

Since the LD pin (36 pin) has the open/drain output format, use as it is pulled up to the power supply with the resistor ($100\text{k}\Omega$). At this time, pay attention so that the voltage more than 36 V is not applied to the LD pin.

15) Motor locking protection (BD6762FV)

Motor locking protection circuit judges the motor is in the locking condition when the motor speed is not in the lock range (preset value: $\pm 6.25\%$) and the motor locking detection time T_{LP} elapsed, the high-side and low-side output gates are both turned off. Motor locking protection can be cleared by making the condition Low after setting the ST/SP pin or the SB pin to OPEN or making high. Motor locking detection time T_{LP} is determined by the capacitor C7 which is connected to the LP pin and the count number CLP (preset value: 96) of the internal counter.

$$T_{LP} = 2 \times 10^5 \times C7 \times \text{CLP} [\text{S}]$$

● Selecting application components

Design method	Design example
① Output FET This IC is the predriver for high-side and low-side N-channel MOS FET drive. Select the FET with the required current capacity to drive the motor.	Recommended FET RDS035L03 (A)
② Diodes (BD67861FS) Diodes are required to protect between the gate and source of output FET.	Recommended diode 1SS355 Insert the diode in the direction from high-side FET source to the gate side (in the forward direction).
③ Protection capacitor between the output FET drain and source Check the operation so that the voltage between the output FET drain and source does not exceed the absolute maximum ratings due to the fluctuation of VCC at the time of PWM driving and then set the value.	A value of 0.01 μ F to 0.1 μ F is recommended. A value of 0.1 μ F is appropriate for the capacitance. Insert the capacitor between the output FET drain and source. (Position at the close point to FET as much as possible.)
④ VB current capacitance capacitor Current capacity from VG changes according to the capacitance to be connected. However, if the capacitance is too large, the following action is delayed when VCC starts up, and the magnitude relation becomes VCC > VG which should be VCC < VG usually and the large current may flow in internal block circuits and result in damaging the circuits. When VG is directly supplied from the external block without using the internal circuits, disconnect the capacitor between CP1 and CP2, and connect the 20k Ω resistor (for noise reduction) between CP1 and ground to use.	A value of 0.01 μ F is appropriate for the capacitor between CP1 and CP2 (A value of 0.01 μ F 0.1 μ F is recommended.) A value of 0.1 μ F is appropriate for the capacitor between VG and VCC.
⑤ PWM frequency PWM frequency can be adjusted by the capacitance and resistance to connect. When the frequency is high, the heat generation increases due to switching loss. When the frequency is low, it enters audible range. Check the operation with the actual product and determine the constant.	The following constants are appropriate. BD6761FS Cfe=1000pF, Rfe=50k Ω , fo=16.5kHz(TYP.) BD6762FV Cfe=1000pF, Rfe=20k Ω , fo=16.0kHz(TYP.)
⑥ Hall input level The current value to feed to the hall element changes by changing the resistance and the amplitude level of hall element can be adjusted. Amplitude level increases when the resistance value is chosen smaller by considering the noise affect, but pay attention also to the hall input voltage range. BD6761FS (1.5V to 4.1V) and BD6762FV (0V to 3V)	Connect to the transistor base via 1k Ω resistor (base current limit) from the VREG pin. Connect the transistor collector to VCC, the emitter to the hall element via R1. Connect the ground side of hall element to the ground via R2. A value of 200 Ω to 1k Ω is recommended. A value of 200 Ω is appropriate, respectively. When connecting to the VCC side directly with R1, values of R1=5k Ω and R2=2k Ω are appropriate.
⑦ VREG VREG which is the internal voltage output pin drives the circuits in IC. Connect the capacitor to stabilize it.	A value of 0.01 μ F to 0.1 μ F is recommended. A value of 0.1 μ is appropriate.
⑧ Current limit The current flowing to FET can be controlled by setting the resistance value. Determine the constant according to the motor specifications.	Following equation shows the current value. BD6761FS Iomax=0.48/RNF [A] BD6762FV Iomax=0.26/RNF [A]
⑨ Hall input noise Insert capacitors between the hall phases in order to eliminate the hall input noise due to the effect by the pattern routing design.	A value of 0.01 μ F is appropriate for the capacitor to be installed between the hall phases. A value of 0.01 μ F to 0.1 μ F is recommended.
⑩ CL (RF) voltage smoothing low pass filter Smooth the CL (RF) voltage which has PWM noise through the low pass filter.	A value of C = 470pF and R=1k Ω is appropriate for the low pass filter. For the external constant, since the impedance is high, make sure to design the pattern with the shortest circuit route so that the circuit is hard to be affected by noise.
⑪ FG AMP constant setting FG AMP gain: GFG is the ratio of R1 and R2 calculated by the following equation. GFG=20log R2/R1 [dB] Set up the gain so that the FGOUT amplitude is large enough to the hysteresis level of the hysteresis comparator and it cannot be clamped by the high and low output voltages (VFGOH and VFGOL).	R1 and C1 form a high pass filter and R2 and C2 form a low pass filter. Each cut off frequency; fMPF and fLPF is determined by the following equation. fMPF=1/2 π R1C1, fLPF=1/2 π R2C2 Set the value so that the main signal from PG by the motor is not attenuated but the unnecessary noise can be attenuated.

Design method	Design example
<p>⑫ Phase compensation capacitor (BD6761FS) Phase compensation is performed in the output of the CS amplifier. The capacitance value should be selected according to the servo constant, and proper motor operation should be confirmed. When the capacitance is large, the I/O response becomes bad. When it is small, the output becomes easy to oscillate.</p>	<p>A value of 0.001μF to 0.1μF is recommended. A value of 0.001μF is appropriate for BA6680FS. A value of 0.1μF is appropriate for BD6761FS.</p>
<p>⑬ VCC pin Set up the capacitance for the stabilization and noise reduction on the power line.</p>	<p>A value of value 1μF to 10μF is recommended. A value of 10μF is appropriate.</p>
<p>⑭ Charge pump filter (BD6761FS) Filter composed of C3, C4 and R3 smoothes the current pulses output from the CPOUT pin and converts it to DC. This impedance Z is shown by the following equation.</p> $Z = R3 \times \frac{C4}{C3+C4} \times \frac{S+\omega_2}{S \left(1 + \frac{S}{\omega_1} \right)}$ <p>When the pole frequency is set to fP1 and fP2, they are: fP1 = $\omega_1/2\pi = 1/2\pi (C3//C4)R3$ fP2 = $\omega_2/2\pi = 1/2\pi C4R3$</p>	<p>Recommended value C3: 0.01μF to 0.1μF; a value of 0.01μF is appropriate. C4: 0.033μF to 0.33μF; a value of 0.1μF is appropriate. R3 : 30kΩ to 300kΩ; a value of 100kΩ is appropriate.</p>
<p>⑮ Output FET gate voltage stabilization resistor When the noise is generated at the time of external MOSFET on/off due to the rise and fall speed of the IC output, insert the resistor between the IC output and external MOSFET gate.</p>	<p>Establish R so that the simultaneous on prevention time is not exceeded as shown in 7). Output simultaneous on prevention circuit in P.17/24 Operating Explanation. A value of R = 0Ω is appropriate.</p>
<p>⑯ Peak hold setting capacitor (BD6761FS) Charges the peak hold on the voltage at the current detection pin CL.</p>	<p>A value of 0.33μF is appropriate.</p>
<p>⑰ Motor locking detection time setting capacitor (BD6762FV) Motor locking detection time T_{LP} is determined by the capacitor C7 which is connected to the LP pin and the count number CLP (Preset value: 96) of the internal counter. The T_{LP} is shown by the following equation. T_{LP} = $2 \times 10^5 \times C7 \times 96$</p>	<p>A value of 0.22μF is appropriate.</p>
<p>⑱ Integration amplifier constant setting (BD6762FV) Speed discriminator side current value I_D is shown by $I_D = 2.5/R4$ and the PLL side current value I_P is shown by $I_P = 2.5/R5$. Therefore, the current I_{IN} which flows in the integration AMP input pin INTIN is shown by $I_{IN} = I_D + I_P$. The larger the I_{IN} is, the higher the integration amplifier gain becomes. Gains of the speed discriminator and PLL can be set by adjusting R4 and R5. Gain G is shown by the following equation.</p> $G = \frac{R6}{R4 // R5} \times \frac{C6}{C5+C6} \times \frac{S+\omega_2}{S \left(1 + \frac{S}{\omega_1} \right)}$ <p>When the pole frequency is set to fP1 and fP2, they are: fP1 = $\omega_1/2\pi = 1/2\pi (C5//C6) \times R6$ fP2 = $\omega_2/2\pi = 1/2\pi C6R6$</p>	<p>Recommended value R4: 10kΩ to 40kΩ; a value of 20 kΩ is appropriate. R5: 300kΩ to 3MΩ; a value of 1 MΩ is appropriate. R6: 100kΩ to 500kΩ; a value of 220 kΩ is appropriate. C5: 0.01μF to 0.1μF; a value of 0.047μF is appropriate. C6: 0.033μF to 1.0μF; a value of 0.47μF is appropriate.</p>
<p>⑲ LPF external constant (BD6762FV) Filter composed of C8, C9 and R7 smoothes the current pulses output from the LPF pin and converts it to DC. This impedance Z is shown by the following equation.</p> $Z = R7 \times \frac{C9}{C8+C9} \times \frac{S+\omega_2}{S \left(1 + \frac{S}{\omega_1} \right)}$ <p>When the pole frequency is set to fP1 and fP2, they are: fP1 = $\omega_1/2\pi = 1/2\pi (C8//C9)R7$ fP2 = $\omega_2/2\pi = 1/2\pi C9R7$</p>	<p>Recommended value C8: 0.1μF to 0.6μF; a value of 0.33μF is appropriate. C9: 0.1μF to 0.6μF; a value of 0.33μF is appropriate. R7: 0.5kΩ to 10kΩ; a value of 2kΩ is appropriate.</p>

※Setting values in these materials are only for reference. Actual set may change its characteristics due to the boards layout, wiring and components type to use.
Please perform the sufficient verification using the actual product for the field operation.

● Notes for use

- (1) Absolute maximum ratings
This product is subject to a strict quality management regime during its manufacture. Use of the IC in excess of absolute maximum ratings such as the applied voltage or operating temperature range may result in IC damage. Assumptions should not be made regarding the state of the IC (short mode or open mode) when such damage is suffered. A physical safety measure such as a fuse should be implemented when use of the IC in a special mode where the absolute maximum ratings may be exceeded is anticipated.
- (2) Connecting the power supply connector backward
Connecting the power supply connector backwards may result in damage to the IC. For the protection of the IC from reversed connections, provide an appropriate measure, such as the insertion of an external diode each between the power supply and the power supply pin of the IC and between the motor coils.
- (3) Power supply lines
The regenerated current resulting from the back EMF of the motor will return. Therefore, take an appropriate measure, such as the insertion of a capacitor between the power supply and GND. Determine the capacitance in full consideration of all the characteristics of the electrolytic capacitor, because the electrolytic capacitor may lose some capacitance at low temperatures. If the connected power supply does not have sufficient current absorption capacity, regenerative current will cause the voltage on the power supply line to rise, which combined with the product and its peripheral circuitry may exceed the absolute maximum ratings. It is recommended to implement a physical safety measure such as the insertion of a voltage clamp diode between the power supply and GND pins.
- (4) GND potential
Ensure a minimum GND pin potential in all operating conditions.
- (5) Setting of heat
Use a thermal design that allows for a sufficient margin in light of the power dissipation (Pd) in actual operating conditions.
- (6) Pin shorts and mistake fitting
Use caution when orienting and positioning the IC for mounting on printed circuit boards. Improper mounting may result in damage to the IC. Shorts between output pins or between output pins and the power supply and GND pins caused by the presence of a foreign object may result in damage to the IC.
- (7) Actions in strong magnetic field
Use caution when using the IC in the presence of a strong magnetic field as doing so may cause the IC to malfunction.
- (8) ASO
When using the IC, set the output transistor so that it does not exceed absolute maximum ratings or ASO.
- (9) Thermal shutdown circuit (TSD)
This IC incorporates a TSD circuit. If the chip becomes the following temperature, coil output to the motor will be open. The TSD circuit is designed only to shut the IC off to prevent runaway thermal operation. It is not designed to protect the IC or guarantee its operation. Do not continue to use the IC after operating this circuit or use the IC in an environment where the operation of the TSD circuit is assumed.

	TSD on temperature [°C] (Typ.)	Hysteresis temperature [°C] (Typ.)
BD6761FS	175	35
BD6762FV	175	23

- (10) PWM drive
Voltage between the output FET drain and source may exceed the absolute maximum ratings due to the fluctuation of VCC at the time of PWM driving. If there is the threat of this problem, it is recommended to take physical countermeasures for safety such as inserting the capacitor between the VCC pin of FET and the detection resistor pin.
- (11) Testing on application boards
When testing the IC on an application board, connecting a capacitor to a pin with low impedance subjects the IC to stress. Always discharge capacitors after each process or step. Ground the IC during assembly steps as an antistatic measure, and use similar caution when transporting or storing the IC. Always turn the IC's power supply off before connecting it to or removing it from a jig or fixture during the inspection process.

(12) Regarding input pin of the IC

This monolithic IC contains P+ isolation and P substrate layers between adjacent elements in order to keep them isolated.

P/N junctions are formed at the intersection of these P layers with the N layers of other elements to create a variety of parasitic elements.

For example, when a resistor and transistor are connected to pins as shown in Fig. 14,

- the P/N junction functions as a parasitic diode when $GND > (Pin A)$ for the resistor or $GND > (Pin B)$ for the transistor (NPN).
- Similarly, when $GND > (Pin B)$ for the transistor (NPN), the parasitic diode described above combines with the N layer of other adjacent elements to operate as a parasitic NPN transistor.

The formation of parasitic elements as a result of the relationships of the potentials of different pins is an inevitable result of the IC's architecture. The operation of parasitic elements can cause interference with circuit operation as well as IC malfunction and damage. For these reasons, it is necessary to use caution so that the IC is not used in a way that will trigger the operation of parasitic elements, such as by the application of voltages lower than the GND (P substrate) voltage to input pins.

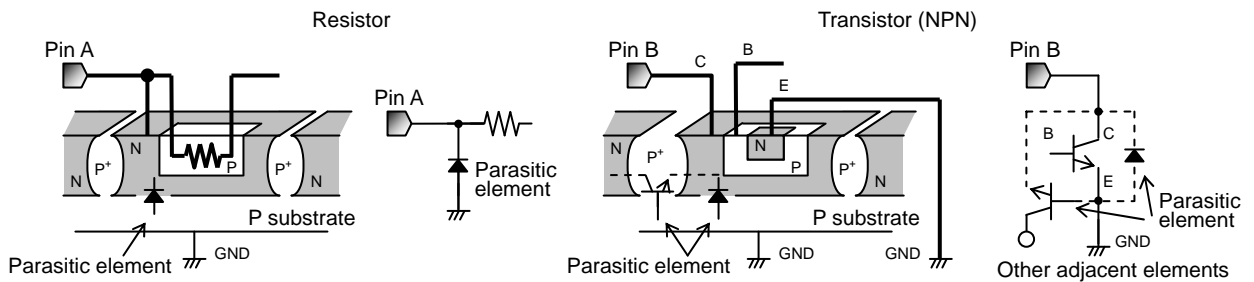

Fig. 14 Mimetic Diagram of Parasitic Element

(13) Ground Circuit Pattern

When using both small signal and large current GND patterns, it is recommended to isolate the two ground patterns, placing a single ground point at the application's reference point so that the pattern wiring resistance and voltage variations caused by large currents do not cause variations in the small signal ground voltage. Be careful not to change the GND wiring pattern of any external parts, either.

● Ordering part number

B	D
---	---

Part No.

6	7	6	1
---	---	---	---

Part No.
6761
6762

F	S
---	---

Package
FS : SSOP-A32
FV : SSOP-B40

E	2
---	---

Packaging and forming specification
E2: Embossed tape and reel

SSOP-A32

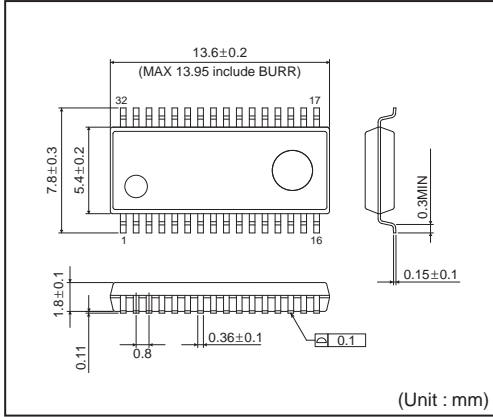

<Tape and Reel information>

Tape	Embossed carrier tape
Quantity	2000pcs
Direction of feed	E2 (The direction is the 1pin of product is at the upper left when you hold reel on the left hand and you pull out the tape on the right hand)

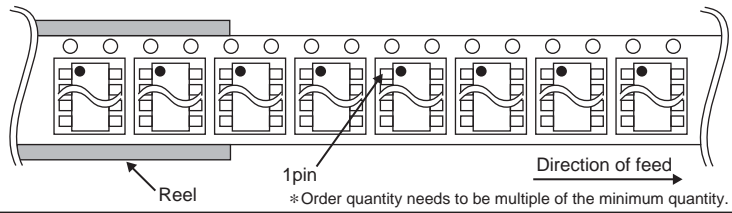

SSOP-B40

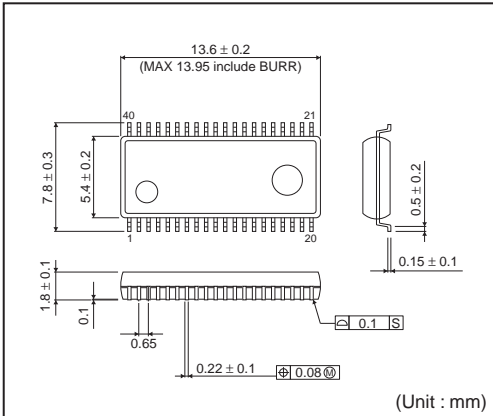

<Tape and Reel information>

Tape	Embossed carrier tape
Quantity	2000pcs
Direction of feed	E2 (The direction is the 1pin of product is at the upper left when you hold reel on the left hand and you pull out the tape on the right hand)

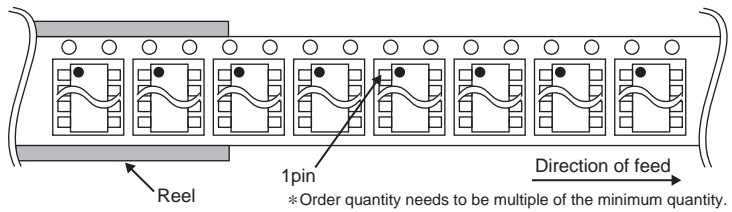

Notice

Precaution on using ROHM Products

- Our Products are designed and manufactured for application in ordinary electronic equipments (such as AV equipment, OA equipment, telecommunication equipment, home electronic appliances, amusement equipment, etc.). If you intend to use our Products in devices requiring extremely high reliability (such as medical equipment ^(Note 1), transport equipment, traffic equipment, aircraft/spacecraft, nuclear power controllers, fuel controllers, car equipment including car accessories, safety devices, etc.) and whose malfunction or failure may cause loss of human life, bodily injury or serious damage to property ("Specific Applications"), please consult with the ROHM sales representative in advance. Unless otherwise agreed in writing by ROHM in advance, ROHM shall not be in any way responsible or liable for any damages, expenses or losses incurred by you or third parties arising from the use of any ROHM's Products for Specific Applications.

(Note1) Medical Equipment Classification of the Specific Applications

JAPAN	USA	EU	CHINA
CLASS III	CLASS III	CLASS II b	CLASS III
CLASS IV		CLASS III	

- ROHM designs and manufactures its Products subject to strict quality control system. However, semiconductor products can fail or malfunction at a certain rate. Please be sure to implement, at your own responsibilities, adequate safety measures including but not limited to fail-safe design against the physical injury, damage to any property, which a failure or malfunction of our Products may cause. The following are examples of safety measures:
 - Installation of protection circuits or other protective devices to improve system safety
 - Installation of redundant circuits to reduce the impact of single or multiple circuit failure
- Our Products are designed and manufactured for use under standard conditions and not under any special or extraordinary environments or conditions, as exemplified below. Accordingly, ROHM shall not be in any way responsible or liable for any damages, expenses or losses arising from the use of any ROHM's Products under any special or extraordinary environments or conditions. If you intend to use our Products under any special or extraordinary environments or conditions (as exemplified below), your independent verification and confirmation of product performance, reliability, etc. prior to use, must be necessary:
 - Use of our Products in any types of liquid, including water, oils, chemicals, and organic solvents
 - Use of our Products outdoors or in places where the Products are exposed to direct sunlight or dust
 - Use of our Products in places where the Products are exposed to sea wind or corrosive gases, including Cl₂, H₂S, NH₃, SO₂, and NO₂
 - Use of our Products in places where the Products are exposed to static electricity or electromagnetic waves
 - Use of our Products in proximity to heat-producing components, plastic cords, or other flammable items
 - Sealing or coating our Products with resin or other coating materials
 - Use of our Products without cleaning residue of flux (even if you use no-clean type fluxes, cleaning residue of flux is recommended); or Washing our Products by using water or water-soluble cleaning agents for cleaning residue after soldering
 - Use of the Products in places subject to dew condensation
- The Products are not subject to radiation-proof design.
- Please verify and confirm characteristics of the final or mounted products in using the Products.
- In particular, if a transient load (a large amount of load applied in a short period of time, such as pulse. is applied, confirmation of performance characteristics after on-board mounting is strongly recommended. Avoid applying power exceeding normal rated power; exceeding the power rating under steady-state loading condition may negatively affect product performance and reliability.
- De-rate Power Dissipation (Pd) depending on Ambient temperature (Ta). When used in sealed area, confirm the actual ambient temperature.
- Confirm that operation temperature is within the specified range described in the product specification.
- ROHM shall not be in any way responsible or liable for failure induced under deviant condition from what is defined in this document.

Precaution for Mounting / Circuit board design

- When a highly active halogenous (chlorine, bromine, etc.) flux is used, the residue of flux may negatively affect product performance and reliability.
- In principle, the reflow soldering method must be used; if flow soldering method is preferred, please consult with the ROHM representative in advance.

For details, please refer to ROHM Mounting specification

Precautions Regarding Application Examples and External Circuits

1. If change is made to the constant of an external circuit, please allow a sufficient margin considering variations of the characteristics of the Products and external components, including transient characteristics, as well as static characteristics.
2. You agree that application notes, reference designs, and associated data and information contained in this document are presented only as guidance for Products use. Therefore, in case you use such information, you are solely responsible for it and you must exercise your own independent verification and judgment in the use of such information contained in this document. ROHM shall not be in any way responsible or liable for any damages, expenses or losses incurred by you or third parties arising from the use of such information.

Precaution for Electrostatic

This Product is electrostatic sensitive product, which may be damaged due to electrostatic discharge. Please take proper caution in your manufacturing process and storage so that voltage exceeding the Products maximum rating will not be applied to Products. Please take special care under dry condition (e.g. Grounding of human body / equipment / solder iron, isolation from charged objects, setting of ionizer, friction prevention and temperature / humidity control).

Precaution for Storage / Transportation

1. Product performance and soldered connections may deteriorate if the Products are stored in the places where:
 - [a] the Products are exposed to sea winds or corrosive gases, including Cl₂, H₂S, NH₃, SO₂, and NO₂
 - [b] the temperature or humidity exceeds those recommended by ROHM
 - [c] the Products are exposed to direct sunshine or condensation
 - [d] the Products are exposed to high Electrostatic
2. Even under ROHM recommended storage condition, solderability of products out of recommended storage time period may be degraded. It is strongly recommended to confirm solderability before using Products of which storage time is exceeding the recommended storage time period.
3. Store / transport cartons in the correct direction, which is indicated on a carton with a symbol. Otherwise bent leads may occur due to excessive stress applied when dropping of a carton.
4. Use Products within the specified time after opening a humidity barrier bag. Baking is required before using Products of which storage time is exceeding the recommended storage time period.

Precaution for Product Label

QR code printed on ROHM Products label is for ROHM's internal use only.

Precaution for Disposition

When disposing Products please dispose them properly using an authorized industry waste company.

Precaution for Foreign Exchange and Foreign Trade act

Since our Products might fall under controlled goods prescribed by the applicable foreign exchange and foreign trade act, please consult with ROHM representative in case of export.

Precaution Regarding Intellectual Property Rights

1. All information and data including but not limited to application example contained in this document is for reference only. ROHM does not warrant that foregoing information or data will not infringe any intellectual property rights or any other rights of any third party regarding such information or data. ROHM shall not be in any way responsible or liable for infringement of any intellectual property rights or other damages arising from use of such information or data.:
2. No license, expressly or implied, is granted hereby under any intellectual property rights or other rights of ROHM or any third parties with respect to the information contained in this document.

Other Precaution

1. This document may not be reprinted or reproduced, in whole or in part, without prior written consent of ROHM.
2. The Products may not be disassembled, converted, modified, reproduced or otherwise changed without prior written consent of ROHM.
3. In no event shall you use in any way whatsoever the Products and the related technical information contained in the Products or this document for any military purposes, including but not limited to, the development of mass-destruction weapons.
4. The proper names of companies or products described in this document are trademarks or registered trademarks of ROHM, its affiliated companies or third parties.

General Precaution

1. Before you use our Products, you are requested to carefully read this document and fully understand its contents. ROHM shall not be in any way responsible or liable for failure, malfunction or accident arising from the use of any ROHM's Products against warning, caution or note contained in this document.
2. All information contained in this document is current as of the issuing date and subject to change without any prior notice. Before purchasing or using ROHM's Products, please confirm the latest information with a ROHM sales representative.
3. The information contained in this document is provided on an "as is" basis and ROHM does not warrant that all information contained in this document is accurate and/or error-free. ROHM shall not be in any way responsible or liable for any damages, expenses or losses incurred by you or third parties resulting from inaccuracy or errors of or concerning such information.

Looking for pricing, stock, or lifecycle information?

Click below to explore more details on WIN SOURCE:

- [⊖ View **BD6762FV-E2** on WIN SOURCE](#)
- [⊖ **Rohm Semiconductor** Information](#)

Optimize Your Supply Chain with WIN SOURCE Solutions

- ✓ Global Sourcing Solution
- ✓ Obsolete Management
- ✓ Cost Control Management
- ✓ Shortage Management
- ✓ Alternative Solution
- ✓ Excess Inventory Management