



**THE DATASHEET OF
IL 3085E**



Low-Cost Isolated RS-485 Transceivers

Functional Diagrams

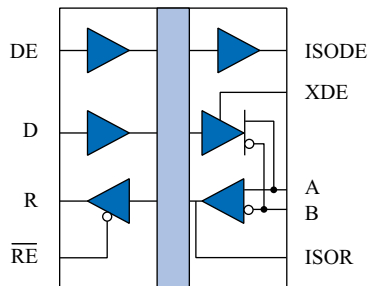

IL3085-1
(QSOP)

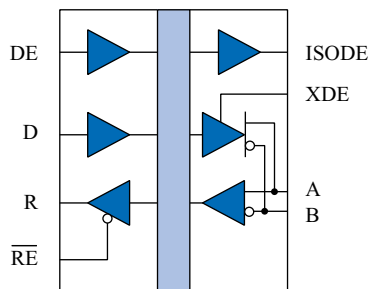

IL3085-3
(narrow-body)

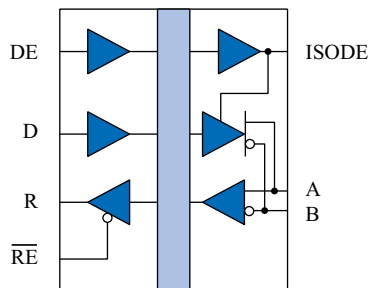

IL3085
(wide-body)

V _{ID} (A-B)	DE	RE	R	D	Mode	Notes
≥ 200 mV	L	L	H	X	Receive	
≤ -200mV	L	L	L	X		
Open	L	L	H	X		A/B failsafe
≥ 1.5 V	H	L	H	H	Drive	R reads back D information
≤ -1.5 V	H	L	L	L		
≥ 1.5 V	H	H	Z	H		R tri-state (no output)
≤ -1.5 V	H	H	Z	L		
X	L	H	Z	X	Disabled	R tri-state; A/B failsafe

Features

- 4 Mbps data rate
- Supports up to 32 nodes
- 3 V to 5 V power supplies
- 50 kV/μs typ.; 30 kV/μs min. common mode transient immunity
- Low quiescent supply current
- 44000 year barrier life
- 7 kV bus ESD protection
- Low EMC footprint
- Thermal shutdown protection
- -40 °C to +85 °C and -40 °C to +125 °C versions
- Meets or exceeds ANSI RS-485 and ISO 8482:1987(E)
- 2500 V_{RMS} isolation voltage per UL 1577
- VDE V 0884-11/IEC 60747-17:2020 certified; UL 1577 recognized
- QSOP, 0.15" SOIC, and 0.3" True 8™ mm 16-pin SOIC packages

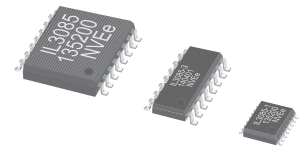

Applications

- Factory automation
- Industrial control networks
- Building environmental controls
- Equipment covered under IEC 61010-1 Edition 3
- 5 kV_{RMS} rated IEC 60601-1 medical applications

Description

The IL3085 is a galvanically isolated, high-speed differential bus transceiver, designed for bidirectional data communication on balanced transmission lines. The device uses NVE's patented* spintronic Giant Magnetoresistance (GMR) technology.

A unique ceramic/polymer composite barrier provides excellent isolation and virtually unlimited barrier life.

The wide-body version provides true 8 mm creepage. Narrow-body and QSOP packages offer unprecedented miniaturization.

The IL3085 delivers at least 1.5 V into a 27 Ω load for excellent data integrity over long cable lengths. The device is compatible with 3.3 V input supplies, allowing interface to standard microcontrollers without additional level shifting.

Current limiting and thermal shutdown features protect against output short circuits and bus contention that may cause excessive power dissipation. Receiver inputs feature a "fail-safe if open" design, ensuring a logic high R-output if A/B are floating.

IsoLoop® is a registered trademark of NVE Corporation.

*U.S. Patent number 5,831,426; 6,300,617 and others.

Absolute Maximum Ratings⁽⁶⁾

Parameter	Symbol	Min.	Typ.	Max.	Units	Test Conditions
Storage Temperature	T_S	-55		150	°C	
Junction Temperature	T_J	-55		150	°C	
Voltage Range at A or B Bus Pins		-8		12.5	V	
Supply Voltage ⁽¹⁾	V_{DD1}, V_{DD2}	-0.5		7	V	
Digital Input Voltage		-0.5		$V_{DD} + 0.5$	V	
Digital Output Voltage		-0.5		$V_{DD} + 1$	V	
ESD (all bus nodes)		7			kV	HBM

Recommended Operating Conditions

Parameter	Symbol	Min.	Typ.	Max.	Units	Test Conditions
Supply Voltage	V_{DD1} V_{DD2}	3.0 4.5		5.5 5.5	V	
Ambient Operating Temperature IL3085-1E, IL3085-3E, IL3085E IL3085TE	T_A	-40		85 125	°C	
Junction Temperature IL3085-1E, IL3085-3E, IL3085E IL3085TE	T_J	-40		100 140	°C	
Input Voltage at any Bus Terminal (separately or common mode)	V_I V_{IC}			12 -7	V	
High-Level Digital Input Voltage	V_{IH}	2.4 3.0		V_{DD1}	V	$V_{DD1} = 3.3\text{ V}$ $V_{DD1} = 5.0\text{ V}$
Low-Level Digital Input Voltage	V_{IL}	0		0.8	V	
Differential Input Voltage ⁽²⁾	V_{ID}			+12 / -7	V	
High-Level Output Current (Driver)	I_{OH}			60	mA	
High-Level Digital Output Current (Receiver)	I_{OH}			8	mA	
Low-Level Output Current (Driver)	I_{OL}	-60			mA	
Low-Level Digital Output Current (Receiver)	I_{OL}	-8			mA	
Digital Input Signal Rise and Fall Times	t_{IR}, t_{IF}					DC Stable

Insulation Specifications

Parameter	Symbol	Min.	Typ.	Max.	Units	Test Conditions
Creepage Distance (external)	IL3085-1 IL3085-3 IL3085	3.2 4.0 8.03	8.3		mm	Per IEC 60601
Total Barrier Thickness (internal)		0.012	0.013		mm	
Barrier Resistance	R_{IO}		$>10^{14}$		Ω	500 V
Barrier Capacitance	C_{IO}		7		pF	f = 1 MHz
Leakage Current			0.2		μA_{RMS}	240 V_{RMS} , 60 Hz
Comparative Tracking Index	CTI	≥ 175			V	Per IEC 60112
High Voltage Endurance (Maximum Barrier Voltage for Indefinite Life)	AC DC	V_{IO}	1000 1500		V_{RMS} V_{DC}	At maximum operating temperature
Barrier Life			44000		Years	100°C, 1000 V_{RMS} , 60% CL activation energy

Safety and Approvals

IEC 60747-17 (VDE 0884-17):2021-10 (Basic Isolation; VDE File Number 5016933-4880-0001):

- Isolation voltage (V_{ISO}): 2500 V_{RMS}
- Transient overvoltage (V_{IOTM}): 4000 V_{PK}
- Surge rating 4000 V
- Each part tested at 1590 V_{PK} for 1 second, 5 pC partial discharge limit
- Samples tested at 4000 V_{PK} for 60 sec.; then 1358 V_{PK} for 10 sec. with 5 pC partial discharge limit

- Working Voltage (V_{IORM} ; pollution degree 2):

Package	Part No. Suffix	Working Voltage
QSOP16	-1	600 V_{RMS}
Narrow-body SOIC16	-3	700 V_{RMS}
Wide-body SOIC16/True 8™	None	600 V_{RMS}

Safety-Limiting Values	Symbol	Value	Units
Safety rating ambient temperature	T_S	180	°C
Safety rating power (180°C)	P_S	270	mW
Supply current safety rating (total of supplies)	I_S	54	mA

UL 1577 (Component Recognition Program File Number E207481)

Each part tested at 3000 V_{RMS} (4240 V_{PK}) for 1 second; each lot sample tested at 2500 V_{RMS} (3530 V_{PK}) for 1 minute

Soldering Profile

Per JEDEC J-STD-020C, MSL 1

IL3085-1 (QSOP Package) Pin Connections

1	V _{DD1}	Input power supply
2	R	Output data from bus
3	GND ₁	Input power supply ground return
4	$\overline{\text{RE}}$	Read data enable (if RE is high, R= high impedance)
5	DE	Drive enable
6	D	Data input to bus
7, 8	NC	No internal connection
9	A	Non-inverting bus line
10	B	Inverting bus line
11	V _{DD2X}	Output transceiver power supply (normally connected to pin 16)
12	XDE	Transceiver Device Enable input enables the transceiver from the bus side, or is connected to ISODE to enable the transceiver from the controller-side DE input. (this input should not be left unterminated)
13	ISOR	Isolated R output (for testing; no connection should be made to this pin)
14	GND ₂	Output power supply ground return.
15	ISODE	Isolated DE output (normally connected to pin 12)
16	V _{DD2I}	Output isolation power supply (normally connected to pin 11)

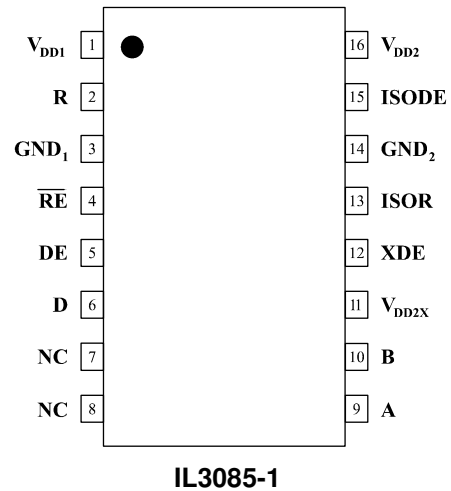

IL3085-3 (0.15" SOIC Package) Pin Connections

1	V _{DD1}	Input power supply
2	GND ₁	Input power supply ground return
3	R	Output data from bus
4	$\overline{\text{RE}}$	Read data enable (if RE is high, R= high impedance)
5	D	Data input to bus
6	DE	Drive enable
7, 8, 9	NC	No internal connection
10	XDE	Transceiver Device Enable input enables the transceiver from the bus side, or is connected to ISODE to enable the transceiver from the controller-side DE input. (this input should not be left unterminated)
11	A	Non-inverting bus line
12	B	Inverting bus line
13	V _{DD2X}	Output transceiver power supply (normally connected to pin 16)
14	ISODE	Isolated DE output (normally connected to pin 10)
15	GND ₂	Output power supply ground return.
16	V _{DD2I}	Output isolation power supply (normally connected to pin 13)

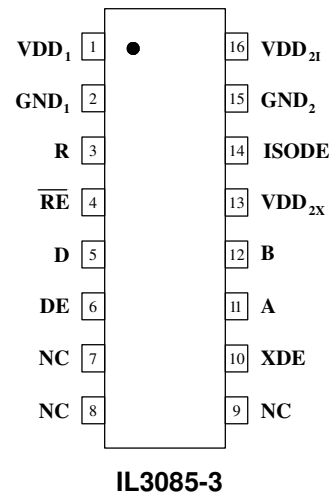

IL3085 / IL3085T (0.3" SOIC Package) Pin Connections

1	V _{DD1}	Input power supply
2	GND ₁	Input power supply ground return (pin 2 is internally connected to pin 8)
3	R	Output data from bus
4	$\overline{\text{RE}}$	Read data enable (if $\overline{\text{RE}}$ is high, R= high impedance)
5	DE	Drive enable
6	D	Data input to bus
7	NC	No internal connection
8	GND ₁	Input power supply ground return (pin 8 is internally connected to pin 2)
9	GND ₂	Output power supply ground return (pin 9 is internally connected to pin 15)
10	ISODE	Isolated DE output for use in PROFIBUS applications where the state of the isolated drive enable node needs to be monitored.
11	NC	No internal connection
12	A	Non-inverting bus line
13	B	Inverting bus line
14	NC	No internal connection
15	GND ₂	Output power supply ground return (pin 15 is internally connected to pin 9)
16	V _{DD2}	Output power supply

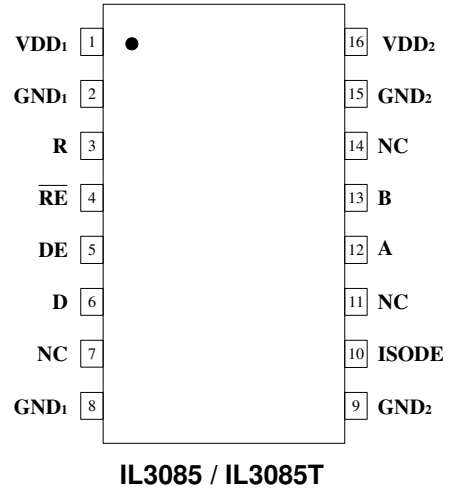

Driver Section

Electrical Specifications (T _{min} to T _{max} and V _{DD} = 4.5 V to 5.5 V unless otherwise stated)						
Parameter	Symbol	Min.	Typ.	Max.	Units	Test Conditions
Output voltage	V _O			V _{DD}	V	I _O = 0
Differential Output Voltage ⁽²⁾	V _{OD1}			V _{DD}	V	I _O = 0
Differential Output Voltage ⁽²⁾	V _{OD3}	1.5	2.3	5	V	R _L = 54 Ω, V _{DD} = 4.5 V
Change in Magnitude of Differential Output Voltage ⁽³⁾	Δ V _{OD1}		±0.01	±0.2	V	R _L = 54 Ω or 100 Ω
Common Mode Output Voltage	V _{OC}			3	V	R _L = 54 Ω or 100 Ω
Change in Magnitude of Common Mode Output Voltage ⁽³⁾	Δ V _{OC1}		±0.01	±0.2	V	R _L = 54 Ω or 100 Ω
Output Current	I _O			1 -0.8	mA	Output Disabled, V _O = 12 V _O = -7
High Level Input Current	I _{IH}			10	μA	V _I = 3.5 V
Low Level Input Current	I _{IL}			-10	μA	V _I = 0.4 V
Absolute Short-circuit Output Current	I _{OS}			250	mA	-7 V < V _O < 12 V
Supply Current	I _{DD1} I _{DD1}		4 3	6 4	mA	No Load (Outputs Enabled)

Receiver Section

Electrical Specifications (T _{min} to T _{max} and V _{DD} = 4.5 V to 5.5 V unless otherwise stated)						
Parameter	Symbol	Min.	Typ.	Max.	Units	Test Conditions
Positive-going Input Threshold Voltage	V _{IT+}			0.2	V	-7 V < V _{CM} < 12 V
Negative-going Input Threshold Voltage	V _{IT-}	-0.2			V	-7 V < V _{CM} < 12 V
Hysteresis Voltage (V _{IT+} - V _{IT-})	V _{HYS}		70		mV	V _{CM} = 0 V, T = 25°C
High Level Digital Output Voltage	V _{OH}	V _{DD} - 0.2	V _{DD}		V	V _{ID} = 200 mV I _{OH} = -20 μA
Low Level Digital Output Voltage	V _{OL}			0.2	V	V _{ID} = -200 mV I _{OH} = 20 μA
High-Impedance-State Output Current	I _{OZ}			±1	μA	V _O = 0.4 to (V _{DD2} -0.5) V
Line Input Current ⁽⁸⁾	I _I			1 -0.8	mA	V _I = 12 V V _I = -7 V
Input Resistance	R _I	12			kΩ	
Supply Current	I _{DD2}		5	16	mA	No load; Outputs Enabled; V _{DD2x} connected to V _{DD21} if applicable

Power Consumption

T _{min} to T _{max} and V _{DD2} = 5 V unless otherwise stated						
Parameter	Symbol	Min.	Typ.	Max.	Units	Test Conditions
Controller-Side Quiescent Current	I _{DD1}		3 4	4 6	mA	f _{IN} = 0 Hz
Bus-Side Quiescent Supply Current	I _{DD2}		5	16	mA	Outputs Enabled; R _T = ∞; f _{IN} = 0 Hz ; V _{DD2x} connected to V _{DD21} if applicable
Controller-Side Dynamic Supply Current	I _{DD1}		0.22		mA/Mbps	V _{DD1} = 3.3 V
Bus-Side Dynamic Supply Current	ΔI _{DD2} /Δf _{IN}		1 0.8			R _T = ∞ R _T = 60 Ω

Switching Characteristics

V _{DD1} = 5 V, V _{DD2} = 5 V						
Parameter	Symbol	Min.	Typ.	Max.	Units	Test Conditions
Data Rate		4			Mbps	R _L = 54 Ω, C _L = 50 pF
Propagation Delay ⁽⁴⁾	t _{PD}		48	150	ns	V _O = -1.5 to 1.5 V, C _L = 15 pF
Pulse Skew ⁽⁵⁾	t _{SK(P)}		6	15	ns	V _O = -1.5 to 1.5 V, C _L = 15 pF
Output Enable Time To High Level	t _{PZH}		33	50	ns	C _L = 15 pF
Output Enable Time To Low Level	t _{PZL}		33	50	ns	C _L = 15 pF
Output Disable Time From High Level	t _{PHZ}		33	50	ns	C _L = 15 pF
Output Disable Time From Low Level	t _{PLZ}		33	50	ns	C _L = 15 pF
Common Mode Transient Immunity (Output Logic High to Logic Low)	CM _H , CM _L	30	50		kV/μs	V _{CM} = 1500 V _{DC} t _{TRANSIENT} = 25 ns
V _{DD1} = 3.3 V, V _{DD2} = 5 V						
Parameter	Symbol	Min.	Typ.	Max.	Units	Test Conditions
Data Rate		4			Mbps	R _L = 54 Ω, C _L = 50 pF
Propagation Delay ⁽⁴⁾	t _{PD}	-40 to +85 °C	48	150	ns	V _O = -1.5 to 1.5 V, C _L = 15 pF
		-40 to +125 °C	58	155		
Pulse Skew ⁽⁵⁾	t _{SK(P)}		6	20	ns	V _O = -1.5 to 1.5 V, C _L = 15 pF
Output Enable Time To High Level	t _{PZH}		33	50	ns	C _L = 15 pF
Output Enable Time To Low Level	t _{PZL}		33	50	ns	C _L = 15 pF
Output Disable Time From High Level	t _{PHZ}		33	50	ns	C _L = 15 pF
Output Disable Time From Low Level	t _{PLZ}		33	50	ns	C _L = 15 pF
Common Mode Transient Immunity (Output Logic High to Logic Low)	CM _H , CM _L	30	50		kV/μs	V _{CM} = 1500 V _{DC} t _{TRANSIENT} = 25 ns

Magnetic Field Immunity⁽⁷⁾

V _{DD1} = 5 V, V _{DD2} = 5 V						
Parameter	Symbol	Min.	Typ.	Max.	Units	Test Conditions
Power Frequency Magnetic Immunity	H _{PF}		3500		A/m	50Hz/60Hz
Pulse Magnetic Field Immunity	H _{PM}		4500		A/m	t _p = 8μs
Damped Oscillatory Magnetic Field	H _{OSC}		4500		A/m	0.1Hz – 1MHz
Cross-axis Immunity Multiplier ⁽⁸⁾	K _X		2.5			
V _{DD1} = 3.3 V, V _{DD2} = 5 V						
Parameter	Symbol	Min.	Typ.	Max.	Units	Test Conditions
Power Frequency Magnetic Immunity	H _{PF}		1500		A/m	50Hz/60Hz
Pulse Magnetic Field Immunity	H _{PM}		2000		A/m	t _p = 8μs
Damped Oscillatory Magnetic Field	H _{OSC}		2000		A/m	0.1Hz – 1MHz
Cross-axis Immunity Multiplier ⁽⁸⁾	K _X		2.5			

Thermal Characteristics

Parameter	Symbol	Min.	Typ.	Max.	Units	Test Conditions
Junction–Ambient Thermal Resistance	θ _{JA}		100			Double-sided PCB in free air
			82			
Junction–Case (Top) Thermal Resistance	θ _{JC}		9			
			8			
Junction–Ambient Thermal Resistance	θ _{JA}		46			2s2p PCB in free air per JESD51
			9			
Junction–Case (Top) Thermal Resistance	θ _{JC}					
Power Dissipation	P _D			675	mW	
				700		
				1500		

Notes:

1. All voltages are with respect to network ground except differential I/O bus voltages.
2. Differential input/output voltage is measured at the noninverting terminal A with respect to the inverting terminal B.
3. $\Delta|V_{OD}|$ and $\Delta|V_{OC}|$ are the changes in magnitude of V_{OD} and V_{OC} , respectively, that occur when the input is changed from one logic state to the other.
4. Includes 10 ns read enable time. Maximum propagation delay is 25 ns after read assertion.
5. Pulse skew is defined as $|t_{PLH} - t_{PHL}|$ of each channel.
6. Absolute Maximum specifications mean the device will not be damaged if operated under these conditions. It does not guarantee performance.
7. The relevant test and measurement methods are given in the Electromagnetic Compatibility section on p. 9.
8. External magnetic field immunity is improved by this factor if the field direction is “end-to-end” rather than to “pin-to-pin.”

Electrostatic Discharge Sensitivity

This product has been tested for electrostatic sensitivity to the limits stated in the specifications. However, NVE recommends that all integrated circuits be handled with appropriate care to avoid damage. Damage caused by inappropriate handling or storage could range from performance degradation to complete failure.

Pinout Differences Between Packages

QSOP and narrow-body version (IL3085-1E and IL3085-3E) are designed for application flexibility and minimum board area in dense PCAs. The wide-body version (IL3085E) has redundant ground pins for layout flexibility.

QSOP and narrow-body versions provide separate isolated DE output (ISODE) and Transceiver Device Enable (XDE) input. ISODE follows the Device Enable input (DE). XDE can be used to enable and disable the transceiver from the bus side, or connected to ISODE to enable and disable the transceiver from the DE controller-side input. The QSOP and narrow-body versions also provide separate bus-side power supply pins— V_{DD2X} for the transceiver module and V_{DD2I} for the isolation module. These should be externally connected for normal operation, but can be used separately for testing or troubleshooting. The QSOP version also has an “ISOR” output that is isolated with respect to the controller-side “R.” This pin is used for testing and normally not connected, but could be used for a bus-side data output under special circumstances.

The wide-body version has internal connections between the isolated DE output and the Transceiver Device Enable input, and well as between the two V_{DD2} bus-side power supply pins. The two internally-connected GND pins for each supply side provide layout flexibility. The ISODE output can be used in PROFIBUS applications where the state of the isolated drive enable node needs to be monitored, or for testing or troubleshooting.

Power Supply Decoupling

V_{DD1} and V_{DD2} should be bypassed with 0.1 μF typical (0.047 μF minimum) capacitors as close as possible to the V_{DD} pins.

Maintaining Creepage

Creepage distances are often critical in isolated circuits. In addition to meeting JEDEC standards, NVE isolator packages have unique creepage specifications. Standard pad libraries often extend under the package, compromising creepage and clearance. Similarly, ground planes, if used, should be spaced to avoid compromising clearance. Package drawings and recommended pad layouts are included in this datasheet.

DC Correctness

The IL3085 incorporates a patented refresh circuit to maintain the correct output state with respect to data input. At power up, the bus outputs will follow the Function Table shown on Page 1. The DE input should be held low during power-up to eliminate false drive data pulses from the bus. An external power supply monitor to minimize glitches caused by slow power-up and power-down transients is not required.

Electromagnetic Compatibility

The IL3085 is fully compliant with IEC 61000-6-1 and IEC 61000-6-2 standards for immunity, and IEC 61000-6-3, IEC 61000-6-4, CISPR, and FCC Class A standards for emissions.

The IsoLoop Isolator’s Wheatstone bridge configuration and differential magnetic field signaling ensure excellent EM immunity. Immunity to external magnetic fields is even higher if the field direction is “end-to-end” (rather than to “pin-to-pin”) as shown at right.

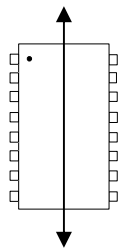

Application Information

Figures 1a, 1b, and 1c show typical connections to a bus and microcontroller for the three package versions. The schematics include typical termination and fail-safe resistors, and power supply decoupling capacitors:

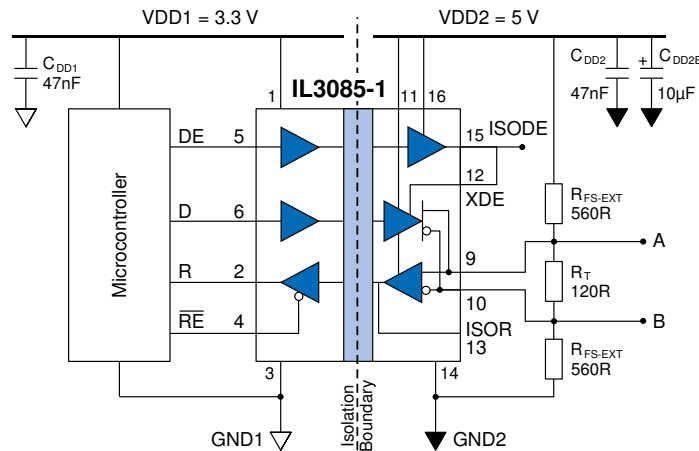

Figure 1a. Typical QSOP transceiver connections.

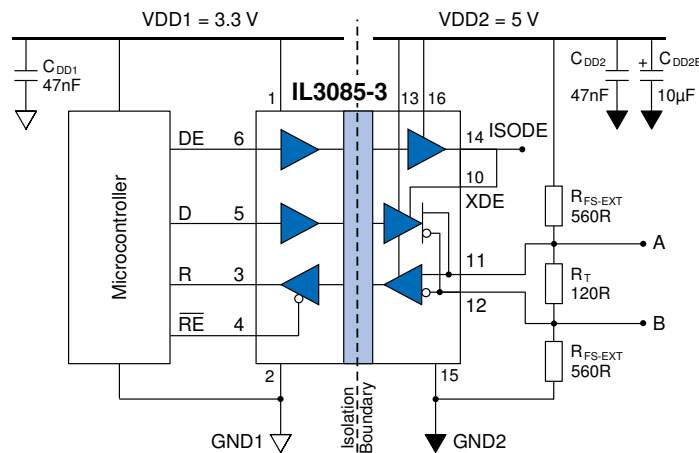

Figure 1b. Typical narrow-body connections.

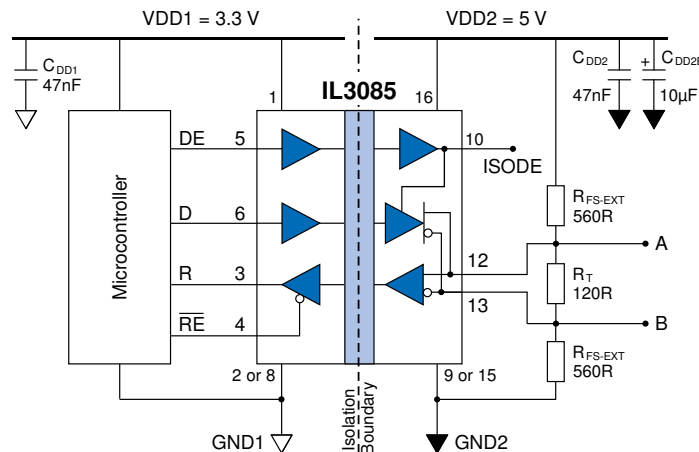

Figure 1c. Typical wide-body connections.

Receiver Features

The receiver output “R” has tri-state capability via the active low \overline{RE} input.

Driver Features

The RS-485 driver has a differential output and delivers at least 2.1 V across a 54 Ω load. Drivers feature low propagation delay skew to maximize bit width and minimize EMI. Drivers have tri-state capability via the active-high DE input.

Receiver Data Rate, Cables and Terminations

The IL3085 is intended for networks up to 4,000 feet (1,200 m), but the maximum data rate decreases as cable length increases. Twisted pair cable should be used in all networks since they tend to pick up noise and other electromagnetically induced voltages as common mode signals, which are effectively rejected by the differential receiver.

Fail-Safe Operation

“Fail-safe operation” is defined here as the forcing of a logic high state on the “R” output in response to an open-circuit condition between the “A” and “B” lines of the bus, or when no drivers are active on the bus.

Proper biasing can ensure fail-safe operation, that is a known state when there are no active drivers on the bus. IL3000-Series Isolated Transceivers include internal pull-up and pull-down resistors of approximately 30 k Ω in the receiver section (R_{FS-INT} ; see figure below). These internal resistors are designed to ensure failsafe operation but only if there are no termination resistors. The entire V_{DD} will appear between inputs “A” and “B” if there is no loading and no termination resistors, and there will be more than the required 200 mV with up to four RS-485 worst-case Unit Loads of 12 k Ω . Many designs operating below 1 Mbps or less than 1,000 feet are unterminated. Termination resistors may not be necessary for very low data rates and very short cable runs because reflections have time to settle before data sampling, which occurs at the middle of the bit interval.

In busses with low-impedance termination resistors however, the differential voltage across the conductor pair will be close to zero with no active drivers. In this case the state of the bus is indeterminate, and the idle bus will be susceptible to noise. For example, with 120 Ω termination resistors (R_T) on each end of the cable, and four Unit Loads (12 k Ω each), without external fail-safe biasing resistors the internal pull-up and pull-down resistors will produce a voltage between inputs “A” and “B” of only about 5 mV. This is not nearly enough to ensure a known state. External fail-safe biasing resistors (R_{FS-EXT}) at one end of the bus can ensure fail-safe operation with a terminated bus. Resistors should be selected so that under worst-case power supply and resistor tolerances there is at least 200 mV across the conductor pair with no active drivers to meet the input sensitivity specification of the RS-485 standard.

Using the same value for pull-up and pull-down biasing resistors maintains balance for positive- and negative going transitions. Lower-value resistors increase inactive noise immunity at the expense of quiescent power consumption. Note that each Unit Load on the bus adds a worst-case loading of 12 k Ω across the conductor pair, and 32 Unit Loads add 375 Ω worst-case loading. The more loads on the bus, the lower the required values of the biasing resistors.

In the example with two 120 Ω termination resistors and four Unit Loads, 560 Ω external biasing resistors provide more than 200 mV between “A” and “B” with adequate margin for power supply variations and resistor tolerances. This ensures a known state when there are no active drivers. Other illustrative examples are shown in the following table:

Fail-Safe Biasing

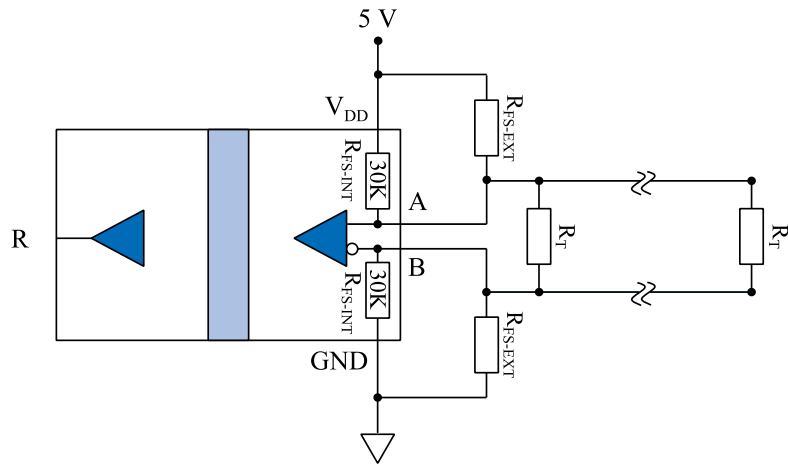

R_{FS-EXT}	R_T	Loading	Nominal V_{A-B} (inactive)	Fail-Safe Operation?
Internal Only	None	Four unit loads (12 k Ω ea.)	238 mV	Yes
Internal Only	120 Ω	Four unit loads (12 k Ω ea.)	5 mV	No
560 Ω	120 Ω	Four unit loads (12 k Ω ea.)	254 mV	Yes
510 Ω	120 Ω	32 unit loads (12 k Ω ea.)	247 mV	Yes

Package Drawings

Ultraminiature 16-pin QSOP Package (-1 suffix)

Dimensions in inches (mm); scale = approx. 5X

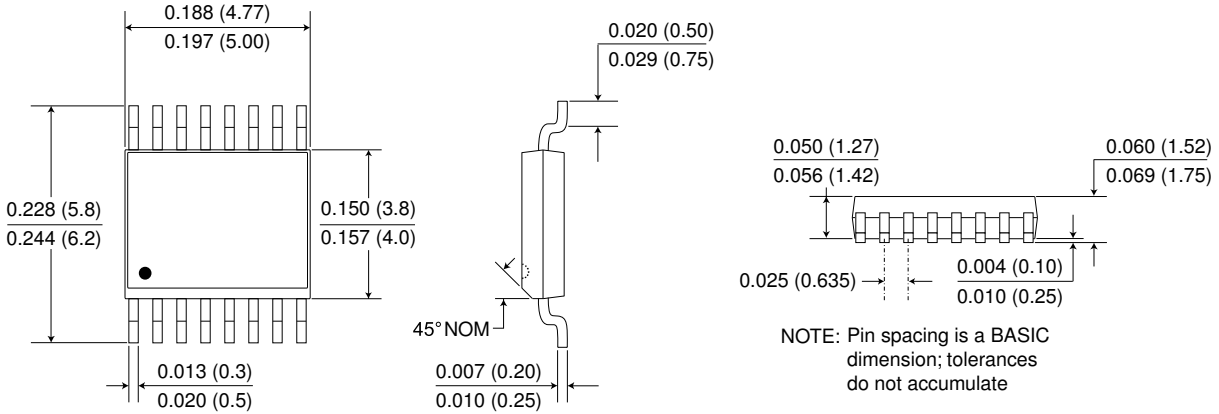

0.15" 16-pin SOIC Package (-3 suffix)

Dimensions in inches (mm); scale = approx. 5X

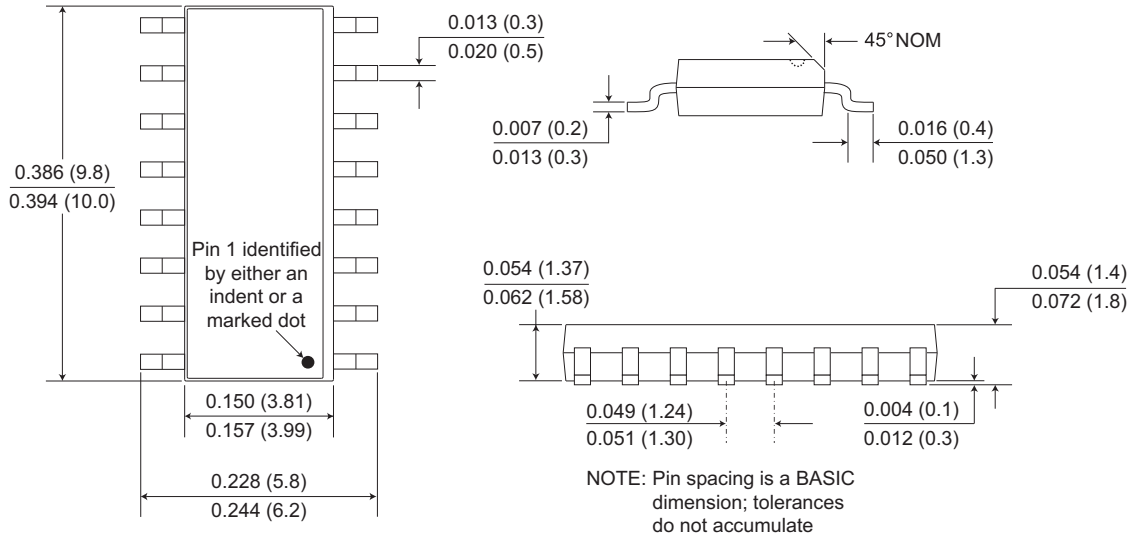

0.3" 16-pin SOIC Package (no suffix)

Dimensions in inches (mm); scale = approx. 5X

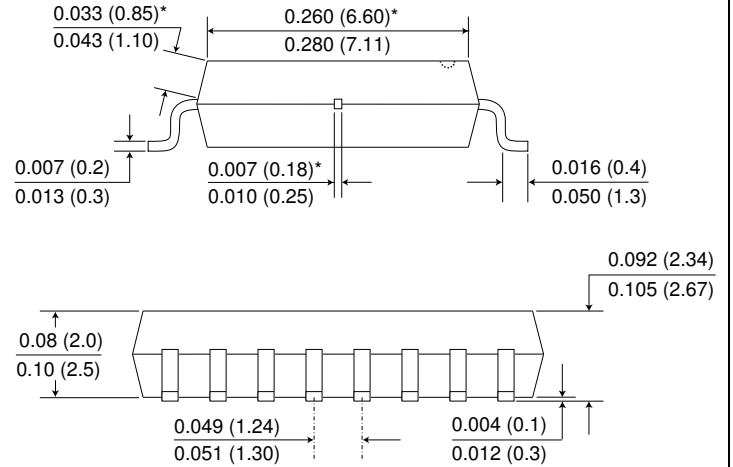
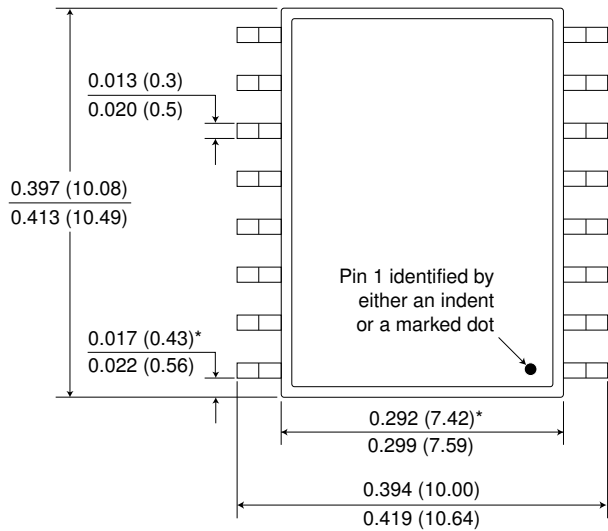

NOTE: Pin spacing is a BASIC dimension; tolerances do not accumulate

*Specified for True 8™ package to guarantee 8 mm creepage per IEC 60601.

Recommended Pad Layouts

4 mm x 5 mm 16-pin QSOP Pad Layout

Dimensions in inches (mm); scale = approx. 5X

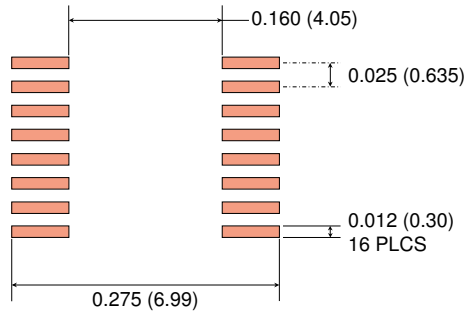

0.15" 16-pin SOIC Pad Layout

Dimensions in inches (mm); scale = approx. 5X

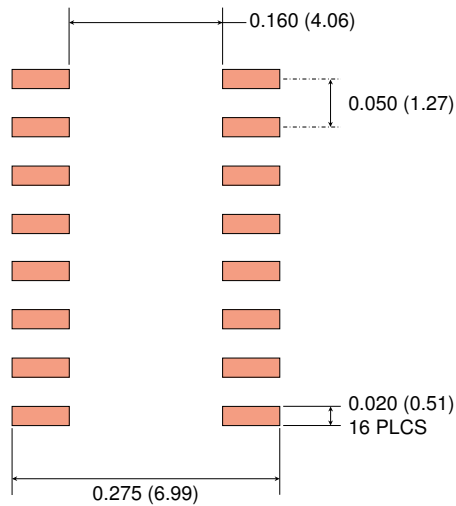

0.3" 16-pin SOIC Pad Layout

Dimensions in inches (mm); scale = approx. 5X

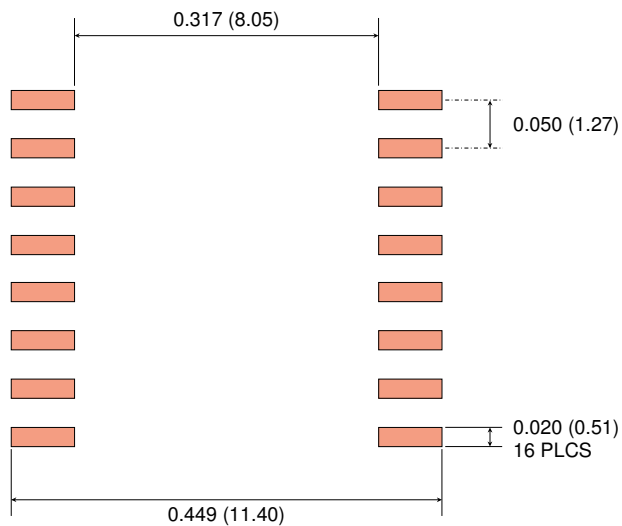

Ordering Information and Valid Part Numbers

IL 30 85 T - 3 E TR13

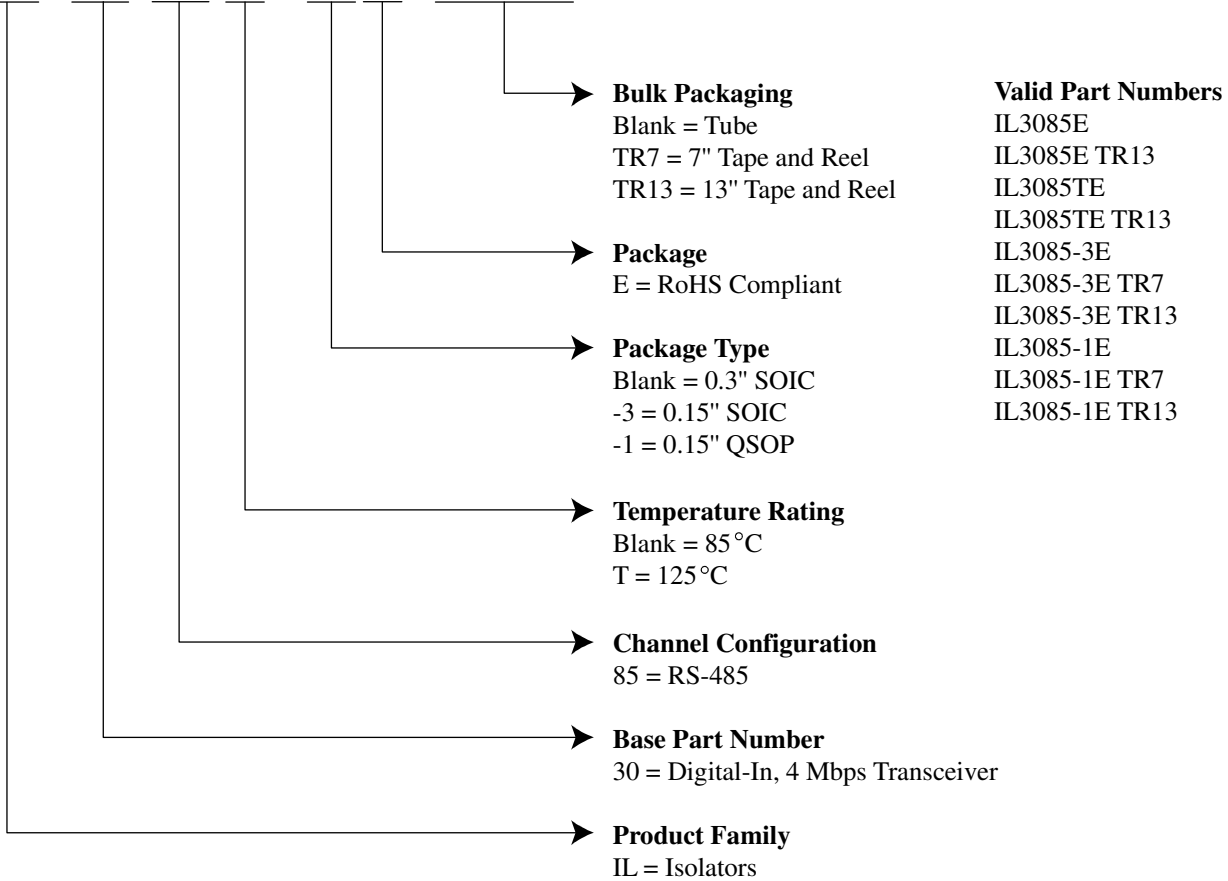

Revision History

ISB-DS-001-IL3085-J
November 2023

Change

- Added 125 °C version (IL3085TE).

ISB-DS-001-IL3085-I

Changes

- Upgrade to VDE 0884-17 (p. 3).
- Increased Working Voltage ratings based on latest VDE testing (p. 3).
- Separate power consumption specifications section; added dynamic power consumption (p. 6).
- Updated thermal specifications (p. 7).
- Updated EMC standards.

ISB-DS-001-IL3085-H

Change

- Improved thermal specifications based on new test data (p. 2).

ISB-DS-001-IL3085-G

Change

- Updated from IEC 60747-5-5 (VDE 0884) certification to VDE V 0884-10.

ISB-DS-001-IL3085-F

Change

- Increased IL3085-1E (QSOP) creepage specification from 2.75 mm to 3.2 mm (p. 2).

ISB-DS-001-IL3085-E

Changes

- Added QSOP version (-1 suffix).
- Revised and added details to thermal characteristic specifications (p. 2).
- Added VDE 0884 Safety-Limiting Values (p. 3).

ISB-DS-001-IL3085-D

Changes

- IEC 60747-5-5 (VDE 0884) certification.
- Upgraded from MSL 2 to MSL 1.

ISB-DS-001-IL3085-C

Changes

- Increased transient immunity specifications based on additional data.
- Noted UL 1577 recognition, IEC 61010-1 approval, and VDE 0884 pending.
- Added transient immunity specifications.
- Added high voltage endurance specification.
- Increased magnetic immunity specifications.
- Updated package outline drawings and added recommended solder pad dimensions.

ISB-DS-001-IL3085-A
December 2012

Change

- Initial Release.

Datasheet Limitations

The information and data provided in datasheets shall define the specification of the product as agreed between NVE and its customer, unless NVE and customer have explicitly agreed otherwise in writing. All specifications are based on NVE test protocols. In no event however, shall an agreement be valid in which the NVE product is deemed to offer functions and qualities beyond those described in the datasheet.

Limited Warranty and Liability

Information in this document is believed to be accurate and reliable. However, NVE does not give any representations or warranties, expressed or implied, as to the accuracy or completeness of such information and shall have no liability for the consequences of use of such information.

In no event shall NVE be liable for any indirect, incidental, punitive, special or consequential damages (including, without limitation, lost profits, lost savings, business interruption, costs related to the removal or replacement of any products or rework charges) whether or not such damages are based on tort (including negligence), warranty, breach of contract or any other legal theory.

Right to Make Changes

NVE reserves the right to make changes to information published in this document including, without limitation, specifications and product descriptions at any time and without notice. This document supersedes and replaces all information supplied prior to its publication.

Use in Life-Critical or Safety-Critical Applications

Unless NVE and a customer explicitly agree otherwise in writing, NVE products are not designed, authorized or warranted to be suitable for use in life support, life-critical or safety-critical devices or equipment. NVE accepts no liability for inclusion or use of NVE products in such applications and such inclusion or use is at the customer's own risk. Should the customer use NVE products for such application whether authorized by NVE or not, the customer shall indemnify and hold NVE harmless against all claims and damages.

Applications

Applications described in this datasheet are illustrative only. NVE makes no representation or warranty that such applications will be suitable for the specified use without further testing or modification.

Customers are responsible for the design and operation of their applications and products using NVE products, and NVE accepts no liability for any assistance with applications or customer product design. It is customer's sole responsibility to determine whether the NVE product is suitable and fit for the customer's applications and products planned, as well as for the planned application and use of customer's third party customers. Customers should provide appropriate design and operating safeguards to minimize the risks associated with their applications and products.

NVE does not accept any liability related to any default, damage, costs or problem which is based on any weakness or default in the customer's applications or products, or the application or use by customer's third party customers. The customer is responsible for all necessary testing for the customer's applications and products using NVE products in order to avoid a default of the applications and the products or of the application or use by customer's third party customers. NVE accepts no liability in this respect.

Limiting Values

Stress above one or more limiting values (as defined in the Absolute Maximum Ratings System of IEC 60134) will cause permanent damage to the device. Limiting values are stress ratings only and operation of the device at these or any other conditions above those given in the recommended operating conditions of the datasheet is not warranted. Constant or repeated exposure to limiting values will permanently and irreversibly affect the quality and reliability of the device.

Terms and Conditions of Sale

In case an individual agreement is concluded only the terms and conditions of the respective agreement shall apply. NVE hereby expressly objects to applying the customer's general terms and conditions with regard to the purchase of NVE products by customer.

No Offer to Sell or License

Nothing in this document may be interpreted or construed as an offer to sell products that is open for acceptance or the grant, conveyance or implication of any license under any copyrights, patents or other industrial or intellectual property rights.

Export Control

This document as well as the items described herein may be subject to export control regulations. Export might require a prior authorization from national authorities.

Automotive Qualified Products

Unless the datasheet expressly states that a specific NVE product is automotive qualified, the product is not suitable for automotive use. It is neither qualified nor tested in accordance with automotive testing or application requirements. NVE accepts no liability for inclusion or use of non-automotive qualified products in automotive equipment or applications.

In the event that customer uses the product for design-in and use in automotive applications to automotive specifications and standards, customer (a) shall use the product without NVE's warranty of the product for such automotive applications, use and specifications, and (b) whenever customer uses the product for automotive applications beyond NVE's specifications such use shall be solely at customer's own risk, and (c) customer fully indemnifies NVE for any liability, damages or failed product claims resulting from customer design and use of the product for automotive applications beyond NVE's standard warranty and NVE's product specifications.

An ISO 9001 Certified Company

NVE Corporation
11409 Valley View Road
Eden Prairie, MN 55344-3617 USA
Telephone: (952) 829-9217
www.nve.com
e-mail: iso-info@nve.com

©NVE Corporation
All rights are reserved. Reproduction in whole or in part is prohibited without the prior written consent of the copyright owner.

ISB-DS-001-IL3085-J

November 2023

Looking for pricing, stock, or lifecycle information?

Click below to explore more details on WIN SOURCE:

 [View IL 3085E on WIN SOURCE](#)

 [NVE Corp Information](#)

Optimize Your Supply Chain with WIN SOURCE Solutions

-  Global Sourcing Solution
-  Obsolete Management
-  Cost Control Management
-  Shortage Management
-  Alternative Solution
-  Excess Inventory Management