



**THE DATASHEET OF
89H32NT24BG2ZCHLGI**





IDT™ EB-LOGAN-23 Evaluation Board Manual

(Evaluation Board: 18-691-001)

February 2011

6024 Silver Creek Valley Road, San Jose, California 95138
Telephone: (800) 345-7015 • (408) 284-8200 • FAX: (408) 284-2775
Printed in U.S.A.
©2011 Integrated Device Technology, Inc.

DISCLAIMER

Integrated Device Technology, Inc. reserves the right to make changes to its products or specifications at any time, without notice, in order to improve design or performance and to supply the best possible product. IDT does not assume any responsibility for use of any circuitry described other than the circuitry embodied in an IDT product. The Company makes no representations that circuitry described herein is free from patent infringement or other rights of third parties which may result from its use. No license is granted by implication or otherwise under any patent, patent rights or other rights, of Integrated Device Technology, Inc.

Boards that fail to function should be returned to IDT for replacement. Credit will not be given for the failed boards nor will a Failure Analysis be performed.

LIFE SUPPORT POLICY

Integrated Device Technology's products are not authorized for use as critical components in life support devices or systems unless a specific written agreement pertaining to such intended use is executed between the manufacturer and an officer of IDT.

1. Life support devices or systems are devices or systems which (a) are intended for surgical implant into the body or (b) support or sustain life and whose failure to perform, when properly used in accordance with instructions for use provided in the labeling, can be reasonably expected to result in a significant injury to the user.
2. A critical component is any components of a life support device or system whose failure to perform can be reasonably expected to cause the failure of the life support device or system, or to affect its safety or effectiveness.

IDT, the IDT logo, and Integrated Device Technology are trademarks or registered trademarks of Integrated Device Technology, Inc.



Notes

Description of the EB-LOGAN-23 Evaluation Board

Introduction 1-1
 Board Features 1-2
 Hardware 1-2
 Software..... 1-2
 Other..... 1-2
 Revision History 1-2

Installation of the EB-LOGAN-23 Evaluation Board

EB-LOGAN-23 Installation 2-1
 PCI Express Mezzanine and Edge Adapters 2-1
 Hardware Description 2-3
 Reference Clocks..... 2-4
 Global Reference Input Clocks 2-4
 Local Port Input Clocks 2-6
 CLKMODE Selection 2-8
 Power Sources 2-9
 PCI Express Analog Power Voltage Regulator 2-10
 PCI Express Digital Power Voltage Converter 2-10
 PCI Express Transmitter Analog Voltage Converter 2-10
 Core Logic Voltage Converter 2-10
 3.3V I/O Voltage Regulator 2-10
 Power-up Sequence for PES32NT24AG2 2-10
 Heatsink Requirement 2-10
 Reset..... 2-10
 Fundamental Reset 2-10
 Downstream Reset 2-11
 Stack Configuration 2-11
 Boot Configuration Vector 2-11
 SMBus Interfaces..... 2-12
 SMBus Slave Interface 2-12
 SMBus Master Interface 2-13
 JTAG Header 2-13
 Miscellaneous Jumpers, Headers 2-14
 LEDs 2-15
 EB-LOGAN-23 Board Figure 2-23

Software For EB-LOGAN-23

Introduction 3-1
 Device Management Software 3-1
 Device Drivers..... 3-1

Schematics

Schematics 4-1

Notes



List of Figures

Notes

Figure 1.1	Function Block Diagram of the EB-LOGAN-23 Evaluation Board	1-1
Figure 2.1	Bifurcated and Merged Mezzanine Cards	2-1
Figure 2.2	MiniSAS Mezzanine Adapter	2-2
Figure 2.3	EB-LOGAN-23 iSAS-to-SATA Breakout Cable	2-2
Figure 2.4	EB-LOGAN-23 iSAS-to-iSAS Cable	2-2
Figure 2.5	PCIe x4 Edge-to-SATA Adapter	2-3
Figure 2.6	PCIe x8 Edge-to-SAS Adapter	2-3
Figure 2.7	EB-LOGAN-23 Evaluation Main Board	2-4
Figure 2.8	12-PACK PCIe Slots Breakout Board	2-4
Figure 2.9	Differential Jumper Arrangement Example	2-5
Figure 2.10	Reference Clock Configuration	2-5
Figure 2.11	EB32NT24AG2 Evaluation Board	2-23

Notes



List of Tables

Notes

Table 2.1	EB-LOGAN-23 Global Clock Select	2-5
Table 2.2	Clock Buffer Input Sources	2-6
Table 2.3	Global Reference Input Clock Frequency Select	2-6
Table 2.4	Onboard Clock Generator Frequency Select	2-6
Table 2.5	Onboard Reference Clock Generator Access Points	2-6
Table 2.6	EB-LOGAN-23 Port (0, 2, 4, 6, 12, 20) Clock Select	2-7
Table 2.7	EB-LOGAN-23 Port 8 Clock Source Select	2-7
Table 2.8	EB-LOGAN-23 Port 16 Clock Source Select	2-7
Table 2.9	EB-LOGAN-23 Slot Clock Select	2-8
Table 2.10	CLKMODE Selection for the PES32NT24AG2	2-9
Table 2.11	EPS12V 24-pin Power Connector - J69	2-9
Table 2.12	EPS12V 8-Pin Connector - J68	2-9
Table 2.13	Ports in Each Stack	2-11
Table 2.14	Boot Configuration Vector Signals	2-11
Table 2.15	Boot Configuration Vector Switch SW10	2-12
Table 2.16	Slave SMBus Interface Connector	2-12
Table 2.17	SMBus Slave Interface Address Configuration	2-13
Table 2.18	JTAG Connector Pin Out	2-13
Table 2.19	Miscellaneous Jumpers, Headers	2-14
Table 2.20	LED Indicators	2-15

Notes



Description of the EB-LOGAN-23 Evaluation Board

Notes

Introduction

The 89H32NT24AG2 switch (also referred to as PES32NT24AG2 in this manual) is a member of the IDT PCI Express® Inter-Domain Switch family of products. It is a PCIe® Base Specification 2.1 compliant (Gen2) 32-lane, 24-port switch. The EB-LOGAN-23 Evaluation Board provides an evaluation platform for both the PES32NT24AG2 and PES32NT24BG2 switches and for several other members of this switch family including PES24NT24AG2, PES32NT8AG2, and PES24NT6AG2 .

Detailed information related to configuration of number of ports and lanes in the switch device can be found in the Device User Manual and the Device Data Sheet. The evaluation board, along with additional adapters and daughter boards provide by IDT, can be configured to test every possible combination of the number of lanes and ports offered by the switch. Advanced capabilities such as switch partitioning, NTB, DMA, and local port clocking can be evaluated with the evaluation board.

The EB-LOGAN-23 brings out all 32 lanes of the device to 4 Mezzanine connectors (see Figure 1.1) located close to the device — one connector per stack of 8 lanes. Various types of daughter cards (provided by IDT) can then be plugged into these connectors to facilitate connectivity to one x8 or two x4 or four x2 or eight x1 link partners. Link partners may be plugged directly into these daughter cards, or they can be connected to these daughter cards via SAS or SATA cables and a different board with PCIe slots known as the 12-PACK board (provided by IDT). Given that the majority of the hosts/servers offer PCIe standard slots, IDT provides the necessary adapter cards that may be plugged into these host/server slots as well as the cables that connect such adapters to the daughter cards, which in turn are plugged into the main evaluation board on which the IDT PCIe switch device is populated.

The EB-LOGAN-23 is also used by IDT to reproduce system-level hardware or software issues reported by customers. Figure 1.1 illustrates the functional block diagram representing the main parts of the EB-LOGAN-23 board.

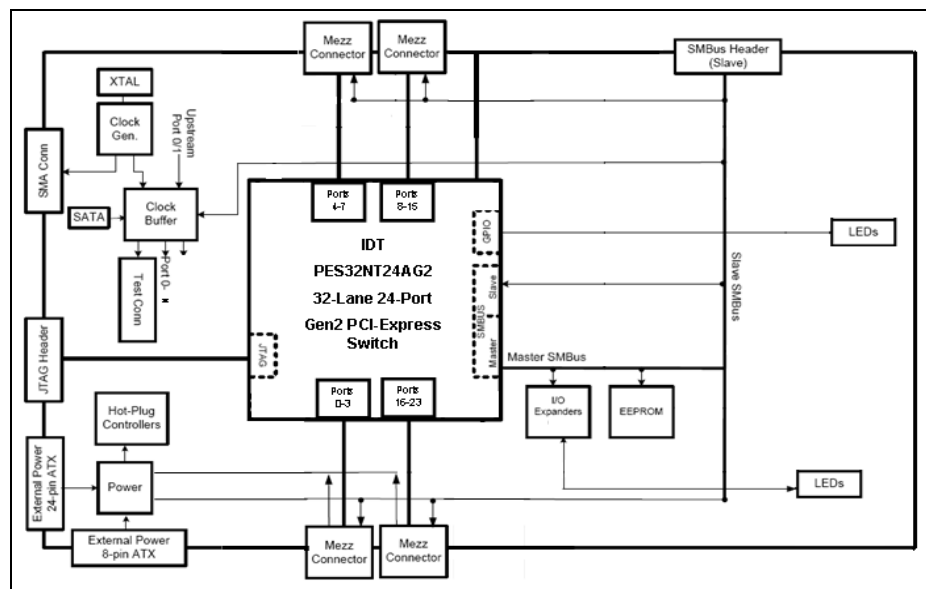

Figure 1.1 Function Block Diagram of the EB-LOGAN-23 Evaluation Board

Notes

Board Features

Hardware

- ◆ **32NT24AG2 PCIe 24-port switch**
 - Twenty four ports (8 x2 and 16 x1) — adjacent ports may be combined to create x4 or x8 ports
 - PCIe Base Specification Revision 2.1 compliant (Gen2 SerDes speeds of 5 GT/S)
 - Up to 2048 byte maximum Payload Size
 - Automatic lane reversal and polarity inversion supported on all lanes
 - Automatic per port link width negotiation to x8, x4, x2, x1
 - Power on reconfiguration via optional serial EEPROM connected to the SMBUS Master interface
- ◆ **Upstream, Downstream Ports**
 - The EB-LOGAN-23 has a minimum of one port configured as an upstream port to be plugged into a host slot through an adaptor and a cable.
 - Up to 23 ports can be configured as downstream ports, for PCIe endpoint add-on cards to be plugged in. The slot connectors can be configured to be x1, x2, x4, or x8, but are mechanically open-ended on one side to allow card widths greater than x8 (e.g. x16) to be populated.
 - When used in multi-partition mode, the device can be programmed through the serial EEPROM to generate the appropriate number of upstream and downstream ports per partition.
- ◆ **Numerous user selectable configurations set using onboard jumpers and DIP-switches**
 - Source of clock - host clock or onboard clock generator
 - Two clock rates (100/125 MHz) from an onboard clock generator
 - Flexible clocking modes
 - *Common clock*
 - *Non-common clock*
 - *Local port clocking on ports that support this feature*
 - Boot mode selection
- ◆ **SMBUS Slave Interface (4 pin header)**
- ◆ **SMBUS Master Interface connected to the Serial EEPROMs and I/O Expanders**
- ◆ **Push button for Warm Reset**
- ◆ **Many LEDs to display status, reset, power, hot-plug, etc.**
- ◆ **JTAG connector to the 32NT24AG2 JTAG pins.**

Software

There is no software or firmware executed on the board. However, useful software is provided along with the Evaluation Board to facilitate configuration and evaluation of the 32NT24AG2 within host systems running popular operating systems.

- ◆ **Installation programs**
 - Operating Systems Supported: WindowsServer200x, WindowsXP, Vista, Linux
- ◆ **GUI based application for Windows and Linux**
 - Allows users to view and modify registers in the 32NT24AG2
 - Binary file generator for programming the serial EEPROMs attached to the SMBUS.

Other

- ◆ SMBUS cable/dongle may be required for certain evaluation exercises.
- ◆ SMA/SATA connectors are provided on the EB-LOGAN-23 board for clock outputs.

Revision History

March 15, 2010: Initial publication of evaluation board manual.

April 23, 2010: Updated Schematics in Chapter 4.

Notes

August 11, 2010: Updated the manual for Rev. 2.0 board.

February 16, 2011: Changed default settings from Off to On in Tables 2.3 and 2.4.

Notes



Installation of the EB-LOGAN-23 Evaluation Board

Notes

EB-LOGAN-23 Installation

This chapter discusses the steps required to configure and install the EB-LOGAN-23 evaluation board. All available DIP switches and jumper configurations are explained in detail.

The primary installation steps are:

1. Configure jumper/switch options suitable for the evaluation or application requirements.
2. Connect PCI Express endpoint cards to the downstream port PCIe slots on the daughter cards plugged into the evaluation board. Daughter cards are provided by IDT. In some cases the 12-PACK board will be required as well (specifically when more ports than those supported by the main board are required).
3. Make sure that the host system (e.g. server with root complex chipset) is powered off.
4. Connect the evaluation board to the host system via the adapter card and cable provided by IDT.
5. Apply power to the host system and to the IDT board.

The EB-LOGAN-23 board is typically shipped with all jumpers and switches configured to their default settings which will satisfy the initial needs of the majority of the users. In most cases, the board does not require further modification or setup. However, please visit the IDT website and fill out the Technical Support Request form at <http://www.idt.com/?app=TechSupport> for other configurations.

PCI Express Mezzanine and Edge Adapters

The PCI Express lanes are broken out to four Mezzanine connectors on the EB-LOGAN-23 Evaluation Board. The adapter cards are used to convert Mezzanine connectors into PCI Express slot connector(s) or Internal mini SAS (iSAS) connectors or both. A Bifurcated Mezzanine Card has two mechanical x8 PCIe Slots (x4 electrically) while a Merged Mezzanine Card has single x8 PCIe Slot. Pictured in Figure 2.1.

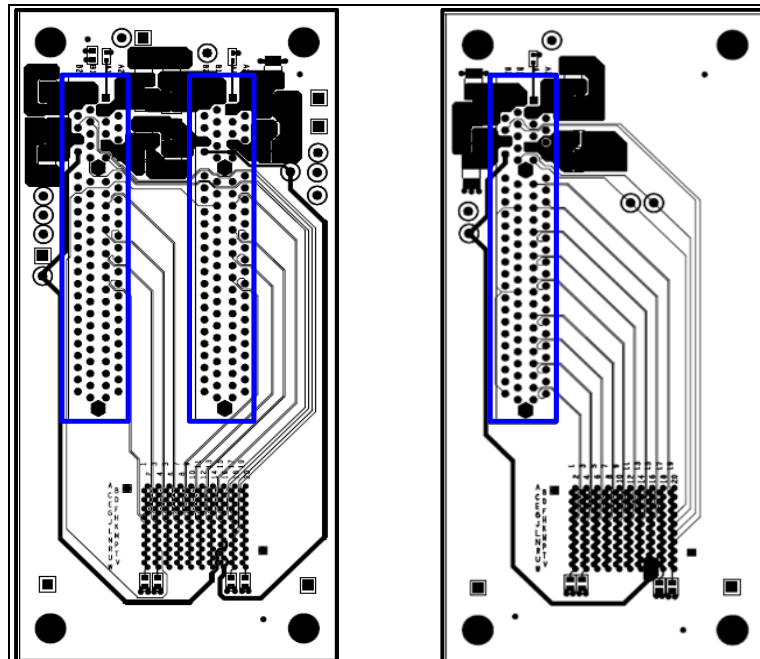

Figure 2.1 Bifurcated and Merged Mezzanine Cards

Notes

Pictured in Figure 2.2 is the mini-SAS Mezzanine card which consists of two iSAS and two SATA connectors. Each iSAS connector supports up to two PCI Express x4 width and the SATA connectors are used for clock and reset signals of each x4 or less stack/port. An iSAS-to-SATA breakout cable shown in Figure 2.3 is used connect from iSAS to edge adapter and/or 12PACK. An iSAS-to-iSAS cable shown in Figure 2.4 is used to connect from iSAS to x8 edge adapter.

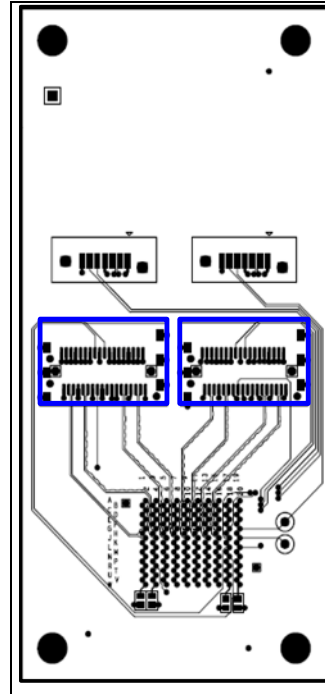

Figure 2.2 MiniSAS Mezzanine Adapter

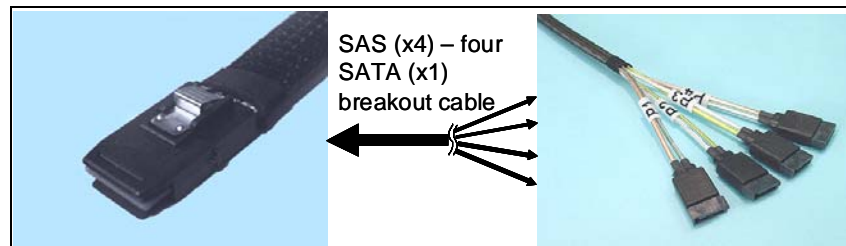

Figure 2.3 EB-LOGAN-23 iSAS-to-SATA Breakout Cable

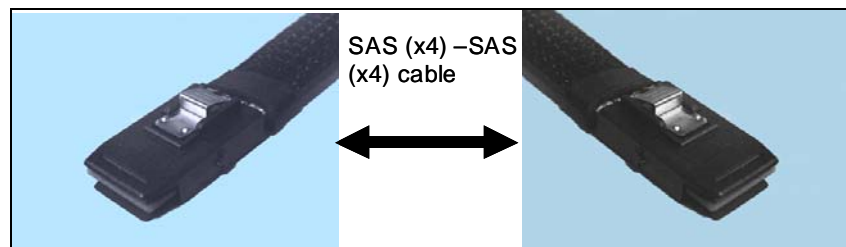

Figure 2.4 EB-LOGAN-23 iSAS-to-iSAS Cable

The PCI Express Edge to SATA Adapter, pictured in Figure 2.5 and Figure 2.6, can be inserted into any physical PCIe slot on a host system and in combination with mini-SAS Mezzanine Card, such as the one in Figure 2.2, to form a link between evaluation main board and the host system. There are 5 SATA connec-

Notes

tors: one connector is for clock and reset, and the remainder support one PCIe lane per SATA connector. The PCI Express Edge to SAS Adapter shown in Figure 2.6 is similar to the SATA adapter in that it supports up to a x8 width using two SAS cables. The edge adapters can be inserted into a mechanical x4/x8 or greater slot and supports x1, x2, x4, and x8 widths.

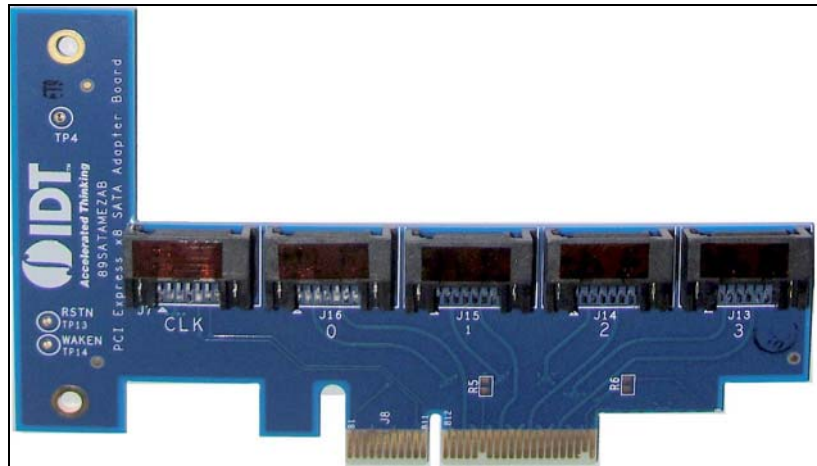

Figure 2.5 PCIe x4 Edge-to-SATA Adapter



Figure 2.6 PCIe x8 Edge-to-SAS Adapter

Hardware Description

The PES32NT24AG2 is a 32-lane, 24-port PCI Express® switch. It is a peripheral chip that performs PCI Express based switching with a feature set optimized for high performance applications such as servers and storage. It provides fan-out and switching functions between a PCI Express upstream port and downstream ports or peer-to-peer switching between downstream ports. Furthermore, up to eight ports can be configured as NTB ports for multi-root applications. The device offers additional features such as DMA and local port clocking support (a feature required for enabling multiple spread spectrum clocks in the system).

The EB-LOGAN-23 Main Board, shown in Figure 2.7, supports up to 6 PCI Express downstream ports and up to 23 ports when using two 12-PACK Boards.

Basic requirements for the board function are:

- Host system with a PCI Express root complex supporting x8 configuration through a PCI Express x8 slot. (If your host system does not offer a x8 slot, please contact ssdhelp@idt.com for alternative solutions.)
- - x1, x2, x4, or x8 PCI Express Endpoint Cards.

Notes

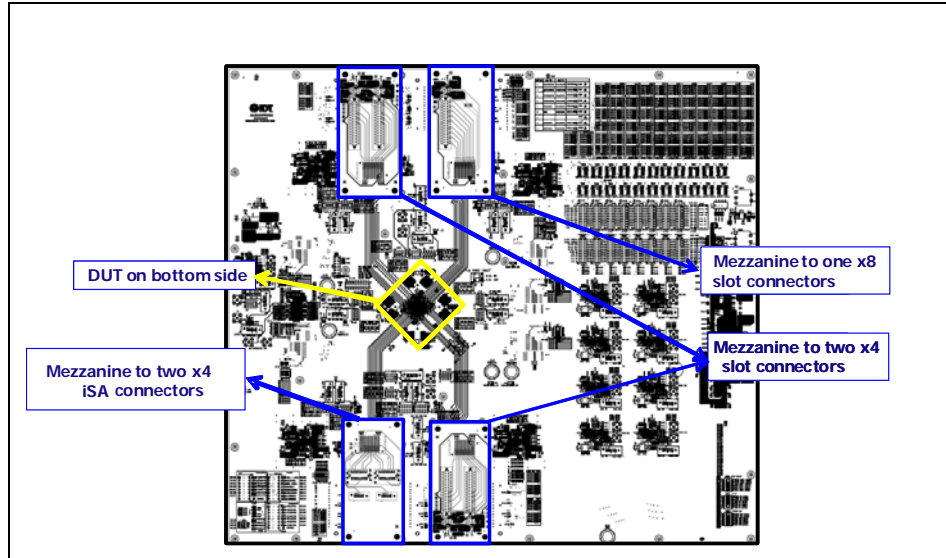

Figure 2.7 EB-LOGAN-23 Evaluation Main Board

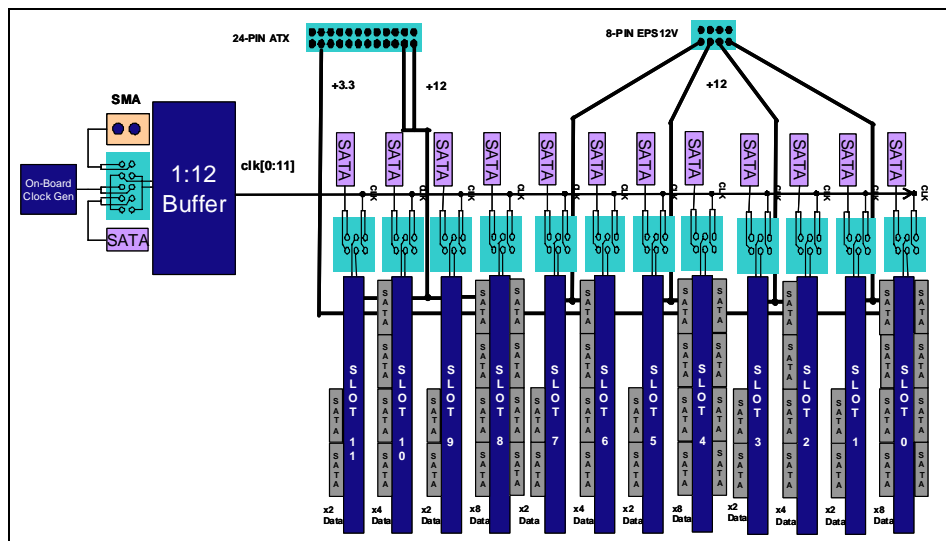

Figure 2.8 12-PACK PCIe Slots Breakout Board

Reference Clocks

Global Reference Input Clocks

The PES32NT24AG2 requires two differential reference clocks. The EB-LOGAN-23 derives these clocks from SMA connectors (J17/J20, J66/J67), clock buffer (U51) with on board clock generator (U49), SMA (J5/J7) or SATA (J8) connectors via jumpers (J6) as described in Table 2.2, or SATA connectors (J21, J22) as described in Table 2.1 and Figures 2.9 and 2.10. Both reference clocks are mandatory and must come from the same reference clock source. The switch will not function normally if only one clock is used.

Notes

Global Clock#	Jumper	Selection
GCLK0	J18	[1-3 / 2-4] SMA (J66/J67) [5-7 / 6-8] From Clock Buffer U51 (default) [7-9 / 8-10] SATA, J21
GCLK1	J19	[1-3 / 2-4] SMA (J17/J20) [5-7 / 6-8] From Clock Buffer U51 (default) [7-9 / 8-10] SATA, J22

Table 2.1 EB-LOGAN-23 Global Clock Select

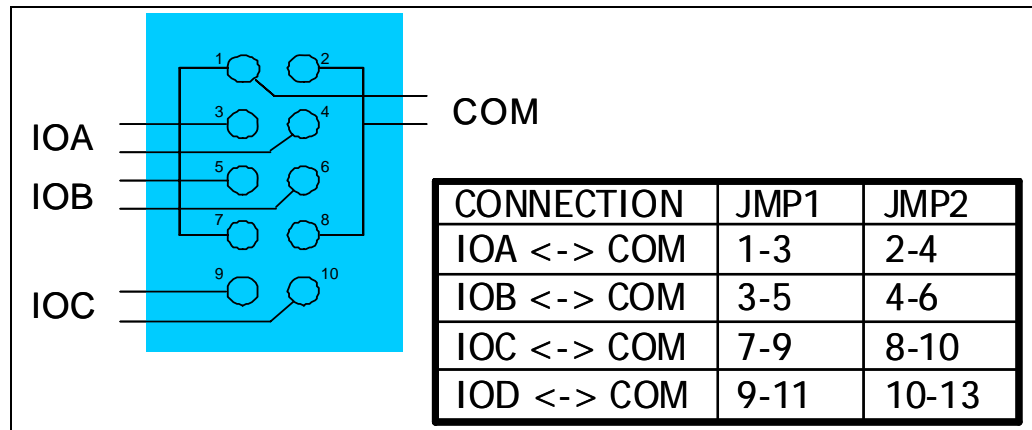

Figure 2.9 Differential Jumper Arrangement Example

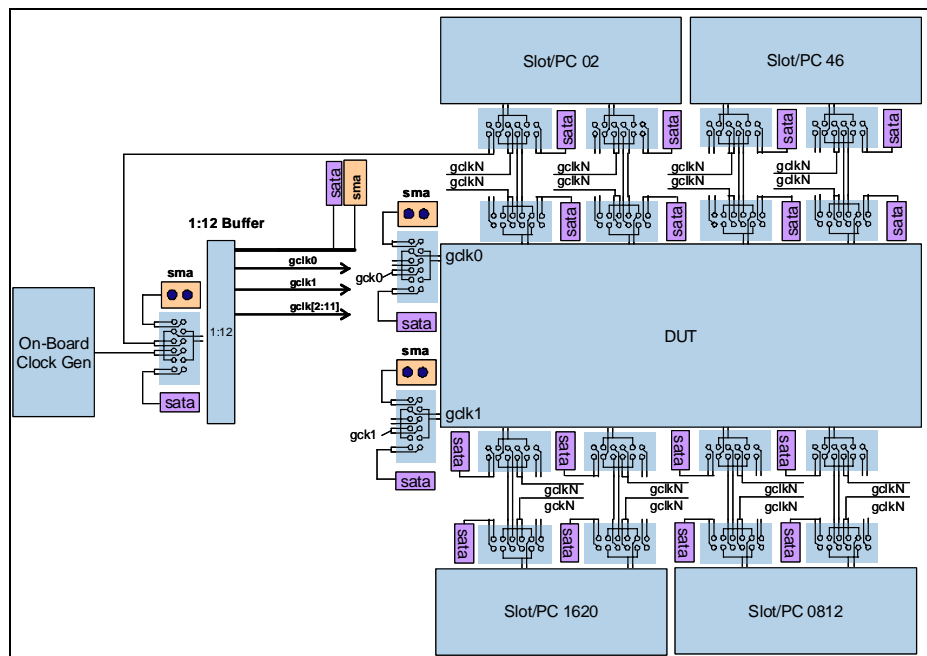

Figure 2.10 Reference Clock Configuration

By default, the clock buffer derives its clock from a common source. The common source can be the host system reference clock via a SATA connector, the onboard clock generator, or SMA connectors. See Table 2.2.

Notes

Jumper	Selection
J6	[1-3 / 2-4] SMA (J5/J7) [5-7 / 6-8] Onboard Clock Generator (U49) [7-9 / 8-10] SATA (J8) (default)

Table 2.2 Clock Buffer Input Sources

The frequency of the global reference clock input may be either 100 MHz or 125 MHz, as shown in Table 2.3, and is selected by the Clock Frequency Select (GCLKFEL) pin.

Global Clock Frequency Switch - SW10[2]	
SW10[2]	Clock Frequency
ON	100 MHz (Default)
OFF	125 MHz

Table 2.3 Global Reference Input Clock Frequency Select

The source for the onboard clock is the ICS841484 clock generator device (U49) connected to a 25MHz oscillator (X1). When using the onboard clock generator, the output frequency can be selected using ICS_FS (SW10, bit 1). The default setting is ON. See Table 2.4.

Onboard Clock Frequency Switch - SW10[1]	
SW10[1]	Clock Frequency
ON	100 MHz (Default)
OFF	125 MHz

Table 2.4 Onboard Clock Generator Frequency Select

The output of the onboard clock generator is accessible through SMA or SATA connectors. See Table 2.5. This can be used to connect a scope for probing or capturing purposes and cannot be used to drive the clock from an external source.

Onboard Reference Clock Output (Differential)	
TP119	Positive Reference Clock (SMA)
TP120	Negative Reference Clock (SMA)
J121	Differential Reference Clock (SATA)

Table 2.5 Onboard Reference Clock Generator Access Points

Local Port Input Clocks

Associated with some ports is a local port reference clock input (PxCLK). Depending on the port clocking mode, a differential reference clock can be driven into the device on the corresponding PxCLKP and PxCLKN pins. The frequency of a port reference clock input MUST always at 100 MHz. Table 2.6 lists the possible sources for the port reference clock input, and Table 2.9 lists the possible sources for the slot clock input. Additional information on port clocking usage and configuration can be found in the Device User Manuals and in IDT's Application Note AN-715.

Notes

Port #	Header	Selection
0	J9	[1-3 / 2-4] Onboard Clock Generator (U116) [3-5 / 4-6] SATA (J58)
2	J10	[1-3 / 2-4] Onboard Clock Generator (U122) [3-5 / 4-6] SATA (J59)
4	J11	[1-3 / 2-4] Onboard Clock Generator (U123) [3-5 / 4-6] SATA (J60)
6	J12	[1-3 / 2-4] Onboard Clock Generator (U117) [3-5 / 4-6] SATA (J61)
12	J14	[1-3 / 2-4] Onboard Clock Generator (U119) [3-5 / 4-6] SATA (J63)
20	J16	[1-3 / 2-4] Onboard Clock Generator (U121) [3-5 / 4-6] SATA (J65)

Table 2.6 EB-LOGAN-23 Port (0, 2, 4, 6, 12, 20) Clock Select

Local port clock sources for ports 8 and 16 are selected by DIP switch (S17 and S19) via a clock mux/buffer. See Tables 2.7 and 2.8.

Port 8 Clock Source Select - S19[1]	
S19[1]	Clock Source
OFF	SATA J62
ON	Port 8 Clock Generator (U118)

Table 2.7 EB-LOGAN-23 Port 8 Clock Source Select

Port 16 Clock Source Select - S17[1]	
S17[1]	Clock Source
OFF	SATA J64
ON	Port 16 Clock Generator (U120)

Table 2.8 EB-LOGAN-23 Port 16 Clock Source Select

Notes

Slot #	Jumper	Selection
0	J23	[1-3 / 2-4] Onboard Clock Generator (U115) [3-5 / 4-6] Clock Buffer (U51) [7-9 / 8-10] P08CLK Clock Mux (U18) [9-11 / 10-12] SATA (J27)
2	J24	[1-3 / 2-4] Onboard Clock Generator (U122) [3-5 / 4-6] Clock Buffer (U51) [7-9 / 8-10] P08CLK Clock Mux (U18) [9-11 / 10-12] SATA (J28)
4	J25	[1-3 / 2-4] Onboard Clock Generator (U123) [3-5 / 4-6] Clock Buffer (U51) [7-9 / 8-10] P08CLK Clock Mux (U18) [9-11 / 10-12] SATA (J29)
6	J26	[1-3 / 2-4] Onboard Clock Generator (U117) [3-5 / 4-6] Clock Buffer (U51) [7-9 / 8-10] P16CLK Clock Mux (U16) [9-11 / 10-12] SATA (J30)
8	J31	[1-3 / 2-4] Onboard Clock Generator (U118) [3-5 / 4-6] Clock Buffer (U51) [7-9 / 8-10] P16CLK Clock Mux (U16) [9-11 / 10-12] SATA (J31)
12	J32	[1-3 / 2-4] Onboard Clock Generator (U119) [3-5 / 4-6] Clock Buffer (U51) [7-9 / 8-10] P16CLK Clock Mux (U16) [9-11 / 10-12] SATA (J32)
16	J33	[1-3 / 2-4] Onboard Clock Generator (U120) [3-5 / 4-6] Clock Buffer (U51) [7-9 / 8-10] P08CLK Clock Mux (U18) [9-11 / 10-12] SATA (J33)
20	J34	[1-3 / 2-4] Onboard Clock Generator (U121) [3-5 / 4-6] Clock Buffer (U51) [7-9 / 8-10] P16CLK Clock Mux (U16) [9-11 / 10-12] SATA (J34)

Table 2.9 EB-LOGAN-23 Slot Clock Select

CLKMODE Selection

All ports in the PES32NT24AG2 device (upstream and downstream) use global clocked mode by default. The port clocking mode of a port is determined by the state of the CLKMODE[1:0] pins in the boot configuration vector as shown in Table 2.10. This field determines the initial value of the Slot Clock Configuration (SCLK) field in each port's PCI Express Link Status (PCIELSTS) register. The SCLK field controls the advertisement of whether or not the port uses the same reference clock source as the link partner. A one in the SCLK field indicates that the port and its link partner use the same reference clock source. This is defined as Common Clock Configuration by the PCI Express Base Specification. A zero in the SCLK field indicates that the port and its link partner do not use the same reference clock source.

Notes

SW10[8] CLKMODE[0]	SW10[7] CLKMODE[1]	Port 0 SCLK	Port[15:1] SCLK
ON	ON	0	0
OFF	ON	1	0
ON	OFF	0	1
OFF	OFF	1	1

Table 2.10 CLKMODE Selection for the PES32NT24AG2

Power Sources

Power for the PES32NT24AG2 and all downstream ports is generated from a 12V supply via an external power connector. See Table 2.11. A 12V to 3.3V DC-DC converter is used to provide power to five switching regulators to generate $V_{DD}CORE$, $V_{DD}PEA$, $V_{DD}PETA$, $V_{DD}PEHA$, and $V_{DD}IO$ voltages. The 3.3V from the DC-DC converter will be used to power the clock buffers and circuitries.

The external power supply connectors are 24-pin (J69) and 8-pin (J68) molex connectors as described in Tables 2.11 and 2.12. The +12V3 is used to power the PES32NT24AG2 and downstream slots 0, 2, 16, and 20. The +12V2 is used to power downstream slots 4, 6, 8, and 12.

Pin	Signal	Pin	Signal
1	+3.3V	13	+3.3V
2	+3.3V	14	-12V
3	GND	15	GND
4	+5V	16	PS_ON
5	GND	17	GND
6	+5V	18	GND
7	GND	19	GND
8	PWR_OK	20	NC
9	5VSB	21	+5V
10	+12V3	22	+5V
11	+12V3	23	+5V
12	+3.3V	24	GND

Table 2.11 EPS12V 24-pin Power Connector - J69

Pin	Signal	Pin	Signal
1	GND	5	+12V1
2	GND	6	+12V1
3	GND	7	+12V2
4	GND	8	+12V2

Table 2.12 EPS12V 8-Pin Connector - J68

Notes

The power switch located at S1 can be used to control the supply power from the external power supply connector. Add a shunt to W27 to enable power on switch.

PCI Express Analog Power Voltage Regulator

A voltage regulator (U65) provides a 2.5V PCI Express analog power voltage (shown as VDDPEHA) to the PES32NT24AG2.

PCI Express Digital Power Voltage Converter

A separate voltage regulator (U62) provides a 1.0V PCI Express analog power voltage (shown as VDDPEA) to the PES32NT24AG2.

PCI Express Transmitter Analog Voltage Converter

A separate voltage regulator (U68) provides a 1.0V PCI Express transmitter analog voltage (shown as VDDPETA) to the PES32NT24AG2.

Core Logic Voltage Converter

A separate voltage regulator (U59) provides the 1.0V core voltage (VDDCORE) to the PES32NT24AG2.

3.3V I/O Voltage Regulator

A separate voltage regulator (U56) provides the 3.3V I/O voltage (VDDIO) to the PES32NT24AG2.

Power-up Sequence for PES32NT24AG2

During power supply ramp-up, VDDCORE must remain at least 1.0V below VDDIO at all times. There are no other power-up sequence requirements for the various operating supply voltages.

Heatsink Requirement

The EB-LOGAN-23 evaluation board utilizes a heatsink with integrated fan. All initial shipments of the board are made with the heatsink whether or not one is truly required. There may be low link usage applications within which the heatsink may, in fact, not be required.

Reset

The PES32NT24AG2 supports two types of reset mechanisms as described in the PCI Express specification:

- Fundamental Reset: This is a system-generated reset that propagates along the PCI Express tree through a single side-band signal PERST# which is connected to the Root Complex, the PES32NT24AG2, and the endpoints.
- Hot Reset: This is an In-band Reset, communicated downstream via a link from one device to another. Hot Reset may be initiated by software. This is further discussed in the PES32NT24xG2 User Manual. The EB-LOGAN-23 evaluation board provides seamless support for Hot Reset.

Fundamental Reset

There are two types of Fundamental Resets which may occur on the EB-LOGAN-23 evaluation board:

- Cold Reset: During initial power-on, the onboard voltage monitor (TLC7733D) will assert the PCI Express Reset (PERSTN) input pin of the PES32NT24AG2.
- Warm Reset: This is triggered by hardware while the device is powered on. Warm Reset can be initiated by two methods:
 - Pressing a push-button switch (S3) located on EB-LOGAN-23 board
 - The host system board IO Controller Hub asserting PERST# signal, which propagates through the PCIe upstream edge connector of the EB-LOGAN-23.

Both events cause the onboard voltage monitor (TLC7733D) to assert the PCI Express Reset (PERSTN) input of the PES32NT24AG2 while power is on.

Notes

Downstream Reset

Single Partition Mode without Hot Plug:

When the evaluation board initially powers on, it assumes the following:

- ◆ The switch is configured in single partition mode.
- ◆ Slot 0 is the root port and controls the downstream port resets.
- ◆ Ports 1-23 are downstream ports.
- ◆ Hot Plug is disabled.

The following behavior should be observed:

- ◆ The resets to slots 1-23 should initially be asserted and remain this way until after the fundamental reset is initially de-asserted.
- ◆ The assertion of slot 0 reset should propagate to slots 1-23.

Stack Configuration

The PES32NT24AG2 contains four stack blocks labeled Stack 0, Stack 1, Stack 2, and Stack 3. Stacks 0 and 1 have four x2 ports each, and stacks 2 and 3 have eight x1 ports each. This provides a total of 24 ports in the device labeled port 0 through port 23. Table 2.13 lists the ports associated with each stack.

Stack	Ports Associated with the Stack
Stack 0	0, 1, 2, 3
Stack 1	4, 5, 6, 7
Stack 2	8, 9, 10, 11, 12, 13, 14, 15
Stack 3	16, 17, 18, 19, 20, 21, 22, 23

Table 2.13 Ports in Each Stack

Boot Configuration Vector

A boot configuration vector consisting of the signals listed in Table 2.14 is sampled by the PES32NT24AG2 during a fundamental reset (while PERSTN is active). The boot configuration vector defines the essential parameters for switch operation and is set using DIP switches S5, SW8, SW9, and SW10 as defined in Table 2.15.

Signal	Description
GCLKFSEL	Global Clock Frequency Select. This pin specifies the frequency of the GCLKP and GCLKN signals. Default: low
CLKMODE[1:0]	Clock Mode. These pins specify the clocking mode used by switch ports. See Table 2.10 for a definition of the encoding of these signals. The value of these signals may be overridden by modifying the Port Clocking Mode (PCLKMODE) register.
RSTHALT	Reset Halt. When this pin is asserted during a switch fundamental reset sequence, the switch remains in a quasi-reset state with the Master and Slave SMBuses active. This allows software to read and write registers internal to the device before normal device operation begins. The device exits the quasi-reset state when the RSTHALT bit is cleared in the SWCTL register by an SMBus master. Refer to section Switch Fundamental Reset on page 3-2 for further details. Default: low
SSMBADDR[2:1]	Slave SMBus Address. SMBus address of the switch on the slave SMBus. Default: 0x3

Table 2.14 Boot Configuration Vector Signals (Part 1 of 2)

Notes

Signal	Description
SWMODE[3:0]	Switch Mode. These pins specify the switch operating mode.
STK0CFG[1:0]	Stack 0 Configuration. These pins select the configuration of stack 0 during a switch fundamental reset.
STK1CFG[1:0]	Stack 1 Configuration. These pins select the configuration of stack 1 during a switch fundamental reset.
STK2CFG[4:0]	Stack 2 Configuration. These pins select the configuration of stack 2 during a switch fundamental reset.
STK3CFG[4:0]	Stack 3 Configuration. These pins select the configuration of stack 3 during a switch fundamental reset.

Table 2.14 Boot Configuration Vector Signals (Part 2 of 2)

Location	Signal	Default
SW10[2]	GCLKFSEL	ON
SW10[4]	RSTHALT	ON
SW10[5]	SSMBADDR[2]	OFF
SW10[6]	SSMBADDR[1]	OFF

Table 2.15 Boot Configuration Vector Switch SW10

SMBus Interfaces

The System Management Bus (SMBus) is a two-wire interface through which various system component chips can communicate. It is based on the principles of operation of I²C. Implementation of the SMBus signals in the PCI Express connector is optional and may not be present on the host system. The SMBus interface consists of an SMBus clock pin and an SMBus data pin.

The PES32NT24AG2 contains two SMBus interfaces: a slave SMBus interface and a master SMBus interface. The slave SMBus interface allows a SMBus Master device full access to all software-visible registers. The Master SMBus interface provides a connection to the external serial EEPROM used for initialization and the I/O expanders used for hot-plug signals.

SMBus Slave Interface

On the PES32NT24AG2 board, the slave SMBus interface is accessible through a 4-pin header as described in Table 2.16.

Slave SMBus Interface Connector J71	
Pin	Signal
1	SDA
2	GND
3	SCL
4	NC

Table 2.16 Slave SMBus Interface Connector

Notes

For a fixed address, the SMBus address of the PES32NT24AG2 slave interface is **0b1110111** by default and is configurable using DIP Switches SW10[5] and SW10[6] as described in Table 2.17.

Slave Interface Address Configuration	
Address Bit	Signal
1	SSMBUSADDR[1]
2	SSMBUSADDR[2]
3	1
4	0
5	1
6	1
7	1

Table 2.17 SMBus Slave Interface Address Configuration

The slave SMBus interface responds to the following SMBus transactions initiated by an SMBus master. Initiation of any SMBus transaction other than those listed above produces undefined results. See the SMBus 2.0 specification for a detailed description of the following transactions:

- Byte and Word Write/Read
- Block Write/Read

SMBus Master Interface

Connected to the master SMBus interface are twenty-two 16-bit I/O Expanders (MAX7311AUG) and a serial EEPROM, U77 (24LC512). The I/O Expanders are used as the interface for the onboard hot-plug controllers (MIC2591B). The lower three bits of the bus address for the I/O Expander 0 through 20 are fixed through the stuffing resistor as 0x20, 0x22, 0x24, 0x26, 0x28, 0x2A, 0x2C, 0x2E, 0x50, 0x52, 0x54, 0x56, 0x58, 0x5A, 0x5C, 0x5E, 0xB0, 0xA2, 0xA4, 0xA6, 0xA8, and 0xAA, respectively.

Note: Hot-plug is not implemented when the PES32NT24AG2 is installed.

The seven bits address for the selected EEPROM device is fixed at **0b1010_000** by default.

JTAG Header

The PES32NT24AG2 provides a JTAG connector J73 for access to the PES32NT24AG2 JTAG interface. The connector is a 2.54 x 2.54 mm pitch male 14-pin connector. Refer to Table 2.18 for the JTAG Connector J73 pin out.

JTAG Connector J5					
Pin	Signal	Direction	Pin	Signal	Direction
1	/TRST - Test reset	Input	2	GND	—
3	TDI - Test data	Input	4	GND	—
5	TDO - Test data	Output	6	GND	—
7	TMS - Test mode select	Input	8	GND	—
9	TCK - Test clock	Input	10	GND	—
11	3.3V		12	N/C	—
13	GND	—	14	3.3V	

Table 2.18 JTAG Connector Pin Out

Notes

Miscellaneous Jumpers, Headers

Miscellaneous Jumpers, Headers			
Ref. Designator	Type	Default	Description
W1	Header	1-2 Shunted	1-2: GPIO 8 to DS414 when ALT1 (Default) 2-3: GPIO 8 to IO Expander Interrupt when ALT0
W5	Header	Shunted	2-3: Slot 0, 3.3Vaux source from Direct Power (Default) 1-2: Slot 0, 3.3Vaux source from hot-plug controller
W6	Header	2-3 Shunted	2-3: Slot 2, 3.3Vaux source from Direct Power (Default) 1-2: Slot 2, 3.3Vaux source from hot-plug controller
W11	Header	2-3 Shunted	2-3: Slot 4, 3.3Vaux source from Direct Power (Default) 1-2: Slot 4, 3.3Vaux source from hot-plug controller
W12	Header	2-3 Shunted	2-3: Slot 6, 3.3Vaux source from Direct Power (Default) 1-2: Slot 6, 3.3Vaux source from hot-plug controller
W17	Header	2-3 Shunted	2-3: Slot 8, 3.3Vaux source from Direct Power (Default) 1-2: Slot 8, 3.3Vaux source from hot-plug controller
W18	Header	2-3 Shunted	2-3: Slot 12, 3.3Vaux source from Direct Power (Default) 1-2: Slot 12, 3.3Vaux source from hot-plug controller
W23	Header	2-3 Shunted	2-3: Slot 16, 3.3Vaux source from Direct Power (Default) 1-2: Slot 16, 3.3Vaux source from hot-plug controller
W24	Header	2-3 Shunted	2-3: Slot 20, 3.3Vaux source from Direct Power (Default) 1-2: Slot 20, 3.3Vaux source from hot-plug controller
W4	Header	2-3 Shunted	2-3: Slot 0, +12V source from Direct Power (Default) 1-2: Slot 0, +12V source from hot-plug controller
W8	Header	2-3 Shunted	2-3: Slot 2, +12V source base on W57(Default) 1-2: Slot 2, +12V source from hot-plug controller
W10	Header	2-3 Shunted	2-3: Slot 4, +12V source from Direct Power (Default) 1-2: Slot 4, +12V source from hot-plug controller
W14	Header	2-3 Shunted	2-3: Slot 6, +12V source from Direct Power (Default) 1-2: Slot 6, +12V source from hot-plug controller
W16	Header	2-3 Shunted	2-3: Slot 8, +12V source from Direct Power (Default) 1-2: Slot 8, +12V source from hot-plug controller
W20	Header	2-3 Shunted	2-3: Slot 12, +12V source from Direct Power (Default) 1-2: Slot 12, +12V source from hot-plug controller
W22	Header	2-3 Shunted	2-3: Slot 16, +12V source from Direct Power (Default) 1-2: Slot 16, +12V source from hot-plug controller
W26	Header	2-3 Shunted	2-3: Slot 20, +12V source from Direct Power (Default) 1-2: Slot 20, +12V source from hot-plug controller
W3	Header	2-3 Shunted	2-3: Slot 0, +3.3V source from Direct Power (Default) 1-2: Slot 0, +3.3V source from hot-plug controller
W7	Header	2-3 Shunted	2-3: Slot 2, +3.3V source from Direct Power (Default) 1-2: Slot 2, +3.3V source from hot-plug controller
W9	Header	2-3 Shunted	2-3: Slot 4, +3.3V source from Direct Power (Default) 1-2: Slot 4, +3.3V source from hot-plug controller

Table 2.19 Miscellaneous Jumpers, Headers (Part 1 of 2)

Notes

Miscellaneous Jumpers, Headers			
Ref. Designator	Type	Default	Description
W13	Header	2-3 Shunted	2-3: Slot 6, +3.3V source from Direct Power (Default) 1-2: Slot 6, +3.3V source from hot-plug controller
W15	Header	2-3 Shunted	2-3: Slot 8, +3.3V source from Direct Power (Default) 1-2: Slot 8, +3.3V source from hot-plug controller
W19	Header	2-3 Shunted	2-3: Slot 12, +3.3V source from Direct Power (Default) 1-2: Slot 12, +3.3V source from hot-plug controller
W21	Header	2-3 Shunted	2-3: Slot 16, +3.3V source from Direct Power (Default) 1-2: Slot 16, +3.3V source from hot-plug controller
W25	Header	2-3 Shunted	2-3: Slot 20, +3.3V source from Direct Power (Default) 1-2: Slot 20, +3.3V source from hot-plug controller

Table 2.19 Miscellaneous Jumpers, Headers (Part 2 of 2)

LEDs

There are many LED indicators on the EB-LOGAN-23 which convey status feedback. A description of each is provided in Table 2.20.

Location	Color	Definition
DS1	Green	Board Power Indicator (5V)
DS2	Green	Board Power Indicator (3.3V)
DS4	Green	VDDIO Indicator (3.3V)
DS158	Orange	Port23: Attention Push Button Input
DS159	Orange	Port22: Attention Push Button Input
DS160	Orange	Port21: Attention Push Button Input
DS161	Orange	Port20: Attention Push Button Input
DS162	Orange	Port19: Attention Push Button Input
DS163	Orange	Port18: Attention Push Button Input
DS164	Orange	Port17: Attention Push Button Input
DS165	Orange	Port16: Attention Push Button Input
DS166	Orange	Port15: Attention Push Button Input
DS167	Orange	Port14: Attention Push Button Input
DS168	Orange	Port13: Attention Push Button Input
DS169	Orange	Port12: Attention Push Button Input
DS170	Orange	Port11: Attention Push Button Input
DS171	Orange	Port10: Attention Push Button Input
DS172	Orange	Port9: Attention Push Button Input
DS173	Orange	Port8: Attention Push Button Input

Table 2.20 LED Indicators (Part 1 of 8)

Notes

Location	Color	Definition
DS174	Orange	Port7: Attention Push Button Input
DS175	Orange	Port6: Attention Push Button Input
DS176	Orange	Port5: Attention Push Button Input
DS177	Orange	Port4: Attention Push Button Input
DS178	Orange	Port3: Attention Push Button Input
DS179	Orange	Port2: Attention Push Button Input
DS180	Orange	Port1: Attention Push Button Input
DS181	Orange	Port0: Attention Push Button Input
DS182	Yellow	Port23: Presence Detect Input
DS183	Yellow	Port22: Presence Detect Input
DS184	Yellow	Port21: Presence Detect Input
DS185	Yellow	Port20: Presence Detect Input
DS186	Yellow	Port19: Presence Detect Input
DS187	Yellow	Port18: Presence Detect Input
DS188	Yellow	Port17: Presence Detect Input
DS189	Yellow	Port16: Presence Detect Input
DS190	Yellow	Port15: Presence Detect Input
DS191	Yellow	Port14: Presence Detect Input
DS192	Yellow	Port13: Presence Detect Input
DS193	Yellow	Port12: Presence Detect Input
DS194	Yellow	Port11: Presence Detect Input
DS195	Yellow	Port10: Presence Detect Input
DS196	Yellow	Port9: Presence Detect Input
DS197	Yellow	Port8: Presence Detect Input
DS198	Yellow	Port7: Presence Detect Input
DS199	Yellow	Port6: Presence Detect Input
DS200	Yellow	Port5: Presence Detect Input
DS201	Yellow	Port4: Presence Detect Input
DS202	Yellow	Port3: Presence Detect Input
DS203	Yellow	Port2: Presence Detect Input
DS204	Yellow	Port1: Presence Detect Input
DS205	Yellow	Port0: Presence Detect Input
DS5	Red	Port23: Power Fault Input
DS6	Red	Port22: Power Fault Input
DS7	Red	Port21: Power Fault Input
DS8	Red	Port20: Power Fault Input
DS9	Red	Port19: Power Fault Input

Table 2.20 LED Indicators (Part 2 of 8)

Notes

Location	Color	Definition
DS10	Red	Port18: Power Fault Input
DS11	Red	Port17: Power Fault Input
DS12	Red	Port16: Power Fault Input
DS13	Red	Port15: Power Fault Input
DS14	Red	Port14: Power Fault Input
DS15	Red	Port13: Power Fault Input
DS16	Red	Port12: Power Fault Input
DS17	Red	Port11: Power Fault Input
DS18	Red	Port10: Power Fault Input
DS19	Red	Port9: Power Fault Input
DS20	Red	Port8: Power Fault Input
DS21	Red	Port7: Power Fault Input
DS22	Red	Port6: Power Fault Input
DS23	Red	Port5: Power Fault Input
DS24	Red	Port4: Power Fault Input
DS25	Red	Port3: Power Fault Input
DS26	Red	Port2: Power Fault Input
DS27	Red	Port1: Power Fault Input
DS28	Red	Port0: Power Fault Input
DS29	Green	Port23: Power Good Input
DS30	Green	Port22: Power Good Input
DS31	Green	Port21: Power Good Input
DS32	Green	Port20: Power Good Input
DS33	Green	Port19: Power Good Input
DS34	Green	Port18: Power Good Input
DS35	Green	Port17: Power Good Input
DS36	Green	Port16: Power Good Input
DS37	Green	Port15: Power Good Input
DS38	Green	Port14: Power Good Input
DS39	Green	Port13: Power Good Input
DS40	Green	Port12: Power Good Input
DS41	Green	Port11: Power Good Input
DS42	Green	Port10: Power Good Input
DS43	Green	Port9: Power Good Input
DS44	Green	Port8: Power Good Input
DS45	Green	Port7: Power Good Input
DS46	Green	Port6: Power Good Input

Table 2.20 LED Indicators (Part 3 of 8)

Notes

Location	Color	Definition
DS47	Green	Port5: Power Good Input
DS48	Green	Port4: Power Good Input
DS49	Green	Port3: Power Good Input
DS50	Green	Port2: Power Good Input
DS51	Green	Port1: Power Good Input
DS52	Green	Port0: Power Good Input
DS206	Orange	Port23: Attention Indicator Output
DS207	Orange	Port22: Attention Indicator Output
DS208	Orange	Port21: Attention Indicator Output
DS209	Orange	Port20: Attention Indicator Output
DS210	Orange	Port19: Attention Indicator Output
DS211	Orange	Port18: Attention Indicator Output
DS212	Orange	Port17: Attention Indicator Output
DS213	Orange	Port16: Attention Indicator Output
DS214	Orange	Port15: Attention Indicator Output
DS215	Orange	Port14: Attention Indicator Output
DS216	Orange	Port13: Attention Indicator Output
DS217	Orange	Port12: Attention Indicator Output
DS218	Orange	Port11: Attention Indicator Output
DS219	Orange	Port10: Attention Indicator Output
DS220	Orange	Port9: Attention Indicator Output
DS221	Orange	Port8: Attention Indicator Output
DS222	Orange	Port7: Attention Indicator Output
DS223	Orange	Port6: Attention Indicator Output
DS224	Orange	Port5: Attention Indicator Output
DS225	Orange	Port4: Attention Indicator Output
DS226	Orange	Port3: Attention Indicator Output
DS227	Orange	Port2: Attention Indicator Output
DS228	Orange	Port1: Attention Indicator Output
DS229	Orange	Port0: Attention Indicator Output
DS230	Green	Port23: Power Indicator Output
DS231	Green	Port22: Power Indicator Output
DS232	Green	Port21: Power Indicator Output
DS233	Green	Port20: Power Indicator Output
DS234	Green	Port19: Power Indicator Output
DS235	Green	Port18: Power Indicator Output
DS236	Green	Port17: Power Indicator Output

Table 2.20 LED Indicators (Part 4 of 8)

Notes

Location	Color	Definition
DS237	Green	Port16: Power Indicator Output
DS238	Green	Port15: Power Indicator Output
DS239	Green	Port14: Power Indicator Output
DS240	Green	Port13: Power Indicator Output
DS241	Green	Port12: Power Indicator Output
DS242	Green	Port11: Power Indicator Output
DS243	Green	Port10: Power Indicator Output
DS244	Green	Port9: Power Indicator Output
DS245	Green	Port8: Power Indicator Output
DS246	Green	Port7: Power Indicator Output
DS247	Green	Port6: Power Indicator Output
DS248	Green	Port5: Power Indicator Output
DS249	Green	Port4: Power Indicator Output
DS250	Green	Port3: Power Indicator Output
DS251	Green	Port2: Power Indicator Output
DS252	Green	Port1: Power Indicator Output
DS253	Green	Port0: Power Indicator Output
DS53	Green	Port23: Power Enable Output
DS54	Green	Port22: Power Enable Output
DS55	Green	Port21: Power Enable Output
DS56	Green	Port20: Power Enable Output
DS57	Green	Port19: Power Enable Output
DS58	Green	Port18: Power Enable Output
DS59	Green	Port17: Power Enable Output
DS60	Green	Port16: Power Enable Output
DS61	Green	Port15: Power Enable Output
DS62	Green	Port14: Power Enable Output
DS63	Green	Port13: Power Enable Output
DS64	Green	Port12: Power Enable Output
DS65	Green	Port11: Power Enable Output
DS66	Green	Port10: Power Enable Output
DS67	Green	Port9: Power Enable Output
DS68	Green	Port8: Power Enable Output
DS69	Green	Port7: Power Enable Output
DS70	Green	Port6: Power Enable Output
DS71	Green	Port5: Power Enable Output
DS72	Green	Port4: Power Enable Output

Table 2.20 LED Indicators (Part 5 of 8)

Notes

Location	Color	Definition
DS73	Green	Port3: Power Enable Output
DS74	Green	Port2: Power Enable Output
DS75	Green	Port1: Power Enable Output
DS76	Green	Port0: Power Enable Output
DS77	Red	Slot 23 Reset Output
DS78	Red	Slot 22 Reset Output
DS79	Red	Slot 21 Reset Output
DS80	Red	Slot 20 Reset Output
DS81	Red	Slot 19 Reset Output
DS82	Red	Slot 18 Reset Output
DS83	Red	Slot 17 Reset Output
DS84	Red	Slot 16 Reset Output
DS85	Red	Slot 15 Reset Output
DS86	Red	Slot 14 Reset Output
DS87	Red	Slot 13 Reset Output
DS88	Red	Slot 12 Reset Output
DS89	Red	Slot 11 Reset Output
DS90	Red	Slot 10 Reset Output
DS91	Red	Slot 9 Reset Output
DS92	Red	Slot 8 Reset Output
DS93	Red	Slot 7 Reset Output
DS94	Red	Slot 6 Reset Output
DS95	Red	Slot 5 Reset Output
DS96	Red	Slot 4 Reset Output
DS97	Red	Slot 3 Reset Output
DS98	Red	Slot 2 Reset Output
DS99	Red	Slot 1 Reset Output
DS100	Red	Slot 0 Reset Output
DS326	Red	Partition 7 Fundamental Reset Input
DS327	Red	Partition 6 Fundamental Reset Input
DS328	Red	Partition 5 Fundamental Reset Input
DS329	Red	Partition 4 Fundamental Reset Input
DS330	Red	Partition 3 Fundamental Reset Input
DS331	Red	Partition 2 Fundamental Reset Input
DS332	Red	Partition 1 Fundamental Reset Input
DS333	Red	Partition 0 Fundamental Reset Input
DS415	Red	Slot 20 Reset Header (J131)

Table 2.20 LED Indicators (Part 6 of 8)

Notes

Location	Color	Definition
DS416	Red	Slot 16 Reset Header (J130)
DS417	Red	Slot 12 Reset Header (J129)
DS418	Red	Slot 4 Reset Header (J125)
DS419	Red	Slot 6 Reset Header (J128)
DS420	Red	Slot 4 Reset Header (J127)
DS421	Red	Slot 2 Reset Header (J126)
DS422	Red	Slot 0 Reset Header (J125)
DS334	Green	Port23: Link Up Status Output
DS335	Green	Port22: Link Up Status Output
DS336	Green	Port21: Link Up Status Output
DS337	Green	Port20: Link Up Status Output
DS338	Green	Port19: Link Up Status Output
DS339	Green	Port18: Link Up Status Output
DS340	Green	Port17: Link Up Status Output
DS341	Green	Port16: Link Up Status Output
DS342	Green	Port15: Link Up Status Output
DS343	Green	Port14: Link Up Status Output
DS344	Green	Port13: Link Up Status Output
DS345	Green	Port12: Link Up Status Output
DS346	Green	Port11: Link Up Status Output
DS347	Green	Port10: Link Up Status Output
DS348	Green	Port9: Link Up Status Output
DS349	Green	Port8: Link Up Status Output
DS350	Green	Port7: Link Up Status Output
DS351	Green	Port6: Link Up Status Output
DS352	Green	Port5: Link Up Status Output
DS353	Green	Port4: Link Up Status Output
DS354	Green	Port3: Link Up Status Output
DS355	Green	Port2: Link Up Status Output
DS356	Green	Port1: Link Up Status Output
DS357	Green	Port0: Link Up Status Output
DS358	Blue	Port23: Link Activity Status Output
DS359	Blue	Port22: Link Activity Status Output
DS360	Blue	Port21: Link Activity Status Output
DS361	Blue	Port20: Link Activity Status Output
DS362	Blue	Port19: Link Activity Status Output
DS363	Blue	Port18: Link Activity Status Output

Table 2.20 LED Indicators (Part 7 of 8)

Notes

Location	Color	Definition
DS364	Blue	Port17: Link Activity Status Output
DS365	Blue	Port16: Link Activity Status Output
DS366	Blue	Port15: Link Activity Status Output
DS367	Blue	Port14: Link Activity Status Output
DS368	Blue	Port13: Link Activity Status Output
DS369	Blue	Port12: Link Activity Status Output
DS370	Blue	Port11: Link Activity Status Output
DS371	Blue	Port10: Link Activity Status Output
DS372	Blue	Port9: Link Activity Status Output
DS373	Blue	Port8: Link Activity Status Output
DS374	Blue	Port7: Link Activity Status Output
DS375	Blue	Port6: Link Activity Status Output
DS376	Blue	Port5: Link Activity Status Output
DS377	Blue	Port4: Link Activity Status Output
DS378	Blue	Port3: Link Activity Status Output
DS379	Blue	Port2: Link Activity Status Output
DS380	Blue	Port1: Link Activity Status Output
DS381	Blue	Port0: Link Activity Status Output

Table 2.20 LED Indicators (Part 8 of 8)

Notes

EB-LOGAN-23 Board Figure

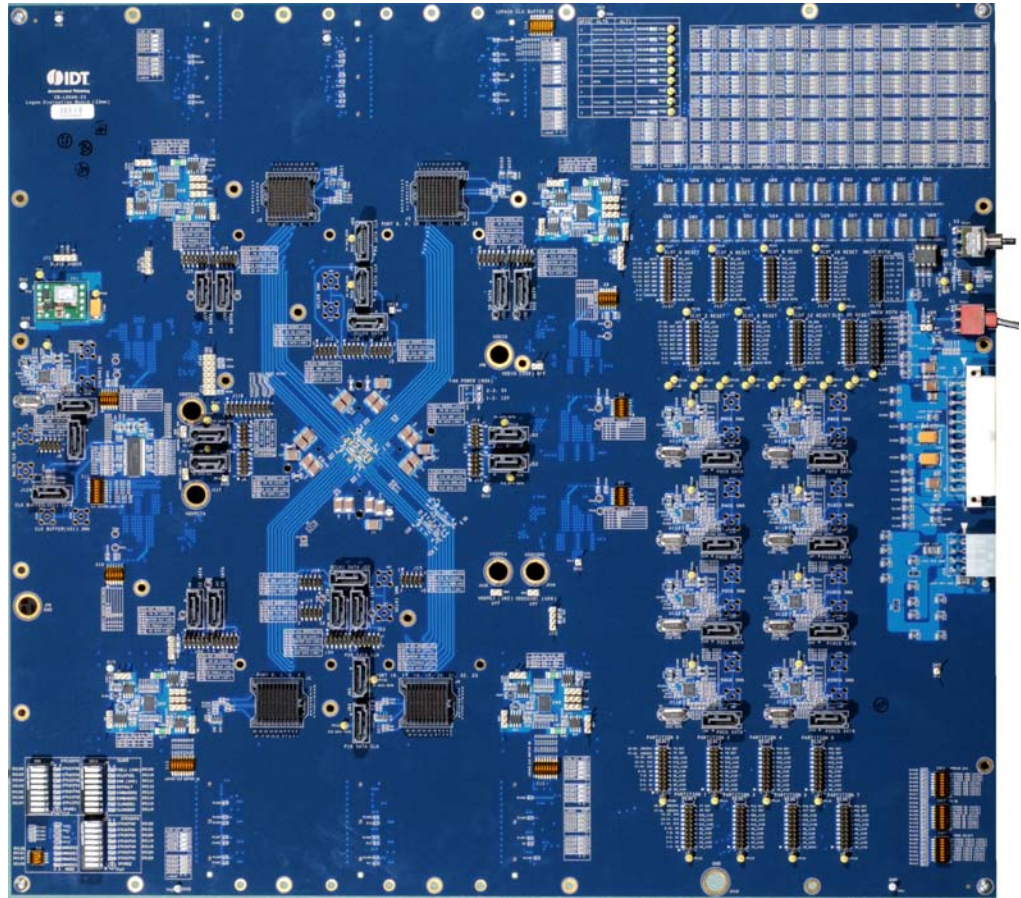

Figure 2.11 EB32NT24AG2 Evaluation Board

Notes



Software For EB-LOGAN-23

Notes

Introduction

This chapter discusses some of the main features of the available software to give users a better understanding of what can be achieved with the EB-LOGAN-23 evaluation board using the device management software.

Device management software and related user documentation are available on a CD which is included in the Evaluation Board Kit. This information is also available on IDT FTP site and also at my.idt.com. For more information, please go to: <http://www.idt.com/?app=TechSupport&prodFamily=PCIe%20Switches> or email IDT at ssdhelp@idt.com.

Device Management Software

The primary use of the Device Management Software package is to enable users of the evaluation board to access all the registers in the PES32NT24AG2 device. This access can be achieved using the PCI Express in-band configuration cycles through the upstream port on the PES32NT24AG2 or through the SMBUS salve interface available on the IDT PCIe switch.

This software also enables users to save a snapshot of the current register set into a dump file which can be used for debugging purposes. An export/import facility is also available to create and use "Configuration" files which can be used to initialize the switch device with specific values in specific registers.

A conversion utility is also provided to translate a configuration file into an EEPROM programmable data structure. This enables the user to program an appropriate serial EEPROM with desirable register settings for the PES32NT24AG2, and then to populate that EEPROM onto the Evaluation Board. It is also possible to program the EEPROM directly on the Evaluation Board using a feature provided by the software package.

The front-end of the Device Management Software is a user-friendly Graphical User Interface which allows the user to quickly read or write the registers of interest. The GUI also permits the user to run the software in "simulation" mode with no real hardware attached, allowing the creation of configuration files for the PES32NT24AG2 in the absence of the actual device.

Much of the Device Management Software is written with device-independent and OS-independent code. The software is expected to work on Linux (/sys interface) and MS Windows XP. It may function well on various flavors of MS Windows, but may not be validated on all. The fact that the software is device-independent assures its scalability to future PCIe parts from IDT. Once users are familiar with the GUI, they will be able to use the same GUI on all PCIe parts from IDT. This software is customized for each device through an XML device description file which includes information on the number of ports, registers, types of registers, information on bit-fields within each register, etc.

The actual program name of the Device Management Software is "PCIEBrowser" (an executable file under Windows or Linux). Revision 5.0.1 or later is required for devices in the PES32NT24AG2 product family.

Device Drivers

The PES32NT24AG2 and other members of this switch family offer Non-Transparent Bridging and built-in DMA capability inside the device. Device drivers are needed to take advantage of these features. Sample code for these drivers is available from IDT for the Linux operating system. Additionally, there are a few other software packages available from IDT. These packages are not related to the evaluation board per se, and therefore not listed here. However, several of these packages may prove to be useful for specific device or system functionality. For more information, please go to <http://www.idt.com/?app=TechSupport&prodFamily=PCIe%20Switches> or email IDT at ssdhelp@idt.com.

Notes



Schematics

Notes

Schematics

REVISIONS				
DCN	REV	DESCRIPTION	DATE	CHANGE BY
	1.0	INITIAL RELEASE	2009-12-05	T. TRAN

1. TITLE PAGE / TABLE OF CONTENTS

2.	MEZZANINE CONNECTOR PORTS	0, 2	27.	POWER REGULATOR - VDDIO
3.	MEZZANINE CONNECTOR PORTS	4, 6	28.	POWER REGULATOR - VDDCORE
4.	MEZZANINE CONNECTOR PORTS	8, 12	29.	POWER REGULATOR - VDDPEA
5.	MEZZANINE CONNECTOR PORTS	16, 20	30.	POWER REGULATOR - VDDPEHA
6.	32NT24AG2 - SERDES		31.	POWER REGULATOR - VDDPETA
7.	32NT24AG2 - CLK, CONFIG, GPIO		32.	RESET, SMBUS, EEPROM, JTAG
8.	32NT24AG2 - POWER, GND		33.	DIP SWITCHES
9.	IOEXPANDER	0-3	34.	LED - PORT STATUS (1 OF 7)
10.	IOEXPANDER	4-7	35.	LED - PORT STATUS (2 OF 7)
11.	IOEXPANDER	8-11	36.	LED - PORT STATUS (3 OF 7)
12.	IOEXPANDER	12-13	37.	LED - PORT STATUS (4 OF 7)
13.	IOEXPANDER	16-19	38.	LED - PORT STATUS (5 OF 7)
14.	IOEXPANDER	20-21	39.	LED - PORT STATUS (6 OF 7)
15.	HOT PLUG CONTROL PORTS	0-2	40.	LED - PORT STATUS (7 OF 7)
16.	HOT PLUG CONTROL PORTS	4-6	41.	MIN LOAD RESISTORS
17.	HOT PLUG CONTROL PORTS	8-12	42.	12PK RIBBON CONNECTORS
18.	HOT PLUG CONTROL PORTS	16-20	43.	PARTITION RESET SELECT HEADERS
19.	SLOT RESETS AND WAKE PULL-UPS		44.	SLOT RESET SELECT HEADERS
20.	CLOCK GENERATOR / SOURCE INPUT		45.	PORT 0 CLOCK GENERATOR
21.	CLOCK BUFFER - 1		46.	PORT 2 CLOCK GENERATOR
22.	CLOCK SELECTOR DUT PCLK	8	47.	PORT 4 CLOCK GENERATOR
23.	CLOCK SELECTOR DUT PCLK	16	48.	PORT 6 CLOCK GENERATOR
24.	CLOCK SELECTOR - DUT PCLK	0-20, GCLK 1-2	49.	PORT 8 CLOCK GENERATOR
25.	CLOCK SELECTOR - SLOTS	0-20	50.	PORT 12 CLOCK GENERATOR
26.	POWER CONNECTORS		51.	PORT 16 CLOCK GENERATOR
			52.	PORT 20 CLOCK GENERATOR

		TITLE		
		EB-LOGAN-23		
SIZE	DRAWING NO.	FAB P/N	REV.	
B	SCH-PESEB-001	18-691-001	2.0	
AUTHOR		CHECKED BY		
Tony Tran		Derek Huang		
Thu Jul 01 15:00:52 2010			SHEET 1 OF 52	

CONFIDENTIAL PROPERTY OF INTEGRATED DEVICE TECHNOLOGY, INC.
 6024 SILVER CREEK VALLEY ROAD, SAN JOSE, CA 95138
 COPYRIGHT (C) 2010

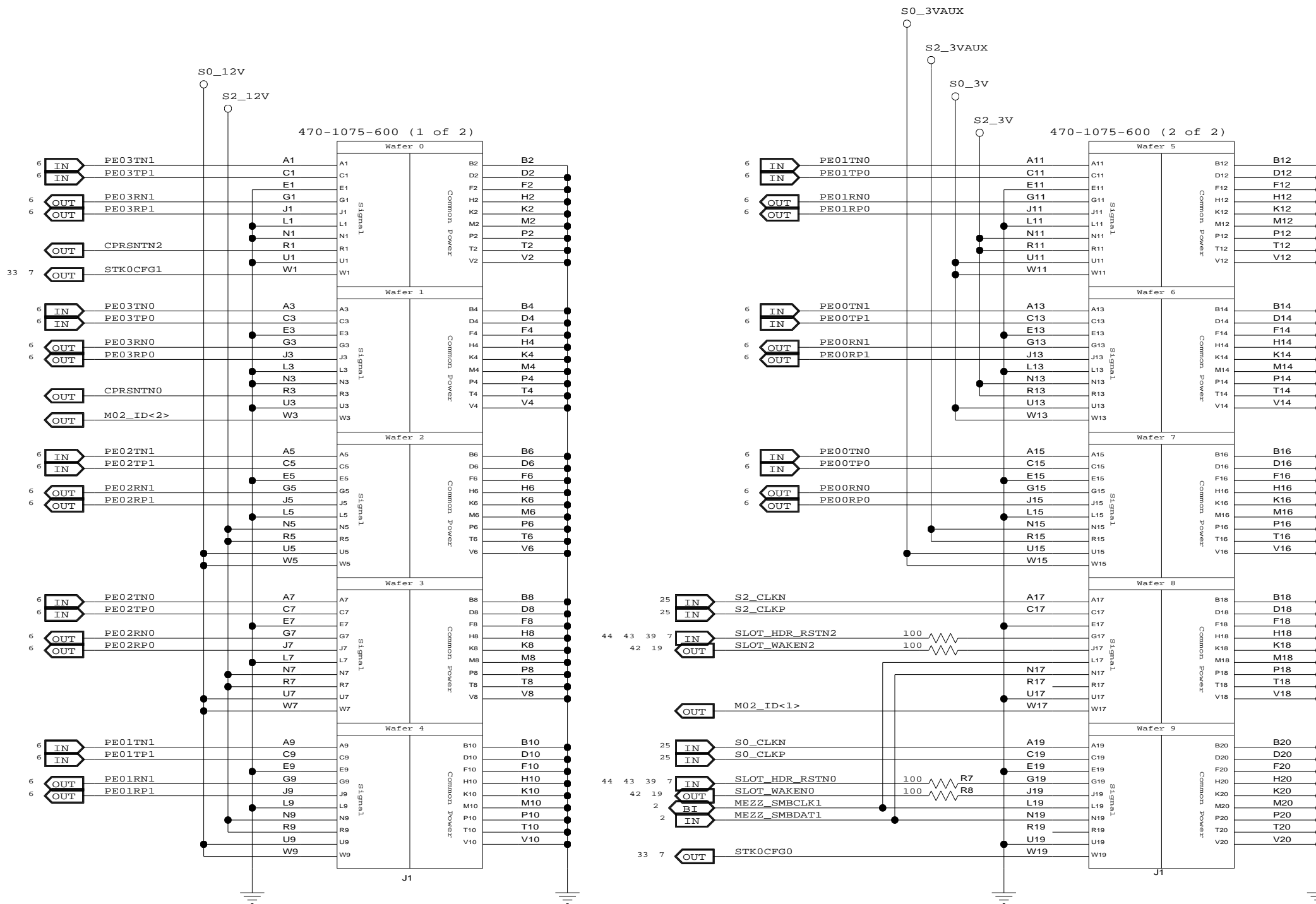

STK0CFG1 & STK0CFG0 SET BY MEZZ CARDS
 X8 - STK0CFG1 = 0, STK0CFG0 = 0
 X4 - STK0CFG1 = 0, STK0CFG0 = 1

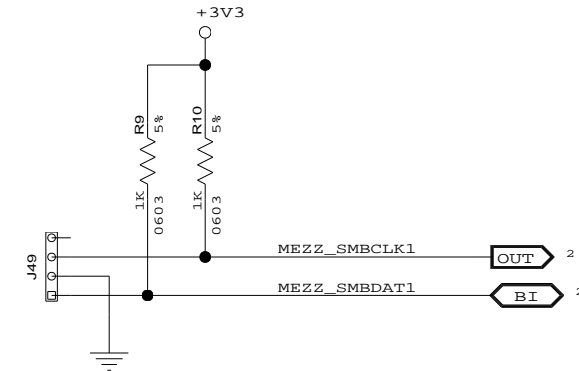

CONFIDENTIAL PROPERTY OF INTEGRATED DEVICE TECHNOLOGY, INC.
 6024 SILVER CREEK VALLEY ROAD, SAN JOSE, CA 95138
 COPYRIGHT (C) 2010 IDT

TITLE EB-LOGAN-23

MEZZANINE CONNECTOR PORTS 0/2

SIZE B	DRAWING NO. SCH-PESEB-001	FAB P/N 18-691-001	REV. 2.0
AUTHOR Tony Tran		CHECKED BY Derek Huang	

Thu Jul 01 15:00:53 2010

SHEET 2 OF 52

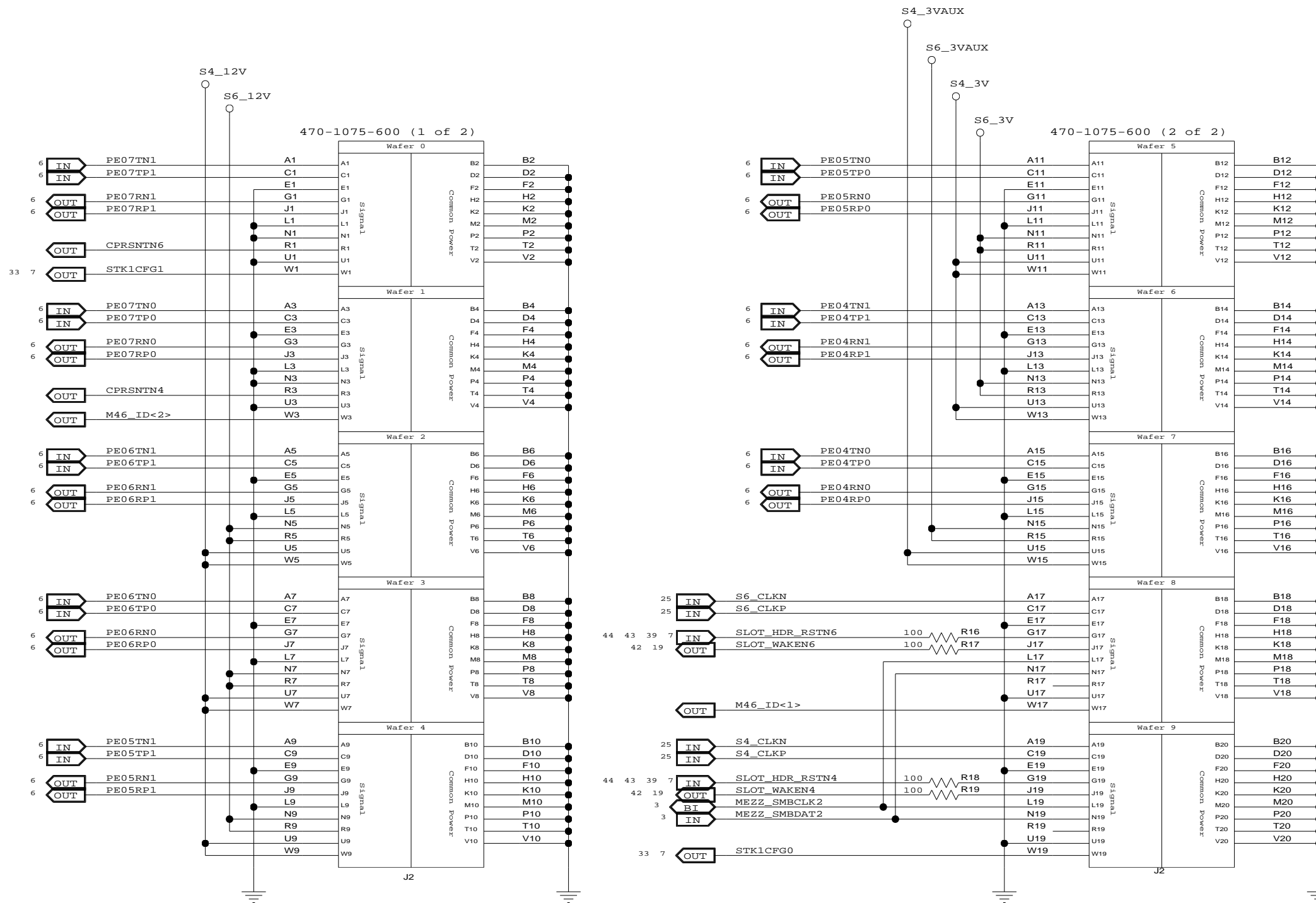

STK1CFG1 & STK1CFG0 SET BY MEZZ CARDS
 X8 - STK1CFG1 = 0, STK1CFG0 = 0
 X4 - STK1CFG1 = 0, STK1CFG0 = 1

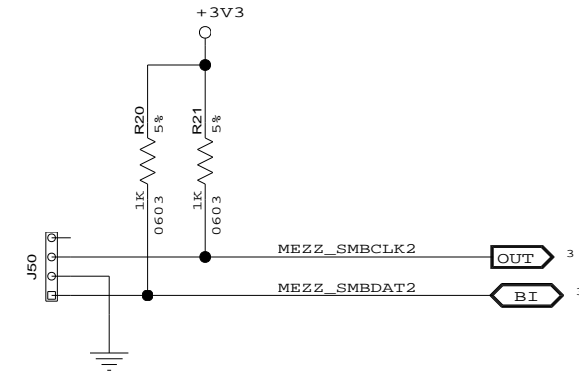

CONFIDENTIAL PROPERTY OF INTEGRATED DEVICE TECHNOLOGY, INC.
 6024 SILVER CREEK VALLEY ROAD, SAN JOSE, CA 95138
 COPYRIGHT (C) 2010 IDT

TITLE EB-LOGAN-23			
MEZZANINE CONNECTOR PORTS 4/6			
SIZE	DRAWING NO.	FAB P/N	REV.
B	SCH-PESEB-001	18-691-001	2.0
AUTHOR		CHECKED BY	
Tony Tran		Derek Huang	
Thu Jul 01 15:00:53 2010			SHEET 3 OF 52

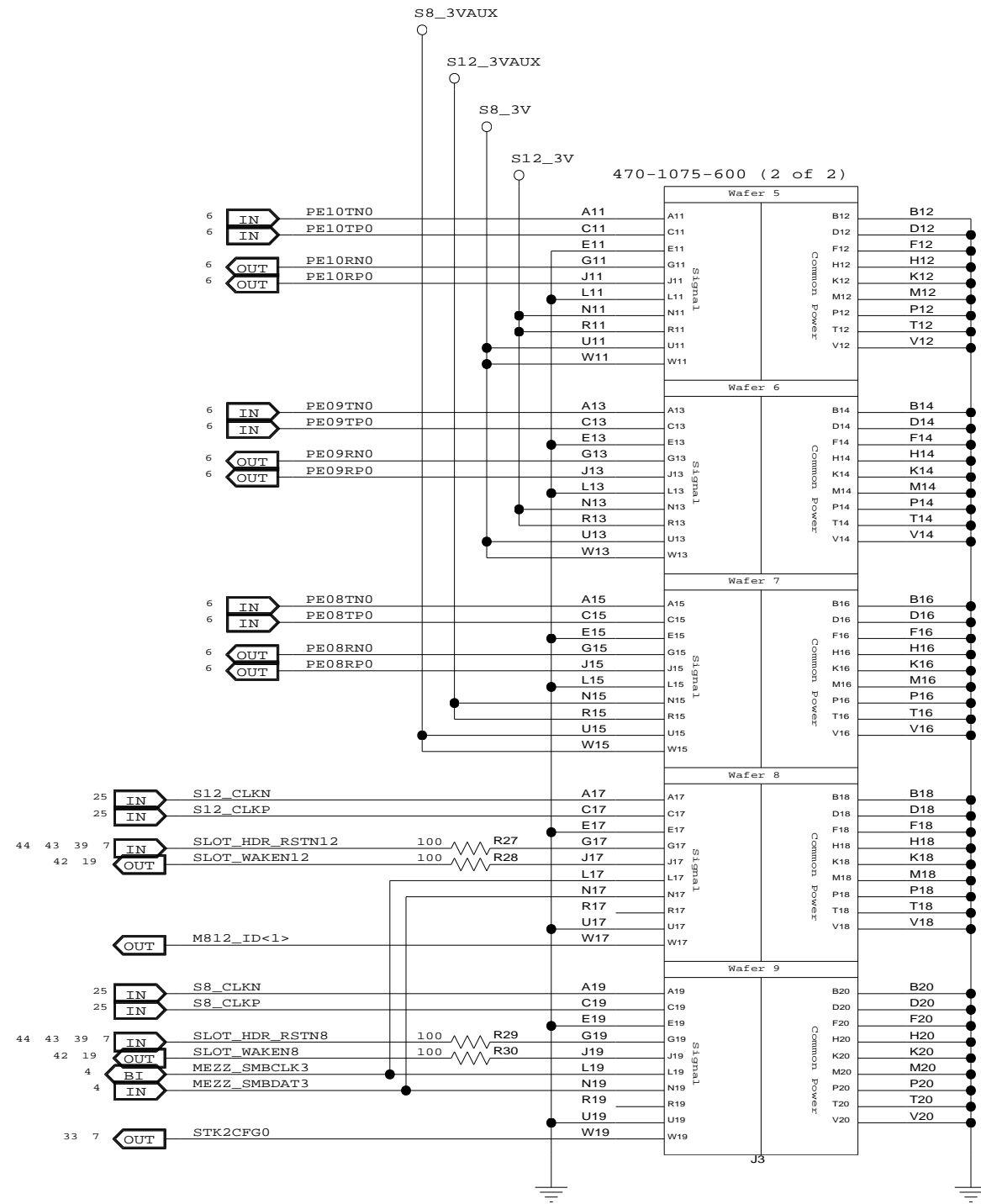
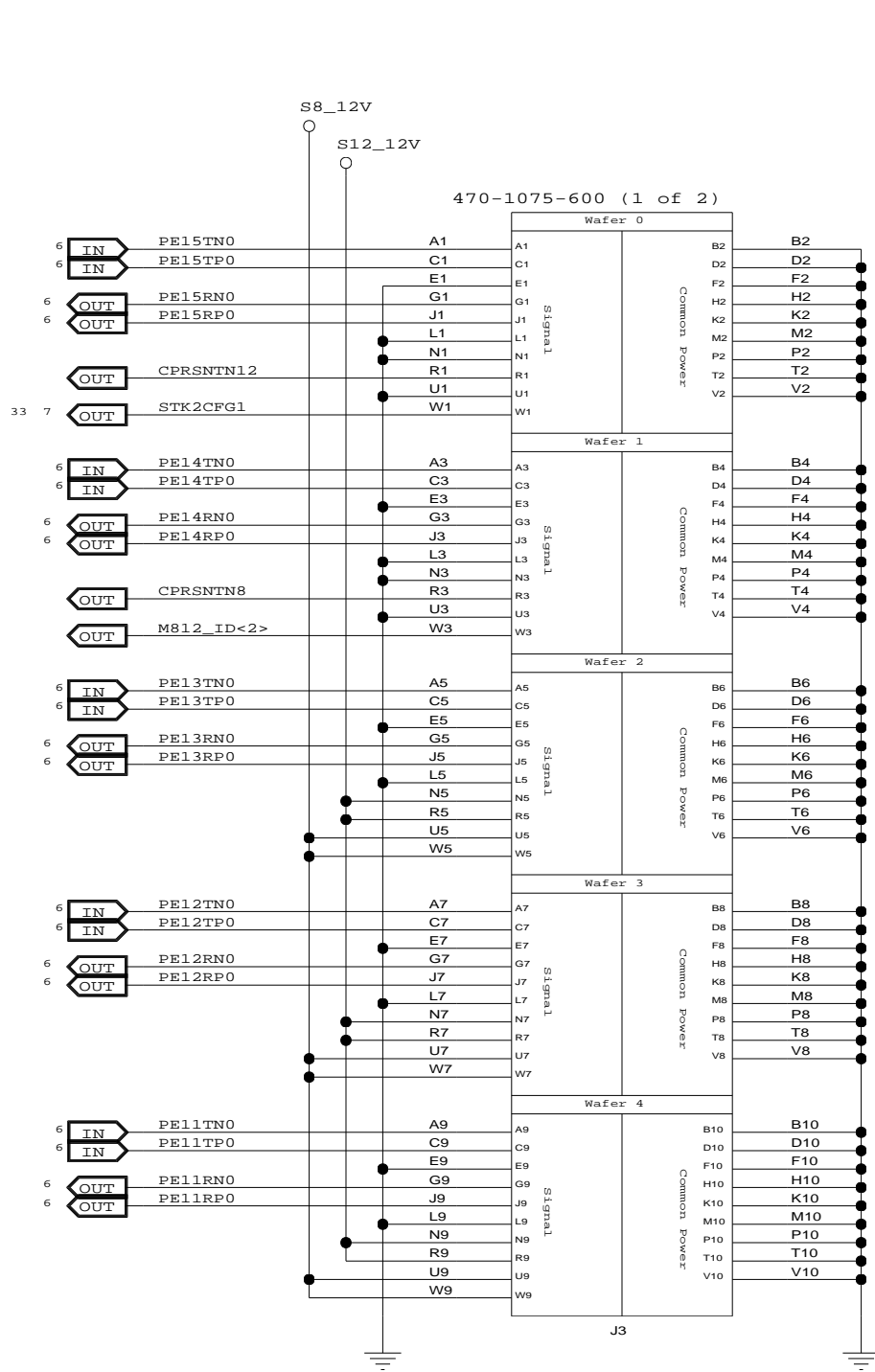

STK2CFG1 & STK2CFG0 SET BY MEZZ CARDS
 X8 - STK2CFG1 = 0, STK2CFG0 = 0
 X4 - STK2CFG1 = 0, STK2CFG0 = 1

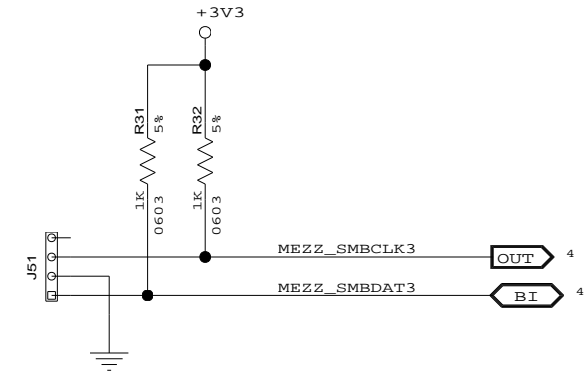

CONFIDENTIAL PROPERTY OF INTEGRATED DEVICE TECHNOLOGY, INC.
 6024 SILVER CREEK VALLEY ROAD, SAN JOSE, CA 95138
 COPYRIGHT (C) 2010 IDT

TITLE EB-LOGAN-23			
MEZZANINE CONNECTOR PORTS 8/12			
SIZE	DRAWING NO.	FAB P/N	REV.
B	SCH-PESEB-001	18-691-001	2.0
AUTHOR		CHECKED BY	
Tony Tran		Derek Huang	
Thu Jul 01 15:00:53 2010			SHEET 4 OF 52

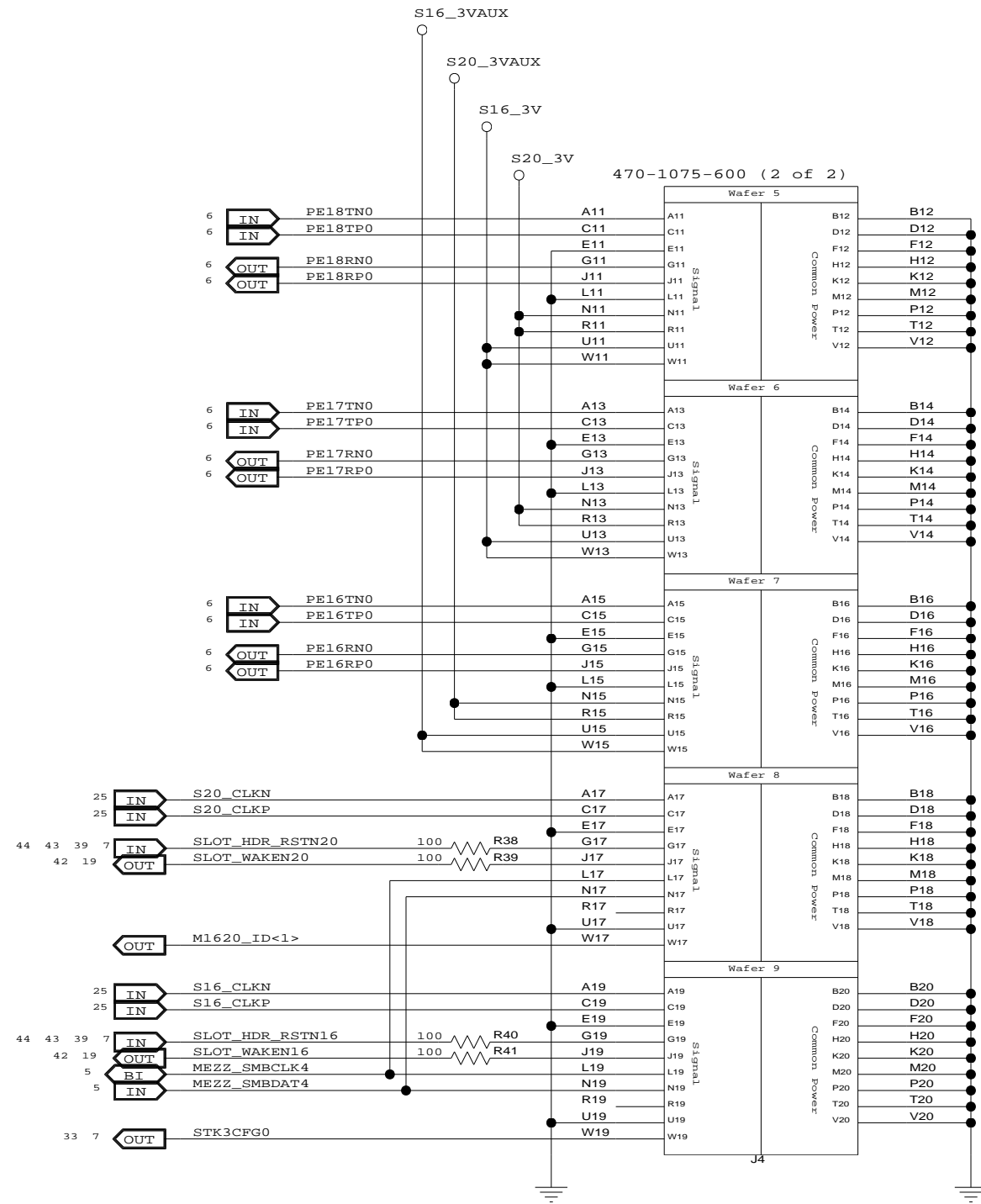
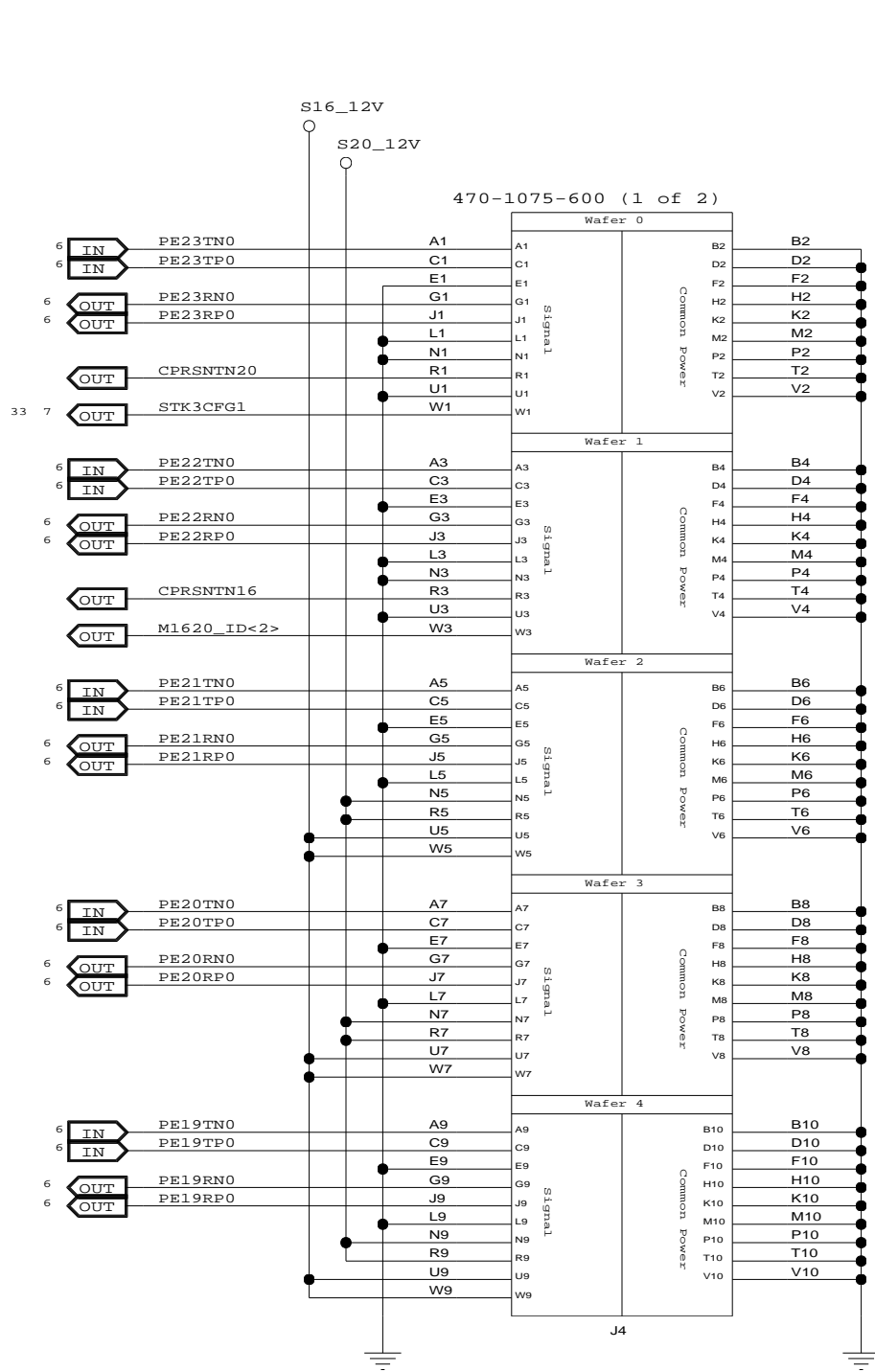

STK3CFG1 & STK3CFG0 SET BY MEZZ CARDS
 X8 - STK3CFG1 = 0, STK3CFG0 = 0
 X4 - STK3CFG1 = 0, STK3CFG0 = 1

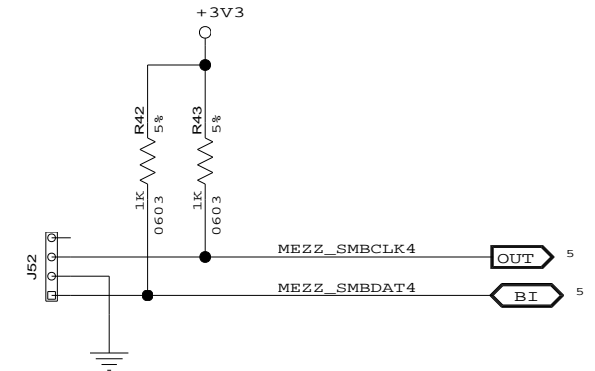

CONFIDENTIAL PROPERTY OF INTEGRATED DEVICE TECHNOLOGY, INC.
 6024 SILVER CREEK VALLEY ROAD, SAN JOSE, CA 95138
 COPYRIGHT (C) 2010 IDT

TITLE EB-LOGAN-23			
MEZZANINE CONNECTOR PORTS 16/20			
SIZE	DRAWING NO.	FAB P/N	REV.
B	SCH-PESEB-001	18-691-001	2.0
AUTHOR		CHECKED BY	
Tony Tran		Derek Huang	
Thu Jul 01 15:00:53 2010			SHEET 5 OF 52

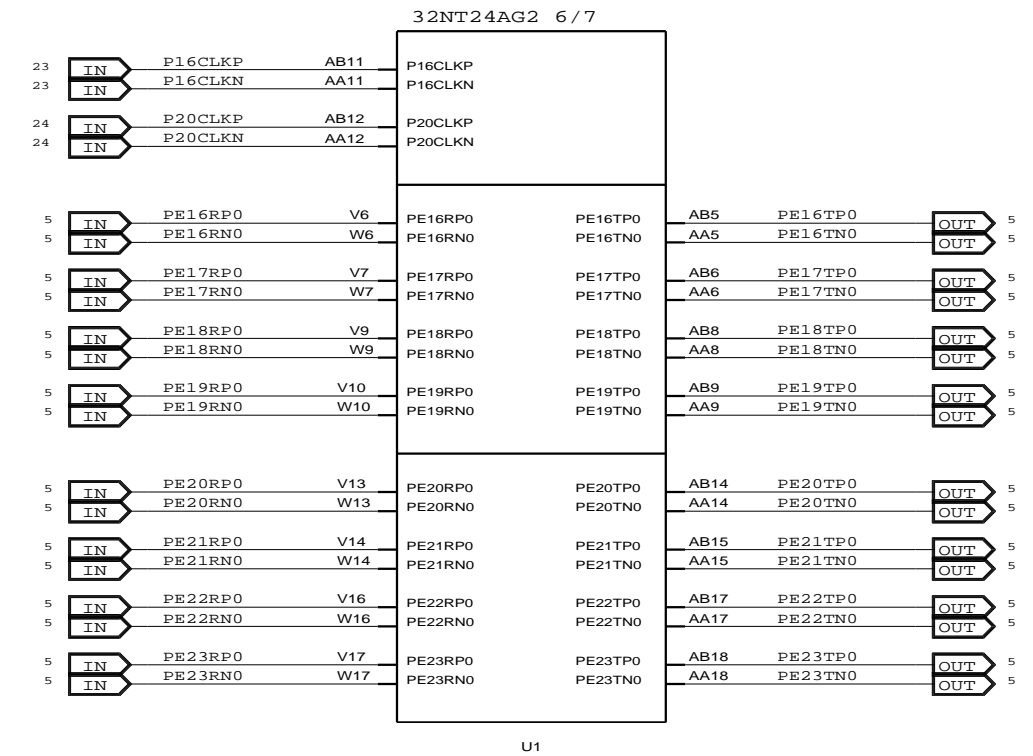
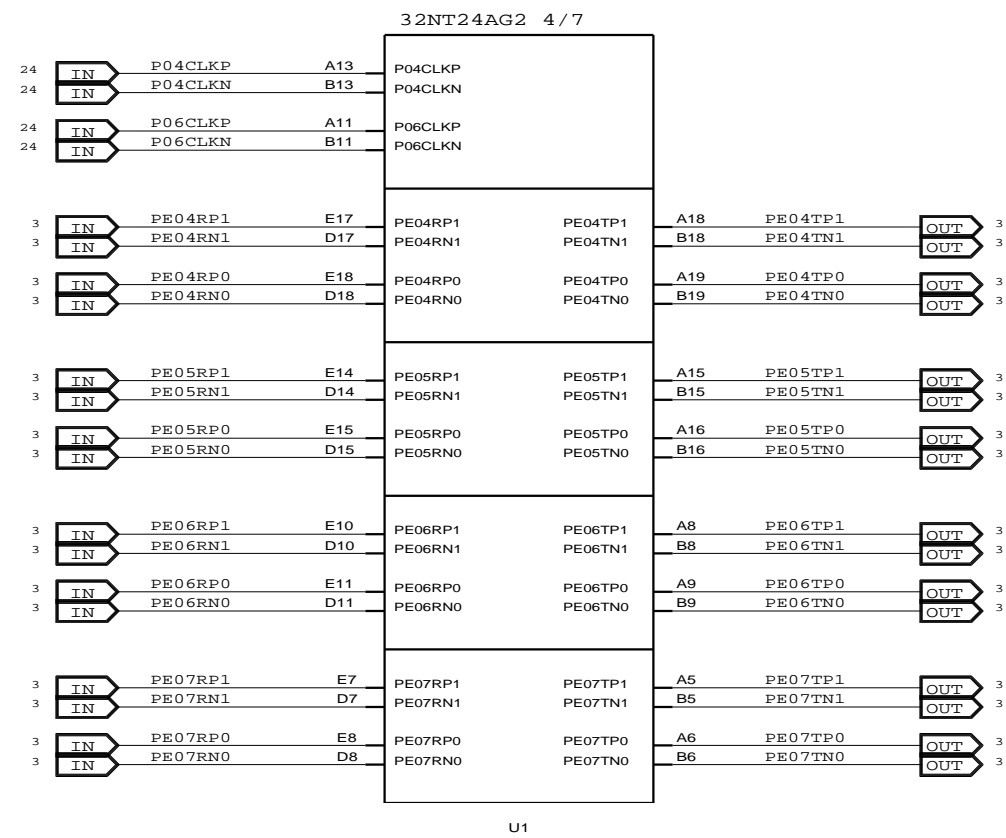
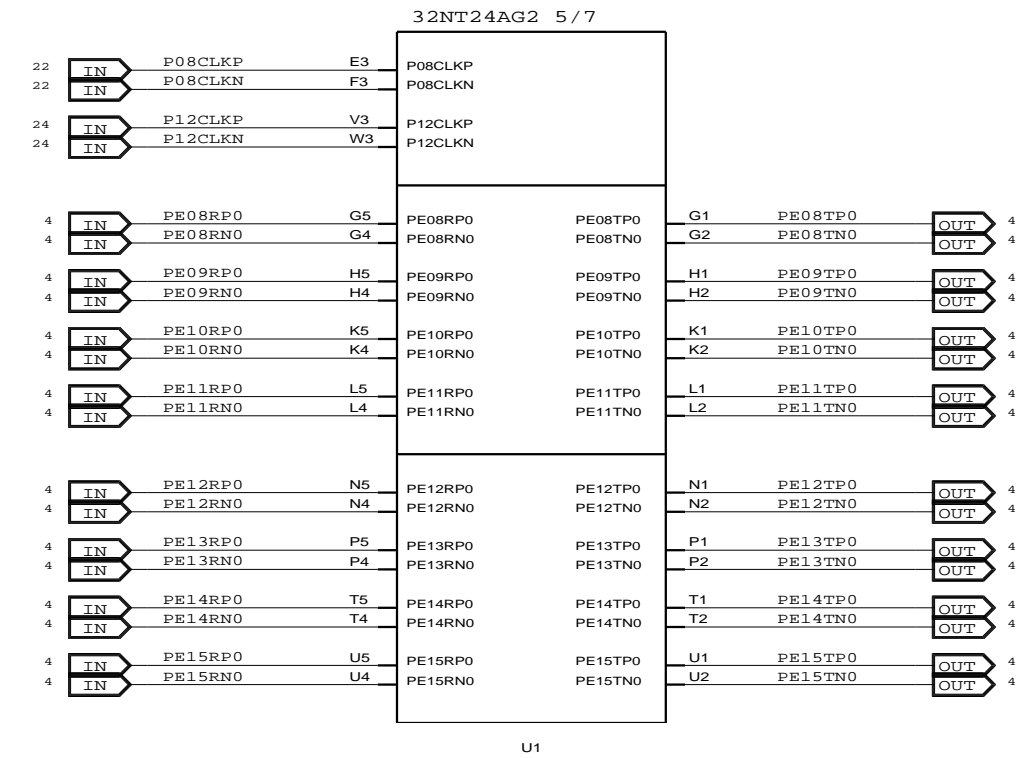
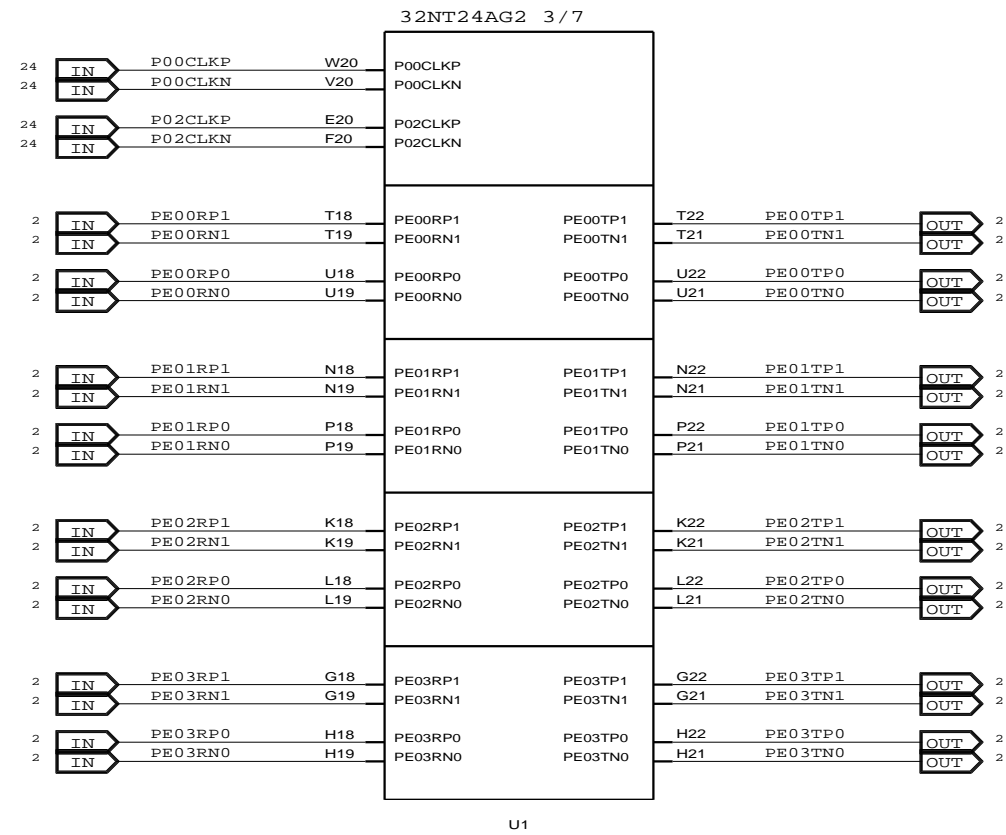

		TITLE EB-LOGAN-23		
		32NT24AG2 - SERDES		
SIZE	DRAWING NO.	FAB P/N	REV.	
B	SCH-PESEB-001	18-691-001	2.0	
AUTHOR		CHECKED BY		
Tony Tran		Derek Huang		
Thu Jul 01 15:00:54 2010			SHEET 6 OF 52	

CONFIDENTIAL PROPERTY OF INTEGRATED DEVICE TECHNOLOGY, INC.
6024 SILVER CREEK VALLEY ROAD. SAN JOSE, CA 95138
COPYRIGHT (C) 2010 IDT

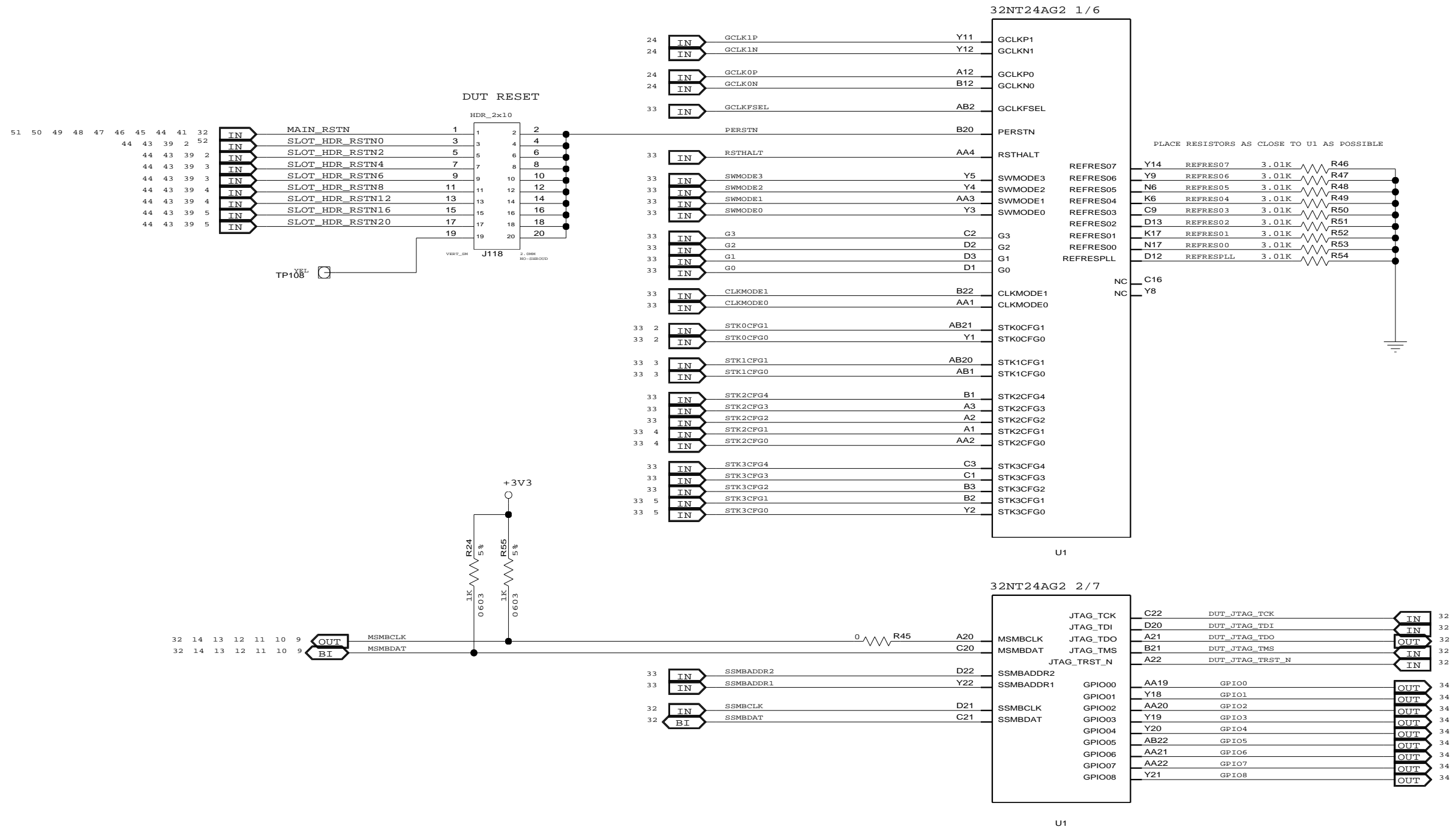

CONFIDENTIAL PROPERTY OF INTEGRATED DEVICE TECHNOLOGY, INC.
6024 SILVER CREEK VALLEY ROAD. SAN JOSE, CA 95138
COPYRIGHT (C) 2010 IDT

TITLE EB-LOGAN-23

32NT24AG2 CLK, CONFIG, GPIO

SIZE	DRAWING NO.	FAB P/N	REV.
B	SCH-PESEB-001	18-691-001	2.0

AUTHOR	CHECKED BY
Tony Tran	Derek Huang

Thu Jul 01 15:00:54 2010

SHEET 7 OF 52

LABEL: FAN
 LABEL:
 1 GND
 2 12V/5V
 3 NC

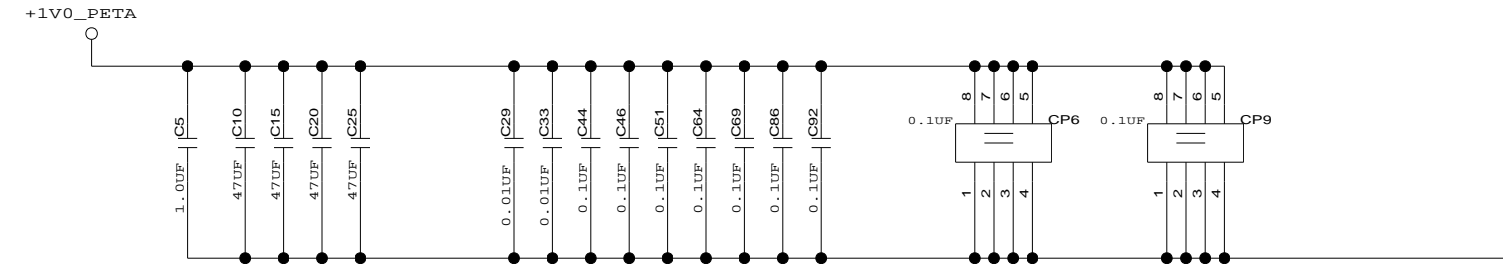
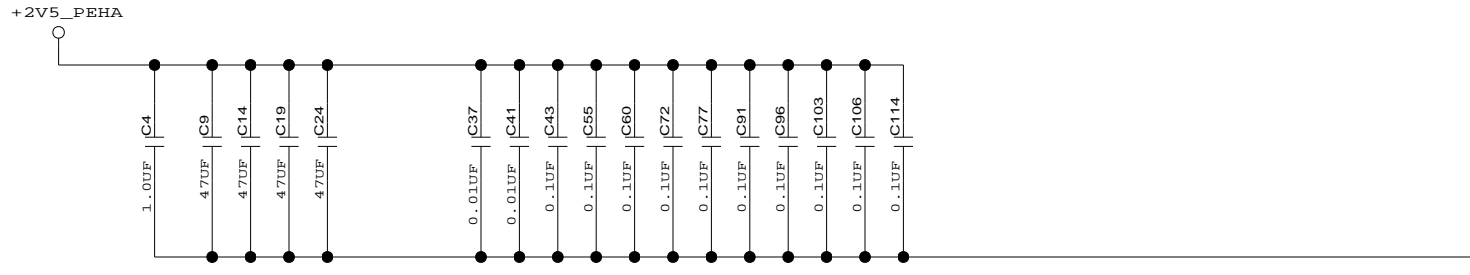
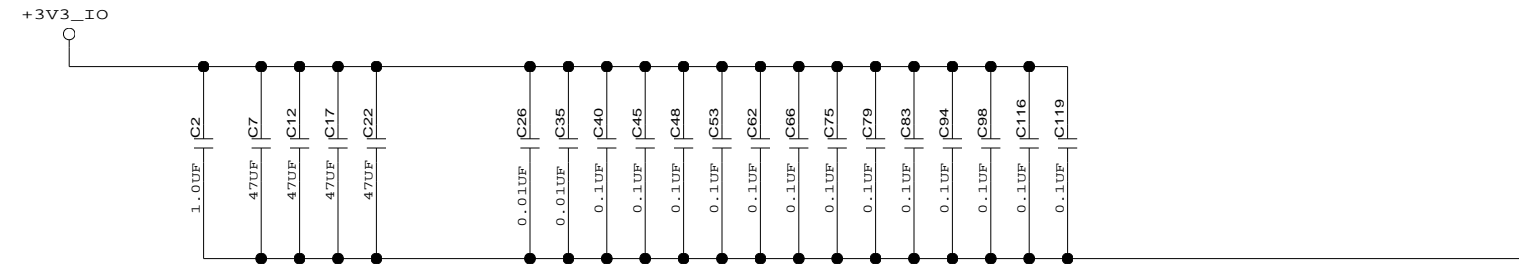
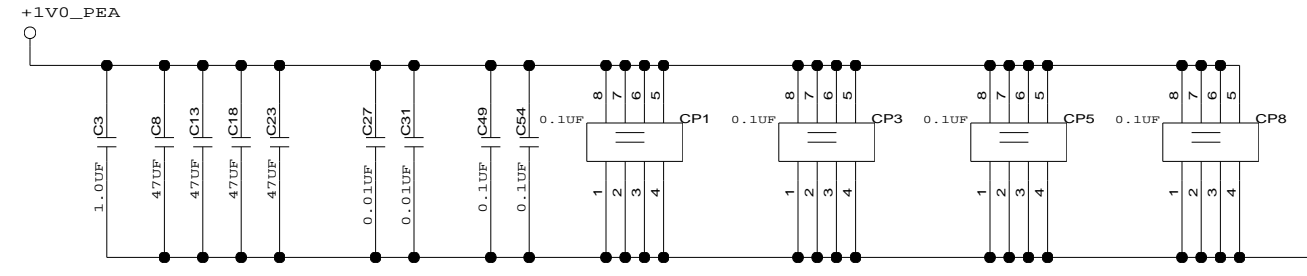
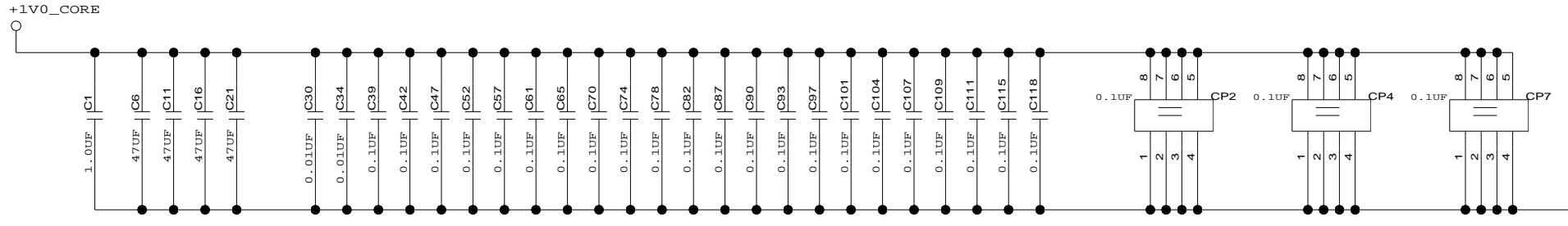
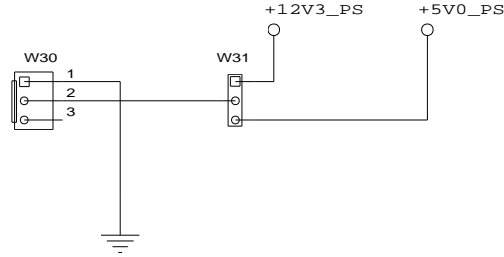

+2V5_PEAH
 +1V0_PETA
 +3V3_IO
 +1V0_PEA
 +1V0_CORE

32NT24AG2 7/7

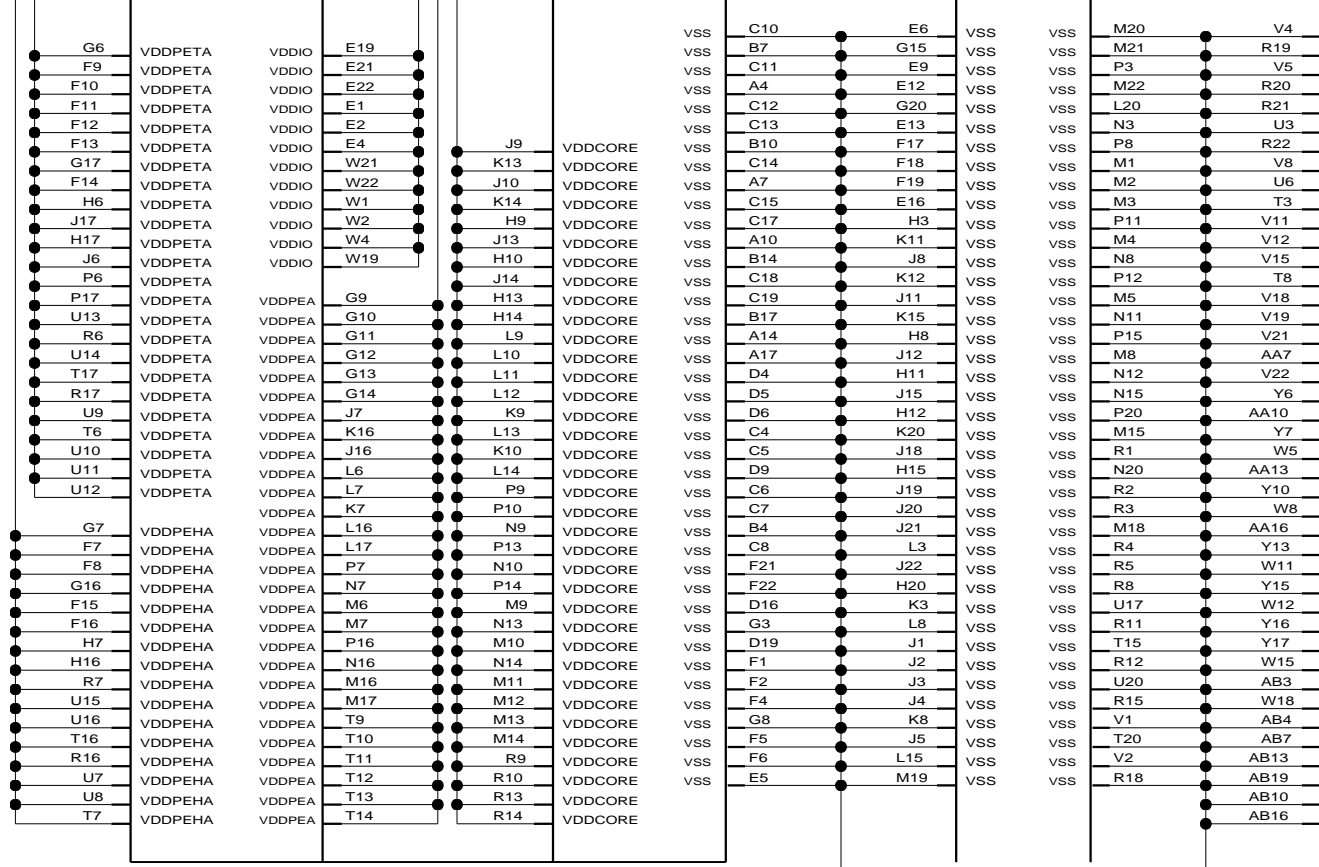

U1



CONFIDENTIAL PROPERTY OF INTEGRATED DEVICE TECHNOLOGY, INC.
 6024 SILVER CREEK VALLEY ROAD, SAN JOSE, CA 95138
 COPYRIGHT (C) 2010 IDT

TITLE EB-LOGAN-23			
32NT24AG2 - POWER			
SIZE B	DRAWING NO. SCH-PESEB-001	FAB P/N 18-691-001	REV. 2.0
AUTHOR Tony Tran		CHECKED BY Derek Huang	
Thu Jul 01 15:00:54 2010			SHEET 8 OF 52

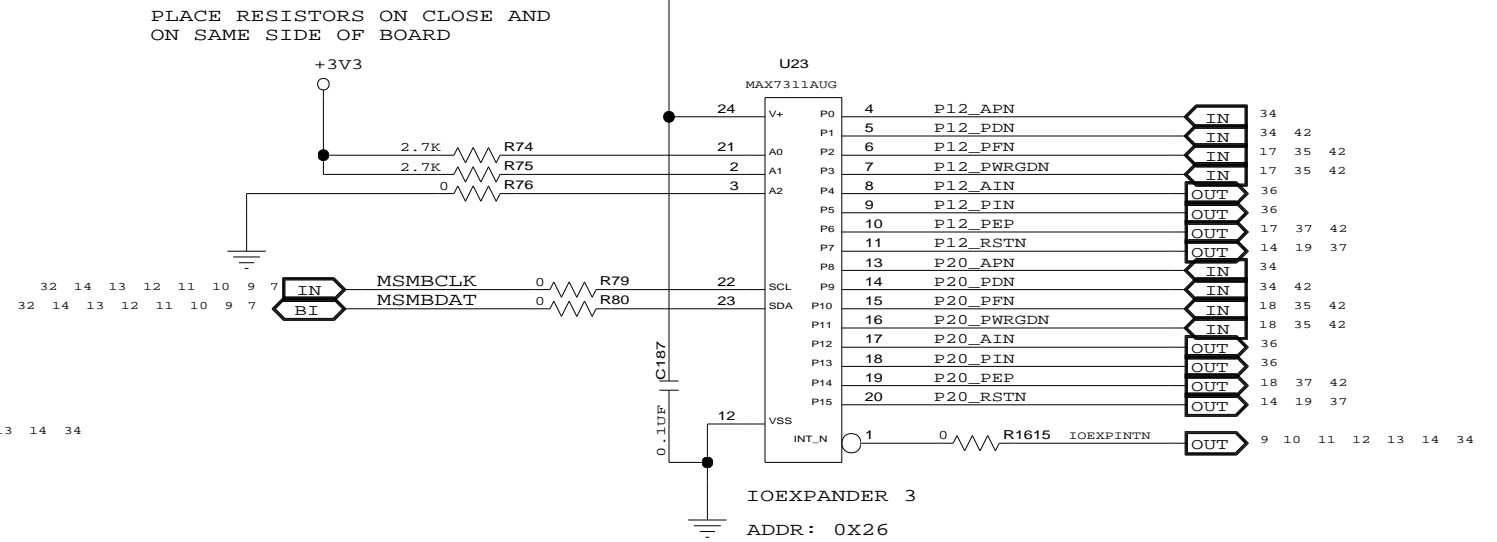
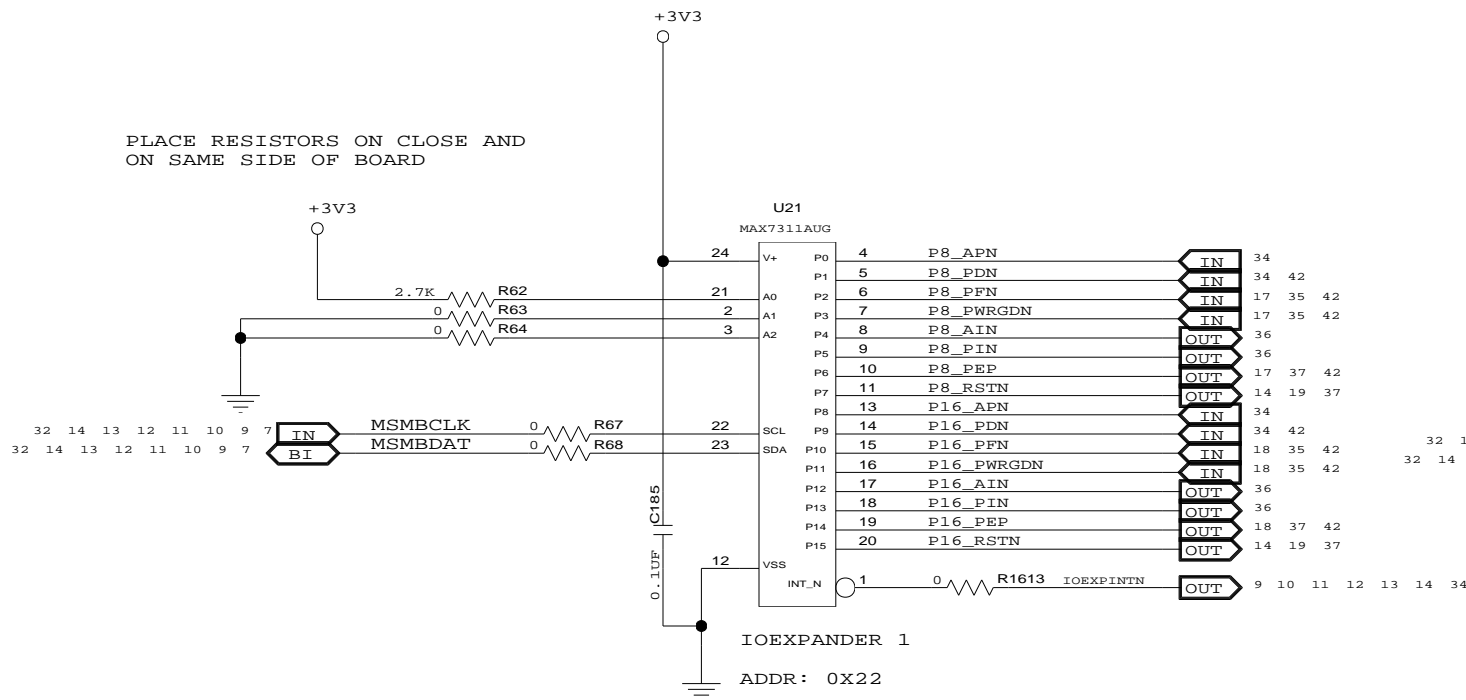
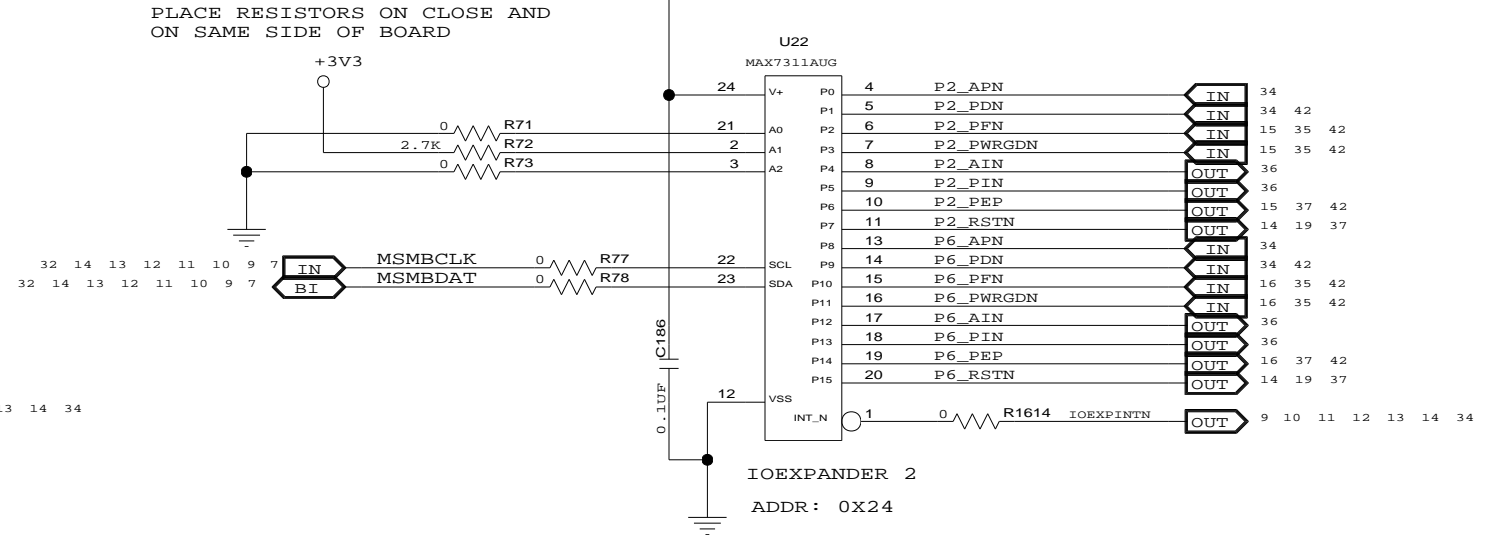
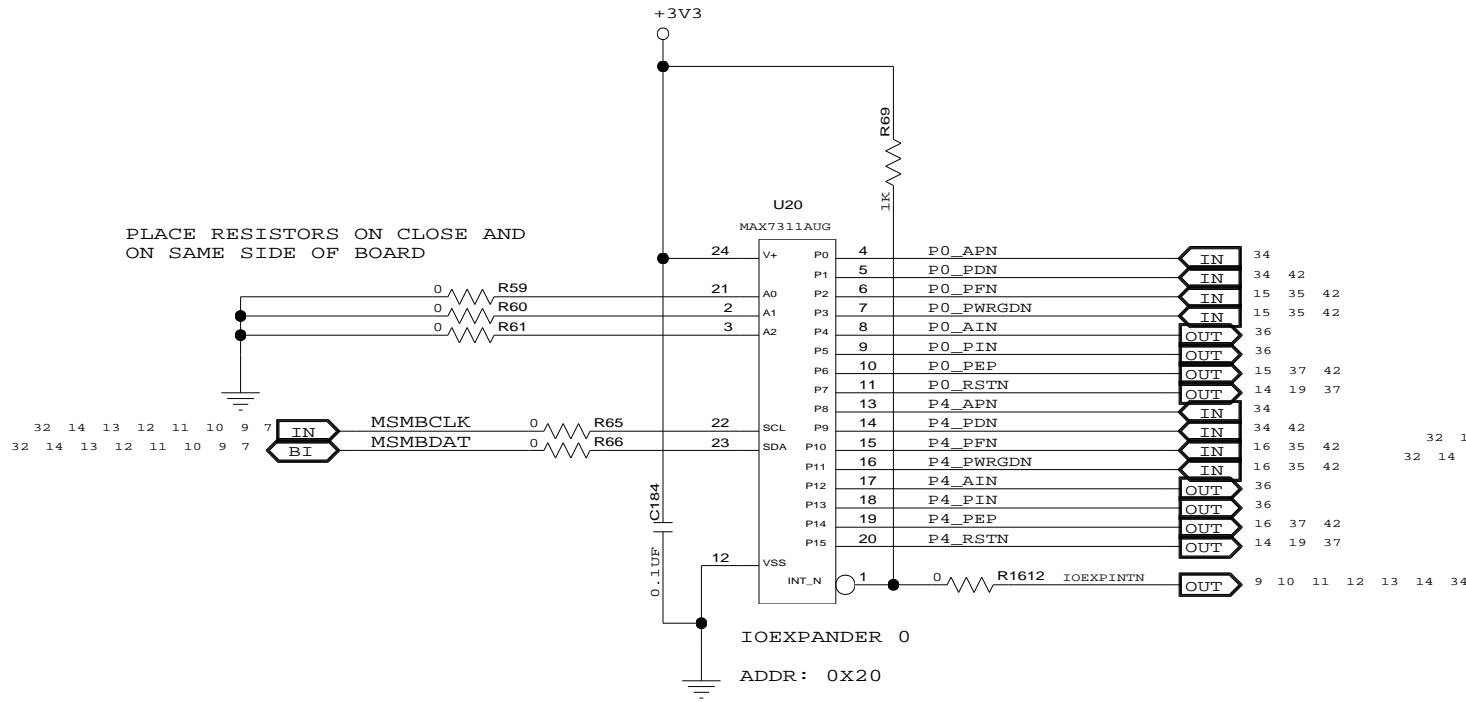

CONFIDENTIAL PROPERTY OF INTEGRATED DEVICE TECHNOLOGY, INC.
6024 SILVER CREEK VALLEY ROAD, SAN JOSE, CA 95138
COPYRIGHT (C) 2010 IDT

TITLE EB-LOGAN-23

IOEXPANDER 0-3

SIZE B	DRAWING NO. SCH-PESEB-001	FAB P/N 18-691-001	REV. 2.0
AUTHOR Tony Tran		CHECKED BY Derek Huang	
Thu Jul 01 15:00:55 2010			SHEET 9 OF 52

PLACE RESISTORS ON CLOSE AND ON SAME SIDE OF BOARD

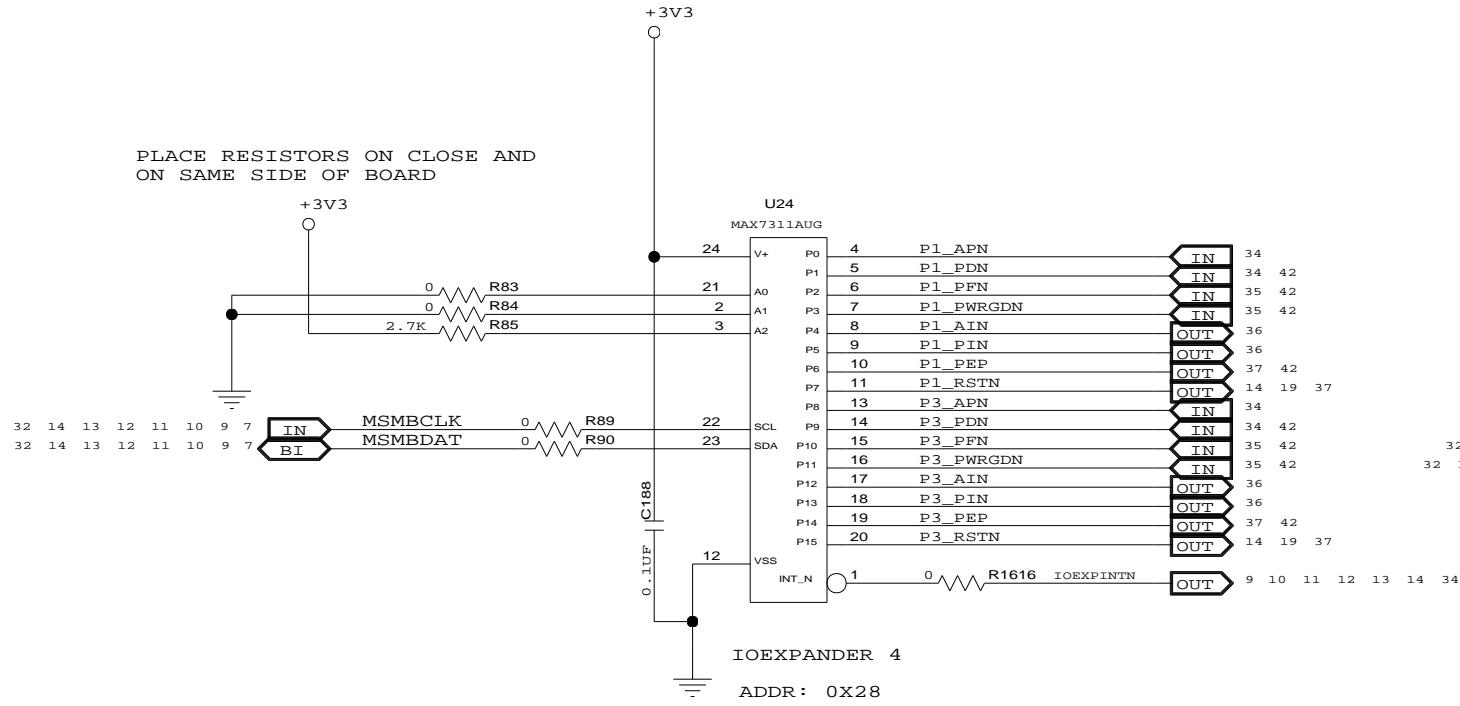

PLACE RESISTORS ON CLOSE AND ON SAME SIDE OF BOARD

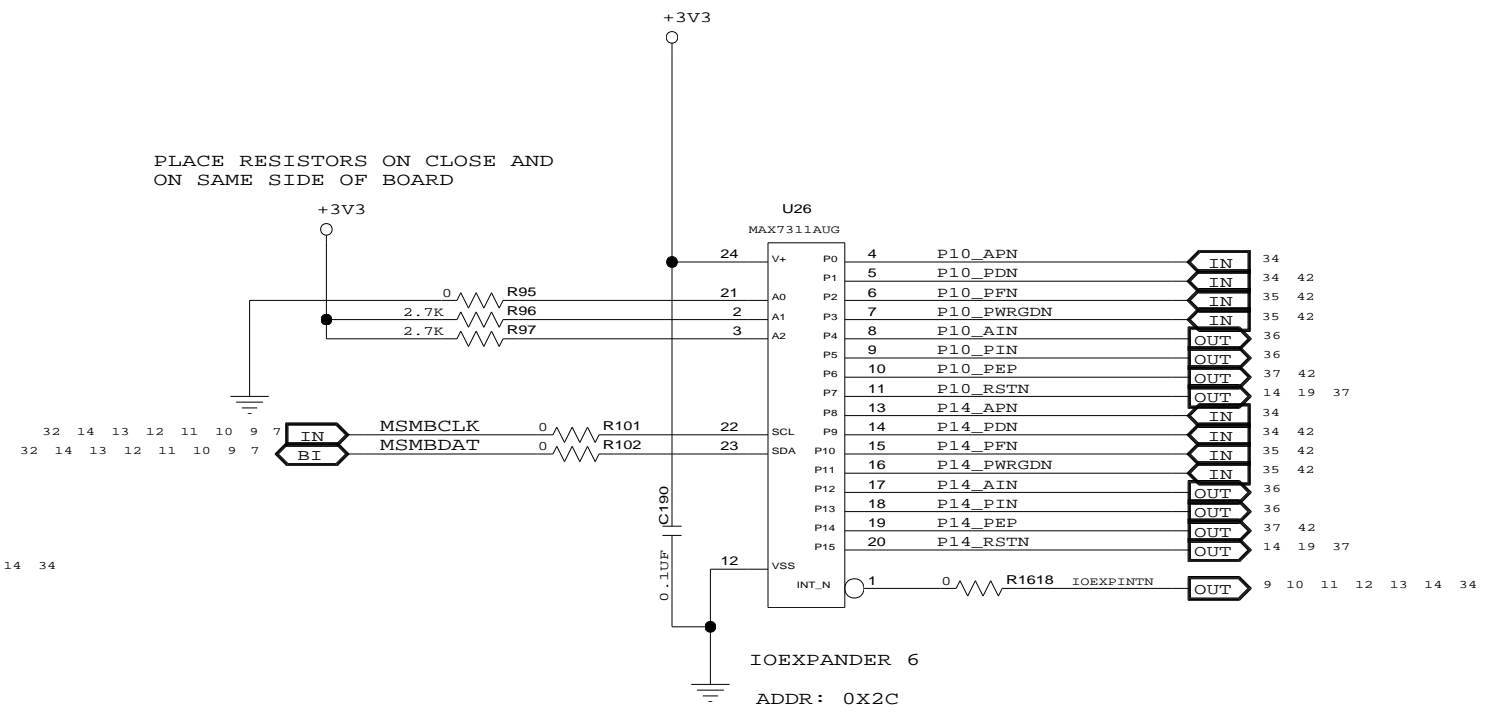

PLACE RESISTORS ON CLOSE AND ON SAME SIDE OF BOARD

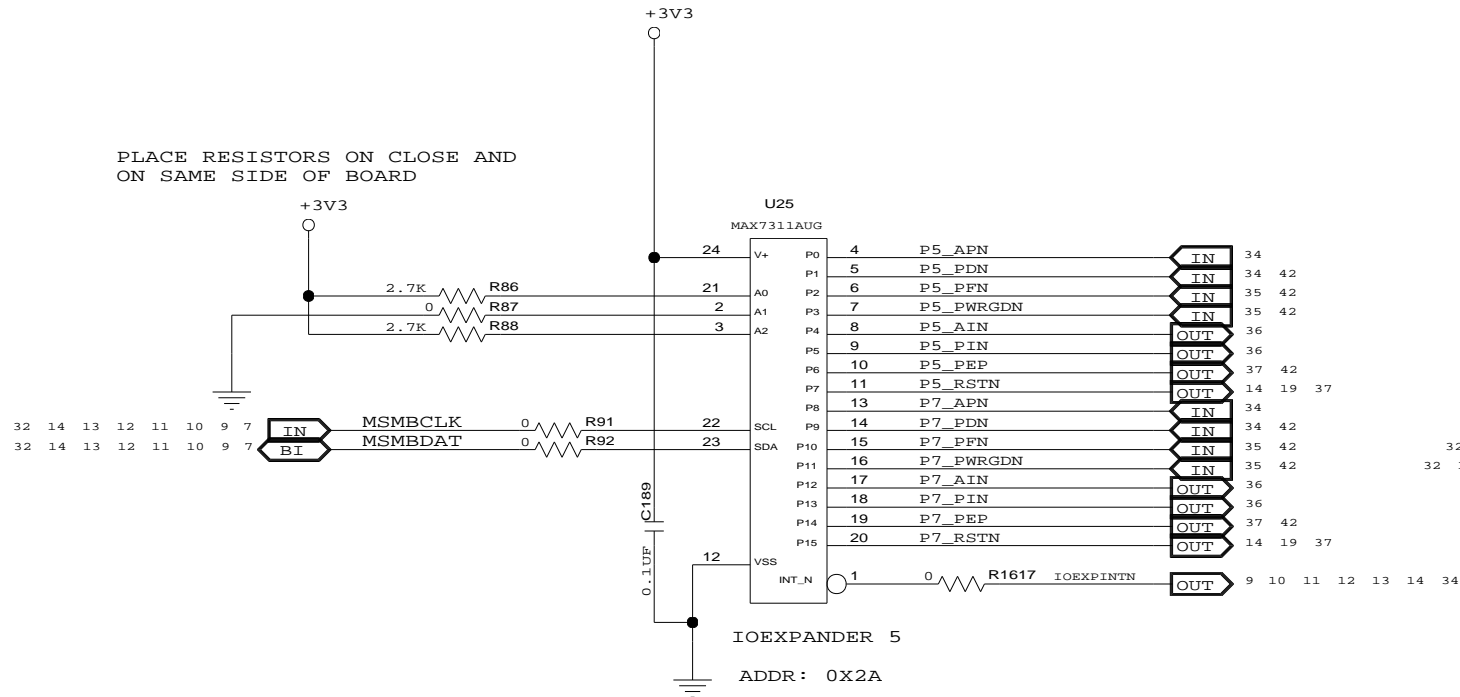

PLACE RESISTORS ON CLOSE AND ON SAME SIDE OF BOARD

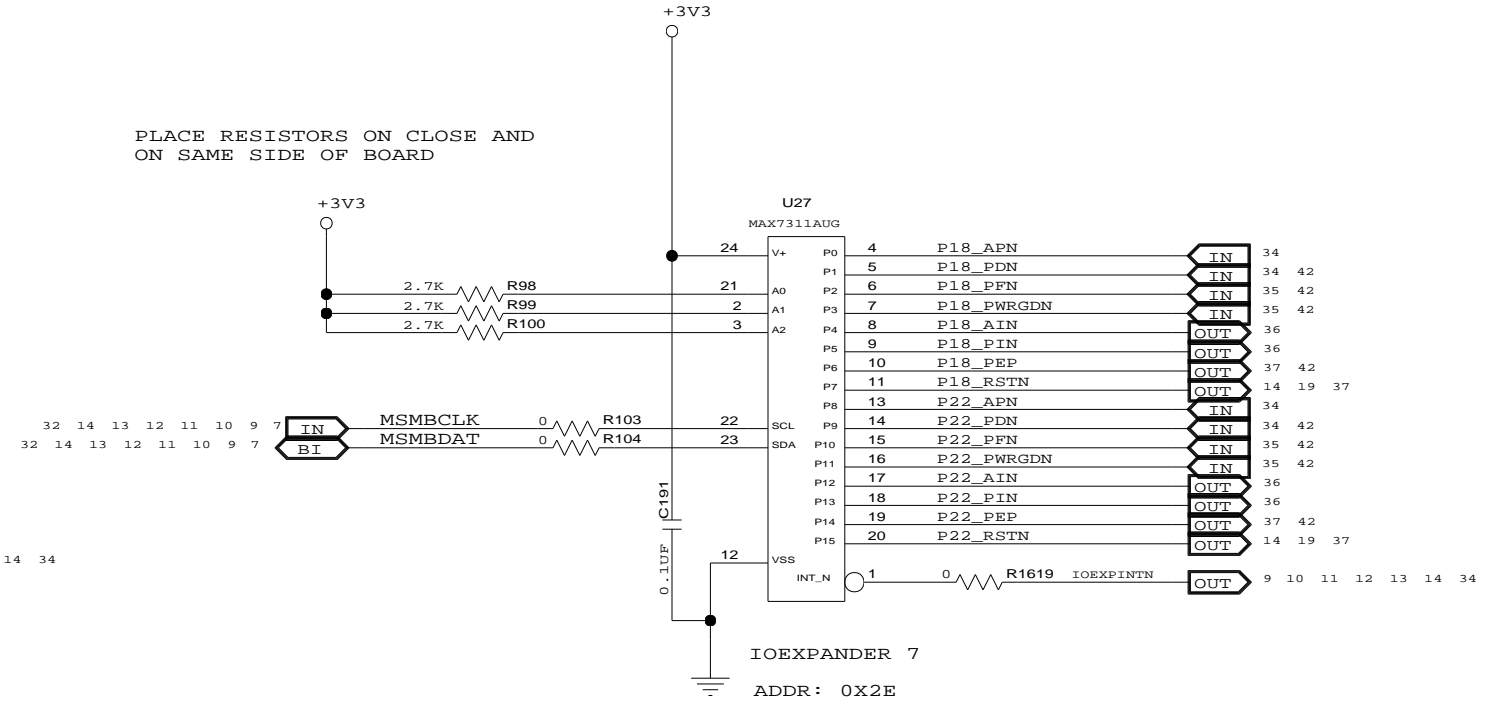

CONFIDENTIAL PROPERTY OF INTEGRATED DEVICE TECHNOLOGY, INC.
6024 SILVER CREEK VALLEY ROAD, SAN JOSE, CA 95138
COPYRIGHT (C) 2010 IDT

TITLE EB-LOGAN-23

IOEXPANDER 4-7

SIZE B	DRAWING NO. SCH-PESEB-001	FAB P/N 18-691-001	REV. 2.0
AUTHOR Tony Tran		CHECKED BY Derek Huang	
Thu Jul 01 15:00:55 2010			SHEET 10 OF 52

PLACE RESISTORS ON CLOSE AND ON SAME SIDE OF BOARD

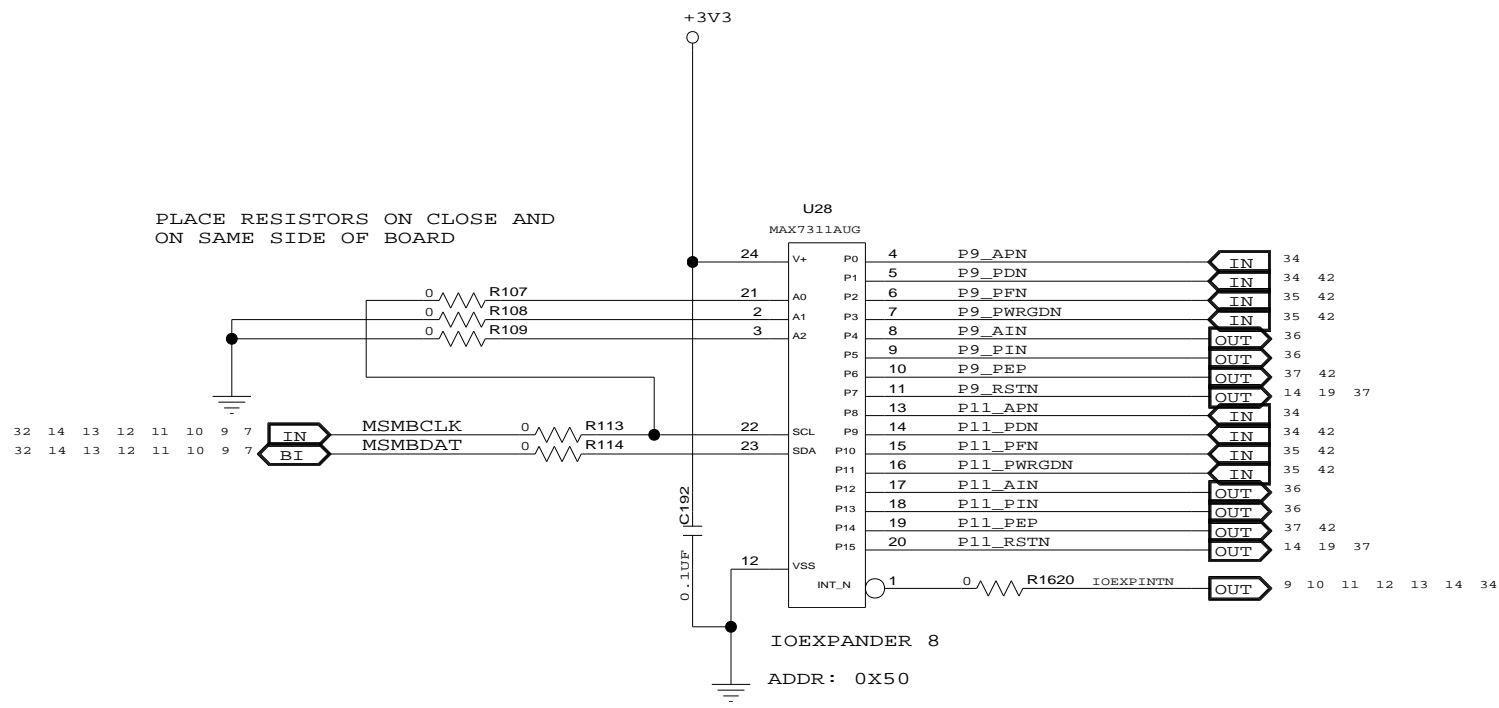

PLACE RESISTORS ON CLOSE AND ON SAME SIDE OF BOARD

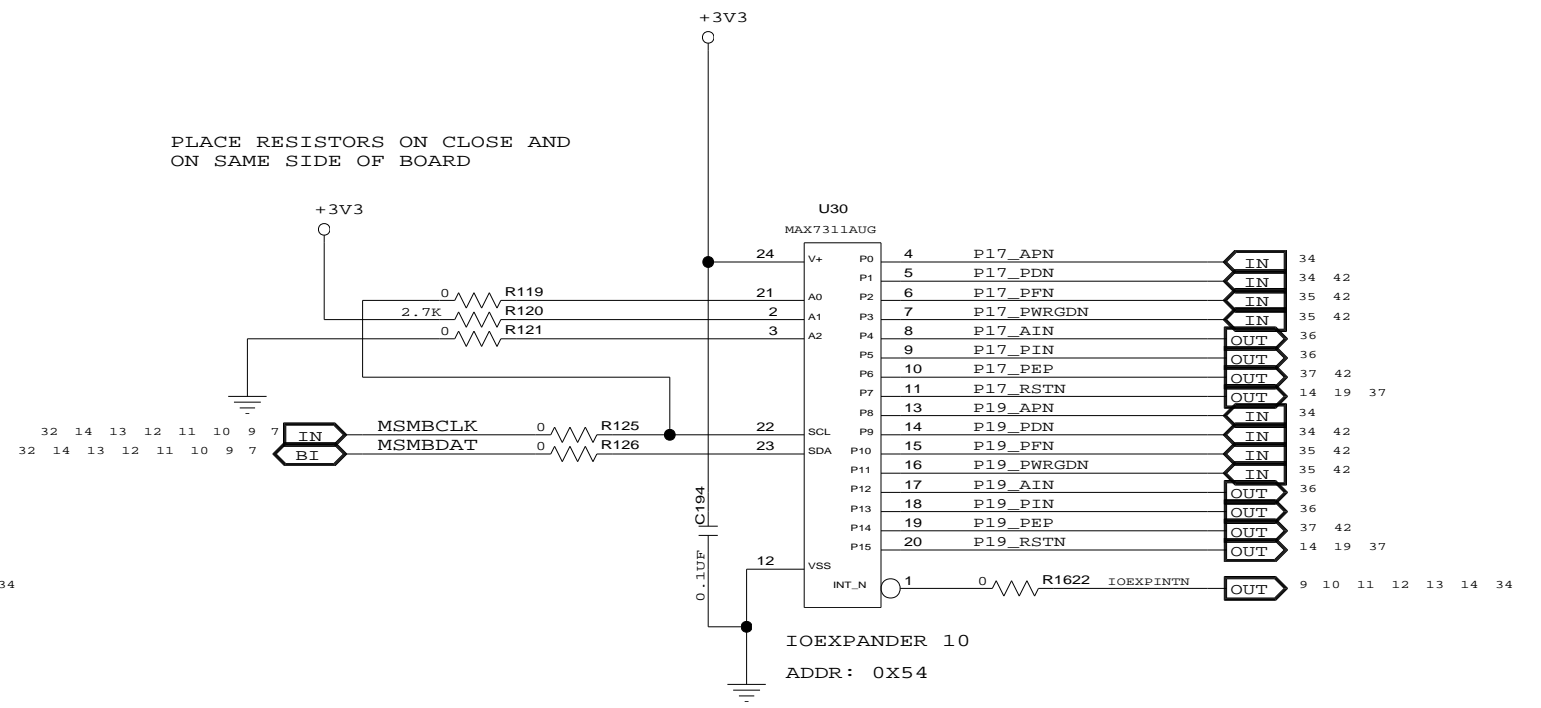

PLACE RESISTORS ON CLOSE AND ON SAME SIDE OF BOARD

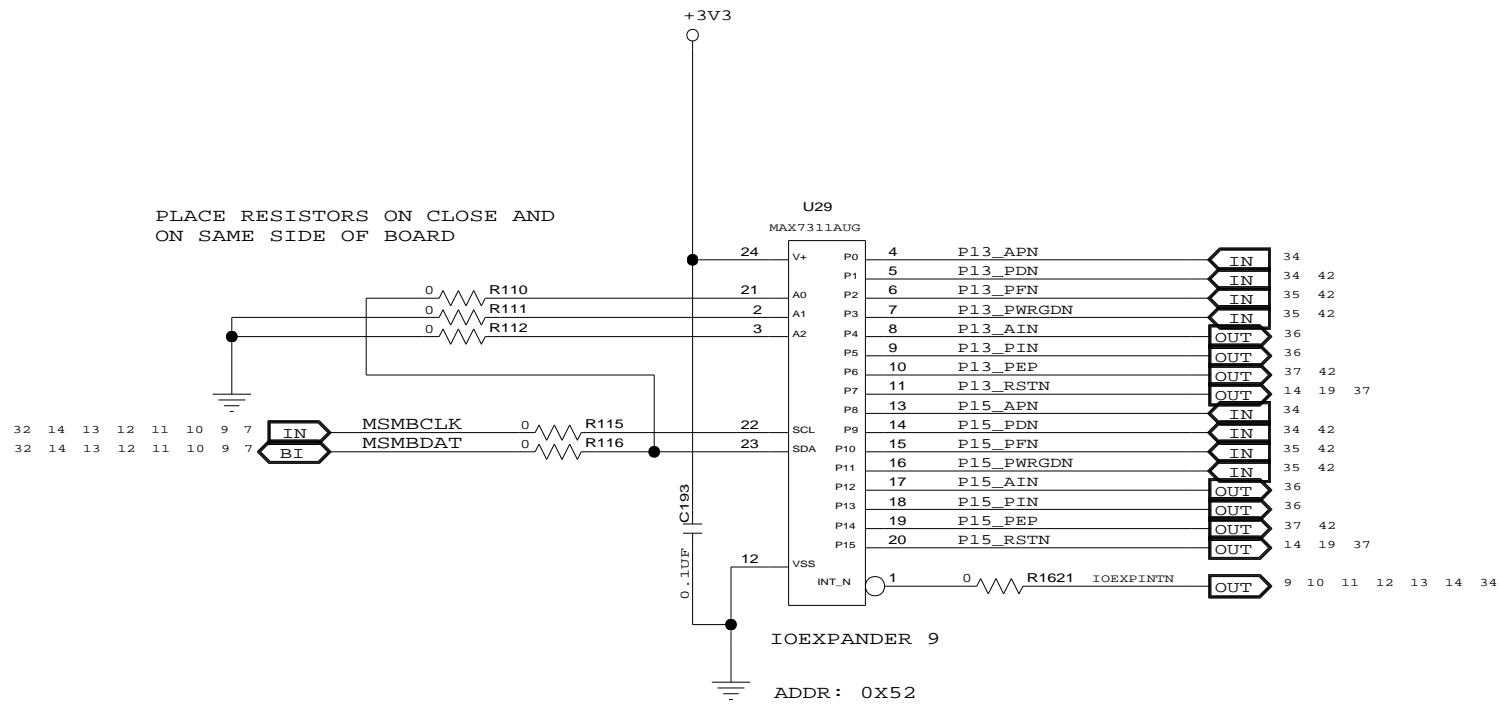

PLACE RESISTORS ON CLOSE AND ON SAME SIDE OF BOARD

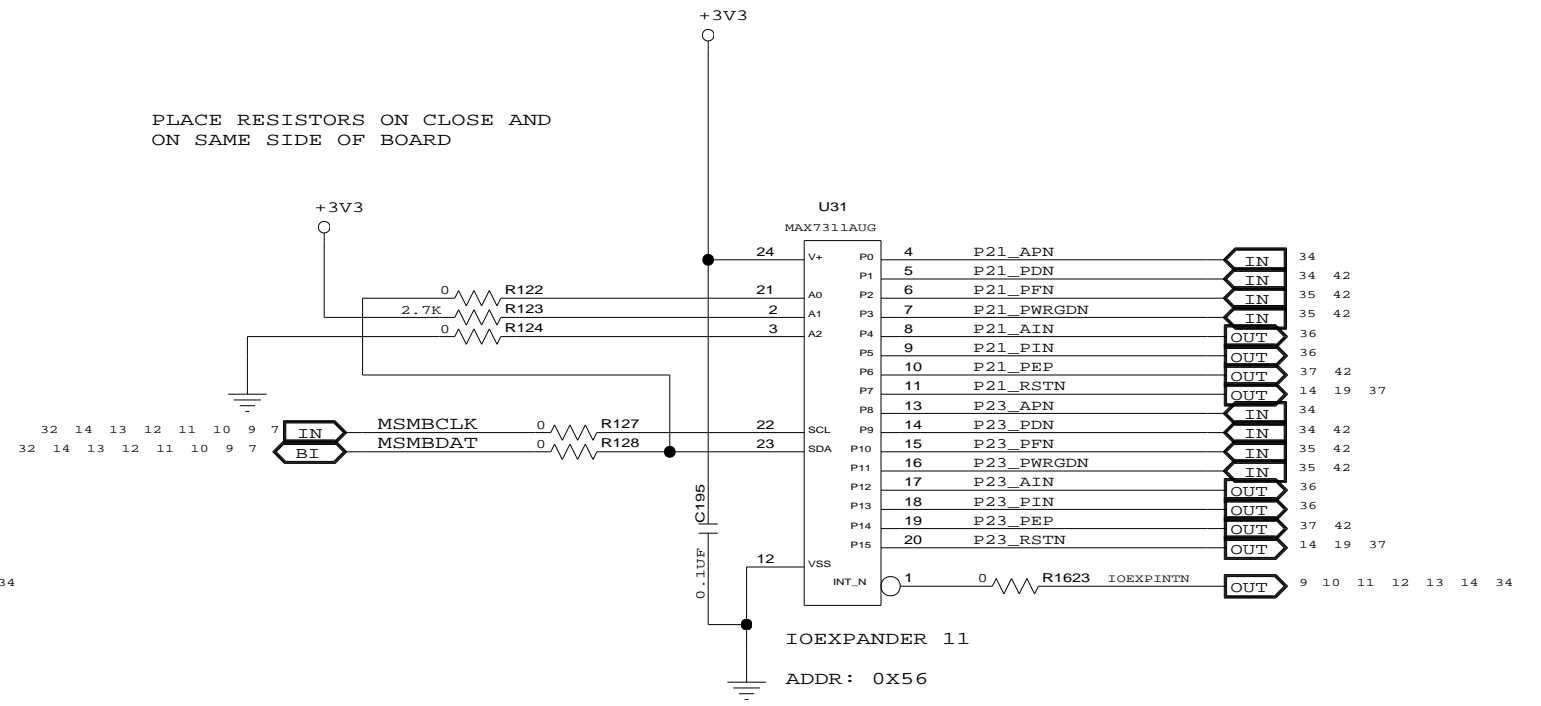

CONFIDENTIAL PROPERTY OF INTEGRATED DEVICE TECHNOLOGY, INC.
6024 SILVER CREEK VALLEY ROAD, SAN JOSE, CA 95138
COPYRIGHT (C) 2009 IDT

TITLE E83a0GWN123ation Board

IOEXPANDER 8-11

SIZE	DRAWING NO.	FAB P/N	REV.
B	SCH-PESEB-001	18-691-001	2.0
AUTHOR		CHECKED BY	
Tony Tran		Derek Huang	
Thu Jul 01 15:00:55 2010			SHEET 11 OF 52

PLACE RESISTORS ON CLOSE AND ON SAME SIDE OF BOARD

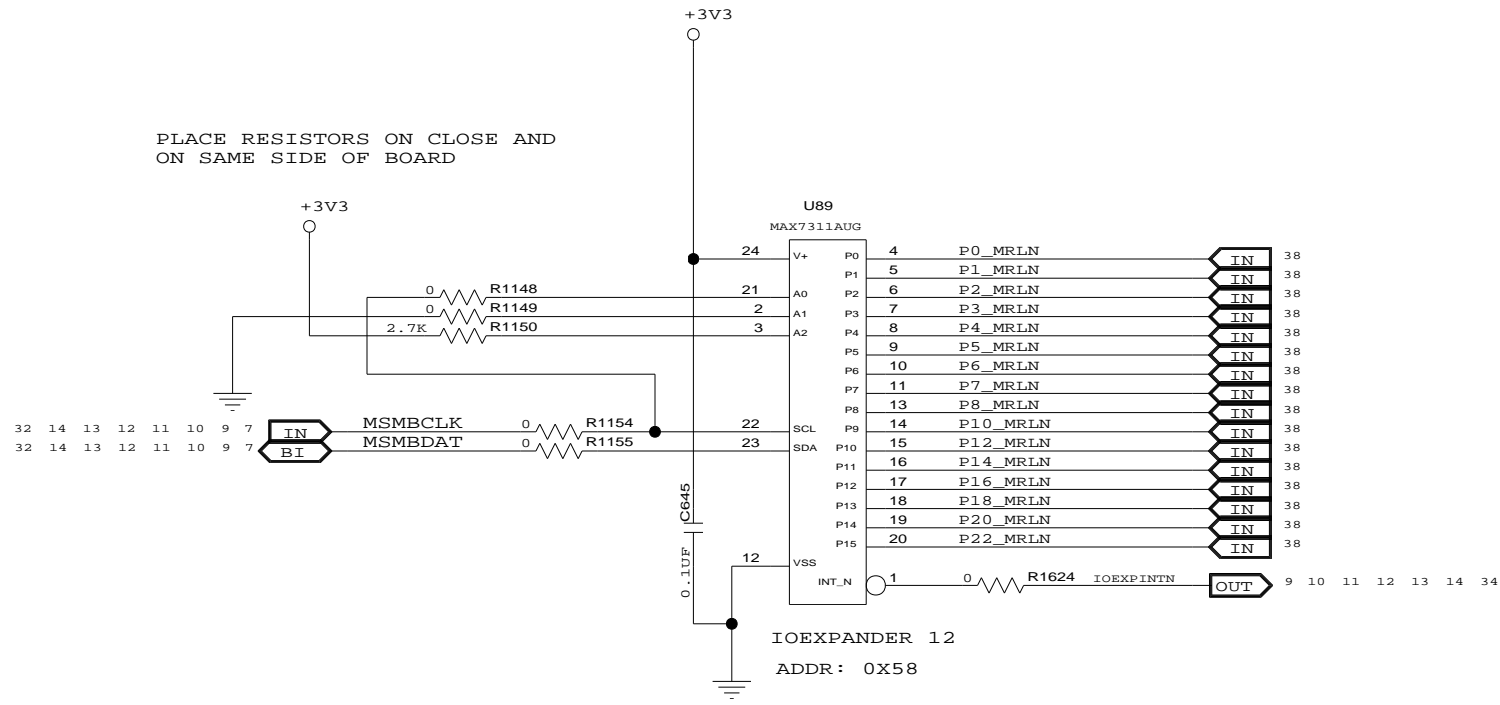

PLACE RESISTORS ON CLOSE AND ON SAME SIDE OF BOARD

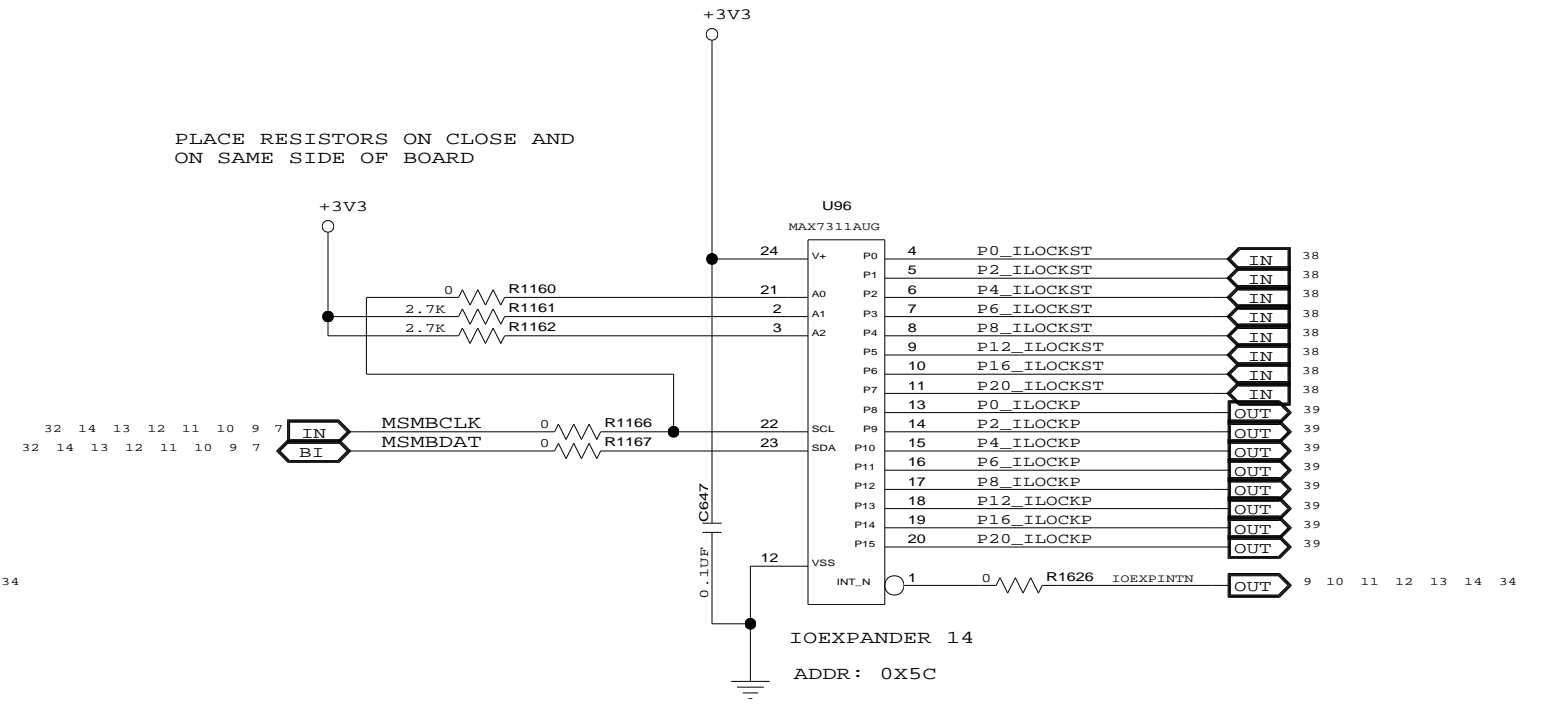

PLACE RESISTORS ON CLOSE AND ON SAME SIDE OF BOARD

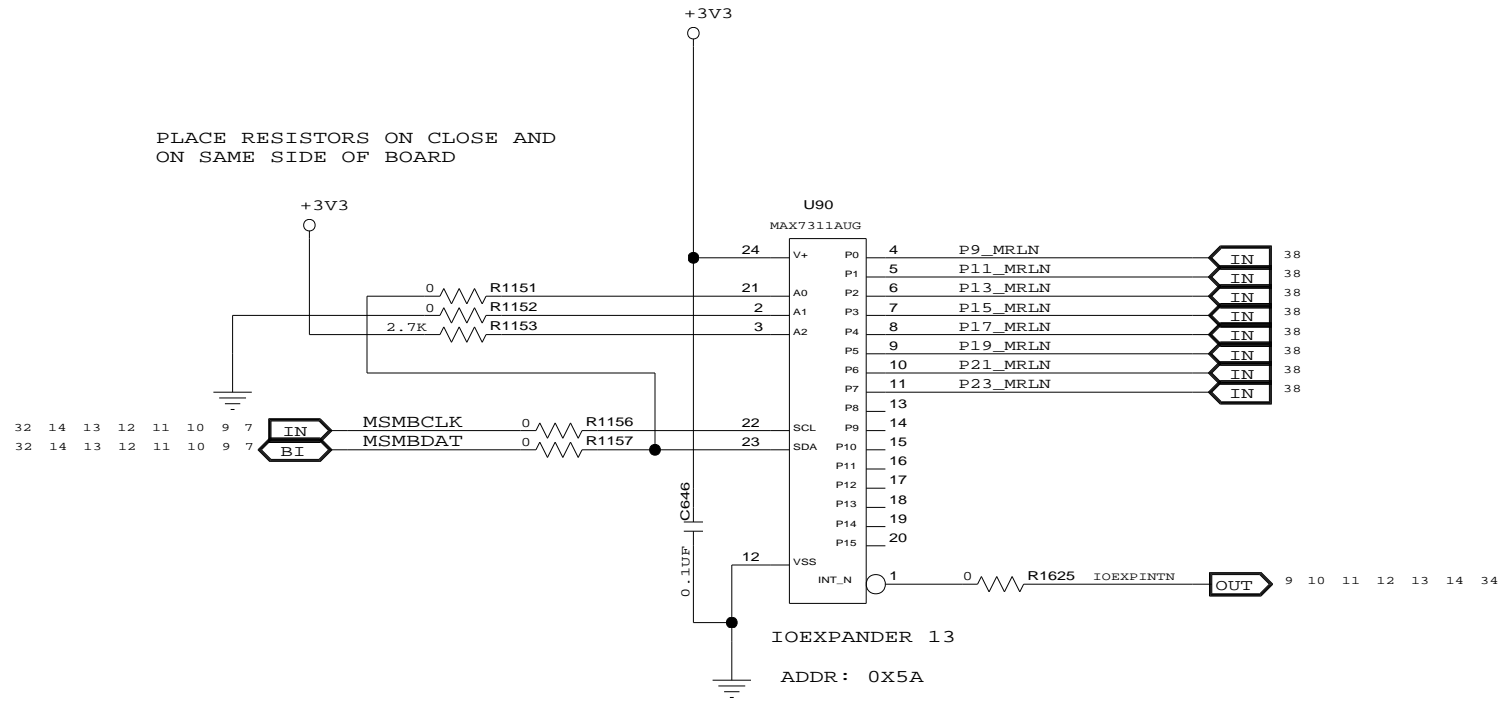

PLACE RESISTORS ON CLOSE AND ON SAME SIDE OF BOARD

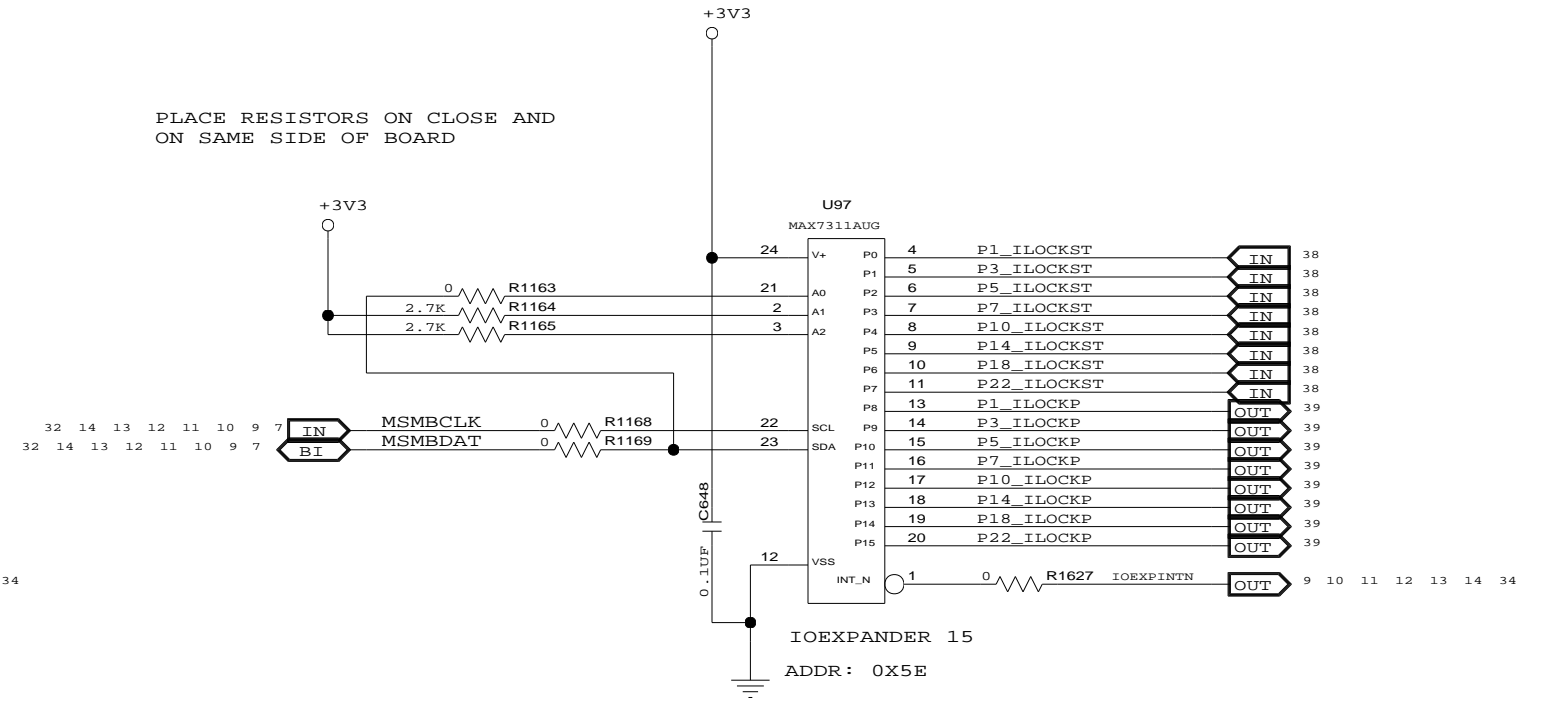



CONFIDENTIAL PROPERTY OF INTEGRATED DEVICE TECHNOLOGY, INC.
6024 SILVER CREEK VALLEY ROAD, SAN JOSE, CA 95138
COPYRIGHT (C) 2010 IDT

TITLE EB-LOGAN-23

IOEXPANDER 12-15

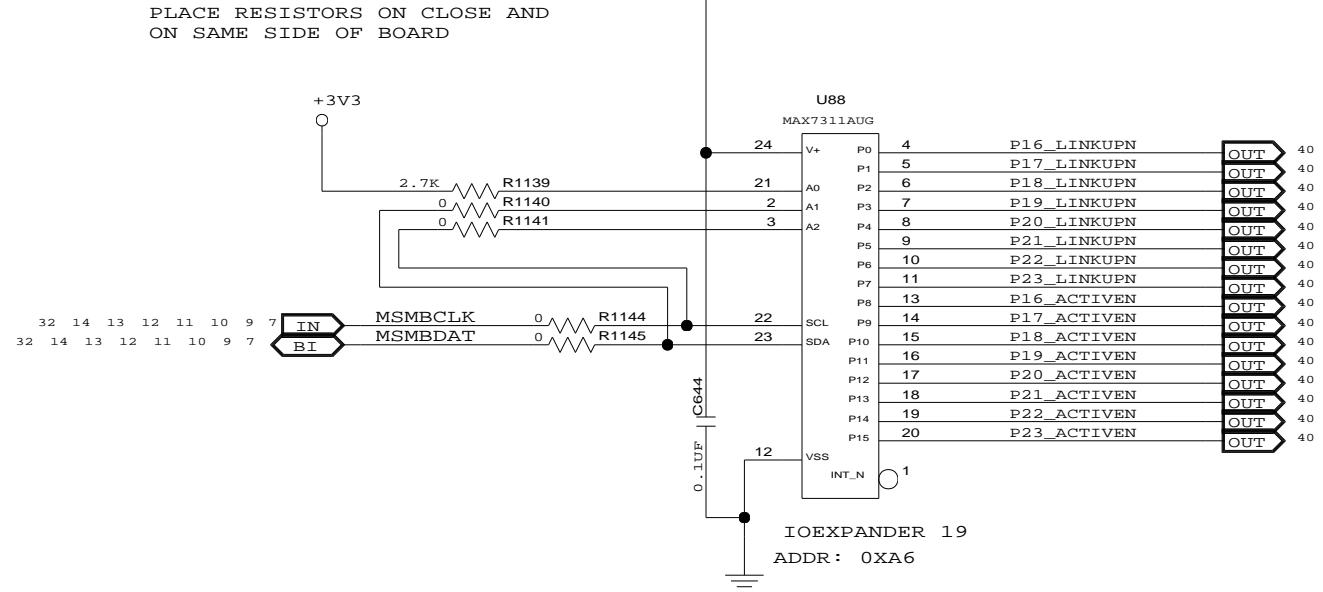
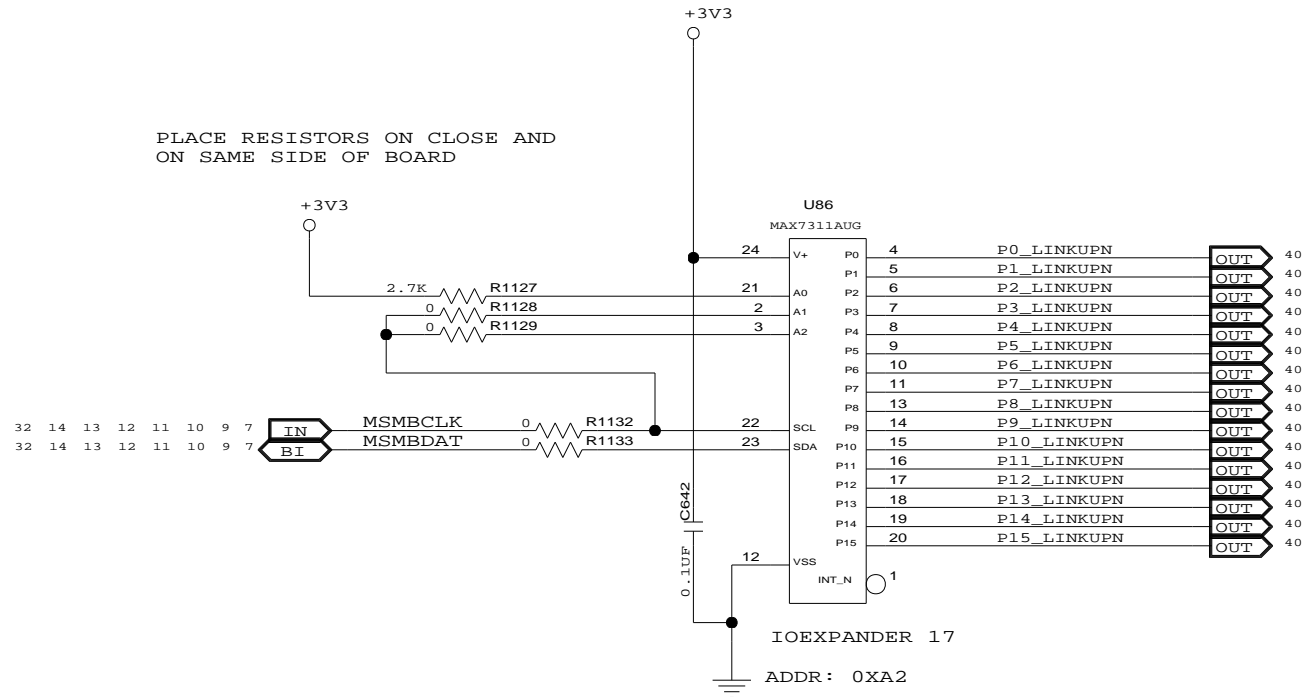
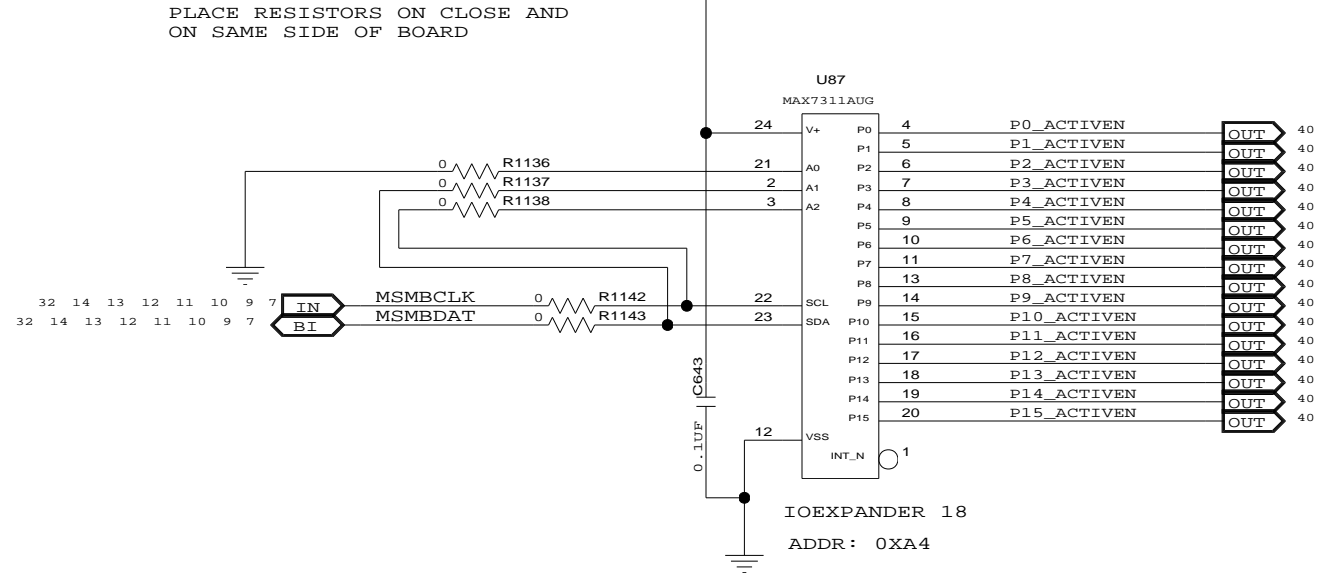
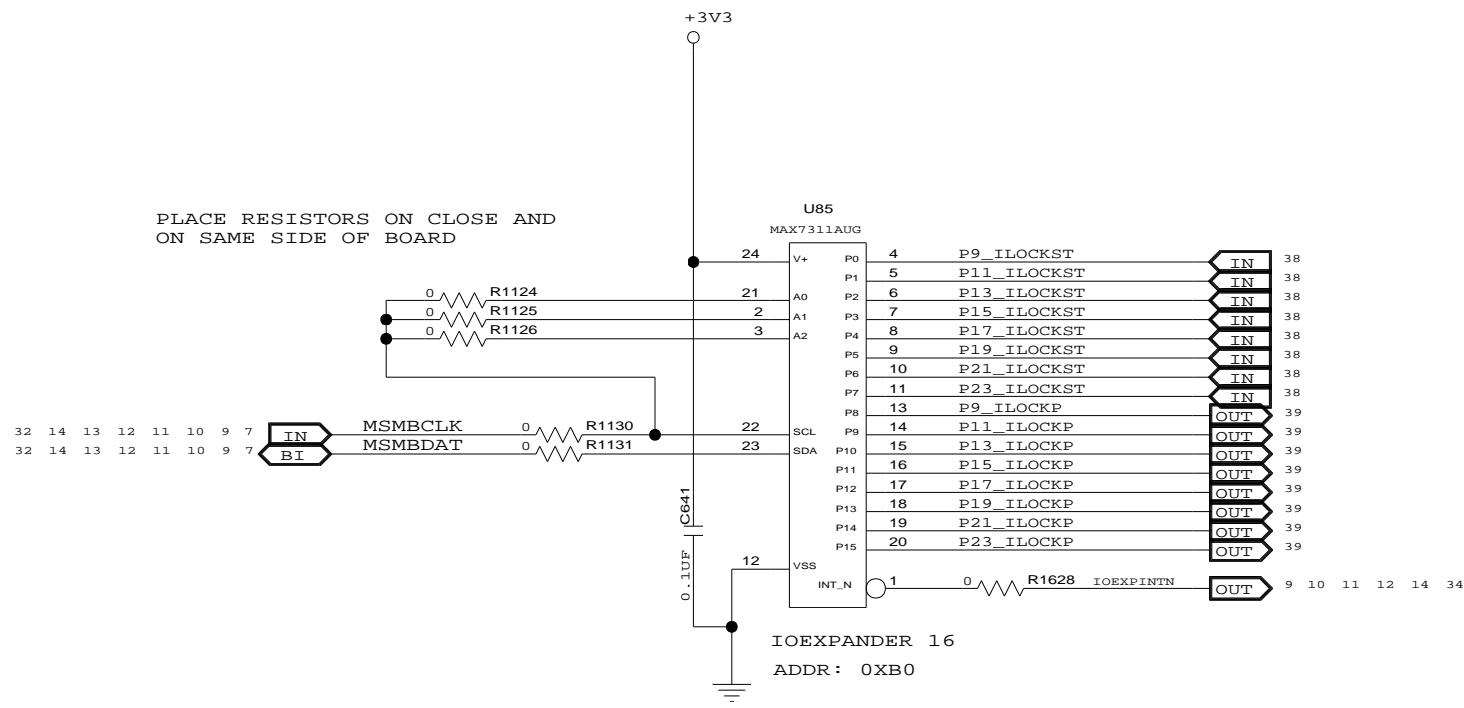
SIZE	DRAWING NO.	FAB P/N	REV.
B	SCH-PESEB-001	18-691-001	2.0
AUTHOR		CHECKED BY	
Tony Tran		Derek Huang	
Thu Jul 01 15:00:55 2010			SHEET 12 OF 52





TITLE EB-LOGAN-23

IOEXPANDER 16-19

SIZE	DRAWING NO.	FAB P/N	REV.
B	SCH-PESEB-001	18-691-001	2.0
AUTHOR		CHECKED BY	
Tony Tran		Derek Huang	
Thu Jul 01 15:00:56 2010			SHEET 13 OF 52

CONFIDENTIAL PROPERTY OF INTEGRATED DEVICE TECHNOLOGY, INC.
6024 SILVER CREEK VALLEY ROAD. SAN JOSE, CA 95138
COPYRIGHT (C) 2010 IDT

PLACE RESISTORS ON CLOSE AND ON SAME SIDE OF BOARD

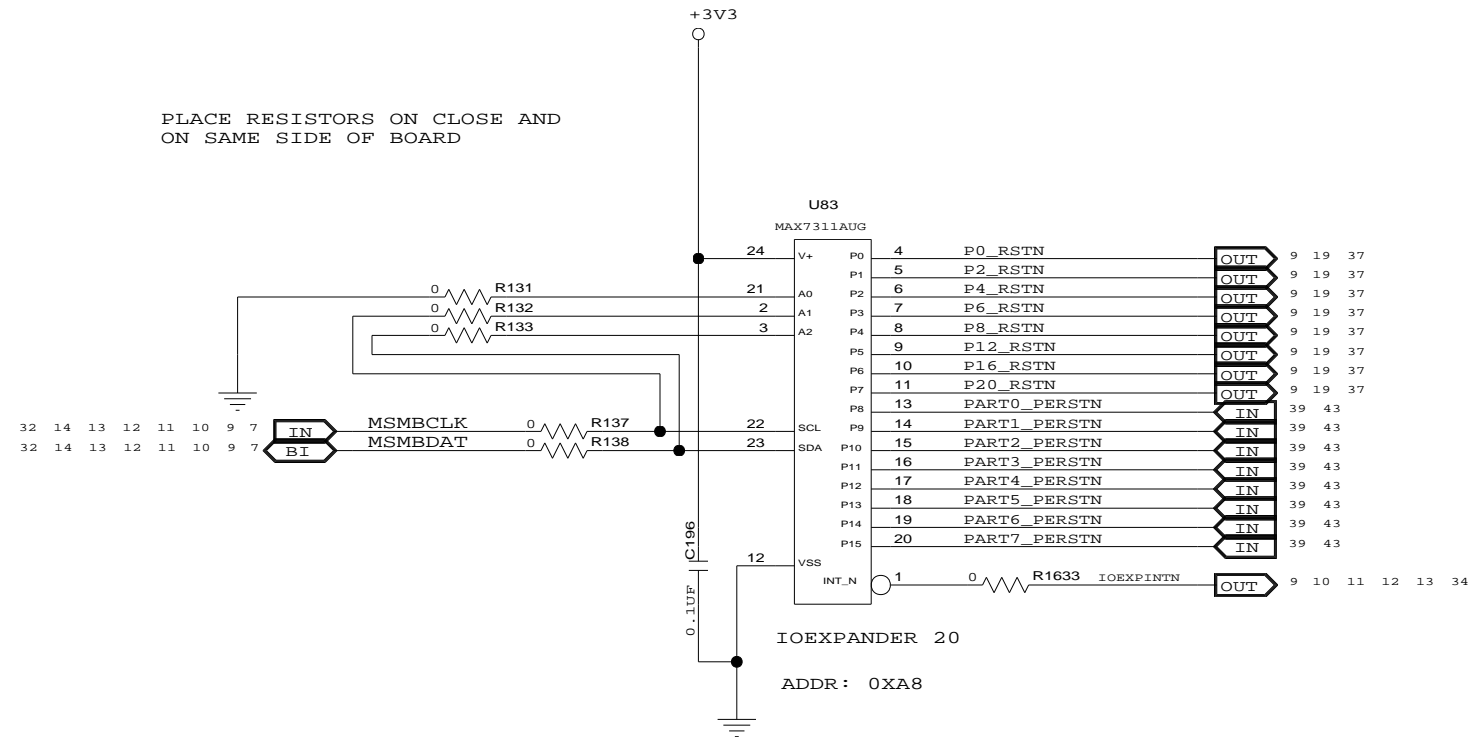

PLACE RESISTORS ON CLOSE AND ON SAME SIDE OF BOARD

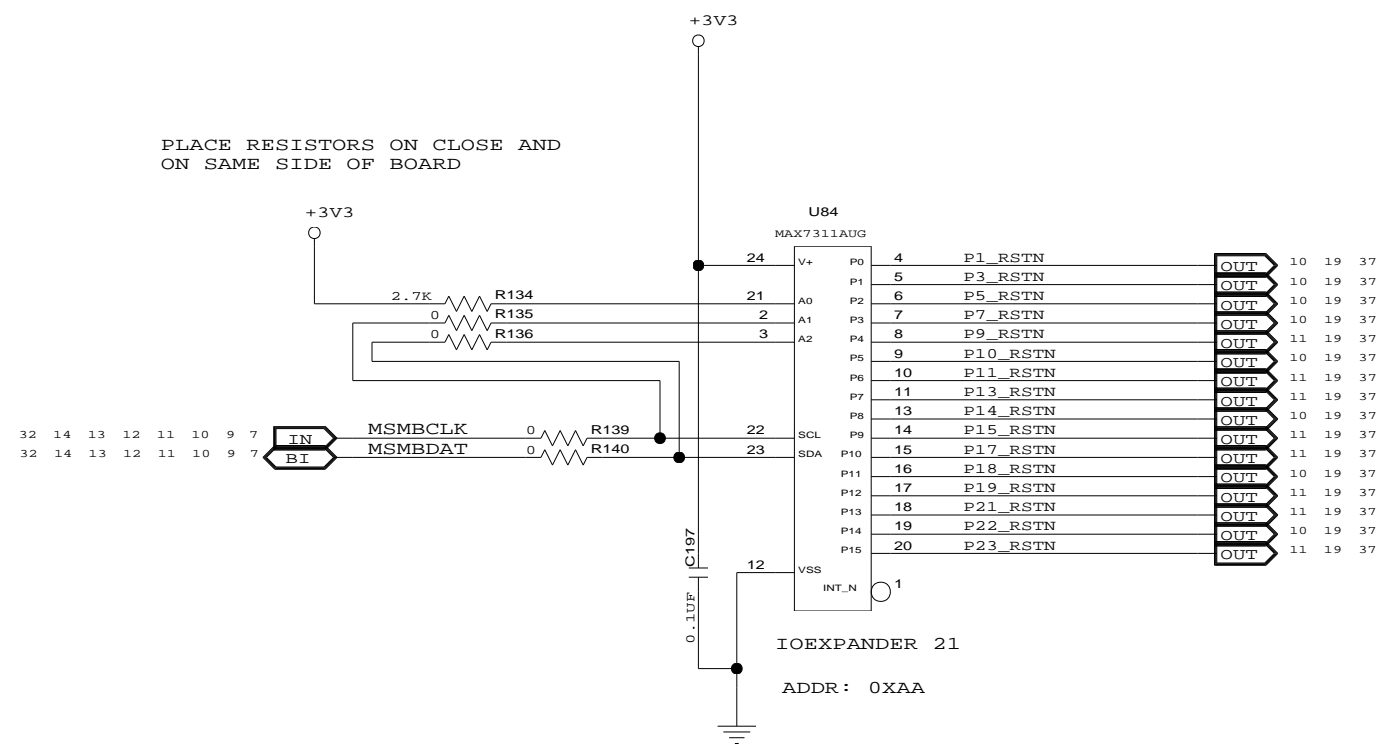

CONFIDENTIAL PROPERTY OF INTEGRATED DEVICE TECHNOLOGY, INC.
6024 SILVER CREEK VALLEY ROAD, SAN JOSE, CA 95138
COPYRIGHT (C) 2010 IDT

TITLE EB-LOGAN-23

IOEXPANDER 20-21

SIZE B	DRAWING NO. SCH-PESEB-001	FAB P/N 18-691-001	REV. 2.0
AUTHOR Tony Tran		CHECKED BY Derek Huang	
Thu Jul 01 15:00:56 2010			SHEET 14 OF 52

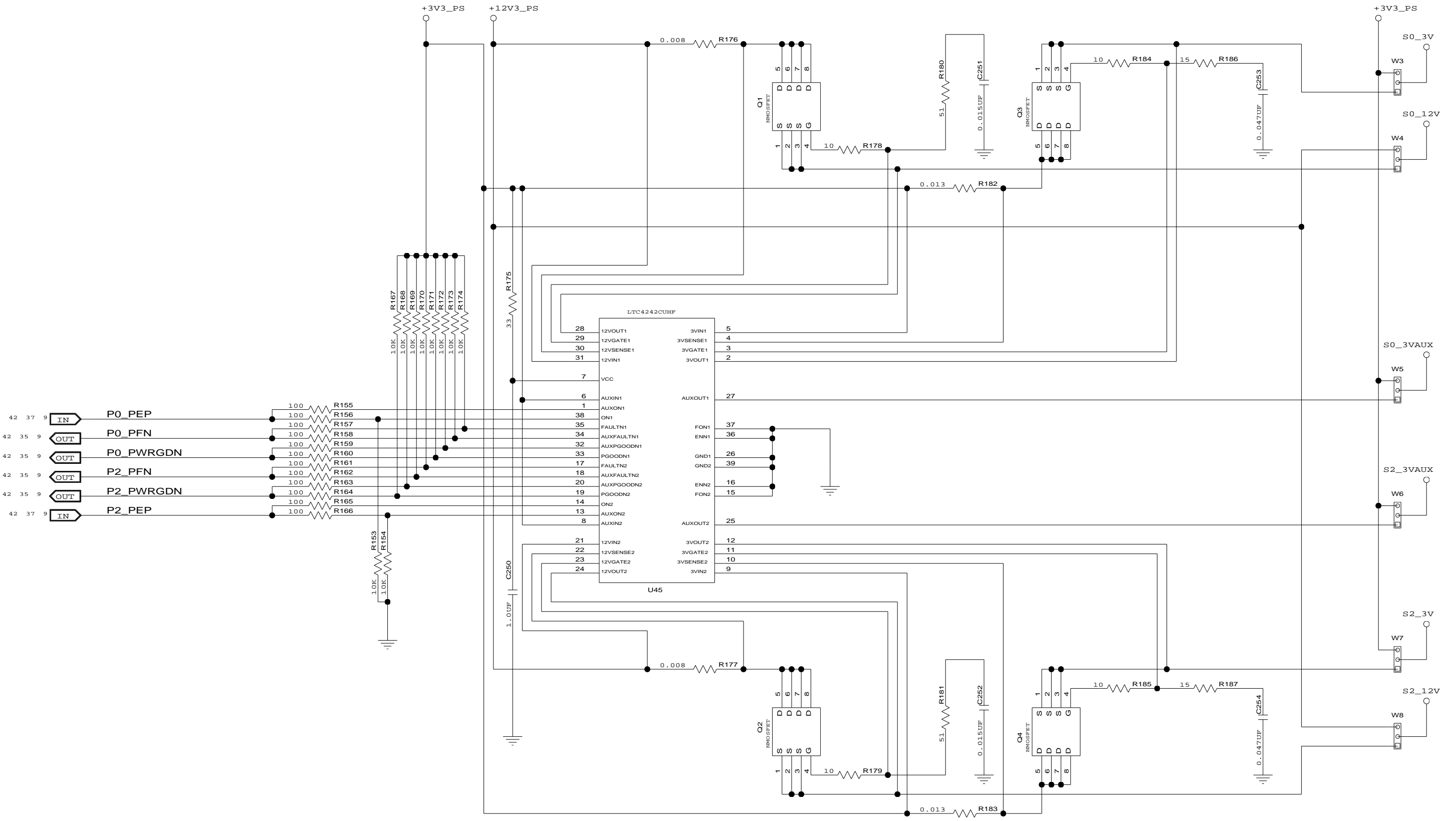

CONFIDENTIAL PROPERTY OF INTEGRATED DEVICE TECHNOLOGY, INC.
6024 SILVER CREEK VALLEY ROAD, SAN JOSE, CA 95138
COPYRIGHT (C) 2010 IDT

TITLE EB-LOGAN-23			
HOT PLUG CONTROL PORTS 0-2			
SIZE B	DRAWING NO. SCH-PESEB-001	FAB P/N 18-691-001	REV. 2.0
AUTHOR Tony Tran		CHECKED BY Derek Huang	
Thu Jul 01 15:00:56 2010			SHEET 15 OF 52

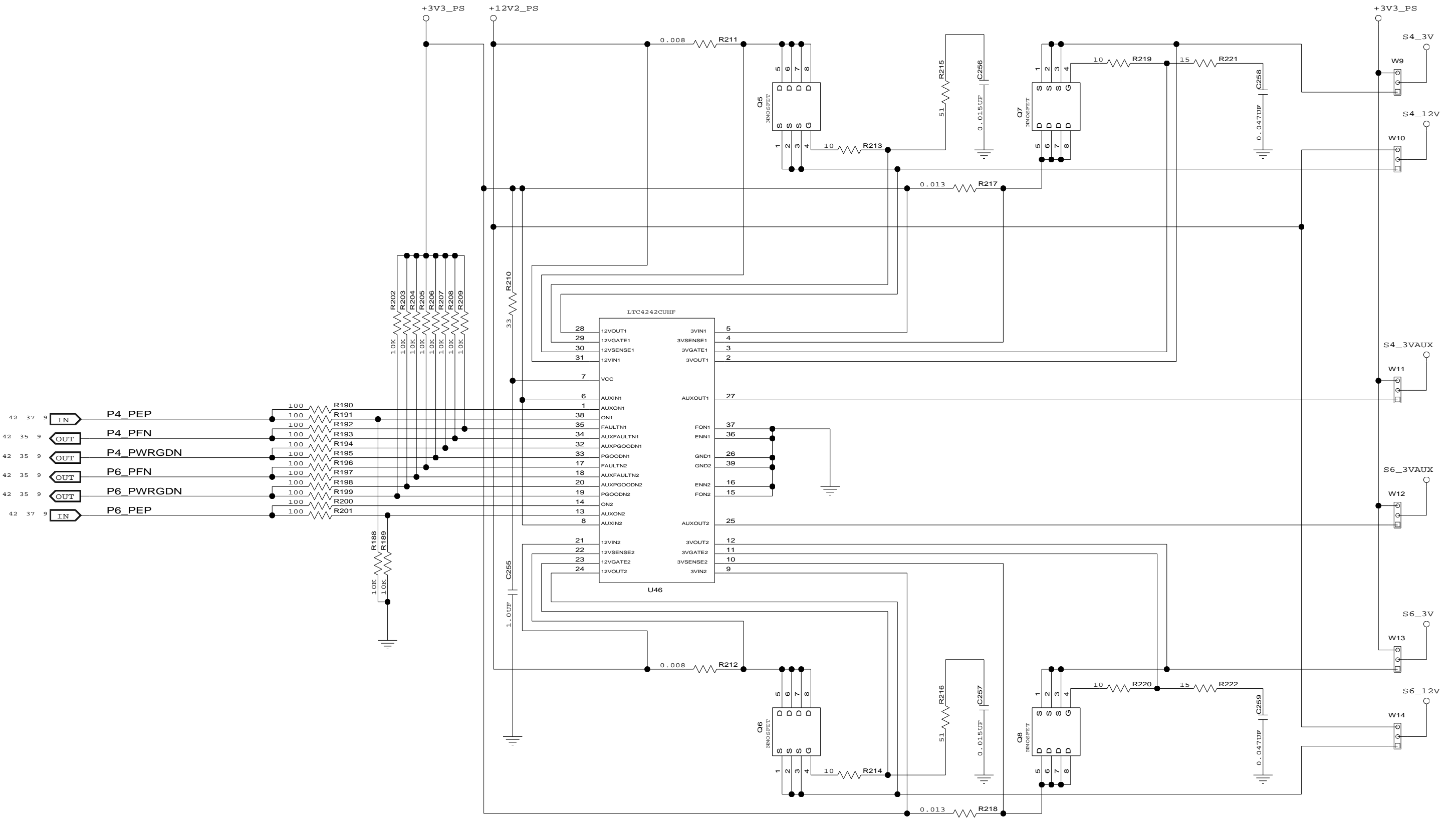

CONFIDENTIAL PROPERTY OF INTEGRATED DEVICE TECHNOLOGY, INC.
6024 SILVER CREEK VALLEY ROAD, SAN JOSE, CA 95138
COPYRIGHT (C) 2010 IDT

TITLE EB-LOGAN-23

HOT PLUG CONTROL PORTS 4-6

SIZE	DRAWING NO.	FAB P/N	REV.
B	SCH-PESEB-001	18-691-001	2.0

AUTHOR	CHECKED BY
Tony Tran	Derek Huang

Thu Jul 01 15:00:57 2010 SHEET 16 OF 52

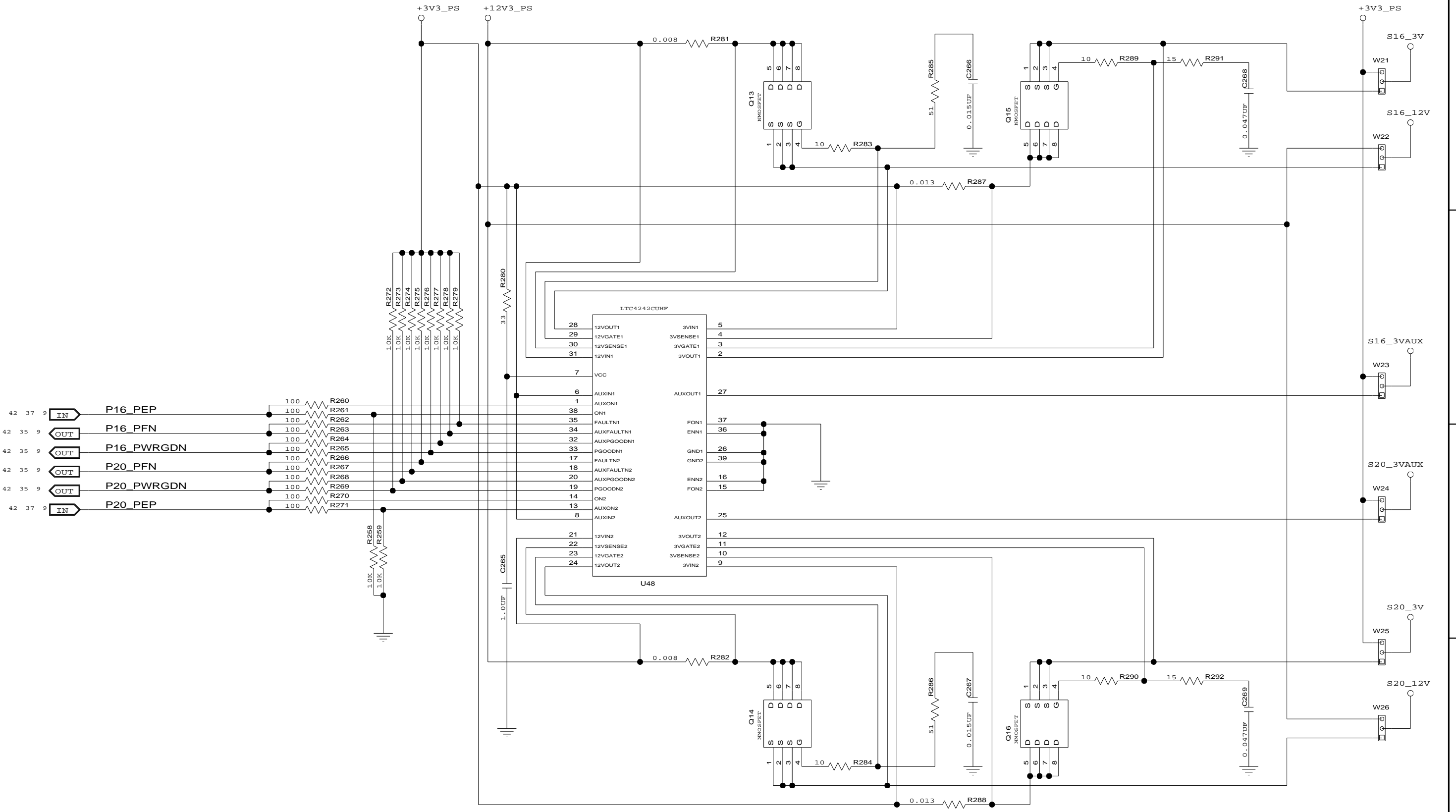

CONFIDENTIAL PROPERTY OF INTEGRATED DEVICE TECHNOLOGY, INC.
6024 SILVER CREEK VALLEY ROAD, SAN JOSE, CA 95138
COPYRIGHT (C) 2010 IDT

TITLE EB-LOGAN-23			
HOT PLUG CONTROL PORTS 16-20			
SIZE B	DRAWING NO. SCH-PESEB-001	FAB P/N 18-691-001	REV. 2.0
AUTHOR Tony Tran		CHECKED BY Derek Huang	
Thu Jul 01 15:00:57 2010			SHEET 18 OF 52

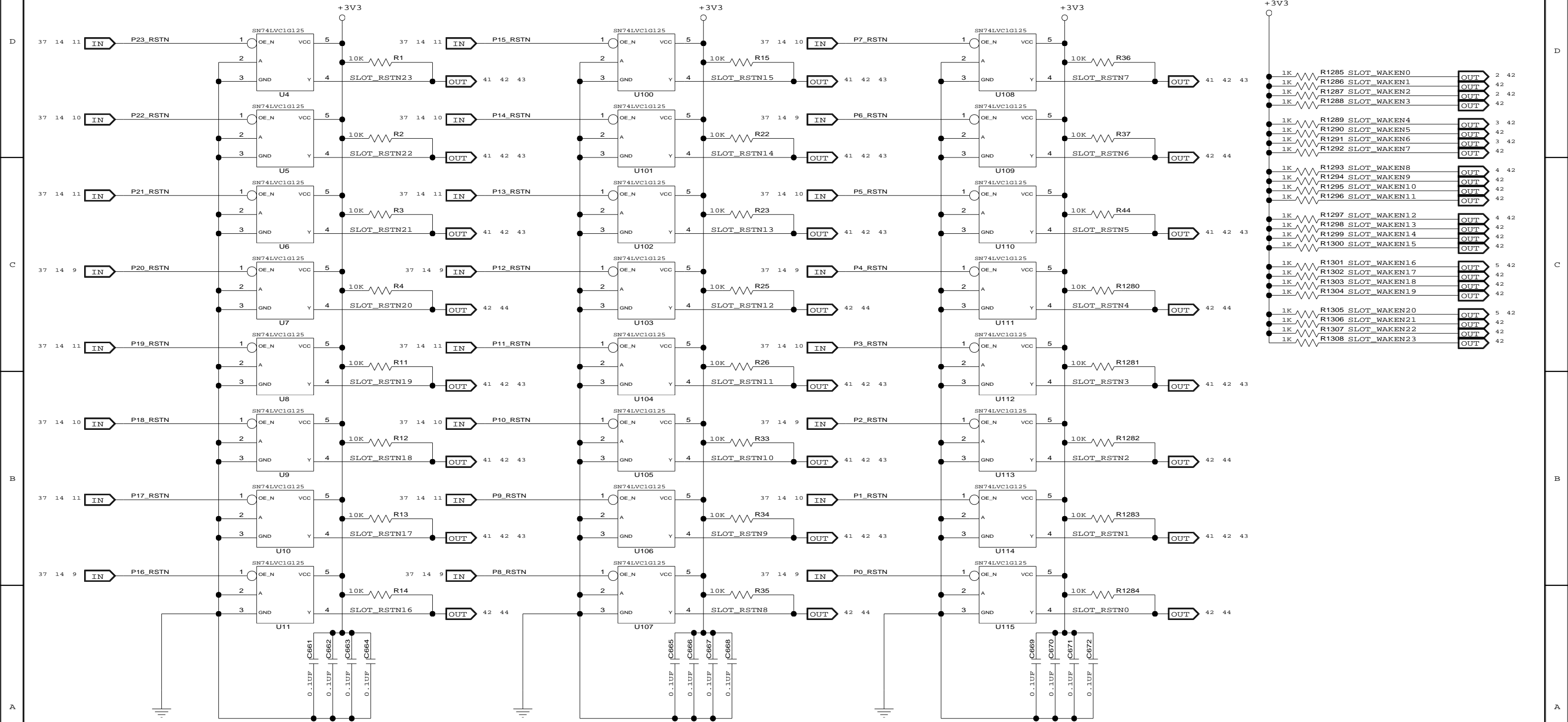

IDT
 CONFIDENTIAL PROPERTY OF INTEGRATED DEVICE TECHNOLOGY, INC.
 6024 SILVER CREEK VALLEY ROAD, SAN JOSE, CA 95138
 COPYRIGHT (C) 2010 IDT

TITLE EB-LOGAN-23			
SLOT RESETS AND WAKE PULL-UPS			
SIZE	DRAWING NO.	FAB P/N	REV.
B	SCH-PESEB-001	18-691-001	2.0
AUTHOR		CHECKED BY	
Tony Tran		Derek Huang	
Thu Jul 01 15:00:57 2010			SHEET 19 OF 52

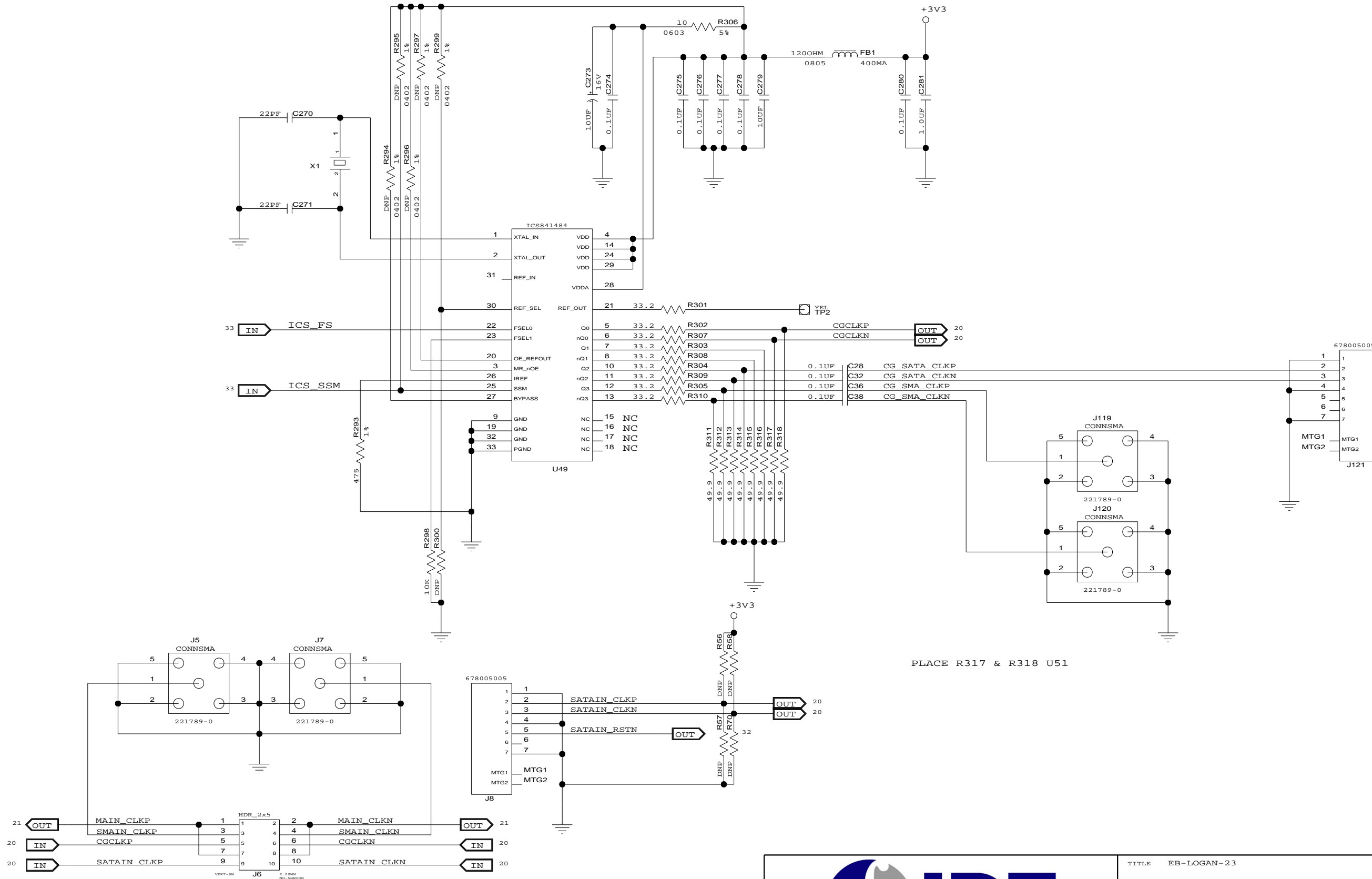



IDT™

CONFIDENTIAL PROPERTY OF INTEGRATED DEVICE TECHNOLOGY, INC.
6024 SILVER CREEK VALLEY ROAD, SAN JOSE, CA 95138
COPYRIGHT (C) 2010 IDT

TITLE EB-LOGAN-23			
CLOCK			
SIZE B	DRAWING NO. SCH-PESEB-001	FAB P/N 18-691-001	REV. 2.0
AUTHOR Tony Tran		CHECKED BY Derek Huang	
Thu Jul 01 15:00:58 2010			SHEET 20 OF 52

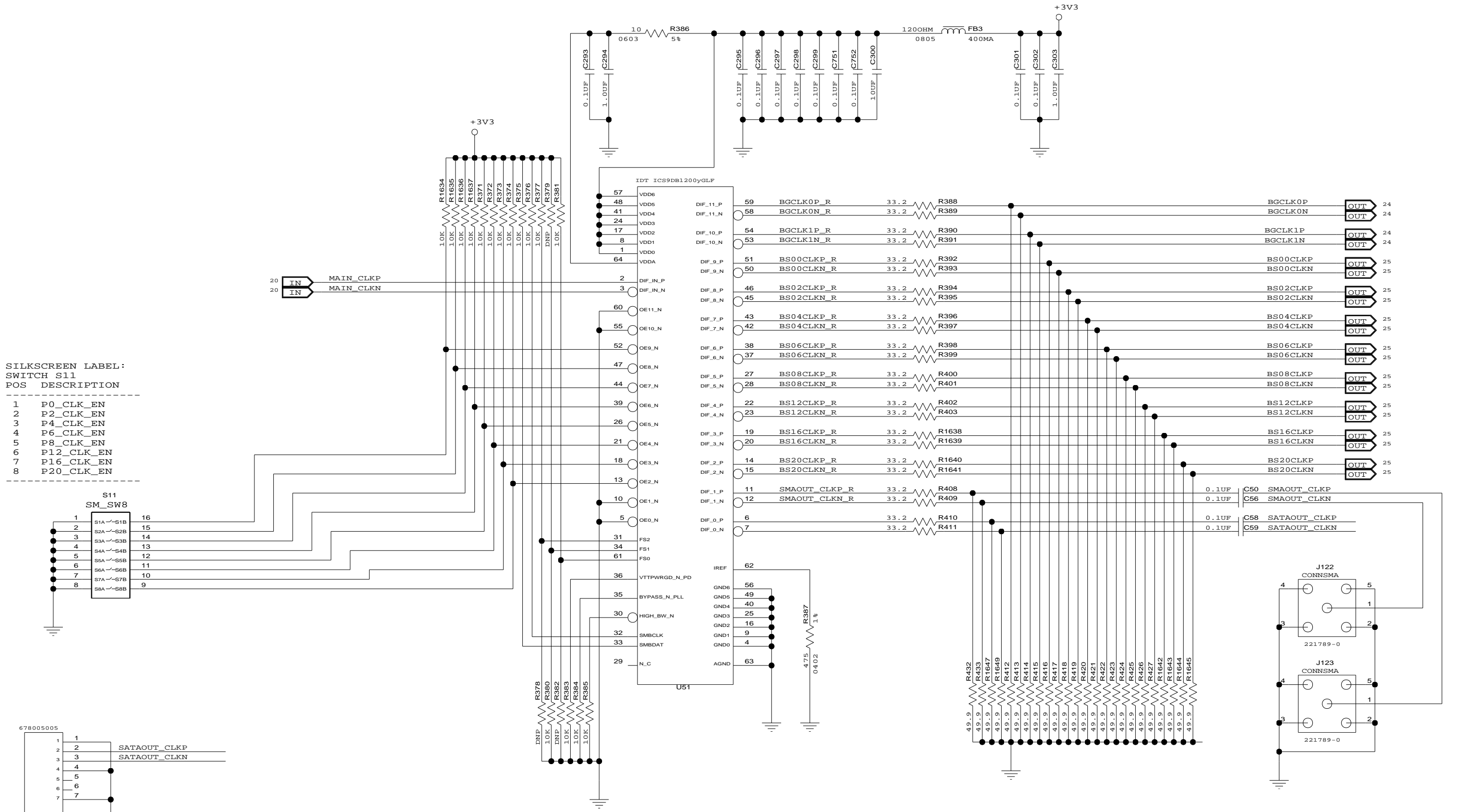

SILKSCREEN LABEL:
SWITCH S11

POS	DESCRIPTION
1	P0_CLK_EN
2	P2_CLK_EN
3	P4_CLK_EN
4	P6_CLK_EN
5	P8_CLK_EN
6	P12_CLK_EN
7	P16_CLK_EN
8	P20_CLK_EN

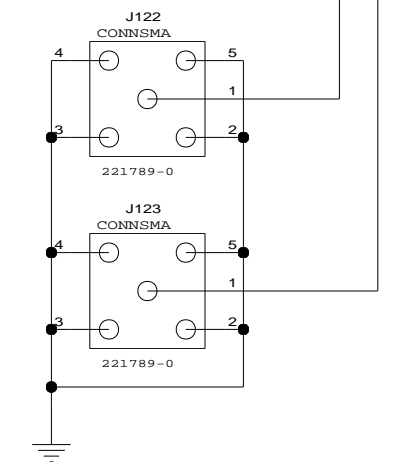
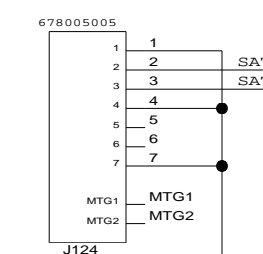
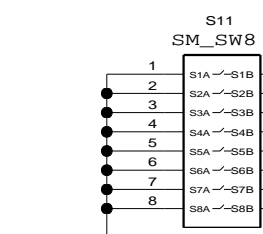



CONFIDENTIAL PROPERTY OF INTEGRATED DEVICE TECHNOLOGY, INC.
6024 SILVER CREEK VALLEY ROAD, SAN JOSE, CA 95138
COPYRIGHT (C) 2010 IDT

TITLE EB-LOGAN-23

CLOCK BUFFER - 1

SIZE	DRAWING NO.	FAB P/N	REV.
B	SCH-PESEB-001	18-691-001	2.0
AUTHOR		CHECKED BY	
Tony Tran		Derek Huang	

Thu Jul 01 15:00:58 2010

P8CLK - DUT PORT 8 CLK
 LP8CLK - LOCAL CLOCK GEN. PORT 8 CLK
 P8SHXCLK - TO SLOT CLK HEADERS

PLACE 470 AND 56 OHM RESISTORS CLOSE TO DESTINATION.

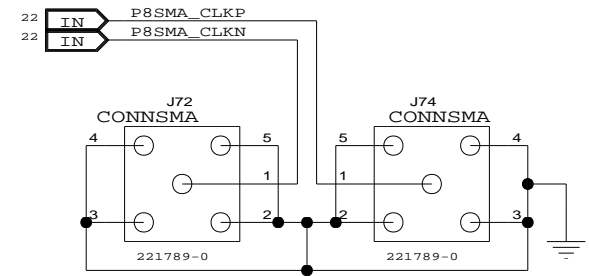
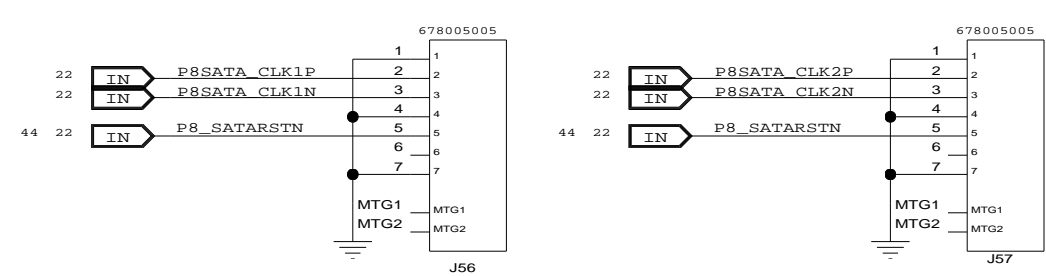
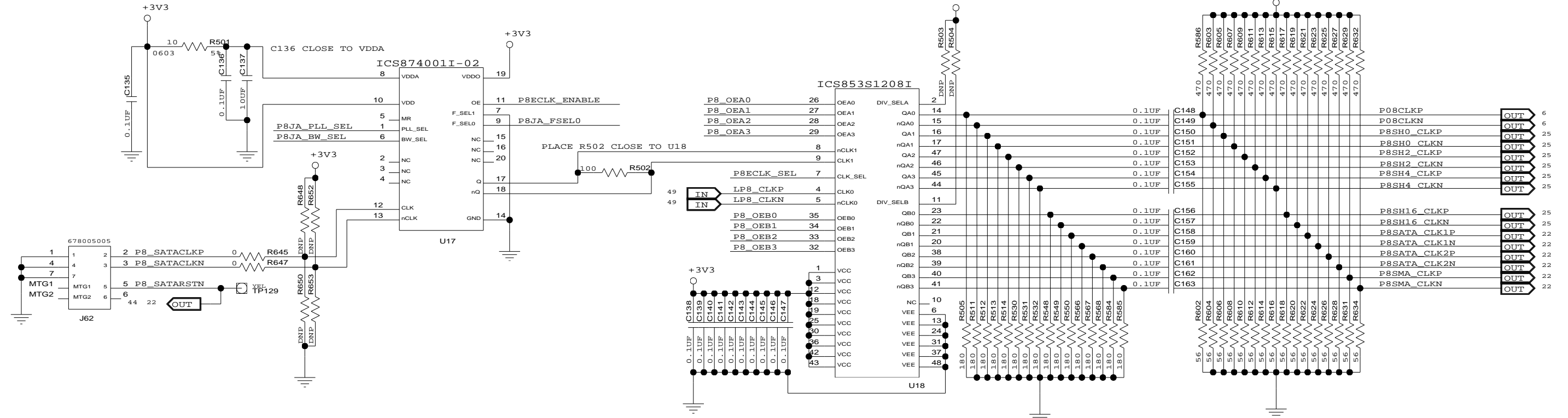

DEFAULT DIPSW SETTING
 S19:1 OFF (SATACLK)
 S19:3 OFF (PLL)
 S19:4 OFF (2.2MHZ)
 S19:5 OFF (U17 OUTPUT ON)
 S19:6 ON (100MHZ)

U18 OUTPUTS
 OFF (ENABLE)
 ON (DISABLE)

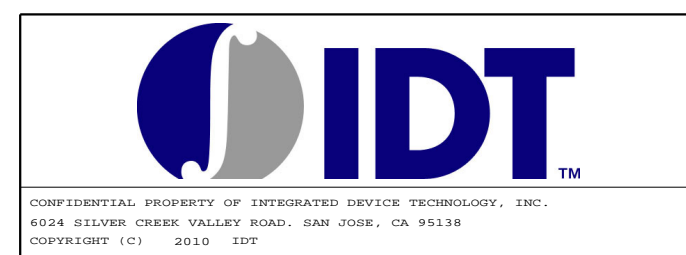
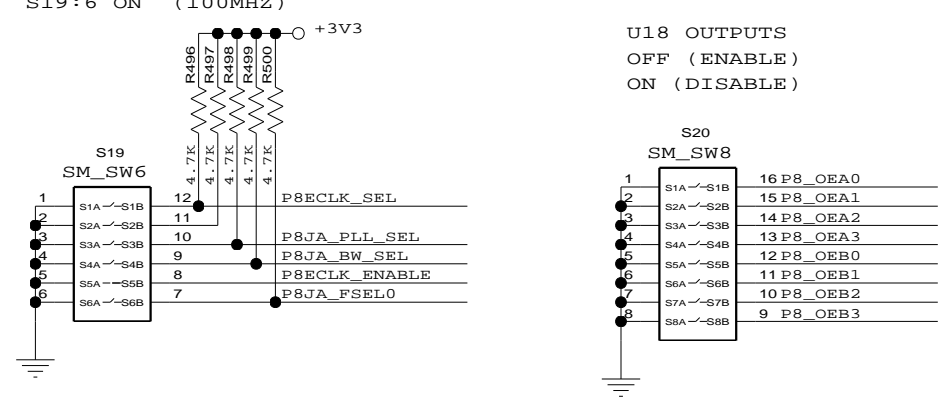

TITLE EB-LOGAN-23			
CLOCK SELECTOR DUT PCLK 8			
SIZE B	DRAWING NO. SCH-PESEB-001	FAB P/N 18-691-001	REV. 2.0
AUTHOR Tony Tran		CHECKED BY Derek Huang	
Tue Aug 10 13:51:12 2010			SHEET 22 OF 52

P16CLK - DUT PORT 16 CLK
 LP16CLK - LOCAL CLOCK GEN. PORT 16 CLK
 P16SHXCLK - TO SLOT CLK HEADERS

PLACE 470 AND 56 OHM RESISTORS CLOSE TO DESTINATION.

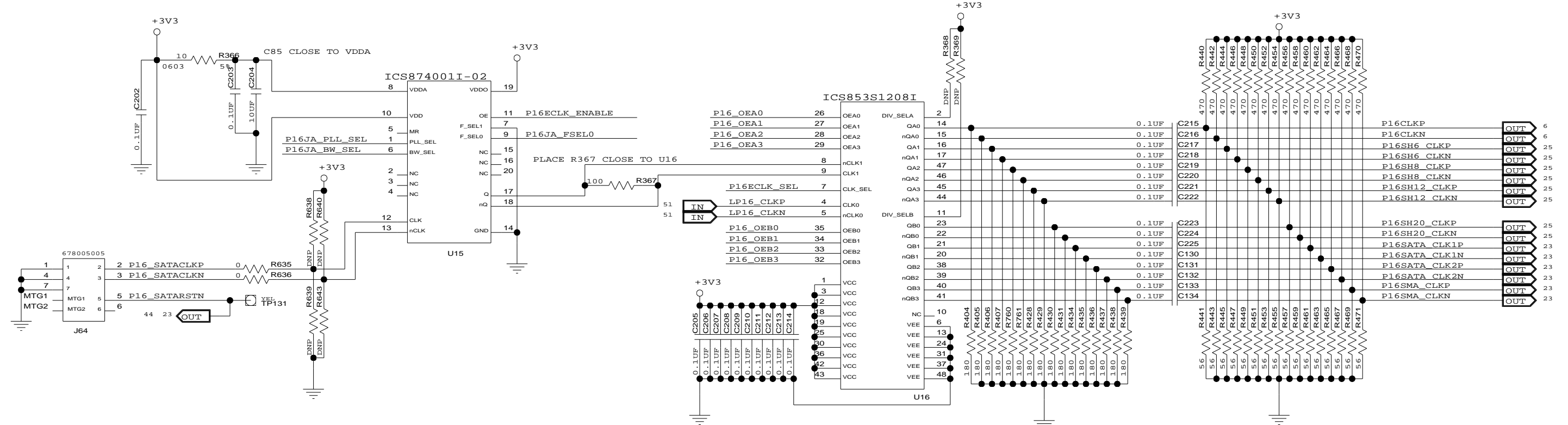

DEFAULT DIPSW SETTING

- S17:1 OFF (SATACLK)
- S17:3 OFF (PLL)
- S17:4 OFF (2.2MHZ)
- S17:5 OFF (U15 OUTPUT ON)
- S17:6 ON (100MHZ)

U16 OUTPUTS
 OFF (ENABLE)
 ON (DISABLE)

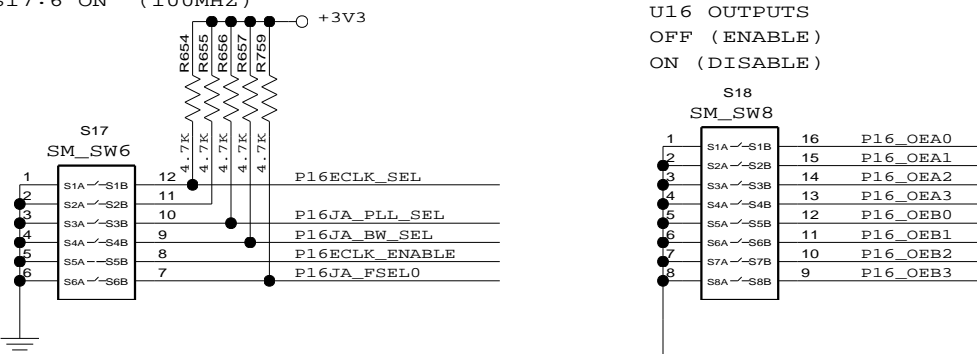

CONFIDENTIAL PROPERTY OF INTEGRATED DEVICE TECHNOLOGY, INC.
 6024 SILVER CREEK VALLEY ROAD, SAN JOSE, CA 95138
 COPYRIGHT (C) 2010 IDT

TITLE EB-LOGAN-23

CLOCK SELECTOR DUT PCLK 16

SIZE	DRAWING NO.	FAB P/N	REV.
B	SCH-PESEB-001	18-691-001	2.0
AUTHOR		CHECKED BY	
Tony Tran		Derek Huang	
Tue Aug 10 13:51:21 2010			SHEET 23 OF 52

EXCLK - DUT CLK
 LPXXCLK - LOCAL CLOCK GEN. PORT CLK
 SHXXCLK - SLOT HDR. CLK

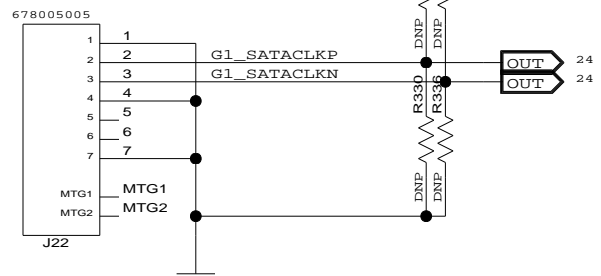
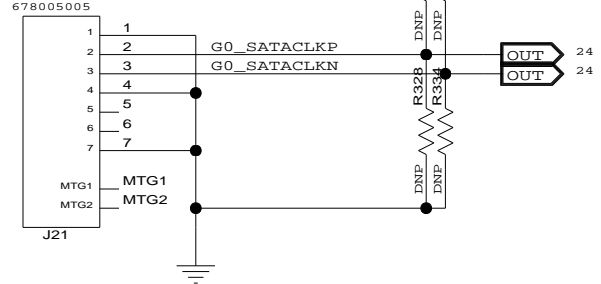
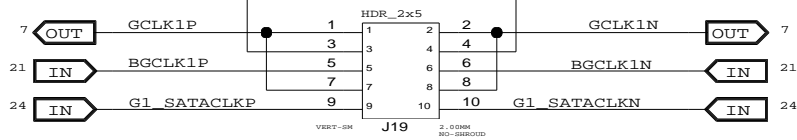
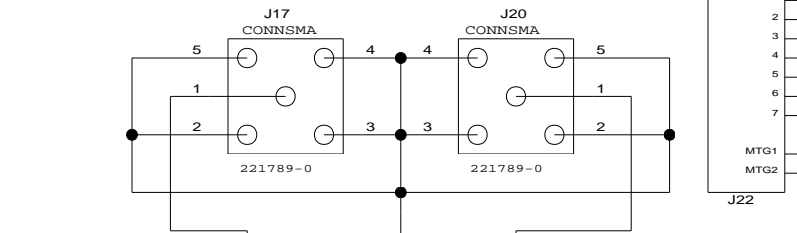
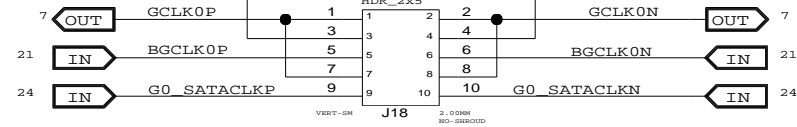
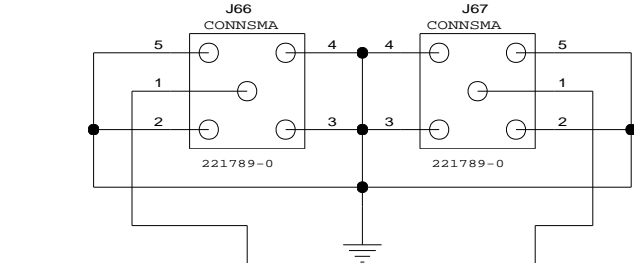
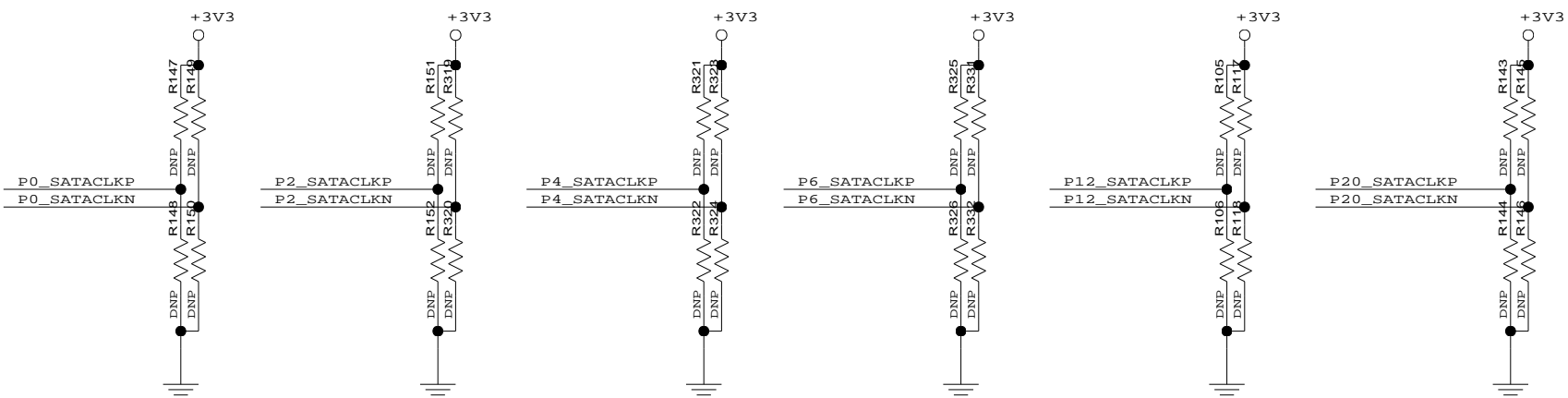
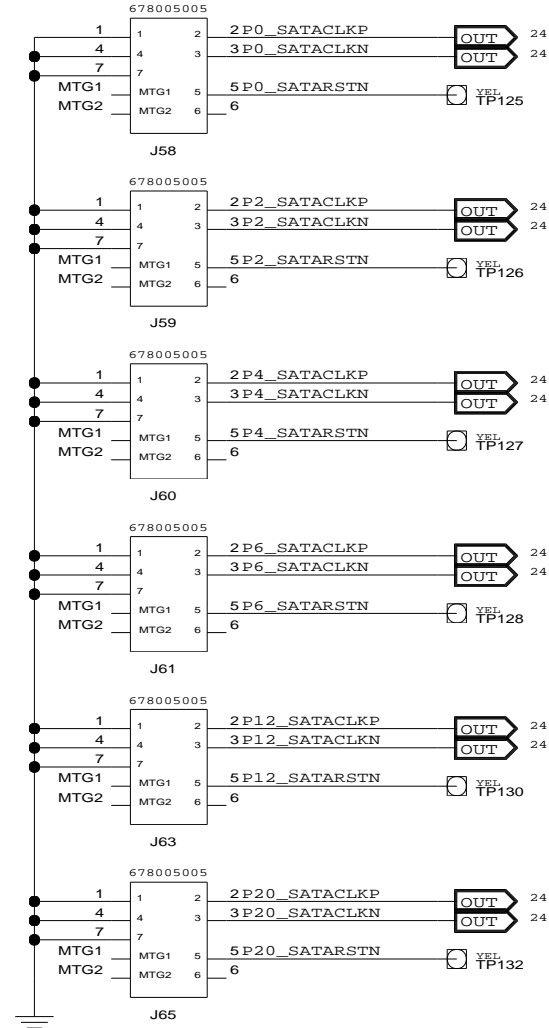
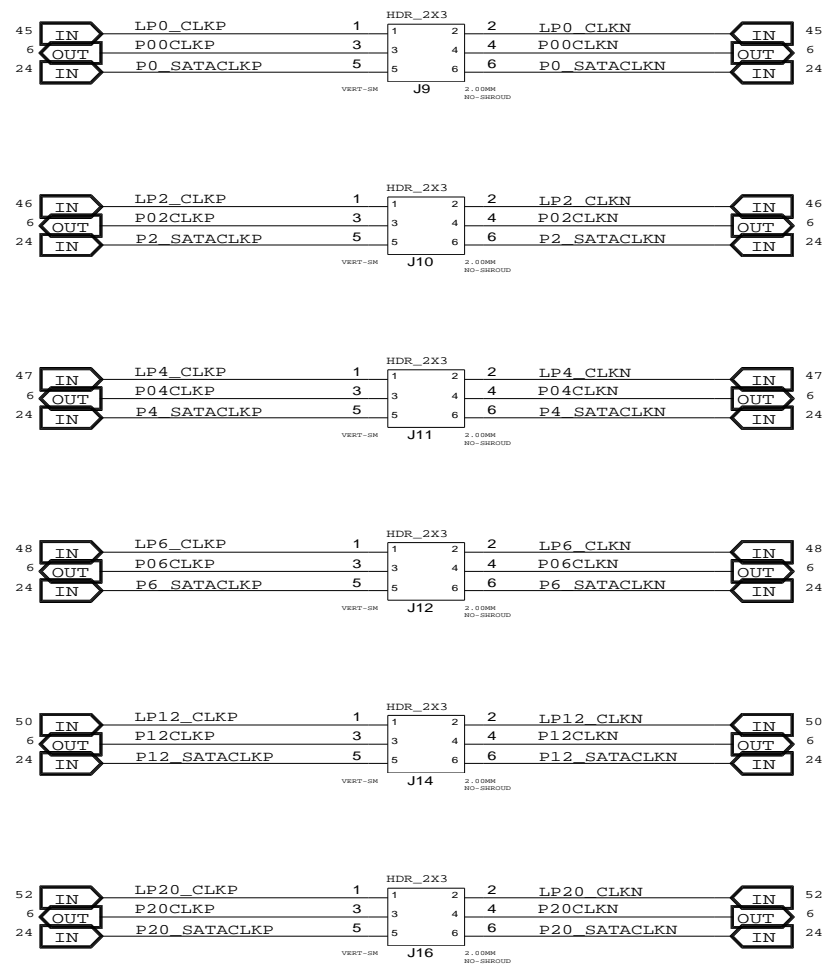

CONFIDENTIAL PROPERTY OF INTEGRATED DEVICE TECHNOLOGY, INC.
 6024 SILVER CREEK VALLEY ROAD. SAN JOSE, CA 95138
 COPYRIGHT (C) 2010 IDT

TITLE EB-LOGAN-23			
CLOCK SELECTOR DUT PCLK 0-20, GCLK 0-1			
SIZE B	DRAWING NO. SCH-PESEB-001	FAB P/N 18-691-001	REV. 2.0
AUTHOR Tony Tran		CHECKED BY Derek Huang	
Thu Jul 01 15:00:59 2010			SHEET 24 OF 52

SXXCLK - SLOT CLK
 BSXXCLK - BUFFER SLOT CLK
 LSXXCLK - LOCAL CLOCK GEN. SLOT CLK
 SHXXCLK - SLOT HDR.CLK

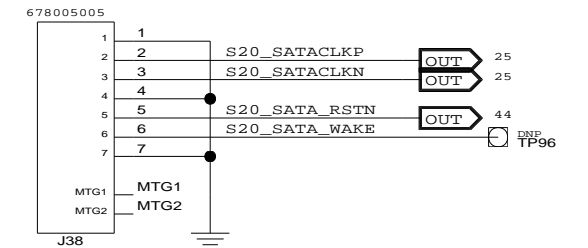
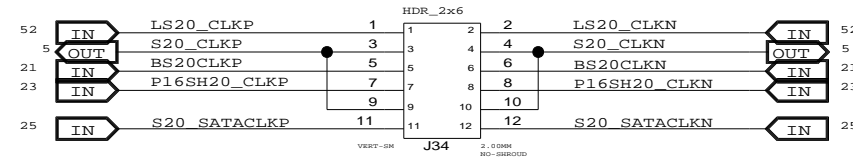
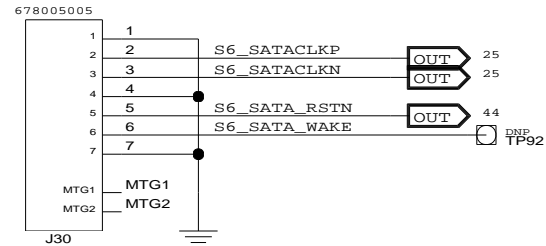
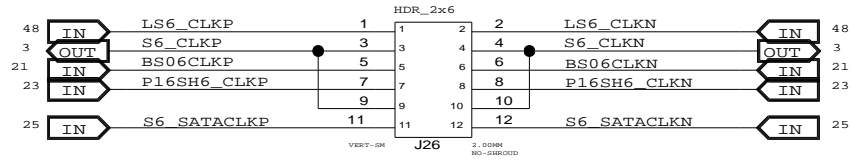
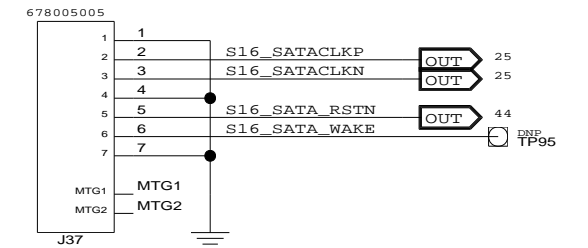
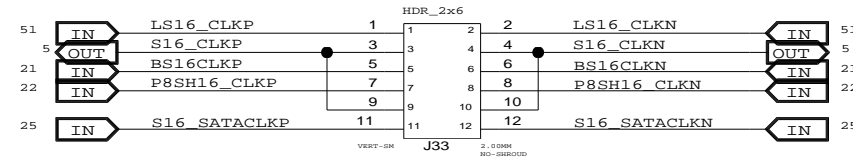
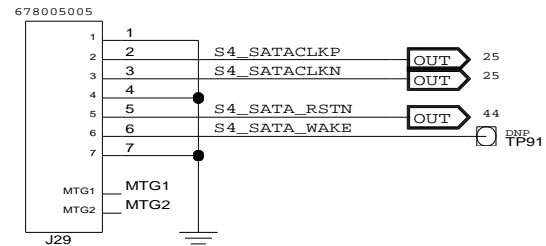
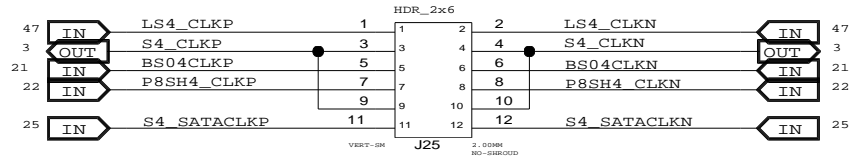
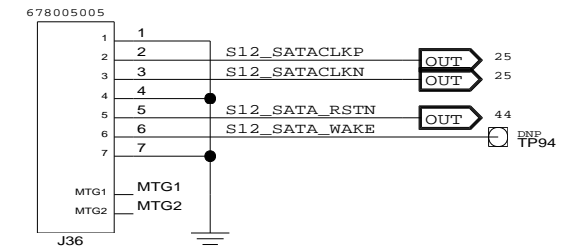
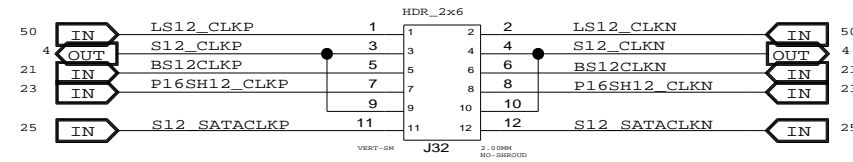
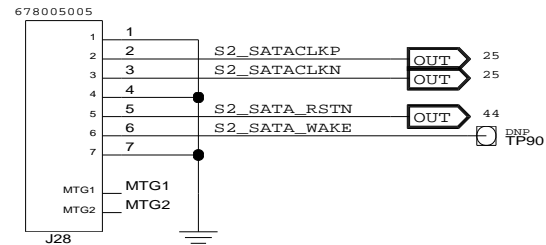
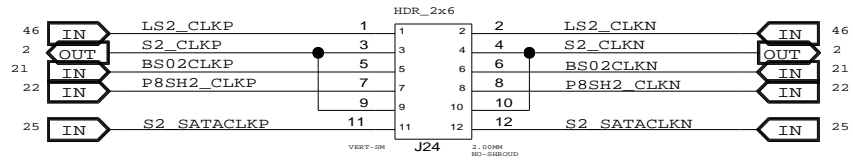
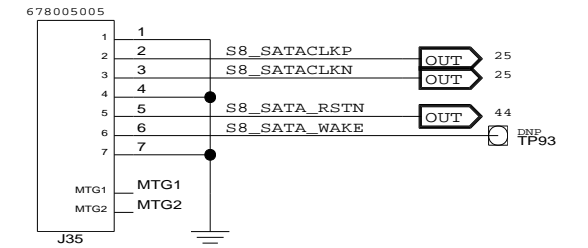
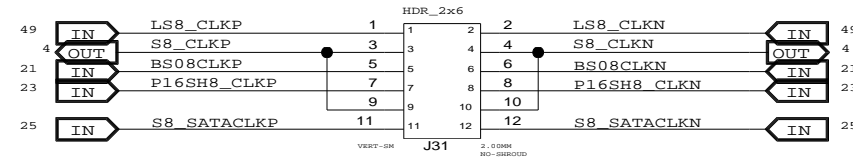
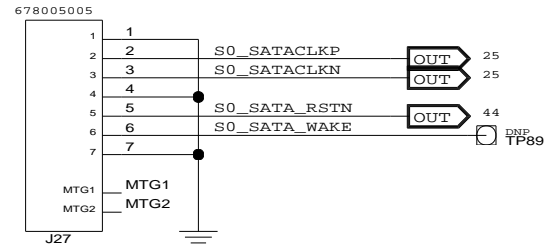
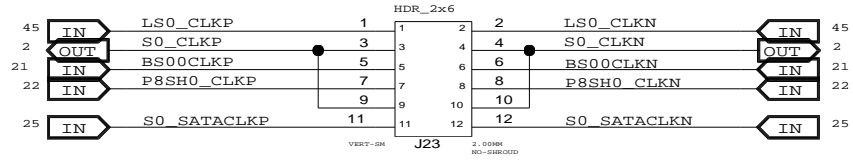

		TITLE EB-LOGAN-23		
		CLOCK SELECTOR SLOTS 0-20		
SIZE	DRAWING NO.	FAB P/N	REV.	
B	SCH-PESEB-001	18-691-001	2.0	
AUTHOR		CHECKED BY		
Tony Tran		Derek Huang		
Thu Jul 01 15:00:59 2010			SHEET 25 OF 52	

CONFIDENTIAL PROPERTY OF INTEGRATED DEVICE TECHNOLOGY, INC.
 6024 SILVER CREEK VALLEY ROAD. SAN JOSE, CA 95138
 COPYRIGHT (C) 2010 IDT

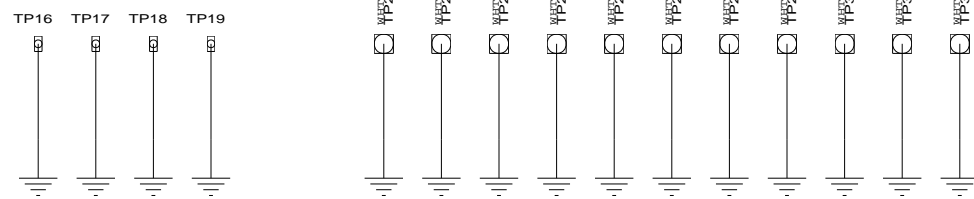
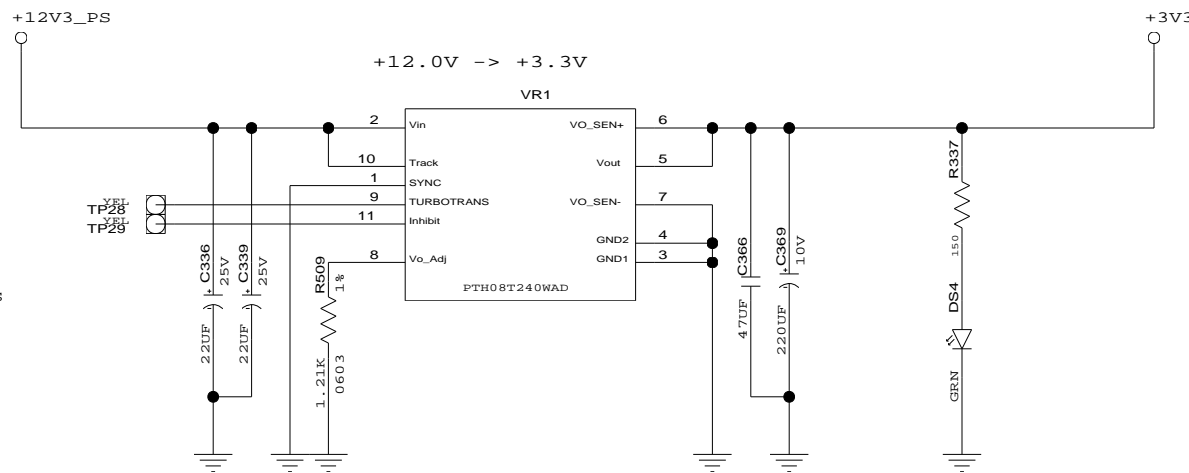
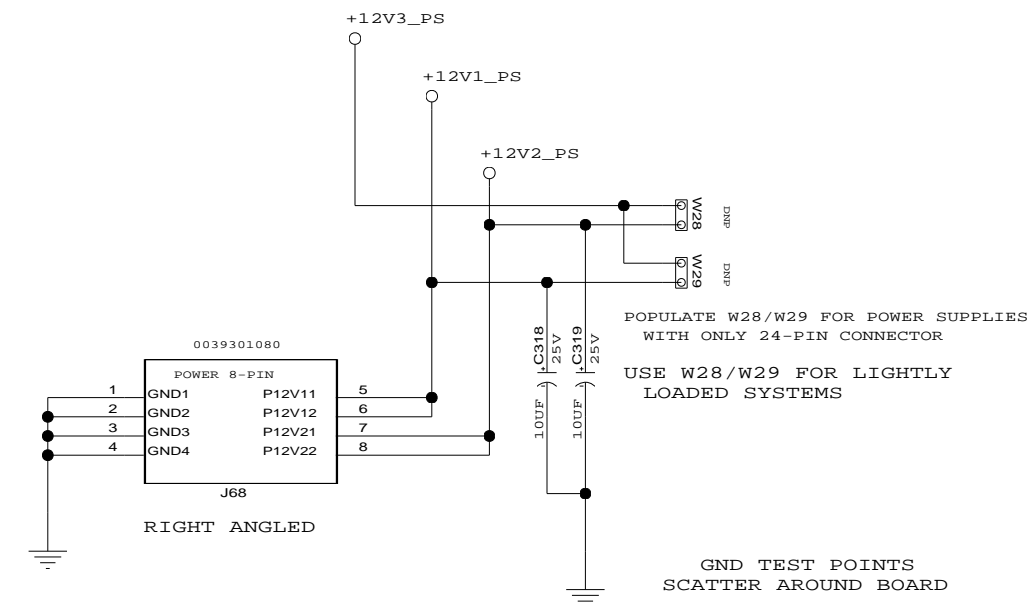
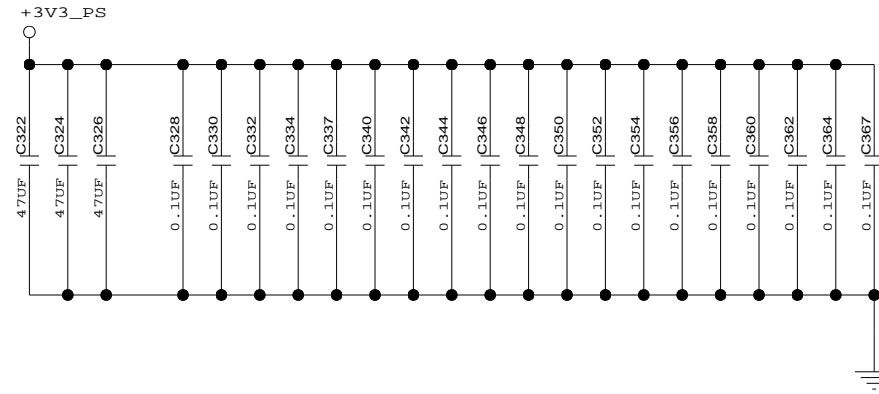
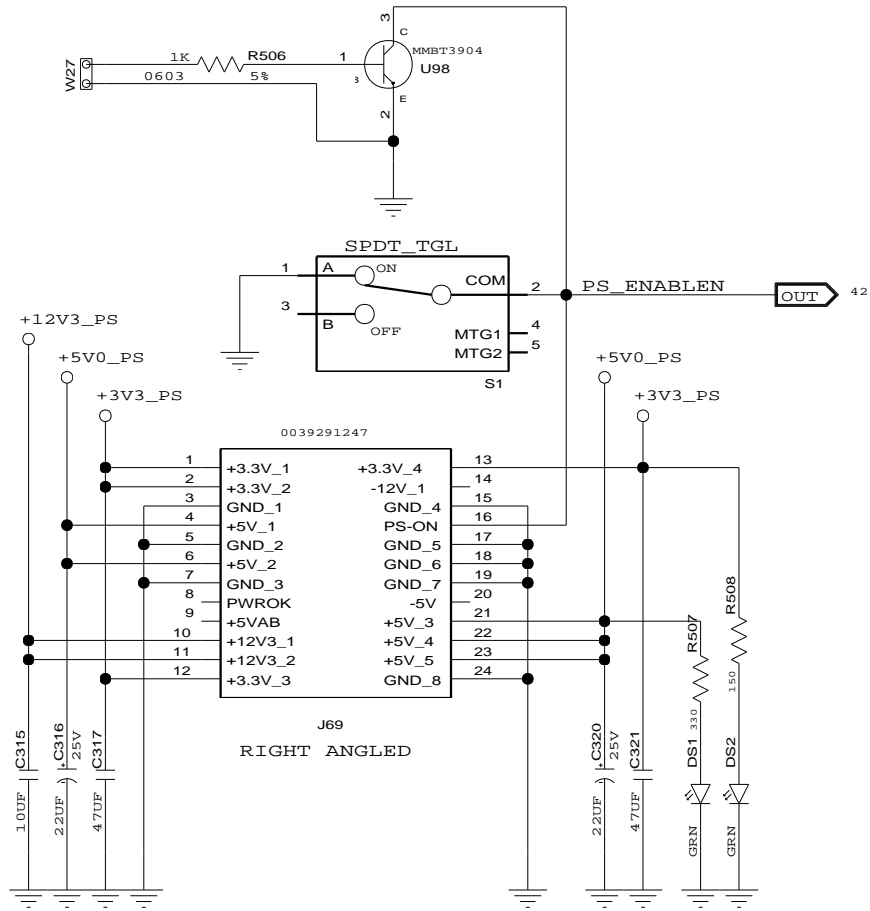

CONFIDENTIAL PROPERTY OF INTEGRATED DEVICE TECHNOLOGY, INC.
6024 SILVER CREEK VALLEY ROAD, SAN JOSE, CA 95138
COPYRIGHT (C) 2010 IDT

TITLE EB-LOGAN-23			
POWER CONNECTORS			
SIZE	DRAWING NO.	FAB P/N	REV.
B	SCH-PESEB-001	18-691-001	2.0
AUTHOR		CHECKED BY	
Tony Tran		Derek Huang	
Thu Jul 01 15:01:00 2010			SHEET 26 OF 52

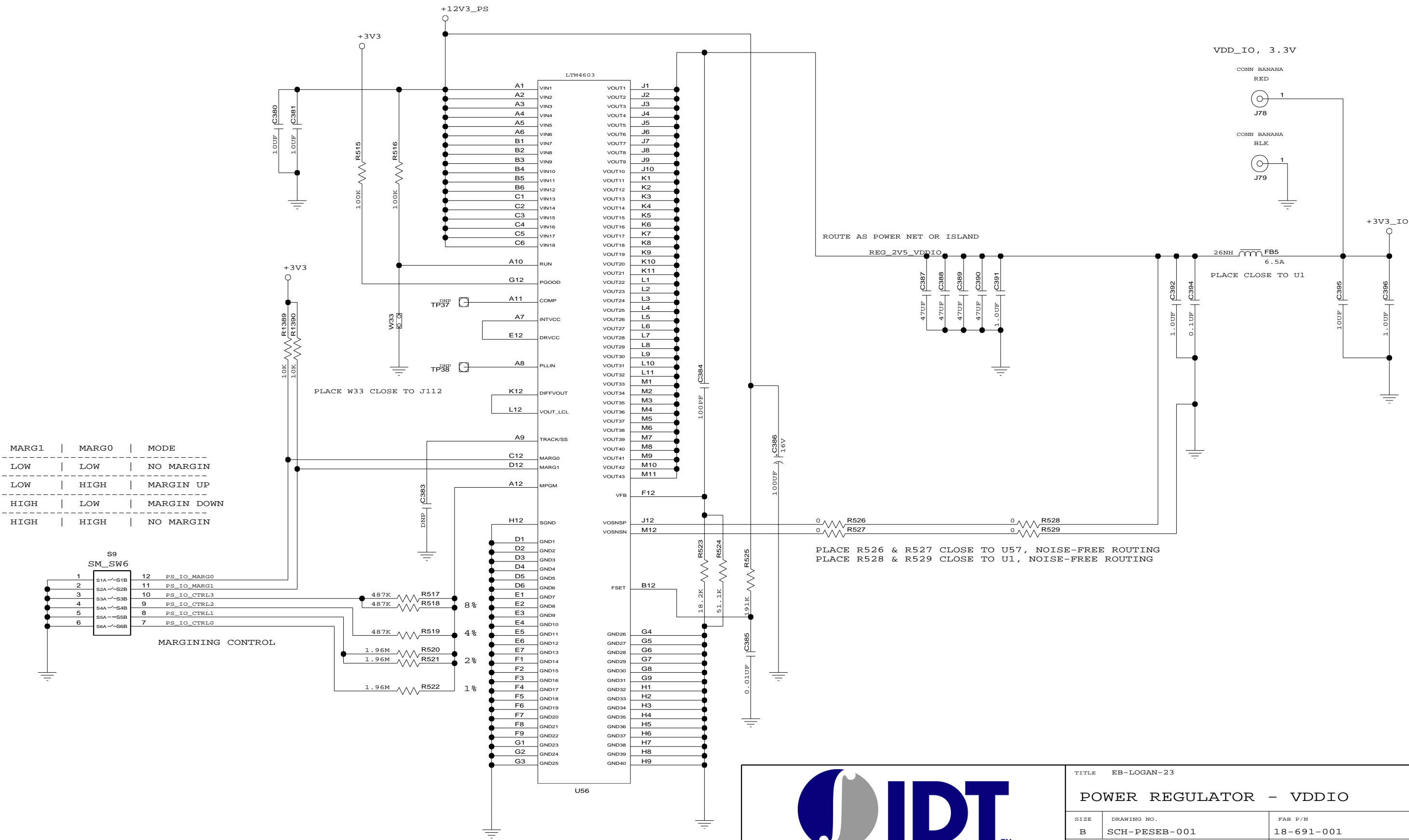

CONFIDENTIAL PROPERTY OF INTEGRATED DEVICE TECHNOLOGY, INC.
6024 SILVER CREEK VALLEY ROAD, SAN JOSE, CA 95138
COPYRIGHT (C) 2010 IDT

TITLE EB-LOGAN-23			
POWER REGULATOR - VDDIO			
SIZE	DRAWING NO.	FAB P/N	REV.
B	SCH-PESEB-001	18-691-001	2.0
AUTHOR		CHECKED BY	
Tony Tran		Derek Huang	
Thu Jul 01 15:01:00 2010			SHEET 27 OF 52

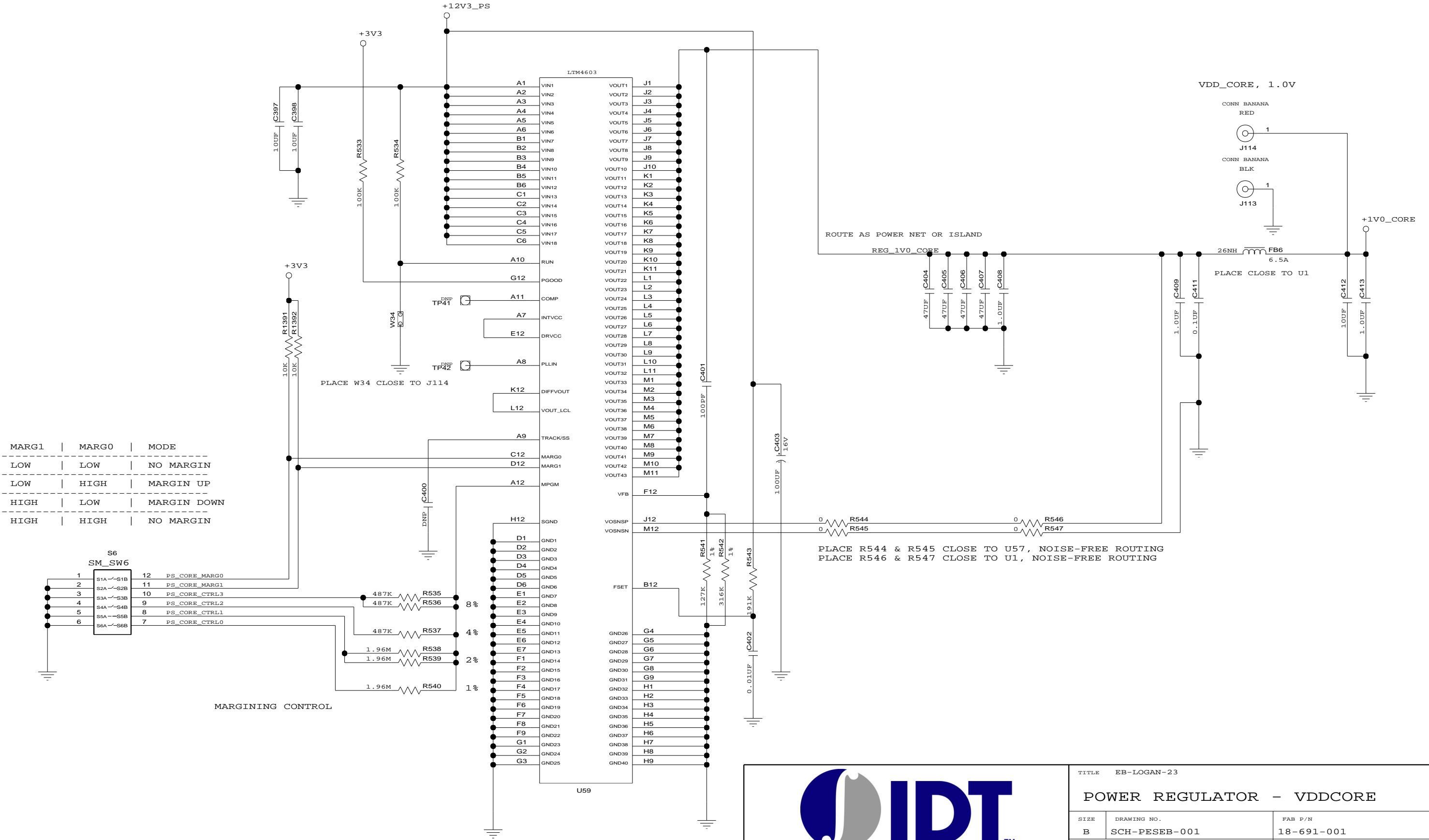

MARG1	MARG0	MODE
LOW	LOW	NO MARGIN
LOW	HIGH	MARGIN UP
HIGH	LOW	MARGIN DOWN
HIGH	HIGH	NO MARGIN

MARGINING CONTROL



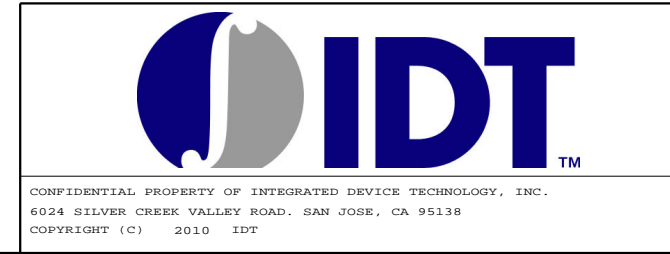
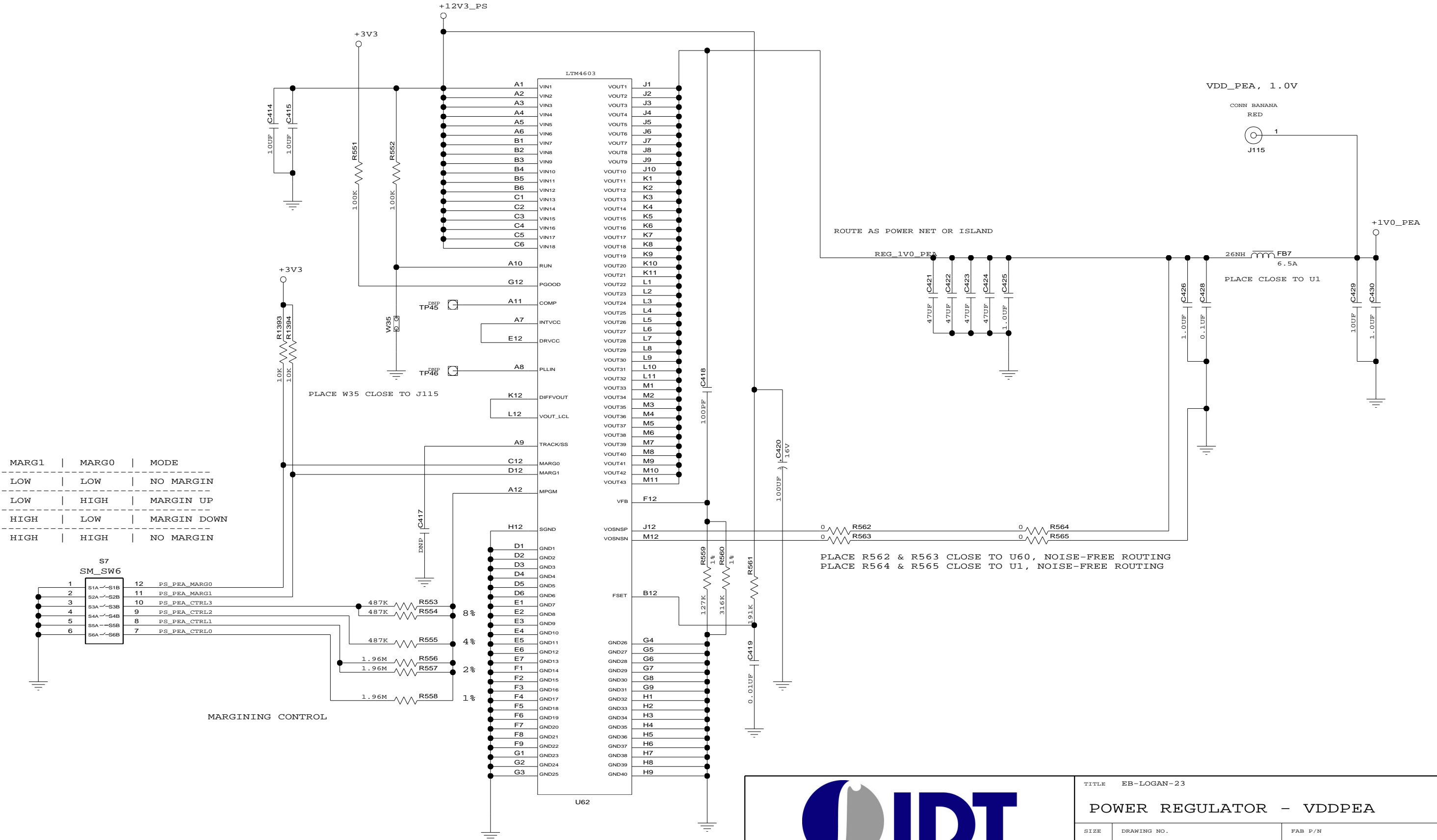

CONFIDENTIAL PROPERTY OF INTEGRATED DEVICE TECHNOLOGY, INC.
6024 SILVER CREEK VALLEY ROAD, SAN JOSE, CA 95138
COPYRIGHT (C) 2010 IDT

TITLE EB-LOGAN-23			
POWER REGULATOR - VDDCORE			
SIZE	DRAWING NO.	FAB P/N	REV.
B	SCH-PESEB-001	18-691-001	2.0
AUTHOR		CHECKED BY	
Tony Tran		Derek Huang	
Thu Jul 01 15:01:00 2010			SHEET 28 OF 52

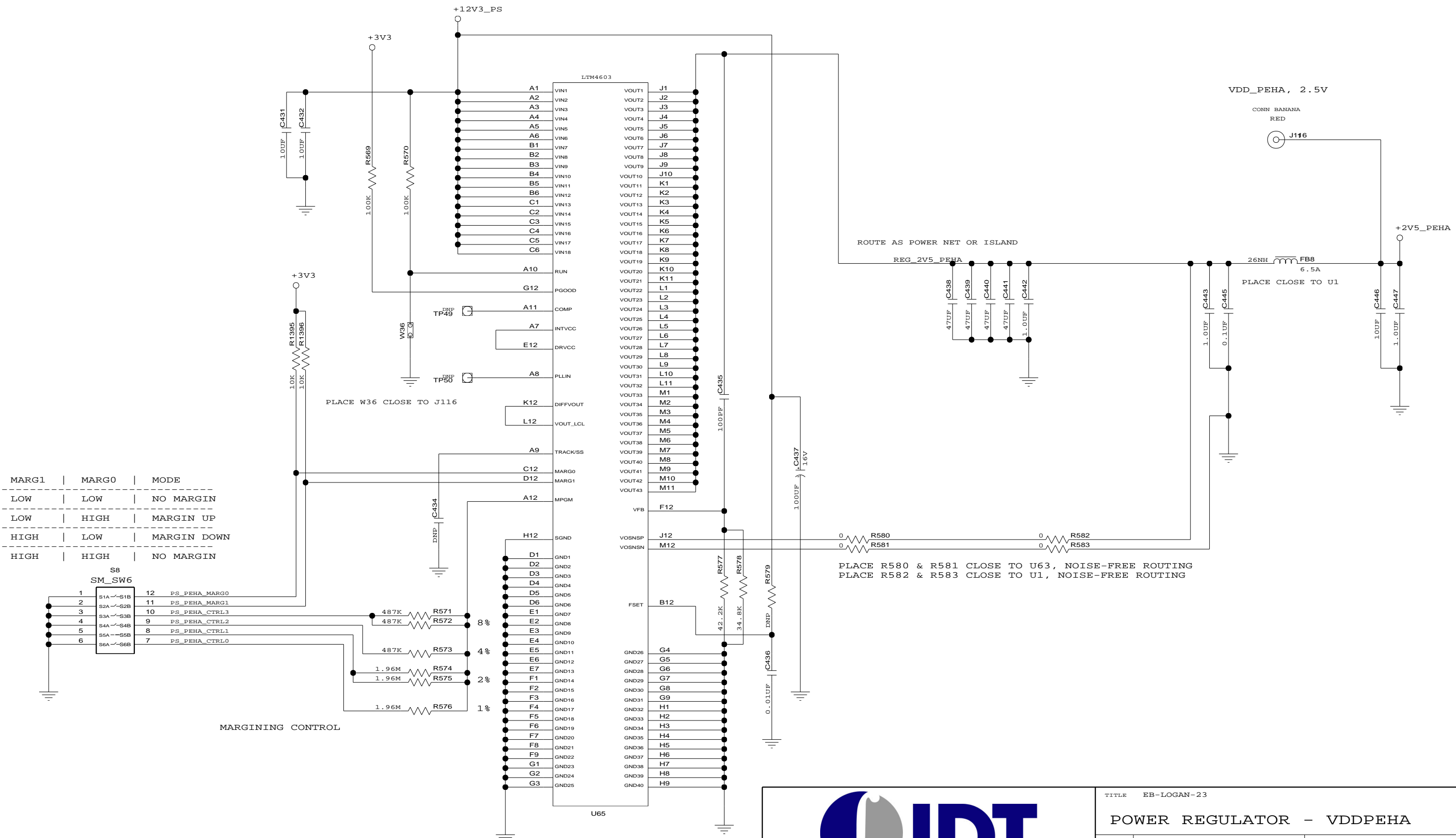

TITLE EB-LOGAN-23			
POWER REGULATOR - VDDPEA			
SIZE B	DRAWING NO. SCH-PESEB-001	FAB P/N 18-691-001	REV. 2.0
AUTHOR Tony Tran		CHECKED BY Derek Huang	
Thu Jul 01 15:01:00 2010			SHEET 29 OF 52

CONFIDENTIAL PROPERTY OF INTEGRATED DEVICE TECHNOLOGY, INC.
6024 SILVER CREEK VALLEY ROAD, SAN JOSE, CA 95138
COPYRIGHT (C) 2010 IDT

TITLE EB-LOGAN-23			
POWER REGULATOR - VDDPEHA			
SIZE	DRAWING NO.	FAB P/N	REV.
B	SCH-PESEB-001	18-691-001	2.0
AUTHOR		CHECKED BY	
Tony Tran		Derek Huang	
Thu Jul 01 15:01:01 2010			SHEET 30 OF 52

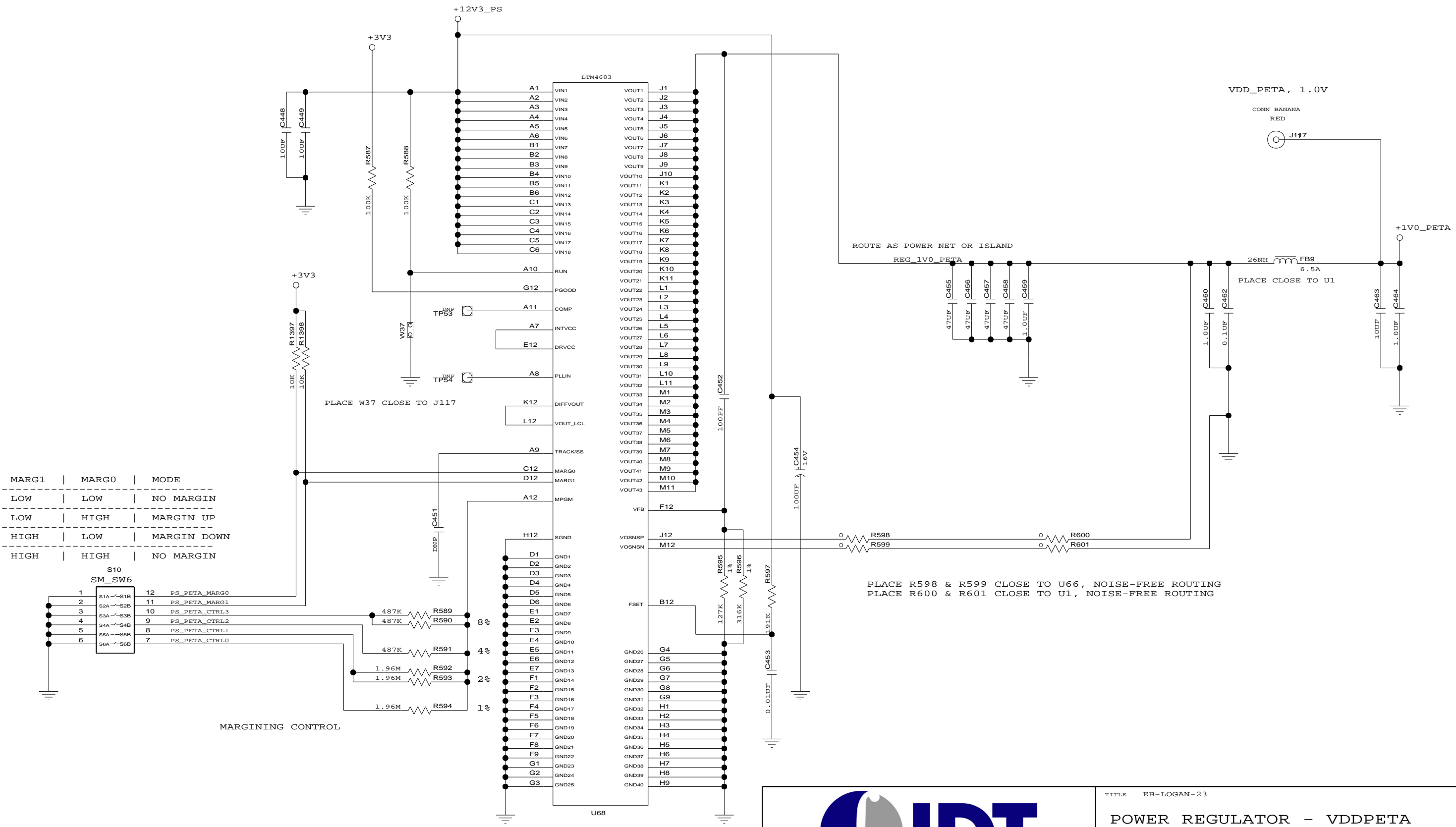

MARG1	MARG0	MODE
LOW	LOW	NO MARGIN
LOW	HIGH	MARGIN UP
HIGH	LOW	MARGIN DOWN
HIGH	HIGH	NO MARGIN

S10
SM_SW6

MARGINING CONTROL

PLACE R598 & R599 CLOSE TO U66, NOISE-FREE ROUTING
PLACE R600 & R601 CLOSE TO U1, NOISE-FREE ROUTING



CONFIDENTIAL PROPERTY OF INTEGRATED DEVICE TECHNOLOGY, INC.
6024 SILVER CREEK VALLEY ROAD, SAN JOSE, CA 95138
COPYRIGHT (C) 2010 IDT

TITLE EB-LOGAN-23			
POWER REGULATOR - VDDPETA			
SIZE B	DRAWING NO. SCH-PESEB-001	FAB P/N 18-691-001	REV. 2.0
AUTHOR Tony Tran		CHECKED BY Derek Huang	
Thu Jul 01 15:01:01 2010			SHEET 31 OF 52

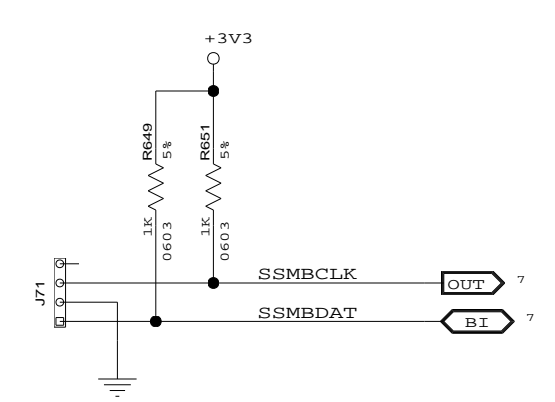
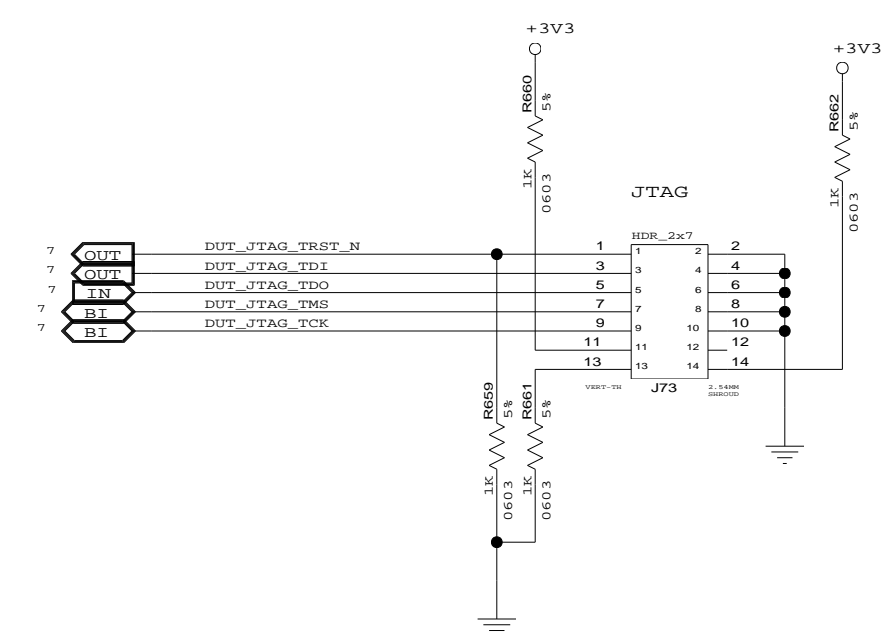
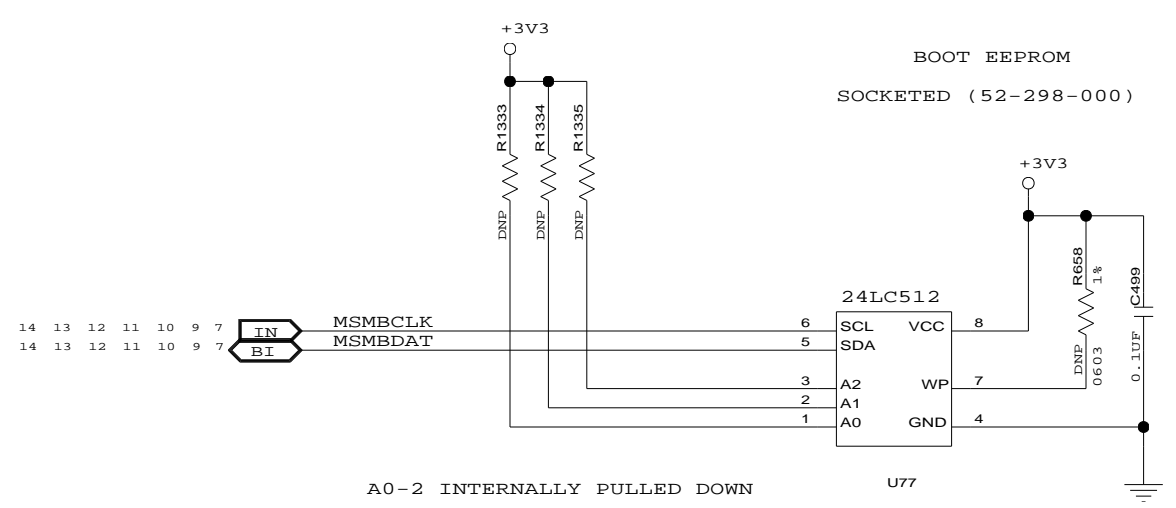
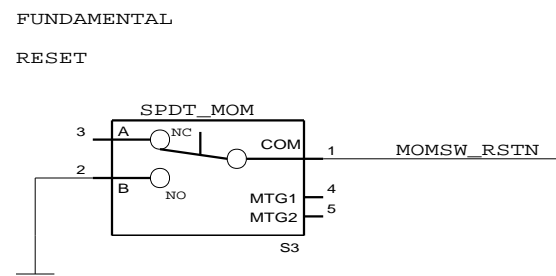
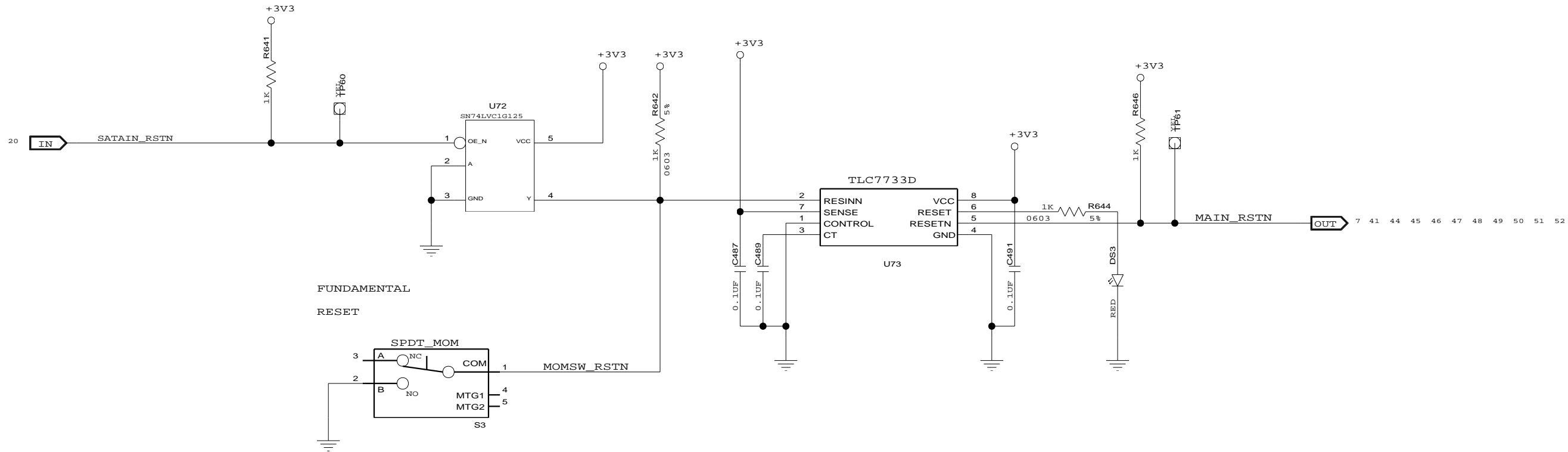

		TITLE EB-LOGAN-23 RESET, SMBUS, EEPROM, JTAG		
		SIZE B DRAWING NO. SCH-PESEB-001 AUTHOR Tony Tran	FAB P/N 18-691-001 CHECKED BY Derek Huang	REV. 2.0
CONFIDENTIAL PROPERTY OF INTEGRATED DEVICE TECHNOLOGY, INC. 6024 SILVER CREEK VALLEY ROAD. SAN JOSE, CA 95138 COPYRIGHT (C) 2010 IDT		Thu Jul 01 15:01:01 2010		SHEET 32 OF 52

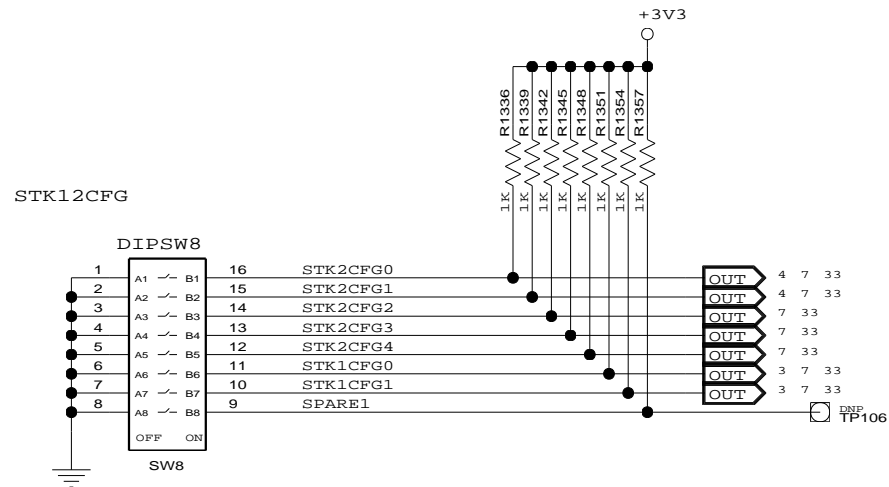

(GREEN) ACTIVE HIGH - DIP STK12CFG

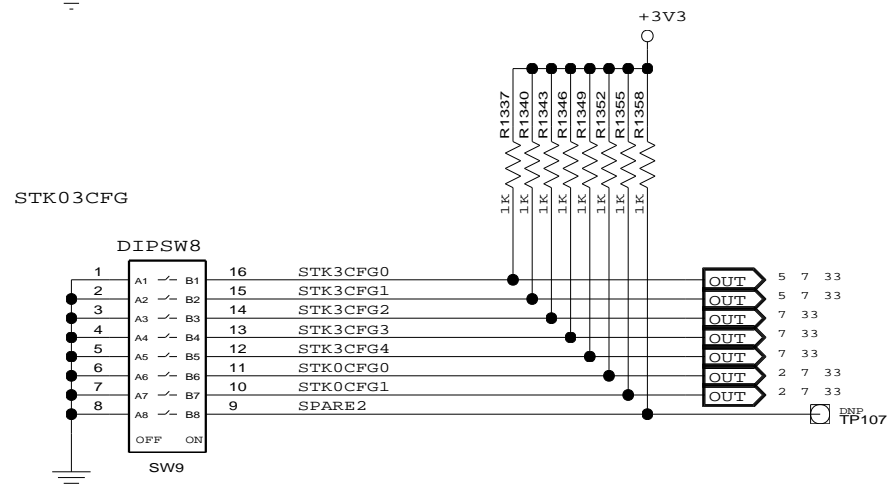
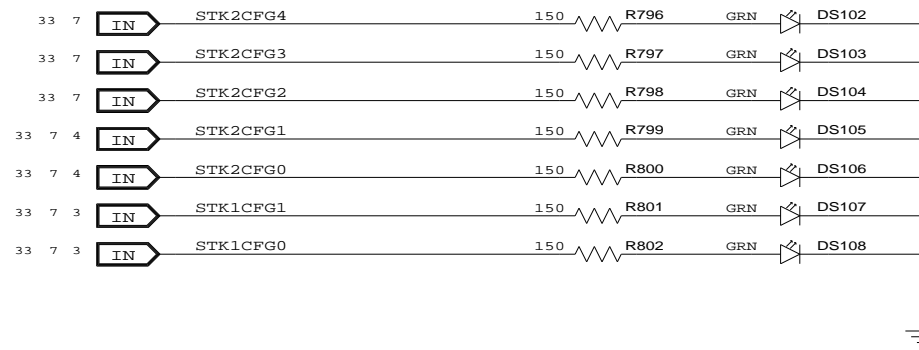

(GREEN) ACTIVE HIGH - DIP STK03CFG

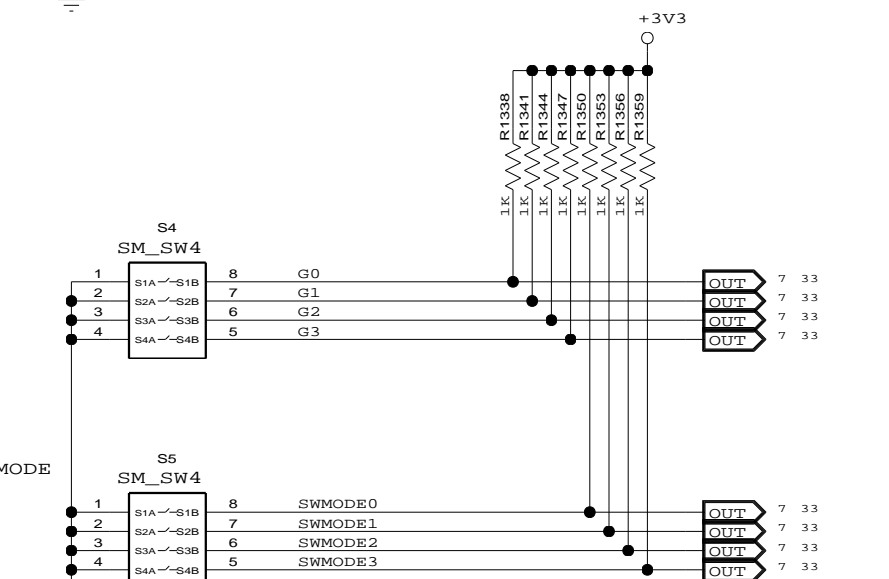
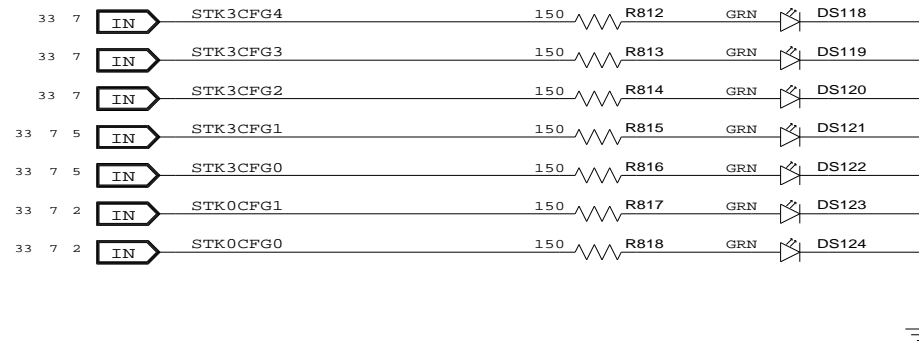

(GREEN) ACTIVE HIGH - DIP MODE

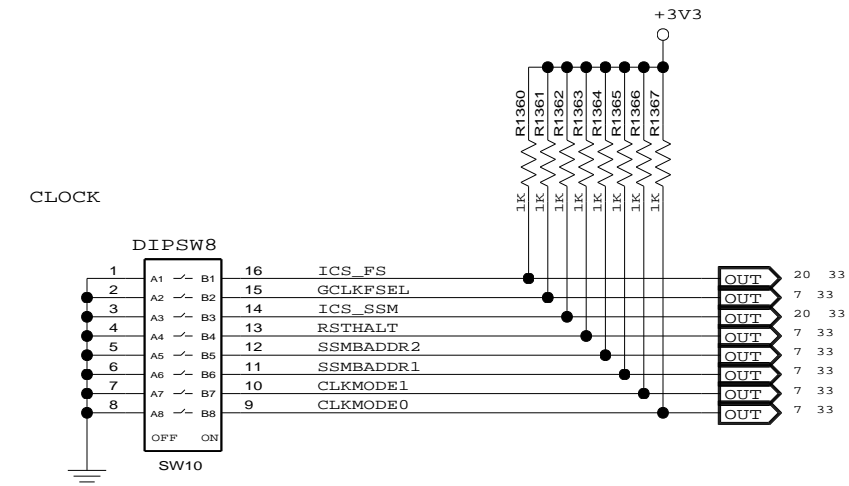
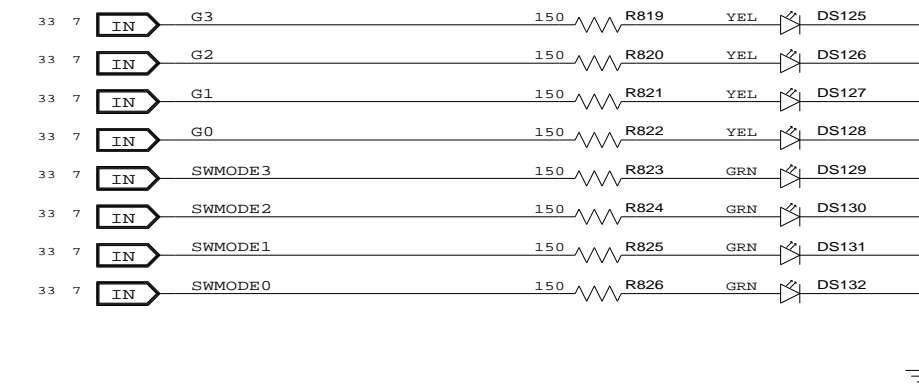

(GREEN) ACTIVE HIGH - DIP CLOCK

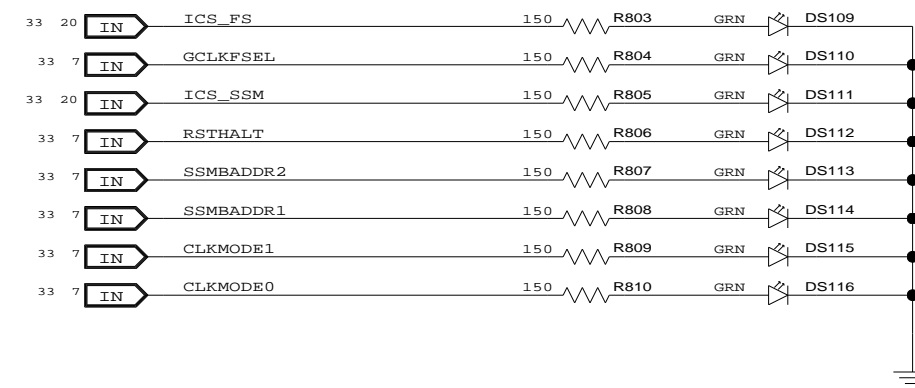

CONFIDENTIAL PROPERTY OF INTEGRATED DEVICE TECHNOLOGY, INC.
6024 SILVER CREEK VALLEY ROAD, SAN JOSE, CA 95138
COPYRIGHT (C) 2010 IDT

TITLE EB-LOGAN-23			
DIP SWITCHES			
SIZE	DRAWING NO.	FAB P/N	REV.
B	SCH-PESEB-001	18-691-001	2.0
AUTHOR		CHECKED BY	
Tony Tran		Derek Huang	
Thu Jul 01 15:01:01 2010			SHEET 33 OF 52

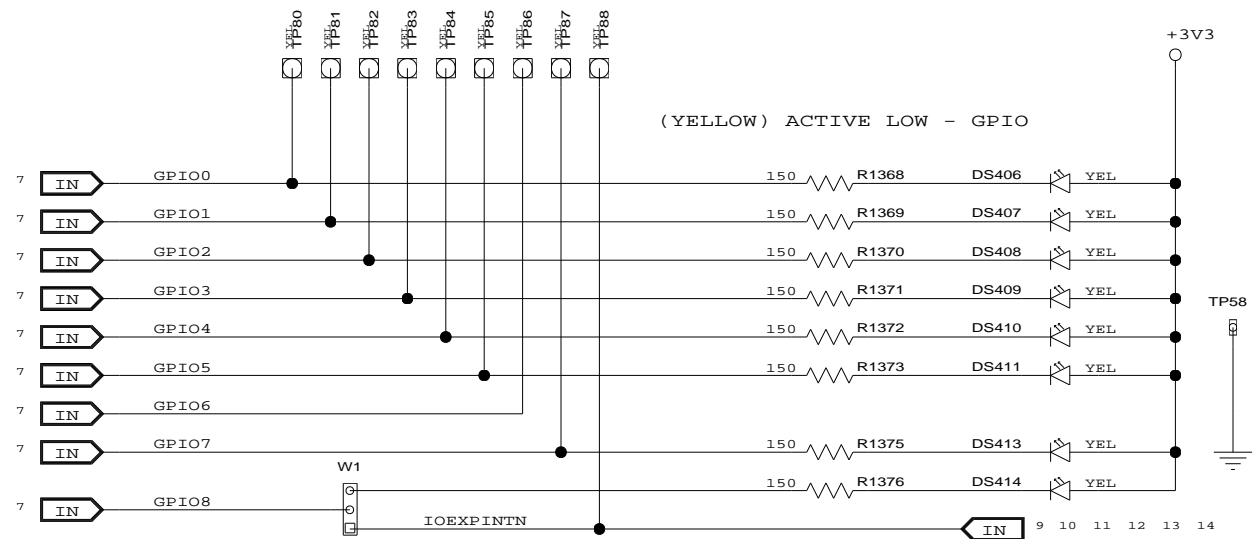

GPIO	ALT0	ALT1
0	PART0PERSTN	P16LINKUPN
1	PART1PERSTN	P16ACTIVEN
2	PART2PERSTN	P4LINKUPN
3	PART3PERSTN	P4ACTIVEN
4	FAILOVER0	P0LINKUPN
5	GPEN	P0ACTIVEN
6	FAILOVER1	FAILOVER3
7	FAILOVER2	P8LINKUPN
8	IOEXPINTN W1:1-2	P8ACTIVEN W1:2-3

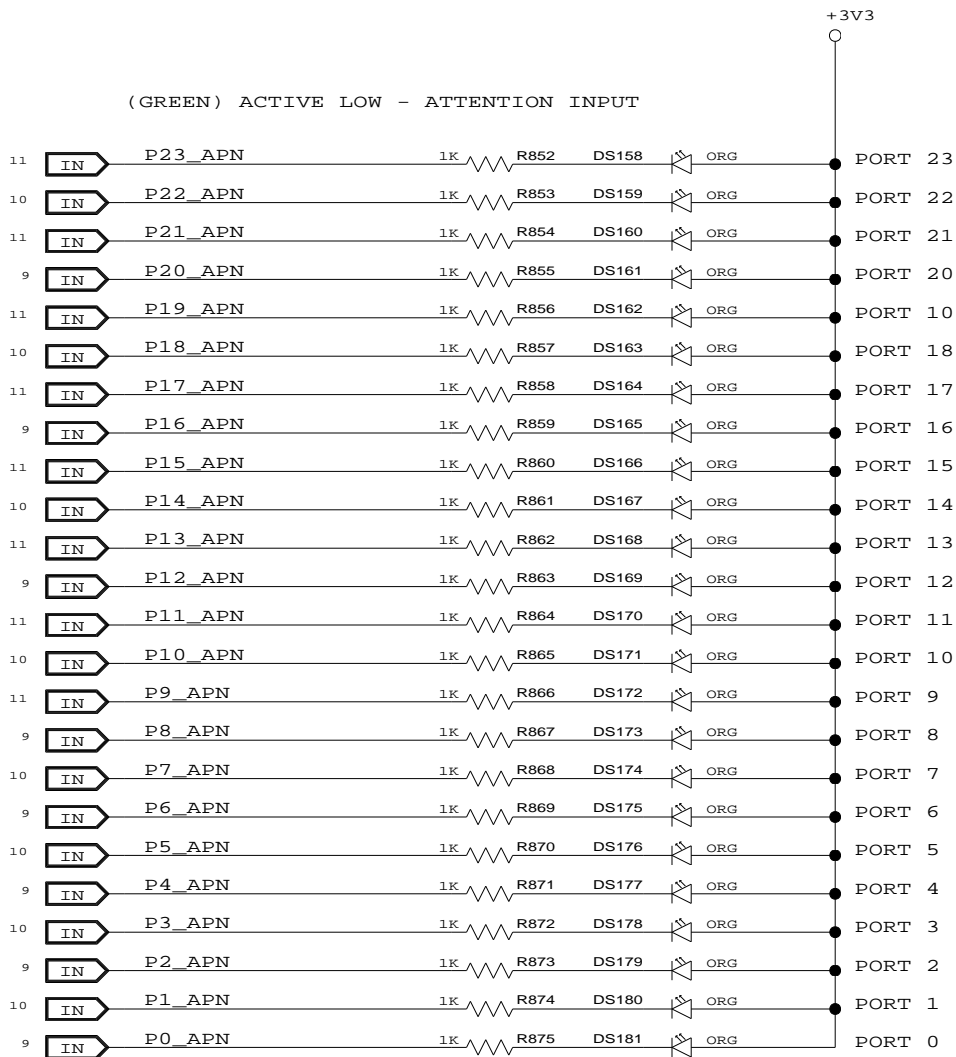

(YELLOW) ACTIVE LOW - PRESENCE DETECT

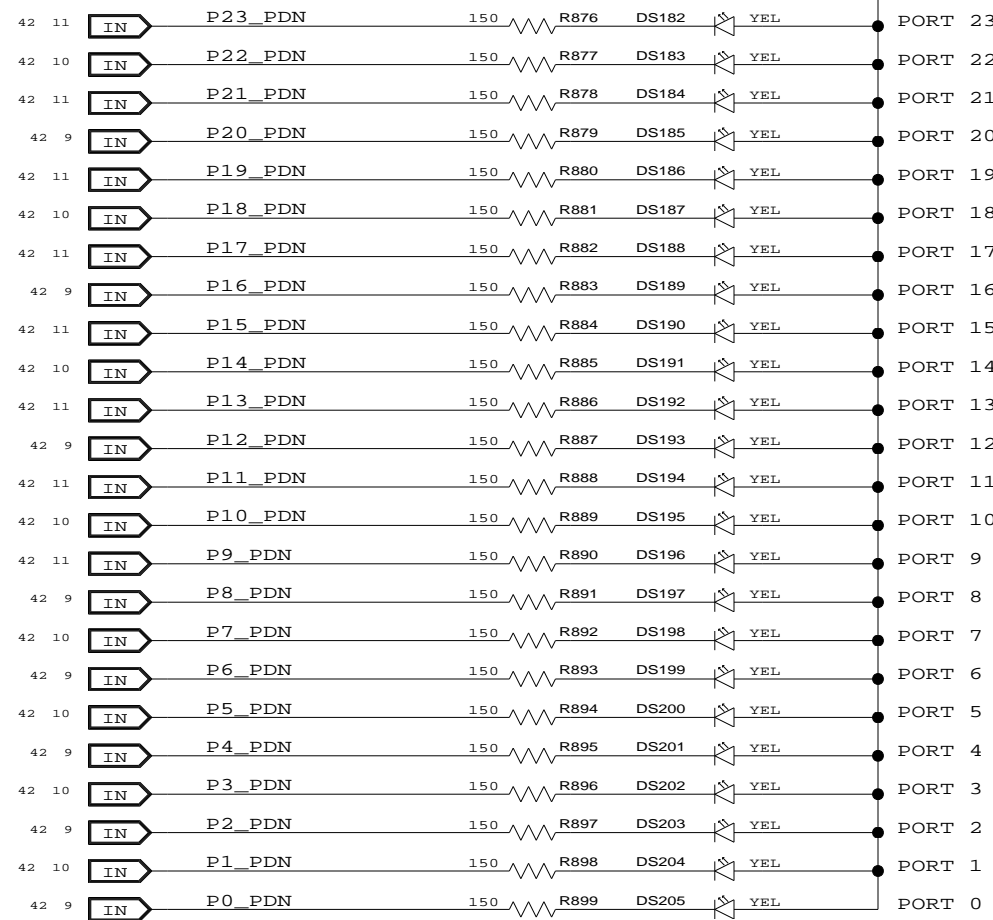

CONFIDENTIAL PROPERTY OF INTEGRATED DEVICE TECHNOLOGY, INC.
6024 SILVER CREEK VALLEY ROAD, SAN JOSE, CA 95138
COPYRIGHT (C) 2010 IDT

TITLE EB-LOGAN-23

LED - PORT STATUS (1 OF 7)

SIZE B	DRAWING NO. SCH-PESEB-001	FAB P/N 18-691-001	REV. 2.0
-----------	------------------------------	-----------------------	-------------

AUTHOR Tony Tran	CHECKED BY Derek Huang
---------------------	---------------------------

Thu Jul 01 15:01:02 2010

SHEET 34 OF 52

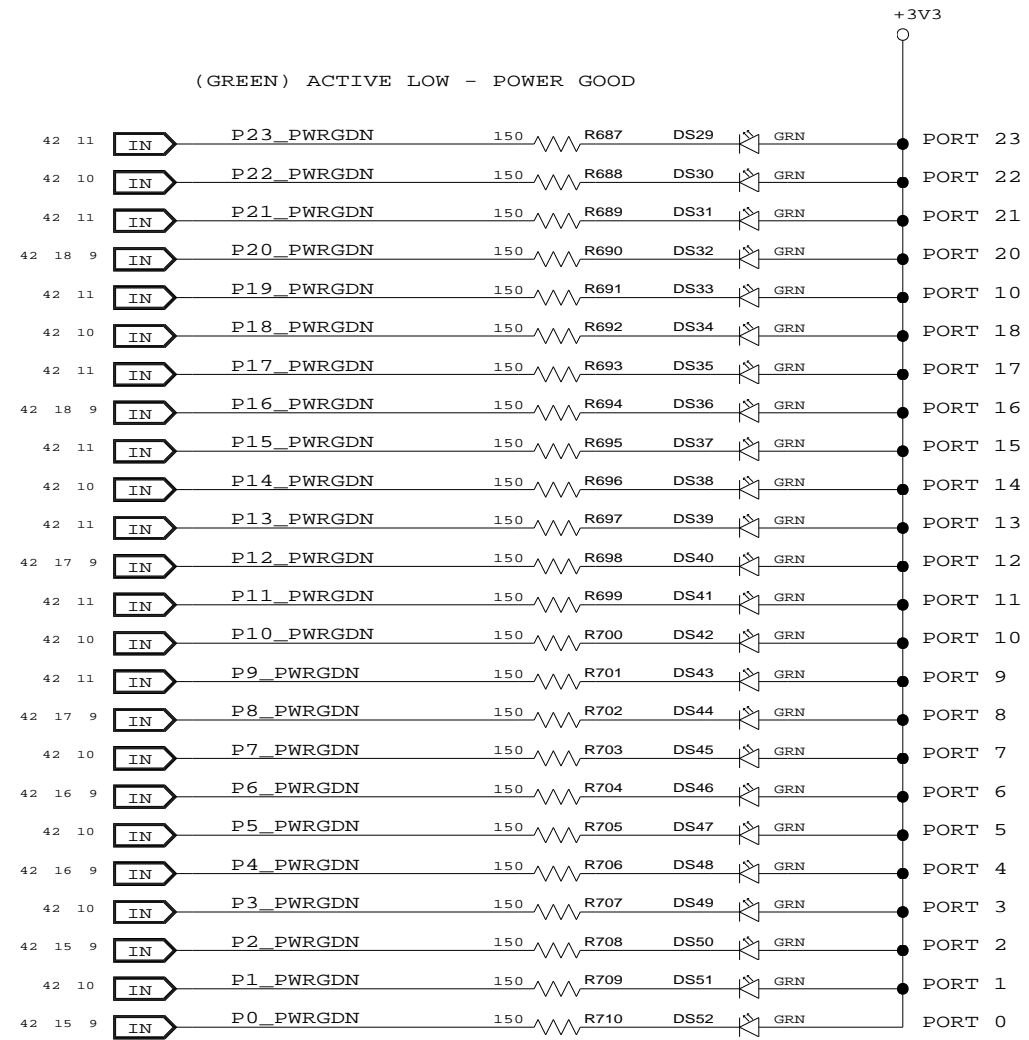
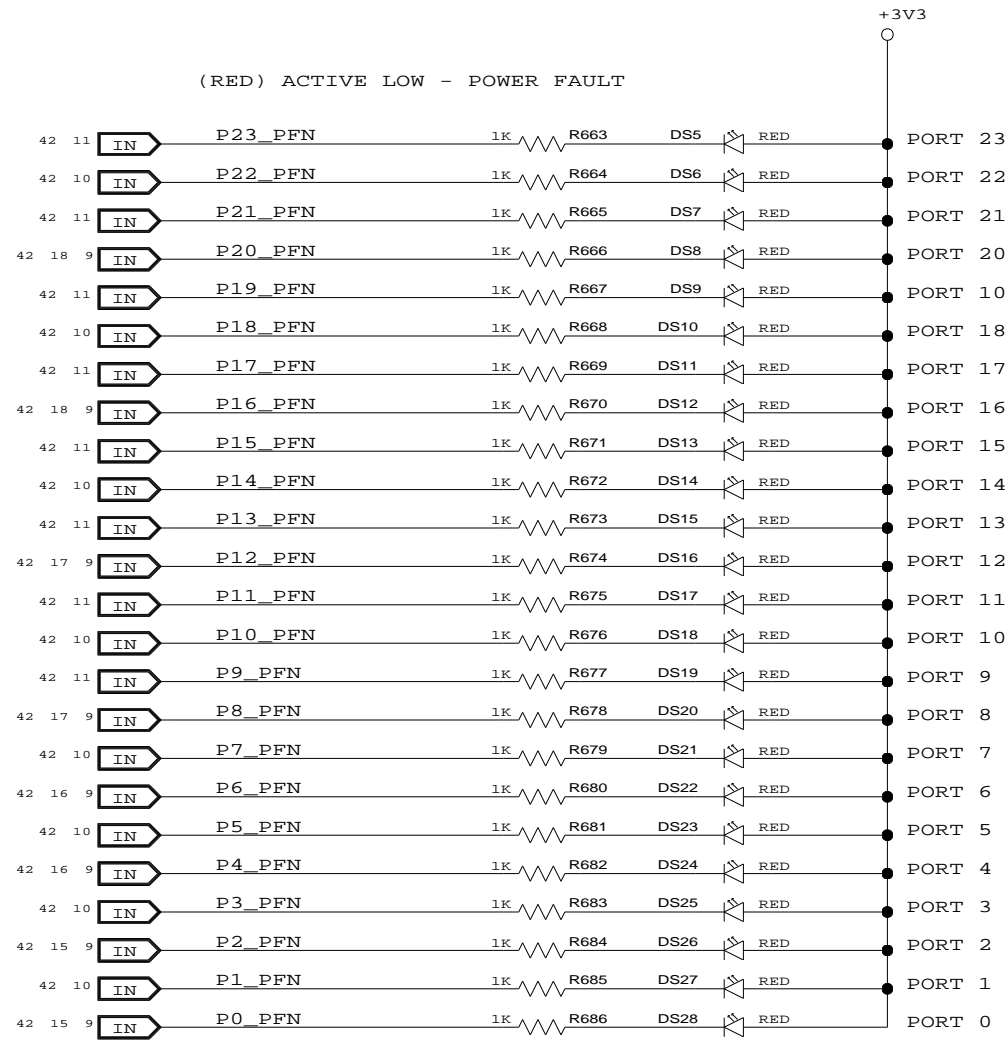

CONFIDENTIAL PROPERTY OF INTEGRATED DEVICE TECHNOLOGY, INC.
6024 SILVER CREEK VALLEY ROAD, SAN JOSE, CA 95138
COPYRIGHT (C) 2010 IDT

TITLE EB-LOGAN-23

LED - PORT STATUS (2 OF 7)

SIZE B	DRAWING NO. SCH-PESEB-001	FAB P/N 18-691-001	REV. 2.0
AUTHOR Tony Tran		CHECKED BY Derek Huang	
Thu Jul 01 15:01:02 2010			SHEET 35 OF 52

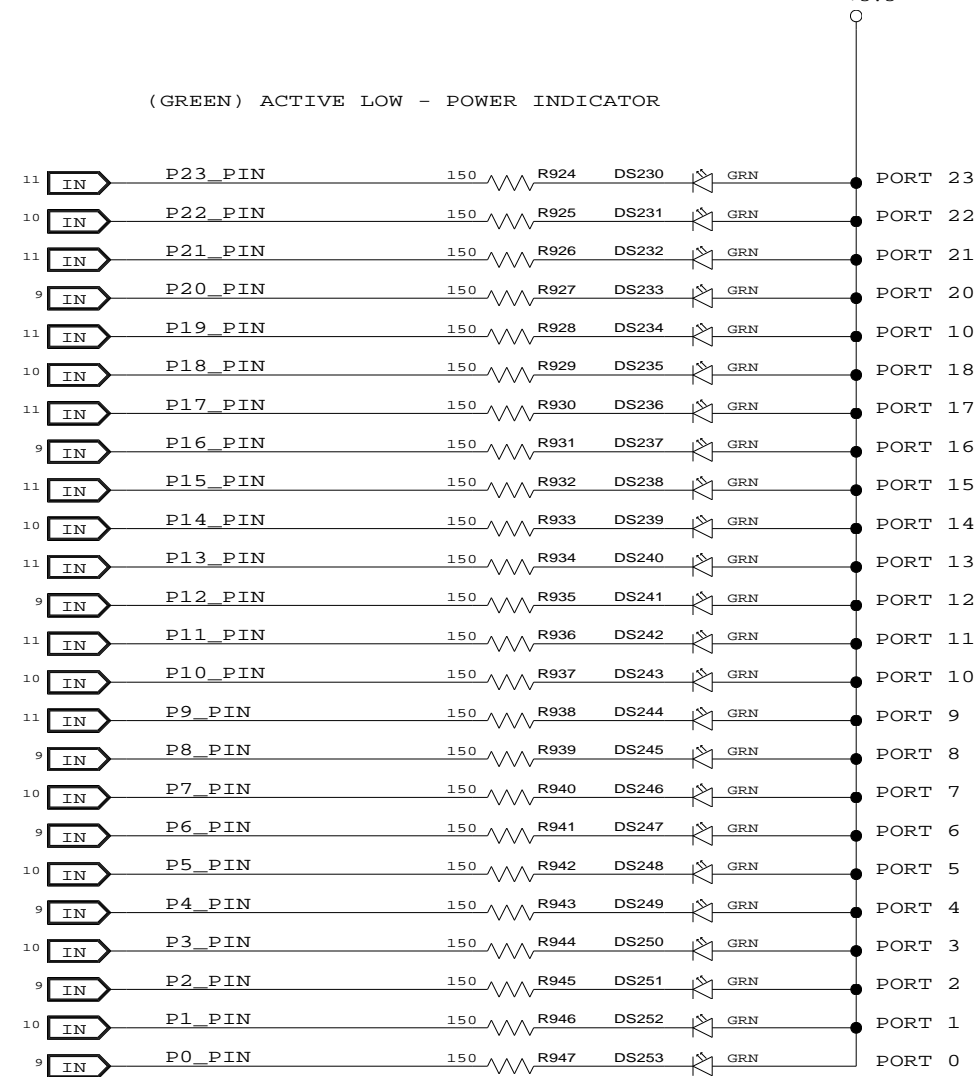
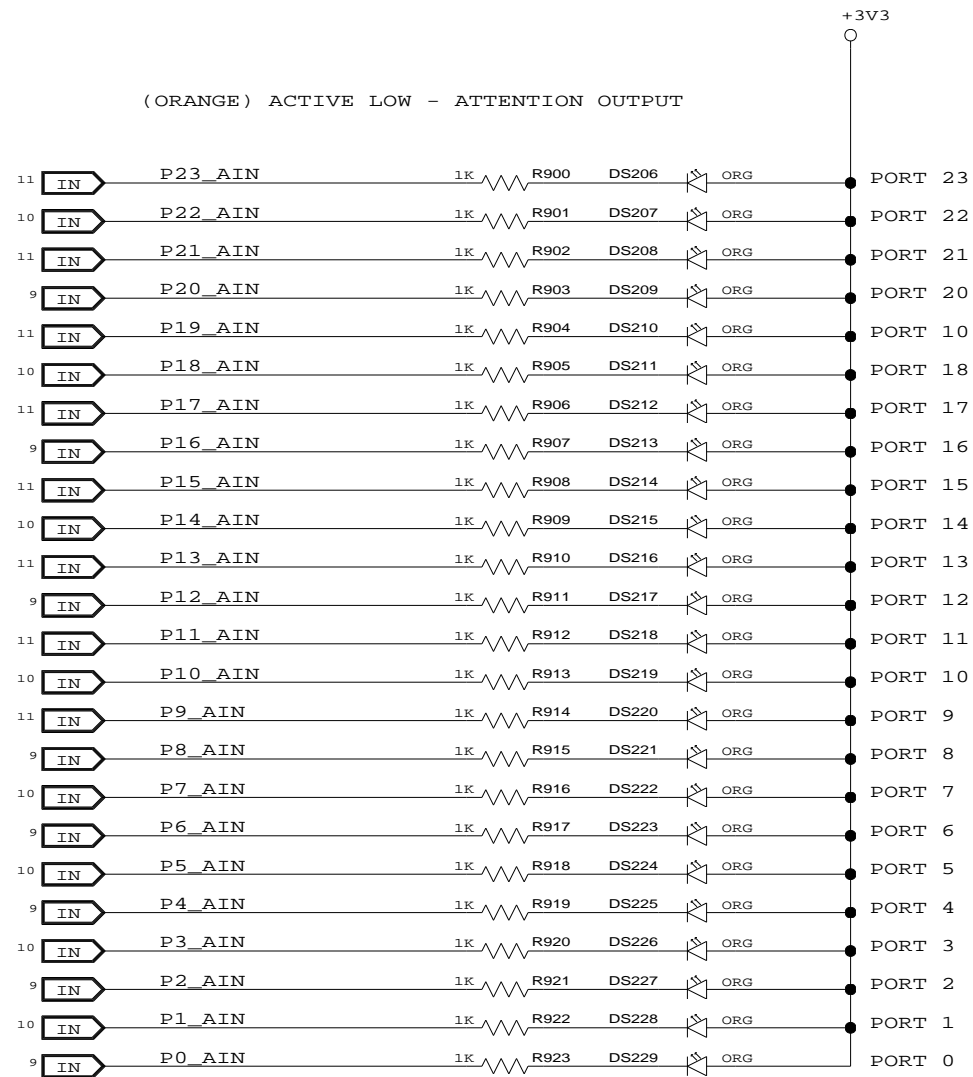

CONFIDENTIAL PROPERTY OF INTEGRATED DEVICE TECHNOLOGY, INC.
6024 SILVER CREEK VALLEY ROAD, SAN JOSE, CA 95138
COPYRIGHT (C) 2010 IDT

TITLE EB-LOGAN-23

LED - PORT STATUS (3 OF 7)

SIZE	DRAWING NO.	FAB P/N	REV.
B	SCH-PESEB-001	18-691-001	2.0
AUTHOR Tony Tran		CHECKED BY Derek Huang	
Thu Jul 01 15:01:02 2010			SHEET 36 OF 52

(GREEN) ACTIVE HIGH - POWER ENABLE

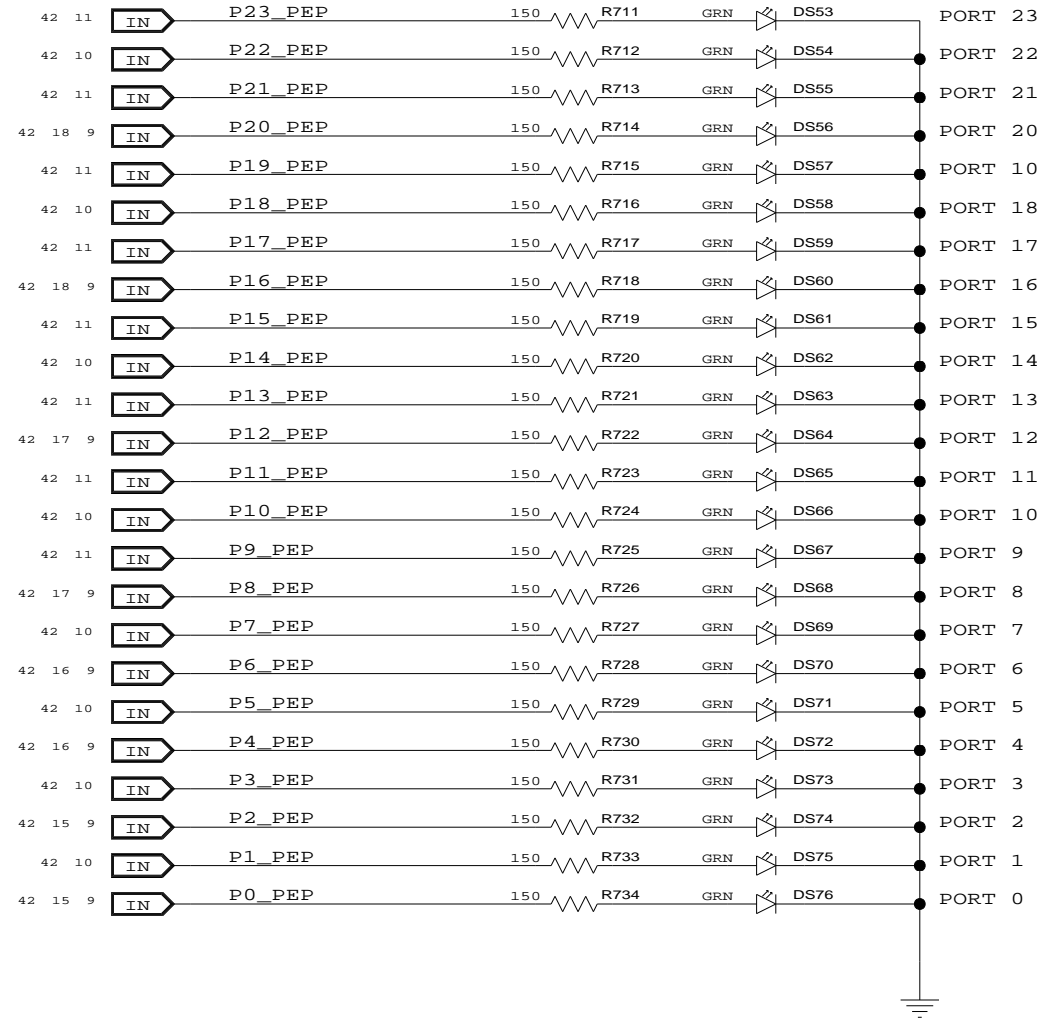

(RED) ACTIVE LOW - HP SLOT RST

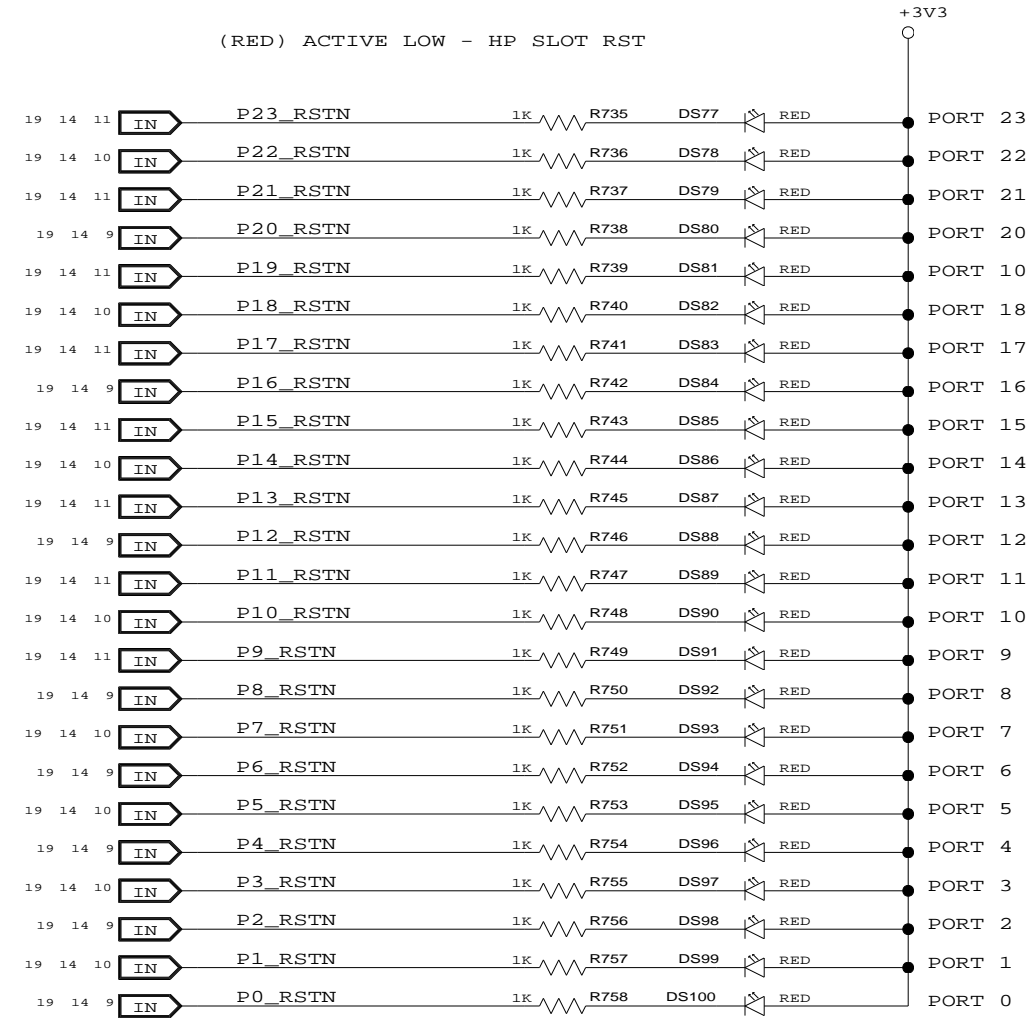

CONFIDENTIAL PROPERTY OF INTEGRATED DEVICE TECHNOLOGY, INC.
6024 SILVER CREEK VALLEY ROAD. SAN JOSE, CA 95138
COPYRIGHT (C) 2010 IDT

TITLE EB-LOGAN-23

LED - PORT STATUS (4 OF 7)

SIZE	DRAWING NO.	FAB P/N	REV.
B	SCH-PESEB-001	18-691-001	2.0

AUTHOR	CHECKED BY
Tony Tran	Derek Huang

Thu Jul 01 15:01:03 2010

SHEET 37 OF 52

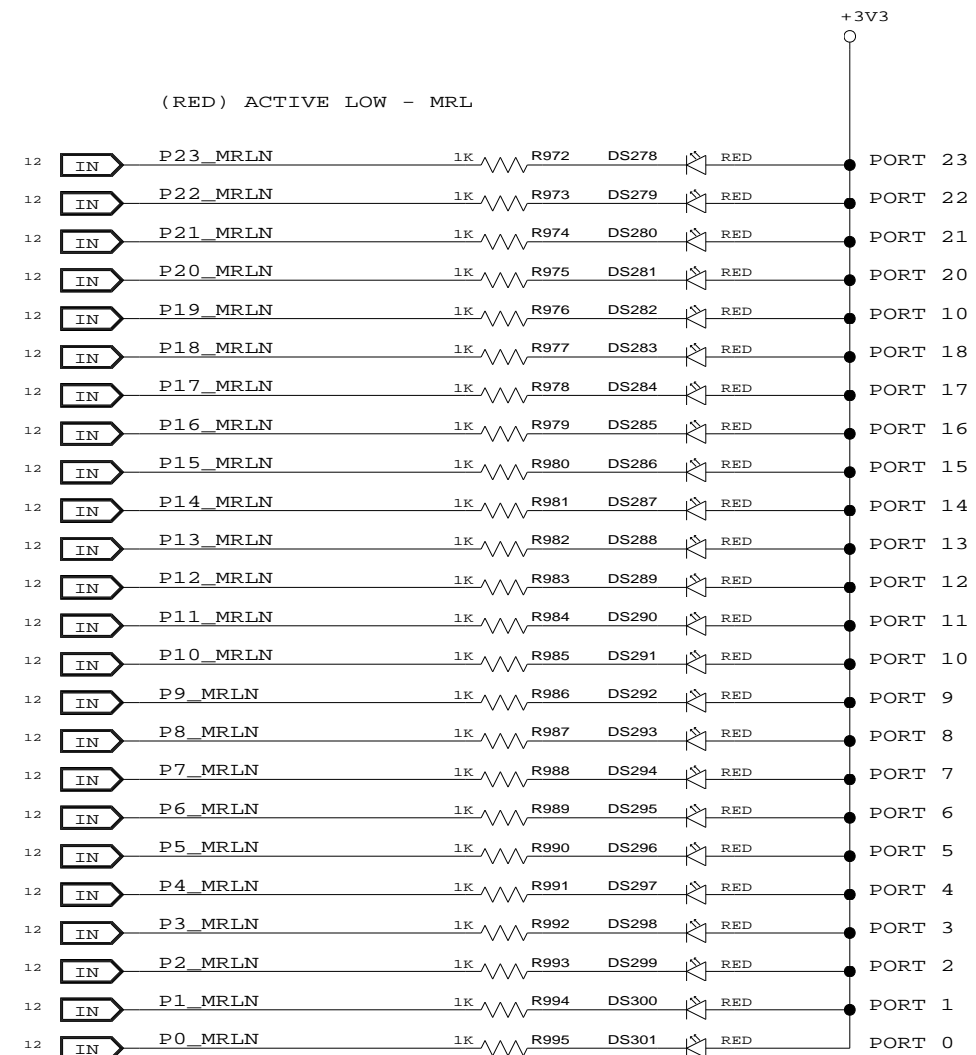
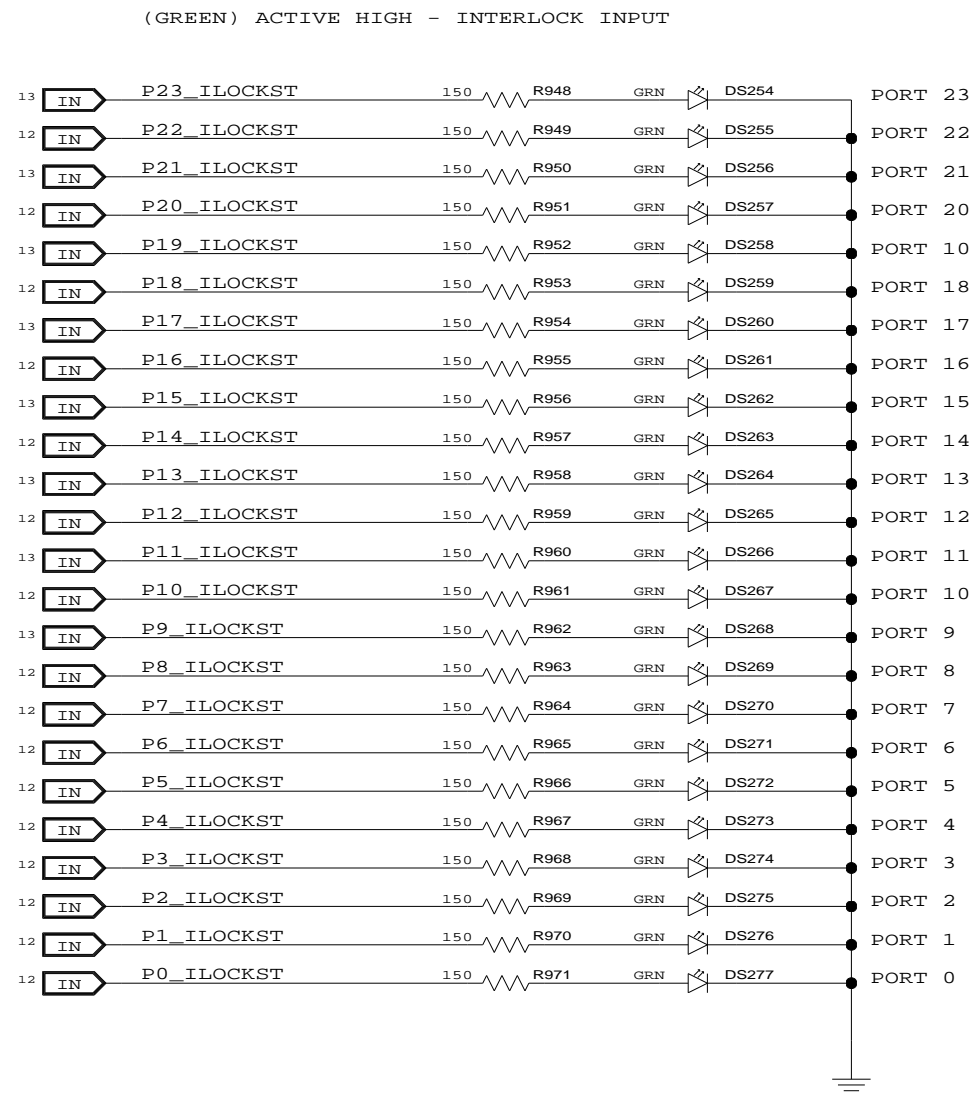

CONFIDENTIAL PROPERTY OF INTEGRATED DEVICE TECHNOLOGY, INC.
6024 SILVER CREEK VALLEY ROAD. SAN JOSE, CA 95138
COPYRIGHT (C) 2010 IDT

TITLE EB-LOGAN-23

LED - PORT STATUS (5 OF 7)

SIZE B	DRAWING NO. SCH-PESEB-001	FAB P/N 18-691-001	REV. 2.0
-----------	------------------------------	-----------------------	-------------

AUTHOR Tony Tran	CHECKED BY Derek Huang
---------------------	---------------------------

Thu Jul 01 15:01:03 2010

SHEET 38 OF 52

(RED) ACTIVE LOW - PARTITION FUND. RESET

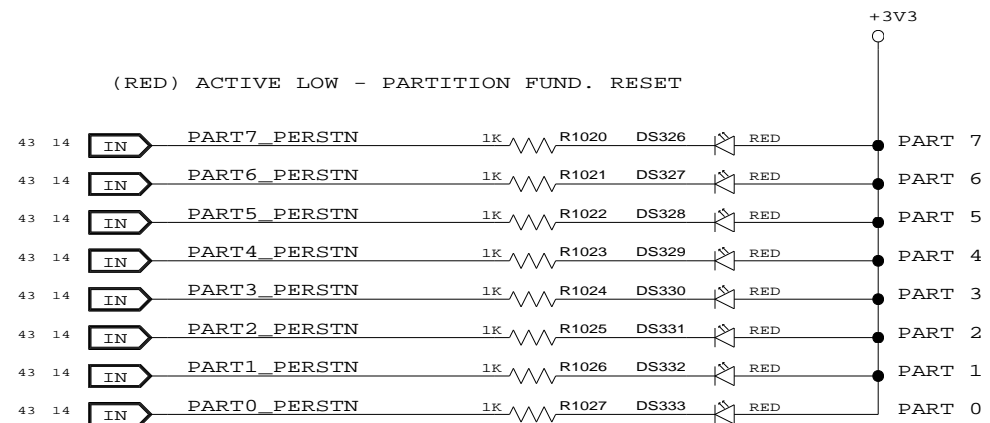

(RED) ACTIVE LOW - SLOT HEADER RESET

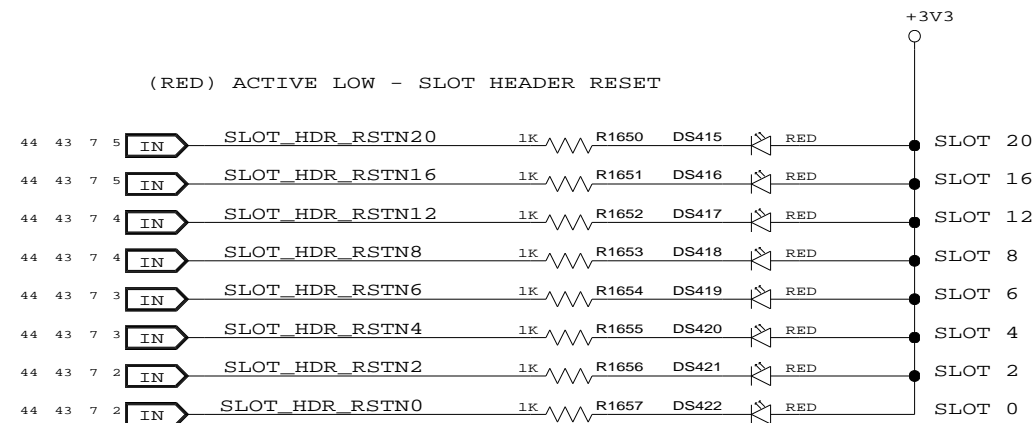

(GREEN) ACTIVE HIGH - INTERLOCK OUTPUT

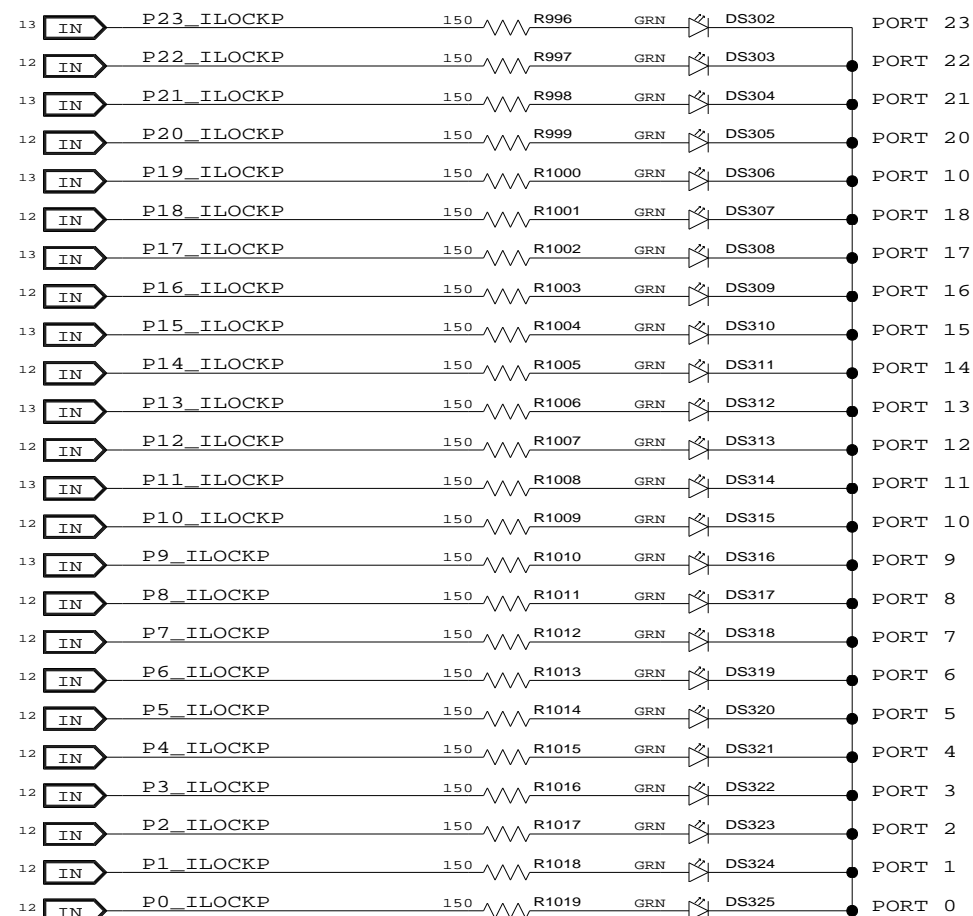

CONFIDENTIAL PROPERTY OF INTEGRATED DEVICE TECHNOLOGY, INC.
6024 SILVER CREEK VALLEY ROAD. SAN JOSE, CA 95138
COPYRIGHT (C) 2010 IDT

TITLE EB-LOGAN-23

LED - PORT STATUS (6 OF 7)

SIZE B	DRAWING NO. SCH-PESEB-001	FAB P/N 18-691-001	REV. 2.0
-----------	------------------------------	-----------------------	-------------

AUTHOR Tony Tran	CHECKED BY Derek Huang
---------------------	---------------------------

Thu Jul 01 15:01:03 2010

SHEET 39 OF 52

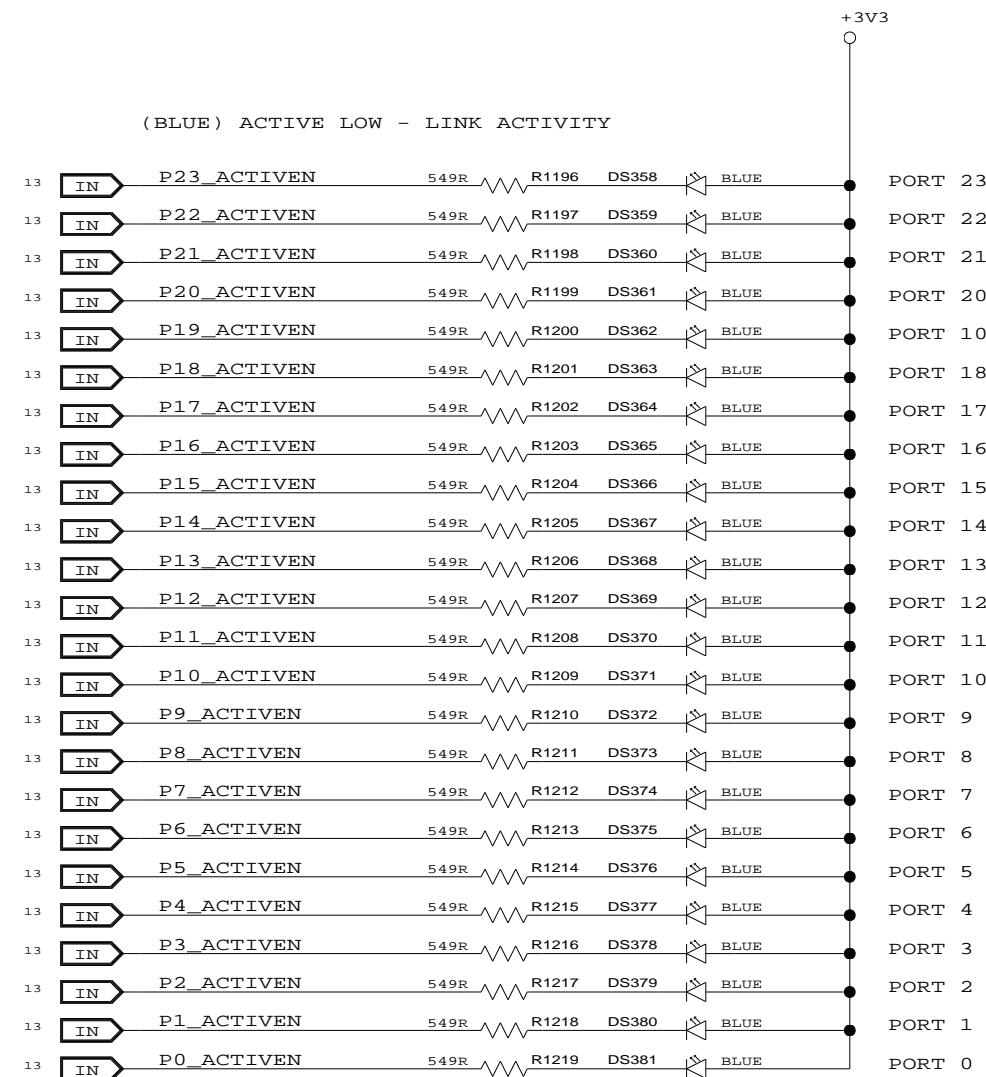
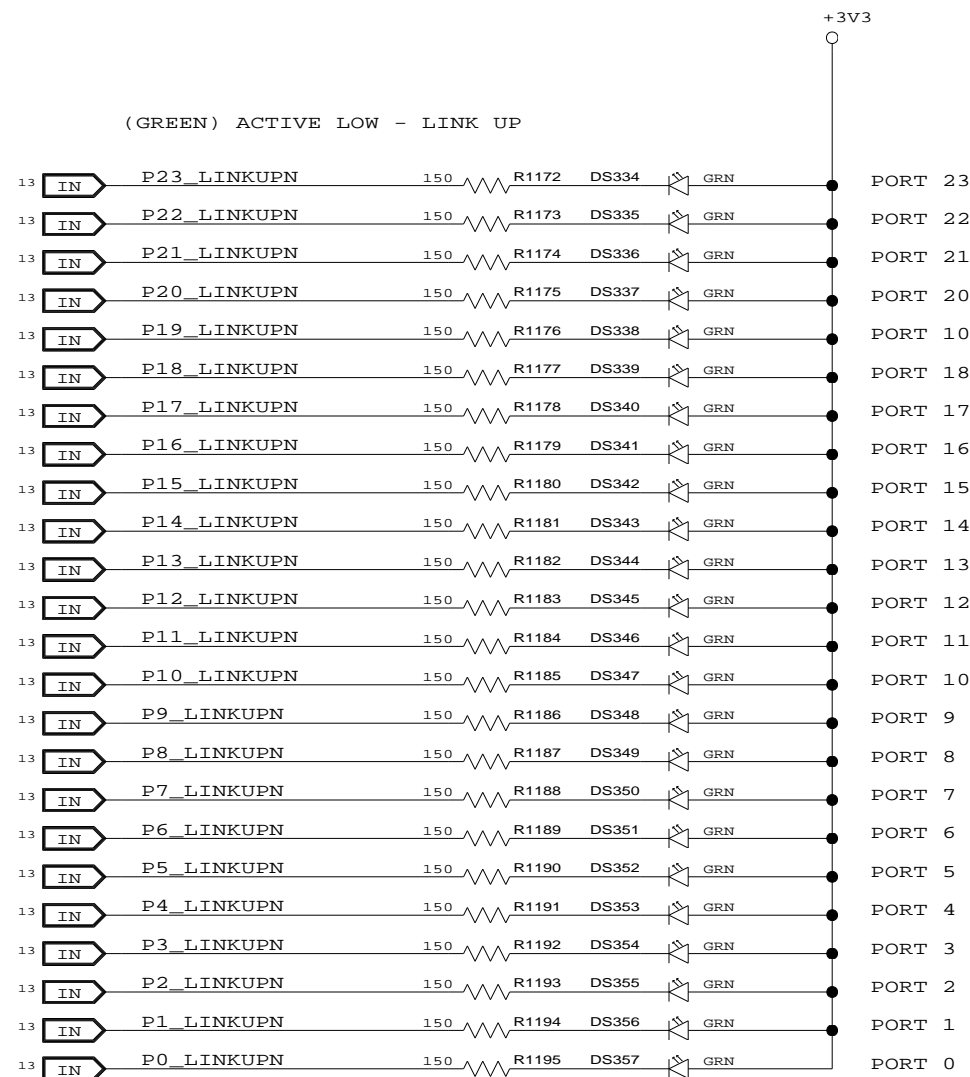

CONFIDENTIAL PROPERTY OF INTEGRATED DEVICE TECHNOLOGY, INC.
6024 SILVER CREEK VALLEY ROAD, SAN JOSE, CA 95138
COPYRIGHT (C) 2010 IDT

TITLE EB-LOGAN-23

LED - PORT STATUS (7 OF 7)

SIZE B	DRAWING NO. SCH-PESEB-001	FAB P/N 18-691-001	REV. 2.0
-----------	------------------------------	-----------------------	-------------

AUTHOR Tony Tran	CHECKED BY Derek Huang
---------------------	---------------------------

Thu Jul 01 15:01:04 2010

SHEET 40 OF 52

MINIMUM POWER SUPPLY LOADS

NOTE: DNP JUMPERS WHEN IOEXPANDER IS ENABLED

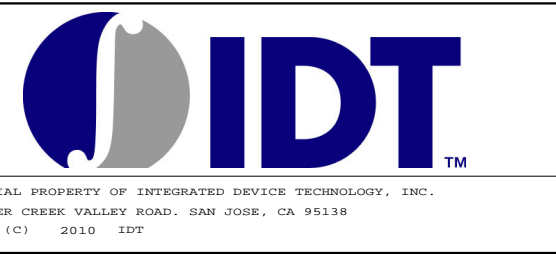
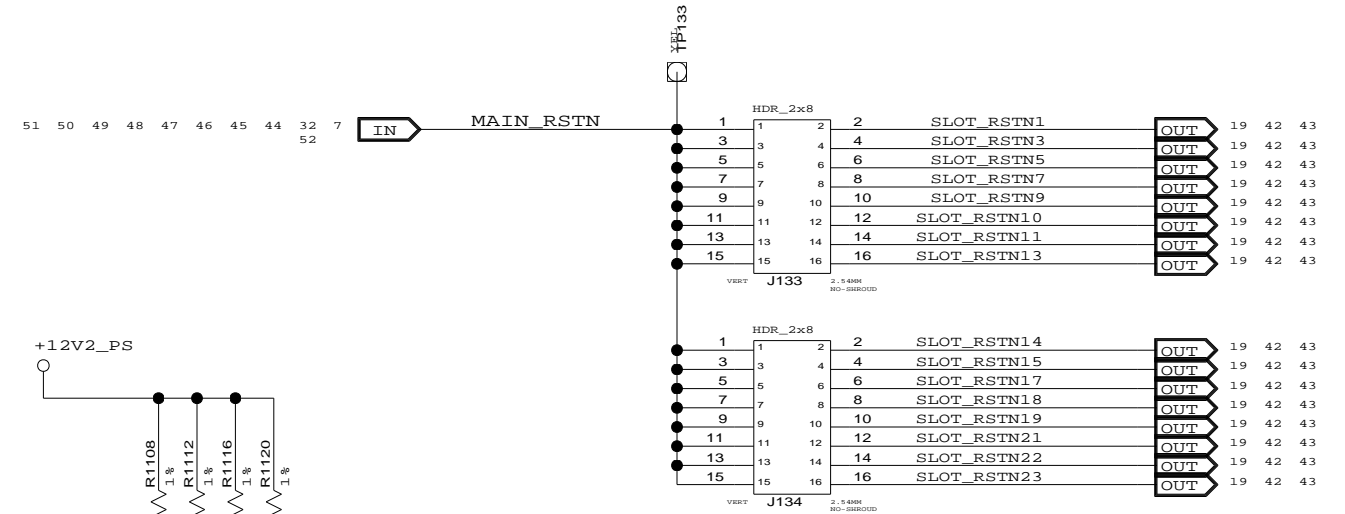
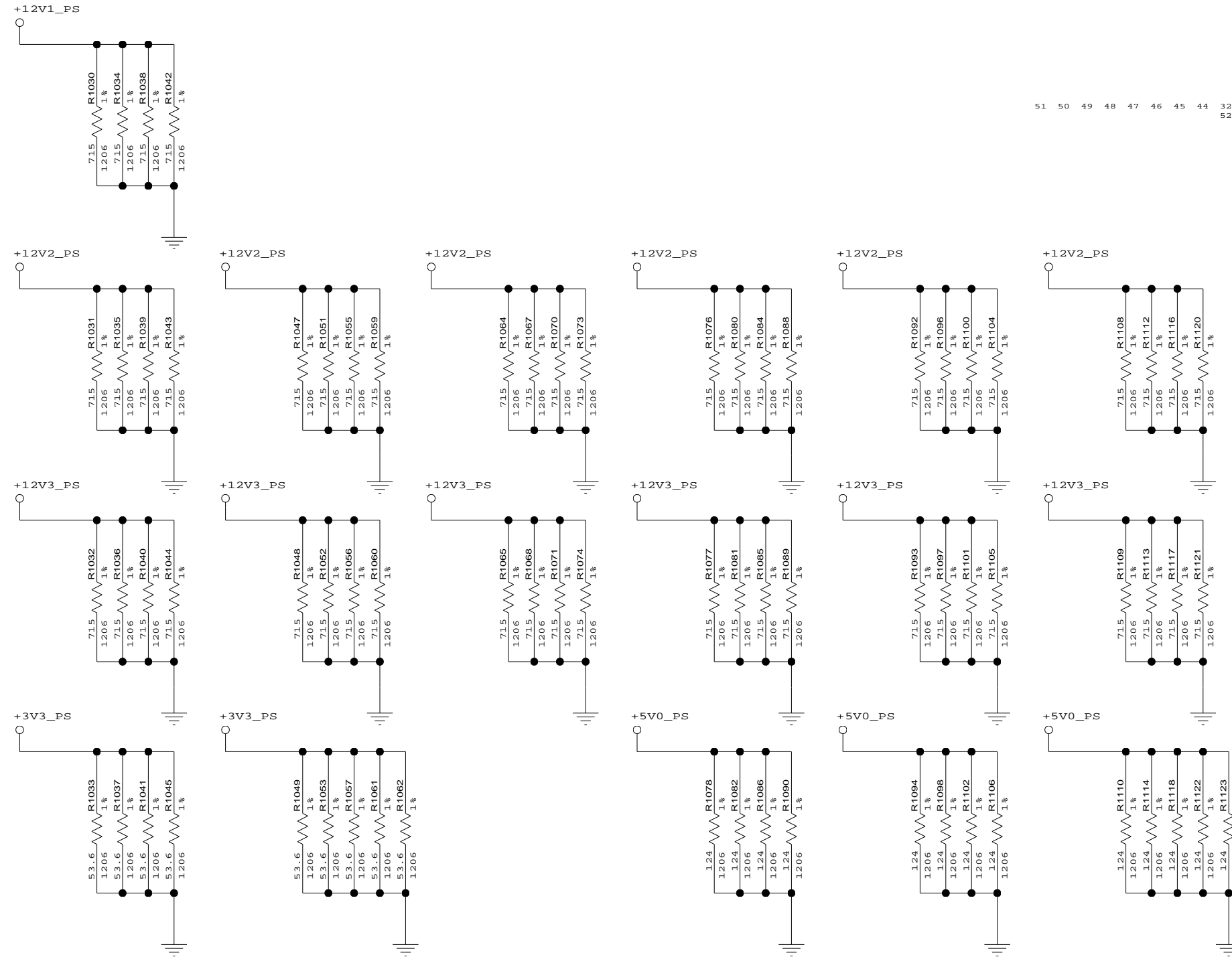

TITLE EB-LOGAN-23			
MIN LOAD RESISTORS			
SIZE B	DRAWING NO. SCH-PESEB-001	FAB P/N 18-691-001	REV. 2.0
AUTHOR Tony Tran		CHECKED BY Derek Huang	
Thu Jul 01 15:01:04 2010			SHEET 41 OF 52

SLOT_RESETN
CARD_PRESENTN
WAKEN
POWERGOOD
PWR_FLTN
PWR_ENABLE
CLOCK_ENABLEN

PS_ENABLEN
CABLE SENSE

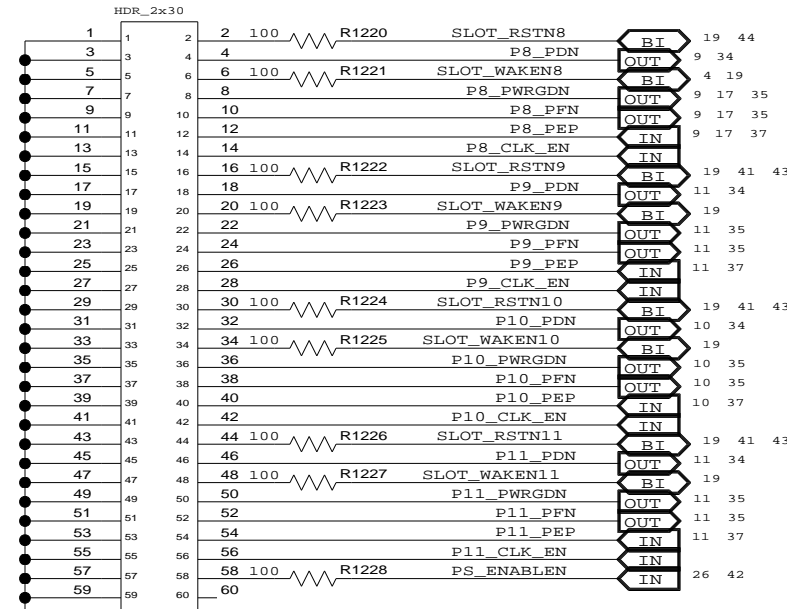

PORTS 8,9,10,11

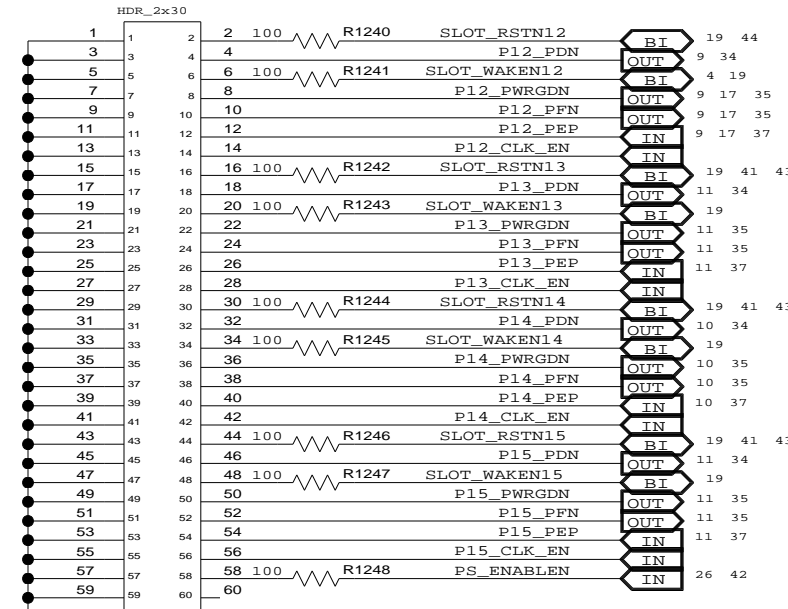

PORTS 12,13,14,15

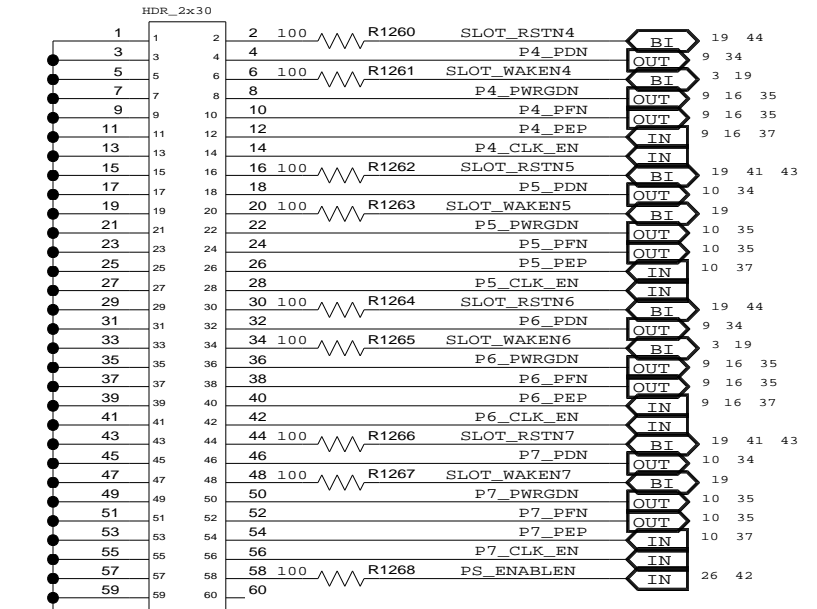

PORTS 4,5,6,7

SLOT_RESETN
CARD_PRESENTN
WAKEN
POWERGOOD
PWR_FLTN
PWR_ENABLE
CLOCK_ENABLEN

PS_ENABLEN
CABLE SENSE

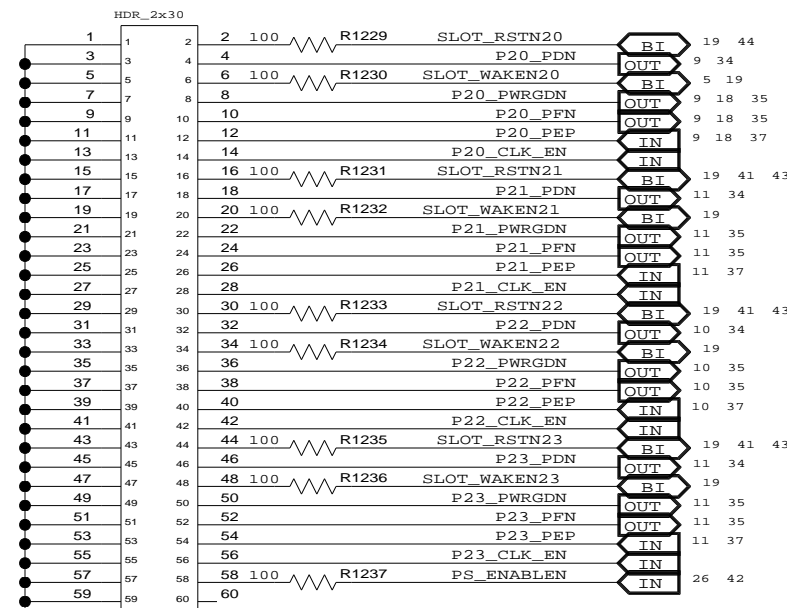

PORTS 20,21,22,23

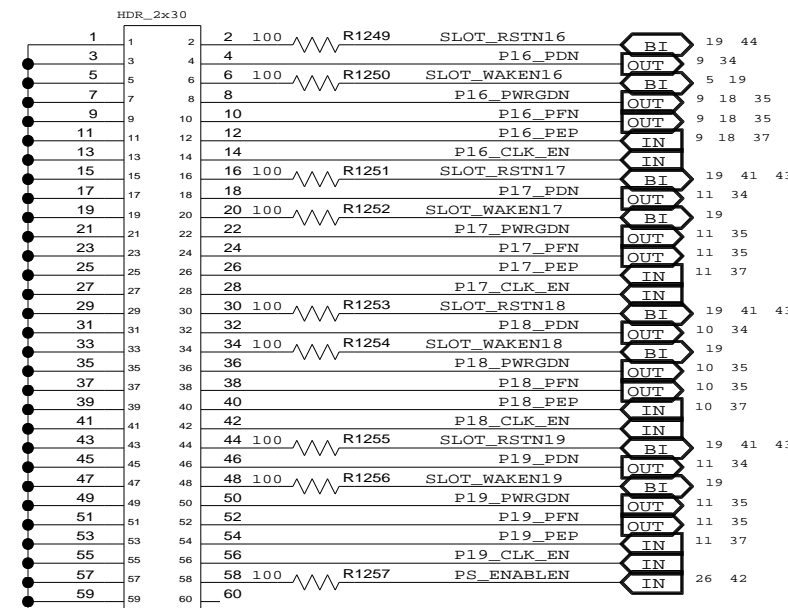

PORTS 16,17,18,19

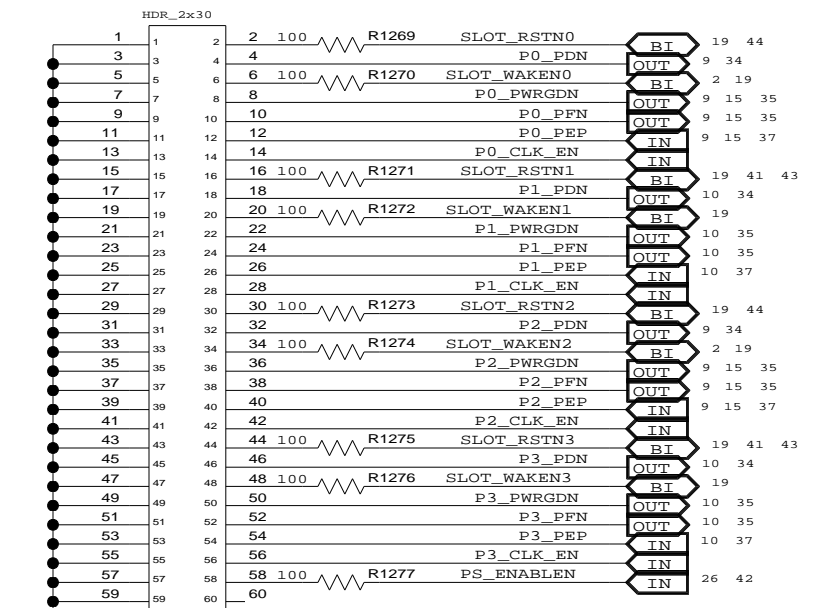

PORTS 0,1,2,3

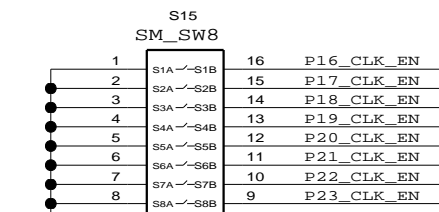
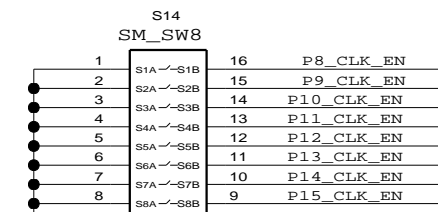
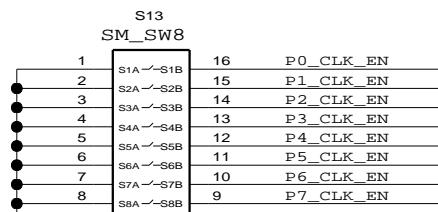

CONFIDENTIAL PROPERTY OF INTEGRATED DEVICE TECHNOLOGY, INC.
6024 SILVER CREEK VALLEY ROAD, SAN JOSE, CA 95138
COPYRIGHT (C) 2010 IDT

TITLE EB-LOGAN-23

SIDEBAND CONNECTORS

SIZE	DRAWING NO.	FAB P/N	REV.
B	SCH-PESEB-001	18-691-001	2.0
AUTHOR		CHECKED BY	
Tony Tran		Derek Huang	
Thu Jul 01 15:01:04 2010			SHEET 42 OF 52

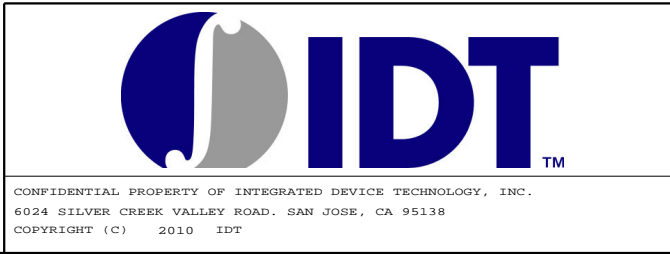
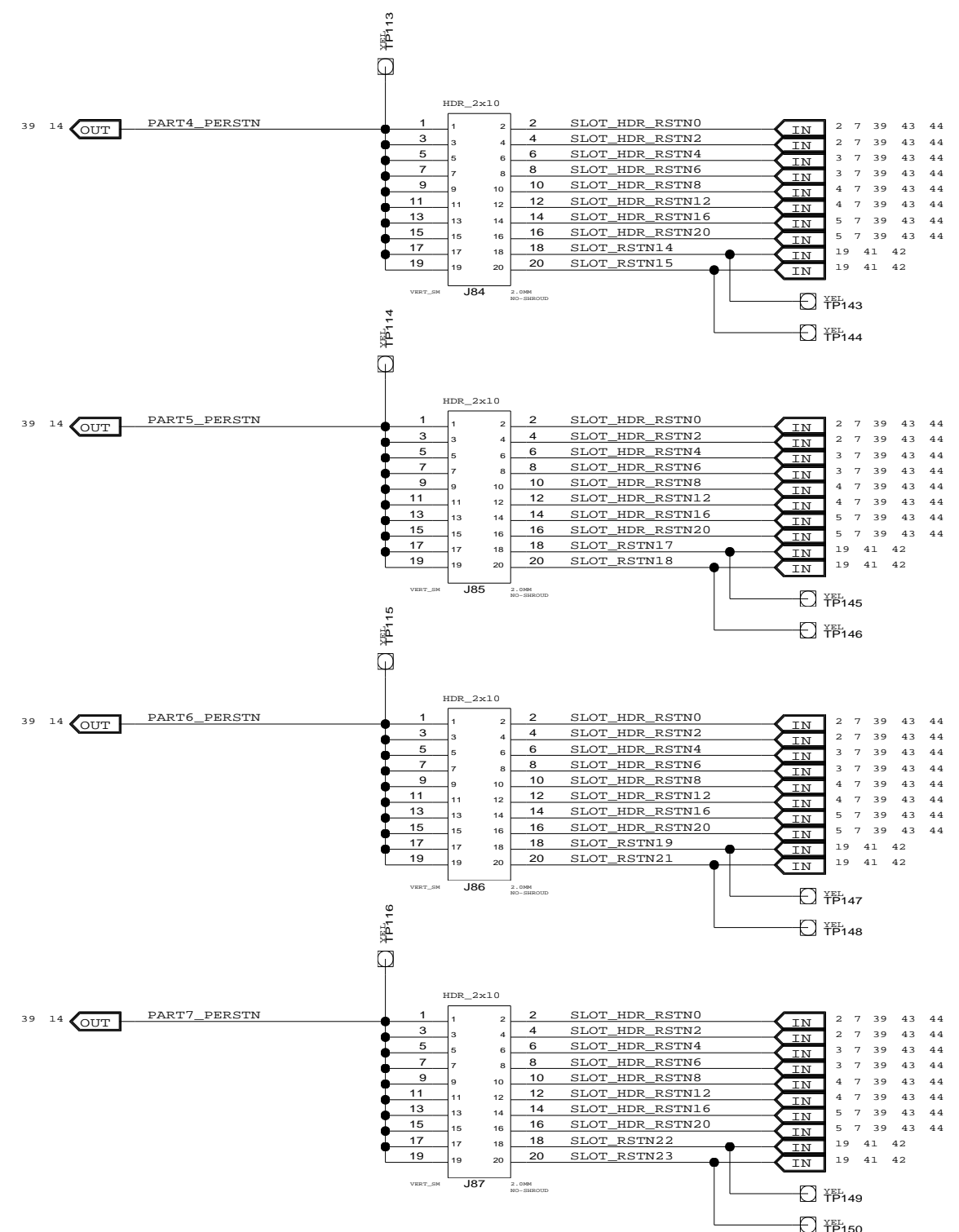
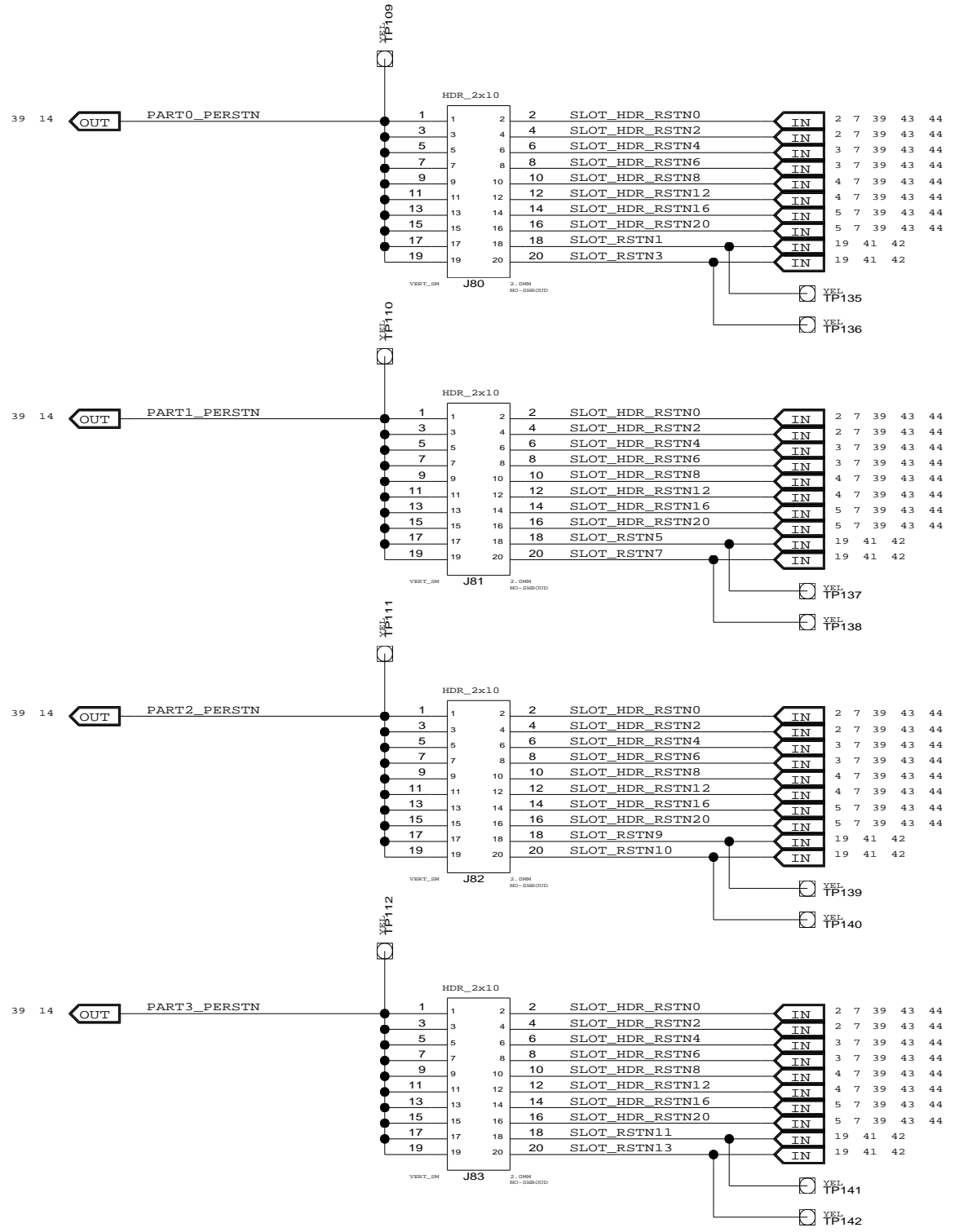

TITLE EB-LOGAN-23			
PARTITION RESET SELECT HEADERS			
SIZE	DRAWING NO.	FAB P/N	REV.
B	SCH-PESEB-001	18-691-001	2.0
AUTHOR		CHECKED BY	
Tony Tran		Derek Huang	
Thu Jul 01 15:01:05 2010			SHEET 43 OF 52

D

D

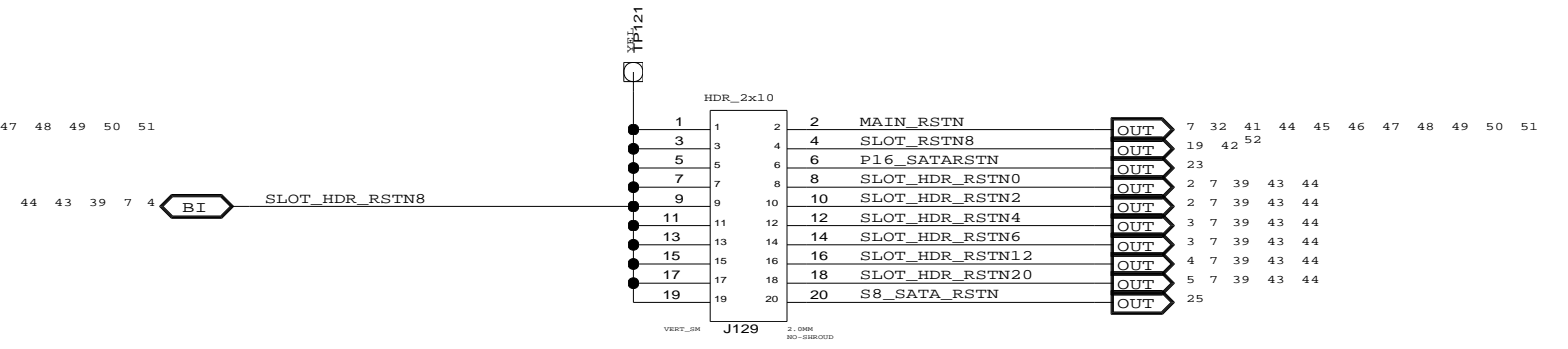
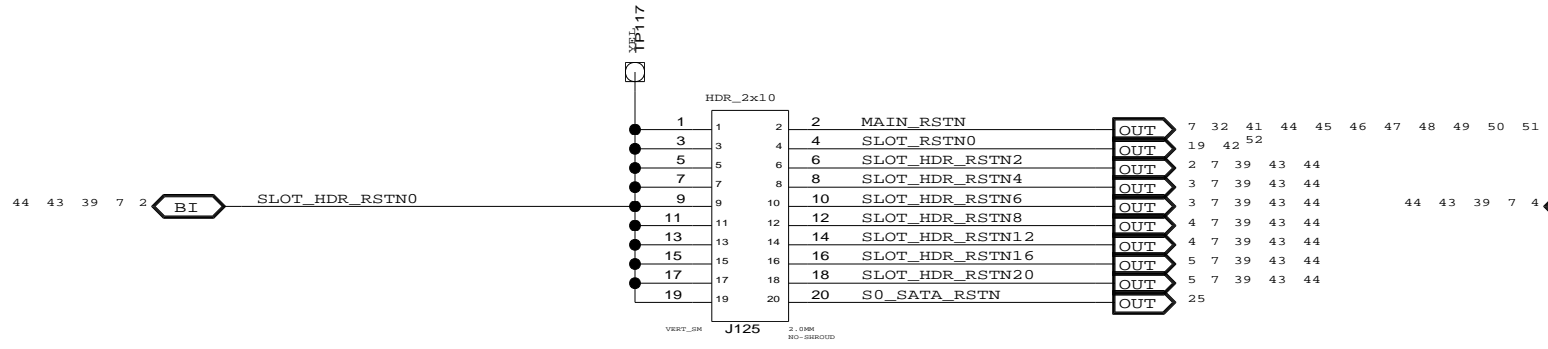

C

C

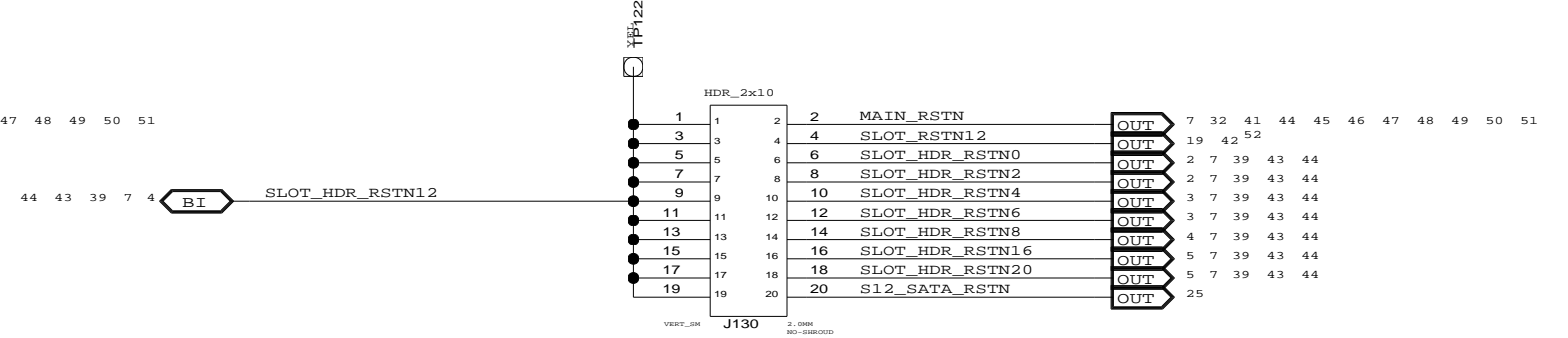
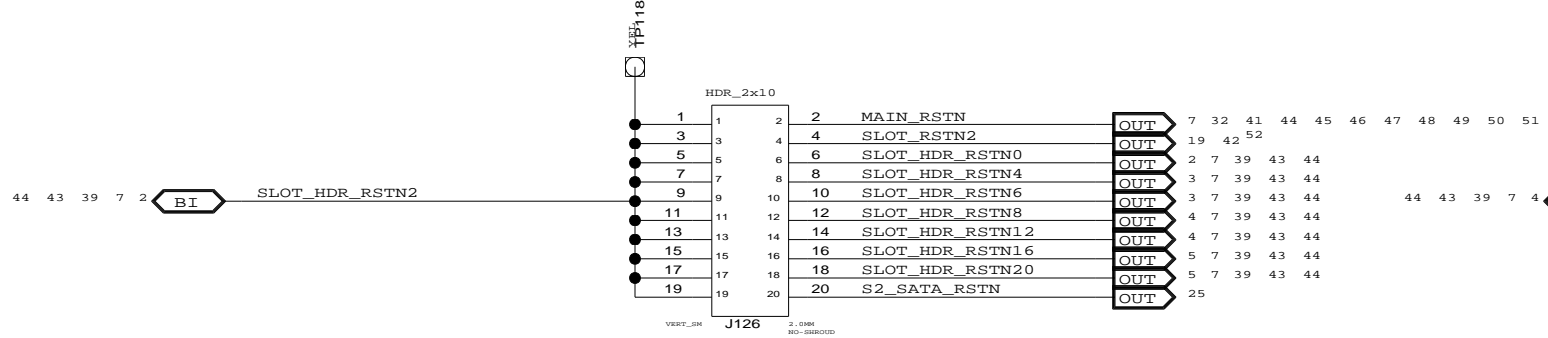

B

B

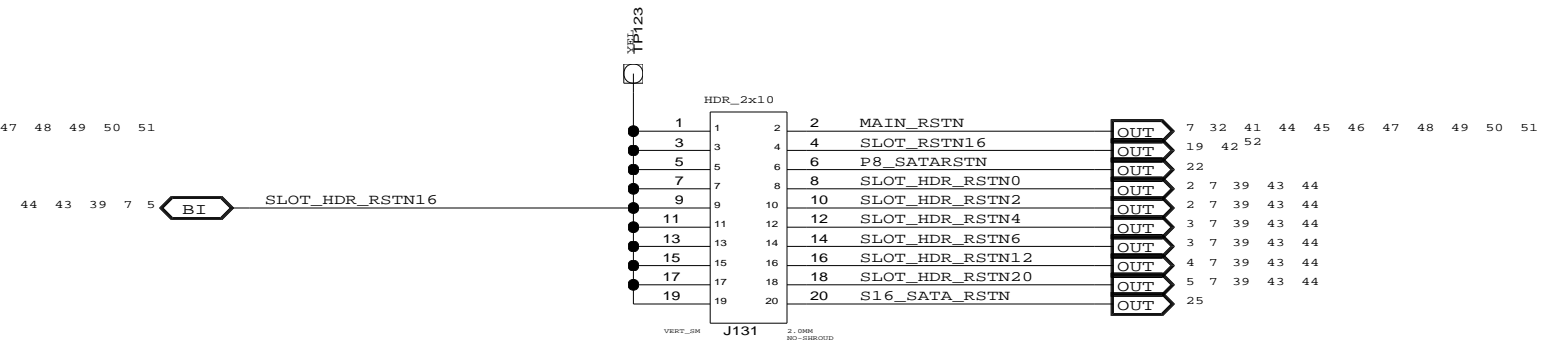
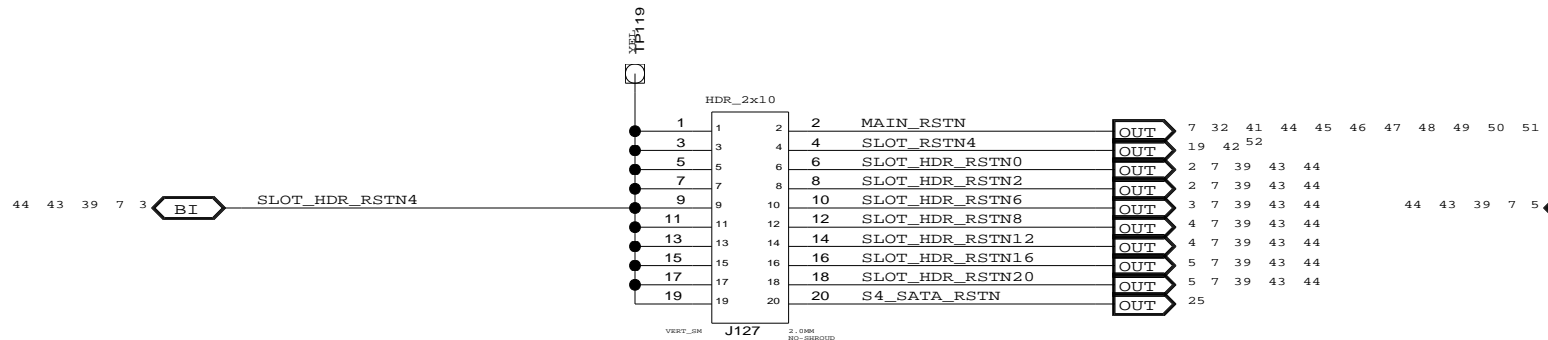

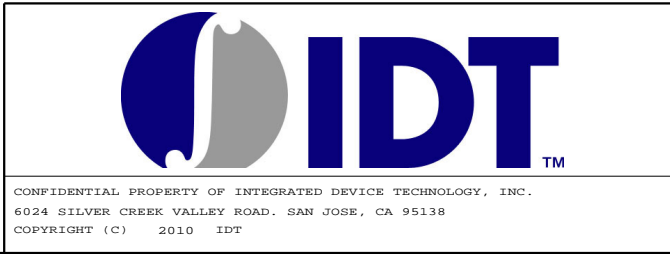
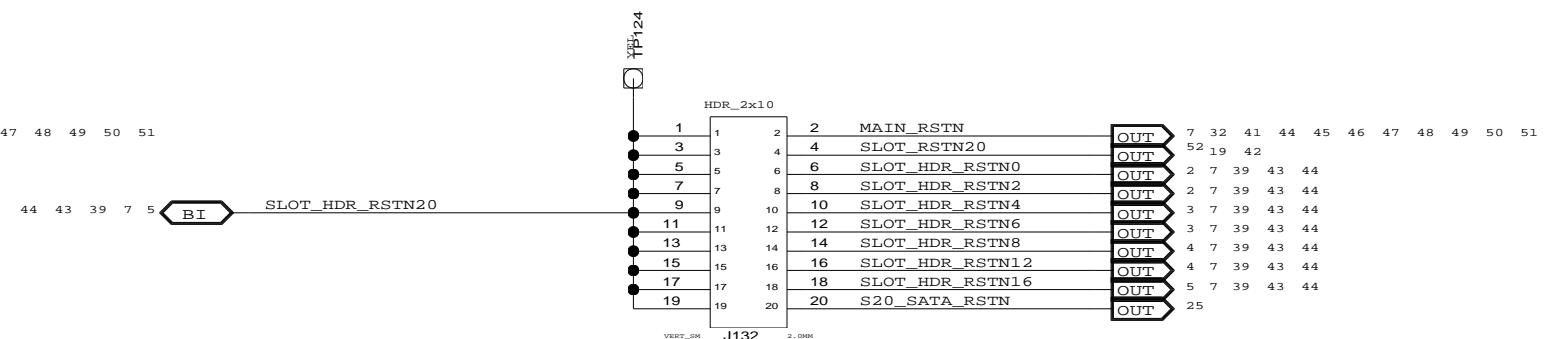
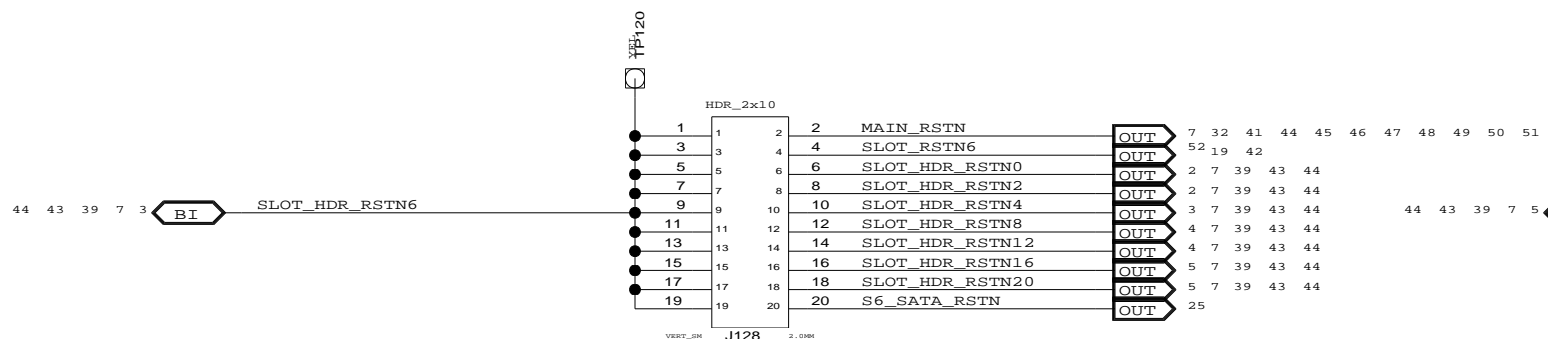

A

A

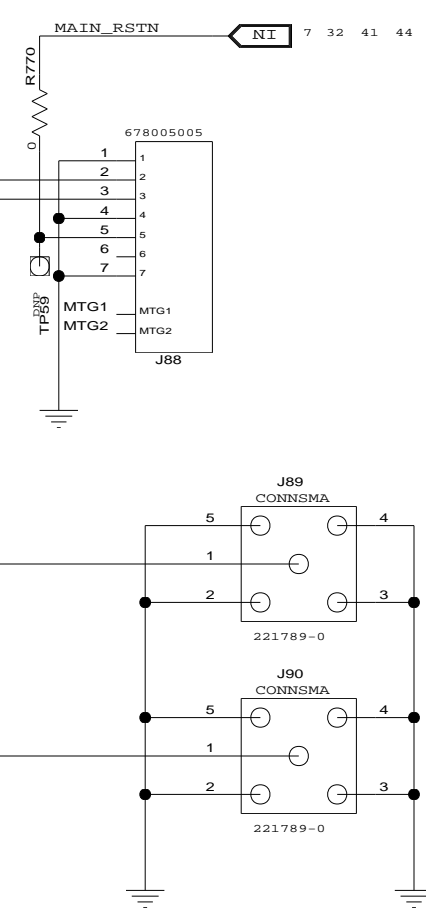
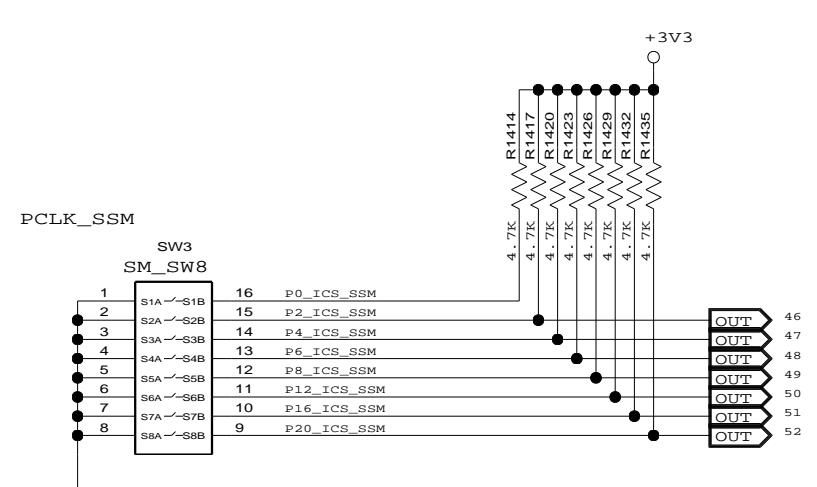
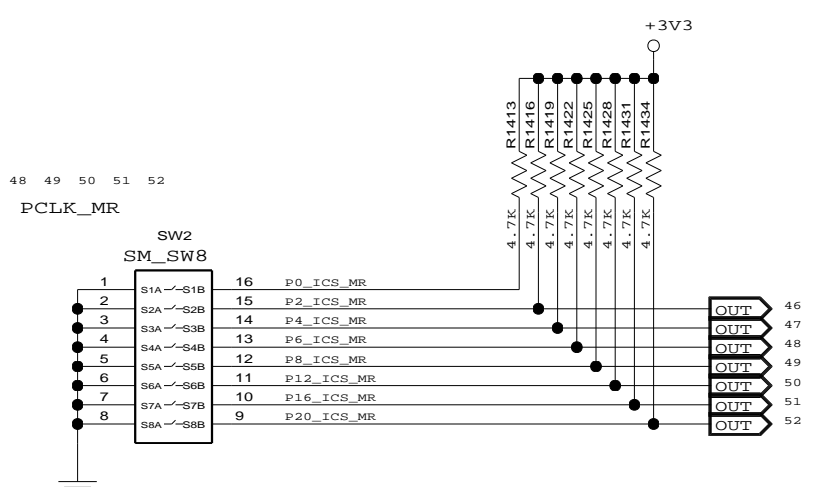
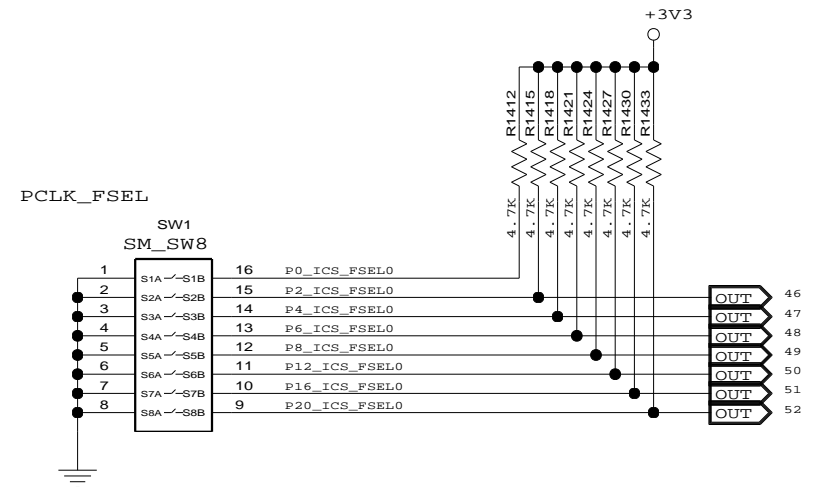
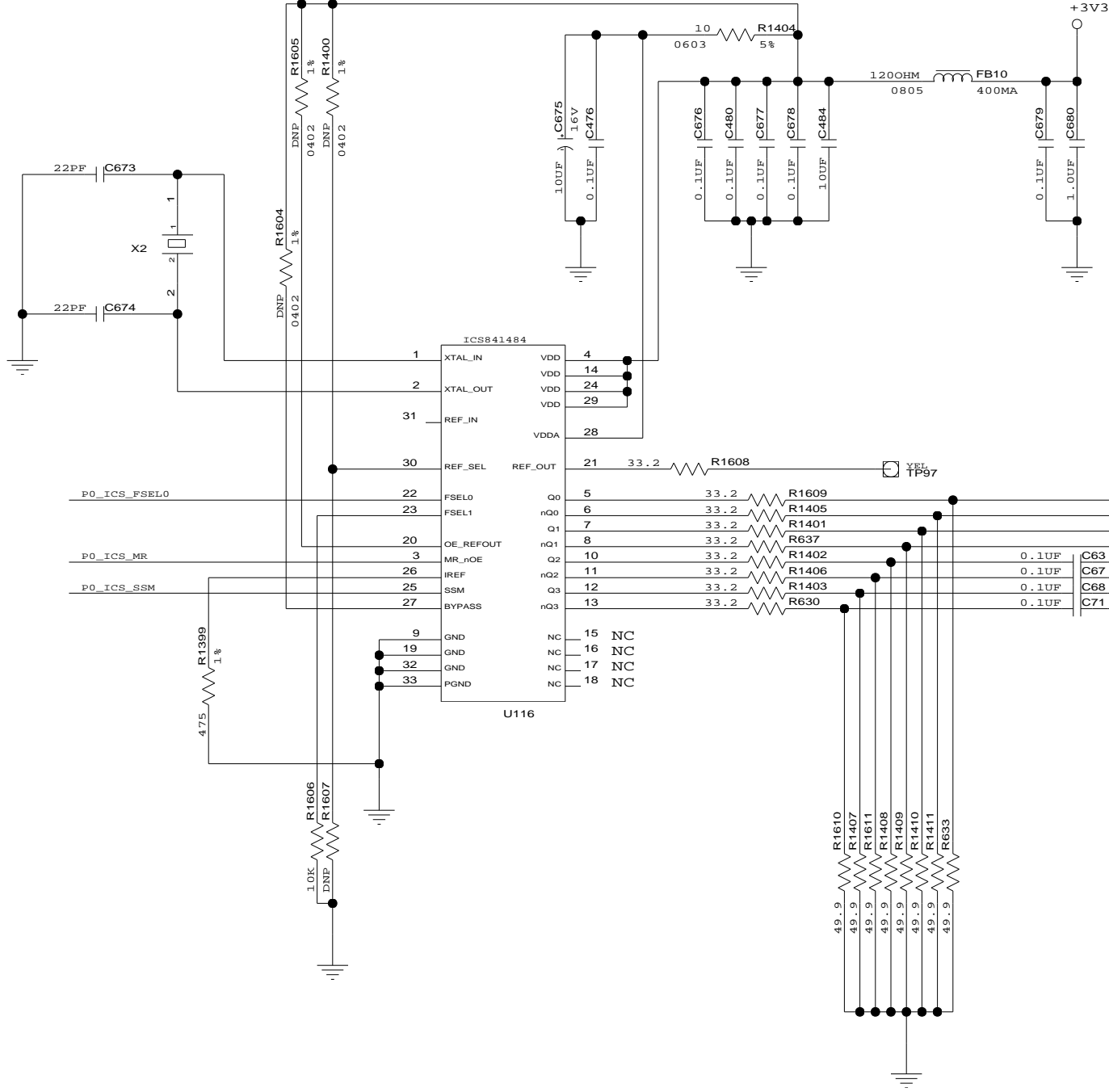

TITLE EB-LOGAN-23			
SLOT RESET SELECT HEADERS			
SIZE	DRAWING NO.	FAB P/N	REV.
B	SCH-PESEB-001	18-691-001	2.0
AUTHOR		CHECKED BY	
Tony Tran		Derek Huang	
Thu Jul 01 15:01:05 2010			SHEET 44 OF 52





CONFIDENTIAL PROPERTY OF INTEGRATED DEVICE TECHNOLOGY, INC.
6024 SILVER CREEK VALLEY ROAD, SAN JOSE, CA 95138
COPYRIGHT (C) 2010 IDT

TITLE EB-LOGAN-23

PORT 0 CLOCK GENERATOR

SIZE	DRAWING NO.	FAB P/N	REV.
B	SCH-PESEB-001	18-691-001	2.0
AUTHOR		CHECKED BY	
Tony Tran		Derek Huang	
Thu Jul 01 15:01:05 2010			SHEET 45 OF 52

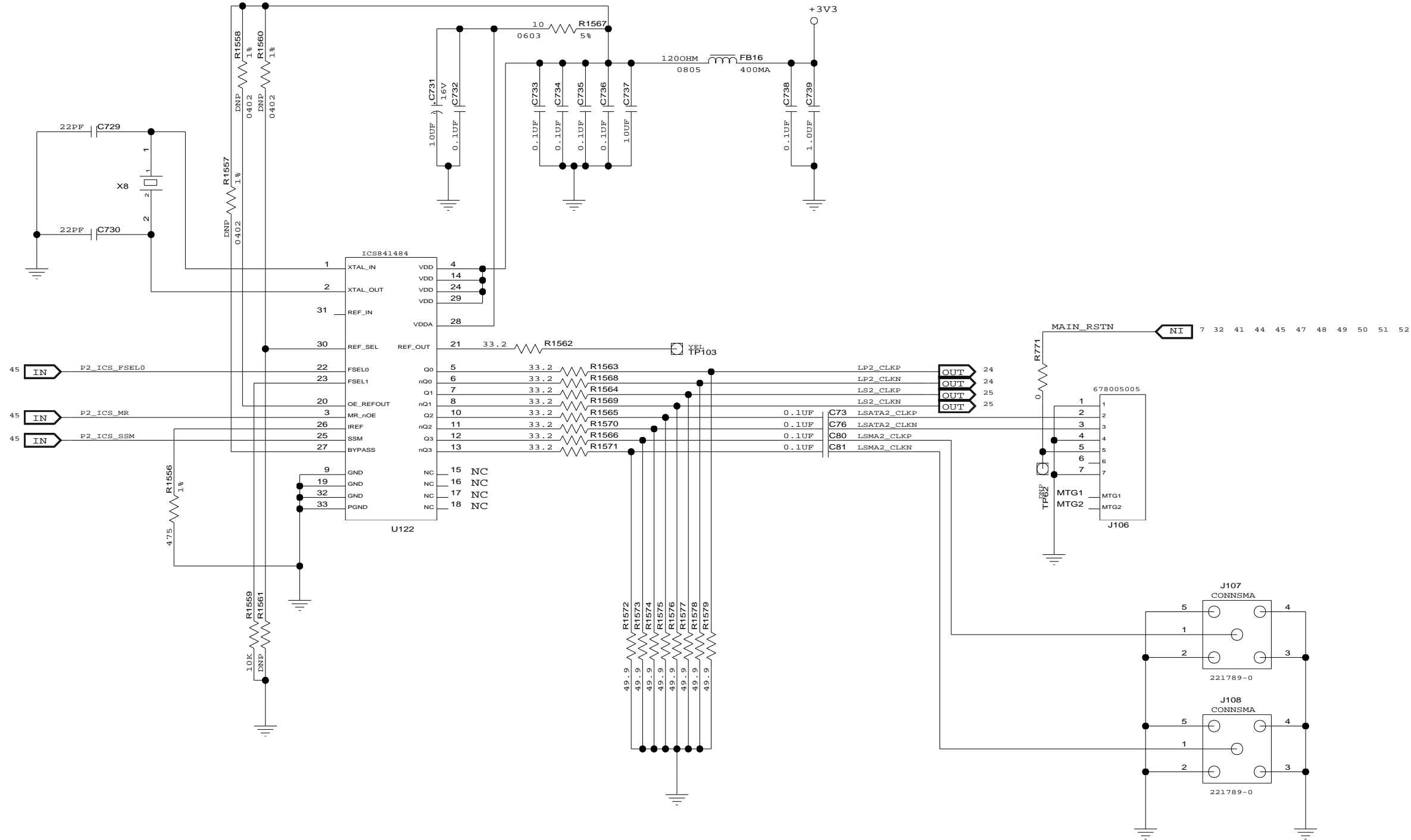

CONFIDENTIAL PROPERTY OF INTEGRATED DEVICE TECHNOLOGY, INC.
6024 SILVER CREEK VALLEY ROAD, SAN JOSE, CA 95138
COPYRIGHT (C) 2010 IDT

TITLE EB-LOGAN-23

PORT 2 CLOCK GENERATOR

SIZE B	DRAWING NO. SCH-PESEB-001	FAB P/N 18-691-001	REV. 2.0
AUTHOR Tony Tran		CHECKED BY Derek Huang	
Thu Jul 01 15:01:06 2010			SHEET 46 OF 52

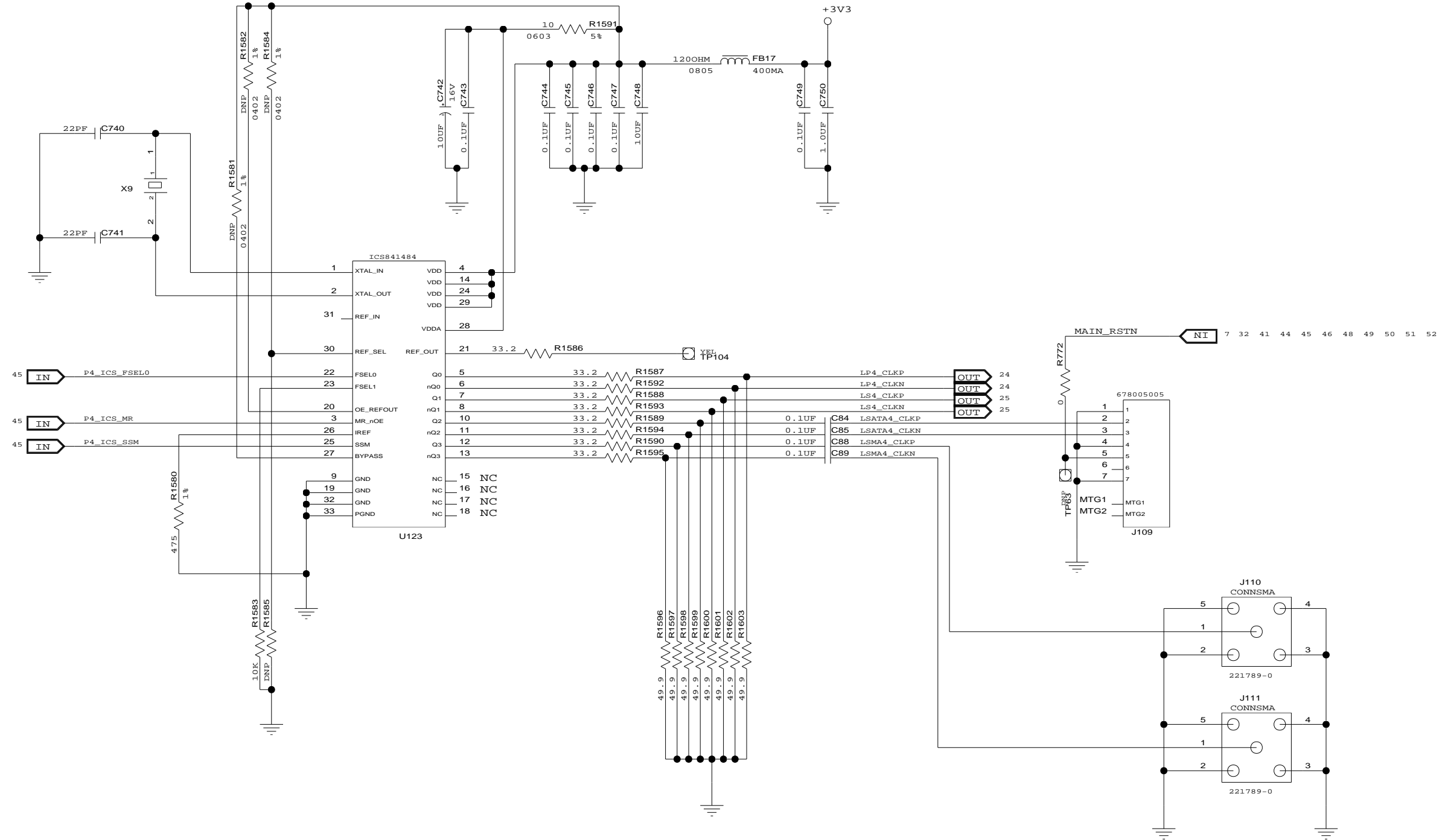

CONFIDENTIAL PROPERTY OF INTEGRATED DEVICE TECHNOLOGY, INC.
6024 SILVER CREEK VALLEY ROAD, SAN JOSE, CA 95138
COPYRIGHT (C) 2010 IDT

TITLE EB-LOGAN-23

PORT 4 CLOCK GENERATOR

SIZE B	DRAWING NO. SCH-PESEB-001	FAB P/N 18-691-001	REV. 2.0
AUTHOR Tony Tran		CHECKED BY Derek Huang	
Thu Jul 01 15:01:06 2010			SHEET 47 OF 52

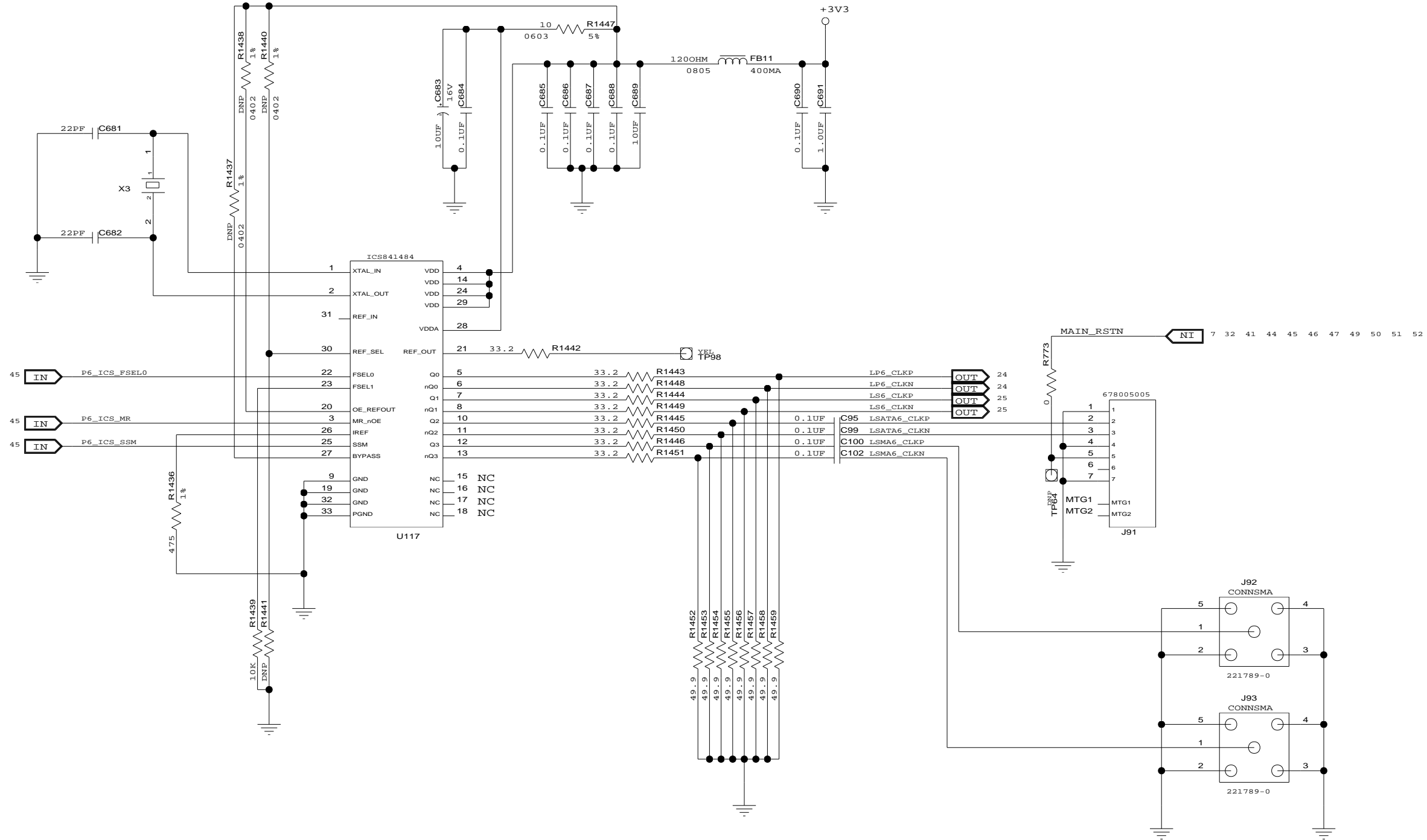

CONFIDENTIAL PROPERTY OF INTEGRATED DEVICE TECHNOLOGY, INC.
6024 SILVER CREEK VALLEY ROAD, SAN JOSE, CA 95138
COPYRIGHT (C) 2010 IDT

TITLE EB-LOGAN-23

PORT 6 CLOCK GENERATOR

SIZE B	DRAWING NO. SCH-PESEB-001	FAB P/N 18-691-001	REV. 2.0
AUTHOR Tony Tran		CHECKED BY Derek Huang	
Thu Jul 01 15:01:06 2010			SHEET 48 OF 52

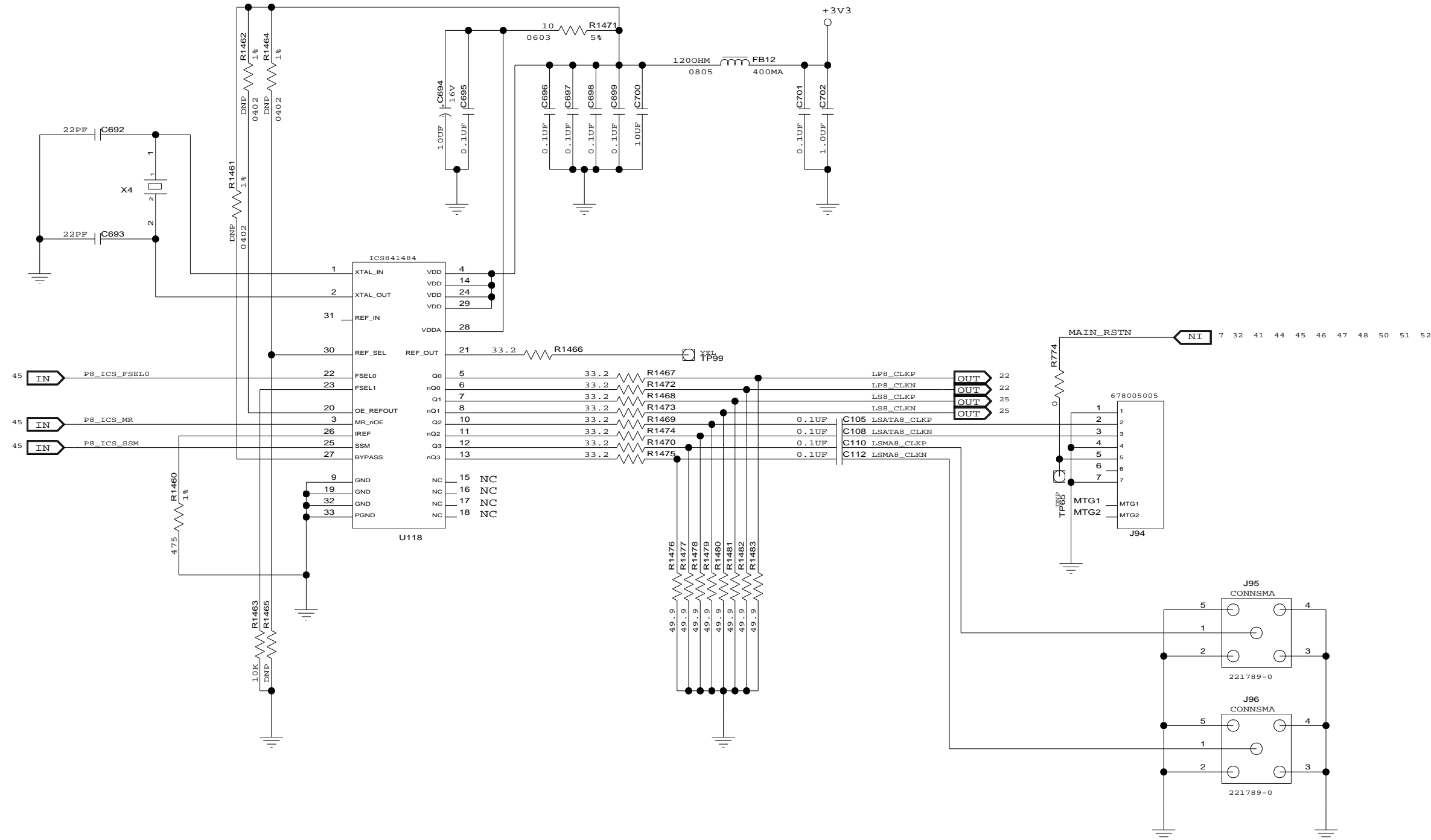

CONFIDENTIAL PROPERTY OF INTEGRATED DEVICE TECHNOLOGY, INC.
6024 SILVER CREEK VALLEY ROAD, SAN JOSE, CA 95138
COPYRIGHT (C) 2010 IDT

TITLE EB-LOGAN-23			
PORT 8 CLOCK GENERATOR			
SIZE B	DRAWING NO. SCH-PESEB-001	FAB P/N 18-691-001	REV. 2.0
AUTHOR Tony Tran		CHECKED BY Derek Huang	
Thu Jul 01 15:01:06 2010			SHEET 49 OF 52

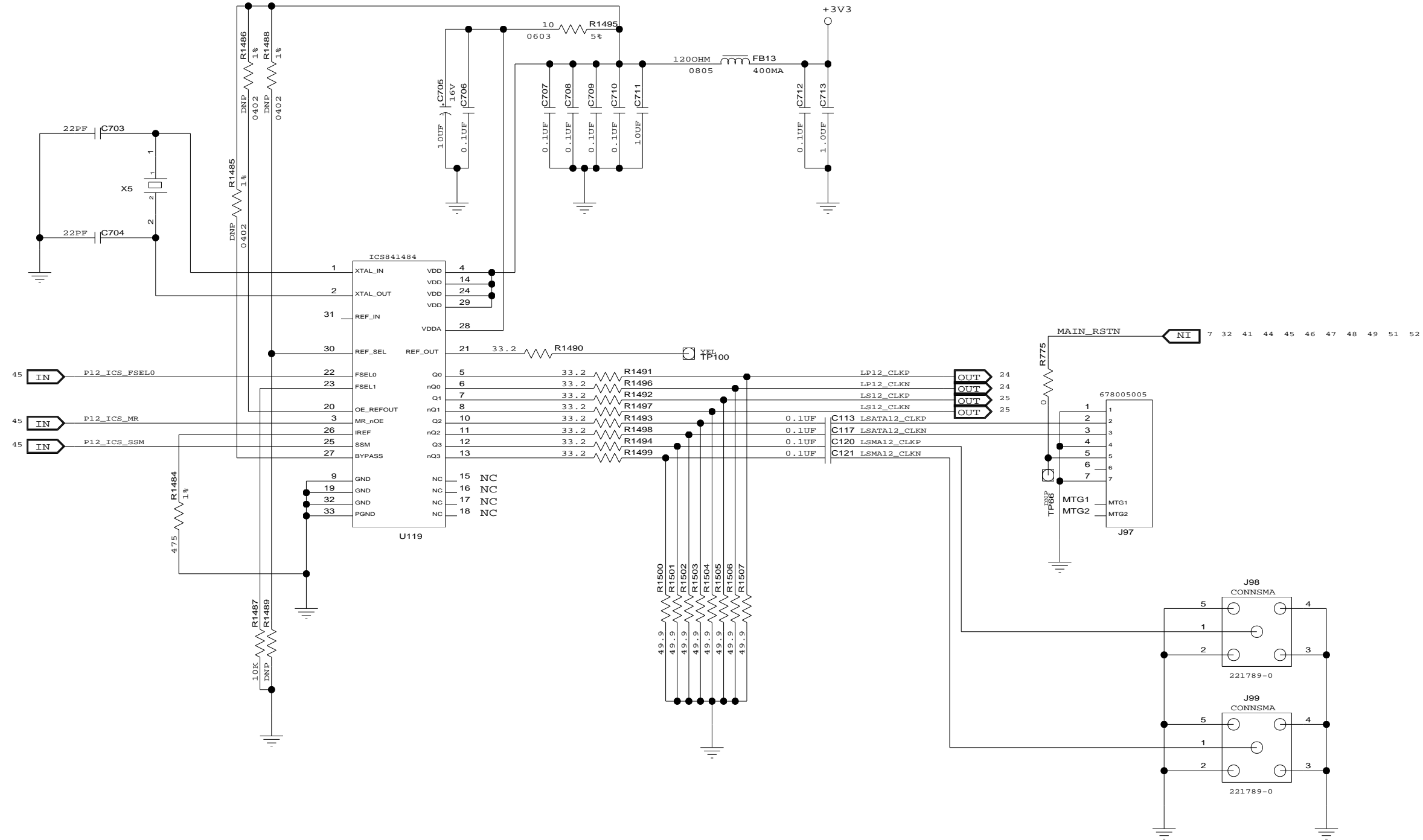



CONFIDENTIAL PROPERTY OF INTEGRATED DEVICE TECHNOLOGY, INC.
6024 SILVER CREEK VALLEY ROAD, SAN JOSE, CA 95138
COPYRIGHT (C) 2010 IDT

TITLE EB-LOGAN-23

PORT 12 CLOCK GENERATOR

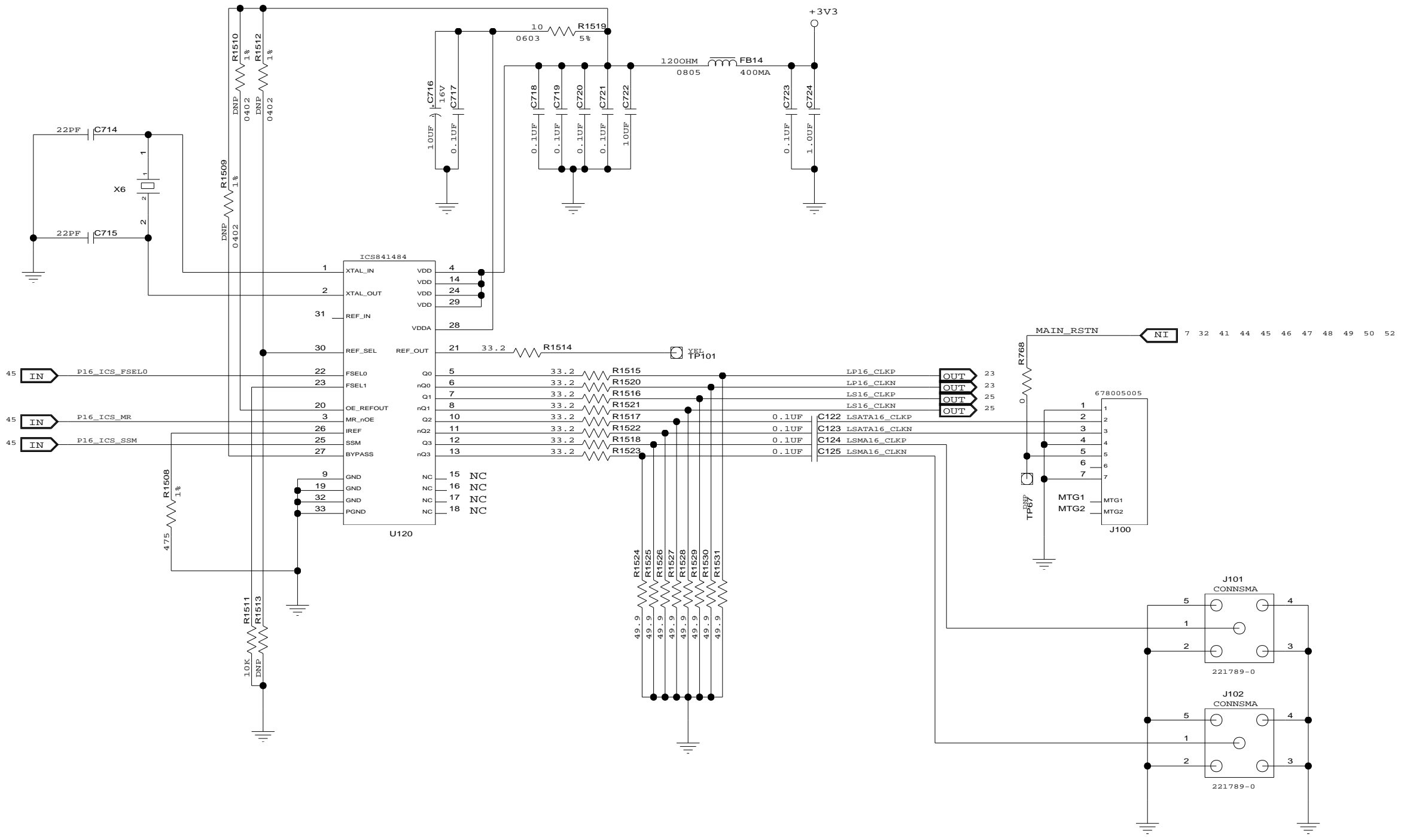
SIZE B	DRAWING NO. SCH-PESEB-001	FAB P/N 18-691-001	REV. 2.0
AUTHOR Tony Tran		CHECKED BY Derek Huang	
Thu Jul 01 15:01:07 2010			SHEET 50 OF 52



		TITLE EB-LOGAN-23	
		PORT 16 CLOCK GENERATOR	
SIZE B	DRAWING NO. SCH-PESEB-001	FAB P/N 18-691-001	REV. 2.0
AUTHOR Tony Tran		CHECKED BY Derek Huang	
CONFIDENTIAL PROPERTY OF INTEGRATED DEVICE TECHNOLOGY, INC. 6024 SILVER CREEK VALLEY ROAD. SAN JOSE, CA 95138 COPYRIGHT (C) 2010 IDT		Thu Jul 01 15:01:07 2010 SHEET 51 OF 52	

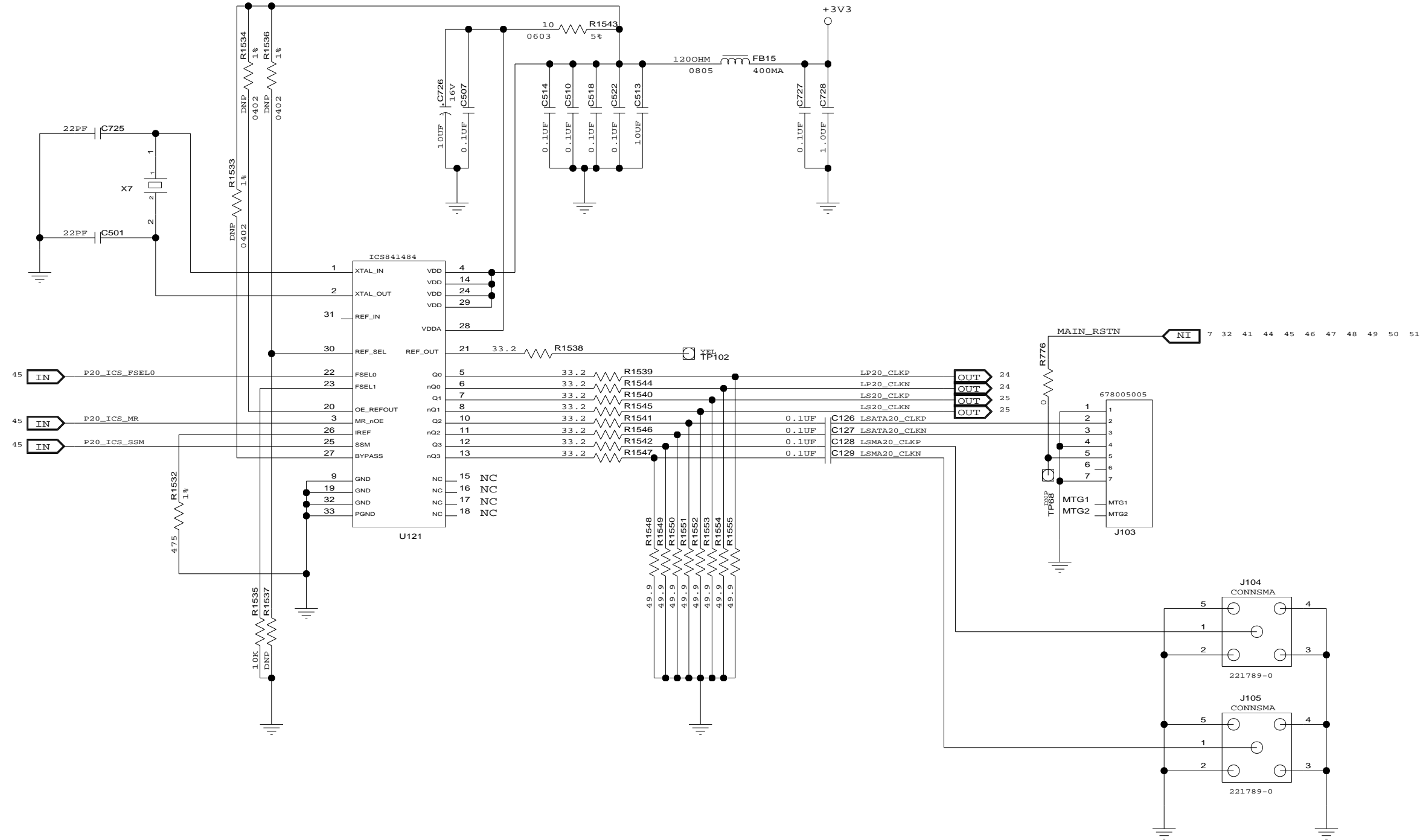

CONFIDENTIAL PROPERTY OF INTEGRATED DEVICE TECHNOLOGY, INC.
6024 SILVER CREEK VALLEY ROAD. SAN JOSE, CA 95138
COPYRIGHT (C) 2010 IDT

TITLE EB-LOGAN-23

PORT 20 CLOCK GENERATOR

SIZE B	DRAWING NO. SCH-PESEB-001	FAB P/N 18-691-001	REV. 2.0
AUTHOR Tony Tran		CHECKED BY Derek Huang	
Thu Jul 01 15:01:07 2010			SHEET 52 OF 52

IMPORTANT NOTICE AND DISCLAIMER

RENESAS ELECTRONICS CORPORATION AND ITS SUBSIDIARIES (“RENESAS”) PROVIDES TECHNICAL SPECIFICATIONS AND RELIABILITY DATA (INCLUDING DATASHEETS), DESIGN RESOURCES (INCLUDING REFERENCE DESIGNS), APPLICATION OR OTHER DESIGN ADVICE, WEB TOOLS, SAFETY INFORMATION, AND OTHER RESOURCES “AS IS” AND WITH ALL FAULTS, AND DISCLAIMS ALL WARRANTIES, EXPRESS OR IMPLIED, INCLUDING, WITHOUT LIMITATION, ANY IMPLIED WARRANTIES OF MERCHANTABILITY, FITNESS FOR A PARTICULAR PURPOSE, OR NON-INFRINGEMENT OF THIRD-PARTY INTELLECTUAL PROPERTY RIGHTS.

These resources are intended for developers who are designing with Renesas products. You are solely responsible for (1) selecting the appropriate products for your application, (2) designing, validating, and testing your application, and (3) ensuring your application meets applicable standards, and any other safety, security, or other requirements. These resources are subject to change without notice. Renesas grants you permission to use these resources only to develop an application that uses Renesas products. Other reproduction or use of these resources is strictly prohibited. No license is granted to any other Renesas intellectual property or to any third-party intellectual property. Renesas disclaims responsibility for, and you will fully indemnify Renesas and its representatives against, any claims, damages, costs, losses, or liabilities arising from your use of these resources. Renesas' products are provided only subject to Renesas' Terms and Conditions of Sale or other applicable terms agreed to in writing. No use of any Renesas resources expands or otherwise alters any applicable warranties or warranty disclaimers for these products.

(Disclaimer Rev.1.01 Jan 2024)

Corporate Headquarters

TOYOSU FORESIA, 3-2-24 Toyosu,
Koto-ku, Tokyo 135-0061, Japan
www.renesas.com

Trademarks



Renesas and the Renesas logo are trademarks of Renesas Electronics Corporation. All trademarks and registered trademarks are the property of their respective owners.

Contact Information

For further information on a product, technology, the most up-to-date version of a document, or your nearest sales office, please visit www.renesas.com/contact-us/.

Looking for pricing, stock, or lifecycle information?

Click below to explore more details on WIN SOURCE:

-  [View 89H32NT24BG2ZCHLGI on WIN SOURCE](#)
-  [Renesas Electronics America](#) Information

Optimize Your Supply Chain with WIN SOURCE Solutions

-  Global Sourcing Solution
-  Obsolete Management
-  Cost Control Management
-  Shortage Management
-  Alternative Solution
-  Excess Inventory Management