



**THE DATASHEET OF  
6116LA90TDB**



Features

- ◆ High-speed access and chip select times
  - Commercial: 15/20/25ns (max.)
  - Industrial: 20/25ns (max.)
  - Military: 20/25/35/45/55/70/90/120/150ns (max.)
- ◆ Low-power consumption
- ◆ Battery backup operation
  - 2V data retention voltage (LA version only)
- ◆ Produced with advanced CMOS high-performance technology
- ◆ CMOS process virtually eliminates alpha particle soft-error rates
- ◆ Input and output directly TTL-compatible
- ◆ Static operation: no clocks or refresh required
- ◆ Available in ceramic 24-pin DIP, ceramic and plastic 24-pin Thin Dip and 24-pin SOIC
- ◆ Military product compliant to MIL-STD-883, Class B
- ◆ Industrial temperature range (-40°C to +85°C) is available for selected speeds
- ◆ Green parts available, see ordering information

Description

The IDT6116SA/LA is a 16,384-bit high-speed static RAM organized as 2K x 8. It is fabricated using high-performance, high-reliability CMOS technology.

Access times as fast as 15ns are available. The circuit also offers a reduced power standby mode. When  $\overline{CS}$  goes HIGH, the circuit will automatically go to, and remain in, a standby power mode, as long as  $\overline{CS}$  remains HIGH. This capability provides significant system level power and cooling savings. The low-power (LA) version also offers a battery backup data retention capability where the circuit typically consumes only 1µW to 4µW operating off a 2V battery.

All inputs and outputs of the IDT6116SA/LA are TTL-compatible. Fully static asynchronous circuitry is used, requiring no clocks or refreshing for operation.

The IDT6116SA/LA is packaged in 24-pin 300mil plastic DIP, 24-pin 600mil and 300mil ceramic DIP, or 24-lead gull-wing SOIC providing high board-level packing densities.

Military grade product is manufactured in compliance to MIL-STD-883, Class B, making it ideally suited to military temperature applications demanding the highest level of performance and reliability.

Functional Block Diagram

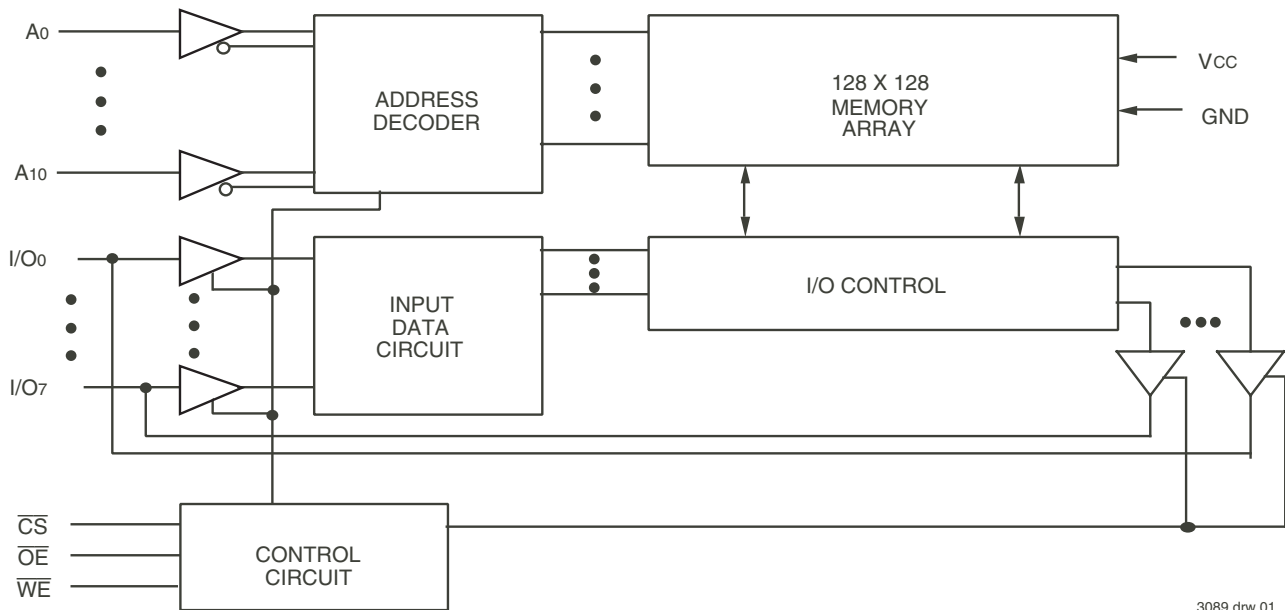

## Pin Configurations<sup>(1)</sup>

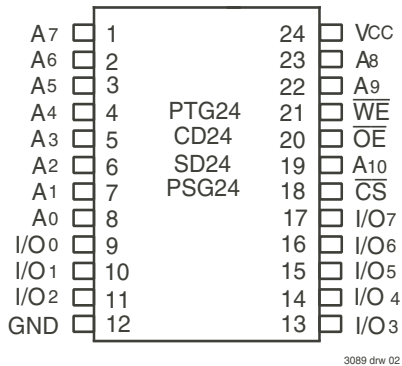

DIP/SOIC  
Top View

**NOTE:**

1. This text does not indicate orientation of actual part-marking.

## Pin Description

Name	Description
A <sub>0</sub> - A <sub>10</sub>	Address Inputs
I/O <sub>0</sub> - I/O <sub>7</sub>	Data Input/Output
$\overline{CS}$	Chip Select
$\overline{WE}$	Write Enable
$\overline{OE}$	Output Enable
V <sub>CC</sub>	Power
GND	Ground

3089 tbl 01

## Truth Table<sup>(1)</sup>

Mode	$\overline{CS}$	$\overline{OE}$	$\overline{WE}$	I/O
Standby	H	X	X	High-Z
Read	L	L	H	DATA <sub>OUT</sub>
Read	L	H	H	High-Z
Write	L	X	L	DATA <sub>IN</sub>

**NOTE:**

1. H = V<sub>IH</sub>, L = V<sub>IL</sub>, X = Don't Care.

## Capacitance (T<sub>A</sub> = +25°C, f = 1.0 MHz)

Symbol	Parameter <sup>(1)</sup>	Conditions	Max.	Unit
C <sub>IN</sub>	Input Capacitance	V <sub>IN</sub> = 0V	8	pF
C <sub>VO</sub>	I/O Capacitance	V <sub>OUT</sub> = 0V	8	pF

3089 tbl 03

**NOTE:**

1. This parameter is determined by device characterization, but is not production tested.

## Absolute Maximum Ratings<sup>(1)</sup>

Symbol	Rating	Com'l.	Mil.	Unit
V <sub>TERM</sub> <sup>(2)</sup>	Terminal Voltage with Respect to GND	-0.5 to +7.0	-0.5 to +7.0	V
T <sub>A</sub>	Operating Temperature	0 to +70	-55 to +125	°C
T <sub>BIAS</sub>	Temperature Under Bias	-55 to +125	-65 to +135	°C
T <sub>STG</sub>	Storage Temperature	-55 to +125	-65 to +150	°C
P <sub>T</sub>	Power Dissipation	1.0	1.0	W
I <sub>OUT</sub>	DC Output Current	50	50	mA

3089 tbl 04

**NOTES:**

- Stresses greater than those listed under ABSOLUTE MAXIMUM RATINGS may cause permanent damage to the device. This is a stress rating only and functional operation of the device at these or any other conditions above those indicated in the operational sections of this specification is not implied. Exposure to absolute maximum rating conditions for extended periods may affect reliability.
- V<sub>TERM</sub> must not exceed V<sub>CC</sub> +0.5V.

### Recommended Operating Temperature and Supply Voltage

Grade	Ambient Temperature	GND	Vcc
Military	-55°C to +125°C	0V	5.0V ± 10%
Industrial	-40°C to +85°C	0V	5.0V ± 10%
Commercial	0°C to +70°C	0V	5.0V ± 10%

3089 tbl 05

### Recommended DC Operating Conditions

Symbol	Parameter	Min.	Typ.	Max.	Unit
Vcc	Supply Voltage	4.5	5.0	5.5 <sup>(2)</sup>	V
GND	Ground	0	0	0	V
V <sub>IH</sub>	Input High Voltage	2.2	3.5	V <sub>cc</sub> + 0.5	V
V <sub>IL</sub>	Input Low Voltage	-0.5 <sup>(1)</sup>	—	0.8	V

3089 tbl 06

**NOTES:**

- V<sub>IL</sub> (min.) = -3.0V for pulse width less than 20ns, once per cycle.
- V<sub>IN</sub> must not exceed V<sub>cc</sub> + 0.5V.

### DC Electrical Characteristics

(V<sub>cc</sub> = 5.0V ± 10%)

Symbol	Parameter	Test Conditions	IDT6116SA		IDT6116LA		Unit
			Min.	Max.	Min.	Max.	
I <sub>LI</sub>	Input Leakage Current	V <sub>cc</sub> = Max., V <sub>IN</sub> = GND to V <sub>cc</sub>	—	10 5	—	5 2	μA
I <sub>LO</sub>	Output Leakage Current	V <sub>cc</sub> = Max., $\overline{CS}$ = V <sub>IH</sub> , V <sub>OUT</sub> = GND to V <sub>cc</sub>	—	10 5	—	5 2	μA
V <sub>OL</sub>	Output Low Voltage	I <sub>OL</sub> = 8mA, V <sub>cc</sub> = Min.	—	0.4	—	0.4	V
V <sub>OH</sub>	Output High Voltage	I <sub>OH</sub> = -4mA, V <sub>cc</sub> = Min.	2.4	—	2.4	—	V

3089 tbl 07

### DC Electrical Characteristics<sup>(1)</sup>

(V<sub>cc</sub> = 5.0V ± 10%, V<sub>LC</sub> = 0.2V, V<sub>HC</sub> = V<sub>cc</sub> - 0.2V)

Symbol	Parameter	Power	6116SA15	6116SA20 6116LA20		6116SA25 6116LA25		Unit
			Com'l Only	Com'l & Ind	Mil	Com'l & Ind	Mil	
I <sub>CC1</sub>	Operating Power Supply Current CS ≤ V <sub>IL</sub> , Outputs Open V <sub>cc</sub> = Max., f = 0	SA	105	105	130	100	90	mA
		LA	—	95	120	95	85	
I <sub>CC2</sub>	Dynamic Operating Current CS ≤ V <sub>IL</sub> , Outputs Open V <sub>cc</sub> = Max., f = f <sub>MAX</sub> <sup>(2)</sup>	SA	150	130	150	120	135	mA
		LA	—	120	140	110	125	
I <sub>SB</sub>	Standby Power Supply Current (TTL Level) CS ≥ V <sub>IH</sub> , Outputs Open V <sub>cc</sub> = Max., f = f <sub>MAX</sub> <sup>(2)</sup>	SA	40	40	50	40	45	mA
		LA	—	35	45	35	40	
I <sub>SB1</sub>	Full Standby Power Supply Current (CMOS Level) CS ≥ V <sub>HC</sub> , V <sub>cc</sub> = Max., V <sub>IN</sub> ≤ V <sub>LC</sub> or V <sub>IN</sub> ≥ V <sub>HC</sub> , f = 0	SA	2	2	10	2	10	mA
		LA	—	0.1	0.9	0.1	0.9	

**NOTES:**

- All values are maximum guaranteed values.
- f<sub>MAX</sub> = 1/t<sub>rc</sub>, only address inputs are cycling at f<sub>MAX</sub>, f = 0 means address inputs are not changing.

3089 tbl 08

## DC Electrical Characteristics<sup>(1)</sup> (continued)

(V<sub>CC</sub> = 5.0V ± 10%, V<sub>LC</sub> = 0.2V, V<sub>HC</sub> = V<sub>CC</sub> - 0.2V)

Symbol	Parameter	Power	6116SA35 6116LA35	6116SA45 6116LA45	6116SA55 6116LA55	6116SA70 6116LA70	6116SA90 6116LA90	6116SA120 6116LA120	6116SA150 6116LA150	Unit
			Mil Only	Mil Only	Mil Only	Mil Only	Mil Only	Mil Only	Mil Only	
ICC1	Operating Power Supply Current, $\overline{CS} \leq V_{IL}$ , Outputs Open V <sub>CC</sub> = Max., f = 0	SA	90	90	90	90	90	90	90	mA
		LA	85	85	85	85	85	85	85	
ICC2	Dynamic Operating Current, $\overline{CS} \leq V_{IL}$ , Outputs Open V <sub>CC</sub> = Max., f = f <sub>MAX</sub> <sup>(2)</sup>	SA	115	100	100	100	100	100	90	mA
		LA	105	95	90	90	85	85	85	
ISB	Standby Power Supply Current (TTL Level) $\overline{CS} \geq V_{IH}$ , Outputs Open V <sub>CC</sub> = Max., f = f <sub>MAX</sub> <sup>(2)</sup>	SA	35	25	25	25	25	25	25	mA
		LA	30	20	20	20	25	15	15	
ISB1	Full Standby Power Supply Current (CMOS Level), $\overline{CS} \geq V_{HC}$ , V <sub>CC</sub> = Max., V <sub>IN</sub> ≤ V <sub>LC</sub> or V <sub>IN</sub> ≥ V <sub>HC</sub> , f = 0	SA	10	10	10	10	10	10	10	mA
		LA	0.9	0.9	0.9	0.9	0.9	0.9	0.9	

3089 tbl 09

### NOTES:

- All values are maximum guaranteed values.
- f<sub>MAX</sub> = 1/trc, only address inputs are toggling at f<sub>MAX</sub>, f = 0 means address inputs are not changing.

## Data Retention Characteristics Over All Temperature Ranges

(LA Version Only) (V<sub>LC</sub> = 0.2V, V<sub>HC</sub> = V<sub>CC</sub> - 0.2V)

Symbol	Parameter	Test Condition	Min.	Typ. <sup>(1)</sup> V <sub>CC</sub> @		Max. V <sub>CC</sub> @		Unit
				2.0V	3.0V	2.0V	3.0V	
VDR	V <sub>CC</sub> for Data Retention	—	2.0	—	—	—	—	V
ICCDR	Data Retention Current	MIL. COM'L.	—	0.5	1.5	200	300	μA
			—	0.5	1.5	20	30	
t <sub>CDR</sub> <sup>(3)</sup>	Chip Deselect to Data Retention Time	$\overline{CS} \geq V_{HC}$ V <sub>IN</sub> ≥ V <sub>HC</sub> or ≤ V <sub>LC</sub>	—	0	—	—	—	ns
t <sub>R</sub> <sup>(3)</sup>	Operation Recovery Time		t <sub>RC</sub> <sup>(2)</sup>	—	—	—	—	ns
I <sub>IL</sub>	Input Leakage Current		—	—	—	2	2	μA

3089 tbl 10

### NOTES:

- T<sub>A</sub> = + 25°C
- t<sub>RC</sub> = Read Cycle Time.
- This parameter is guaranteed by device characterization, but is not production tested.

### Low Vcc Data Retention Waveform

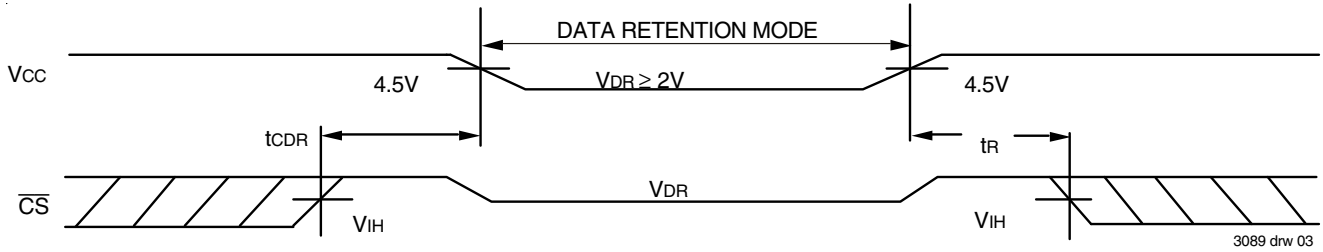

### AC Test Conditions

Input Pulse Levels	GND to 3.0V
Input Rise/Fall Times	5ns
Input Timing Reference Levels	1.5V
Output Reference Levels	1.5V
AC Test Load	See Figures 1 and 2

3089 tbl 11

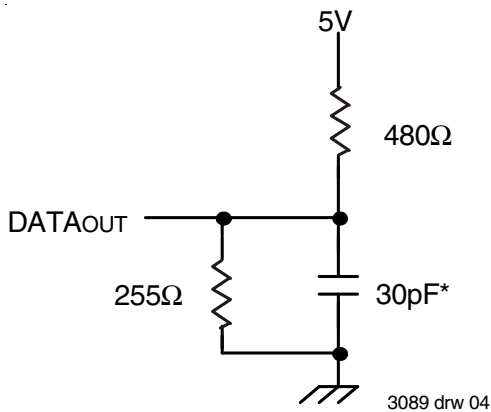

Figure 1. AC Test Load

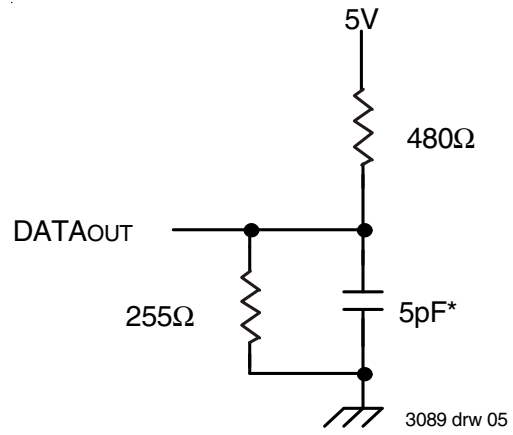

Figure 2. AC Test Load  
(for tOLZ, tCLZ, tOHZ, tWHZ, tCHZ & tOW)

\*Including scope and jig.

AC Electrical Characteristics (V<sub>CC</sub> = 5V ± 10%, All Temperature Ranges)

Symbol	Parameter	6116SA15 <sup>(1)</sup>		6116SA20 6116LA20		6116SA25 6116LA25		6116SA35 <sup>(2)</sup> 6116LA35 <sup>(2)</sup>		Unit
		Min.	Max.	Min.	Max.	Min.	Max.	Min.	Max.	
<b>Read Cycle</b>										
t <sub>RC</sub>	Read Cycle Time	15	—	20	—	25	—	35	—	ns
t <sub>AA</sub>	Address Access Time	—	15	—	19	—	25	—	35	ns
t <sub>ACS</sub>	Chip Select Access Time	—	15	—	20	—	25	—	35	ns
t <sub>CLZ</sub> <sup>(3)</sup>	Chip Select to Output in Low-Z	5	—	5	—	5	—	5	—	ns
t <sub>OE</sub>	Output Enable to Output Valid	—	10	—	10	—	13	—	20	ns
t <sub>OLZ</sub> <sup>(3)</sup>	Output Enable to Output in Low-Z	0	—	0	—	5	—	5	—	ns
t <sub>CHZ</sub> <sup>(3)</sup>	Chip Deselect to Output in High-Z	—	10	—	11	—	12	—	15	ns
t <sub>OHZ</sub> <sup>(3)</sup>	Output Disable to Output in High-Z	—	8	—	8	—	10	—	13	ns
t <sub>OH</sub>	Output Hold from Address Change	5	—	5	—	5	—	5	—	ns
t <sub>PU</sub> <sup>(3)</sup>	Chip Select to Power Up Time	0	—	0	—	0	—	0	—	ns
t <sub>PD</sub> <sup>(3)</sup>	Chip Deselect to Power Down Time	—	15	—	20	—	25	—	35	ns

3089 tbl 12

AC Electrical Characteristics (V<sub>CC</sub> = 5V ± 10%, All Temperature Ranges) (continued)

Symbol	Parameter	6116SA45 <sup>(2)</sup> 6116LA45 <sup>(2)</sup>		6116SA55 <sup>(2)</sup> 6116LA55 <sup>(2)</sup>		6116SA70 <sup>(2)</sup> 6116LA70 <sup>(2)</sup>		6116SA90 <sup>(2)</sup> 6116LA90 <sup>(2)</sup>		6116SA120 <sup>(2)</sup> 6116LA120 <sup>(2)</sup>		6116SA150 <sup>(2)</sup> 6116LA150 <sup>(2)</sup>		Unit
		Min.	Max.	Min.	Max.	Min.	Max.	Min.	Max.	Min.	Max.	Min.	Max.	
<b>Read Cycle</b>														
t <sub>RC</sub>	Read Cycle Time	45	—	55	—	70	—	90	—	120	—	150	—	ns
t <sub>AA</sub>	Address Access Time	—	45	—	55	—	70	—	90	—	120	—	150	ns
t <sub>ACS</sub>	Chip Select Access Time	—	45	—	50	—	65	—	90	—	120	—	150	ns
t <sub>CLZ</sub> <sup>(3)</sup>	Chip Select to Output in Low-Z	5	—	5	—	5	—	5	—	5	—	5	—	ns
t <sub>OE</sub>	Output Enable to Output Valid	—	25	—	40	—	50	—	60	—	80	—	100	ns
t <sub>OLZ</sub> <sup>(3)</sup>	Output Enable to Output in Low-Z	5	—	5	—	5	—	5	—	5	—	5	—	ns
t <sub>CHZ</sub> <sup>(3)</sup>	Chip Deselect to Output in High-Z	—	20	—	30	—	35	—	40	—	40	—	40	ns
t <sub>OHZ</sub> <sup>(3)</sup>	Output Disable to Output in High-Z	—	15	—	30	—	35	—	40	—	40	—	40	ns
t <sub>OH</sub>	Output Hold from Address Change	5	—	5	—	5	—	5	—	5	—	5	—	ns

3089 tbl 13

NOTES:

- 0°C to +70°C temperature range only.
- 55°C to +125°C temperature range only.
- This parameter guaranteed with the AC Load (Figure 2) by device characterization, but is not production tested.

### Timing Waveform of Read Cycle No. 1<sup>(1,3)</sup>

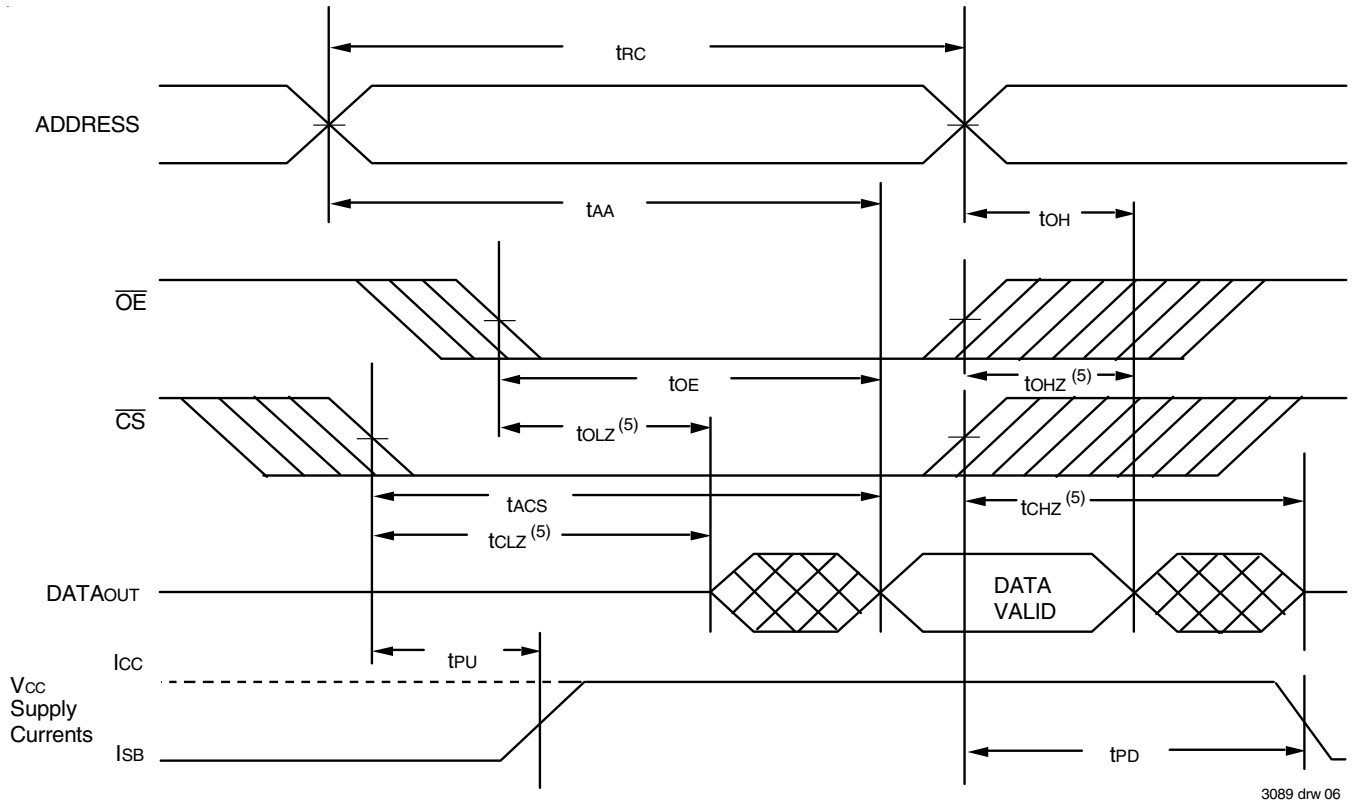

### Timing Waveform of Read Cycle No. 2<sup>(1,2,4)</sup>

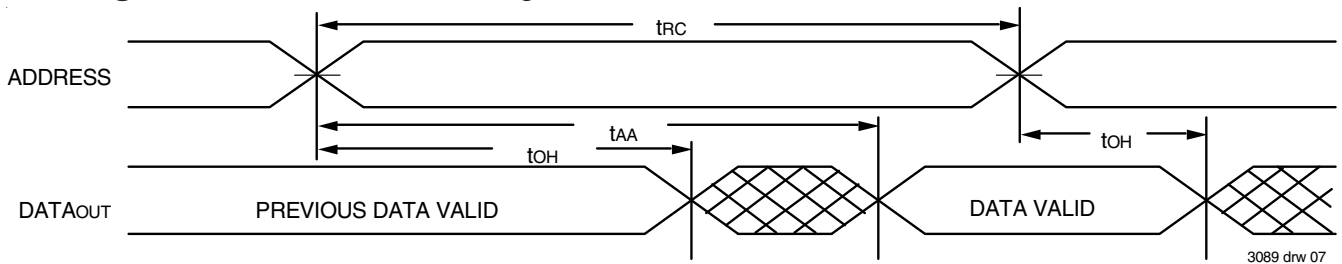

### Timing Waveform of Read Cycle No. 3<sup>(1,3,4)</sup>

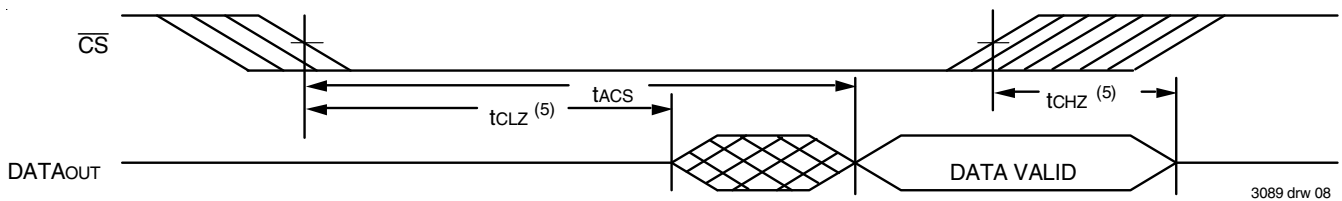

**NOTES:**

1.  $\overline{WE}$  is HIGH for Read cycle.
2. Device is continuously selected,  $\overline{CS}$  is LOW.
3. Address valid prior to or coincident with  $\overline{CS}$  transition LOW.
4.  $\overline{OE}$  is LOW.
5. Transition is measured  $\pm 500\text{mV}$  from steady state.

AC Electrical Characteristics ( $V_{CC} = 5V \pm 10\%$ , All Temperature Ranges)

Symbol	Parameter	6116SA15 <sup>(1)</sup>		6116SA20 6116LA20		6116SA25 6116LA25		6116SA35 <sup>(2)</sup> 6116LA35 <sup>(2)</sup>		Unit
		Min.	Max.	Min.	Max.	Min.	Max.	Min.	Max.	
<b>Write Cycle</b>										
t <sub>WC</sub>	Write Cycle Time	15	—	20	—	25	—	35	—	ns
t <sub>CW</sub>	Chip Select to End-of-Write	13	—	15	—	17	—	25	—	ns
t <sub>AW</sub>	Address Valid to End-of-Write	14	—	15	—	17	—	25	—	ns
t <sub>AS</sub>	Address Set-up Time	0	—	0	—	0	—	0	—	ns
t <sub>WP</sub>	Write Pulse Width	12	—	12	—	15	—	20	—	ns
t <sub>WR</sub>	Write Recovery Time	0	—	0	—	0	—	0	—	ns
t <sub>WHZ</sub> <sup>(3)</sup>	Write to Output in High-Z	—	7	—	8	—	16	—	20	ns
t <sub>DW</sub>	Data to Write Time Overlap	12	—	12	—	13	—	15	—	ns
t <sub>DH</sub> <sup>(4)</sup>	Data Hold from Write Time	0	—	0	—	0	—	0	—	ns
t <sub>OW</sub> <sup>(3,4)</sup>	Output Active from End-of-Write	0	—	0	—	0	—	0	—	ns

3089 tbl 14

AC Electrical Characteristics ( $V_{CC} = 5V \pm 10\%$ , All Temperature Ranges)(con't)

Symbol	Parameter	6116SA45 <sup>(2)</sup> 6116LA45 <sup>(2)</sup>		6116SA55 <sup>(2)</sup> 6116LA55 <sup>(2)</sup>		6116SA70 <sup>(2)</sup> 6116LA70 <sup>(2)</sup>		6116SA90 <sup>(2)</sup> 6116LA90 <sup>(2)</sup>		6116SA120 <sup>(2)</sup> 6116LA120 <sup>(2)</sup>		6116SA150 <sup>(2)</sup> 6116LA150 <sup>(2)</sup>		Unit
		Min.	Max.	Min.	Max.	Min.	Max.	Min.	Max.	Min.	Max.	Min.	Max.	
<b>Write Cycle</b>														
t <sub>WC</sub>	Write Cycle Time	45	—	55	—	70	—	90	—	120	—	150	—	ns
t <sub>CW</sub>	Chip Select to End-of-Write	30	—	40	—	40	—	55	—	70	—	90	—	ns
t <sub>AW</sub>	Address Valid to End-of-Write	30	—	45	—	65	—	80	—	105	—	120	—	ns
t <sub>AS</sub>	Address Set-up Time	0	—	5	—	15	—	15	—	20	—	20	—	ns
t <sub>WP</sub>	Write Pulse Width	25	—	40	—	40	—	55	—	70	—	90	—	ns
t <sub>WR</sub>	Write Recovery Time	0	—	5	—	5	—	5	—	5	—	10	—	ns
t <sub>WHZ</sub> <sup>(3)</sup>	Write to Output in High-Z	—	25	—	30	—	35	—	40	—	40	—	40	ns
t <sub>DW</sub>	Data to Write Time Overlap	20	—	25	—	30	—	30	—	35	—	40	—	ns
t <sub>DH</sub> <sup>(4)</sup>	Data Hold from Write Time	0	—	5	—	5	—	5	—	5	—	10	—	ns
t <sub>OW</sub> <sup>(3,4)</sup>	Output Active from End-of-Write	0	—	0	—	0	—	0	—	0	—	0	—	ns

3089 tbl 15

NOTES:

- 0°C to +70°C temperature range only.
- 55°C to +125°C temperature range only.
- This parameter guaranteed with AC Load (Figure 2) by device characterization, but is not production tested.
- The specification for t<sub>DH</sub> must be met by the device supplying write data to the RAM under all operation conditions. Although t<sub>DH</sub> and t<sub>OW</sub> values will vary over voltage and temperature, the actual t<sub>DH</sub> will always be smaller than the actual t<sub>OW</sub>.

### Timing Waveform of Write Cycle No. 1 ( $\overline{WE}$ Controlled Timing)<sup>(1,2,5,7)</sup>

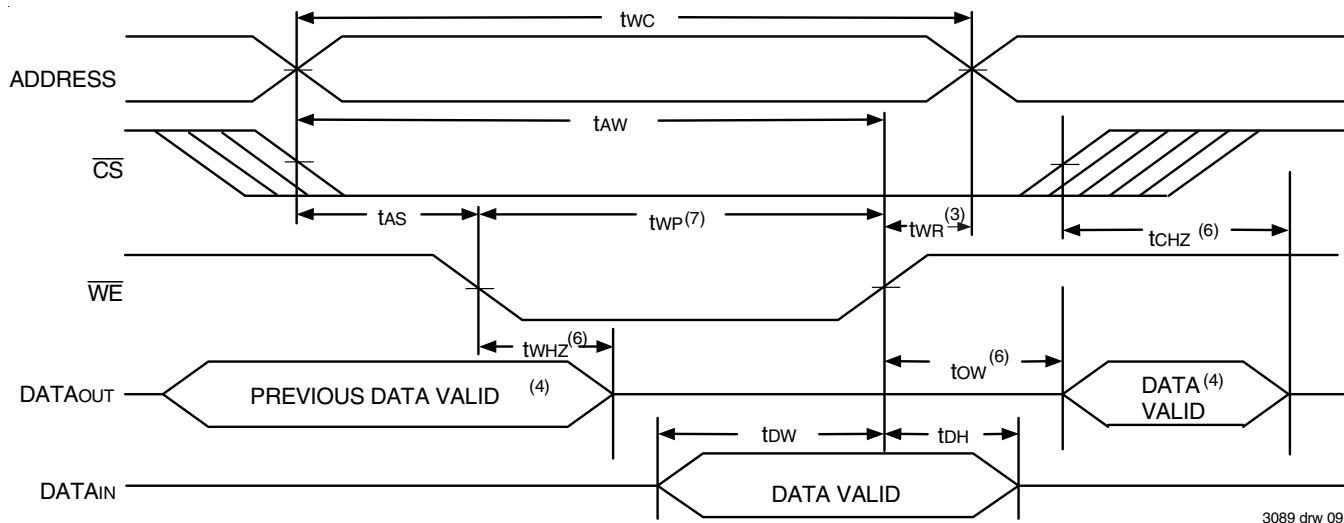

3089 drw 09

### Timing Waveform of Write Cycle No. 2 ( $\overline{CS}$ Controlled Timing)<sup>(1,2,3,5,7)</sup>

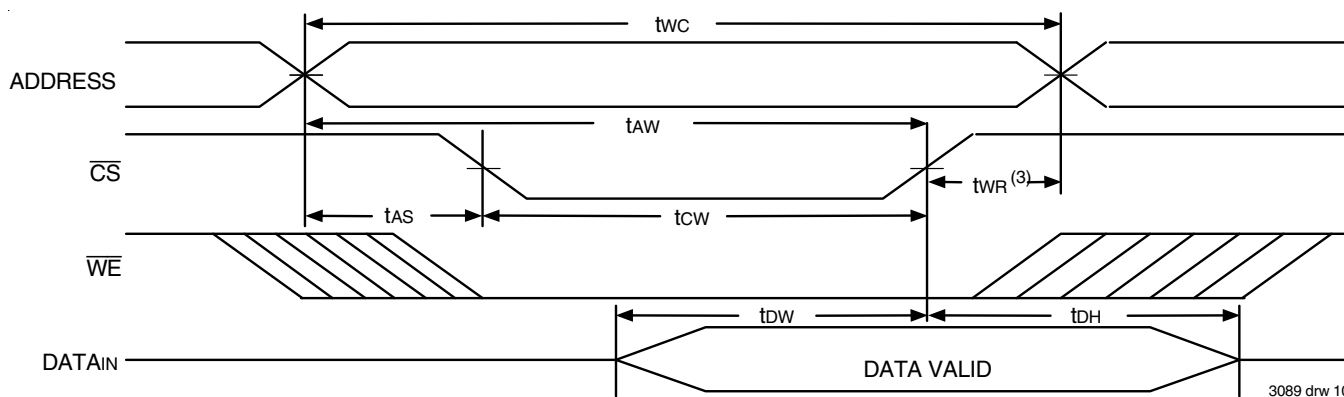

3089 drw 10

**NOTES:**

1.  $\overline{WE}$  or  $\overline{CS}$  must be HIGH during all address transitions.
2. A write occurs during the overlap of a LOW  $\overline{CS}$  and a LOW  $\overline{WE}$ .
3.  $t_{WR}$  is measured from the earlier of  $\overline{CS}$  or  $\overline{WE}$  going HIGH to the end of the write cycle.
4. During this period, the I/O pins are in the output state and the input signals must not be applied.
5. If the  $\overline{CS}$  LOW transition occurs simultaneously with or after the  $\overline{WE}$  LOW transition, the outputs remain in the high-impedance state.
6. Transition is measured  $\pm 500\text{mV}$  from steady state.
7.  $\overline{OE}$  is continuously HIGH. If  $\overline{OE}$  is LOW during a  $\overline{WE}$  controlled write cycle, the write pulse width must be the larger of  $t_{WP}$  or  $(t_{WHZ} + t_{DW})$  to allow the I/O drivers to turn off and data to be placed on the bus for the required  $t_{DW}$ . If  $\overline{OE}$  is HIGH during a  $\overline{WE}$  controlled write cycle, this requirement does not apply and the write pulse is the specified  $t_{WP}$ . For a  $\overline{CS}$  controlled write cycle,  $\overline{OE}$  may be LOW with no degradation to  $t_{CW}$ .

## Ordering Information — Military

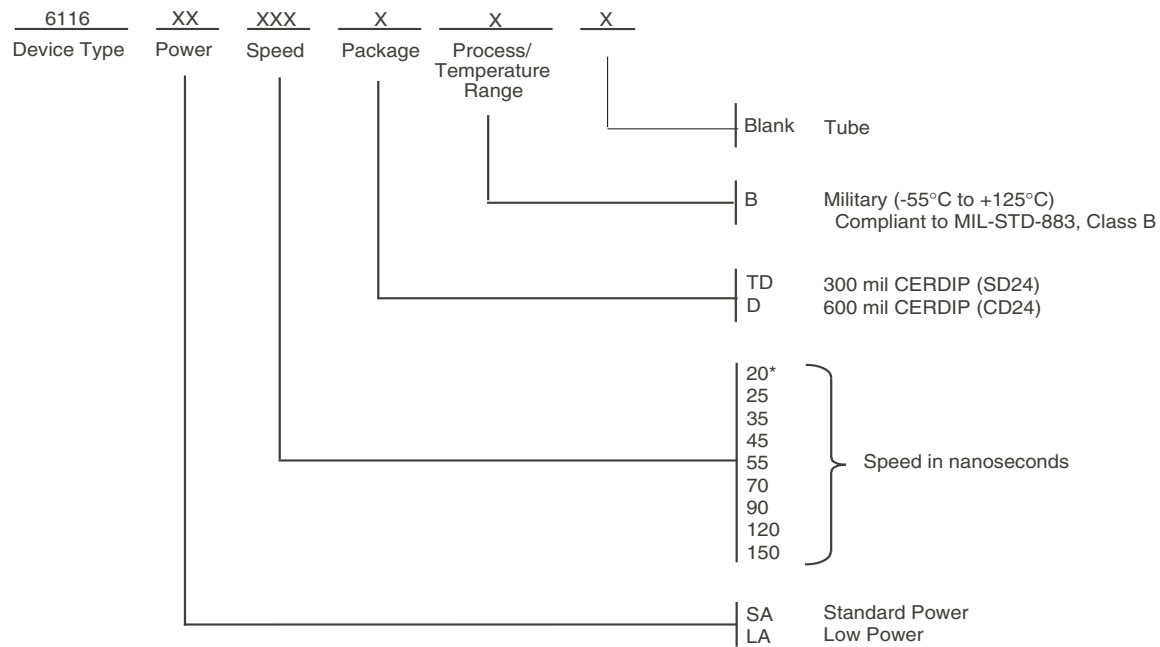

3089 drw 11

## Ordering Information — Commercial & Industrial

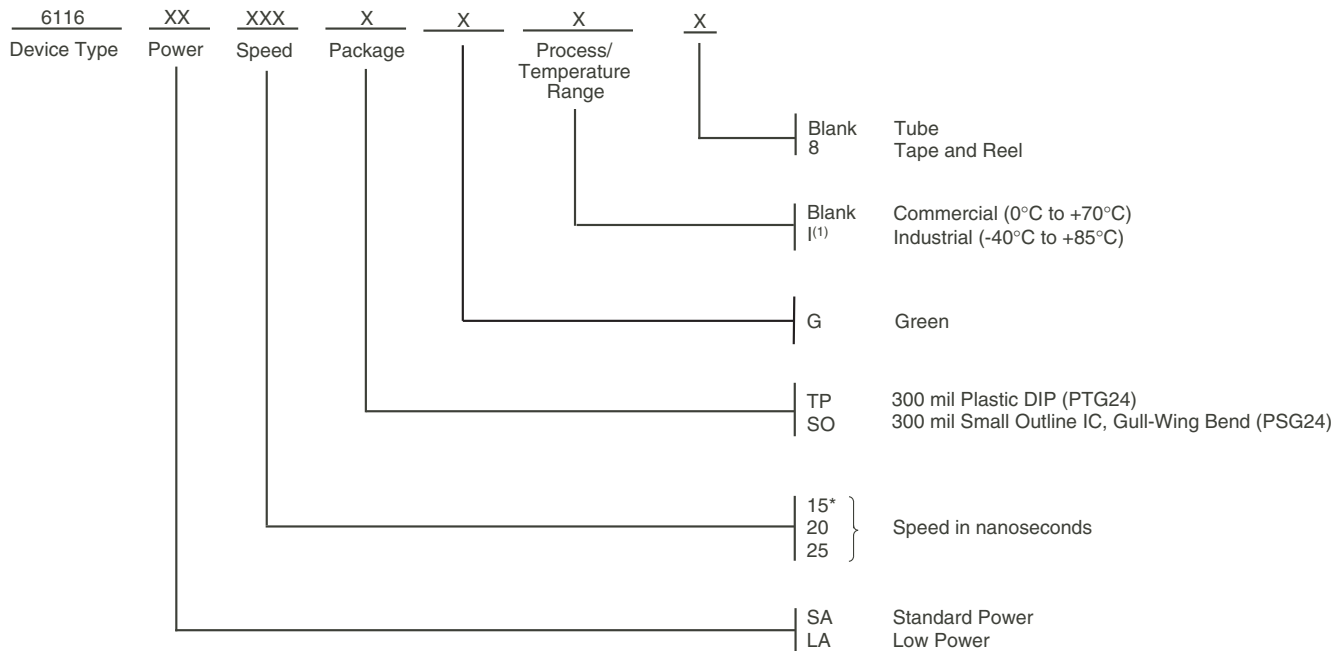

\*Available in commercial temperature range and standard power only.

**NOTE:**

1. Contact your local sales office for industrial temp range for other speeds, packages and powers.

3089 drw 12

### Orderable Part Information

Speed (ns)	Orderable Part ID	Pkg. Code	Pkg. Type	Temp. Grade
20	6116LA20SOG	PSG24	SOIC	C
	6116LA20SOG8	PSG24	SOIC	C
	6116LA20SOGI	PSG24	SOIC	I
	6116LA20SOG8	PSG24	SOIC	I
	6116LA20TDB	SD24	CDIP	M
	6116LA20TPG	PTG24	PDIP	C
	6116LA20TPGI	PTG24	PDIP	I
25	6116LA25DB	CD24	CDIP	M
	6116LA25SOG	PSG24	SOIC	C
	6116LA25SOG8	PSG24	SOIC	C
	6116LA25SOGI	PSG24	SOIC	I
	6116LA25SOG8	PSG24	SOIC	I
	6116LA25TDB	SD24	CDIP	M
	6116LA25TPG	PTG24	PDIP	C
35	6116LA35DB	CD24	CDIP	M
	6116LA35TDB	SD24	CDIP	M
45	6116LA45DB	CD24	CDIP	M
	6116LA45TDB	SD24	CDIP	M
55	6116LA55DB	CD24	CDIP	M
	6116LA55TDB	SD24	CDIP	M
70	6116LA70DB	CD24	CDIP	M
	6116LA70TDB	SD24	CDIP	M
90	6116LA90DB	CD24	CDIP	M
	6116LA90TDB	SD24	CDIP	M
120	6116LA120DB	CD24	CDIP	M
	6116LA120TDB	SD24	CDIP	M
150	6116LA150DB	CD24	CDIP	M
	6116LA150TDB	SD24	CDIP	M

Speed (ns)	Orderable Part ID	Pkg. Code	Pkg. Type	Temp. Grade
15	6116SA15SOG	PSG24	SOIC	C
	6116SA15SOG8	PSG24	SOIC	C
	6116SA15TPG	PTG24	PDIP	C
20	6116SA20DB	CD24	CDIP	M
	6116SA20SOG	PSG24	SOIC	C
	6116SA20SOG8	PSG24	SOIC	C
	6116SA20TDB	SD24	CDIP	M
	6116SA20TPG	PTG24	PDIP	C
	6116SA20TPGI	PTG24	PDIP	I
25	6116SA25SOG	PSG24	SOIC	C
	6116SA25SOG8	PSG24	SOIC	C
	6116SA25SOGI	PSG24	SOIC	I
	6116SA25SOG8	PSG24	SOIC	I
	6116SA25TDB	SD24	CDIP	M
	6116SA25TPG	PTG24	PDIP	C
	6116SA25TPGI	PTG24	PDIP	I
	6116SA25TPGI	PTG24	PDIP	I
35	6116SA35TDB	SD24	CDIP	M
45	6116SA45DB	CD24	CDIP	M
	6116SA45TDB	SD24	CDIP	M
55	6116SA55DB	CD24	CDIP	M
	6116SA55TDB	SD24	CDIP	M
70	6116SA70DB	CD24	CDIP	M
	6116SA70TDB	SD24	CDIP	M
90	6116SA90DB	CD24	CDIP	M
	6116SA90TDB	SD24	CDIP	M
120	6116SA120DB	CD24	CDIP	M
	6116SA120TDB	SD24	CDIP	M
150	6116SA150DB	CD24	CDIP	M
	6116SA150TDB	SD24	CDIP	M

## Datasheet Document History

01/07/00		Updated to new format
	Pg. 1, 3, 4, 10	Added Industrial Temperature range offerings
	Pg. 9, 10	Separated ordering information into military, commercial, and industrial temperature range offerings
	Pg. 11	Added Datasheet Document History
08/09/00		Not recommended for new designs
02/01/01		Removed "Not recommended for new designs"
12/30/03	Pg. 3,10	Corrected Industrial temp from -45C to -40C.
03/31/05	Pg. 10	Added "Restricted hazardous substance device" to ordering information.
11/15/06	Pg. 3	Changed power limits for commercial and industrial on speed grades 25ns and 35ns.
	Pg.4	Changed power limits for commercial and industrial on speed grade 45ns. Refer to PCN SR-0602-02.
04/26/11	Pg.1,2,3,4,6,10	Updated "Restricted hazardous substance device" to "Green". Obsoleted 24-pin SOJ, 24-pin 600 mil and 35ns, 45ns for Industrial & Commercial.
05/01/13	Pg. 1	Description paragraph 4, package information. Changed text to read "The IDT6116SA/LA is packaged in 24-pin 300mil plastic DIP, 24-pin 600mil and 300mil ceramic DIP, or 24-lead gull-wing SOIC providing high board-level packing densities". Removed IDT in reference to fabrication.
	Pg. 3	Updated DC Elec Chars ( $V_{CC} = 5.0V \pm 10\%$ ) table by adding industrial to the Test Conditions. Updated DC Elec Chars ( $V_{CC} = 5.0V \pm 10\%$ , $V_{LC} = 0.2V$ , $V_{HC} + V_{CC} - 0.2V$ ) table by removing the LA power for the 15ns speed.
	Pg. 10	Removed footnote "**Available in 300mil packaging only" from the Military ordering information.
07/17/20	Pg. 1 - 13	Rebranded as Renesas datasheet
	Pg. 2 & 10	Updated package codes.
	Pg. 10	Updated Ordering Information.
	Pg. 11	Added Orderable Part Information tables.

## IMPORTANT NOTICE AND DISCLAIMER

RENESAS ELECTRONICS CORPORATION AND ITS SUBSIDIARIES (“RENESAS”) PROVIDES TECHNICAL SPECIFICATIONS AND RELIABILITY DATA (INCLUDING DATASHEETS), DESIGN RESOURCES (INCLUDING REFERENCE DESIGNS), APPLICATION OR OTHER DESIGN ADVICE, WEB TOOLS, SAFETY INFORMATION, AND OTHER RESOURCES “AS IS” AND WITH ALL FAULTS, AND DISCLAIMS ALL WARRANTIES, EXPRESS OR IMPLIED, INCLUDING, WITHOUT LIMITATION, ANY IMPLIED WARRANTIES OF MERCHANTABILITY, FITNESS FOR A PARTICULAR PURPOSE, OR NON-INFRINGEMENT OF THIRD-PARTY INTELLECTUAL PROPERTY RIGHTS.

These resources are intended for developers who are designing with Renesas products. You are solely responsible for (1) selecting the appropriate products for your application, (2) designing, validating, and testing your application, and (3) ensuring your application meets applicable standards, and any other safety, security, or other requirements. These resources are subject to change without notice. Renesas grants you permission to use these resources only to develop an application that uses Renesas products. Other reproduction or use of these resources is strictly prohibited. No license is granted to any other Renesas intellectual property or to any third-party intellectual property. Renesas disclaims responsibility for, and you will fully indemnify Renesas and its representatives against, any claims, damages, costs, losses, or liabilities arising from your use of these resources. Renesas' products are provided only subject to Renesas' Terms and Conditions of Sale or other applicable terms agreed to in writing. No use of any Renesas resources expands or otherwise alters any applicable warranties or warranty disclaimers for these products.

(Disclaimer Rev.1.01 Jan 2024)

### Corporate Headquarters

TOYOSU FORESIA, 3-2-24 Toyosu,  
Koto-ku, Tokyo 135-0061, Japan  
[www.renesas.com](http://www.renesas.com)

### Trademarks

Renesas and the Renesas logo are trademarks of Renesas Electronics Corporation. All trademarks and registered trademarks are the property of their respective owners.

### Contact Information

For further information on a product, technology, the most up-to-date version of a document, or your nearest sales office, please visit [www.renesas.com/contact-us/](http://www.renesas.com/contact-us/).

## Looking for pricing, stock, or lifecycle information?

Click below to explore more details on WIN SOURCE:

-  [View 6116LA90TDB on WIN SOURCE](#)
-  [Renesas Electronics America](#) Information

## Optimize Your Supply Chain with WIN SOURCE Solutions

-  Global Sourcing Solution
-  Obsolete Management
-  Cost Control Management
-  Shortage Management
-  Alternative Solution
-  Excess Inventory Management