



**THE DATASHEET OF  
BD6718FV-E2**



### DC Brushless Motor Drivers for Cooling Fans

# Speed Controllable Single-phase Full-wave DC Brushless Fan Motor Drivers BD6709FS, BD6718FV, BD6721FS, BD6722FS



#### ●Description

This is the summary of models that suit for 12V speed controllable fan for desktop PC and general consumer equipment. They employ Bi-CDMOS process, and realize low ON resistance, low power consumption. They incorporate lock protection and automatic restart circuit, current limiting circuit.

#### ●Features

- 1) Power Tr incorporated (BD6709FS, BD6721FS)
- 2) Pre-driver compatible for external Tr (BD6718FV)
- 3) Low side power Tr incorporated half pre-driver (BD6722FS)
- 4) Current limiting circuit
- 5) PWM soft switching driver (BD6721FS, BD6722FS)
- 6) Soft start circuit (BD6722FS)
- 7) Lock protection and automatic restart circuit
- 8) Rotating speed pulse signal (FG) output
- 9) Lock alarm signal (AL) output (BD6718FV, BD6721FS, BD6722FS)

#### ● Application

For 12V fan for desktop PC, server and general consumer equipment

#### ●Lineup

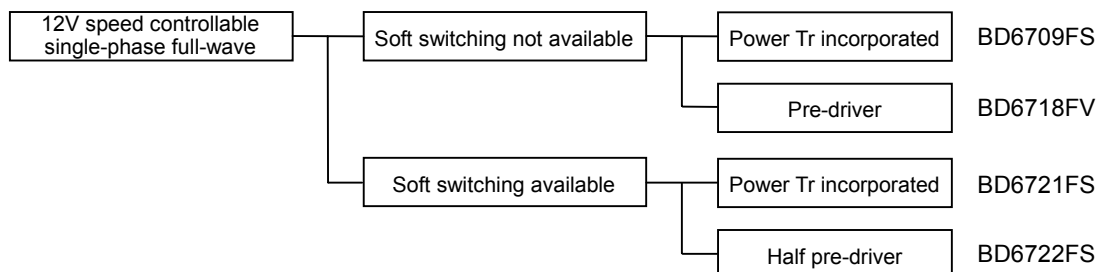

●Absolute Maximum Ratings

◎BD6709FS

Parameter	Symbol	Limit	Unit
Supply voltage	Vcc	17	V
Power dissipation	Pd	812.5 *	mW
Operation temperature	Topr	-40~+95	°C
Storage temperature	Tstg	-55~+150	°C
Output current	Iomax	1.2 * *	A
FG signal output current	IFG	10	mA
FG signal output voltage	VFG	15	V
Junction temperature	Tjmax	150	°C

\* Reduce by 6.5mW/°C over 25°C.  
(On 70.0mm×70.0mm×1.6mm glass epoxy board)

\* \* This value is not to exceed Pd.

◎BD6718FV

Parameter	Symbol	Limit	Unit
Supply voltage	Vcc	15	V
Power dissipation	Pd	812.5 *	mW
Operation temperature	Topr	-40~+95	°C
Storage temperature	Tstg	-55~+150	°C
High side output voltage	VOH	36	V
Low side output voltage	VOL	15	V
Low side output current	Iomax	20	mA
FG signal output current	IFG	8	mA
FG signal output voltage	VFG	15	V
AL signal output current	IAL	8	mA
AL signal output voltage	VAL	15	V
VREF current ability	IVREF	4	mA
HB current ability	IHB	8	mA
Junction temperature	Tjmax	150	°C

\* Reduce by 6.5mW/°C over 25°C.  
(On 70.0mm×70.0mm×1.6mm glass epoxy board)

◎BD6721FS

Parameter	Symbol	Limit	Unit
Supply voltage	Vcc	20	V
Power dissipation	Pd	812.5 *	mW
Operation temperature	Topr	-40~+100	°C
Storage temperature	Tstg	-55~+150	°C
Output current	Iomax	1.0 * *	A
FG signal output current	IFG	10	mA
FG signal output voltage	VFG	20	V
AL signal output current	IAL	10	mA
AL signal output voltage	VAL	20	V
VREF current ability	IVREF	8	mA
Junction temperature	Tjmax	150	°C

\* Reduce by 6.5mW/°C over 25°C.  
(On 70.0mm×70.0mm×1.6mm glass epoxy board)

\* \* This value is not to exceed Pd.

◎BD6722FS

Parameter	Symbol	Limit	Unit
Supply voltage	Vcc	20	V
Power dissipation	Pd	812.5 *	mW
Operation temperature	Topr	-40~+100	°C
Storage temperature	Tstg	-55~+150	°C
High side output voltage	VOH	34	V
Low side output voltage	VOL	34	V
Low side output current	Iomax	1.5 * *	A
Signal output current	IFG/IAL	10	mA
Signal output voltage	VFG/VAL	20	V
VREF current ability	IVREF	8	mA
VTH input voltage	VVTH	15	V
Junction temperature	Tjmax	150	°C

\* Reduce by 6.5mW/°C over 25°C.  
(On 70.0mm×70.0mm×1.6mm glass epoxy board)

\* \* This value is not to exceed Pd.

●OPERATING CONDITIONS

◎BD6709FS

Parameter	Symbol	Limit	Unit
Operating supply voltage range	Vcc	6.0~14.0	V
Hall input voltage range	VH	0.5~Vcc-1.5	V

◎BD6718FV

Parameter	Symbol	Limit	Unit
Operating supply voltage range	Vcc	4.5~14.0	V
Hall input voltage range	VH	0~Vcc-2.0	V

◎BD6721FS

Parameter	Symbol	Limit	Unit
Operating supply voltage range	Vcc	5.0~17.0	V
Hall input voltage range	VH	0~Vcc-2.0	V
VTH input voltage range	VVTH	0~Vcc-2.0	V
VMIN input voltage range	VVMIN	0~Vcc-2.0	V

◎BD6722FS

Parameter	Symbol	Limit	Unit
Operating supply voltage range	Vcc	5.0~17.0	V
Hall input voltage range	VH	0~Vcc-2.0	V
VMIN input voltage range	VVMIN	0~Vcc-2.0	V

● ELECTRICAL CHARACTERISTICS (Unless otherwise specified Ta=25°C, Vcc=12V)

◎BD6709FS

Parameter	Symbol	Limit			Unit	Conditions	Characteristics
		Min.	Typ.	Max.			
Circuit current	Icc	3.0	6.0	9.0	mA		Fig.1
Hall input hysteresis	VHYS	±5	±10	±15	mV		Fig.2
Output low voltage	VOL	-	0.2	0.3	V	Io=200mA	Fig.3,4
Output high voltage	VOH	-	0.2	0.3	V	Io=-200mA Voltage between output and Vcc	Fig.5,6
Lock detection ON time	TON	0.30	0.50	0.70	sec		Fig.7
Lock detection OFF time	TOFF	2.5	4.0	5.5	sec		Fig.8
FG output low voltage	VFGL	-	-	0.3	V	IFG=5mA	Fig.9,10
FG output leak current	IFGL	-	-	50	μA	VFG=15V	-
OSC low voltage	VOSCL	1.5	2.0	2.5	V		Fig.11
OSC high voltage	VOSCH	3.0	3.5	4.0	V		Fig.12
OSC frequency	FOSC	-	25 *	-	kHz	COSC=470pF	-
Level amp gain	GLA	50	-	-	dB		-
Level amp output low voltage	VLAOL	-	0.9	1.2	V	ILAOUT=1mA	-
Level amp output high voltage	VLAOH	-	1.2	1.5	V	ILAOUT=-1mA Voltage between output and Vcc	-
VREF voltage	VREF	4.0	4.4	4.8	V	IVREF=-1mA	Fig.14,15
CL-CS offset voltage	Vcofs	-	-	30	mV		

\* This voltage is reference, not guarantee.

◎BD6718FV

Parameter	Symbol	Limit			Unit	Conditions	Characteristics
		Min.	Typ.	Max.			
Circuit current	Icc	4.0	8.0	12.0	mA		Fig.16
Hall input hysteresis	VHYS	±5	±10	±15	mV		Fig.17
H side output current	IH	5	10	20	mA		Fig.18
H side output leak current	IHL	-	-	100	μA		-
L side output high voltage	VLH	-	0.2	0.35	V	Io=-10mA Voltage between output and Vcc	Fig.19
L side output low voltage	VLL	-	0.2	0.35	V	Io=10mA	Fig.20
Lock detection ON time1	TON1	0.15	0.3	0.5	sec	SEL(6PIN) : OPEN or H	Fig.21
Lock detection OFF time1	TOFF1	1.5	3.0	5.0	sec	SEL(6PIN) : OPEN or H	Fig.22
Lock detection ON time2	TON2	0.15	0.3	0.5	sec	SEL(6PIN)=L	Fig.21
Lock detection OFF time2	TOFF2	3.0	6.0	10	sec	SEL(6PIN)=L	Fig.23
FG output low voltage	VFGL	-	0.3	0.4	V	IFG=5mA	Fig.24
AL output low voltage	VALL	-	0.3	0.4	V	IAL=5mA	Fig.24
FG output leak current	IFGL	-	-	50	μA	VFG=15V	-
AL output leak current	IALL	-	-	50	μA	VAL=15V	-
OSC low voltage	VOSCL	0.4	0.7	1.0	V		Fig.25
OSC high voltage	VOSCH	1.2	1.5	1.8	V		Fig.26
OSC frequency	FOSC	-	25 *	-	kHz	COSC=470pF	-
VREF voltage	VREF	2.2	2.5	2.8	V	IVREF=-1mA	Fig.27
Hall bias voltage	VHB	1.2	1.5	1.8	V		Fig.28
CR current ability	ICR	3	-	-	mA	VCR=1.5V	-
CR output low voltage	VCR	-	0.3	0.5	V	ICR=0.5mA	Fig.29
CR discharge time	TCR	9	18.5	28	μsec		Fig.30

\* This voltage is reference, not guarantee.

Parameter	Symbol	Limit			Unit	Conditions	Characteristics
		Min.	Typ.	Max.			
Circuit current	I <sub>CC</sub>	4.0	7.0	10.0	mA		Fig.31
Hall input hysteresis	V <sub>HYS</sub>	±5	±10	±15	mV		Fig.32
Output voltage	V <sub>O</sub>	-	0.6	0.9	V	I <sub>o</sub> =300mA Upper and Lower total	Fig.33~36
Lock detection ON time	T <sub>ON</sub>	0.30	0.50	0.70	sec		Fig.37
Lock detection OFF time	T <sub>OFF</sub>	3.0	5.0	7.0	sec		Fig.38
FG output low voltage	V <sub>FGL</sub>	-	0.15	0.3	V	I <sub>FG</sub> =5mA	Fig.39,40
FG output leak current	I <sub>FGL</sub>	-	-	50	μA	V <sub>FG</sub> =17V	Fig.41
AL output low voltage	V <sub>ALL</sub>	-	0.15	0.3	V	I <sub>AL</sub> =5mA	Fig.39,40
AL output leak current	I <sub>ALL</sub>	-	-	50	μA	V <sub>AL</sub> =17V	Fig.41
OSC low voltage	V <sub>OSCL</sub>	0.8	1.0	1.2	V		Fig.42
OSC high voltage	V <sub>OSCH</sub>	2.3	2.5	2.7	V		Fig.43
OSC charge current	I <sub>COSC</sub>	-50	-32	-26	μA		Fig.44
OSC discharge current	I <sub>DOSC</sub>	26	32	50	μA		Fig.44
Level amp gain	G <sub>LA</sub>	50	-	-	dB		-
Level amp output low voltage	V <sub>LAOL</sub>	-	0.2	0.3	V		-
Level amp output high voltage	V <sub>LAOH</sub>	-	1.6	2.0	V	Voltage between LAOUT and V <sub>CC</sub>	-
Output ON Duty 1	D <sub>UTY1</sub>	85	90	95	%	V <sub>TH</sub> =V <sub>REF</sub> *0.383 OUT1=Pull up 1kΩ COSC=470pF	-
Output ON Duty 2	D <sub>UTY2</sub>	45	50	55	%	V <sub>TH</sub> =V <sub>REF</sub> *0.583 OUT1=Pull up 1kΩ COSC=470pF	-
Output ON Duty 3	D <sub>UTY3</sub>	5	10	15	%	V <sub>TH</sub> =V <sub>REF</sub> *0.783 OUT1=Pull up 1kΩ COSC=470pF	-
V <sub>REF</sub> voltage	V <sub>REF</sub>	2.8	3.0	3.2	V	I <sub>VREF</sub> =-2mA	Fig.45
Current limit voltage	V <sub>CL</sub>	290	310	330	mV		Fig.46
V <sub>TH</sub> input bias current	I <sub>VTH</sub>	-	-	0.2	μA		Fig.47
V <sub>MIN</sub> input bias current	I <sub>VMIN</sub>	-	-	0.2	μA		Fig.48

◎BD6722FS

Parameter	Symbol	Limit			Unit	Conditions	Characteristics
		Min.	Typ.	Max.			
Circuit current	I <sub>CC</sub>	5.0	8.0	11.0	mA		Fig.52
Hall input hysteresis	V <sub>HYS</sub>	±5	±10	±15	mV		Fig.53
High side output current	I <sub>H</sub>	5	10	20	mA		Fig.54
High side output leak current	I <sub>HL</sub>	-	-	10	μA	V <sub>H</sub> =34V	Fig.55
Low side output voltage	V <sub>L</sub>	-	0.3	0.45	V	I <sub>o</sub> =600mA	Fig.56,57
Lock detection ON time	T <sub>ON</sub>	0.18	0.3	0.42	sec		Fig.58
Lock detection OFF time	T <sub>OFF</sub>	3.6	6.0	8.4	sec		Fig.59
FG output low voltage	V <sub>FGL</sub>	-	0.15	0.3	V	I <sub>FG</sub> =5mA	Fig.61,62
FG output leak current	I <sub>FGL</sub>	-	-	10	μA	V <sub>FG</sub> =17V	Fig.60
AL output low voltage	V <sub>ALL</sub>	-	0.15	0.3	V	I <sub>AL</sub> =5mA	Fig. 61,62
AL output leak current	I <sub>ALL</sub>	-	-	10	μA	V <sub>AL</sub> =17V	Fig.60
OSC low voltage	V <sub>OSCL</sub>	0.8	1.0	1.2	V		Fig.63
OSC high voltage	V <sub>OSCH</sub>	2.24	2.44	2.64	V		Fig.64
OSC charge current	I <sub>COSEC</sub>	-50	-32	-26	μA		Fig.65
OSC discharge current	I <sub>DOSC</sub>	26	32	50	μA		Fig.65
Output ON Duty 1	DUTY1	75	80	85	%	V <sub>TH</sub> =V <sub>REF</sub> *0.429 A1H=Pull up 1kΩ COSC=470pF	-
Output ON Duty 2	DUTY2	45	50	55	%	V <sub>TH</sub> =V <sub>REF</sub> *0.573 A1H=Pull up 1kΩ COSC=470pF	-
Output ON Duty 3	DUTY3	15	20	25	%	V <sub>TH</sub> =V <sub>REF</sub> *0.717 A1H=Pull up 1kΩ COSC=470pF	-
V <sub>REF</sub> voltage	V <sub>REF</sub>	2.8	3.0	3.2	V	I <sub>VREF</sub> =-2mA	Fig.66,67
Current limit voltage	V <sub>CL</sub>	320	350	380	mV		Fig.68
V <sub>TH</sub> input bias current	I <sub>VTH</sub>	-	-	0.2	μA		Fig.69
V <sub>MIN</sub> input bias current	I <sub>VMIN</sub>	-	-	0.2	μA		Fig.70

● Truth table

◎BD6709FS

H+	H-	OUT1	OUT2	FG
H	L	L	H	H
L	H	H	L	L

◎BD6718FV

H+	H-	CR	A1H	A1L	A2H	A2L	FG
H	L	H	Hi-Z	H	L	L	H
L	H	H	L	L	Hi-Z	H	L

◎BD6721FS

H+	H-	OUT1	OUT2	FG
H	L	L	H	H
L	H	H	L	L

◎BD6718FV

H+	H-	A1H	A1L	A2H	A2L	FG
H	L	Hi-Z	L	L	Hi-Z	H
L	H	L	Hi-Z	Hi-Z	L	L

◎BD6709FS

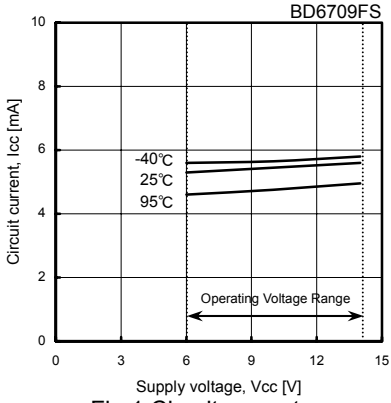

Fig.1 Circuit current

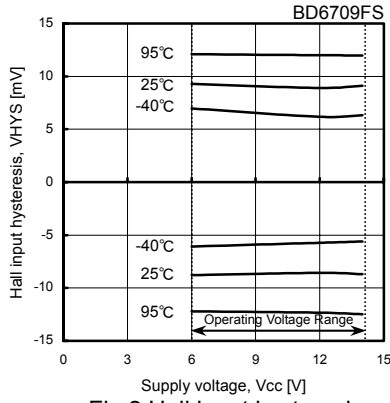

Fig.2 Hall input hysteresis

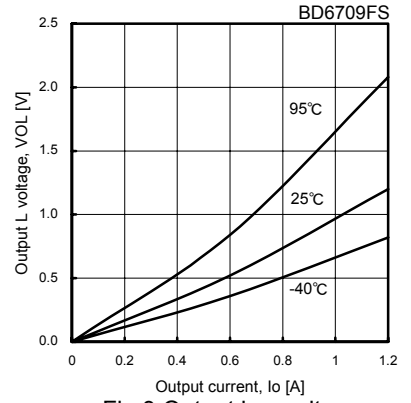

Fig.3 Output low voltage (Temperature characteristics)

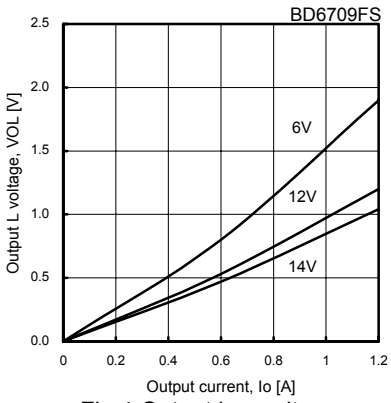

Fig.4 Output low voltage (Voltage characteristics)

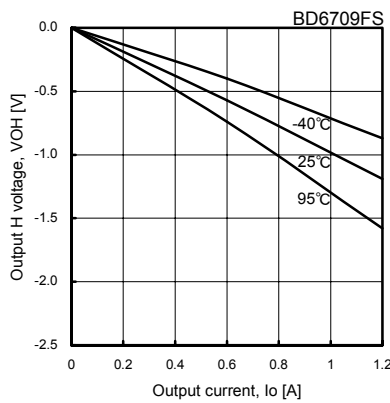

Fig.5 Output high voltage (Temperature characteristics)

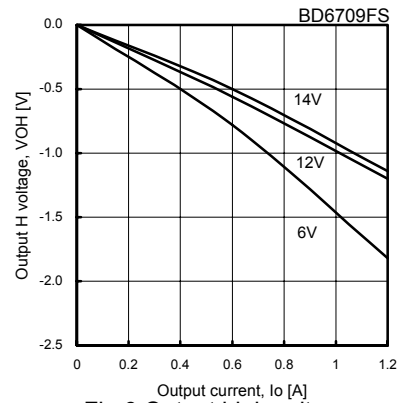

Fig.6 Output high voltage (Voltage characteristics)

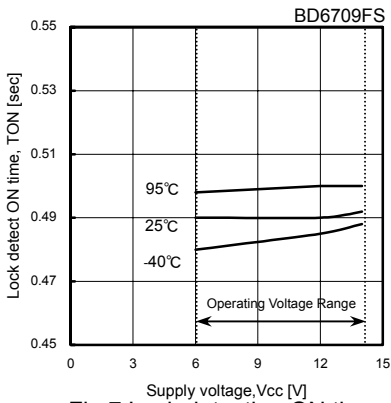

Fig.7 Lock detection ON time

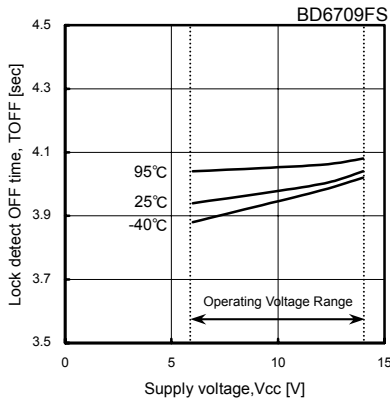

Fig.8 Lock detection OFF time

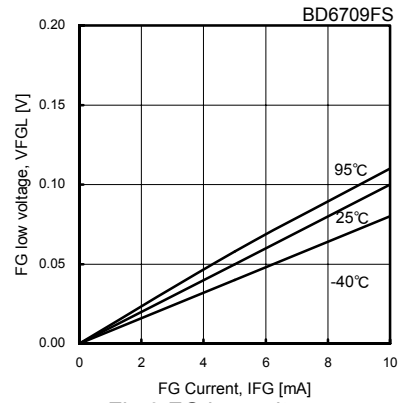

Fig.9 FG low voltage (Temperature characteristics)

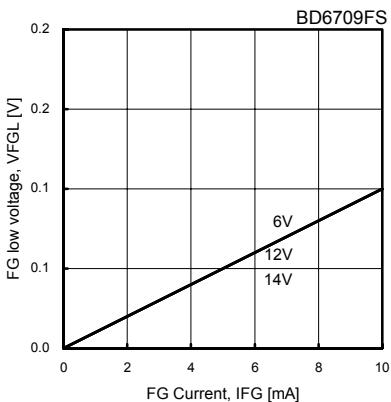

Fig.10 FG low voltage (Voltage characteristics)

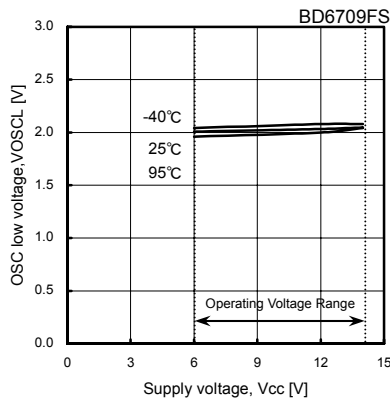

Fig.11 OSC low voltage

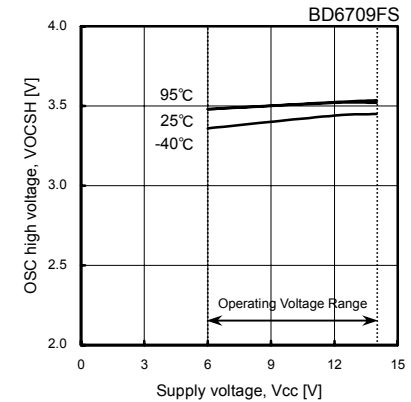

Fig.12 OSC high voltage

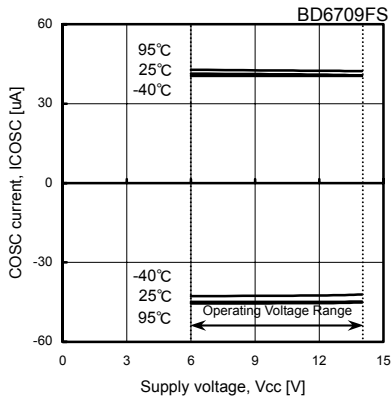

Fig.13 COSC charge discharge current

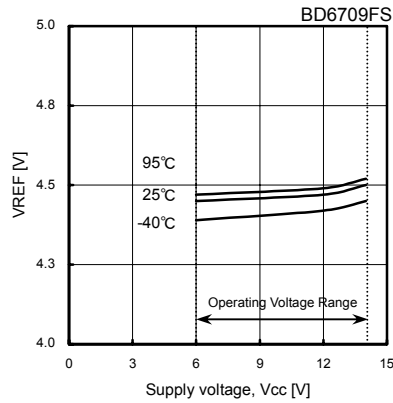

Fig.14 VREF voltage

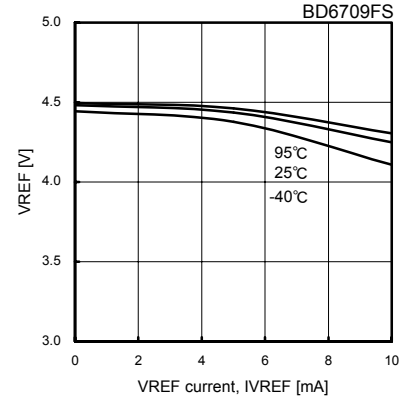

Fig.15 VREF current ability

©BD6718FV

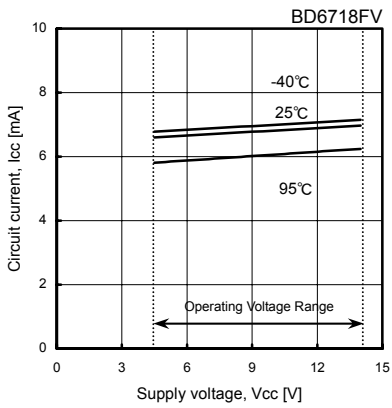

Fig.16 Circuit current

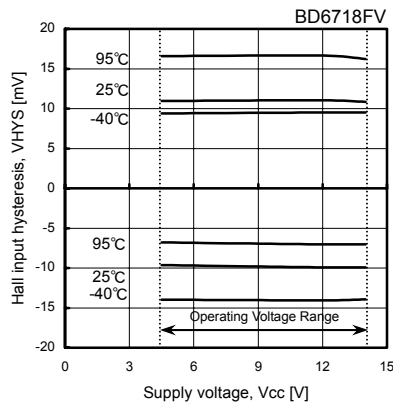

Fig.17 Hall input hysteresis

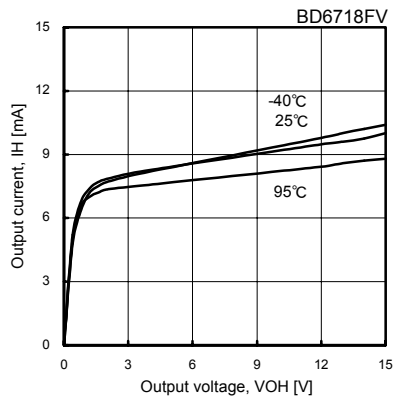

Fig.18 H side output current

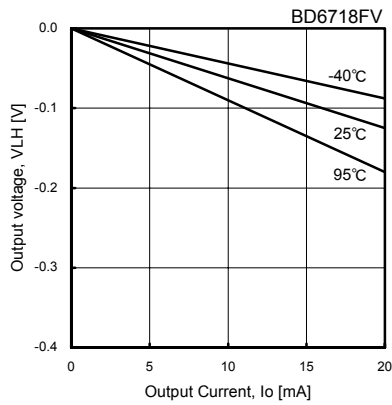

Fig.19 L side output high voltage

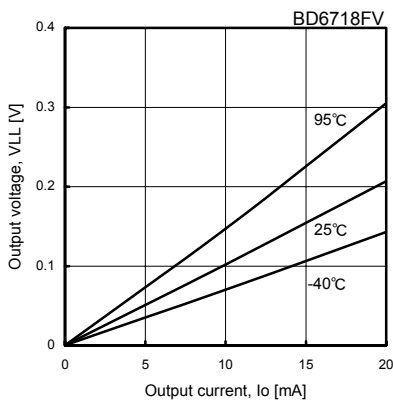

Fig.20 L side output low voltage

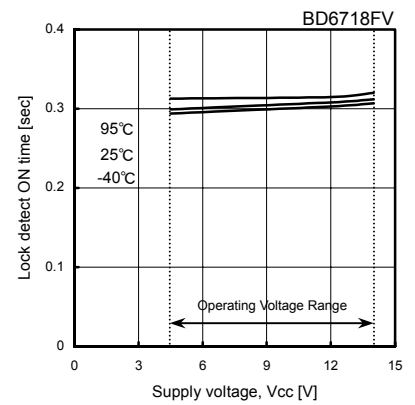

Fig.21 Lock detection ON time1,2

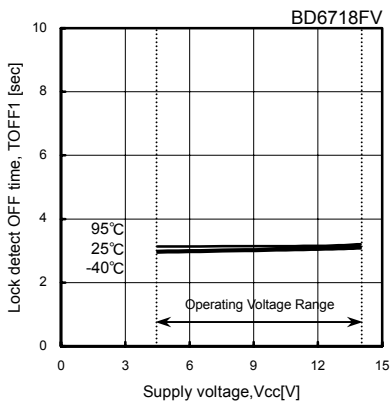

Fig.22 Lock detection OFF time1

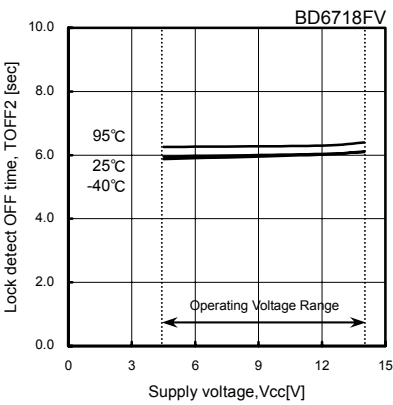

Fig.23 Lock detection OFF time2

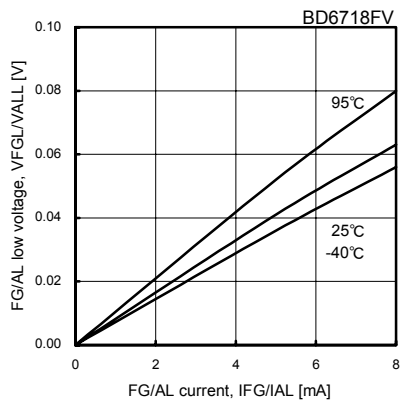

Fig.24 FG/AL low voltage

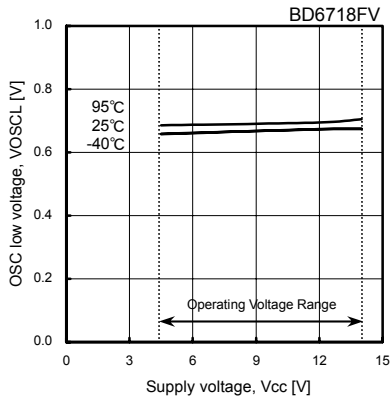

Fig.25 OSC low voltage

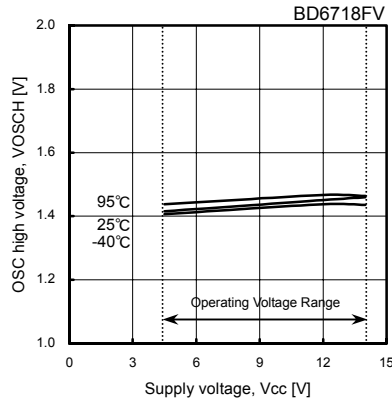

Fig.26 OSC high voltage

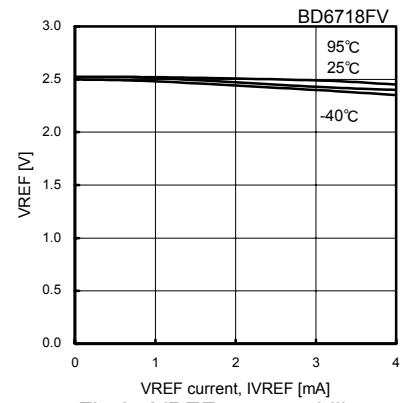

Fig.27 VREF current ability

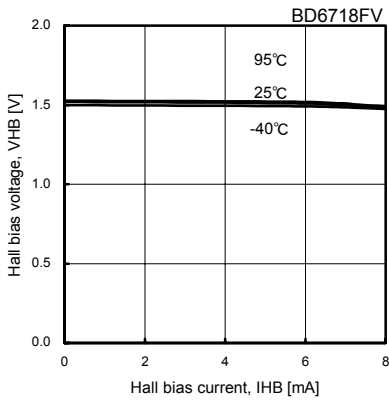

Fig.28 Hall bias current ability

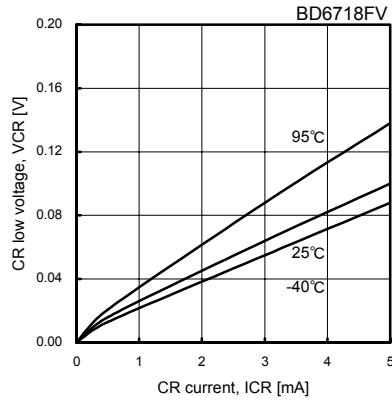

Fig.29 CR output low voltage

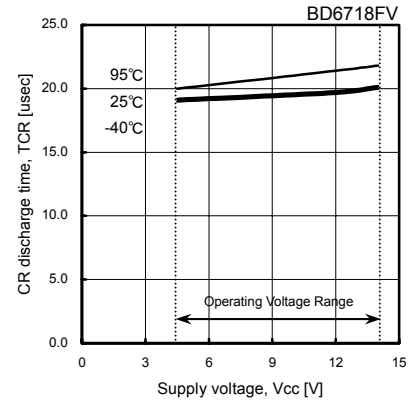

Fig.30 CR discharge time

©BD6721FS

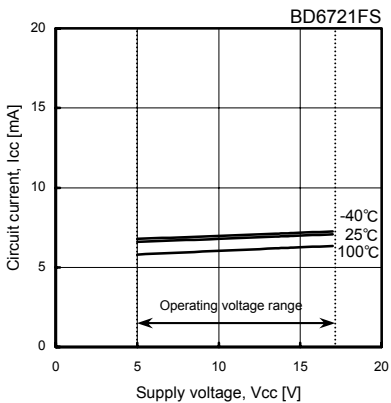

Fig.31 Circuit current

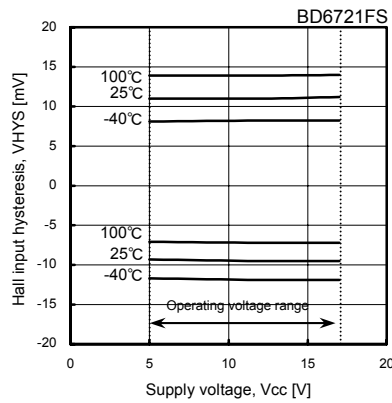

Fig.32 Hall input hysteresis

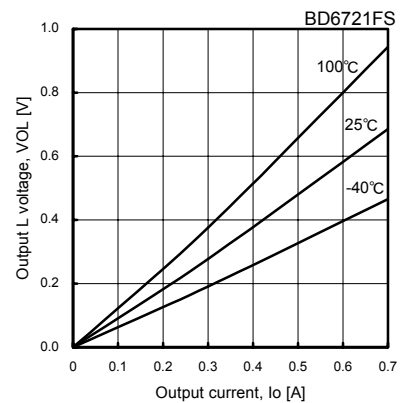

Fig.33 Output low voltage (Temperature characteristics)

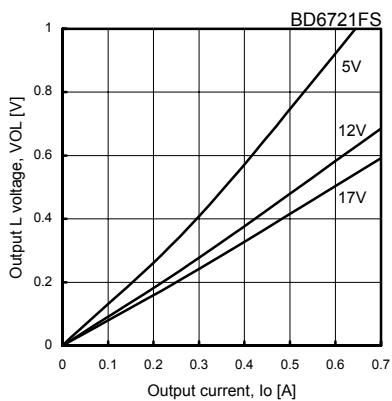

Fig.34 Output low voltage (Voltage characteristics)

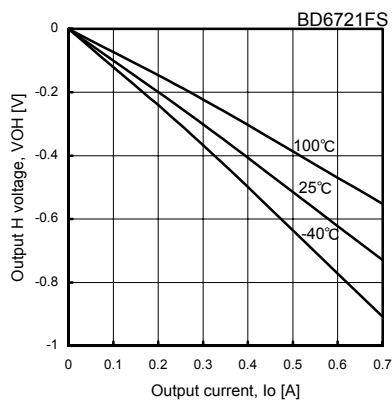

Fig.35 Output high voltage (Temperature characteristics)

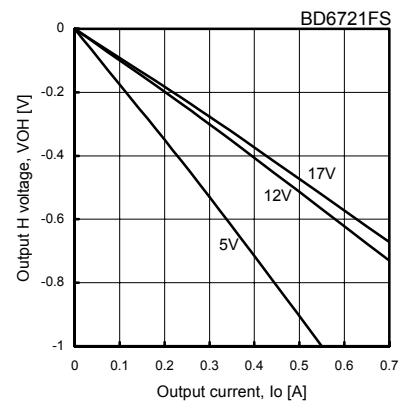

Fig.36 Output high voltage (Voltage characteristics)

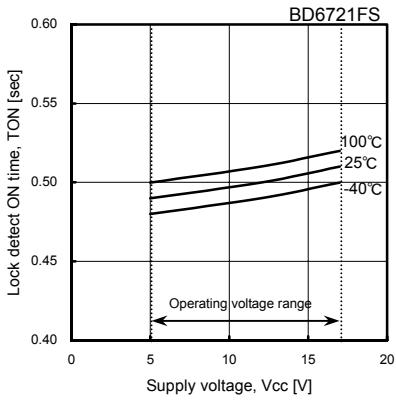

Fig.37 Lock detection ON time

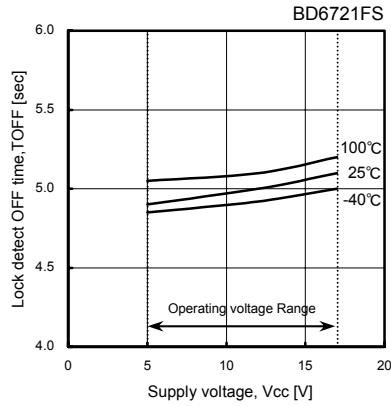

Fig.38 Lock detection OFF time

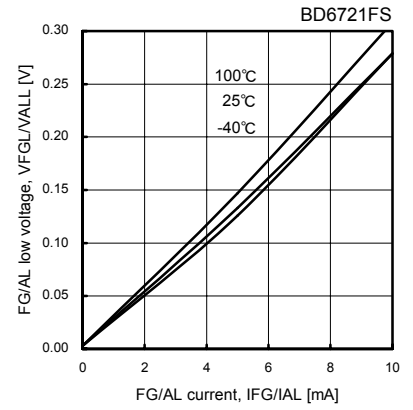

Fig.39 FG/AL low voltage (Temperature characteristics)

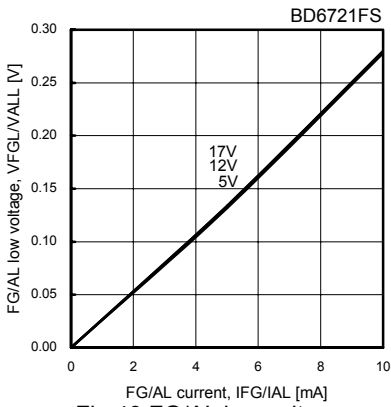

Fig.40 FG/AL low voltage (Voltage characteristics)

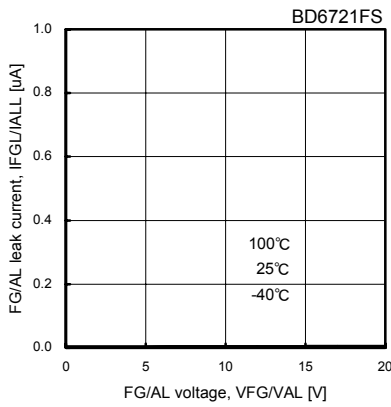

Fig.41 FG/AL leak current

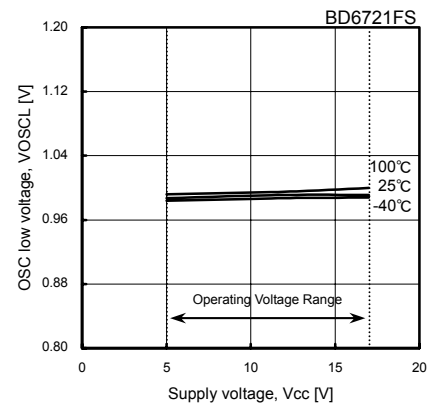

Fig.42 OSC low voltage

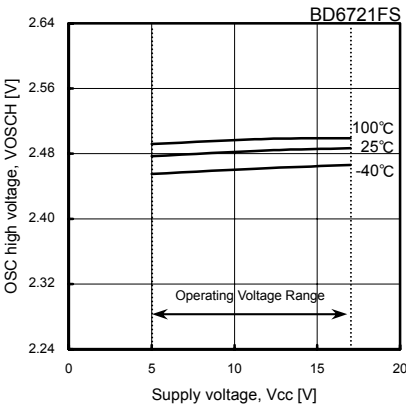

Fig.43 OSC high voltage

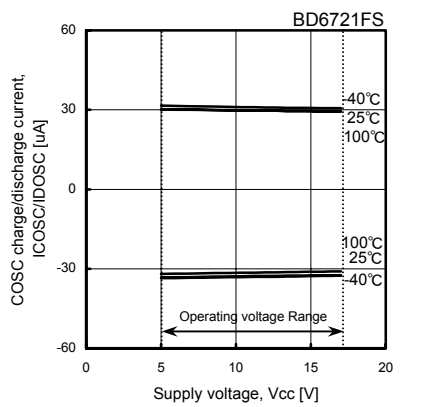

Fig.44 OSC charge/discharge current

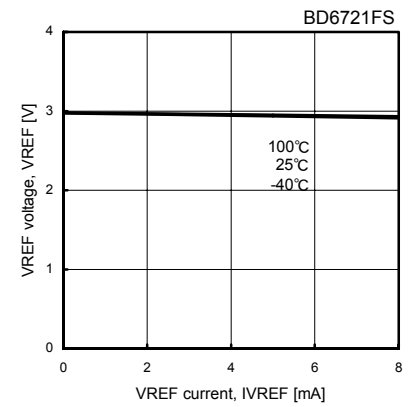

Fig.45 VREF current ability

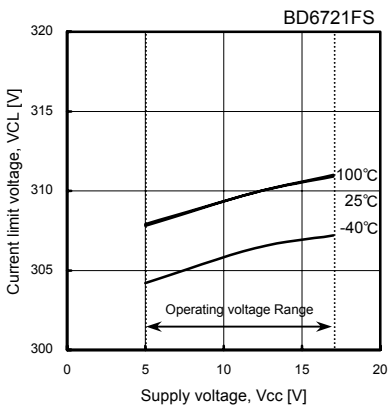

Fig.46 Current limit voltage

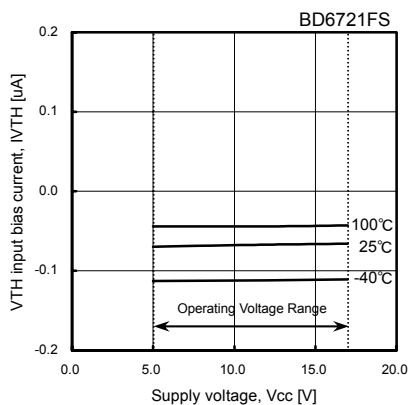

Fig.47 VTH input bias current

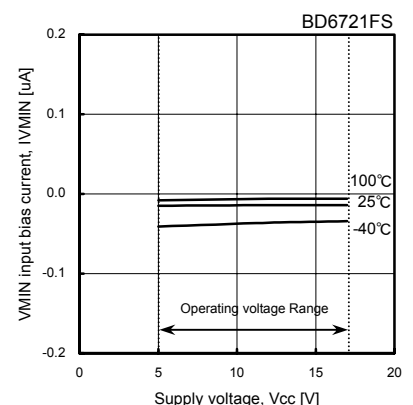

Fig.48 VMIN input bias current

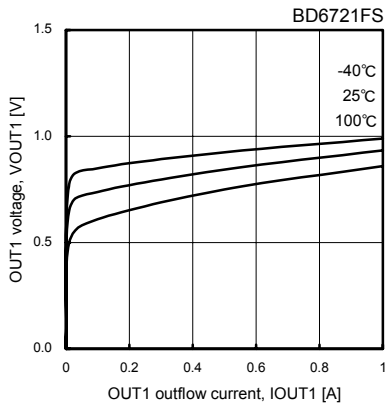

Fig.49 Low side output Body Di characteristics

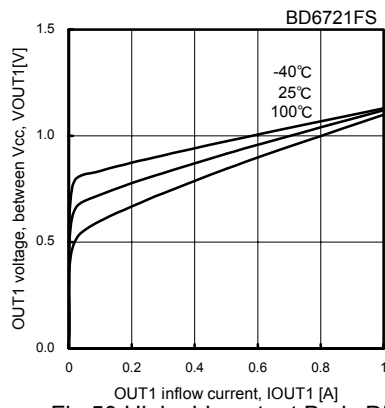

Fig.50 High side output Body Di characteristics

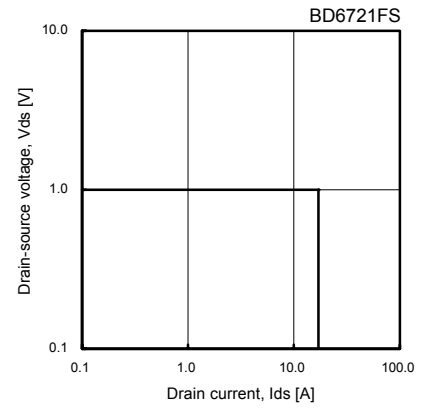

Fig.51 Output Tr ASO (upper and lower total) (TON=100msec)

©BD6722FS

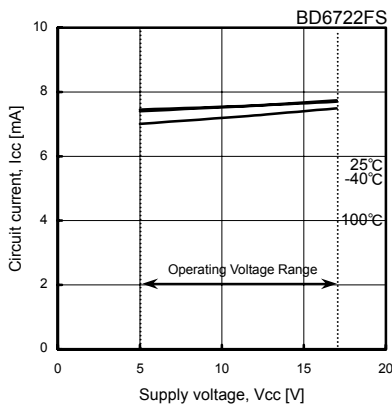

Fig.52 Circuit current

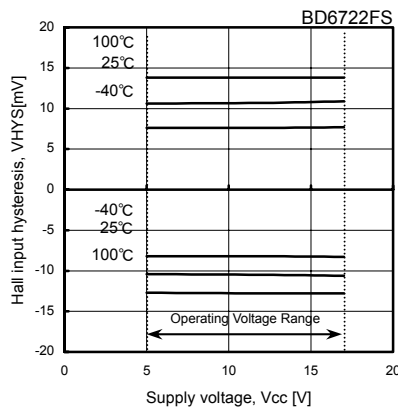

Fig.53 Hall input hysteresis

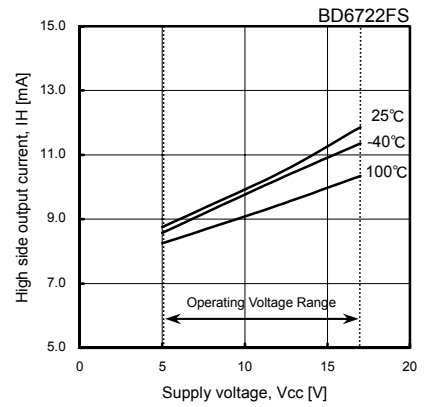

Fig.54 High side output current

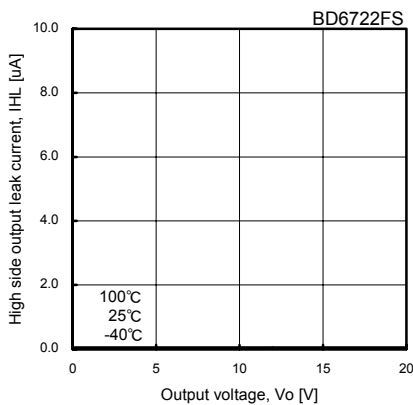

Fig.55 High side output leak current (Temperature characteristics)

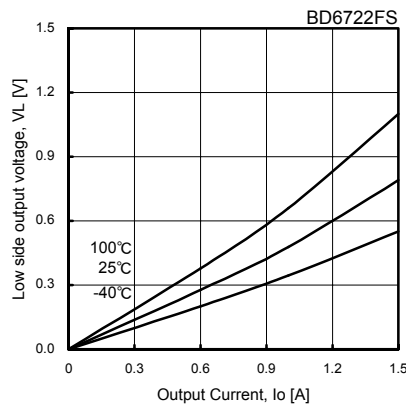

Fig.56 Low side output voltage (Voltage characteristics)

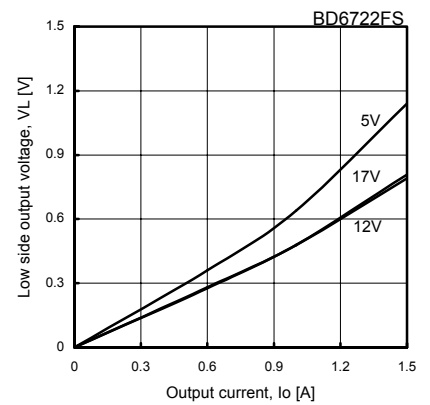

Fig.57 Low side output voltage (Voltage characteristics)

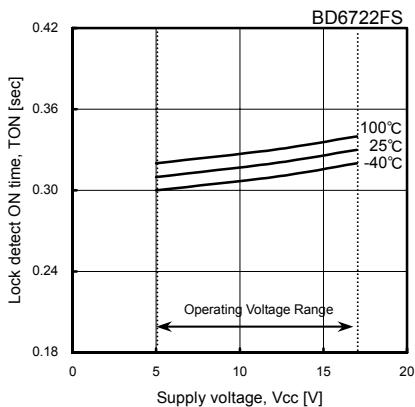

Fig.58 Lock detection ON time

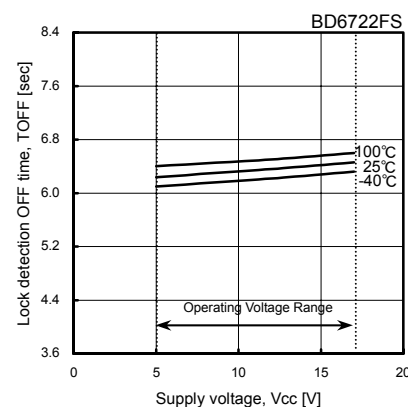

Fig.59 Lock detection OFF time

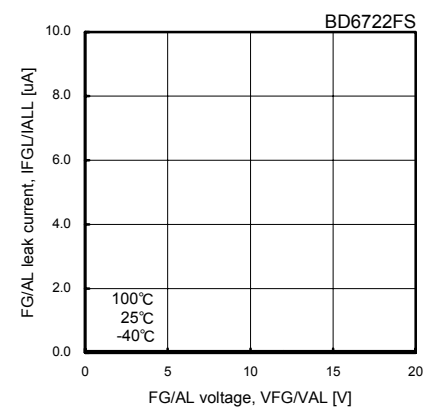

Fig.60 FG/AL leak current

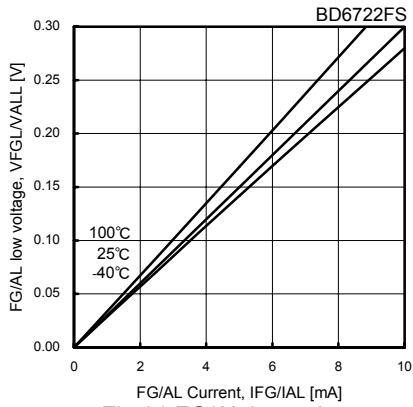

Fig.61 FG/AL low voltage (Temperature characteristics)

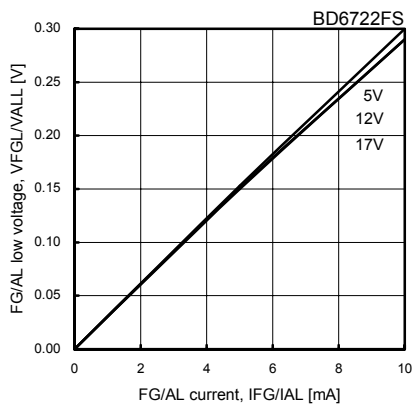

Fig.62 FG/AL low voltage (Voltage characteristics)

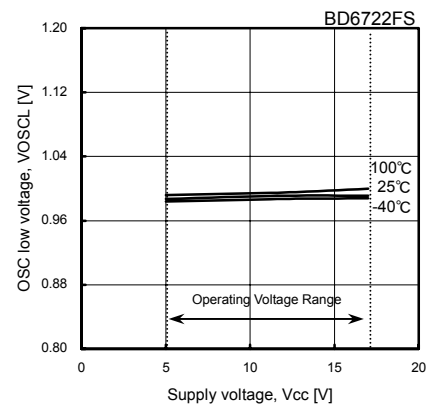

Fig.63 OSC low voltage (Voltage characteristics)

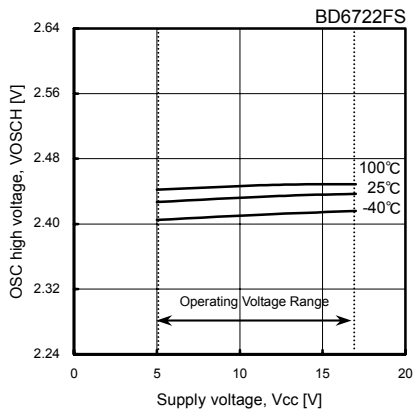

Fig.64 OSC high voltage (Voltage characteristics)

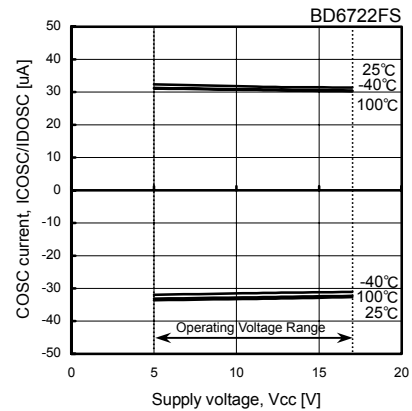

Fig.65 OSC charge discharge current (Voltage characteristics)

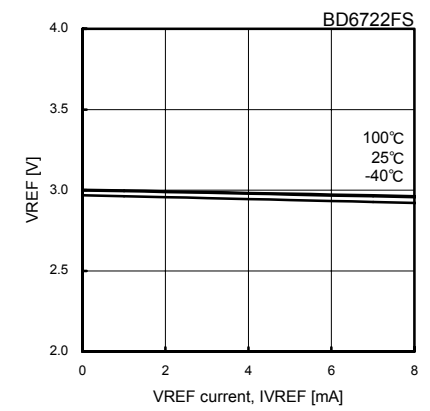

Fig.66 VREF current ability (Temperature characteristics)

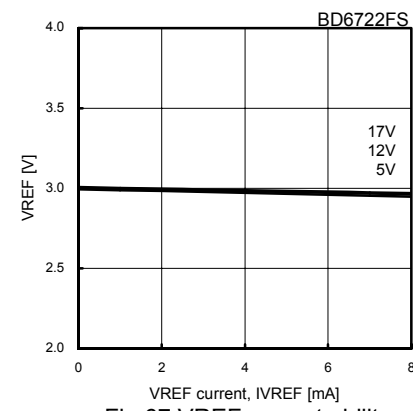

Fig.67 VREF current ability (Voltage characteristics)

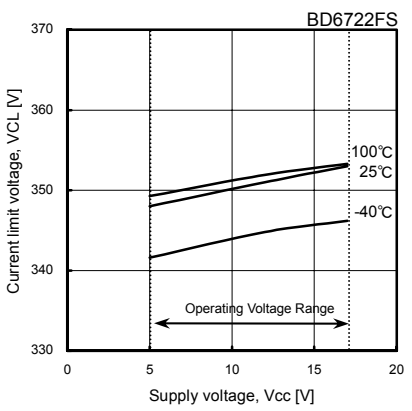

Fig.68 Current limit voltage (Voltage characteristics)

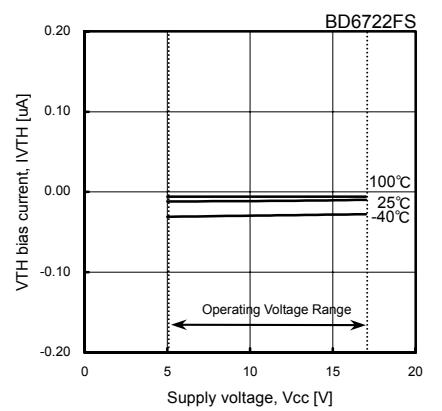

Fig.69 VTH input bias current (Voltage characteristics)

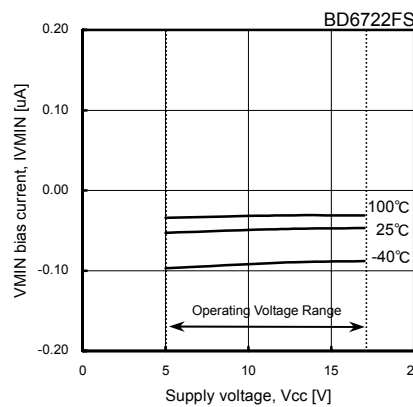

Fig.70 VMIN input bias current (Voltage characteristics)

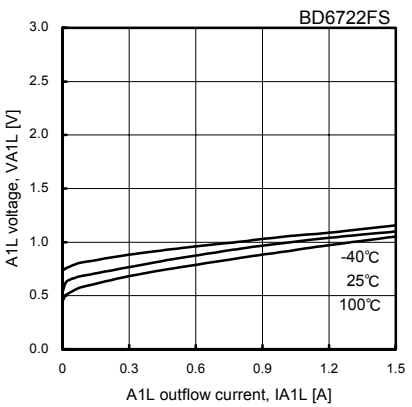

Fig.71 Low side output Body Di characteristics (Voltage characteristics)

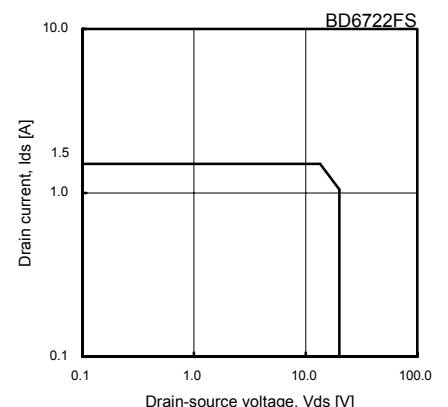

Fig.72 Low side output Tr ASO (TON=100msec) (Voltage characteristics)

●Block diagram, application circuit, and pin assignment(Constant etc are for reference)

◎BD6709FS

1) DC input application

The example of an application for rotation speed control by thermistor.

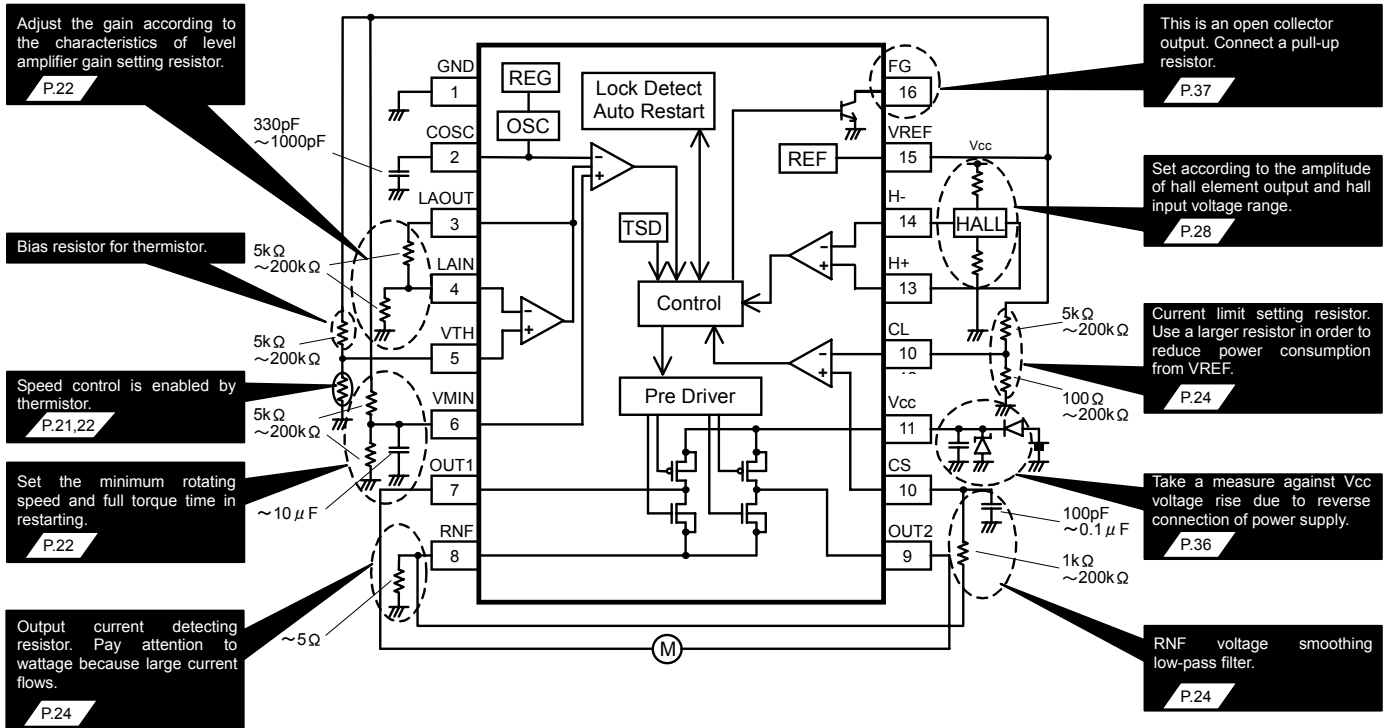

REG : Internal reference voltage    OSC : Oscillation circuit    REF : Reference voltage generating circuit

TSD : Thermal shutdown(heat rejection circuit)

PIN No.	Terminal name	Function	PIN No.	Terminal name	Function
1	GND	GND terminal	9	OUT2	Motor output terminal 2
2	COSC	Oscillating capacitor connecting terminal	10	CS	Output current detecting terminal
3	LAOUT	Level amplifier output terminal (for setting speed control gain)	11	Vcc	Power supply terminal
4	LAIN	Level amplifier input terminal (for setting speed control gain)	12	CL	Current limiting input terminal
5	VTH	Variable speed input terminal (thermistor connecting terminal)	13	H+	Hall input terminal +
6	VMIN	Minimum rotating speed setting terminal	14	H-	Hall input terminal -
7	OUT1	Motor output terminal 1	15	VREF	Reference voltage terminal
8	RNF	Output current detecting resistor connecting terminal (motor GND terminal)	16	FG	Rotating speed pulse signal output terminal

### 2) Pulse input application 1

The example of an application for converting external PWM signal into the DC voltage, and controlling the rotational speed. Minimum rotational speed can be set.

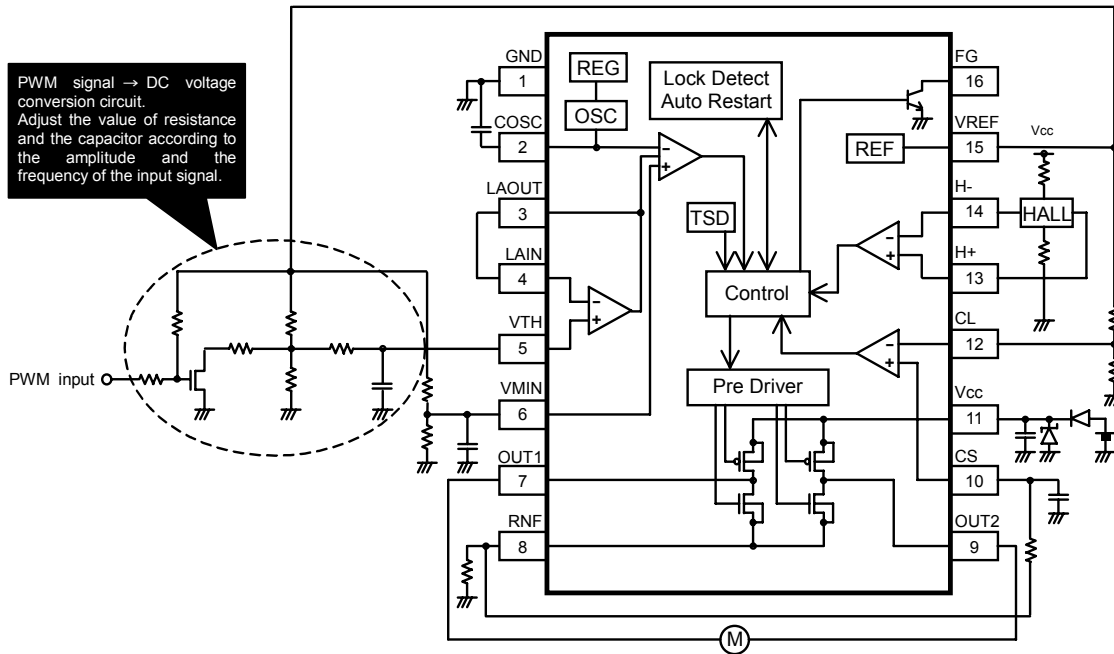

### 3) Pulse input application 2

The example of an application for controlling the rotational speed by DUTY of external PWM signal. The minimum rotational speed cannot be set.

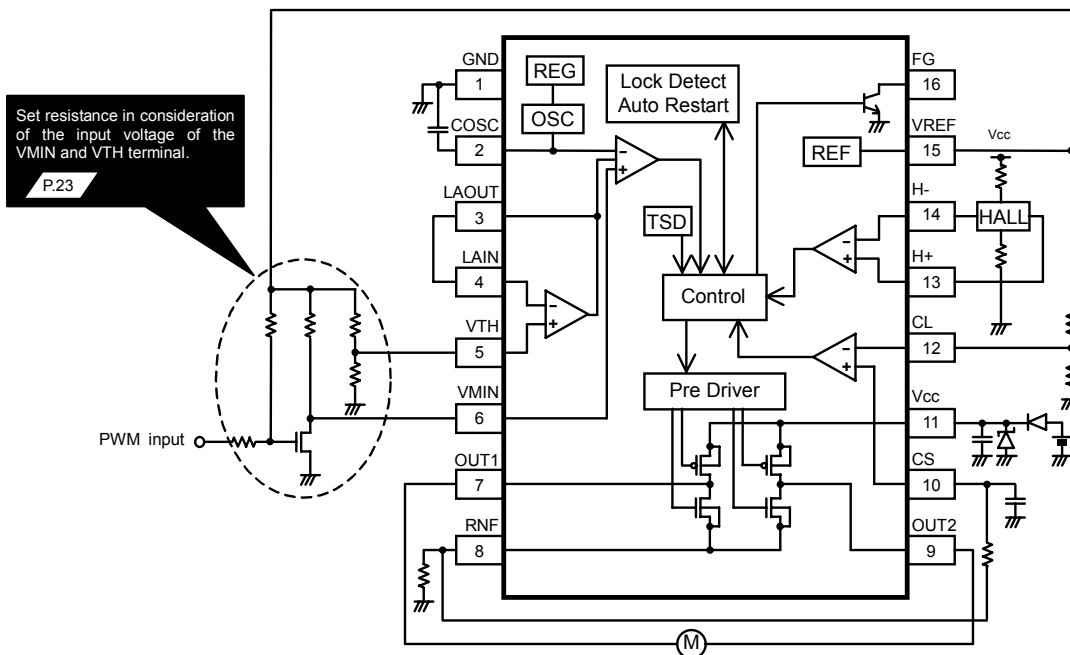

1) DC input application

The example of an application for rotation speed control by thermistor.

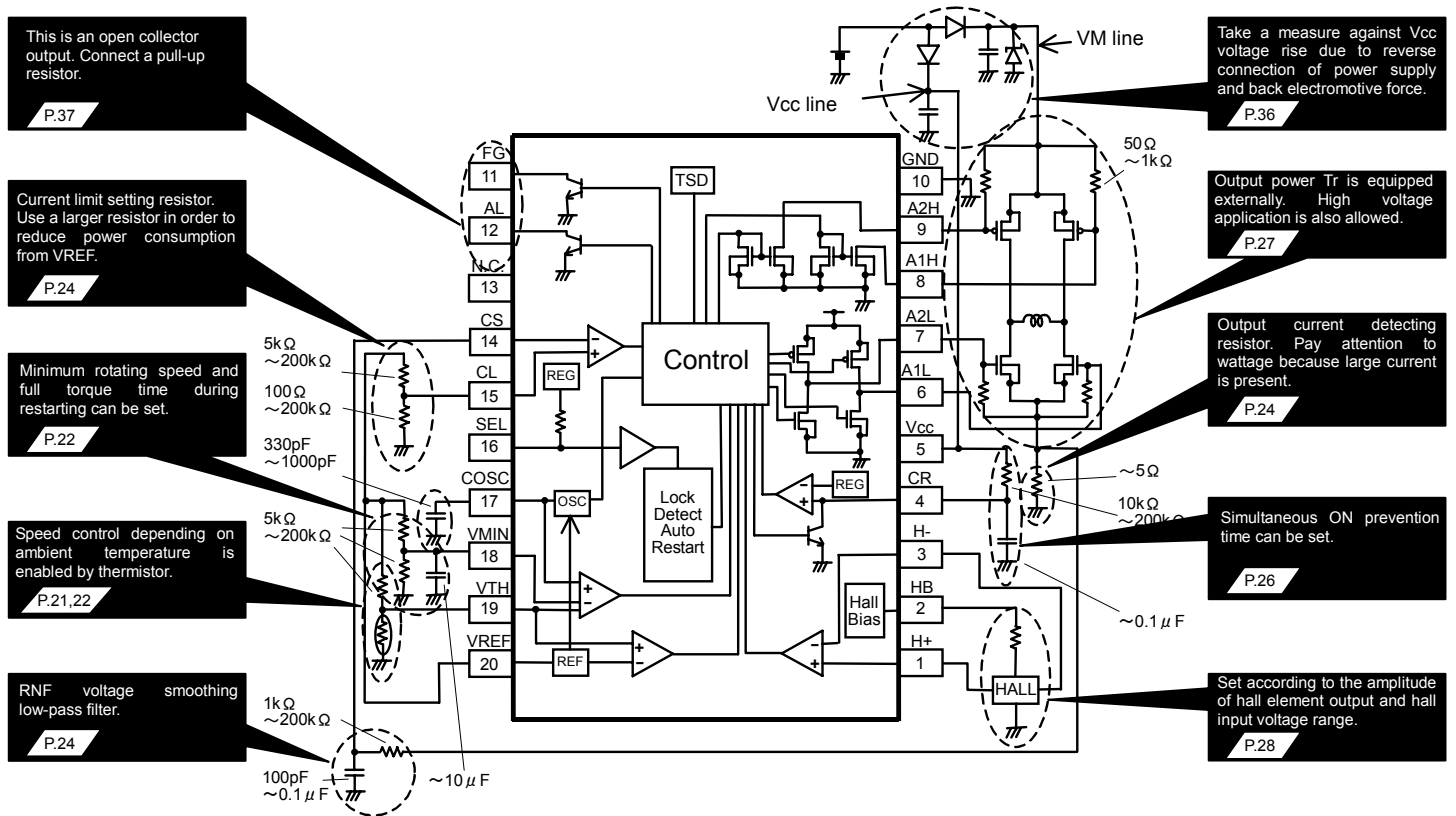

REG : Internal reference voltage    OSC : Oscillation circuit    REF : Reference voltage generating circuit  
 TSD : Thermal shutdown(heat rejection circuit)

PIN No.	Terminal name	Function	PIN No.	Terminal name	Function
1	H+	Hall input terminal +	11	FG	Rotating speed pulse signal output terminal
2	HB	Hall bias terminal	12	AL	Lock alarm signal output terminal
3	H-	Hall input terminal -	13	N.C.	
4	CR	Charging and discharging pulse circuit capacitor and resistor connecting terminal	14	CS	Output current detecting terminal
5	Vcc	Power supply terminal	15	CL	Current limiting input terminal
6	A1L	Low side output terminal (OUT1)	16	SEL	Lock detection ON:OFF ratio selecting terminal
7	A2L	Low side output terminal (OUT2)	17	COSC	Oscillating capacitor connecting terminal
8	A1H	High side output terminal (OUT1)	18	VMIN	Minimum rotating speed setting terminal
9	A2H	High side output terminal (OUT2)	19	VTH	Variable speed input terminal (thermistor connecting terminal)
10	GND	GND terminal	20	VREF	Reference voltage terminal

2) Pulse input application 1

The example of an application for converting external PWM signal into the DC voltage, and controlling the rotational speed. Minimum rotational speed can be set.

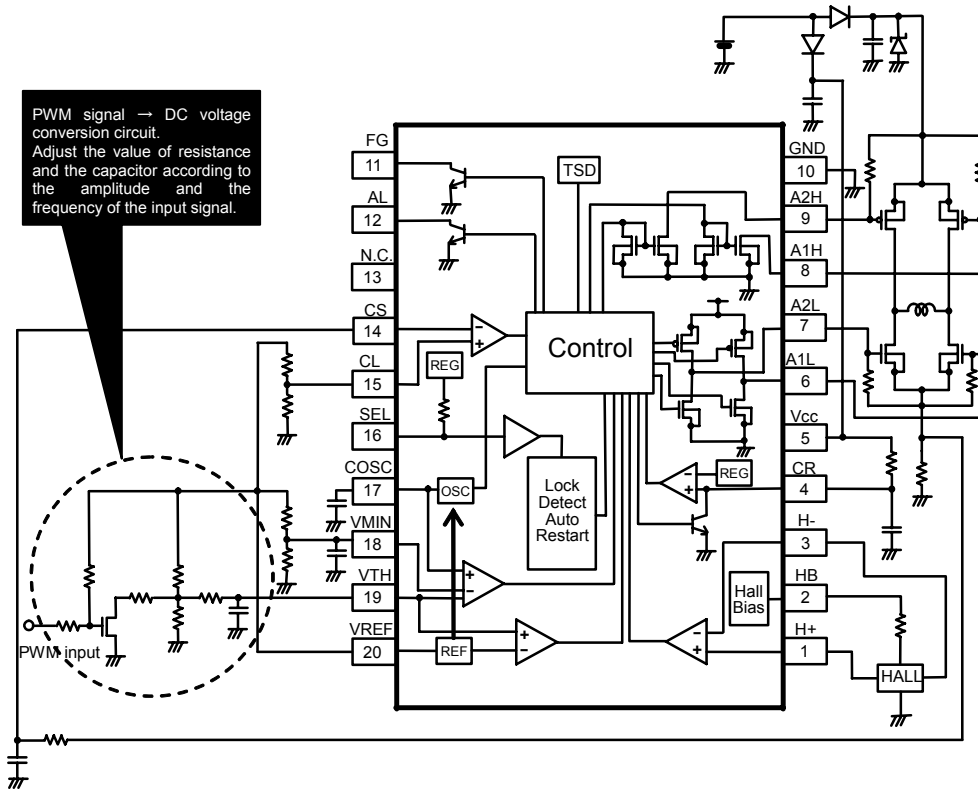

3) Pulse input application 2

The example of an application for controlling the rotational speed by DUTY of external PWM signal. The minimum rotational speed cannot be set.

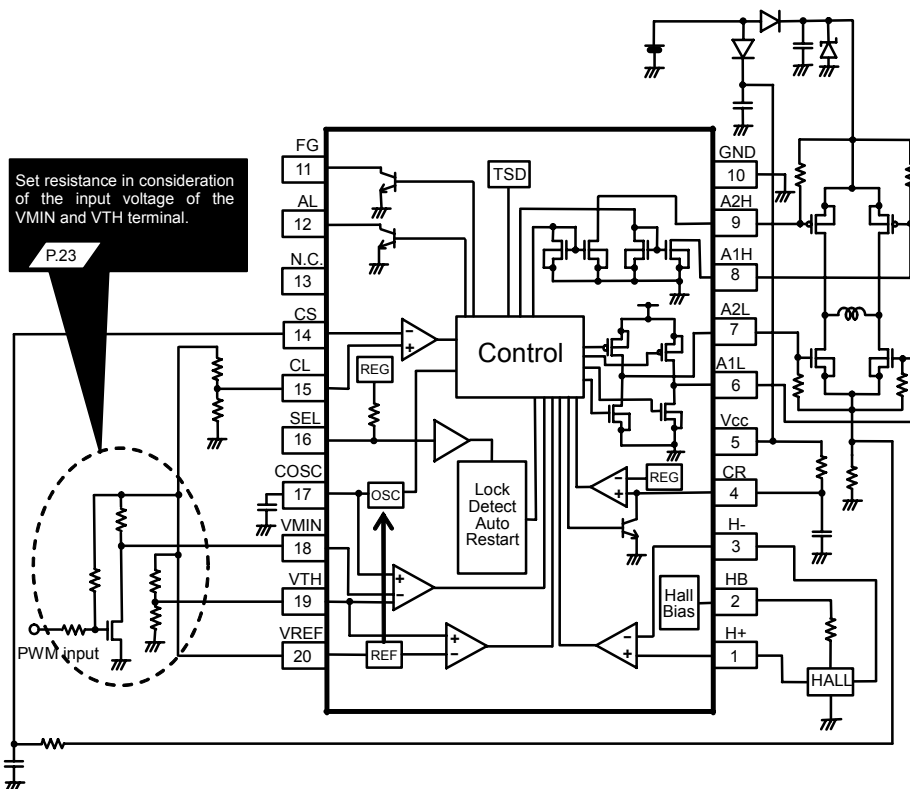

1) DC input application

The example of an application for rotation speed control by thermistor.

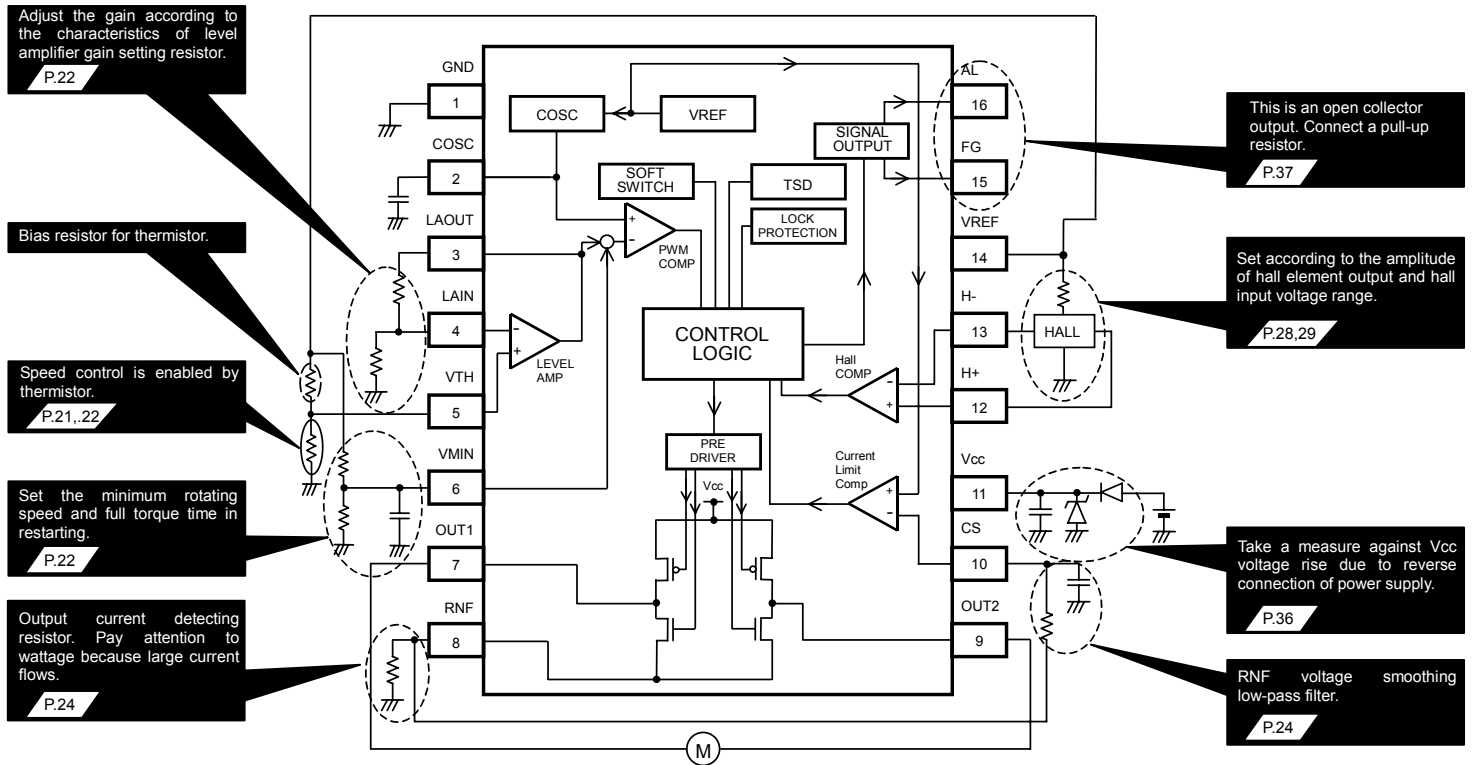

PIN No.	Terminal name	Function	PIN No.	Terminal name	Function
1	GND	GND terminal	9	OUT2	Motor output terminal 2
2	COSC	Oscillating capacitor connecting terminal	10	CS	Output current detecting terminal
3	LAOUT	Level amplifier output terminal (for setting speed control gain)	11	Vcc	Power supply terminal
4	LAIN	Level amplifier input terminal (for setting speed control gain)	12	H+	Hall input terminal +
5	VTH	Variable speed input terminal (thermistor connecting terminal)	13	H-	Hall input terminal -
6	VMIN	Minimum rotating speed setting terminal	14	VREF	Reference voltage terminal
7	OUT1	Motor output terminal 1	15	FG	Rotating speed pulse signal output terminal
8	RNF	Output current detecting resistor connecting terminal (motor GND terminal)	16	AL	Lock alarm signal output terminal

2) Pulse input application 1

The example of an application for converting external PWM signal into the DC voltage, and controlling the rotational speed. Minimum rotational speed can be set.

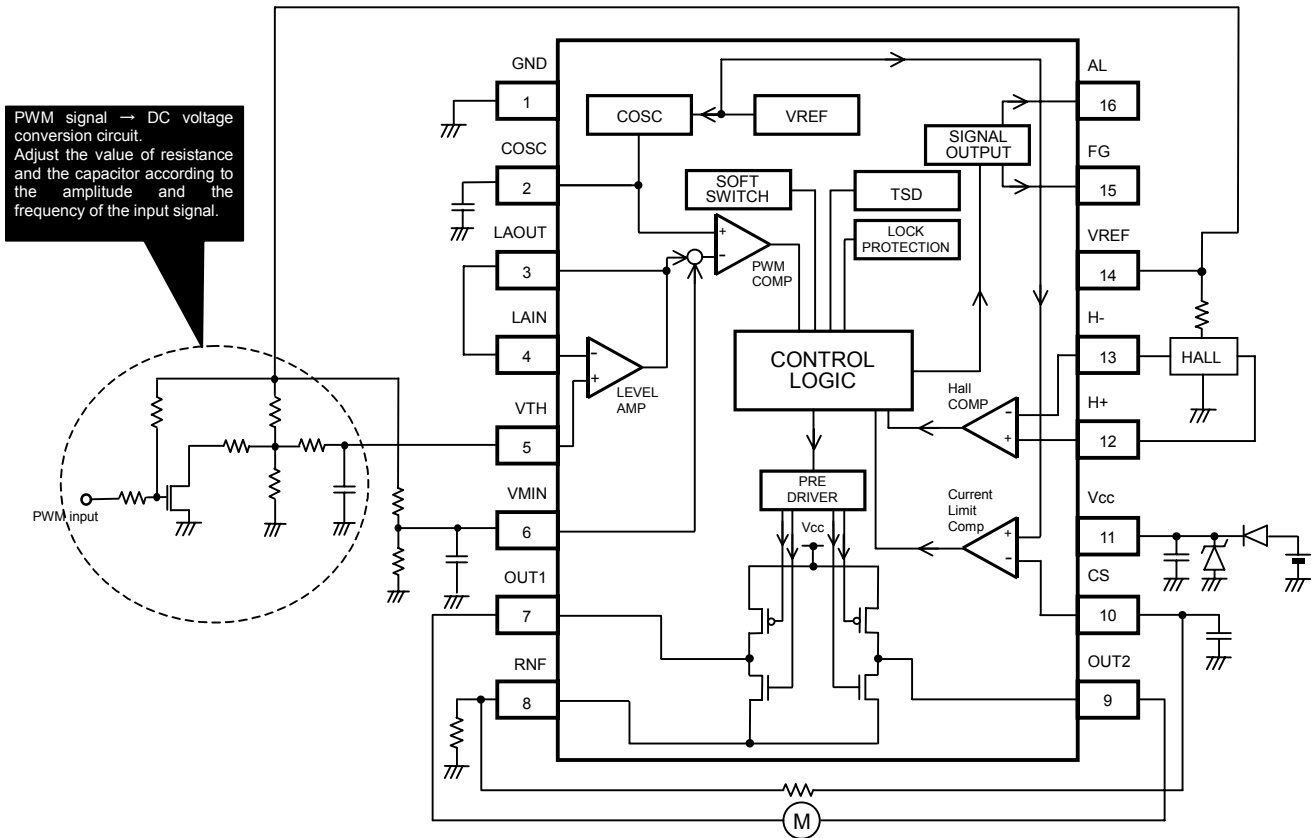

3) Pulse input application 2

The example of an application for controlling the rotational speed by DUTY of external PWM signal. The minimum rotational speed cannot be set.

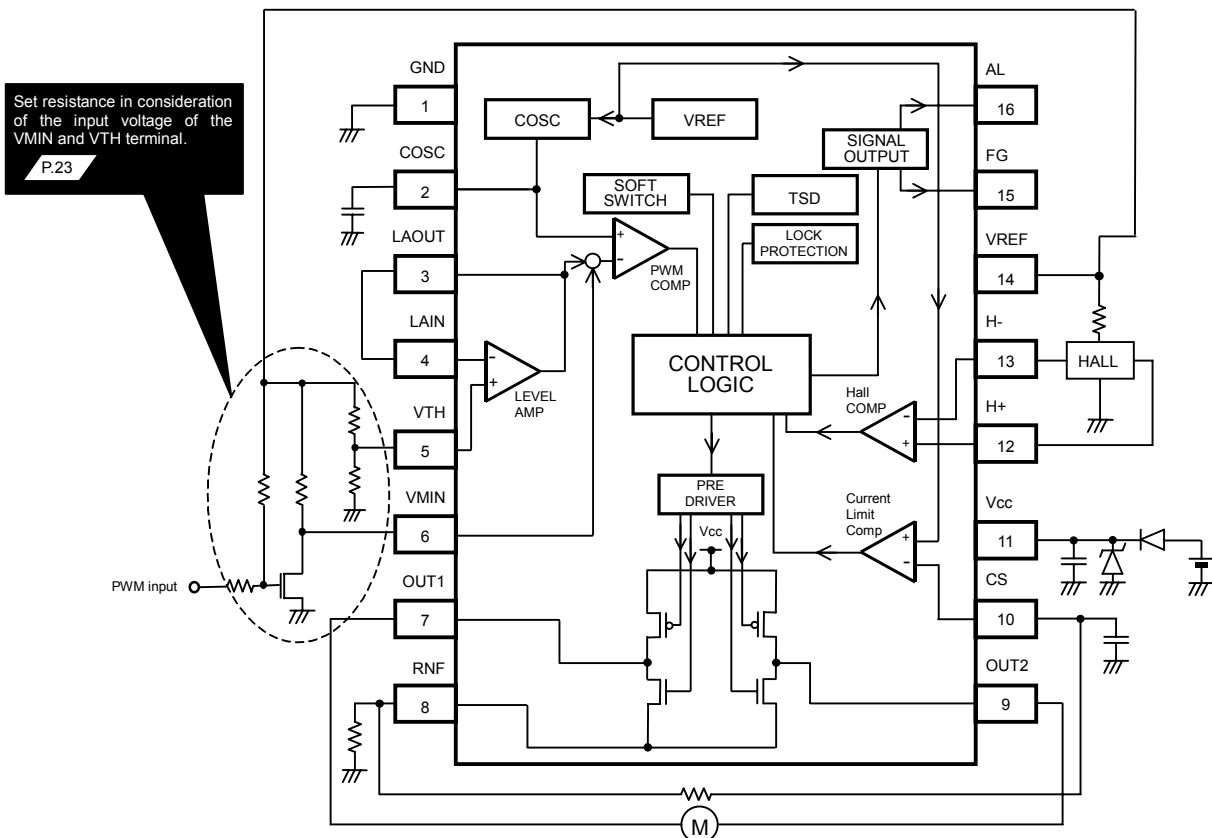

1) DC input application

The example of an application for rotation speed control by thermistor.

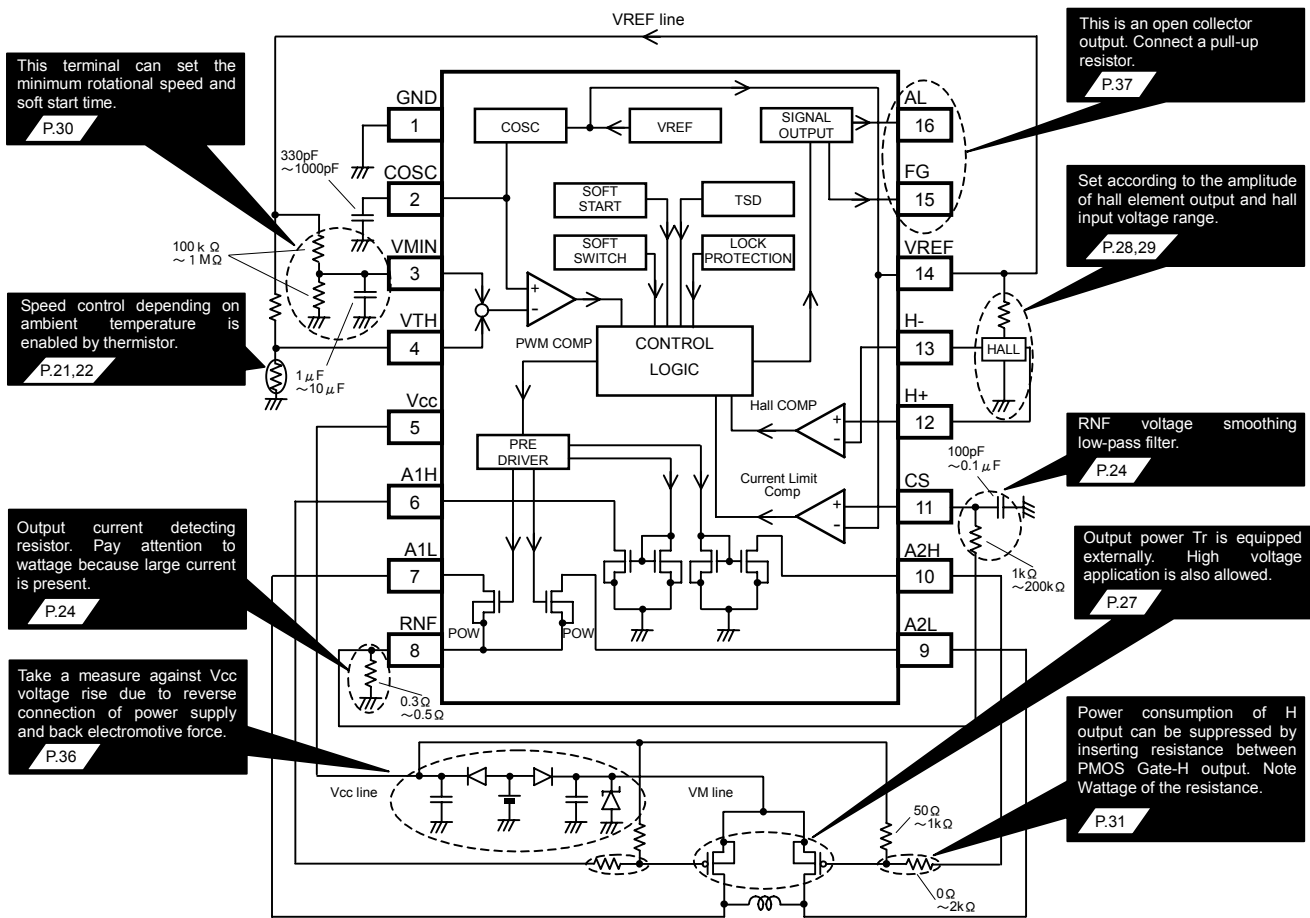

PIN No.	Terminal name	Function	PIN No.	Terminal name	Function
1	GND	GND terminal	9	A2L	Low side output terminal (OUT2)
2	COSC	Oscillating capacitor connecting terminal	10	A2H	High side output terminal (OUT2)
3	VMIN	Minimum rotating speed setting terminal	11	CS	Current limiting input terminal
4	VTH	Variable speed input terminal (thermistor connecting terminal)	12	H+	Hall input terminal +
5	Vcc	Power supply terminal	13	H-	Hall input terminal -
6	A1H	High side output terminal (OUT1)	14	VREF	Reference voltage terminal
7	A1L	Low side output terminal (OUT1)	15	FG	Rotating speed pulse signal output terminal
8	RNF	Output current detecting resistor connecting terminal (motor GND terminal)	16	AL	Lock alarm signal output terminal

2) Pulse input application 1

The example of an application for converting external PWM signal into the DC voltage, and controlling the rotational speed. Minimum rotational speed can be set.

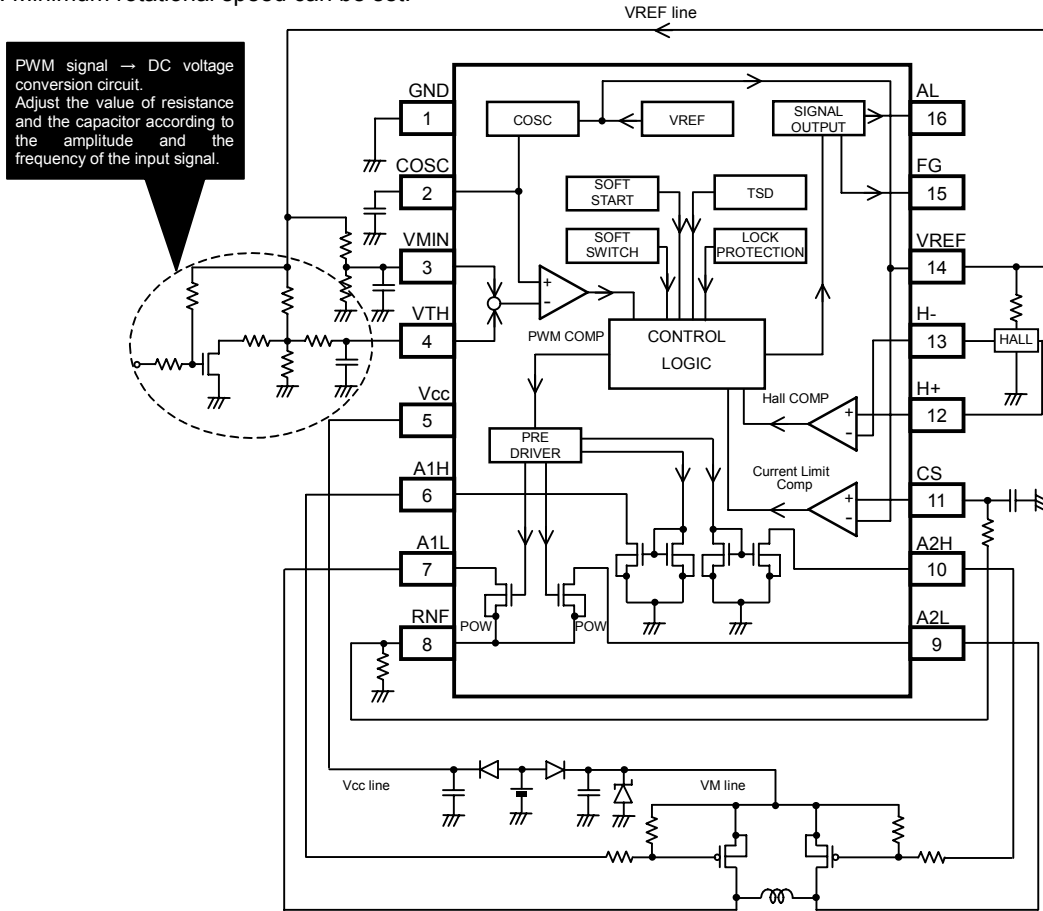

3) Pulse input application 2

The example of an application for controlling the rotational speed by DUTY of external PWM signal. The minimum rotational speed cannot be set.

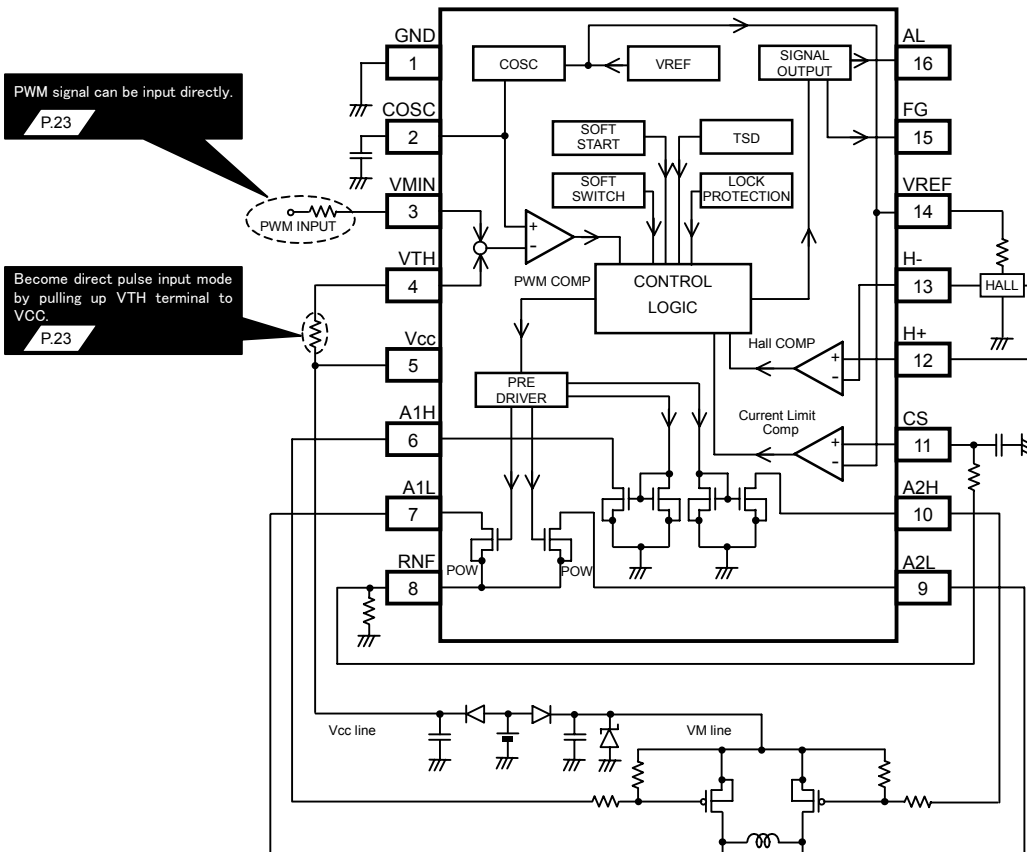

●Description of operations

Function table

		BD6709FS	BD6718FV	BD6721FS	BD6722FS	Reference page
Variable speed control	DC input	○	○	○	○	P.21,22
	PWM input	○	○	○	○	P.23
Current limit		○	○	○	○	P.24
Lock protection and automatic restart		○	○	○	○	P.25,26
Output Tr simultaneous ON preventing circuit			○			P.26
High voltage application			○		○	P.27
PWM soft switching				○	○	P.29
Soft start					○	P.30

1) Variable speed operation

Rotating speed changes by PWM ON-DUTY on the upper output.

PWM operation enables

- a) PWM operation by DC input (Method by self-oscillation connecting a capacitor to COSC terminal)
- b) PWM operation by pulse input (Method to change duty by inputting pulse directly to COSC terminal)

a) PWM operation by DC input

As shown in Fig.73, DC voltage input from LAOUT(BD6709FS, BD6721FS), or DC voltage input from VTH(BD6718FV, BD6722FS) are compared with triangle wave produced by charging and discharging current to the capacitor connected to COSC to change ON-DUTY.

Output is ON when COSC terminal voltage > VTH terminal voltage or LAOUT terminal voltage  
 Output is OFF when COSC terminal voltage < VTH terminal voltage of LAOUT terminal voltage

VMIN terminal is for setting the minimum rotating speed. ON-DUTY is determined by either VTH terminal voltage or LAOUT terminal voltage, whichever is lower.

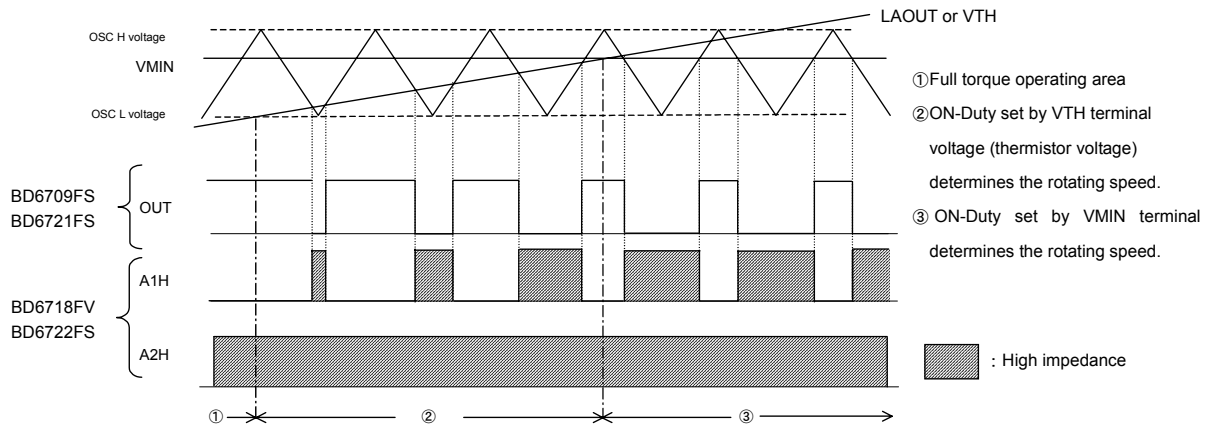

Fig.73 DC input PWM operation timing chart

COSC H and COSC L voltage is generated by dividing resistance of internal power supply, and the ratio of those voltage are designed to be hard to fluctuate.

When the input voltage at LAOUT terminal is constant, effect by fluctuation of COSCH and COSCL voltage is large. However, by setting that voltage input via VTH terminal is generated by dividing resistance of VREF terminal voltage, application can be made hard to be affected by voltage fluctuation of triangle wave. For an application which requires strict precision, determine a value with sufficient margin after full consideration of external constant is taken.

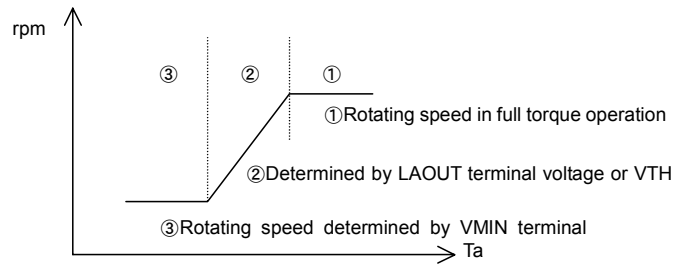

Fig.74 Setting of rotating speed

Area ① LAOUT or VTH < OSC L voltage < VMIN < OSC H voltage  
 (Same as area ① in Fig.73) Rotating speed in full torque operation (ON-DUTY = 100%)

Area ② OSC L voltage < LAOUT or VTH < VMIN < OSC H voltage  
 (Same as area ② in Fig.73) Rotating speed is determined by ON-DUTY set by LAOUT terminal voltage or VTH terminal voltage.

Area ③ OSC L voltage < VMIN < LAOUT or VTH < OSC H voltage  
 (Same as area ③ in Fig.73) Rotating speed is determined by ON-DUTY set by VMIN terminal voltage.  
 The motor can be stopped by setting OSCH voltage < VMIN (ON-DUTY = 0%).

Assuming that VTH thermistor resistor is open, when VTH terminal voltage is above VREF, full torque operation is performed.

○Level amplifier <BD6709FS, BD6721FS>

Level amplifier amplifies the voltage of VTH by the ratio of resistor connected to LAOUT and LAIN to be output to LAOUT.

In the case of Fig.75, LAOUT = (10k + 20k)/10k × VTH, and the input voltage at VTH terminal is approximately tripled.

Furthermore, when VTH terminal voltage need not be amplified, LAOUT and LAIN should be shorted as shown in Fig.76. VTH terminal voltage equals to LAOUT terminal voltage.

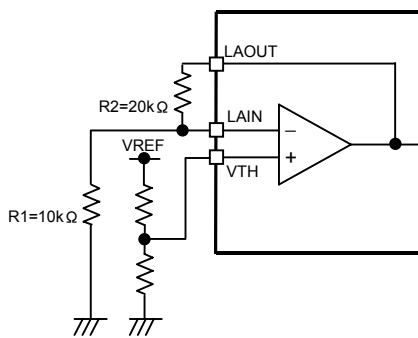

Fig.75 Level amplifier application

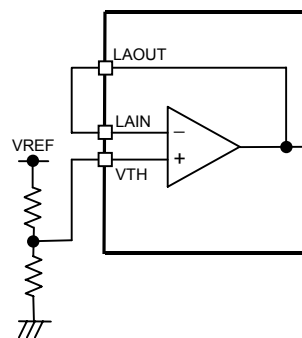

Fig.76 Level amplifier application 2

○Restart from lock protecting operation <BD6709FS, BD6718FV, BD6722FS>

When restarting from lock protection operation, VMIN becomes L so that the motor restarts in full torque.

The time for reaching full torque is determined by resistor R1 and capacitor C1 connected to VMIN terminal as shown in Fig.77.

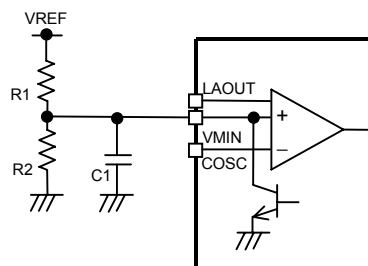

Fig.77 Restart from lock protection (DC input)

b) PWM operation by pulse input <BD6709FS, BD6718FV, BD6721FS>

Pulse signal can be input to VMIN terminal for PWM operation as shown in Fig.78.

The ratio of ON-DUTY of the output changes by the cycle of the input pulse signal as shown in Fig.79.

Set the voltage of the terminal VTH as  $V_{REF} > V_{TH} > V_{OSCH}$ .

Set the voltage input to the VMIN terminal

H level :  $V_{REF} > V_{MIN} > V_{OSCH}$

L level :  $V_{OSCL} > V_{MIN}$

as shown in Fig.79.

Output is ON in H logic of external PWM signal and OFF in L logic.

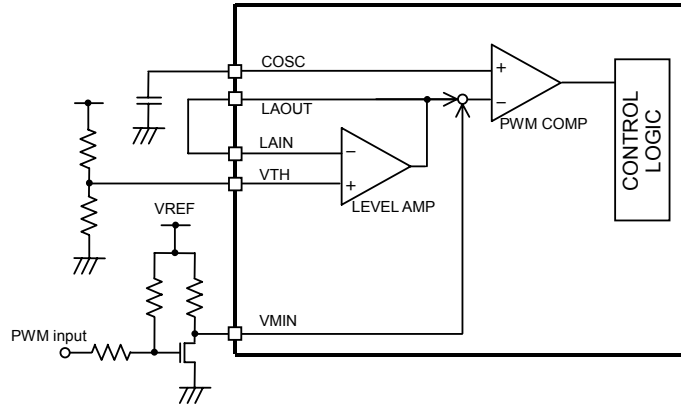

Fig.78 Direct control by DUTY of external PWM

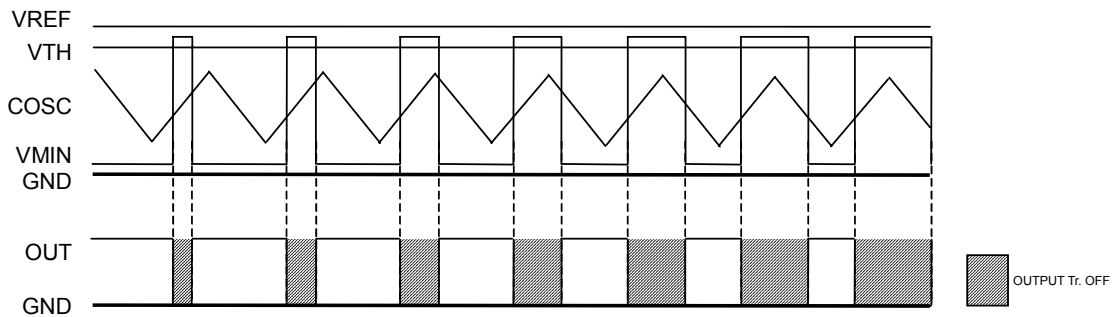

Fig.79 VTH, VMIN input voltage and output PWM timing chart in pulse input mode

b-2) PWM operation by pulse input <BD6722FS>

By pulling up VTH(4PIN) to Vcc as shown in Fig.80, the output can operate in PWM by inputting the pulse signal directly to VMIN(6PIN). However, adjust the value of R2 to become  $V_{TH} = 15V$  at  $V_{cc} \geq 15V$  so that the voltage of the terminal VTH should not exceed 15V.

The ratio of ON-DUTY of the output changes by the cycle of the input pulse signal as shown in Fig.81.

Set the voltage input to the VMIN terminal

H level :  $V_{cc} - 2.0V > V_{MIN} > V_{OSCH}$

L level :  $V_{OSCL} > V_{MIN}$

as shown in Fig.81.

Output is ON in H logic of external PWM signal and OFF in L logic.

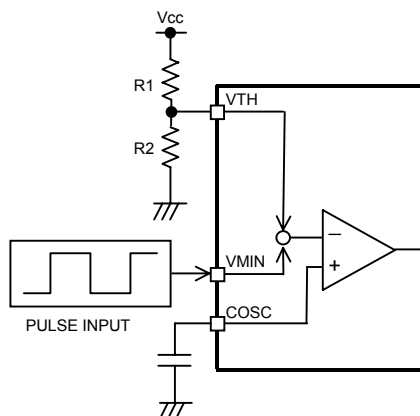

Fig.80 External PWM signal input

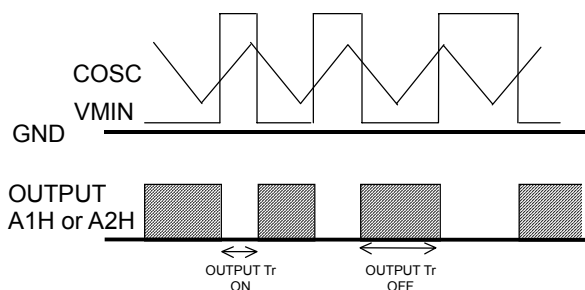

Fig.81 Pulse input operation timing chart

## 2) Current limit (current limiting circuit)

The current limit circuit turns off the output, when the current that flows to the motor coil is detected exceeding a set value.

The current value that current limit operates is determined by

- Voltage of CL terminal and voltage of RNF terminal (BD6709FS, BD6718FV)
- Internal setting voltage and voltage of RNF terminal (BD6721FS, BD6722FS)

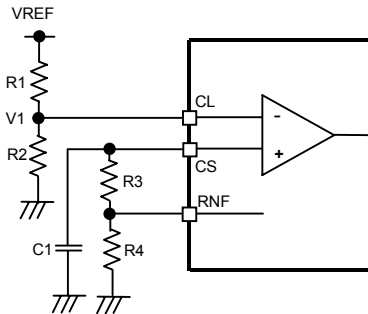

Fig.82 External setting of current limit voltage

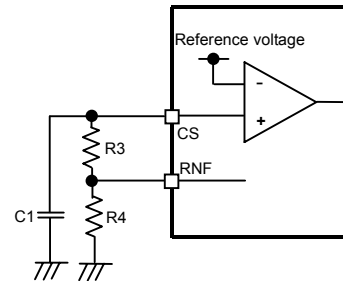

Fig.83 Internal setting of current limit voltage

- Setting according to voltage of CL terminal and RNF terminal.

For example about BD6718FV, in Fig.82

When  $R1=40k\Omega$ 、 $R2=10k\Omega$ 、 $R4=0.5\Omega$ , the amperage  $I$  that current limit operates is

$$V1 = \frac{R2}{R1+R2} \times VREF = \frac{10k}{40k + 10k} \times 2.5 = 0.5V$$

$$I = \frac{V1}{R4} = \frac{0.5}{0.5} = 1A$$

Current limit circuit operates at 1A.

Short CL terminal to VREF, short CS and RNF terminal to GND when the current limit function is not used.

- Setting according to internal voltage and RNF terminal.

For example about BD6722FS, in Fig.83

When  $R4=0.33\Omega$ , the current limit setting voltage is 350mV(typ.)

$$I = \frac{350mV}{0.33\Omega} = 1.06A$$

Current limit circuit operates at 1.06A.

Short CS and RNF terminal to GND when the current limit function is not used.

Both of a) and b)

$R3$  and  $C1$  are low-pass filters for RNF smooth voltage. Adjust for a current limit not to malfunction in proportion to the PWM frequency.

Connect the capacitor with the COSC terminal to do the resume operation after a current limit operates at the PWM operation by the pulse input.

### 3) Lock protection and automatic restart

Motor rotation is detected by hall signal, and lock detection ON time (TON) and lock detection OFF time (TOFF) are set by the IC internal counter. Timing chart is shown in Fig.84.

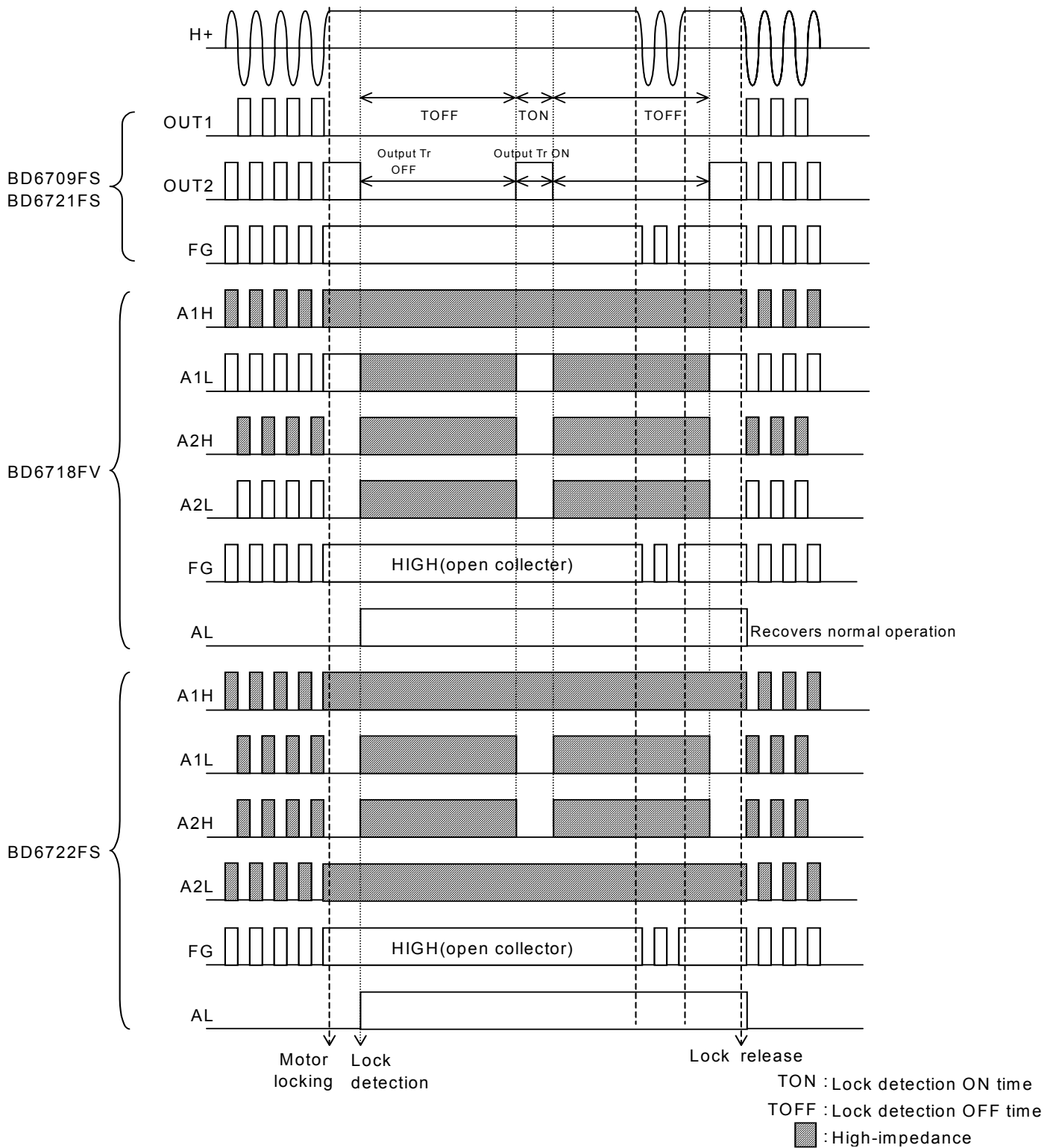

Fig.84 Lock protection (incorporated counter system) timing chart

\* For BD6718FV, lock detection time (TOFF) setting can be changed by SEL terminal.  
(See the electric characteristics item)

\* BD6721FS, BD6722FS

When torque off logic is input by the control signal during fixed time (typ. 1ms), the lock protection function becomes off. It is not influenced at the lock protection time and it is possible to restart at once.

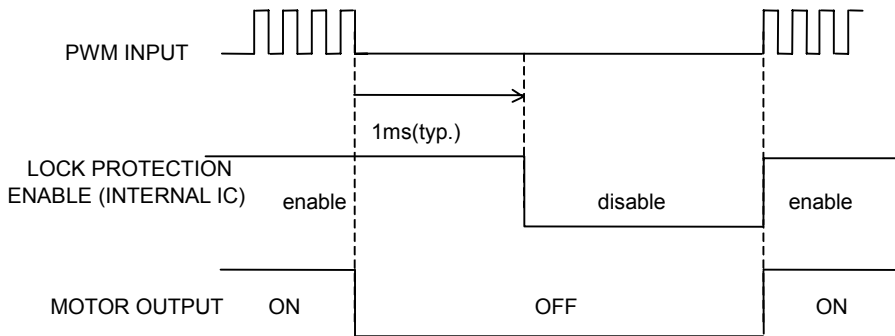

Fig.85 PWM signal and lock protection operation<BD6722FS>

The lock protection function doesn't work in an input frequency that is slower than 1kHz(typ.) when assuming H level DUTY≒0% of the PWM input signal.

Input signal that frequency are faster than 2kHz.

#### 4) Output Tr simultaneous ON prevention circuit <BD6718FV>

The capacitor is discharged according to the cycle of hall signal by connecting an external capacitor and resistor to CR terminal.

When CR terminal voltage is lower than internal reference voltage (2.5V:typ), IC output has a high impedance. High impedance block in output switching can be changed by changing the capacitance and resistance to be connected to CR terminal. It allows prevention of simultaneous activation, regardless of switching speed of external Tr.

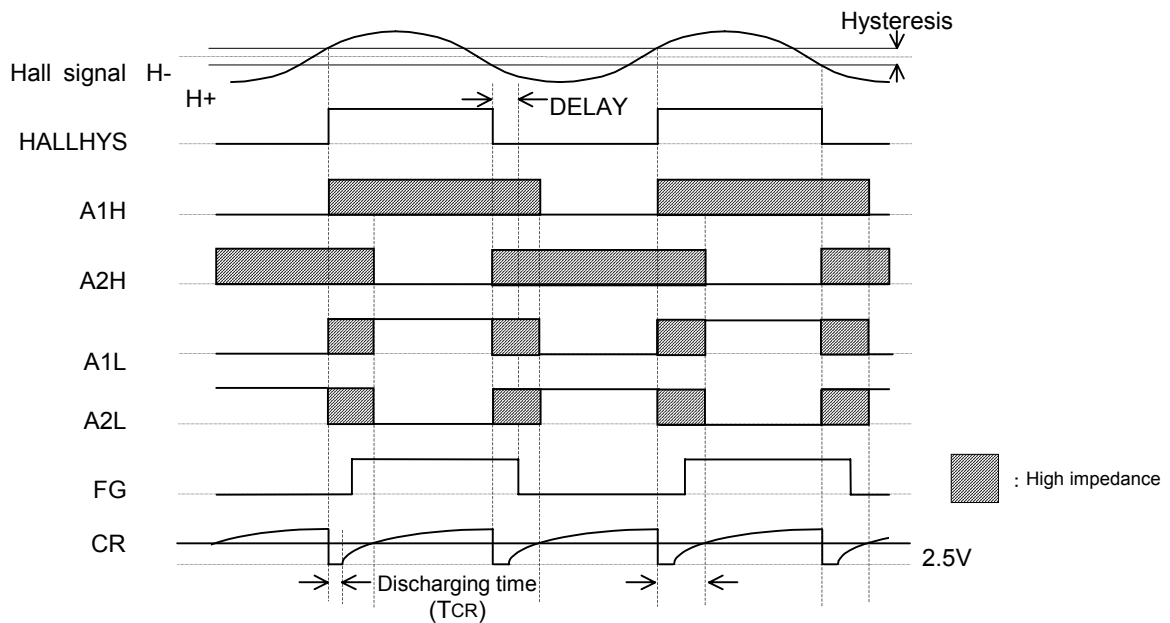

5) High voltage application <BD6718FV>

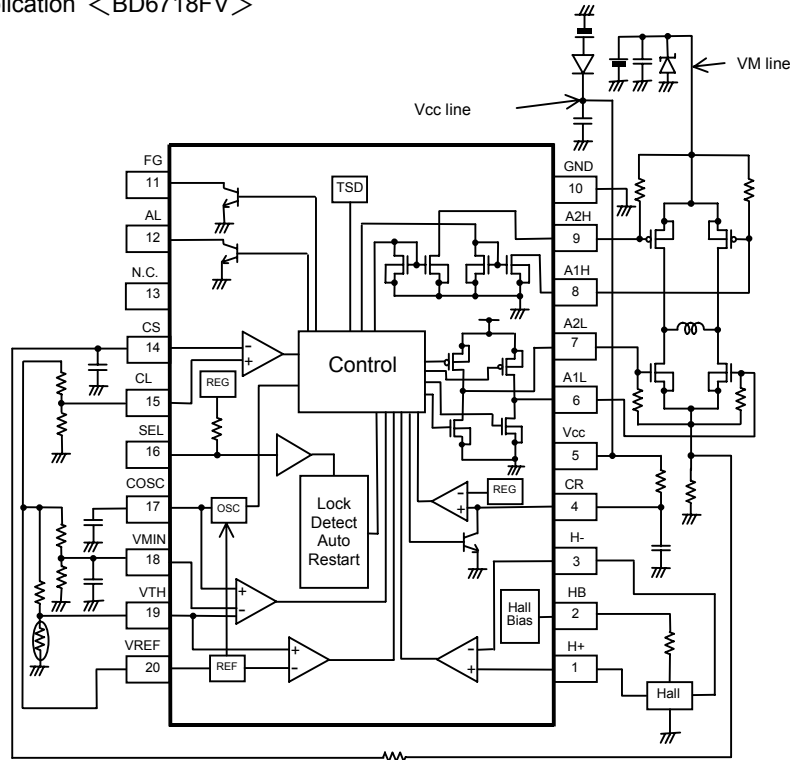

Fig.87 High voltage application (BD6718FV)

The absolute maximum rating of Vcc is 15V, while the absolute maximum rating of A1H and A2H terminal voltage is 36V. Therefore it is possible to make VM line an application with another power supply higher than 15V. To ensure the absolute maximum rating 36V of A1H and A2H terminal voltage is not exceeded, take physical measures, such as placing a Zener diode or a capacitor to create a return route of current between VM line and GND.

<BD6722FS>

The absolute maximum rating of Vcc is 20V, while the absolute maximum rating of A1H, A2H, A1L and A2L terminal voltage is 34V. Therefore it is possible to make VM line an application with another power supply higher than 20V. To ensure the absolute maximum rating 34V of A1H, A2H, A1L and A2L terminal voltage is not exceeded, take physical measures, such as placing a Zener diode or a capacitor to create a return route of current between VM line and GND.

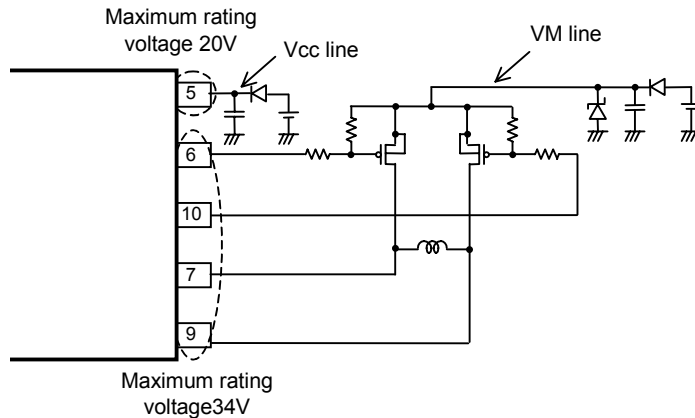

Fig.88 High voltage application (BD6722FS)

6) Hall input setting

Hall input voltage range is shown in operating conditions.

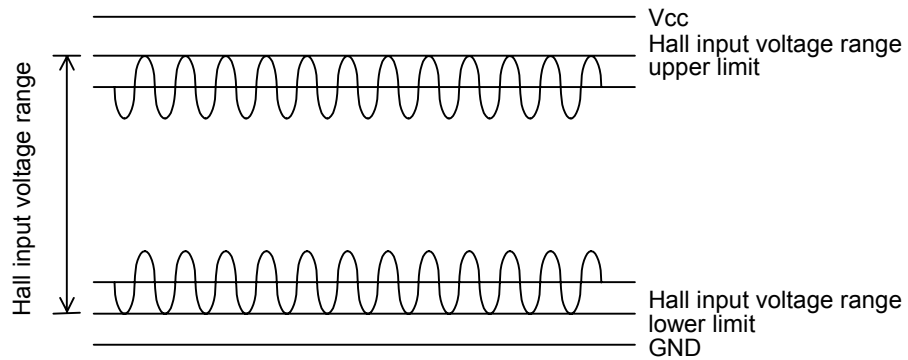

Fig.89 Hall input voltage range

Adjust the value of hall element bias resistor R1 and R2 in Fig.90 so that the input voltage of a hall amplifier is input in "hall input voltage range" including signal amplitude.

○Reducing the noise of hall signal

Hall element may be affected by Vcc noise or the like depending on the wiring pattern of board. In this case, place a capacitor like C1 in Fig.90. In addition, when wiring from the hall element output to IC hall input is long, noise may be loaded on wiring. In this case, place a capacitor like C2 in Fig.90.

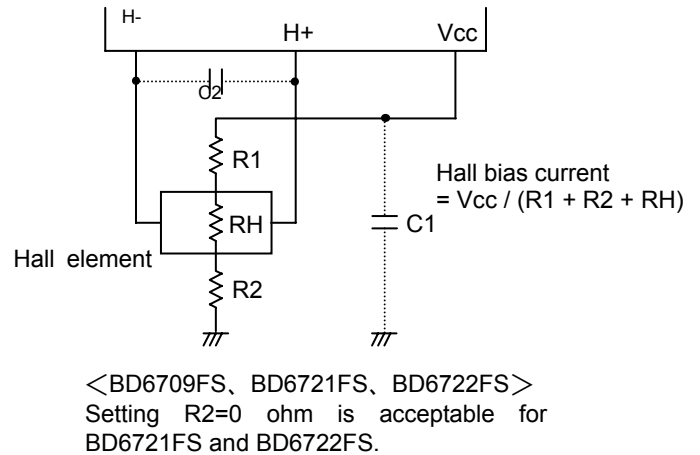
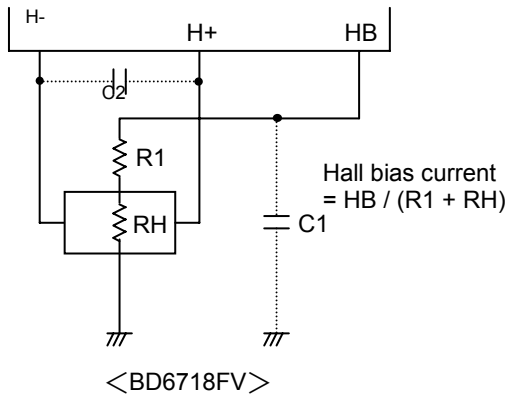

Fig.90 Application near hall signal

7) PWM soft switching<BD6721FS, BD6722FS>

The soft switching section is set to the timing before and after the change of the hall signal. The length of the soft switching section can be changed by adjusting the amplitude of the hall signal. The soft switching section becomes long if the amplitude of the hall signal is reduced, and the gradient of the output current becomes smooth. However, when a soft switching is applied too much, torque shortage might be caused. Therefore, set to the hall signal amplitude about 100mVpp that the reversely electromotive voltage is suppressed appropriately.

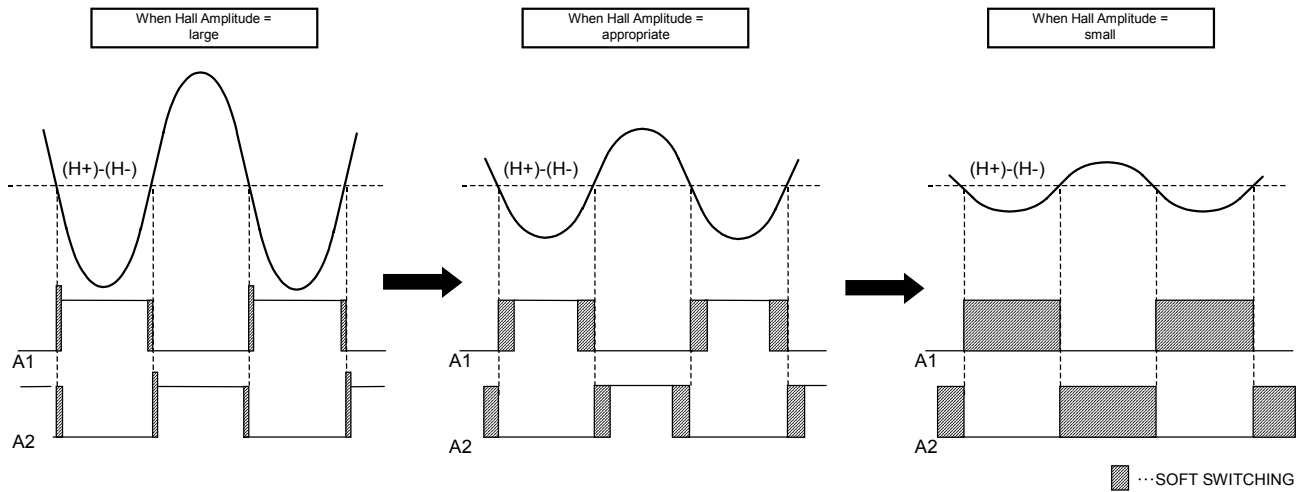

Fig.91 Relation between hall signal amplitude and output wave

The soft switching function operates in the DC input application and the pulse input application. Adjust the hall bias resistance so that the hall signal amplitude become large when you do not want to use the soft switching function.

8) Soft start<BD6722FS>

The soft start section is set at the rotation start or the LOCK protection release, etc.

The soft start time is decided by the constant circuit connected with VMIN terminal.

And VMIN terminal is used as the lowest rotational speed setting. Set VMIN to 1.75V or more (lowest rotational speed DUTY $\leq$ 50%).

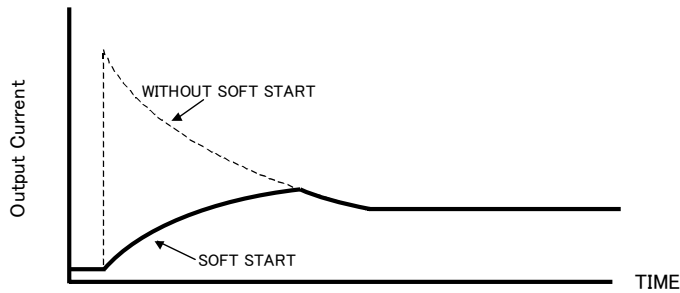

Fig.92 Output current characteristic by soft start

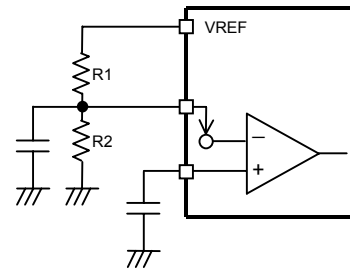

Fig.93 Soft start setting circuit

a) Soft start time of VTH setting DUTY $\geq$ 50%

It gradually rises to the DUTY set with VTH after it starts.

Fig.94 shows the soft start operation at VTH setting DUTY=70% and VMIN setting DUTY=20%.

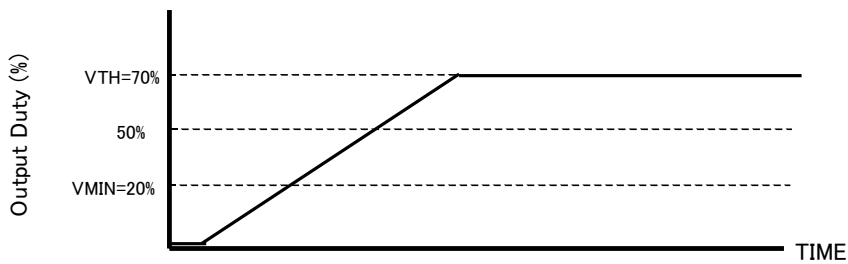

Fig.94 Soft start time chart of DUTY $\geq$ 50%

b). Soft start time of VTH setting DUTY $\leq$ 50%

DUTY rises gradually, and rises to Duty=50% temporarily after it starts. The purpose of this is to secure the start torque when DUTY set with VTH and VMIN is too low.

It gradually descends to the DUTY set with VTH and VMIN after it rotates by DUTY=50% for a fixed time.

Fig.95 shows the soft start operation at VTH setting DUTY=10% and VMIN setting DUTY=20%.

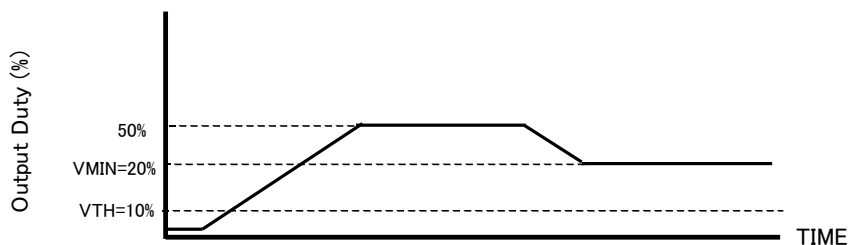

Fig.95 Soft start time chart of DUTY $\leq$ 50%

Because the lock protection function is turned off while soft start, soft start time can be set longer than the lock detection time. The soft start function can be turned off by not connecting the capacitor to VMIN terminal.

9) The upside output of pre-driver<BD6718FV, BD6722FS>

High side output of pre-driver (half pre-driver) are constant current open-drain output. Decide the resistance of R1 so that the voltage generated between G-S of external Pch transistor may exceed enough the threshold voltage of the transistor.

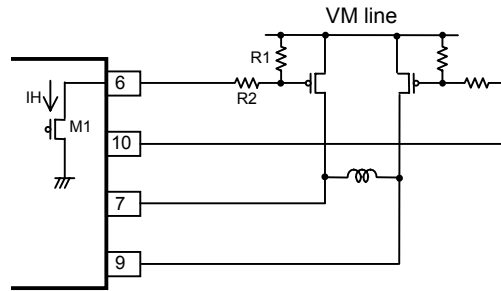

Fig.96 Voltage setting between G-S of external Pch transistor

Ex. At  $R1=100\ \Omega$ ,  $V_{GSP}$  : between G-S of the Pch transistor.

$$\begin{aligned} V_{GSP} &= R1 \times I_H \\ &= 100\ \Omega \times 10\text{mA (typ.)} \\ &= 1\text{V} \end{aligned}$$

\* R2 is used to suppress the power consumption of IC.

At  $V_M = 12\text{V}$ , The power consumption of upside output transistor M1 is

$$P_{M1} = \{ V_M - (R1 + R2) \times I_H \} \times I_H$$

At $R1 = 100\ \Omega$ , $R2 = 0\ \Omega$	$P_{M1}=110\text{mW}$
At $R1 = 100\ \Omega$ , $R2 = 1\text{k}\ \Omega$	$P_{M1}=10\text{mW}$

Especially BD6722FS, useless power consumption in the upside output is suppressed by appropriately setting R2, and a permissible loss of the package can be used effectively in lower output.

●Equivalent circuit

©BD6709FS

1) Hall input terminal

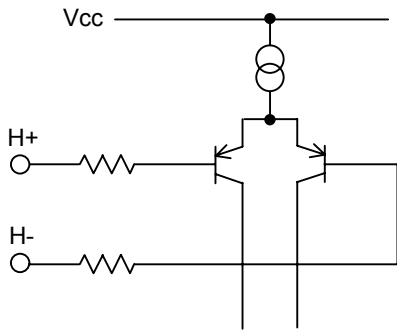

2) Motor output terminal

Output current detecting resistor connecting terminal

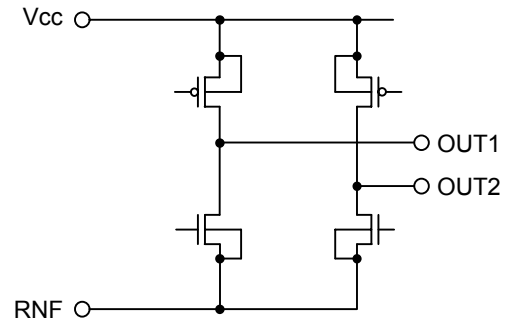

3) Current limiting input

Output current detecting terminal

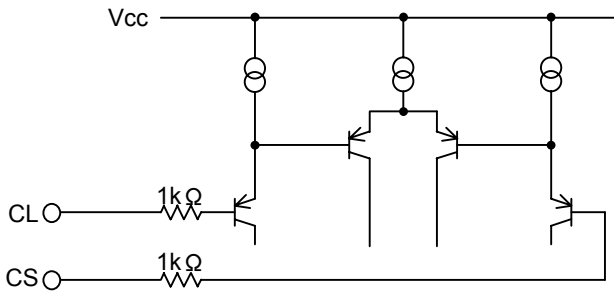

4) FG output terminal

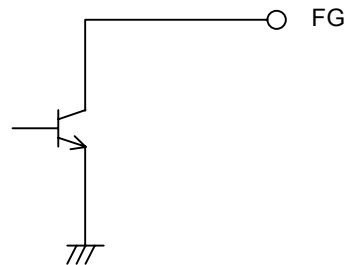

5) Reference voltage terminal

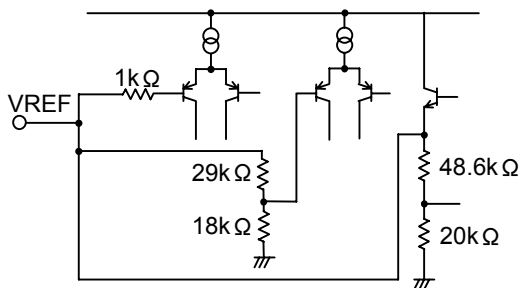

6) Oscillating capacitor connecting terminal

Variable amplifier input terminal

Level amplifier input terminal

Level amplifier output terminal

Minimum rotating speed setting terminal

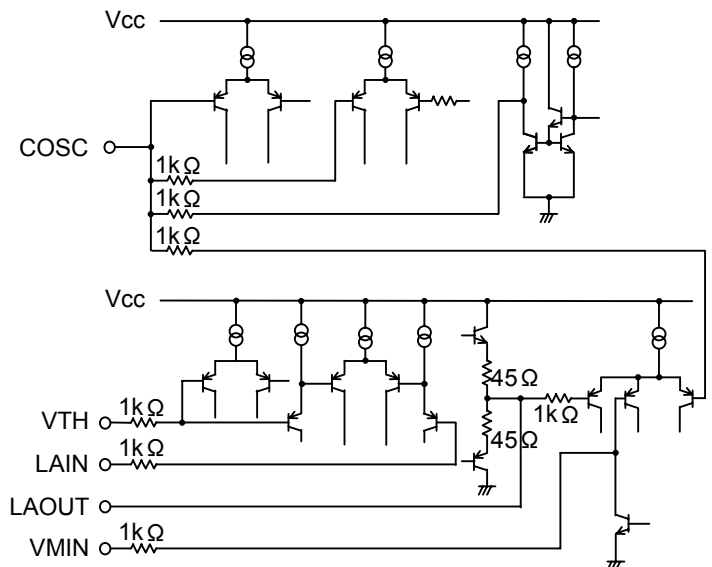

©BD6718FV

1) Hall input terminal

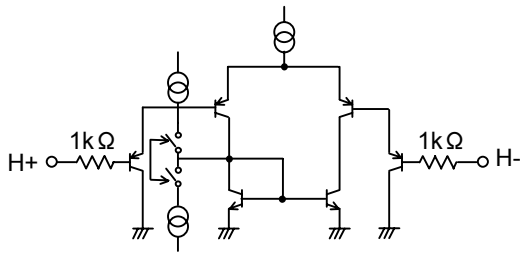

2) Charge and discharge pulse circuit capacitor  
Resistor connecting terminal

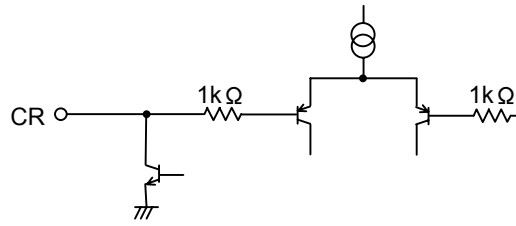

3) Current limiting input terminal  
Output current detecting terminal

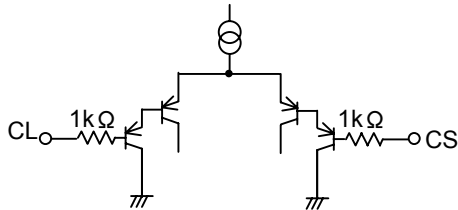

4) Output terminal on H side

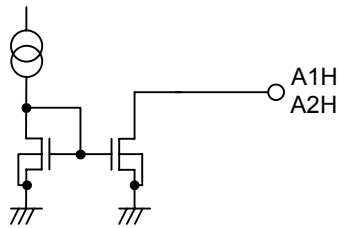

5) Output terminal on L side

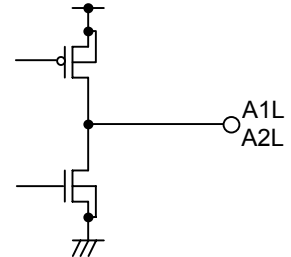

6) Hall bias terminal

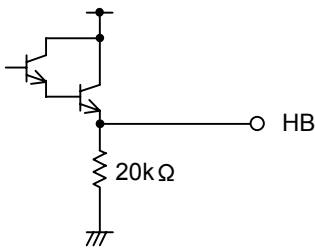

8) Oscillating capacitor connecting terminal  
Variable speed input terminal (thermistor connecting terminal)  
Minimum speed input terminal

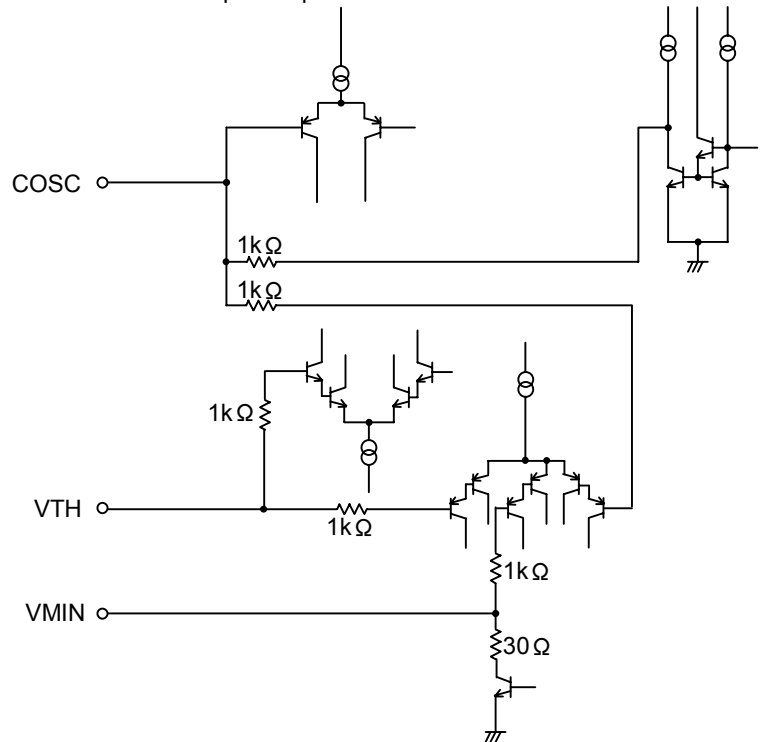

7) Reference voltage terminal

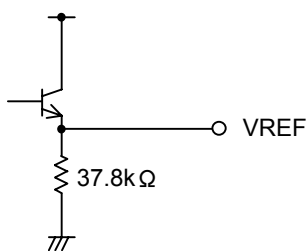

9) Lock detection ON:OFF ratio selecting terminal

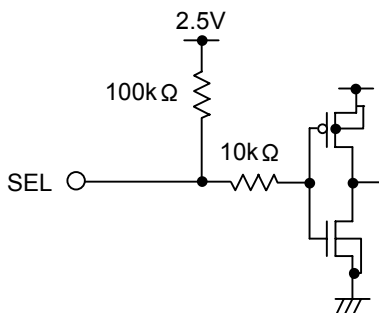

10) FG output terminal or  
AL output terminal

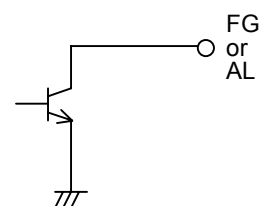

1) Hall input terminal

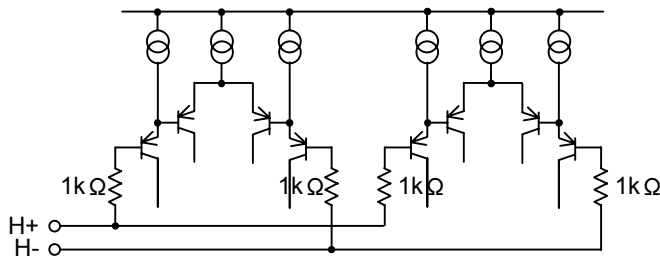

2) Motor output terminal

Output current detecting resistor connecting terminal

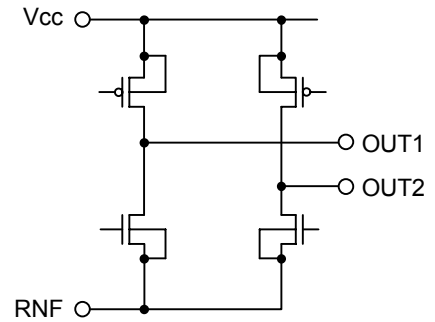

3) Output current detecting terminal

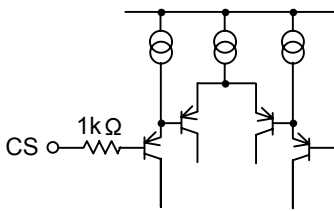

4) FG output terminal or AL output terminal

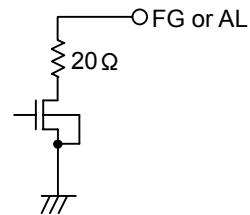

5) Reference voltage terminal

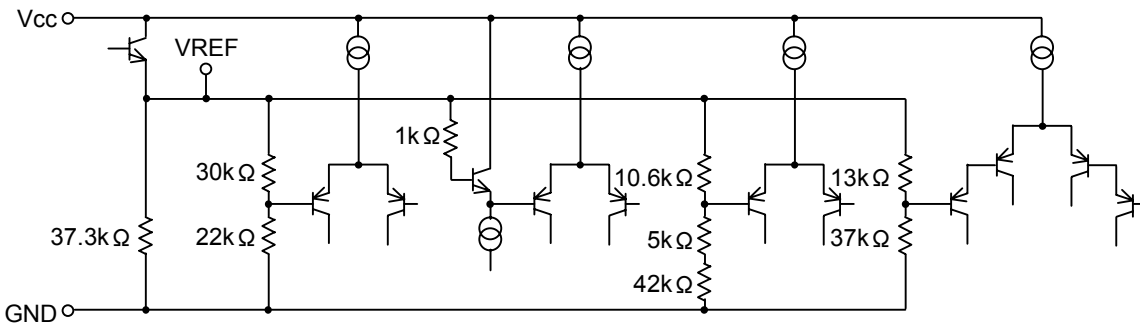

6) Oscillating capacitor connecting terminal

Variable amplifier input terminal (thermistor connecting terminal)

Level amplifier input terminal

Level amplifier output terminal

Minimum rotating speed setting terminal

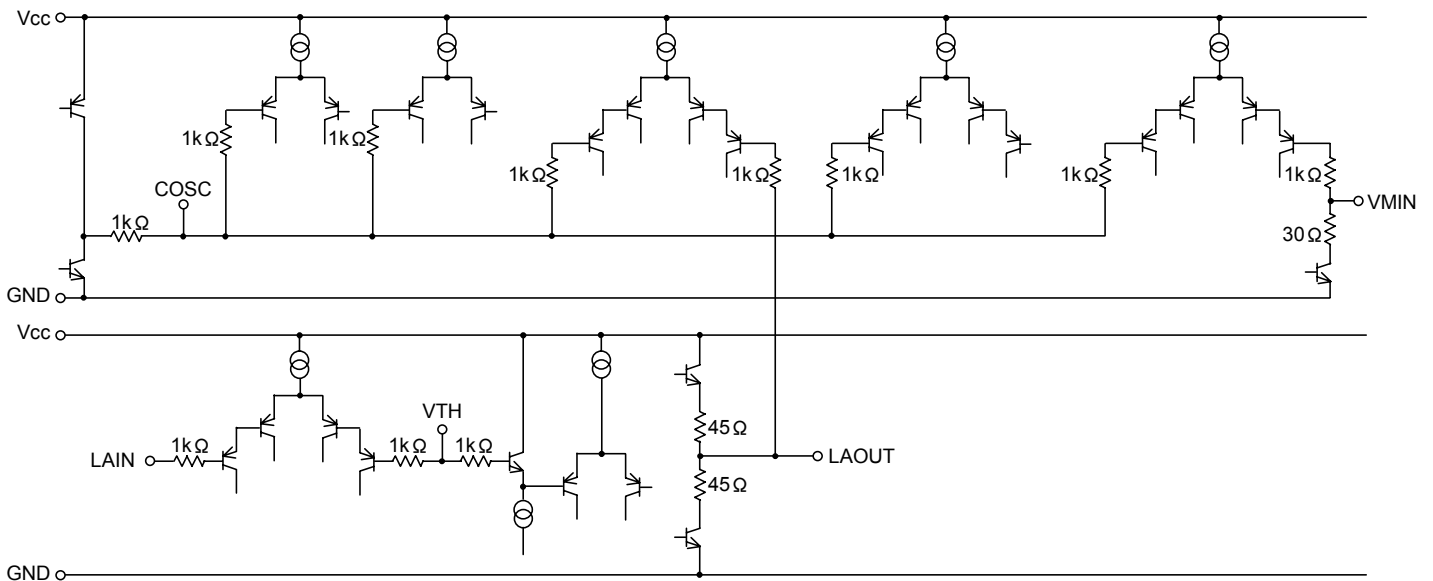

1) Hall input terminal

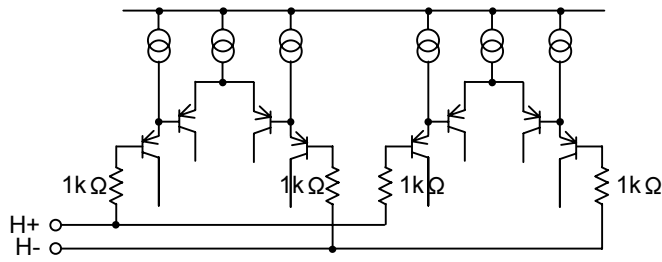

2) Motor output terminal

Output current detecting resistor connecting terminal

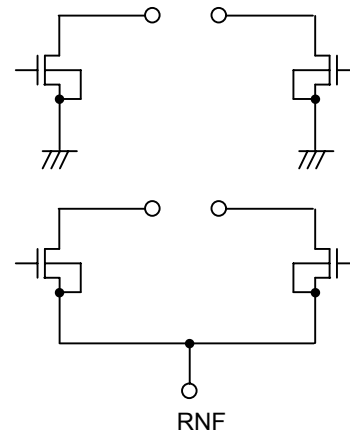

3) Output current detecting terminal

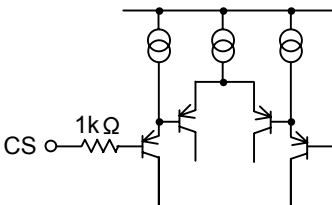

4) FG output terminal or AL output terminal

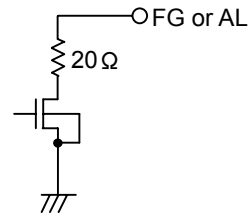

5) Reference voltage terminal

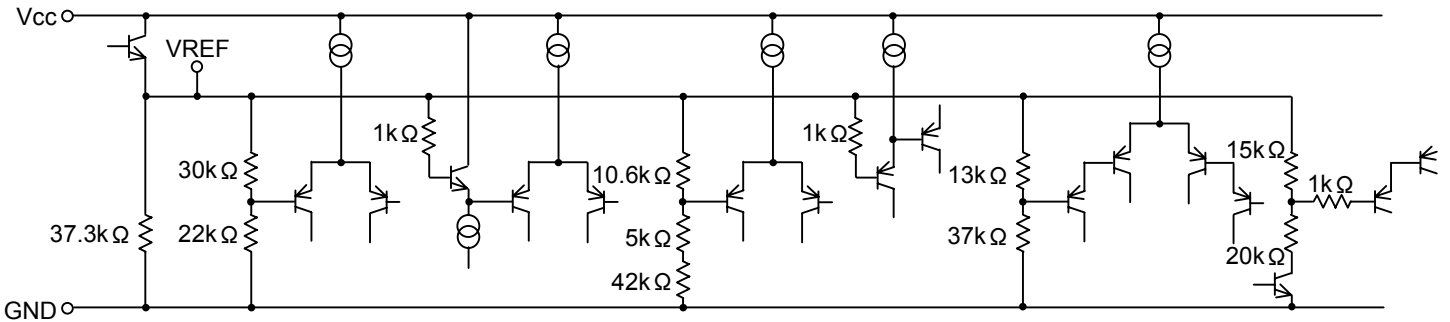

6) Oscillating capacitor connecting terminal

- Variable amplifier input terminal
- Level amplifier input terminal
- Level amplifier output terminal
- Minimum rotating speed setting terminal

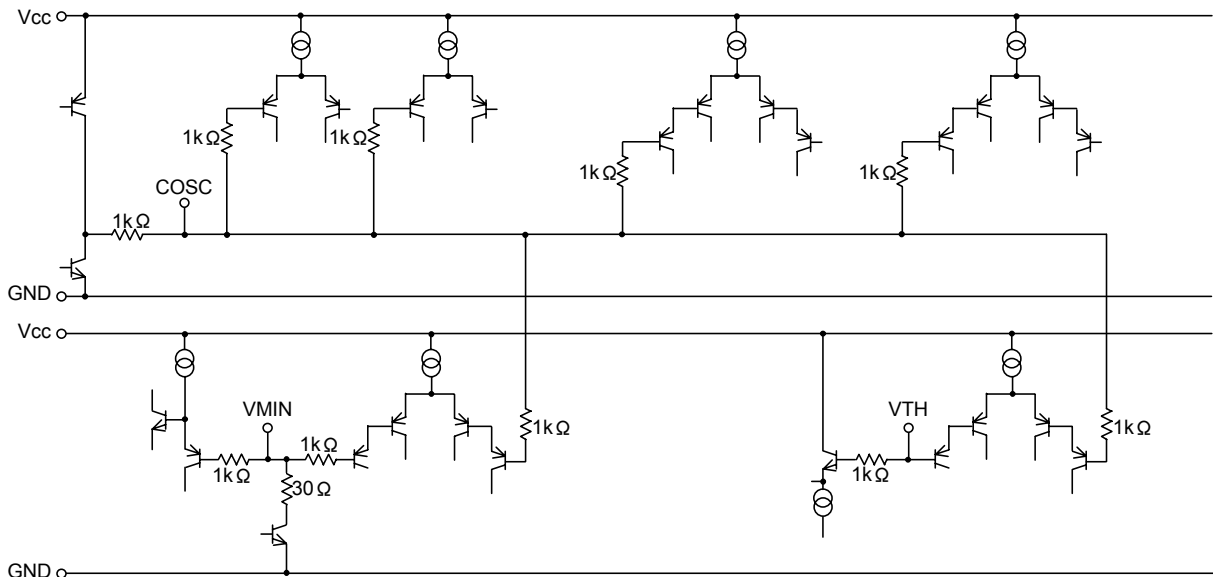

● Safety measure

1) Reverse connection protection diode

Reverse connection of power results in IC destruction as shown in Fig.46. When reverse connection is possible, reverse connection protection diode must be added between power supply and Vcc.

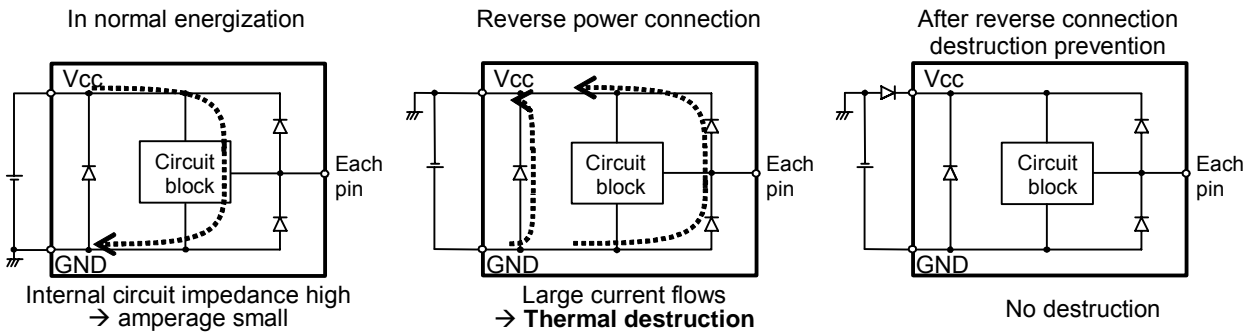

Fig.97 Flow of current when power is connected reversely

2) Measure against Vcc voltage rise by back electromotive force

Back electromotive force (Back EMF) generates regenerative current to power supply. However, when reverse connection protection diode is connected, Vcc voltage rises because the diode prevents current flow to power supply.

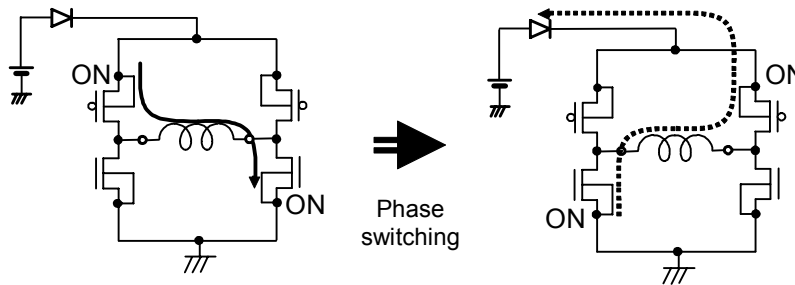

Fig.98 Vcc voltage rise by back electromotive force

When the absolute maximum rated voltage may be exceeded due to voltage rise by back electromotive force, place (A) Capacitor or (B) Zener diode between Vcc and GND. If necessary, add both (C).

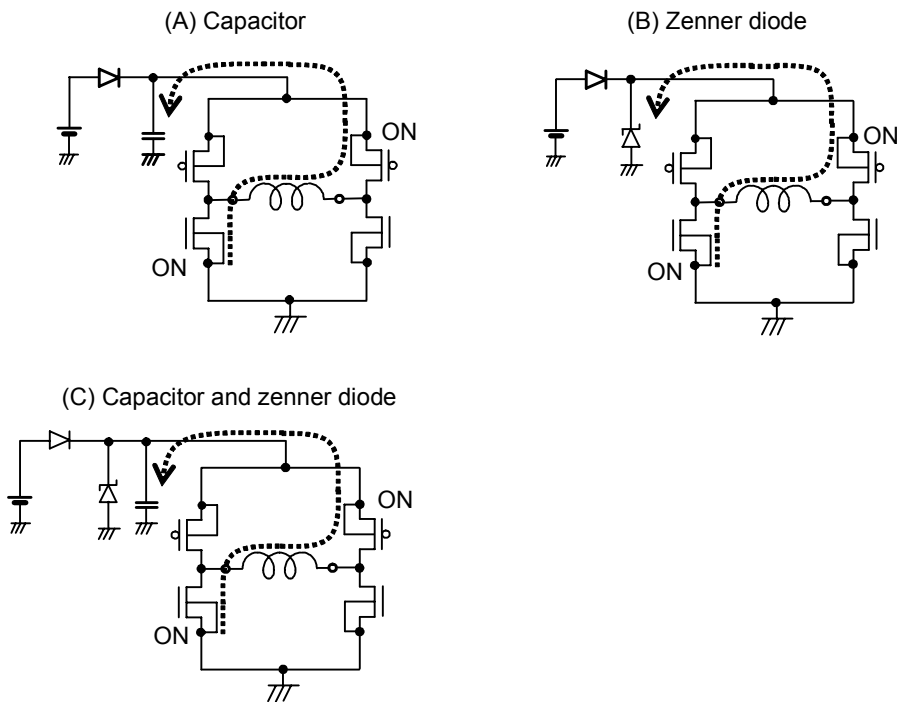

Fig.99 Measure against Vcc voltage rise

3) Problem of GND line PWM switching

Do not perform PWM switching of GND line because GND terminal potential cannot be kept to a minimum.

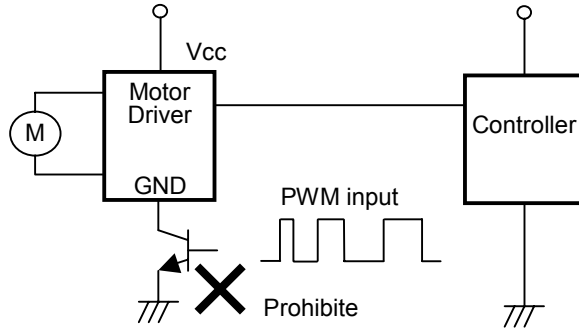

Fig.100 GND line PWM switching prohibited

4) FG and AL output

FG and AL output is an open collector and requires pull-up resistor.

The IC can be protected by adding resistor R1. An excess of absolute maximum rating, when FG or AL output terminal is directly connected to power supply, could damage the IC.

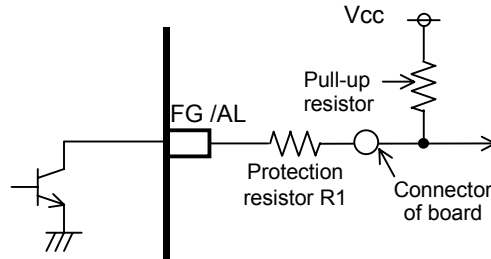

Fig.101 Protection of FG and AL terminal

● Calculation of power consumed by IC

Power consumed by this IC  $P_c$  is approximately calculated as follows:

$$P_c = P_{c1} + P_{c2} + P_{c3}$$

- $P_{c1}$  : Power consumption by circuit current  
 $P_{c1} = V_{cc} \times I_{cc}$
- $P_{c2}$  : Power consumption at output stage  
 $P_{c2} = V_{OL} \times I_o + V_{OH} \times I_o$   
 $V_{OL}$  is L voltage of output terminal 1 and 2.  
 $V_{OH}$  is H voltage of output terminal 1 and 2.  
 $I_o$  is the current flowing to output terminal 1 and 2.
- $P_{c3}$  : Power consumption at FG and AL  
 $P_{c3} = V_{FG} \times I_{FG} + V_{AL} \times I_{AL}$   
 $V_{FG}$  is L voltage of FG output.  
 $V_{AL}$  is L voltage of AL output.  
 $I_{FG}$  and  $I_{AL}$  are the current of FG and AL.

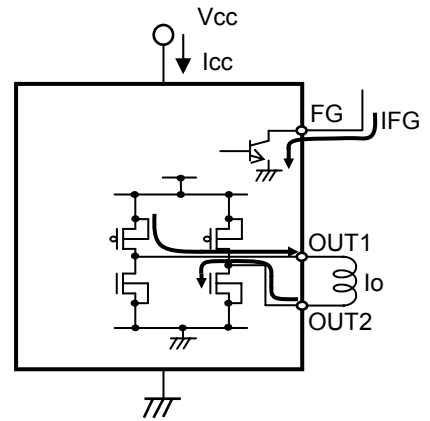

Fig.102 Calculation of power consumed by

Power consumption by IC greatly changes with use condition of IC such as power supply voltage and output current. Consider thermal design so that the maximum power dissipation on IC package is not exceeded.

● Thermal derating curve

Power dissipation (total loss) indicates the power that can be consumed by IC at Ta = 25°C (normal temperature). IC is heated when it consumes power, and the temperature of IC chip becomes higher than ambient temperature. The temperature that can be accepted by IC chip depends on circuit configuration, manufacturing process, etc, and consumable power is limited. Power dissipation is determined by the temperature allowed in IC chip (maximum junction temperature) and thermal resistance of package (heat dissipation capability). The maximum junction temperature is in general equal to the maximum value in the storage temperature range.

Heat generated by consumed power of IC is radiated from the mold resin or lead frame of package. The parameter which indicates this heat dissipation capability (hardness of heat release) is called heat resistance, represented by the symbol  $\theta_{ja}$  [°C/W]. The temperature of IC inside the package can be estimated by this heat resistance. Fig.37 shows the model of heat resistance of the package.

Heat resistance  $\theta_{ja}$ , ambient temperature Ta, junction temperature Tj, and power consumption P can be calculated by the equation below:

$$\theta_{ja} = (T_j - T_a) / P \quad [^{\circ}\text{C}/\text{W}]$$

Thermal derating curve indicates power that can be consumed by IC with reference to ambient temperature. Power that can be consumed by IC begins to attenuate at certain ambient temperature. This gradient is determined by thermal resistance  $\theta_{ja}$ .

Thermal resistance  $\theta_{ja}$  depends on chip size, power consumption, package ambient temperature, packaging condition, wind velocity, etc., even when the same package is used. Thermal derating curve indicates a reference value measured at a specified condition. Fig.38 shows a thermal derating curve (Value when mounting FR4 glass epoxy board 70 [mm] x 70 [mm] x 1.6 [mm] (copper foil area below 3 [%]))

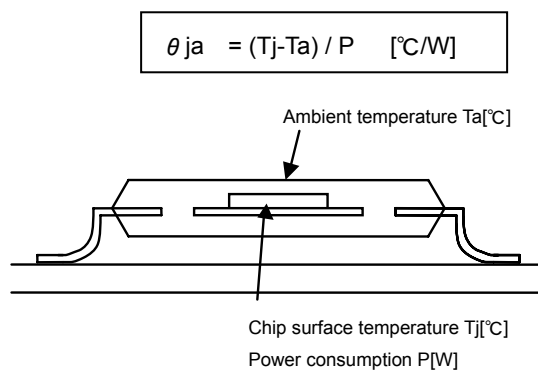
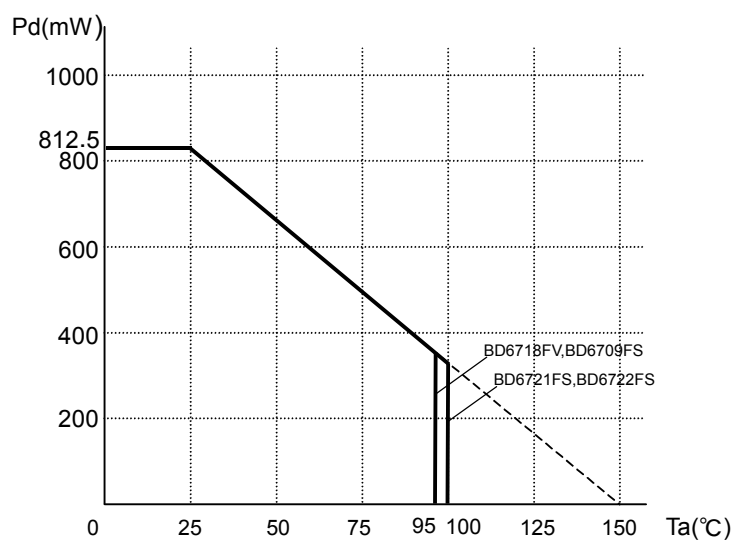

Fig.103 Thermal resistance



\* Reduce by 6.5mW/°C over 25°C.  
 (On 70.0mm x 70.0mm x 1.6mm glass epoxy board)

Fig.104 Thermal derating curve

## ● Cautions on use

### 1) Absolute maximum ratings

An excess in the absolute maximum ratings, such as supply voltage, temperature range of operating conditions, etc., can break down the devices, thus making impossible to identify breaking mode, such as a short circuit or an open circuit. If any over rated values will expect to exceed the absolute maximum ratings, consider adding circuit protection devices, such as fuses.

### 2) Connecting the power supply connector backward

Connecting of the power supply in reverse polarity can damage IC. Take precautions when connecting the power supply lines. An external direction diode can be added.

### 3) Power supply line

Back electromotive force causes regenerated current to power supply line, therefore take a measure such as placing a capacitor between power supply and GND for routing regenerated current. And fully ensure that the capacitor characteristics have no problem before determine a capacitor value. (when applying electrolytic capacitors, capacitance characteristic values are reduced at low temperatures)

### 4) GND potential

The potential of GND pin must be minimum potential in all operating conditions. Also ensure that all terminals except GND terminal do not fall below GND voltage including transient characteristics. However, it is possible that the motor output terminal may deflect below GND because of influence by back electromotive force of motor. Malfunction may possibly occur depending on use condition, environment, and property of individual motor. Please make fully confirmation that no problem is found on operation of IC.

### 5) Thermal design

Use a thermal design that allows for a sufficient margin in light of the power dissipation(Pd) in actual operating conditions.

### 6) Inter-pin shorts and mounting errors

Use caution when positioning the IC for mounting on printed circuit boards. The IC may be damaged if there is any connection error or if pins are shorted together.

### 7) Actions in strong electromagnetic field

Use caution when using the IC in the presence of a strong electromagnetic field as doing so may cause the IC to malfunction.

### 8) ASO

When using the IC, set the output transistor so that it does not exceed absolute maximum ratings or ASO.

### 9) Thermal shut down circuit

The IC incorporates a built-in thermal shutdown circuit (TSD circuit). Operation temperature is 175°C(typ.) and has a hysteresis width of 25°C(typ.). When IC chip temperature rises and TSD circuit works, the output terminal becomes an open state. TSD circuit is designed only to shut the IC off to prevent thermal runaway. It is not designed to protect the IC or guarantee its operation. Do not continue to use the IC after operation this circuit or use the IC in an environment where the operation of this circuit is assumed.

### 10) Testing on application boards

When testing the IC on an application board, connecting a capacitor to a pin with low impedance subjects the IC to stress. Always discharge capacitors after each process or step. Always turn the IC's power supply off before connecting it to or removing it from a jig or fixture during the inspection process. Ground the IC during assembly steps as an antistatic measure. Use similar precaution when transporting or storing the IC.

### 11) GND wiring pattern

When using both small signal and large current GND patterns, it is recommended to isolate the two ground patterns, placing a single ground point at the ground potential of application so that the pattern wiring resistance and voltage variations caused by large currents do not cause variations in the small signal ground voltage. Be careful not to change the GND wiring pattern of any external components, either.

### 12) Capacitor between output and GND

When a large capacitor is connected between output and GND, if Vcc is shorted with 0V or GND for some cause, it is possible that the current charged in the capacitor may flow into the output resulting in destruction. Keep the capacitor between output and GND below 100uF.

### 13) IC terminal input

When Vcc voltage is not applied to IC, do not apply voltage to each input terminal. When voltage above Vcc or below GND is applied to the input terminal, parasitic element is actuated due to the structure of IC. Operation of parasitic element causes mutual interference between circuits, resulting in malfunction as well as destruction in the last. Do not use in a manner where parasitic element is actuated.

### 14) In use

We are sure that the example of application circuit is preferable, but please check the character further more in application to a part which requires high precision. In using the unit with external circuit constant changed, consider the variation of externally equipped parts and our IC including not only static character but also transient character and allow sufficient margin in determining.

● Ordering part number

• Please order by ordering part number. • Please confirm the combination of each items. • Please write the letter close to left when column is blank.

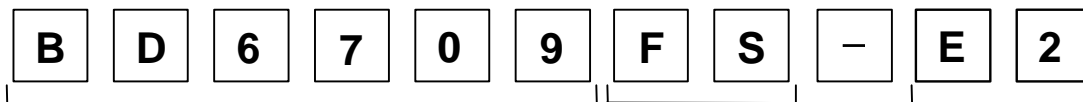

**Part Number**  
 • BD6709    • BD6718  
 • BD6721    • BD6722

**Package Type**  
 • FS : SSOP-A16  
 • FV : SSOP-B20

**Package specification**  
 E2 Emboss tape reel Pin 1 opposite draw-out side

● Physical dimension

**SSOP-A16**

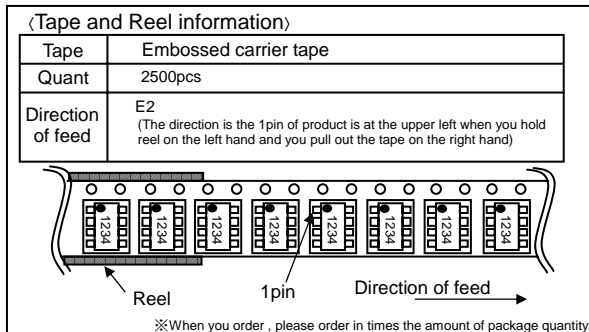
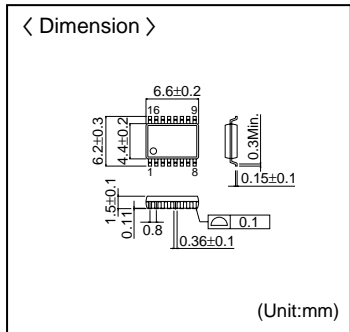

**SSOP-B20**

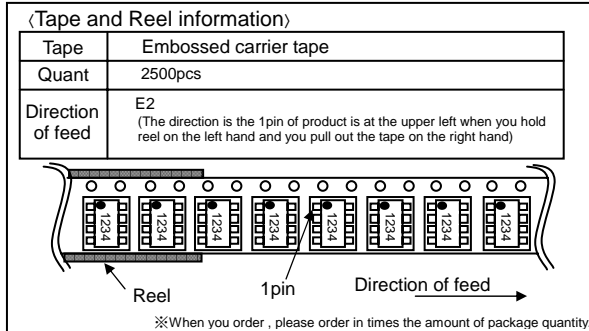
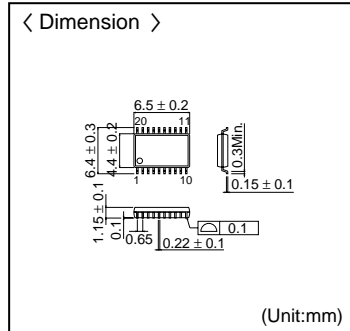

- The contents described herein are correct as of January, 2007
- The contents described herein are subject to change without notice. For updates of the latest information, please contact and confirm with ROHM CO.,LTD.
- Any part of this application note must not be duplicated or copied without our permission.
- Application circuit diagrams and circuit constants contained herein are shown as examples of standard use and operation. Please pay careful attention to the peripheral conditions when designing circuits and deciding upon circuit constants in the set.
- Any data, including, but not limited to application circuit diagrams and information, described herein are intended only as illustrations of such devices and not as the specifications for such devices. ROHM CO.,LTD. disclaims any warranty that any use of such devices shall be free from infringement of any third party's intellectual property rights or other proprietary rights, and further, assumes no liability of whatsoever nature in the event of any such infringement, or arising from or connected with or related to the use of such devices.
- Upon the sale of any such devices, other than for buyer's right to use such devices itself, resell or otherwise dispose of the same, implied right or license to practice or commercially exploit any intellectual property rights or other proprietary rights owned or controlled by ROHM CO., LTD. is granted to any such buyer.
- The products described herein utilize silicon as the main material.
- The products described herein are not designed to be X ray proof.

The products listed in this catalog are designed to be used with ordinary electronic equipment or devices (such as audio visual equipment, office-automation equipment, communications devices, electrical appliances and electronic toys). Should you intend to use these products with equipment or devices which require an extremely high level of reliability and the malfunction of which would directly endanger human life (such as medical instruments, transportation equipment, aerospace machinery, nuclear-reactor controllers, fuel controllers and other safety devices), please be sure to consult with our sales representative in advance.

Contact us for further information about the products.

<b>Seoul</b>	TEL: +82-2-8182-700	FAX: +82-2-8182-715	<b>Bangkok</b>	TEL: +66-2-254-4890	FAX: +66-2-256-6334
<b>Masan</b>	TEL: +82-55-240-6234	FAX: +82-55-240-6236	<b>Kuala Lumpur</b>	TEL: +60-3-7958-8355	FAX: +60-3-7958-8377
<b>Dalian</b>	TEL: +86-411-8230-8549	FAX: +86-411-8230-8537	<b>Penang</b>	TEL: +60-4-6585084	FAX: +60-4-6585167
<b>Beijing</b>	TEL: +86-10-8525-2483	FAX: +86-10-8525-2489	<b>Dusseldorf</b>	TEL: +49-2145-9210	FAX: +49-2154-921400
<b>Tianjin</b>	TEL: +86-22-23029181	FAX: +86-22-23029183	<b>Munich</b>	TEL: +49-8161-48310	FAX: +49-8161-483120
<b>Shanghai</b>	TEL: +86-21-6279-2727	FAX: +86-21-6247-2066	<b>Stuttgart</b>	TEL: +49-711-72723710	FAX: +49-711-72723720
<b>Hangzhou</b>	TEL: +86-571-87658072	FAX: +86-571-87658071	<b>France</b>	TEL: +33-1-5697-3060	FAX: +33-1-5697-3080
<b>Nanjing</b>	TEL: +86-25-8689-0015	FAX: +86-25-8689-0393	<b>United Kingdom</b>	TEL: +44-1-908-306700	FAX: +44-1-908-235788
<b>Ningbo</b>	TEL: +86-574-87654201	FAX: +86-574-87654208	<b>Denmark</b>	TEL: +45-3694-4739	FAX: +45-3694-4789
<b>Qingdao</b>	TEL: +86-532-5779-312	FAX: +86-532-5779-653	<b>Barcelona</b>	TEL: +34-9375-24320	FAX: +34-9375-24410
<b>Suzhou</b>	TEL: +86-512-6807-1300	FAX: +86-512-6807-2300	<b>Malaga</b>	TEL: +34-9520-20263	FAX: +34-9520-20023
<b>Tianjin</b>	TEL: +86-22-23029181	FAX: +86-22-23029183	<b>Hungary</b>	TEL: +36-1-4719338	FAX: +36-1-4719339
<b>Wuxi</b>	TEL: +86-510-82702693	FAX: +86-510-82702992	<b>Poland</b>	TEL: +48-22-5757213	FAX: +48-22-5757001
<b>Hong Kong</b>	TEL: +852-2-740-6262	FAX: +852-2-375-8971	<b>Russia</b>	TEL: +7-95-980-6755	FAX: +7-95-937-8290
<b>Dongguan</b>	TEL: +86-769-393-3320	FAX: +86-769-398-4140	<b>San Diego</b>	TEL: +1-858-625-3630	FAX: +1-858-625-3670
<b>Fuzhou</b>	TEL: +86-591-8801-8698	FAX: +86-591-8801-8690	<b>Atlanta</b>	TEL: +1-770-754-5972	FAX: +1-770-754-0691
<b>Guangzhou</b>	TEL: +86-20-8364-9706	FAX: +86-20-8364-9707	<b>Boston</b>	TEL: +1-978-371-0382	FAX: +1-928-438-7164
<b>Shenzhen</b>	TEL: +86-755-8307-3001	FAX: +86-755-8307-3003	<b>Chicago</b>	TEL: +1-847-368-1006	FAX: +1-847-368-1008
<b>Xiamen</b>	TEL: +86-592-239-8382	FAX: +86-592-239-8380	<b>Dallas</b>	TEL: +1-972-312-8818	FAX: +1-972-312-0330
<b>Zhuhai</b>	TEL: +86-756-3232-4600	FAX: +86-756-3232-4600	<b>Denver</b>	TEL: +1-303-708-0908	FAX: +1-303-708-0858
<b>Taipei</b>	TEL: +886-2-2500-6956	FAX: +886-2-2503-2869	<b>Nashville</b>	TEL: +1-615-620-6700	FAX: +1-615-620-6702
<b>Kaohsiung</b>	TEL: +886-7-237-0881	FAX: +886-7-238-7332	<b>Guadalajara</b>	TEL: +52-33-3123-2001	FAX: +52-33-3123-2002
<b>Singapore</b>	TEL: +65-6332-2322	FAX: +65-6332-5662			
<b>Manila</b>	TEL: +63-2-807-6872	FAX: +63-2-809-1422			

Excellence in Electronics



**ROHM CO., LTD.**

21, Saiin Mizosaki-cho, Ukyo-ku, Kyoto  
 615-8585, Japan  
 TEL: +81-75-311-2121 FAX: +81-75-315-0172  
 URL: http://www.rohm.com

Published by  
**LSI Business Promotion Dept.**

### Notes

- No technical content pages of this document may be reproduced in any form or transmitted by any means without prior permission of ROHM CO.,LTD.
- The contents described herein are subject to change without notice. The specifications for the product described in this document are for reference only. Upon actual use, therefore, please request that specifications to be separately delivered.
- Application circuit diagrams and circuit constants contained herein are shown as examples of standard use and operation. Please pay careful attention to the peripheral conditions when designing circuits and deciding upon circuit constants in the set.
- Any data, including, but not limited to application circuit diagrams information, described herein are intended only as illustrations of such devices and not as the specifications for such devices. ROHM CO.,LTD. disclaims any warranty that any use of such devices shall be free from infringement of any third party's intellectual property rights or other proprietary rights, and further, assumes no liability of whatsoever nature in the event of any such infringement, or arising from or connected with or related to the use of such devices.
- Upon the sale of any such devices, other than for buyer's right to use such devices itself, resell or otherwise dispose of the same, no express or implied right or license to practice or commercially exploit any intellectual property rights or other proprietary rights owned or controlled by
- ROHM CO., LTD. is granted to any such buyer.
- Products listed in this document are no antiradiation design.

The products listed in this document are designed to be used with ordinary electronic equipment or devices (such as audio visual equipment, office-automation equipment, communications devices, electrical appliances and electronic toys).

Should you intend to use these products with equipment or devices which require an extremely high level of reliability and the malfunction of which would directly endanger human life (such as medical instruments, transportation equipment, aerospace machinery, nuclear-reactor controllers, fuel controllers and other safety devices), please be sure to consult with our sales representative in advance.

It is our top priority to supply products with the utmost quality and reliability. However, there is always a chance of failure due to unexpected factors. Therefore, please take into account the derating characteristics and allow for sufficient safety features, such as extra margin, anti-flammability, and fail-safe measures when designing in order to prevent possible accidents that may result in bodily harm or fire caused by component failure. ROHM cannot be held responsible for any damages arising from the use of the products under conditions out of the range of the specifications or due to non-compliance with the NOTES specified in this catalog.

Thank you for your accessing to ROHM product informations.

More detail product informations and catalogs are available, please contact your nearest sales office.

**ROHM** Customer Support System



THE AMERICAS / EUROPE / ASIA / JAPAN

[www.rohm.com](http://www.rohm.com)





Contact us : [webmaster@rohm.co.jp](mailto:webmaster@rohm.co.jp)

## Looking for pricing, stock, or lifecycle information?

Click below to explore more details on WIN SOURCE:

-  [View BD6718FV-E2 on WIN SOURCE](#)
-  [Rohm Semiconductor](#) Information

## Optimize Your Supply Chain with WIN SOURCE Solutions

-  Global Sourcing Solution
-  Obsolete Management
-  Cost Control Management
-  Shortage Management
-  Alternative Solution
-  Excess Inventory Management