



THE DATASHEET OF ICPL0501SMT&R





ICPL0452 / ICPL0453 / ICPL0500 / ICPL0501

DESCRIPTION

The ICPL0452, ICPL0453, ICPL0500 and ICPL0501 devices each consist of an infrared emitting diode, optically coupled to a high speed photo detector transistor. A separate connection for the photodiode bias and output-transistor collector increase the speed by several orders of magnitude over conventional phototransistor couplers by reducing the base-collector capacitance of the input transistor.

These devices belong to Isocom Compact Range of optocouplers.

FEATURES

- Half Pitch 1.27mm
- High speed 1Mbit/s
- 15kV/μs min. Common Mode Transient Immunity (ICPL0453)
- High AC Isolation Voltage 3750V_{rms}
- Guaranteed Performance from 0°C to 70°C
- Wide Operating Temperature Range -55°C to 100°C
- Pb Free and RoHS Compliant
- Halogen Free
- Safety Approvals Pending

APPLICATIONS

- Line Receivers
- Telecommunication Equipments
- Power Transistor Isolation in Motor Drives
- Replacement of Low Speed Phototransistor Optocouplers
- Feedback Loop in Switch Mode Power Supplies
- High Speed Logic Ground Isolation
- Home Appliances

ORDER INFORMATION

- Add T&R after PN for Surface Mount Tape & Reel

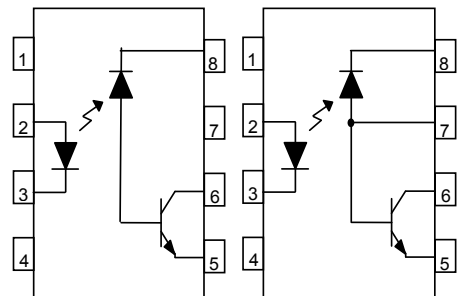

ICPL0452 / ICPL0453

ICPL0500 / ICPL0501

1. NC
2. Anode
3. Cathode
4. NC
5. Gnd
6. Vout
7. VB
(ICPL0500/
ICPL0501)
8. Vcc
(ICPL0452/
ICPL0453)

ABSOLUTE MAXIMUM RATINGS (T_A = 25°C)

Input Diode

Forward Current	25mA
Peak Forward Current (50% duty cycle, 1ms pulse width)	50mA
Peak Transient Current (≤1μs pulse width, 300pps)	1A
Reverse Voltage	5V
Power dissipation	45mW

Output

Output Current	8mA
Peak Output Current	16mA
Emitter-Base Reverse Voltage (ICPL0500 and ICPL0501 only)	5V
Base Current (ICPL0500 and ICPL0501 only)	5mA
Output Voltage	-0.5 to 20V
Supply Voltage	-0.5 to 30V
Power Dissipation	100mW

Total Package

Isolation Voltage	3750V _{rms}
Operating Temperature	-55 to 100 °C
Storage Temperature	-55 to 125 °C
Lead Soldering Temperature (10s)	260°C

ISOCOM COMPONENTS 2004 LTD

Unit 25B, Park View Road West, Park View Industrial Estate
Hartlepool, Cleveland, TS25 1UD, United Kingdom
Tel: +44 (0)1429 863 609 Fax : +44 (0)1429 863 581
e-mail: sales@isocom.co.uk
<http://www.isocom.com>

ISOCOM COMPONENTS ASIA LTD

Hong Kong Office,
Block A, 8/F, Wah Hing Industrial mansion,
36 Tai Yau Street, San Po Kong, Kowloon, Hong Kong.
Tel: +852 2995 9217 Fax : +852 8161 6292
e-mail sales@isocom.com.hk



ICPL0452 / ICPL0453 / ICPL0500 / ICPL0501

ELECTRICAL CHARACTERISTICS ($T_A = 0^\circ\text{C}$ to 70°C unless otherwise specified)

INPUT

Parameter	Symbol	Test Condition	Min	Typ.*	Max	Unit
Forward Voltage	V_F	$I_F = 16\text{mA}$		1.5	1.8	V
Reverse Voltage	V_R	$I_R = 10\mu\text{A}$	5.0			V
Temperature Coefficient of V_F	$\Delta V_F / \Delta T_A$	$I_F = 16\text{mA}$		-1.6		mV/ $^\circ\text{C}$

OUTPUT

Parameter	Symbol	Test Condition	Min	Typ.*	Max	Unit
Logic High Output Current	I_{OH}	$I_F = 0\text{mA}, V_O = V_{CC} = 5.5\text{V}, T_A = 25^\circ\text{C}$		0.001	0.5	μA
		$I_F = 0\text{mA}, V_O = V_{CC} = 15\text{V}, T_A = 25^\circ\text{C}$		0.01	1	
		$I_F = 0\text{mA}, V_O = V_{CC} = 15\text{V}$			50	
Logic Low Supply Current	I_{CCL}	$I_F = 16\text{mA}, V_O = \text{Open}, V_{CC} = 15\text{V}$		140	200	μA
Logic High Supply Current	I_{CCH}	$I_F = 0\text{mA}, V_O = \text{Open}, V_{CC} = 15\text{V}, T_A = 25^\circ\text{C}$		0.01	1	μA
		$I_F = 0\text{mA}, V_O = \text{Open}, V_{CC} = 15\text{V}$			2	

* Typical values at $T_A = 25^\circ\text{C}$



ICPL0452 / ICPL0453 / ICPL0500 / ICPL0501

ELECTRICAL CHARACTERISTICS ($T_A = 0^\circ\text{C}$ to 70°C unless otherwise specified)

COUPLED

Parameter	Symbol	Test Condition	Min	Typ.*	Max	Unit
Current Transfer Ratio	CTR	ICPL0500 ICPL0452/ ICPL0453 / ICPL0501 $I_F = 16\text{mA}$, $V_O = 0.4\text{V}$ $V_{CC} = 4.5\text{V}$, $T_A = 25^\circ\text{C}$	7 19		50 50	%
		ICPL0500 ICPL0452/ ICPL0453 / ICPL0501 $I_F = 16\text{mA}$, $V_O = 0.5\text{V}$ $V_{CC} = 4.5\text{V}$	5 15			
Logic Low Output Voltage	V_{OL}	ICPL0500 $I_F = 16\text{mA}$, $I_O = 1.1\text{mA}$, $V_{CC} = 4.5\text{V}$, $T_A = 25^\circ\text{C}$		0.18	0.4	V
		ICPL0452/ ICPL0453 / ICPL0501 $I_F = 16\text{mA}$, $I_O = 3\text{mA}$, $V_{CC} = 4.5\text{V}$, $T_A = 25^\circ\text{C}$		0.18	0.4	
		ICPL0500 $I_F = 16\text{mA}$, $I_O = 0.8\text{mA}$, $V_{CC} = 4.5\text{V}$			0.5	
		ICPL0452/ ICPL0453 / ICPL0501 $I_F = 16\text{mA}$, $I_O = 2.4\text{mA}$, $V_{CC} = 4.5\text{V}$			0.5	

* Typical values at $T_A = 25^\circ\text{C}$



ICPL0452 / ICPL0453 / ICPL0500 / ICPL0501

ELECTRICAL CHARACTERISTICS ($T_A = 0^\circ\text{C}$ to 70°C unless otherwise specified)

Switching Characteristics ($T_A = 0^\circ\text{C}$ to 70°C , $I_F = 16\text{mA}$, $V_{CC} = 5\text{V}$ unless otherwise specified)

Parameter	Symbol	Test Condition	Min	Typ.*	Max	Unit
Propagation Delay Time to Logic Low	T_{PHL}	ICPL0500 $R_L = 4.1\text{k}\Omega$, $T_A = 25^\circ\text{C}$ $R_L = 4.1\text{k}\Omega$			1.5 2.0	μs
		ICPL0452/ ICPL0453 / ICPL0501 $R_L = 1.9\text{k}\Omega$, $T_A = 25^\circ\text{C}$ $R_L = 1.9\text{k}\Omega$			0.8 1.0	
Propagation Delay Time to Logic High	T_{PLH}	ICPL0500 $R_L = 4.1\text{k}\Omega$, $T_A = 25^\circ\text{C}$ $R_L = 4.1\text{k}\Omega$			1.5 2.0	μs
		ICPL0452/ ICPL0453 / ICPL0501 $R_L = 1.9\text{k}\Omega$, $T_A = 25^\circ\text{C}$ $R_L = 1.9\text{k}\Omega$			0.8 1.0	
Common Mode Transient Immunity at Logic High	CM_H	ICPL0500 $I_F = 0\text{mA}$, $V_{CM} = 10\text{Vp-p}$, $R_L = 4.1\text{k}\Omega$, $T_A = 25^\circ\text{C}$		1000		$\text{V}/\mu\text{s}$
		ICPL0452/ ICPL0501 $I_F = 0\text{mA}$, $V_{CM} = 10\text{Vp-p}$, $R_L = 1.9\text{k}\Omega$, $T_A = 25^\circ\text{C}$		1000		
		ICPL0453 $I_F = 0\text{mA}$, $V_{CM} = 1500\text{Vp-p}$, $R_L = 1.9\text{k}\Omega$, $T_A = 25^\circ\text{C}$	15000			
Common Mode Transient Immunity at Logic Low	CM_L	ICPL0500 $I_F = 16\text{mA}$, $V_{CM} = 10\text{Vp-p}$, $R_L = 4.1\text{k}\Omega$, $T_A = 25^\circ\text{C}$		1000		$\text{V}/\mu\text{s}$
		ICPL0452/ ICPL0501 $I_F = 16\text{mA}$, $V_{CM} = 10\text{Vp-p}$, $R_L = 1.9\text{k}\Omega$, $T_A = 25^\circ\text{C}$		1000		
		ICPL0453 $I_F = 16\text{mA}$, $V_{CM} = 1500\text{Vp-p}$, $R_L = 1.9\text{k}\Omega$, $T_A = 25^\circ\text{C}$	15000			

* Typical values at $T_A = 25^\circ\text{C}$



ICPL0452 / ICPL0453 / ICPL0500 / ICPL0501

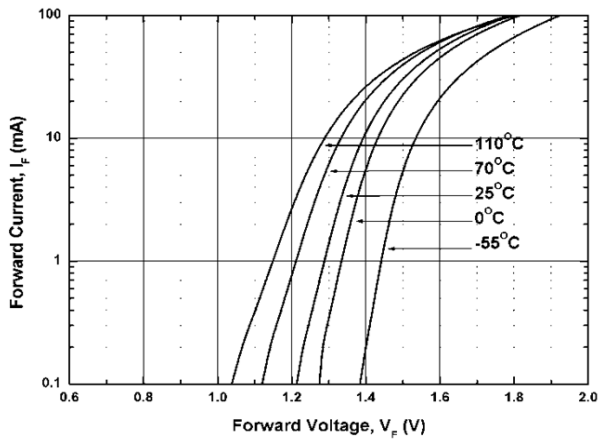

Fig 1 Forward Current vs Forward Voltage

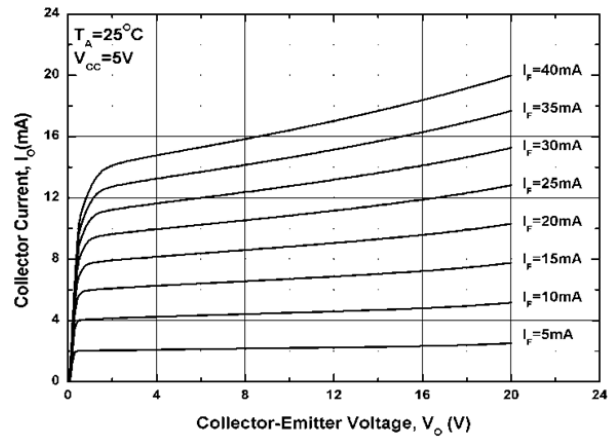

Fig 2 Output Current vs Output Voltage

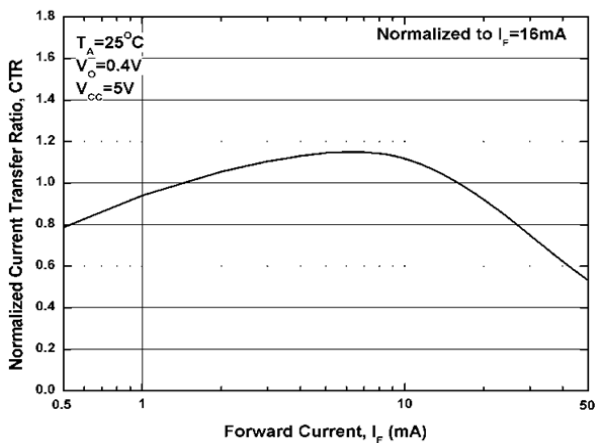

Fig 3 Normalized CTR vs Forward Current

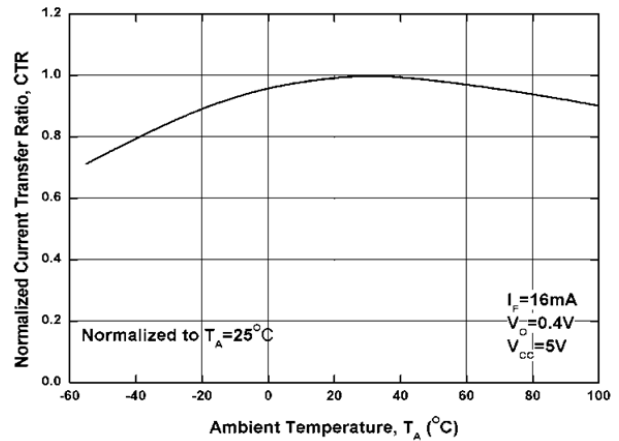

Fig 4 Normalized CTR vs T_A

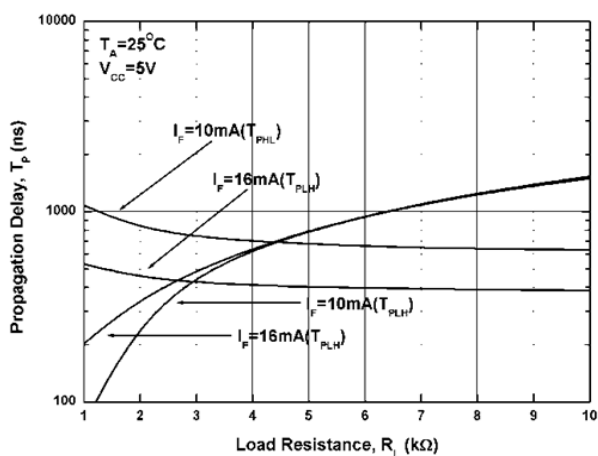

Fig 5 Propagation Delay vs Load Resistance

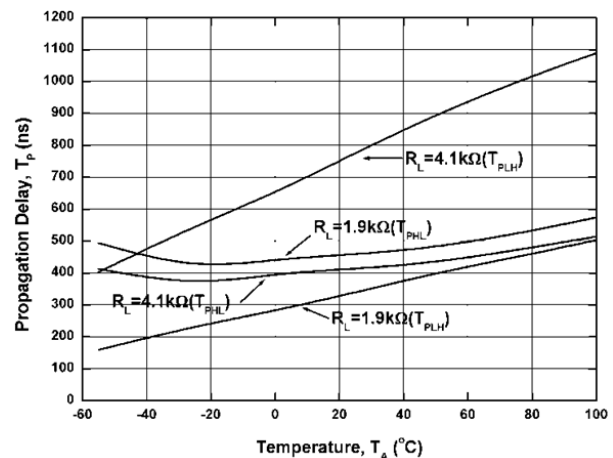

Fig 6 Propagation Delay vs T_A



ICPL0452 / ICPL0453 / ICPL0500 / ICPL0501

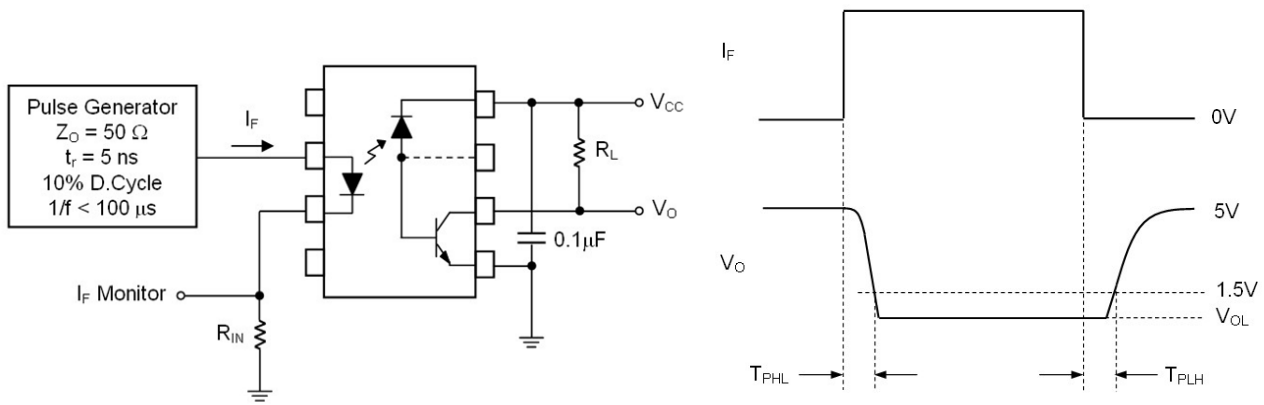

Fig 7 Switching Time Test Circuit

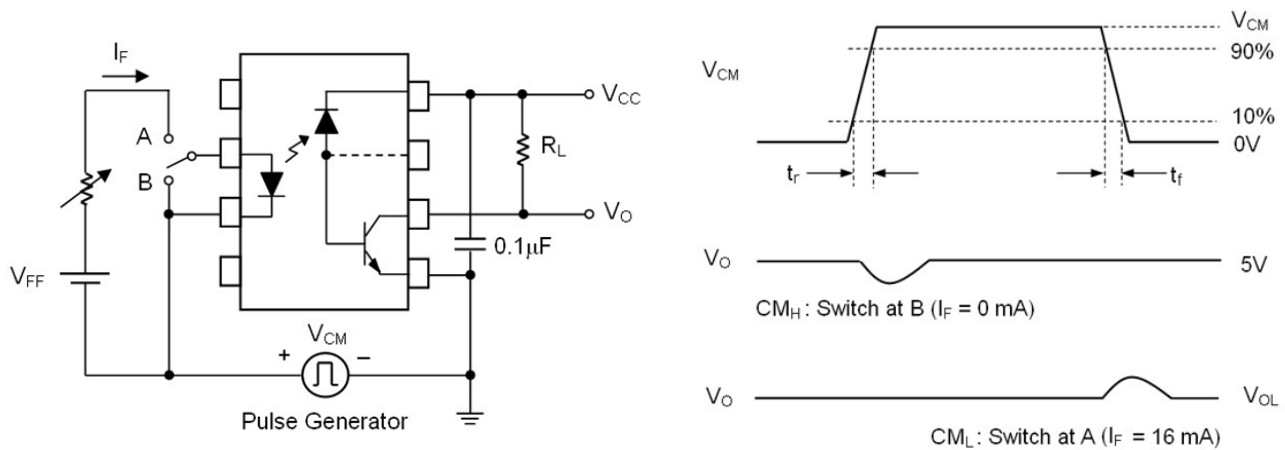

Fig 8 Common Mode Transient Immunity Test Circuit

Note:

Common mode transient immunity in logic high level is the maximum tolerable (positive) dV_{CM}/dt on the leading edge of the common mode pulse signal V_{CM} , to assure that the output will remain in a logic high state (i.e., $V_O > 2.0V$).

Common mode transient immunity in logic low level is the maximum tolerable (negative) dV_{CM}/dt on the trailing edge of the common mode pulse signal, V_{CM} , to assure that the output will remain in a logic low state (i.e., $V_O < 0.8V$).



ICPL0452 / ICPL0453 / ICPL0500 / ICPL0501

PACKAGE DIMENSIONS (mm)

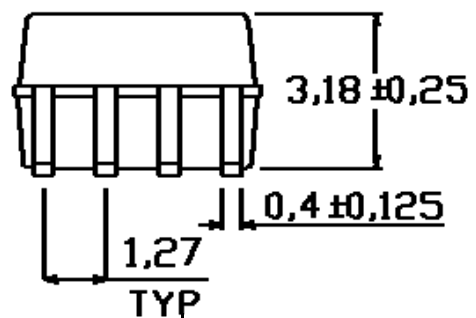
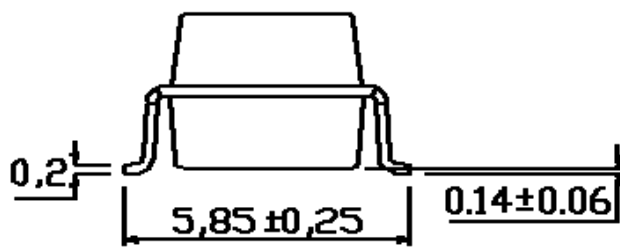
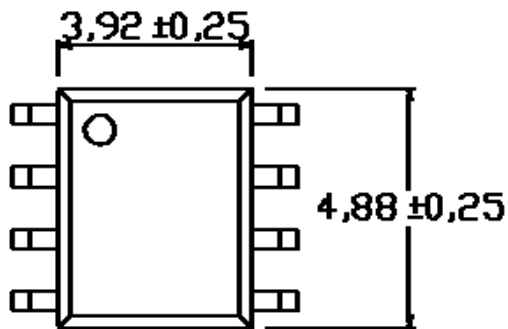

Recommended Pad Layout

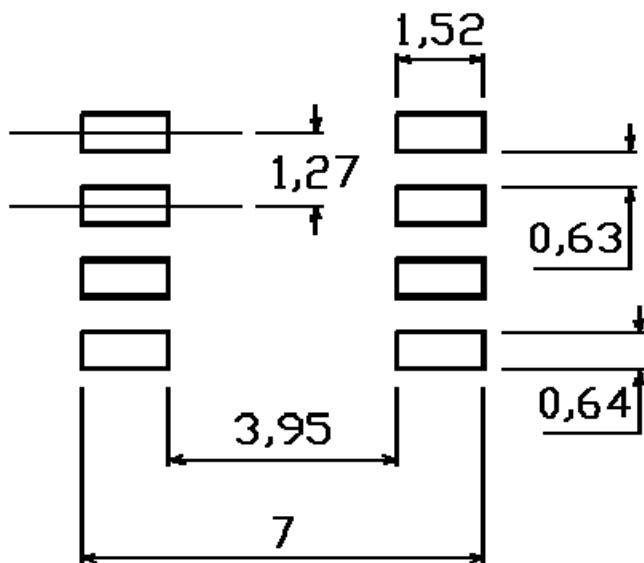



ICPL0452 / ICPL0453 / ICPL0500 / ICPL0501

Device Marking (Example ICPL0452)

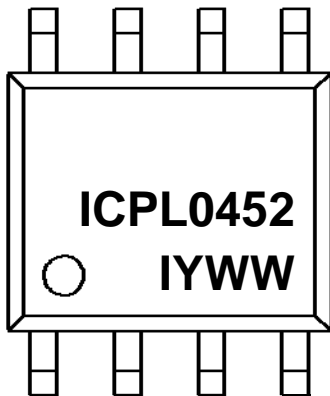

ICPL0452 denotes Device Part Number
Y denotes 1 digit Year code
WW denotes 2 digit Week code
I denotes Isocom

REFLOW SOLDERING TEMPERATURE PROFILE

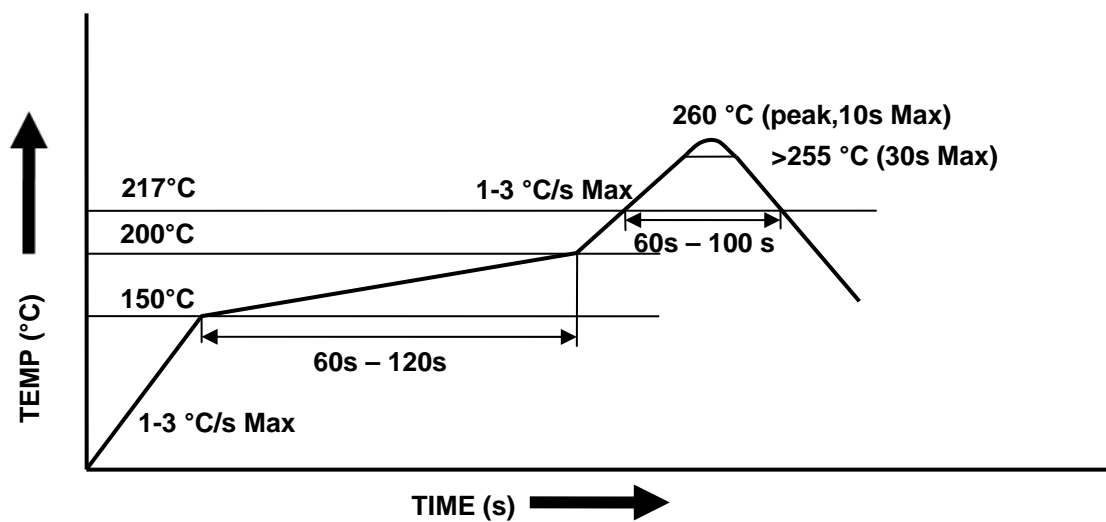



ICPL0452 / ICPL0453 / ICPL0500 / ICPL0501

Tape and Reel Packaging

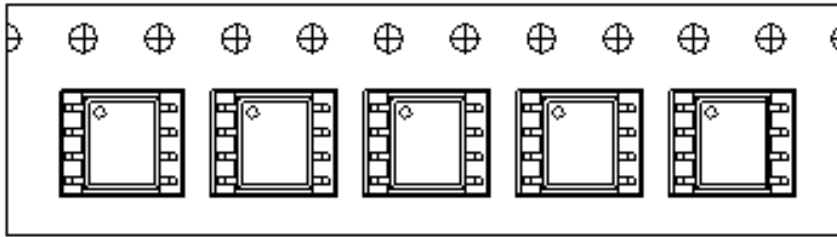

Direction of feed from reel

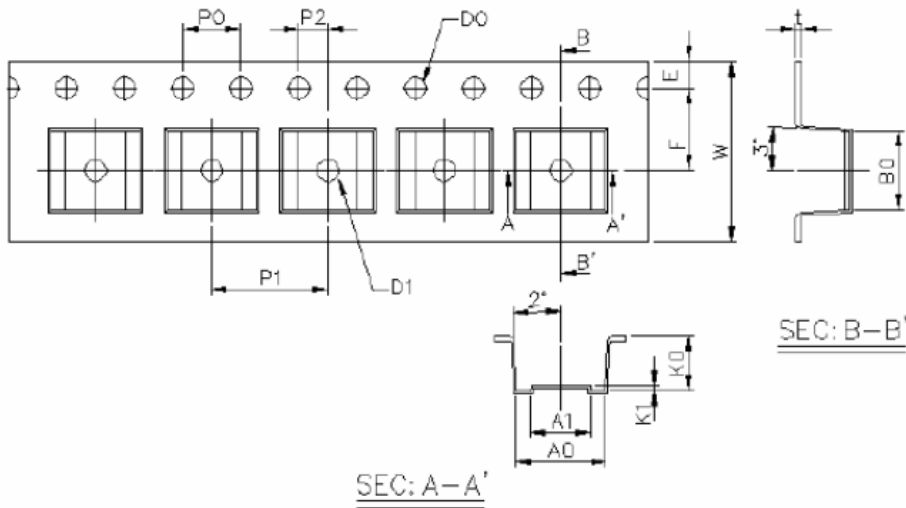

Dimension No.	A0	A1	B0	D0	D1	E	F
Dimension (mm)	6.2±0.1	4.1±0.1	5.28±0.1	1.5±0.1	1.5±0.3	1.75±0.1	5.5±0.1
Dimension No.	Po	P1	P2	t	W	K0	K1
Dimension (mm)	4.0±0.1	8.0±0.1	2.0±0.1	0.4±0.1	12.0 +0.3/-0.1	3.7±0.1	0.3±0.1

Looking for pricing, stock, or lifecycle information?

Click below to explore more details on WIN SOURCE:

-  [View ICPL0501SMT&R on WIN SOURCE](#)
-  [Isocom Components 2004 LTD Information](#)

Optimize Your Supply Chain with WIN SOURCE Solutions

-  Global Sourcing Solution
-  Obsolete Management
-  Cost Control Management
-  Shortage Management
-  Alternative Solution
-  Excess Inventory Management