



**THE DATASHEET OF  
ICE3AR4780JGXUMA1**





**Table of Contents**

**1 Pin Configuration and Functionality ..... 3**

**2 Representative Block Diagram ..... 4**

**3 Functional Description ..... 5**

3.1 Introduction.....5

3.2 Power Management .....6

3.3 Improved Current Mode.....7

3.3.1 PWM-OP .....8

3.3.2 PWM-Comparator.....9

3.4 Startup Phase .....9

3.5 PWM Section .....11

3.5.1 Oscillator .....11

3.5.2 PWM-Latch FF1.....12

3.5.3 Gate Driver.....12

3.6 Current Limiting .....13

3.6.1 Leading Edge Blanking.....13

3.6.2 Propagation Delay Compensation (patented).....14

3.7 Control Unit .....15

3.7.1 Basic and Extendable Blanking Mode .....15

3.7.2 Active Burst Mode (patented) .....16

3.7.2.1 Selectable burst entry level .....17

3.7.2.2 Entering Active Burst Mode .....18

3.7.2.3 Working in Active Burst Mode.....18

3.7.2.4 Leaving Active Burst Mode.....18

3.7.3 Protection Modes .....19

3.7.3.1 VCC OVP, OTP and VCC under voltage.....21

3.7.3.2 Over load, open loop protection .....22

3.7.4 Brown out Mode .....23

3.7.5 Action sequence at BBA pin .....25

**4 Electrical Characteristics .....27**

4.1 Absolute Maximum Ratings .....27

4.2 Absolute Maximum Ratings .....28

4.3 Characteristics.....28

4.3.1 Supply Section .....28

4.3.2 Internal Voltage Reference .....29

4.3.3 PWM Section.....29

4.3.4 Soft Start time .....29

4.3.5 Control Unit.....30

4.3.6 Current Limiting.....31

4.3.7 CoolMOS™ Section .....31

**5 CoolMOS™ Performance Characteristics .....32**

**6 Input Power Curve .....34**

**7 Outline Dimension .....35**

**8 Marking .....36**

**9 Schematic for recommended PCB layout .....37**

**Revision History .....38**

# 1 Pin Configuration and Functionality

**Table 1 Pin definitions and functions**

Pin	Symbol	Function
1	BBA	<b>BBA (Brownout, extended blanking Blanking time &amp; Auto-restart enable)</b> The BBA pin combines the functions of brownout, extendable blanking time for over load protection and the external auto-restart enable. The brownout feature is to stop the switching pulse when the input voltage is dropped to a preset low level. The extendable blanking time function is to extend the built-in 20 ms blanking time for over load protection by adding an external capacitor to ground. The external auto-restart enable function is an external access to stop the gate switching and force the IC to enter auto-restart mode. It is triggered by pulling the pin voltage to less than 0.4 V.
2	FBB	<b>FBB (Feedback &amp; Burst entry control)</b> The FBB pin combines the feedback function and the burst entry/exit control. The regulation information is provided by the FBB pin to the internal Protection Unit and the internal PWM-Comparator to control the duty cycle. The FBB-signal is the only control signal in case of light load at the Active Burst Mode. The burst entry/ exit control provides an access to select the entry/exit burst mode level.
3, 9, 10	n.c.	not connected
4	CS	<b>CS (Current Sense)</b> The Current Sense pin senses the voltage developed on the shunt resistor inserted in the source of the integrated CoolMOS™. If CS reaches the internal threshold of the Current Limit Comparator, the Driver output is immediately switched off. Furthermore the current information is provided for the PWM comparator to realize the Current Mode.
5, 6, 7, 8	Drain	<b>Drain (Drain of integrated CoolMOS™)</b> Pin Drain is the connection to the Drain of the integrated CoolMOS™.
11	VCC	<b>VCC (Power Supply)</b> The VCC pin is the positive supply of the IC. The operating range is between 10.5 V and 25 V.
12	GND	<b>GND (Ground)</b> The GND pin is the ground of the controller.

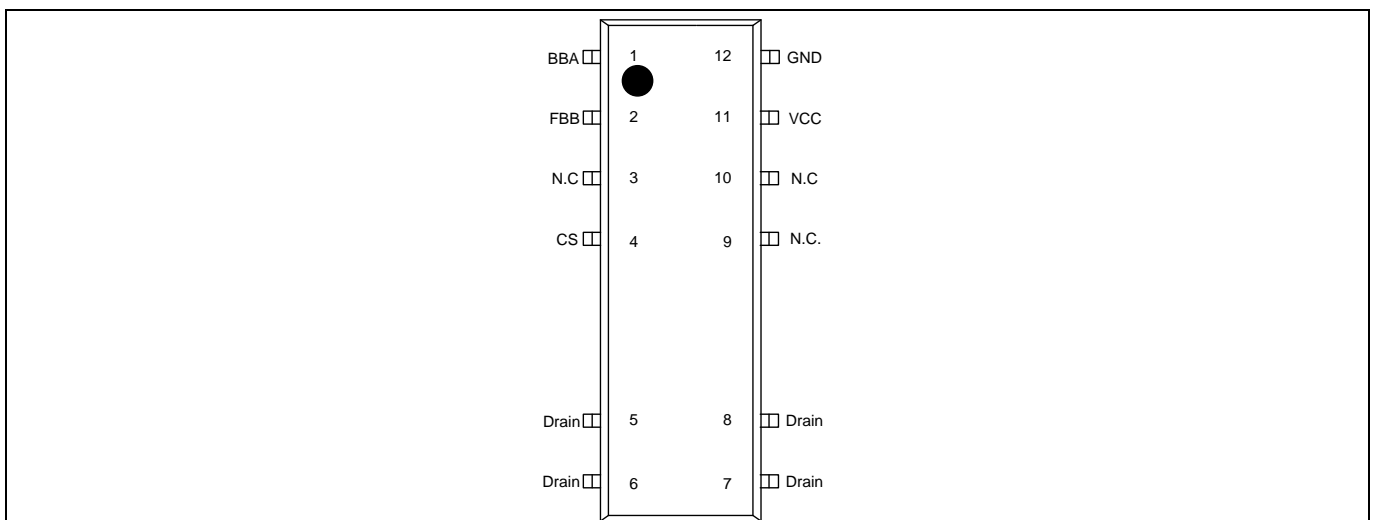

**Figure 2 Pin configuration PG-DSO-12(top view)**

## 2 Representative Block Diagram

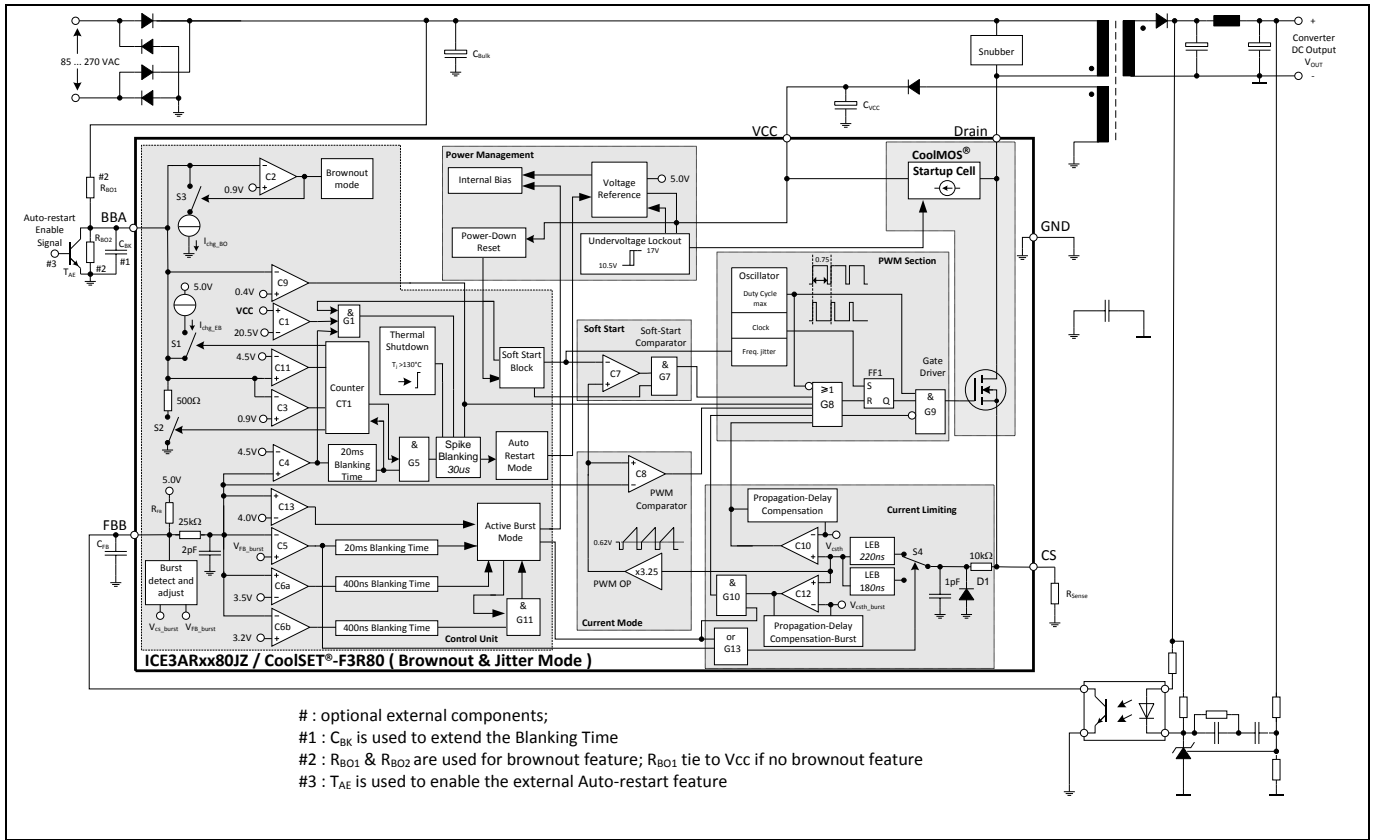

Figure 3 Representative Block Diagram

## 3 Functional Description

All values which are used in the functional description are typical values. For calculating the worst cases the min/max values which can be found in section 4 Electrical Characteristics have to be considered.

### 3.1 Introduction

CoolSET™-F3R80 brownout and jitter 800 V version (ICE3AR4780JG) is the enhanced version of the CoolSET™-F3R 650V version (ICE3BRxx65J). It is particular good for high voltage margin low power SMPS application such as auxiliary power supply for PC and server. The major characteristics are that the IC is developed with 800 V CoolMOS™ with start up cell, having adjustable brownout feature, running at 100 kHz switching frequency and packed in DIP-16/12 package. It is derived from F3R 650 V version. Thus most of the good features are retained. Besides, it includes some enhanced features and new features.

The retained good features include BiCMOS technology to reduce power consumption and increase the Vcc voltage range, cycle by cycle current mode control, built-in 10ms soft start to reduce the stress of switching elements during start up, built-in 20 ms and extended blanking time for short period of peak power before entering protection, active burst mode for lowest standby power and propagation delay compensation for close power limit between high line and low line, frequency jittering for low EMI performance, the built-in auto-restart mode protections for open loop, over load, Vcc OVP, Vcc under voltage, etc. and also the most flexible external auto-restart enable, etc.

The enhanced features include narrowing the feedback voltage swing from 0.5V to 0.3V during burst mode so that the output voltage ripple can be reduced by 40%, reduction of the fast voltage fall time of the MOSFET by increasing the soft turn-on time and addition of 50 Ω turn-on resistor, faster start up time by optimizing the VCC capacitor to 10 μF and over temperature protection with 50°C hysteresis.

The new features include adjustable brownout for reliable output performance, selectable entry and exit burst mode so that smaller entry/exit power to burst mode or even no burst mode is possible and the propagation delay compensation for burst mode so that the entry/exit burst mode power is close between high line and low line.

In summary, the CoolSET™ F3R80 provides good voltage margin of MOSFET, lowest standby power, flexible burst level, reduced output ripple during burst mode, reliable output with brownout feature, accurate power limit for both maximum power and burst power, low EMI with frequency jittering and soft gate drive, built-in and flexible protections, etc. Therefore, CoolSET™ F3R80 is a complete solution for the low power SMPS application.

### 3.2 Power Management

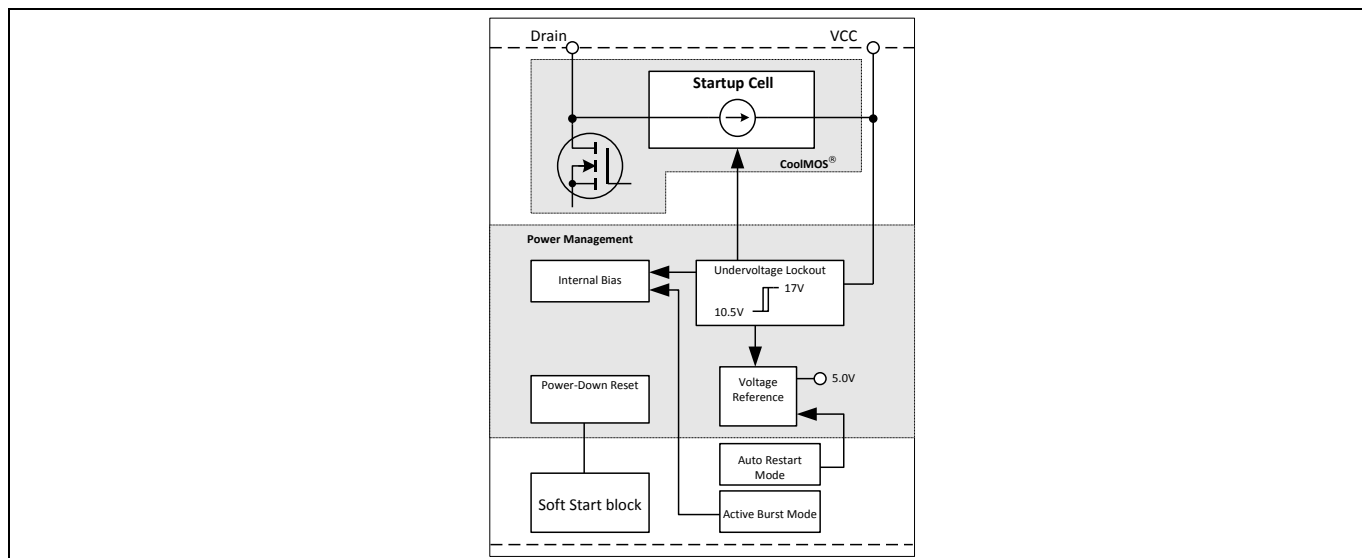

**Figure 4 Power Management**

The Undervoltage Lockout monitors the external supply voltage  $V_{VCC}$ . When the SMPS is plugged to the main line the internal Startup Cell is biased and starts to charge the external capacitor  $C_{VCC}$  which is connected to the VCC pin. This VCC charge current is controlled to 0.9 mA by the Startup Cell. When the  $V_{VCC}$  exceeds the on-threshold  $V_{VCCon} = 17\text{ V}$  the bias circuit are switched on. Then the Startup Cell is switched off by the Undervoltage Lockout and therefore no power losses present due to the connection of the Startup Cell to the Drain voltage. To avoid uncontrolled ringing at switch-on, a hysteresis start up voltage is implemented. The switch-off of the controller can only take place when  $V_{VCC}$  falls below 10.5 V after normal operation was entered. The maximum current consumption before the controller is activated is about 200  $\mu\text{A}$ .

When  $V_{VCC}$  falls below the off-threshold  $V_{VCCoff} = 10.5\text{ V}$ , the bias circuit is switched off and the soft start counter is reset. Thus it ensures that at every startup cycle the soft start starts at zero.

The internal bias circuit is switched off if Auto Restart Mode is entered. The current consumption is then reduced to 320  $\mu\text{A}$ .

Once the malfunction condition is removed, this block will then turn back on. The recovery from Auto Restart Mode does not require re-cycling the AC line.

When Active Burst Mode is entered, the internal Bias is switched off most of the time but the Voltage Reference is kept alive in order to reduce the current consumption below 620  $\mu\text{A}$ .

### 3.3 Improved Current Mode

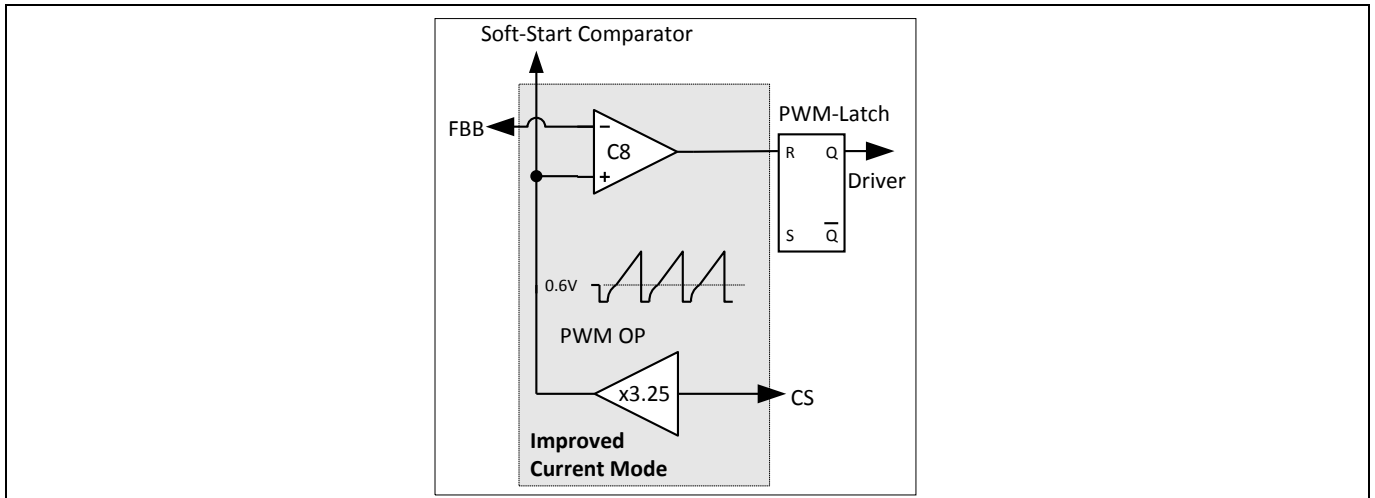

**Figure 5 Current Mode**

Current Mode means the duty cycle is controlled by the slope of the primary current. This is done by comparing the FBB signal with the amplified current sense signal.

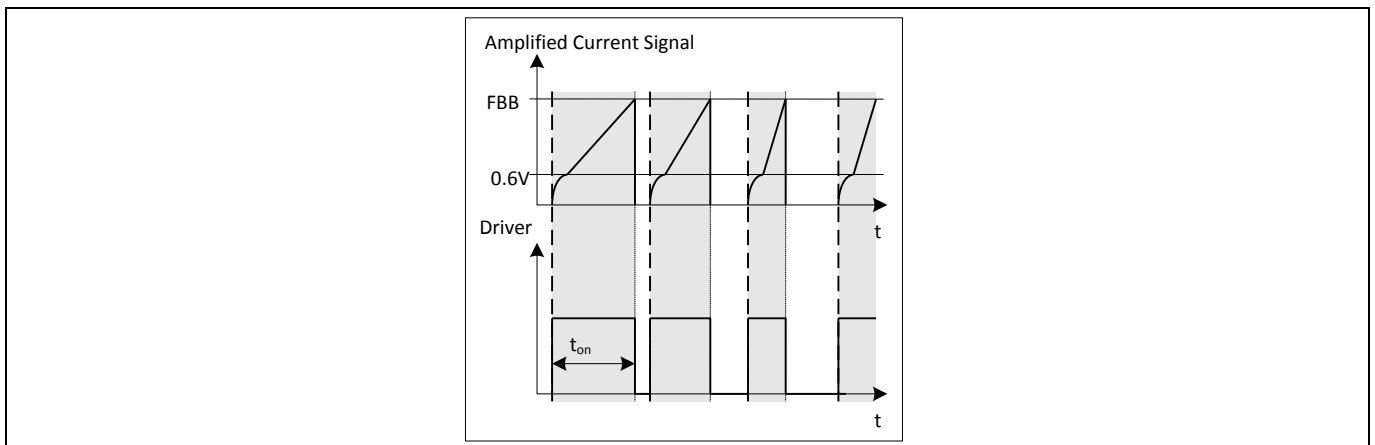

**Figure 6 Pulse Width Modulation**

In case the amplified current sense signal exceeds the FBB signal the on-time  $t_{on}$  of the driver is finished by resetting the PWM-Latch (Figure 6).

The primary current is sensed by the external series resistor  $R_{Sense}$  inserted in the source of the integrated CoolMOS™. By means of Current Mode regulation, the secondary output voltage is insensitive to the line variations. The current waveform slope will change with the line variation, which controls the duty cycle.

The external  $R_{Sense}$  allows an individual adjustment of the maximum source current of the integrated CoolMOS™.

To improve the Current Mode during light load conditions the amplified current ramp of the PWM-OP is superimposed on a voltage ramp, which is built by the switch T2, the voltage source V1 and a resistor R1 (Figure 6). Every time the oscillator shuts down for maximum duty cycle limitation the switch T2 is closed by  $V_{osc}$ . When the oscillator triggers the Gate Driver, T2 is opened so that the voltage ramp can start.

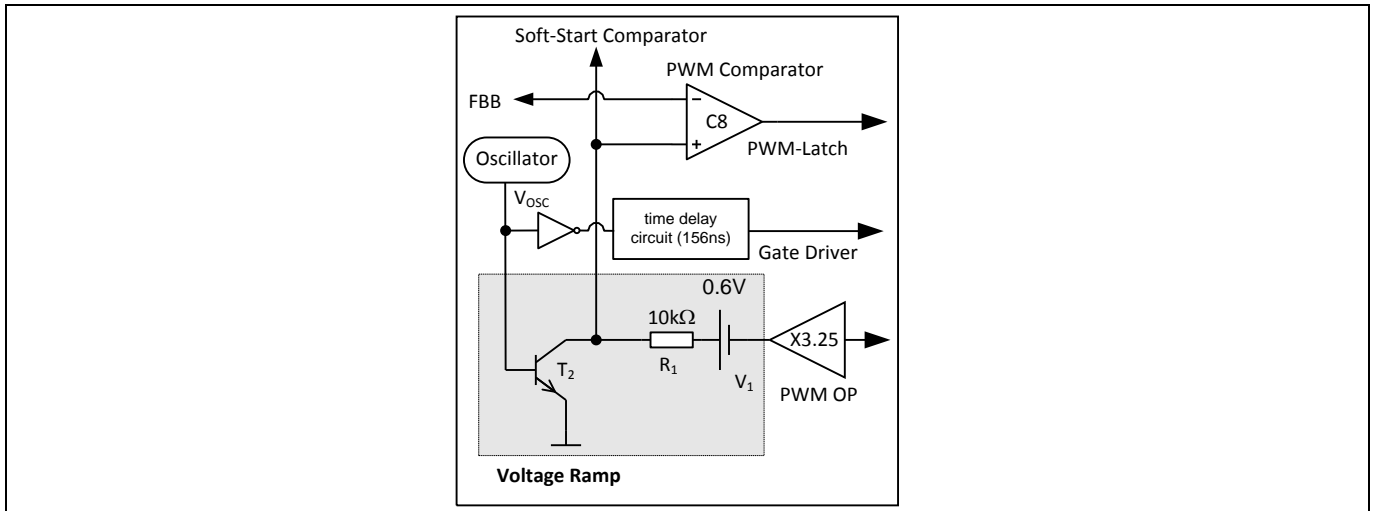

**Figure 7 Improved Current Mode**

In case of light load the amplified current ramp is too small to ensure a stable regulation. In that case the Voltage Ramp is a well defined signal for the comparison with the FBB-signal. The duty cycle is then controlled by the slope of the Voltage Ramp.

By means of the time delay circuit which is triggered by the inverted VOSC signal, the Gate Driver is switched-off until it reaches approximately 156 ns delay time (Figure 8). It allows the duty cycle to be reduced continuously till 0% by decreasing  $V_{FBB}$  below that threshold.

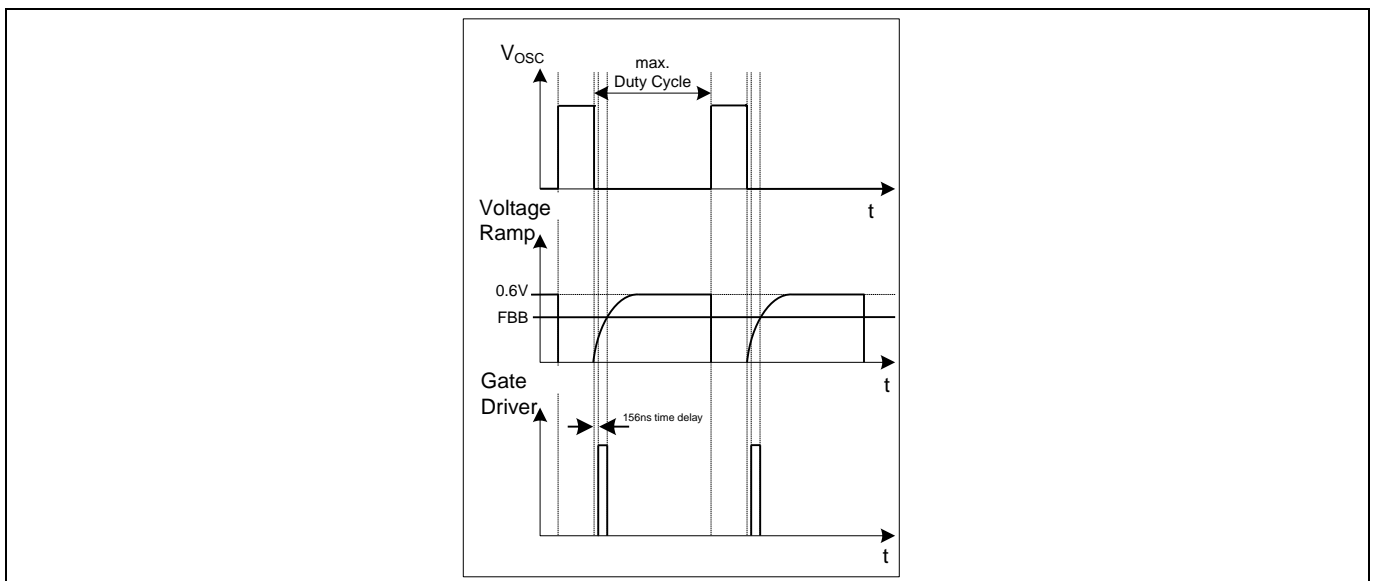

**Figure 8 Light Load Conditions**

### 3.3.1 PWM-OP

The input of the PWM-OP is applied over the internal leading edge blanking to the external sense resistor  $R_{Sense}$  connected to pin CS.  $R_{Sense}$  converts the source current into a sense voltage. The sense voltage is amplified with a gain of 3.25 by PWM OP. The output of the PWM-OP is connected to the voltage source  $V_1$ . The voltage ramp with the superimposed amplified current signal is fed into the positive inputs of the PWM-Comparator C8 and the Soft-Start-Comparator (Figure 9).

### 3.3.2 PWM-Comparator

The PWM-Comparator compares the sensed current signal of the integrated CoolMOS™ with the feedback signal  $V_{FBB}$  (Figure 9).  $V_{FBB}$  is created by an external optocoupler or external transistor in combination with the internal pull-up resistor  $R_{FB}$  and provides the load information of the feedback circuitry. When the amplified current signal of the integrated CoolMOS™ exceeds the signal  $V_{FBB}$  the PWM-Comparator switches off the Gate Driver.

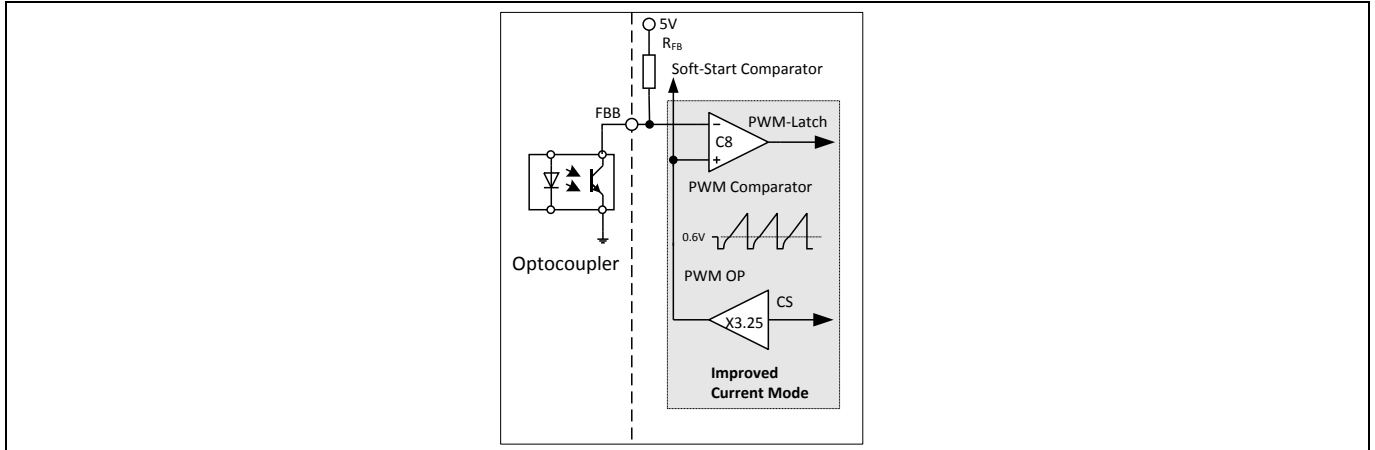

Figure 9 PWM Controlling

### 3.4 Startup Phase

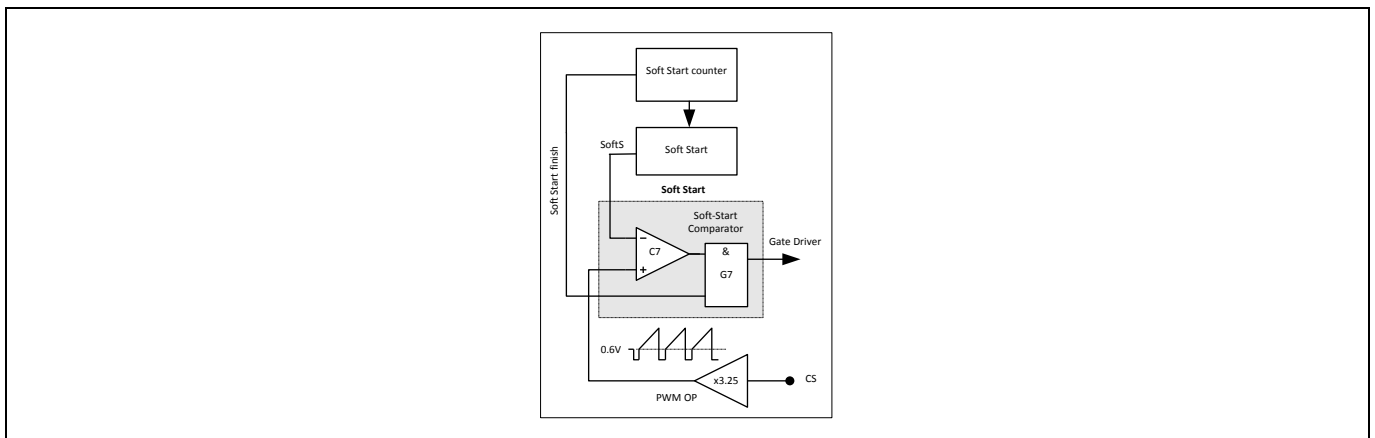

Figure 10 Soft Start

In the Startup Phase, the IC provides a Soft Start period to control the primary current by means of a duty cycle limitation. The Soft Start function is a built-in function and it is controlled by an internal counter.

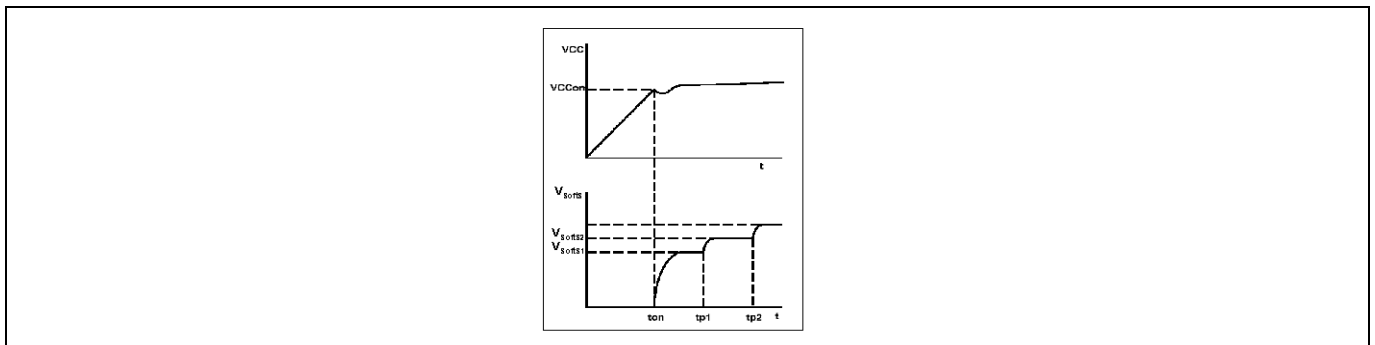
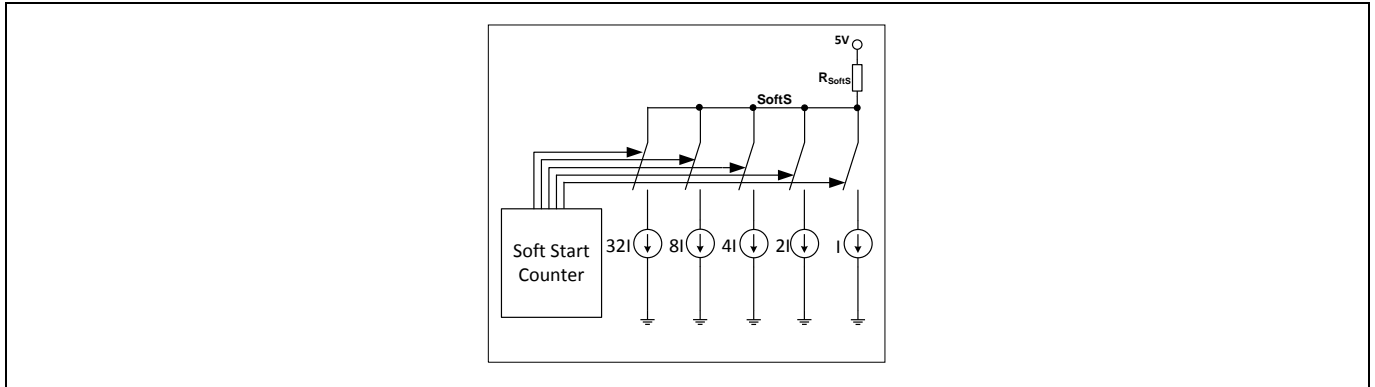

Figure 11 Soft Start Phase

When the  $V_{VCC}$  exceeds the on-threshold voltage, the IC starts the Soft Start mode (Figure 11).

The function is realized by an internal Soft Start resistor, a current sink and a counter. And the amplitude of the current sink is controlled by the counter (Figure 12).



**Figure 12 Soft Start Circuit**

After the IC is switched on, the  $V_{SoftS}$  voltage is controlled such that the voltage is increased step-wisely (32 steps) with the increase of the counts. The Soft Start counter would send a signal to the current sink control in every  $300 \mu s$  such that the current sink decrease gradually and the duty ratio of the gate drive increases gradually. The Soft Start will be finished in  $10 ms$  ( $t_{Soft-Start}$ ) after the IC is switched on. At the end of the Soft Start period, the current sink is switched off.

Within the soft start period, the duty cycle is increasing from zero to maximum gradually (Figure 12).

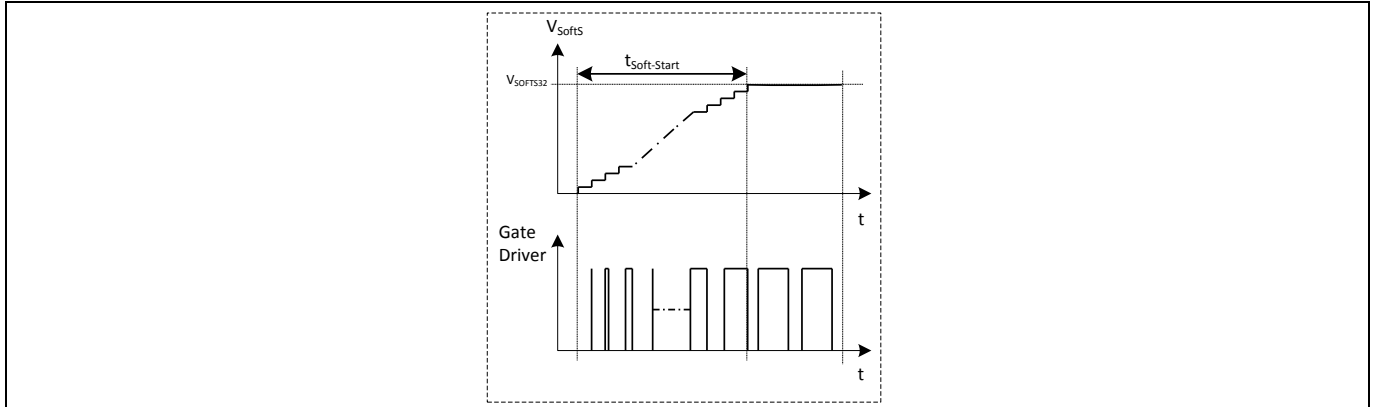

**Figure 13 Gate drive signal under Soft-Start Phase**

In addition to Start-Up, Soft-Start is also activated at each restart attempt during Auto Restart.

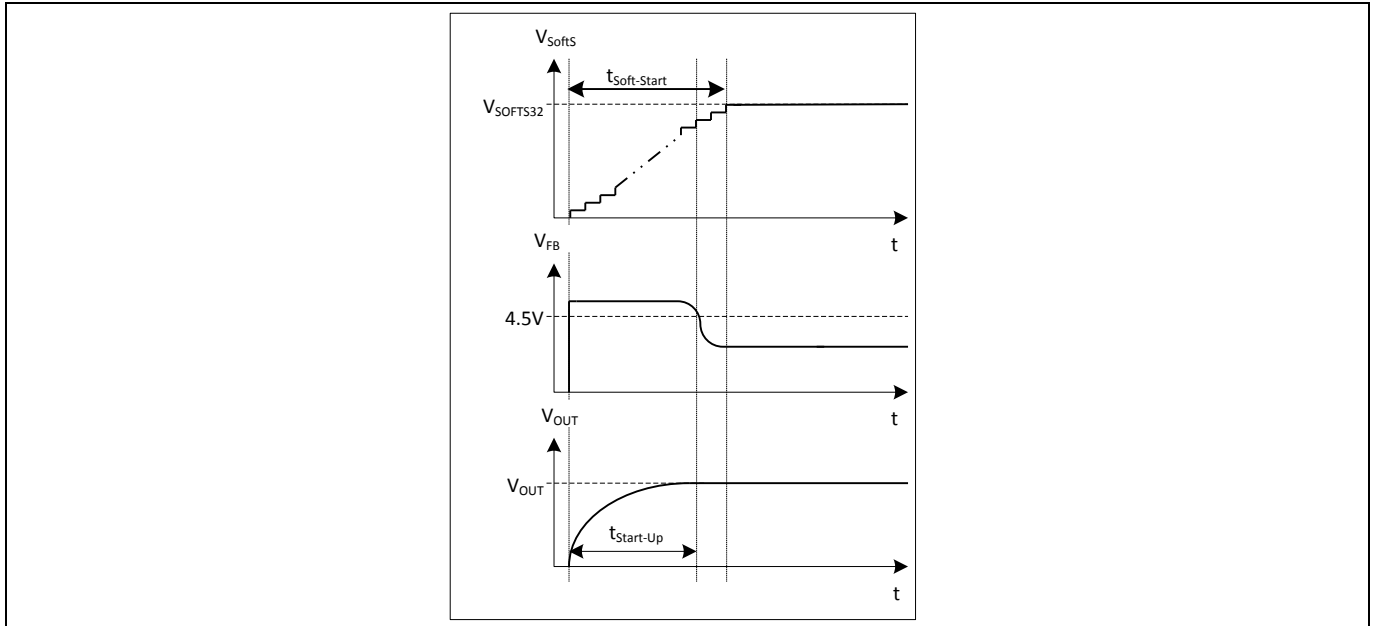

**Figure 14 Start Up Phase**

The Start-Up time  $t_{Start-Up}$  before the converter output voltage  $V_{OUT}$  is settled must be shorter than the Soft-Start Phase  $t_{Soft-Start}$  (Figure 14). By means of Soft-Start there is an effective minimization of current and voltage stresses on the integrated CoolMOS™, the clamp circuit and the output rectifier and it helps to prevent saturation of the transformer during Start-Up.

### 3.5 PWM Section

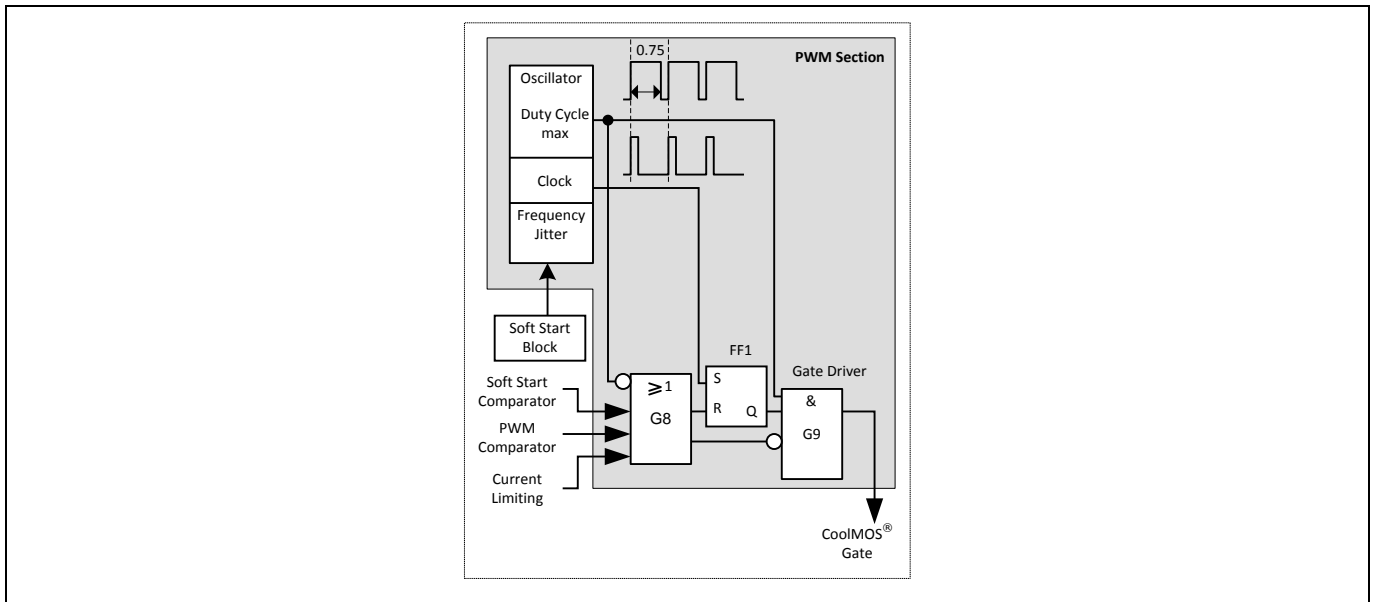

**Figure 15 PWM Section Block**

#### 3.5.1 Oscillator

The oscillator generates a fixed frequency of 100 kHz with frequency jittering of  $\pm 4\%$  (which is  $\pm 4$  kHz) at a jittering period of 4 ms.

A capacitor, a current source and current sink which determine the frequency are integrated. The charging and discharging current of the implemented oscillator capacitor are internally trimmed in order to achieve a very

accurate switching frequency. The ratio of controlled charge to discharge current is adjusted to reach a maximum duty cycle limitation of  $D_{max} = 0.75$ .

Once the Soft Start period is over and when the IC goes into normal operating mode, the switching frequency of the clock is varied by the control signal from the Soft Start block. Then the switching frequency is varied in range of  $100\text{ kHz} \pm 4\text{ kHz}$  at period of 4 ms.

### 3.5.2 PWM-Latch FF1

The output of the oscillator block provides continuous pulse to the PWM-Latch which turns on/off the integrated CoolMOS™. After the PWM-Latch is set, it is reset by the PWM comparator, the Soft Start comparator or the Current -Limit comparator. When it is in reset mode, the output of the driver is shut down immediately.

### 3.5.3 Gate Driver

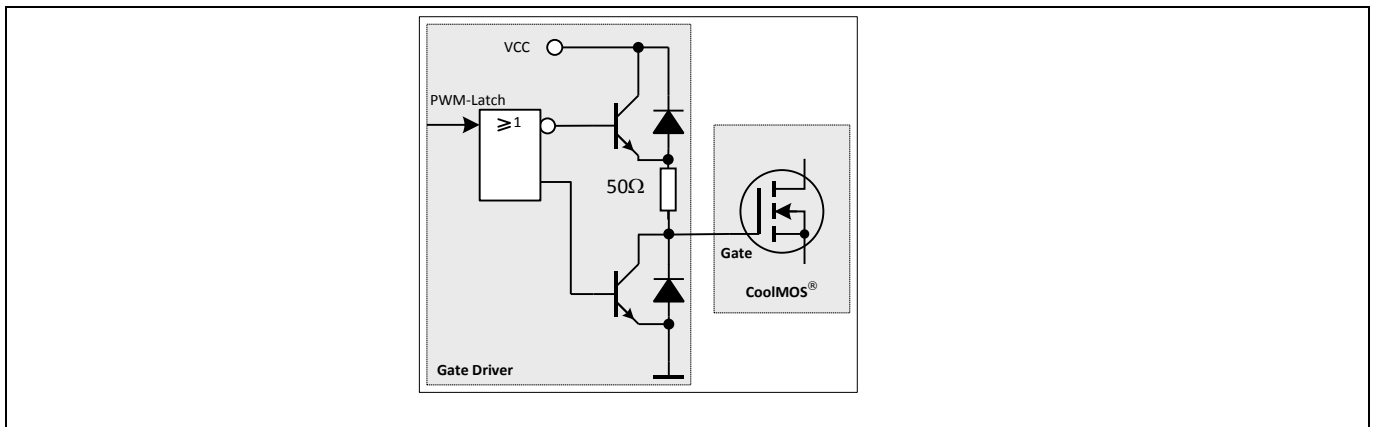

**Figure 16 Gate Driver**

The driver-stage is optimized to minimize EMI and to provide high circuit efficiency. This is done by reducing the switch on slope when exceeding the integrated CoolMOS™ threshold. This is achieved by a slope control of the rising edge at the driver’s output (Figure 17) and adding a 50 Ω gate turn on resistor (Figure 16). Thus the leading switch on spike is minimized.

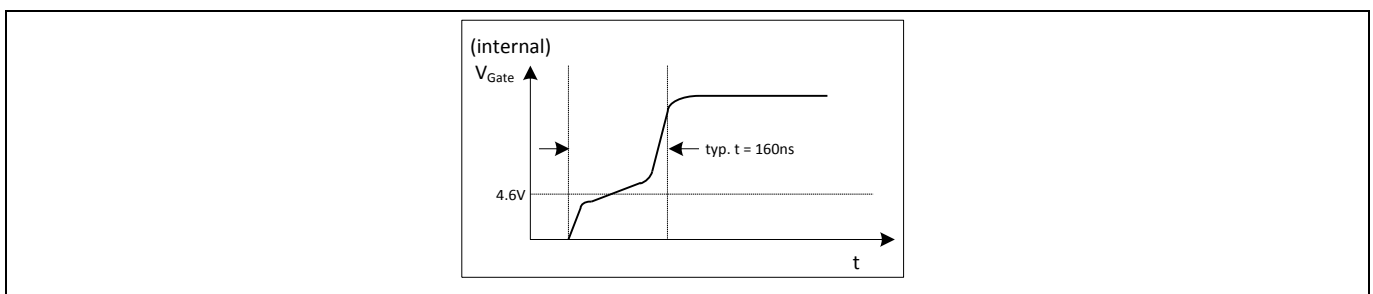
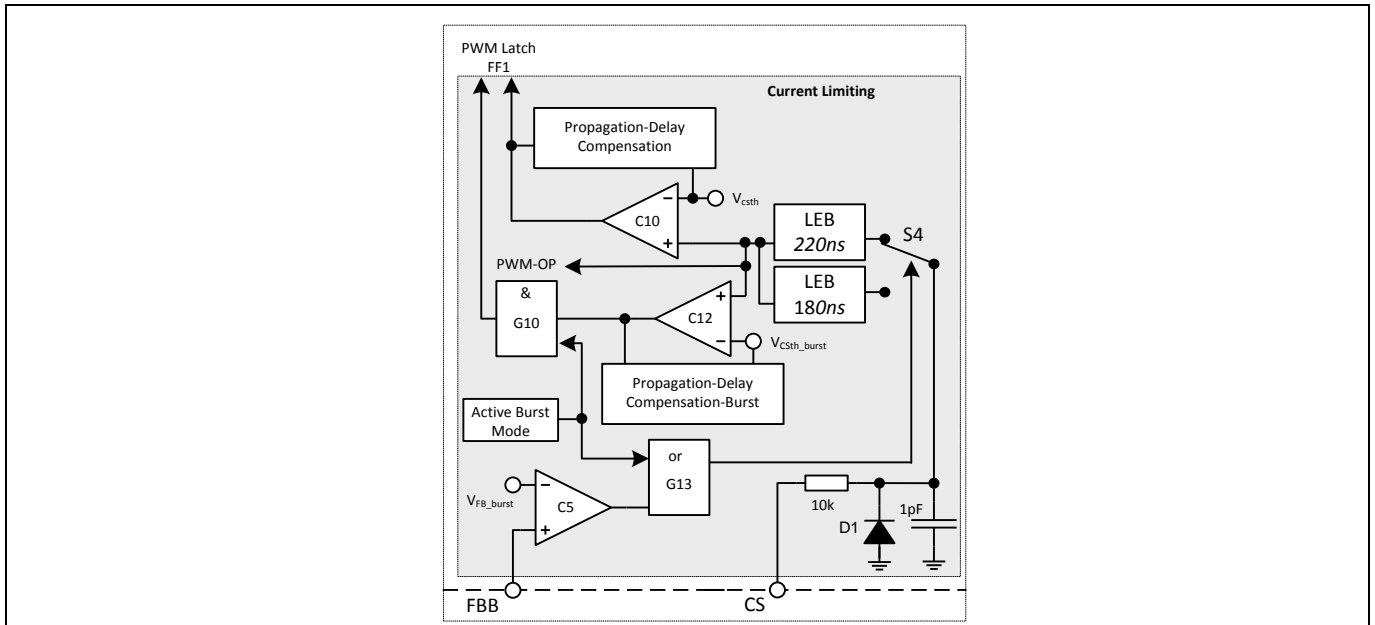

**Figure 17 Gate Rising Slope**

Furthermore the driver circuit is designed to eliminate cross conduction of the output stage.

During power up, when VCC is below the undervoltage lockout threshold  $V_{VCCoff}$ , the output of the Gate Driver is set to low in order to disable power transfer to the secondary side.

### 3.6 Current Limiting



**Figure 18 Current Limiting Block**

There is a cycle by cycle peak current limiting operation realized by the Current-Limit comparator C10. The source current of the integrated CoolMOS™ is sensed via an external sense resistor  $R_{Sense}$ . By means of  $R_{Sense}$  the source current is transformed to a sense voltage  $V_{Sense}$  which is fed into the pin CS. If the voltage  $V_{Sense}$  exceeds the internal threshold voltage  $V_{csth}$ , the comparator C10 immediately turns off the gate drive by resetting the PWM Latch FF1.

A Propagation Delay Compensation is added to support the immediate shut down of the integrated CoolMOS™ with very short propagation delay. Thus the influence of the AC input voltage on the maximum output power can be reduced to minimal. This compensation applies to both the peak load and burst mode.

In order to prevent the current limit from distortions caused by leading edge spikes, a Leading Edge Blanking (LEB) is integrated in the current sense path for the comparators C10, C12 and the PWM-OP.

The output of comparator C12 is activated by the Gate G10 if Active Burst Mode is entered. When it is activated, the current limiting is reduced to  $V_{csth\_burst}$ . This voltage level determines the maximum power level in Active Burst Mode.

#### 3.6.1 Leading Edge Blanking

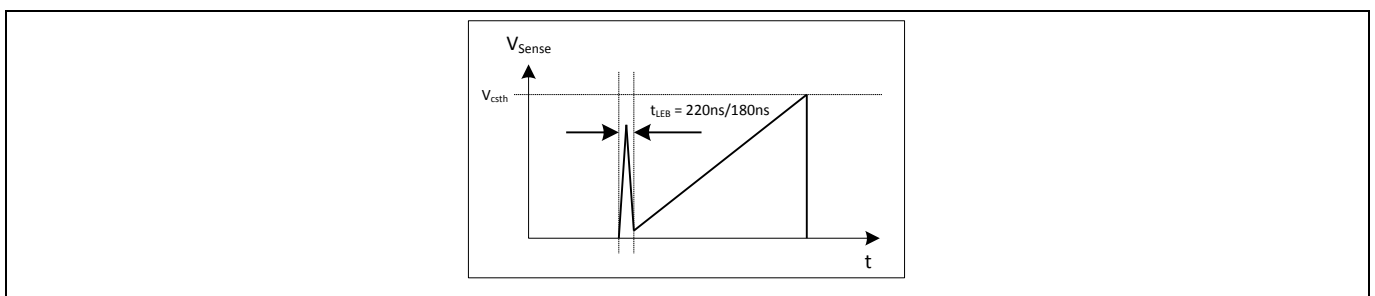

**Figure 19 Leading Edge Blanking**

Whenever the integrated CoolMOS™ is switched on, a leading edge spike is generated due to the primary-side capacitances and reverse recovery time of the secondary-side rectifier. This spike can cause the gate drive to

switch off unintentionally. In order to avoid a premature termination of the switching pulse, this spike is blanked out with a time constant of  $t_{LEB} = 220 \text{ ns}$  for normal load and  $t_{LEB} = 180 \text{ ns}$  for burst mode.

### 3.6.2 Propagation Delay Compensation (patented)

In case of overcurrent detection, there is always propagation delay to switch off the integrated CoolMOS™. An overshoot of the peak current  $I_{peak}$  is induced to the delay, which depends on the ratio of  $di/dt$  of the peak current (Figure 20).

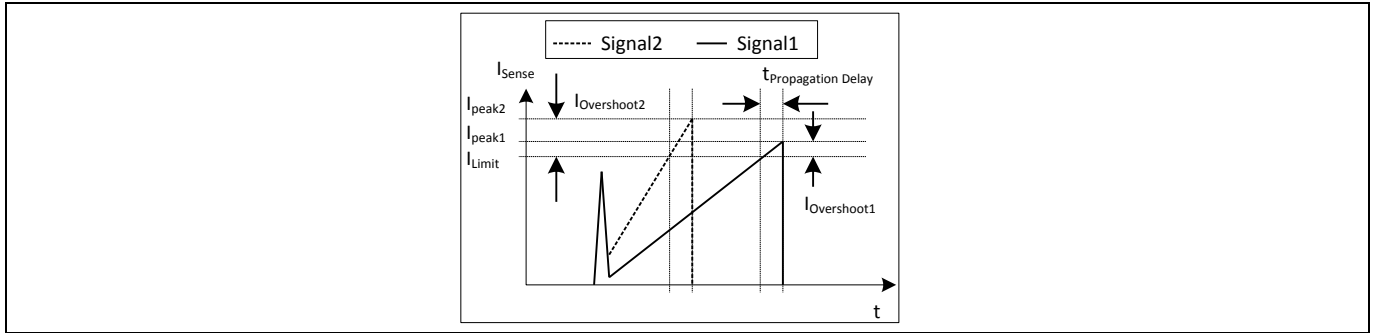

Figure 20 Current Limiting

The overshoot of Signal 2 is larger than of Signal 1 due to the steeper rising waveform. This change in the slope is depending on the AC input voltage. Propagation Delay Compensation is integrated to reduce the overshoot due to  $di/dt$  of the rising primary current. Thus the propagation delay time between exceeding the current sense threshold  $V_{csth}$  and the switching off of the integrated CoolMOS™ is compensated over temperature within a wide input range. Current Limiting is then very accurate.

For example,  $I_{peak} = 0.5 \text{ A}$  with  $R_{sense} = 2$ . The current sense threshold is set to a static voltage level  $V_{csth} = 1 \text{ V}$  without Propagation Delay Compensation. A current ramp of  $di/dt = 0.4 \text{ A}/\mu\text{s}$ , or  $dV_{sense}/dt = 0.8 \text{ V}/\mu\text{s}$ , and a propagation delay time of  $t_{propagation \text{ Delay}} = 180 \text{ ns}$  leads to an  $I_{peak}$  overshoot of 14.4%. With the propagation delay compensation, the overshoot is only around 2% (Figure 21).

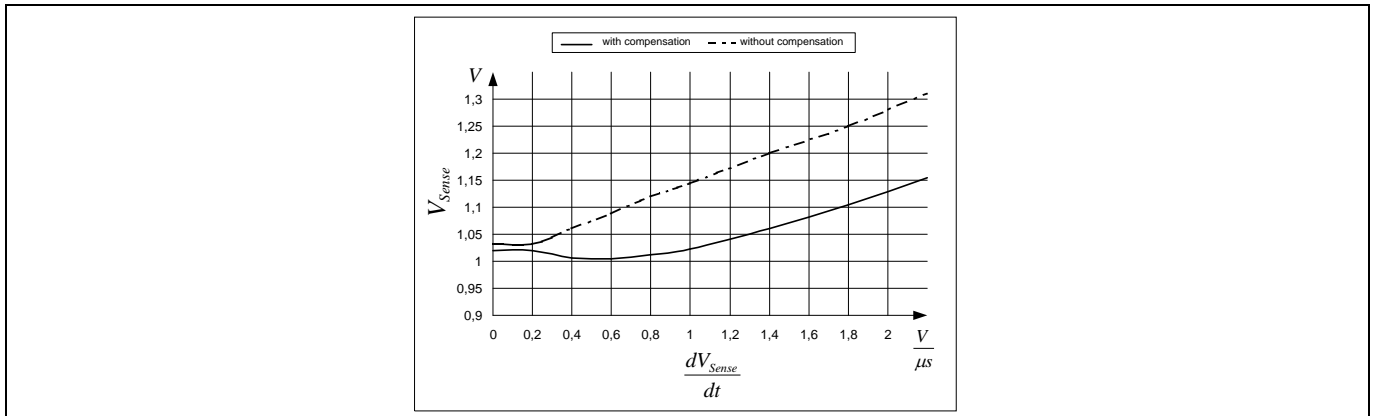
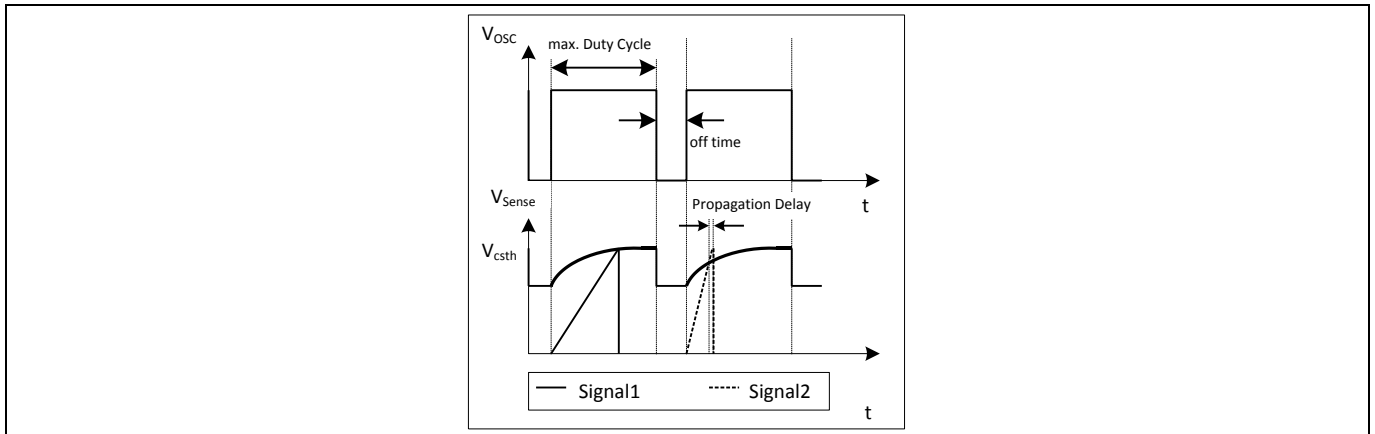

Figure 21 Overcurrent Shutdown

The Propagation Delay Compensation is realized by means of a dynamic threshold voltage  $V_{csth}$  (Figure 21). In case of a steeper slope the switch off of the driver is earlier to compensate the delay.



**Figure 22** Dynamic Voltage Threshold  $V_{csth}$

Similarly, the same concept of propagation delay compensation is also implemented in burst mode with reduced level,  $V_{csth\_burst}$  (Figure 18). With this implementation, the entry and exit burst mode power can be very close between low line and high line input voltage.

### 3.7 Control Unit

The Control Unit contains the functions for Active Burst Mode and Auto Restart Mode. The Active Burst Mode and the Auto Restart Mode both have 20 ms internal blanking time. For the over load Auto Restart Mode, the 20 ms blanking time can be further extended by adding an external capacitor at BV pin. With the blanking time, the IC avoids entering into those two modes accidentally. That buffer time is very useful for the application which works in short duration of peak power occasionally.

#### 3.7.1 Basic and Extendable Blanking Mode

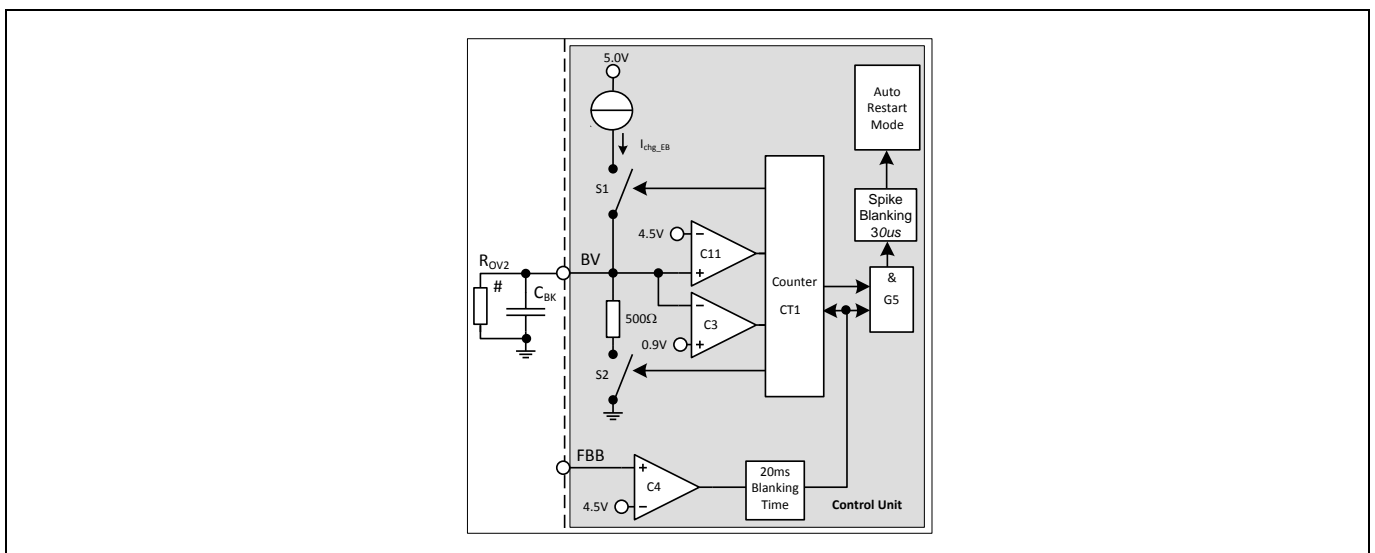

**Figure 23** Basic and Extendable Blanking Mode

There are 2 kinds of Blanking mode; basic mode and the extendable mode. The basic mode is a built-in 20 ms blanking time while the extendable mode can extend this blanking time by connecting an external capacitor to the BBA pin. For the extendable mode, the gate G5 remains blocked even though the 20 ms blanking time is reached. After reaching the 20 ms blanking time the counter is activated and the switch S1 is turned on to charge the voltage of BBA pin by the constant current source,  $I_{chg\_EB}$ . When the voltage of BBA pin hits 4.5 V, which is sensed by comparator C11, the counter will increase the counter by 1. Then it switches off the switch

S1 and turns on the switch S2. The voltage at BBA pin will be discharged through a 500 Ω resistor. When the voltage drops to 0.9 V which is sensed by comparator C3, the switch S2 will be turned off and the switch S1 will be turned on. Then the constant current  $I_{chg\_EB}$  will charge the CBK capacitor again. When the voltage at BBA hits 4.5 V which is sensed by comparator C11, the counter will increase the count to 2. The process repeats until it reaches total count of 256 (Figure 24). Then the counter will release a high output signal. When the AND gate G5 detects both high signals at the inputs, it will activate the 30ms spike blanking circuit and finally the auto-restart mode will be activated.

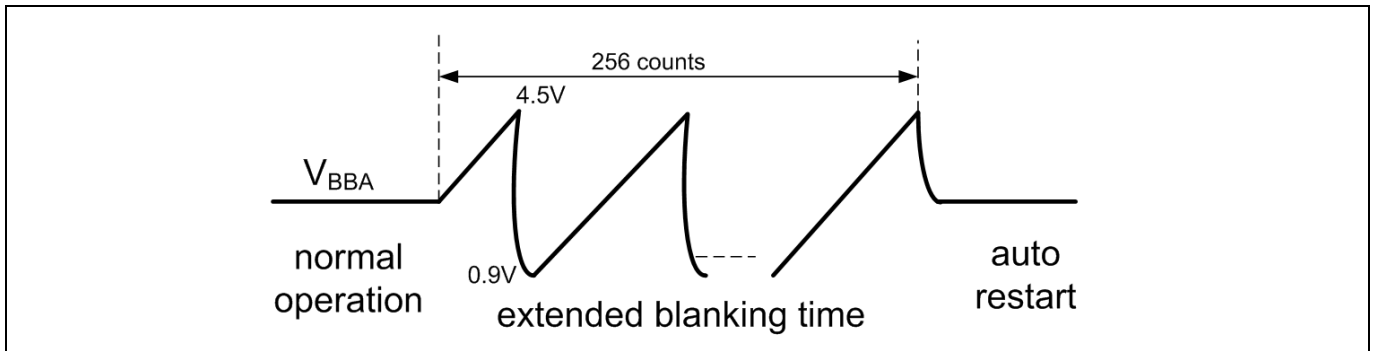

**Figure 24** Waveform at extended blanking time

For example, if  $C_{BK}=0.1 \mu F$ ,  $I_{chg\_EB}=720 \text{ mA}$

$$\text{Extended blanking time} = 256 * (C_{BK} * (4.5 \text{ V} - 0.9 \text{ V}) / I_{chg\_EB} + C_{BK} * 500 * \ln(4.5/0.9)) = 148.6 \text{ ms}$$

$$\text{Total blanking time} = 20 \text{ ms} + 148.6 \text{ ms} = 168.6 \text{ ms}$$

If there is a resistor  $R_{B02}$  connected to BBA pin, the effective charging current will be reduced. The blanking time will be increased.

For example, if  $C_{BK}=0.1 \mu F$ ,  $I_{chg\_EB}=720 \text{ mA}$ ,  $R_{B02}=12.8 \text{ k}\Omega$ ,

$$I_{chg\_EB}' = I_{chg\_EB} - (4.5 \text{ V} + 0.9 \text{ V}) / (2 * R_{B02}) = 509 \text{ mA}$$

$$\text{Extended blanking time} = 256 * (C_{BK} * (4.5 \text{ V} - 0.9 \text{ V}) / I_{chg\_EB}' + C_{BK} * 500 * \ln(4.5/0.9)) = 201.6 \text{ ms}$$

$$\text{Total blanking time} = 20 \text{ ms} + 201.6 \text{ ms} = 221.6 \text{ ms}$$

where  $I_{chg\_EB}' = \text{net charging current to } C_{BK}$

*Note: The above calculation does not include the effect of the brown out circuit where there is extra biasing current flowing from the input. That means the extended blanking time will be shortened with the line voltage change if brown out circuit is implemented.*

### 3.7.2 Active Burst Mode (patented)

To increase the efficiency of the system at light load, the most effective way is to operate at burst mode. Starting from CoolSET™ F3, the IC has been employing the active burst mode and it can achieve the lowest standby power. ICE3AR4780JG adopts the same concept with some more innovative improvements to the feature. It includes the adjustable entry burst level, close power control between high line and low line and the smaller output ripple during burst mode.

Most of the burst mode design in the market will provide a fixed entry burst mode level which is a ratio to the maximum power of the design. ICE3AR4780JG provides a more flexible level which can be selected externally. The provision also includes not entering burst mode.

Propagation delay is the major contributor for the power control variation for DCM flyback converter. It is proved to be effective in the maximum power control. ICE3AR4780JG also apply the same concept in the burst mode. Therefore, the entry and exit burst mode power is also finely controlled during burst mode.

The feedback control swing during burst mode will affect the output ripple voltage directly. ICE3AR4780JG reduces the swing from 0.5 V to 0.3 V. Therefore, it would have around 40% improvement for the output ripple.

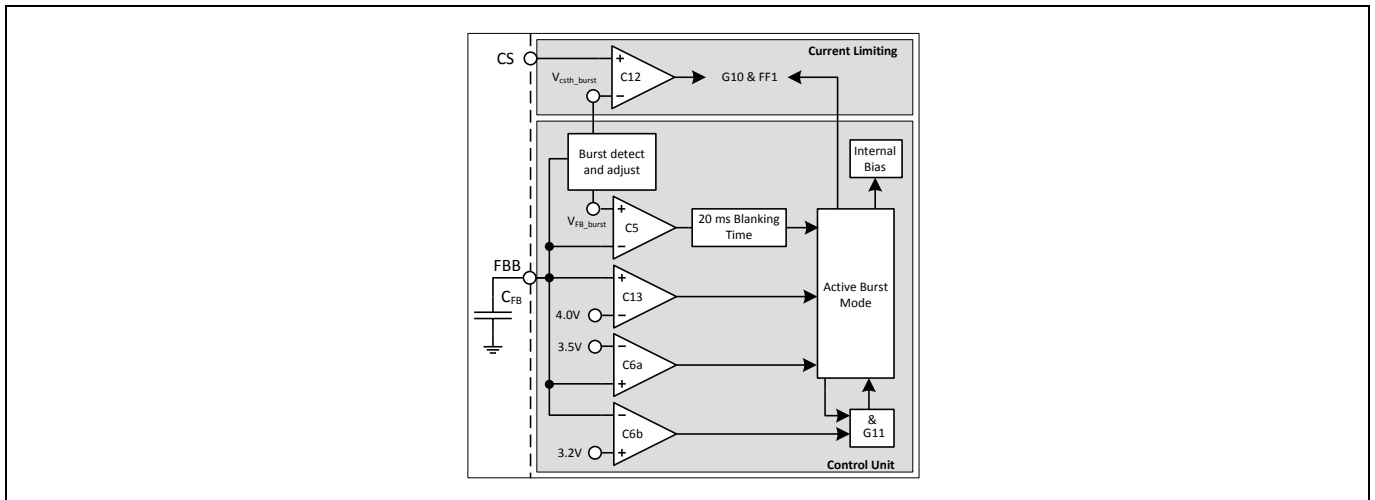

Figure 25 Active Burst Mode

### 3.7.2.1 Selectable burst entry level

The burst mode entry level can be selected by changing the different capacitor  $C_{FB}$  at FBB pin. There are 4 levels to be selected with different capacitor which are targeted for 10%, 6.67%, 4.38% and 0% of the maximum input power. At the same time, the exit burst levels are targeted to 20%, 13.3%, 9.6% and 0% of the maximum power accordingly. The corresponding capacitance range is from 6.8 nF to 100 pF. The below table is the recommended capacitance range for the entry and exit level with the  $C_{FB}$  capacitor.

Table 2  $C_{FB}$  versus active burst mode entry/exit level

$C_{FB}$	Entry level		Exit level	
	% of $P_{in\_max}$	$V_{FB\_burst}$	% of $P_{in\_max}$	$V_{csth\_burst}$
$\geq 6.8$ nF (5%, X7R)	10%	1.60 V	20%	0.45 V
1nF~2.2 nF (1%, COG)	6.67%	1.42 V	13.3%	0.37 V
220pF~470 pF (1%, COG)	4.38%	1.27 V	9.6%	0.31 V
$\leq 100$ pF (1%, COG)	0%	never	0%	always

The selection is at the 1st 1ms of the UVLO “ON” ( $V_{VCC} > 17$  V) during the 1st start up but it does not detect in the subsequent re-start due to auto-restart protection. In case there is protection triggered such as brown out before starts up, the detection will be held until the protection is removed. When the  $V_{CC}$  reaches the UVLO “ON” in the 1st start up, the capacitor  $C_{FB}$  at FBB pin is charged by a 5V voltage source through the RFB resistor. When the voltage at FBB pin hits 4.5 V, the FF4 will be set, the switch S9 is turned “ON” and the counter will increase by 1. Then the  $C_{FB}$  is discharged through a 500  $\Omega$  resistor. After reaching 0.5 V, the FF4 is reset and the switch S9 is turned “OFF”. Then the  $C_{FB}$  capacitor is charged by the 5V voltage source again until it reaches 4.5 V. The process repeats until the end of 1 ms. Then the detection is ended. After that, the total number of count in the counter is compared and the  $V_{FB\_burst}$  and the  $V_{cs\_burst}$  are selected accordingly (Figure 26)

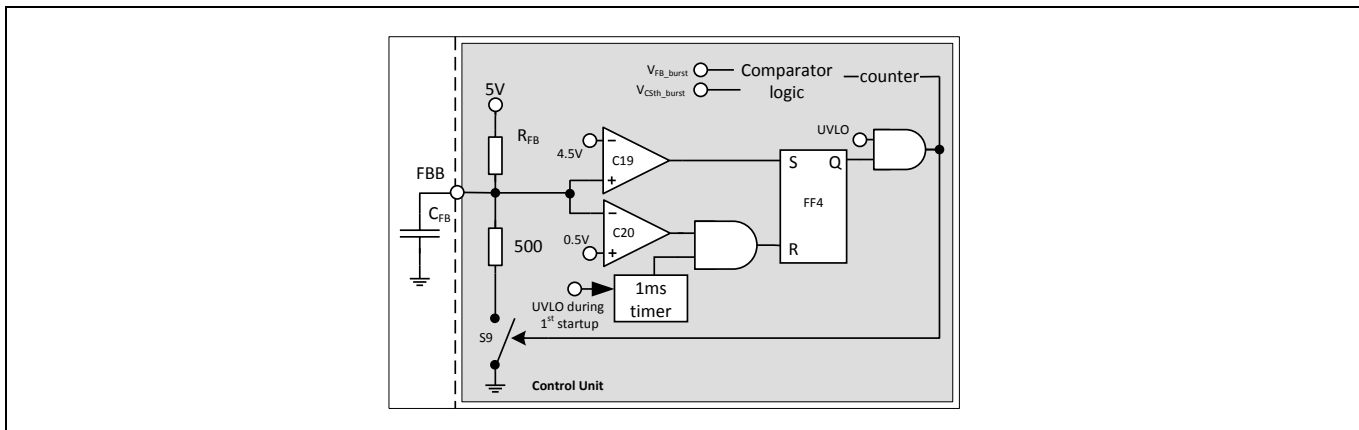

Figure 26 Active Burst Mode

### 3.7.2.2 Entering Active Burst Mode

The FBB signal is kept monitoring by the comparator C5 (Figure 25). During normal operation, the internal blanking time counter is reset to 0. When FBB signal falls below  $V_{FB\_burst}$ , it starts to count. When the counter reaches 20 ms and FBB signal is still below  $V_{FB\_burst}$ , the system enters the Active Burst Mode. This time window prevents a sudden entering into the Active Burst Mode due to large load jumps.

After entering Active Burst Mode, a burst flag is set and the internal bias is switched off in order to reduce the current consumption of the IC to about 620  $\mu$ A.

It needs the application to enforce the VCC voltage above the Undervoltage Lockout level of 10.5 V such that the Startup Cell will not be switched on accidentally. Or otherwise the power loss will increase drastically. The minimum VCC level during Active Burst Mode depends on the load condition and the application. The lowest VCC level is reached at no load condition.

### 3.7.2.3 Working in Active Burst Mode

After entering the Active Burst Mode, the FBB voltage rises as  $V_{OUT}$  starts to decrease, which is due to the inactive PWM section. The comparator C6a monitors the FBB signal. If the voltage level is larger than 3.5 V, the internal circuit will be activated; the Internal Bias circuit resumes and starts to provide switching pulse. In Active Burst Mode the gate G10 is released and the current limit is reduced to  $V_{csth\_burst}$  (Figure 3 and Figure 25). In one hand, it can reduce the conduction loss and the other hand, it can reduce the audible noise. If the load at  $V_{OUT}$  is still kept unchanged, the FBB signal will drop to 3.2 V. At this level the C6b deactivates the internal circuit again by switching off the Internal Bias. The gate G11 is active again as the burst flag is set after entering Active Burst Mode. In Active Burst Mode, the FBB voltage is changing like a saw tooth between 3.2 V and 3.5 V (Figure 27).

### 3.7.2.4 Leaving Active Burst Mode

The FBB voltage will increase immediately if there is a high load jump. This is observed by the comparator C13 (Figure 25). Since the current limit is reduced to 31%~45% of the maximum current during active burst mode, it needs a certain load jump to raise the FBB signal to exceed 4.0 V. At that time the comparator C5 resets the Active Burst Mode control which in turn blocks the comparator C12 by the gate G10. The maximum current can then be resumed to stabilize  $V_{OUT}$ .

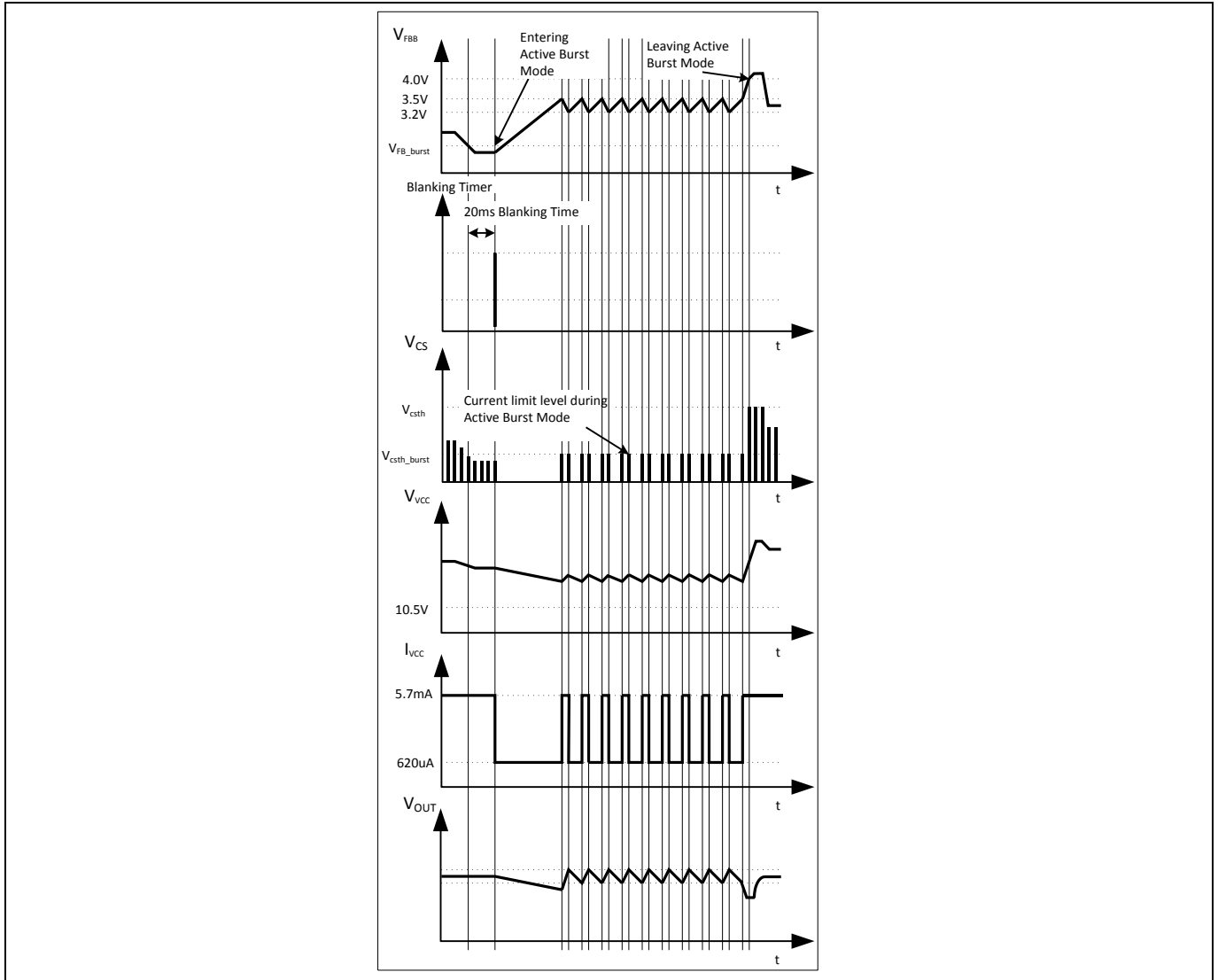

Figure 27 Signals in Active Burst Mode

### 3.7.3 Protection Modes

The IC provides Auto Restart mode as the major protection feature. Auto Restart mode can prevent the SMPS from destructive states. There are four kinds of auto restart mode; auto restart mode, non switch auto restart mode, odd skip auto restart mode and odd skip non switch auto restart mode.

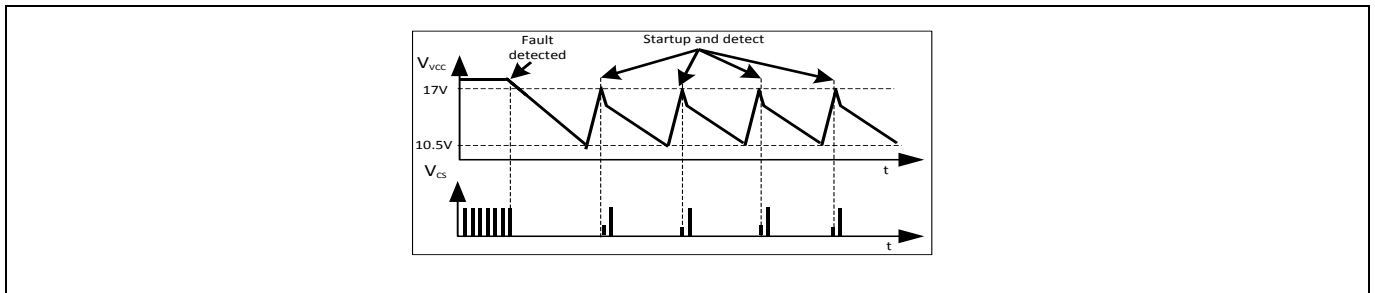
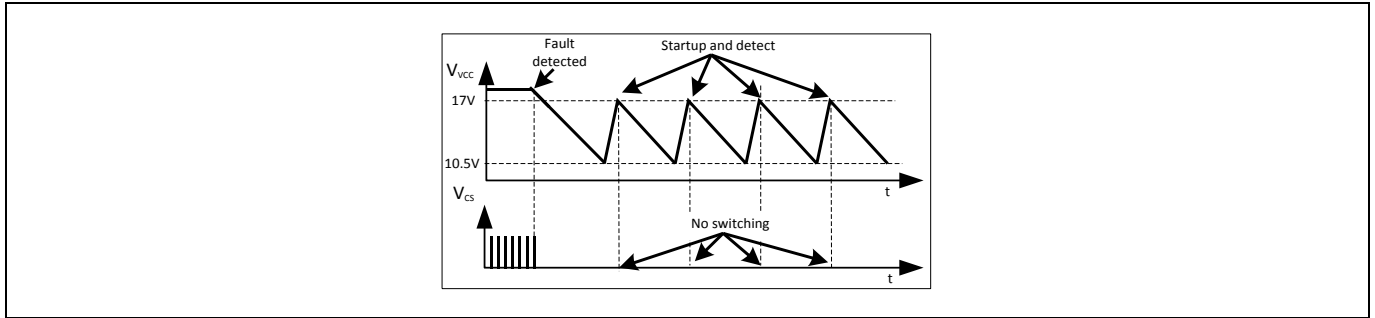
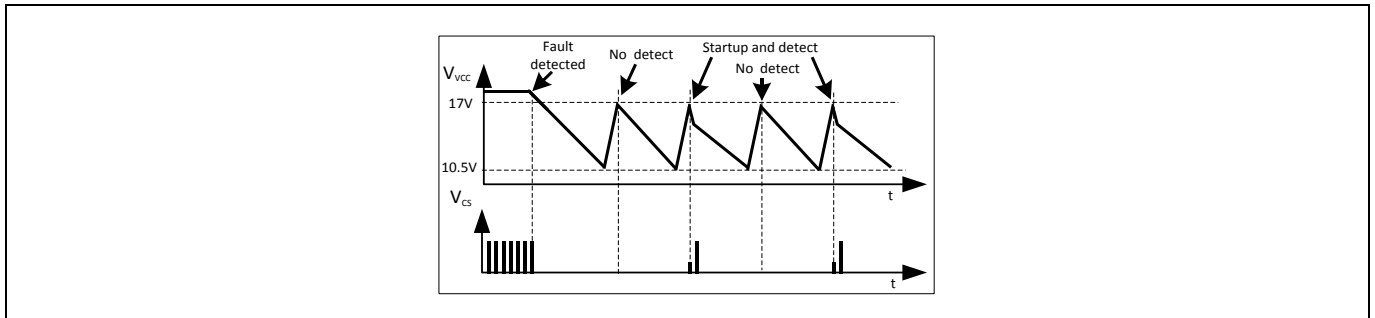

Figure 28 Auto restart waveform



**Figure 29 Non switch auto restart waveform**

The main purpose of the odd skip auto restart is to extend the restart time such that the power loss during auto restart protection can be reduced. This feature is particularly good for smaller VCC capacitor where the restart time is shorter. There is no detecting of fault and no switching pulse for the odd number restart cycle. At the even number of restart cycle the fault detect and soft start switching pulses maintained. If the fault persists, it would continue the auto-restart mode. However, if the fault is removed, it can release to normal operation only at the even number auto restart cycle (Figure 29).



**Figure 30 Odd skip auto restart waveform**

Odd skip non switch auto restart mode is similar to odd skip auto restart mode except the start up switching pulses are also suppressed at the even number of the restart cycle. The detection of fault still remains at the even number of the restart cycle. When the fault is removed, the IC will resume to normal operation at the even number of the restart cycle (Figure 30).

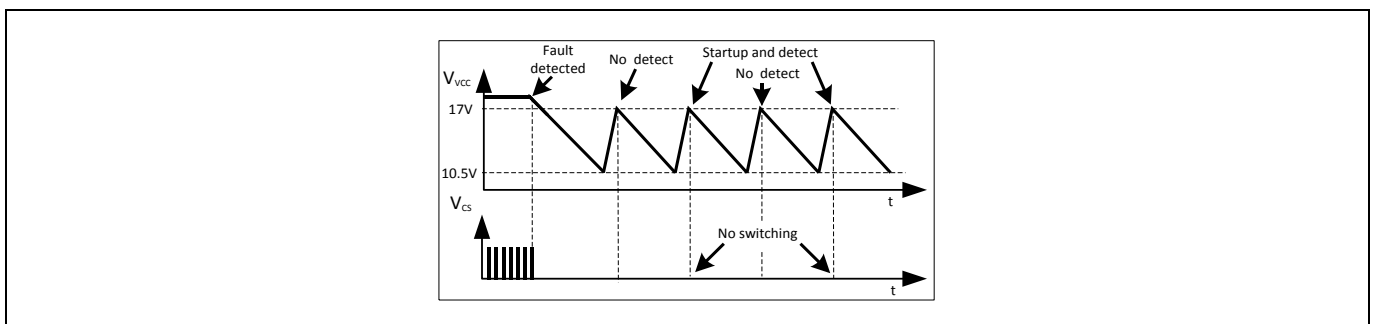

**Figure 31 Odd skip non switch auto restart waveform**

The following table list down the protection modes of the CoolSET™.

**Table 3 Protection functions**

Protection function	Failure condition	Protection Mode
VCC Overvoltage	1. $V_{CC} > 20.5\text{ V}$ and $F_B > 4.5\text{ V}$ & during soft start period 2. $V_{CC} > 25.5\text{ V}$	Odd skip Auto Restart
Overtemperature (controller junction)	$T_J > 130^\circ\text{C}$	Odd skip Auto Restart
Overload / Open loop	$V_{FBB} > 4.5\text{ V}$ , last for 20 ms and extended blanking time (extended blanking time counted as 256 times of $V_{BBA}$ charging and discharging from 0.9 V to 4.5V)	Odd skip Auto Restart
Vcc Undervoltage / Short Optocoupler	$V_{CC} < 10.5\text{ V}$	Auto Restart
Overtemperature (controller junction)	$T_J > 130^\circ\text{C}$	Odd skip non switch Auto Restart
External protection enable	$V_{AE} < 0.4\text{ V}$	Non switch Auto Restart
Brownout	$V_{BO\_ref} < 0.9\text{ V}$ and last for 30 ~ 60 $\mu\text{s}$	Non switch Auto Restart

### 3.7.3.1 VCC OVP, OTP and VCC under voltage

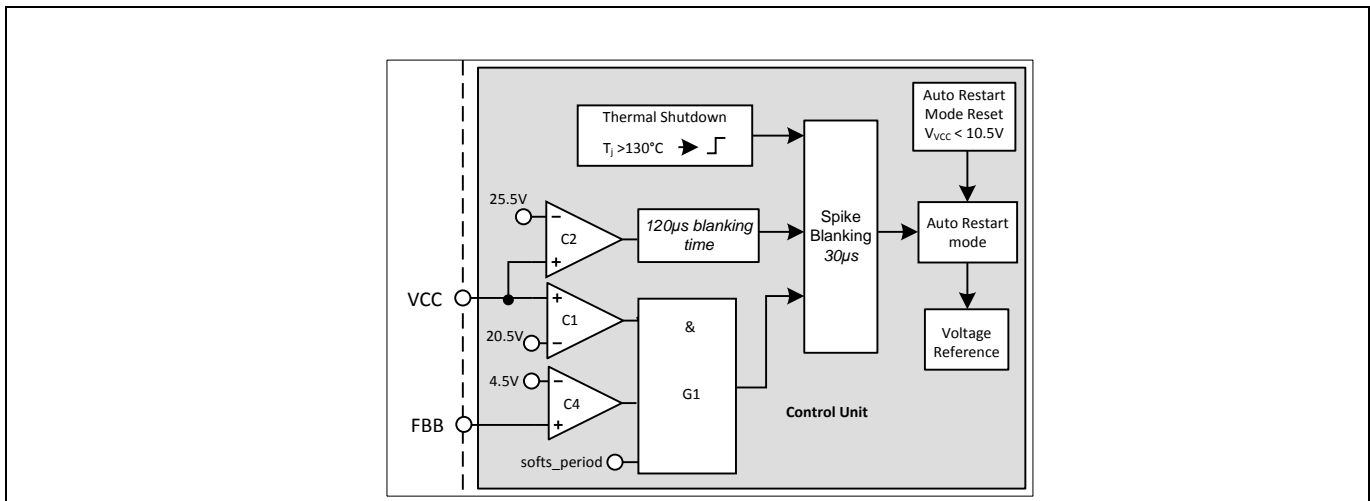

**Figure 32 Vcc OVP and OTP**

There are 2 types of VCC over voltage protection; VCC OVP (1) and VCC OVP (2). The VCC OVP (1) takes action only during the soft start period. The VCC OVP (2) takes the action in any conditions.

VCC OVP (1) condition is when  $V_{VCC}$  voltage is  $> 20.5\text{ V}$ ,  $V_{FBB}$  voltage is  $> 4.5\text{ V}$  and during soft start period, the IC enters into odd skip Auto Restart Mode. This condition likely happens during start up at open loop fault (Figure 30).

Vcc OVP (2) condition is when  $V_{VCC}$  voltage is  $> 25.5\text{ V}$ , the IC enters into odd skip Auto Restart Mode (Figure 30).

The over temperature protection OTP is sensed inside the controller IC. The Thermal Shutdown block keeps on monitoring the junction temperature of the controller. After detecting a junction temperature higher than

130°C, the IC will enter into the odd skip non switch Auto Restart mode. The ICE3AR4780JG has also implemented with a 50°C hysteresis. That means the IC can only be recovered when the controller junction temperature is dropped 50°C lower than the over temperature trigger point (Figure 31).

The VCC undervoltage and short opto-coupler will go into the normal auto restart mode inherently.

In case of VCC undervoltage, the Vcc voltage drops indefinitely. When it drops below the Vcc under voltage lock out “OFF” voltage (10.5 V), the IC will turn off the IC and the startup cell will turn on again. Then the Vcc voltage will be charged up to UVLO “ON” voltage (17 V) and the IC turns on again provided the startup cell charge up current is not drained by the fault. If the fault is not removed, the Vcc will continue to drop until it hits UVLO “OFF” voltage and the restart cycle repeats.

Short Optocoupler can lead to VCC undervoltage because once the opto-coupler (transistor side) is shorted, the feedback voltage will drop to zero and there will be no switching pulse. Then the VCC voltage will drop same as the VCC undervoltage.

### 3.7.3.2 Over load, open loop protection

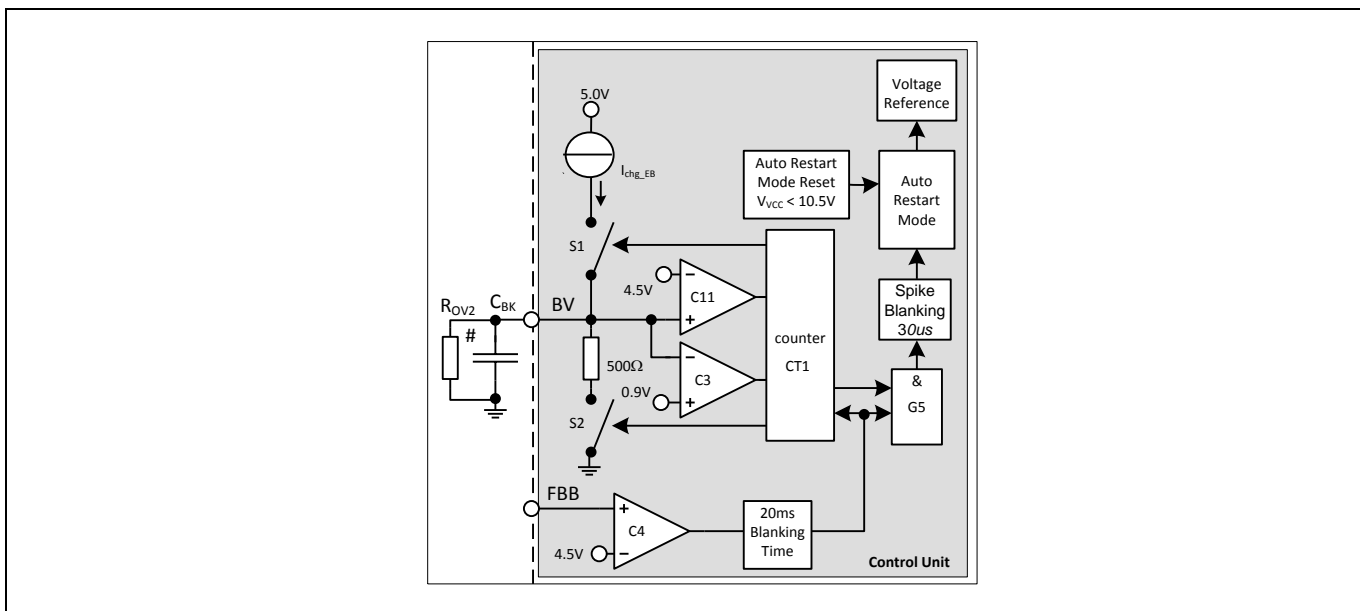

Figure 33 Over load, open loop protection

In case of Overload or Open Loop, the  $V_{FBV}$  voltage exceeds 4.5 V which will be observed by comparator C4. Then the built-in blanking time counter starts to count. When it reaches 20 ms, the extended blanking time counter CT1 is activated. The switch S2 is turned on and the voltage at the BBA pin will be discharged through 500 Ω resistor. When it drops to 0.9 V, the switch S2 is turned off and the Switch S1 is turned on. Then a constant current source  $I_{chg\_EB}$  will start to charge up BBA pin. When the voltage hits 4.5 V which is monitored by comparator C11, the switch S1 is turned off and the count will increase by 1. Then the switch S2 will turn on again and the voltage will drop to 0.9 V and rise to 4.5 V again. The count will then increase by 1 again. When the total count reaches 256, the counter CT1 will stop and it will release a high output signal. When both the input signals at AND gate G5 is high, the odd skip Auto Restart Mode is activated after the 30 µs spike blanking time (Figure 30).

The total blanking time depends on the addition of the built-in and the extended blanking time. If there is no CBK capacitor at BBA pin, the count will finish within 0.1 ms and the equivalent blanking time is just the built-in time of 20 ms. However, if the  $C_{BK}$  capacitor is big enough, it can be as long as 1 s. If  $C_{BK}$  is 0.1 µF and  $I_{chg\_EB}$  is 720 µA, the extendable blanking time is around 148.6 ms and the total blanking time is 168.6 ms.

Since the BBA pin is a multi-function pin, it would share with different functions. The resistor  $R_{B02}$  from brownout feature application may however affect the extendable blanking time (Figure 33). Thus it should take the  $R_{B02}$  into the calculation of the extendable blanking time. For example the extended blanking time would be changed (159.6~191.2 ms) with different resistance values of  $R_{B02}$  resistor. Table 4 shows some examples of  $C_{BK}$ ,  $R_{B02}$  vs blanking time.

**Table 4 Blanking time vs  $C_{BK}$  and  $R_{B02}$**

$C_{BK}$	$R_{B02}$	Extended blanking time	Overall blanking time
0.1 $\mu$ F	15 k $\Omega$	191.2 ms	211.2 ms
0.1 $\mu$ F	37.5 k $\Omega$	162.8 ms	182.8 ms
0.1 $\mu$ F	47 k $\Omega$	159.6 ms	179.6 ms

Note:  $R_{B02}$  must be always  $\geq 15$  k $\Omega$  in enable brownout mode, otherwise overload protection may not work.

### 3.7.4 Brown out Mode

When the AC input voltage is removed, the voltage at the bulk capacitor will fall. When it reaches a point that the system is greater than the system allowed maximum power, the system may go into over load protection. However, this kind of protection is not welcome for some of the applications such as auxiliary power for PC/server system because the output is in hiccup mode due to over load protection (auto restart mode). The brownout mode is to eliminate this phenomenon. The IC will sense the input voltage through the bulk capacitor to the BBA pin by 2 potential divider resistors,  $R_{B01}$  and  $R_{B02}$  (Figure 34).

When the system is powered up, the bulk capacitor and the Vcc capacitor are charged up at the same time. When the VCC voltage is charged to > 7 V, the brownout circuit starts to operate (Figure 34). Since the UVLO is still at low level as the VCC voltage does not reach the 17 V UVLO “ON” voltage. The NAND gate G20 will release a low signal to the flip flop FF5 and the negative output of FF5 will release a high signal to turn on the switch S3. The constant load LD6 will start to draw constant current  $I_{chg\_BO}$  from the BBA pin. That means the brownout mode is default “ON” during the system starts up.

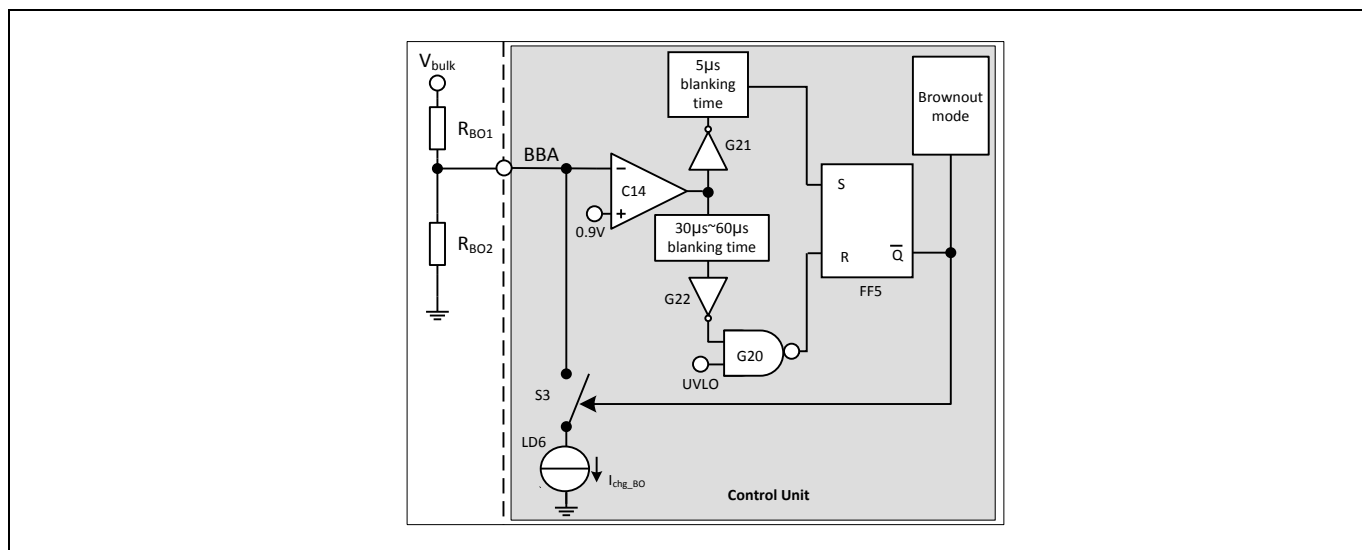

**Figure 34 Brown out detection circuit**

Once the system enters the brown out mode, there will be no switching pulse and the IC keeps on monitoring the BV signal. If the brown out signal is not reset, there is no switching pulse in each restart cycle (Figure 35).

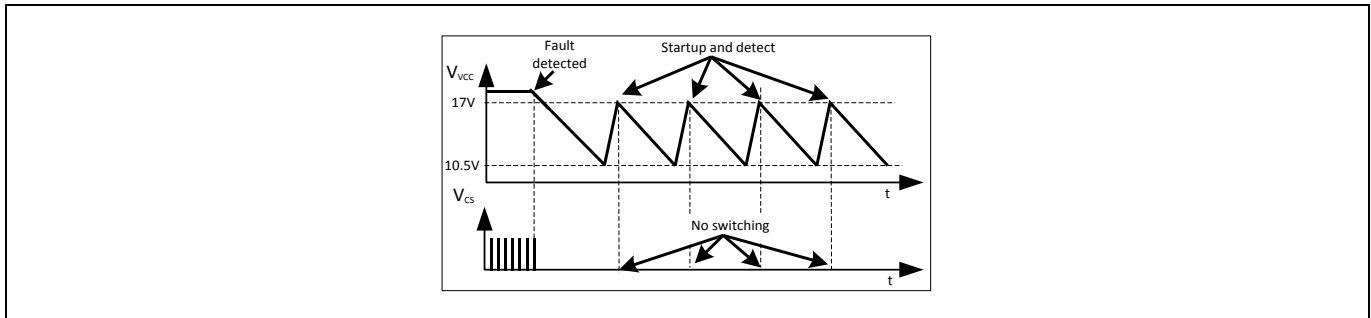

**Figure 35 Brown out mode waveform**

The voltage at bulk capacitor  $V_{bulk}$  continues to increase and so is the voltage at BBA. When the BBA voltage reaches 0.9 V, the output of OPAMP C14 will become low. Through the inverter gate G21, the “S” input of the flip flop FF5 is changed to high. Then the negative output of FF5 is low. The brownout mode is then “OFF” and the constant current load LD6 is also “OFF” through the turn-off of the S3. The system will turn on with soft start in the coming restart cycle when Vcc reaches the Vcc “ON” voltage 17 V.

When there is an input voltage drop, the BBA voltage also drops. When the voltage at BBA pin falls below 0.9 V, the output of OPAMP C14 is changed to high. The inverter gate G22 will change the high input to low output. Then the NAND gate G22 will have a high output. The negative output of the flip flop FF5 is then become high. The constant load LD6 is “ON” again and the IC enters the brownout mode where the Vcc swings between 10.5 V and 17 V without any switching pulse.

The formula to calculate the  $R_{BO1}$  and  $R_{BO2}$  are as below.

$$R_{BO1} = V_{hys} / I_{chg\_BO}$$

$$R_{BO2} = V_{ref\_BO} * R_{BO1} / (V_{BO\_l} - V_{ref\_BO})$$

where  $V_{BO\_l}$ : input brownout voltage (low point);  $V_{hys}$ : input brownout hysteresis voltage;  $V_{ref\_BO}$ : IC reference voltage for brownout;  $R_{BO1}$  and  $R_{BO2}$ : resistors divider from input voltage to BBA pin

For example,

$$I_{chg\_BO} = 10 \mu A, V_{ref\_BO} = 0.9 V,$$

Case 1:

if brownout voltage is 70 V<sub>AC</sub> on and 100 V<sub>AC</sub> off,

then brownout voltage,  $V_{BO\_l} = 100 V_{DC}$ ,

hysteresis voltage,  $V_{BO\_hys} = 43 V_{DC}$ ,

$$R_{BO1} = 4.3 M\Omega, R_{BO2} = 39 k\Omega$$

Case 2:

if brownout voltage is 100 V<sub>AC</sub> on and 120 V<sub>AC</sub> off,

then brownout voltage,  $V_{BO\_l} = 141 V_{DC}$ ,

hysteresis voltage,  $V_{BO\_hys} = 28 V_{DC}$ ,

$$R_{BO1} = 2.8 M\Omega, R_{BO2} = 18 k\Omega$$

Case 3:

if brownout voltage is 120 V<sub>AC</sub> on and 160 V<sub>AC</sub> off,

then brownout voltage,  $V_{BO\_l}=169 V_{DC}$ ,

hysteresis voltage,  $V_{BO\_hys}=56 V_{DC}$ ,

$R_{BO1}=5.6 M\Omega$ ,  $R_{BO2}=30 k\Omega$

The summary is listed below.

**Table 5 Brownout resistors vs  $V_{BO\_hys}$**

Case	$V_{BO\_l}$	$V_{BO\_h}$	$V_{BO\_hys}$	$R_{BO1}$	$R_{BO2}$
1	100V	143V	43V	4.3M $\Omega$	39K $\Omega$
2	141V	169V	28V	2.8M $\Omega$	18K $\Omega$
3	169V	225V	56V	5.6M $\Omega$	30K $\Omega$

*Note: The above calculation assumes the tapping point (bulk capacitor) has a stable voltage with no ripple voltage. If there is ripple in the input voltage, it should take the highest voltage for the calculation;  $V_{BO\_l}$  + ripple voltage. Besides that the low side brownout voltage  $V_{BO\_l}$  added with the ripple voltage at the tapping point should always be lower than the high side brownout voltage ( $V_{BO\_h}$ );  $V_{BO\_h} > V_{BO\_l}$  + ripple voltage. Otherwise, the brownout feature cannot work properly. In short, when there is a high load running in system before entering brownout, the input ripple voltage will increase and the brownout voltage will increase ( $V_{BO\_l} = V_{BO\_l}$  + ripple voltage) at the same time. If the  $V_{BO\_hys}$  is set too small and is close to the ripple voltage, then the brownout feature cannot work properly ( $V_{BO\_l} = V_{BO\_h}$ ).*

If the brownout feature is not needed, it needs to tie the BBA pin to the Vcc pin through a current limiting resistor, 500 k $\Omega$ ~1 M $\Omega$ . The BBA pin cannot be in floating condition. If the brownout feature is disabled with a tie up resistor, there is a limitation of the capacitor  $C_{BK}$  at the BBA pin. It is as below.

**Table 6 VCC tie up resistor and  $C_{BK\_max}$**

	VCC tie up resistor	$C_{BK\_max}$
1	500 k $\Omega$	0.47 $\mu$ F
2	1 M $\Omega$	0.22 $\mu$ F

### 3.7.5 Action sequence at BBA pin

Since there are 3 functions at the same BBA pin; brownout, extended blanking time and the auto-restart enable, the actions of sequence are set as per the below table in case of several features happens simultaneously.

**Table 7 Action sequence at BBA pin**

$2^{nd}$ \ $1^{st}$	Auto-restart enable	Extended blanking time	Brownout
Auto-restart enable	Auto-restart enable	Auto-restart enable	Brownout
Extended blanking time	Auto-restart enable	Extended blanking time	Brownout
Brownout	Auto-restart enable	Extended blanking time	Brownout

The top row of the table is the first happened feature and the left column is the second happened feature. For example,

Case 1:

The “Auto-restart enable” feature happened first and it follows with the “Extended blanking time” feature. Then the “Auto-restart enable” feature will continue to hold and the “Extended blanking time” feature is ignored.

Case 2:

The “Extended blanking time” feature happened first and it follows with the “Auto-restart enable” feature. Then the “Auto-restart enable” feature will take the priority and the “Extended blanking time” feature is overridden.

Case 3:

The “Extended blanking time” feature happened first and it follows with the “Brownout” feature. Then the “Extended blanking time” feature will continue to work until it ends. After that if the over load fault is removed the “Brownout” feature takes the action.

Case 4:

The “Brownout” feature happened first and it follows with the “Auto-restart enable” feature. Then the “Brownout” feature will continue to work and the “Auto-restart enable” feature is ignored.

One typical case happened is that the “Extended blanking time” feature happened first and it follows with the “Brownout” feature. If, however, the over load fault is removed before the end of the extended blanking time, the “Brownout” feature can take action only after 20 ms buffer time.

## 4 Electrical Characteristics

Note: All voltages are measured with respect to ground (Pin 12). The voltage levels are valid if other ratings are not violated.

### 4.1 Absolute Maximum Ratings

Note: Absolute maximum ratings are defined as ratings, which when being exceeded may lead to destruction of the integrated circuit. For the same reason make sure, that any capacitor that will be connected to pin 11 (VCC) is discharged before assembling the application circuit.  $T_o=25^{\circ}\text{C}$  unless otherwise specified.

**Table 8 Absolute Maximum Ratings**

Parameter	Symbol	Limit Values		Unit	Remarks
		min.	max.		
Drain Source Voltage	$V_{DS}$	-	800	V	
Pulse drain current, $t_p$ limited by $T_{jmax}$	$I_{D\_Puls}$	-	1.95	A	
Avalanche energy, repetitive $t_{AR}$ limited by max. $T_j=150^{\circ}\text{C}$ <sup>1</sup>	$E_{AR}$	-	0.024	mJ	
Avalanche current, repetitive $t_{AR}$ limited by max. $T_j=150^{\circ}\text{C}$	$I_{AR}$	-	0.95	A	
VCC Supply Voltage	$V_{VCC}$	-0.3	27	V	
FBB Voltage	$V_{FBB}$	-0.3	5.5	V	
BV Voltage	$V_{BV}$	-0.3	5.5	V	
CS Voltage	$V_{CS}$	-0.3	5.5	V	
Junction Temperature	$T_j$	-40	150	$^{\circ}\text{C}$	Controller & CoolMOST™
Storage Temperature	$T_s$	-55	150	$^{\circ}\text{C}$	
Thermal Resistance (Junction–Ambient)	$R_{thJA}$	-	110	K/W	
Soldering temperature, wavesoldering only allowed at leads	$T_{sold}$	-	260	$^{\circ}\text{C}$	1.6mm (0.063in.) from case for 10s
ESD Capability (incl. Drain Pin)	$V_{ESD}$	-	2	kV	Human body model <sup>2</sup>

<sup>1</sup> Repetitive avalanche causes additional power losses that can be calculated as  $P_{AV}=E_{AR} \cdot f$

<sup>2</sup> According to EIA/JESD22-A114-B (discharging a 100pF capacitor through a 1.5 kΩ series resistor)

## 4.2 Absolute Maximum Ratings

Note: Within the operating range the IC operates as described in the functional description.

**Table 9 Absolute Maximum Ratings**

Parameter	Symbol	Limit Values		Unit	Remarks
		min.	max.		
VCC Supply Voltage	$V_{VCC}$	$V_{VCCoff}$	25	V	Max value limited due to $V_{VCCOVp}$
Junction Temperature of Controller	$T_{jcon}$	-40	130	°C	Max value limited due to thermal shut down of controller
Junction Temperature of CoolMOS™	$T_{jcoolMOS}$	-40	150	°C	

## 4.3 Characteristics

### 4.3.1 Supply Section

Note: The electrical characteristics involve the spread of values within the specified supply voltage and junction temperature range  $T_J$  from  $-40\text{ °C}$  to  $125\text{ °C}$ . Typical values represent the median values, which are related to  $25\text{ °C}$ . If not otherwise stated, a supply voltage of  $V_{CC} = 17\text{ V}$  is assumed.

**Table 10 Supply Section**

Parameter	Symbol	Limit Values			Unit	Test Condition
		min.	typ.	max.		
Start Up Current	$I_{VCCstart}$	-	200	300	μ A	$V_{VCC} = 16\text{ V}$
VCC Charge Current	$I_{VCCcharge1}$	-	-	5.0	mA	$V_{VCC} = 0\text{ V}$
	$I_{VCCcharge2}$	0.55	0.9	1.60	mA	$V_{VCC} = 1\text{ V}$
	$I_{VCCcharge3}$	0.38	0.7	-	mA	$V_{VCC} = 16\text{ V}$
Leakage Current of Start Up Cell and CoolMOS™	$I_{startLeak}$	-	0.2	50	μ A	$V_{Drain} = 650\text{ V}$ at $T_J = 100\text{ °C}^1$
Supply Current with Inactive Gate	$I_{VCCsup1}$	-	1.9	3.2	mA	
Supply Current with Active Gate	$I_{VCCsup2}$	-	3.0	4.4	mA	$I_{FBB} = 0\text{ A}$
Supply Current in Auto Restart Mode with Inactive Gate	$I_{VCCrestart}$	-	320	-	μ A	$I_{FBB} = 0\text{ A}$
Supply Current in Active Burst Mode with Inactive Gate	$I_{VCCburst1}$	-	620	950	μ A	$V_{FBB} = 2.5\text{ V}$
	$I_{VCCburst2}$	-	620	950	μ A	$V_{VCC} = 11.5\text{ V}$ , $V_{FBB} = 2.5\text{ V}$
VCC Turn-On Threshold VCC Turn-Off Threshold VCC Turn-On/Off Hysteresis	$V_{VCCon}$	16.0	17.0	18.0	V	
	$V_{VCCoff}$	9.8	10.5	11.2	V	
	$V_{VCChys}$	-	6.5	-	V	

<sup>1</sup> The parameter is not subjected to production test - verified by design/characterization

### 4.3.2 Internal Voltage Reference

**Table 11 Internal Voltage Reference**

Parameter	Symbol	Limit Values			Unit	Test Condition
		min.	typ.	max.		
Trimmed Reference Voltage	V <sub>REF</sub>	4.90	5.00	5.10	V	measured at pin FBB I <sub>FBB</sub> = 0

### 4.3.3 PWM Section

**Table 12 PWM Section**

Parameter	Symbol	Limit Values			Unit	Test Condition
		min.	typ.	max.		
Fixed Oscillator Frequency	f <sub>OSC1</sub>	87	100	113	kHz	
	f <sub>OSC2</sub>	90	100	108	kHz	T <sub>j</sub> = 25°C
Frequency Jittering Range	f <sub>jitter</sub>	-	±4.0	-	kHz	T <sub>j</sub> = 25°C
Frequency Jittering period	T <sub>jitter</sub>	-	4.0	-	ms	T <sub>j</sub> = 25°C
Max. Duty Cycle	D <sub>TRx</sub>	0.70	0.75	0.80		
Min. Duty Cycle	D <sub>min</sub>	0	-	-		V <sub>FBB</sub> < 0.3 V
PWM-OP Gain	A <sub>V</sub>	3.05	3.25	3.45		
Voltage Ramp Offset	V <sub>Offset-Ramp</sub>	-	0.60	-	V	
V <sub>FBB</sub> Operating Range Min Level	V <sub>FBmin</sub>	-	0.7	-	V	
V <sub>FBB</sub> Operating Range Max level	V <sub>FBmax</sub>	-	-	4.3	V	CS=1 V, limited by Comparator C4 <sup>1</sup>
FBB Pull-Up Resistor	R <sub>FB</sub>	9.0	15.4	23.0	k Ω	

### 4.3.4 Soft Start time

**Table 13 Soft Start time**

Parameter	Symbol	Limit Values			Unit	Test Condition
		min.	typ.	max.		
Soft Start time	t <sub>SS</sub>	-	10	-	ms	

<sup>1</sup> The parameter is not subjected to production test - verified by design/characterization

### 4.3.5 Control Unit

**Table 14 Control Unit**

Parameter		Symbol	Limit Values			Unit	Test Condition
			min.	typ.	max.		
Brown out reference voltage for comparator C14		V <sub>BO_ref</sub>	0.8	0.9	1.0	V	
Blanking time voltage lower limit for Comparator C3		V <sub>BKC3</sub>	0.80	0.90	1.00	V	
Blanking time voltage upper limit for Comparator C11		V <sub>BKC11</sub>	4.28	4.50	4.72	V	
Over Load Limit for Comparator C4		V <sub>FBC4</sub>	4.28	4.50	4.72	V	
Entry Burst select High level for Comparator C19		V <sub>FBC19</sub>	4.28	4.50	4.72	V	
Entry Burst select Low level for Comparator C20		V <sub>FBC20</sub>	0.40	0.50	0.60	V	
Active Burst Mode Entry Level for Comparator C5	10% Pin_max	V <sub>FB_burst1</sub>	1.51	1.60	1.69	V	< 7 counts
	6.67%	V <sub>FB_burst2</sub>	1.34	1.42	1.50	V	8 ~ 39 counts
	4.38%	V <sub>FB_burst3</sub>	1.20	1.27	1.34	V	40 ~ 191 counts
Active Burst Mode High Level for Comparator C6a		V <sub>FBC6a</sub>	3.35	3.50	3.65	V	In Active Burst Mode
Active Burst Mode Low Level for Comparator C6b		V <sub>FBC6b</sub>	3.06	3.20	3.34	V	
Active Burst Mode Level for Comparator C13		V <sub>FBC13</sub>	3.85	4.00	4.15	V	
Overvoltage Detection Limit for Comparator C1		V <sub>VCCOVP1</sub>	19.5	20.5	21.5	V	V <sub>FBB</sub> = 5V, during soft start
Overvoltage Detection Limit for Comparator C2		V <sub>VCCOVP2</sub>	25.0	25.5	26.3	V	
Auto-restart enable reference voltage for Comparator C9		V <sub>AE</sub>	0.25	0.40	0.45	V	
Charging current for extended blanking time		I <sub>chg_EB</sub>	460	720	864	μA	
Charging current for brownout		I <sub>chg_BO</sub>	9.0	10.0	10.08	μA	
Thermal Shutdown <sup>1</sup>		T <sub>JSD</sub>	130	140	150	°C	Controller
Hysteresis for thermal Shutdown <sup>1</sup>		T <sub>JSD_hys</sub>	-	50	-	°C	
Built-in Blanking Time for Overload Protection or enter Active Burst Mode		t <sub>BK</sub>	-	20	-	ms	
Timer for entry burst select		t <sub>EBS</sub>	-	1	-	ms	
Spike Blanking Time for Auto-Restart Protection		t <sub>Spike</sub>	-	30	-	μs	

*Note: The trend of all the voltage levels in the Control Unit is the same regarding the deviation except V<sub>VCCOVP</sub> and V<sub>VCCPD</sub>*

<sup>1</sup> The parameter is not subject to production test - verified by design/characterization. The thermal shutdown temperature refers to the junction temperature of the controller.

### 4.3.6 Current Limiting

**Table 15 Current Limiting**

Parameter		Symbol	Limit Values			Unit	Test Condition
			min.	typ.	max.		
Peak Current Limitation (incl. Propagation Delay)		$V_{csth}$	0.98	1.06	1.13	V	$dV_{sense} / dt = 0.6V/\mu s$ (Figure 21)
Peak Current Limitation during Active Burst Mode	20% Pin_max	$V_{csth\_burst1}$	0.37	0.45	0.51	V	< 7 counts
	13.3%	$V_{csth\_burst2}$	0.30	0.37	0.44	V	8 ~ 39 counts
	9.6% Pin_max	$V_{csth\_burst3}$	0.23	0.31	0.37	V	40 ~ 191 counts
Leading Edge Blanking	Normal mode	$t_{LEB\_normal}$	-	220	-	ns	
	Burst mode	$t_{LEB\_burst}$	-	180	-	ns	
CS Input Bias Current		$I_{CSbias}$	-1.5	-0.2	-	$\mu A$	$V_{CS} = 0V$

### 4.3.7 CoolMOS™ Section

**Table 16 CoolMOS™ Section**

Parameter		Symbol	Limit Values			Unit	Test Condition
			min.	typ.	max.		
Drain Source Breakdown Voltage		$V_{(BR)DSS}$	800	-	-	V	$T_j = 25^\circ C$
			870	-	-	V	$T_j = 110^\circ C^1$
Drain Source On-Resistance		$R_{DSon}$	-	4.70	5.18	$\Omega$	$T_j = 25^\circ C$
			-	10.45	11.50	$\Omega$	$T_j = 125^\circ C^1$
			-	12.76	14.04	$\Omega$	$T_j = 150^\circ C^1$ at $I_D = 0.58 A$
Effective output capacitance, energy related		$C_{o(er)}$	-	7.2	-	pF	$V_{DS} = 0 V$ to 480 V
Rise Time <sup>2</sup>		$t_{rise}$	-	30	-	ns	
Fall Time <sup>2</sup>		$t_{fall}$	-	30	-	ns	

<sup>1</sup> The parameter is not subjected to production test - verified by design/characterization

<sup>2</sup> Measured in a Typical Flyback Converter Application

## 5 CoolMOS™ Performance Characteristics

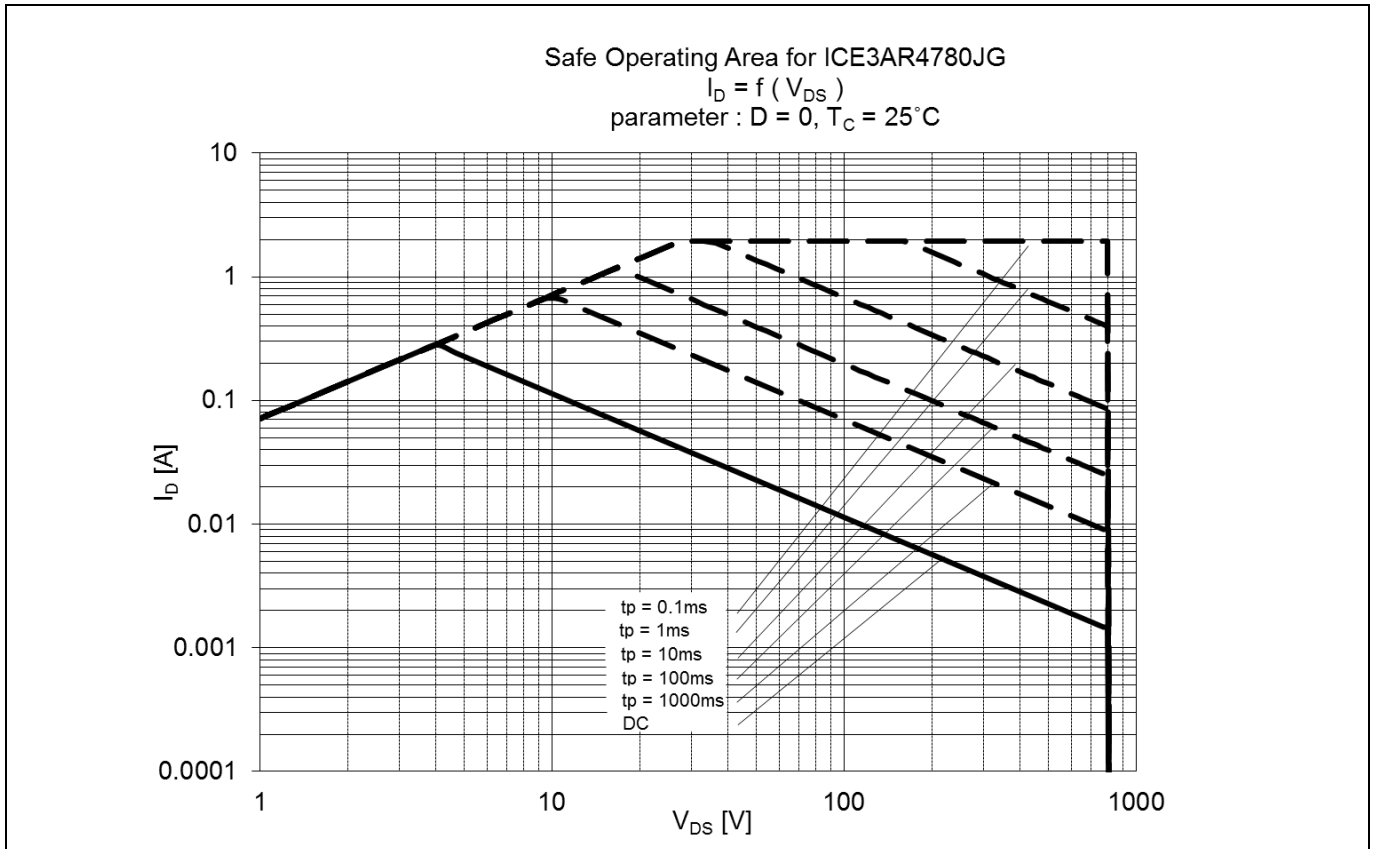

**Figure 36** Safe Operating Area (SOA) curve for ICE3AR4780JG

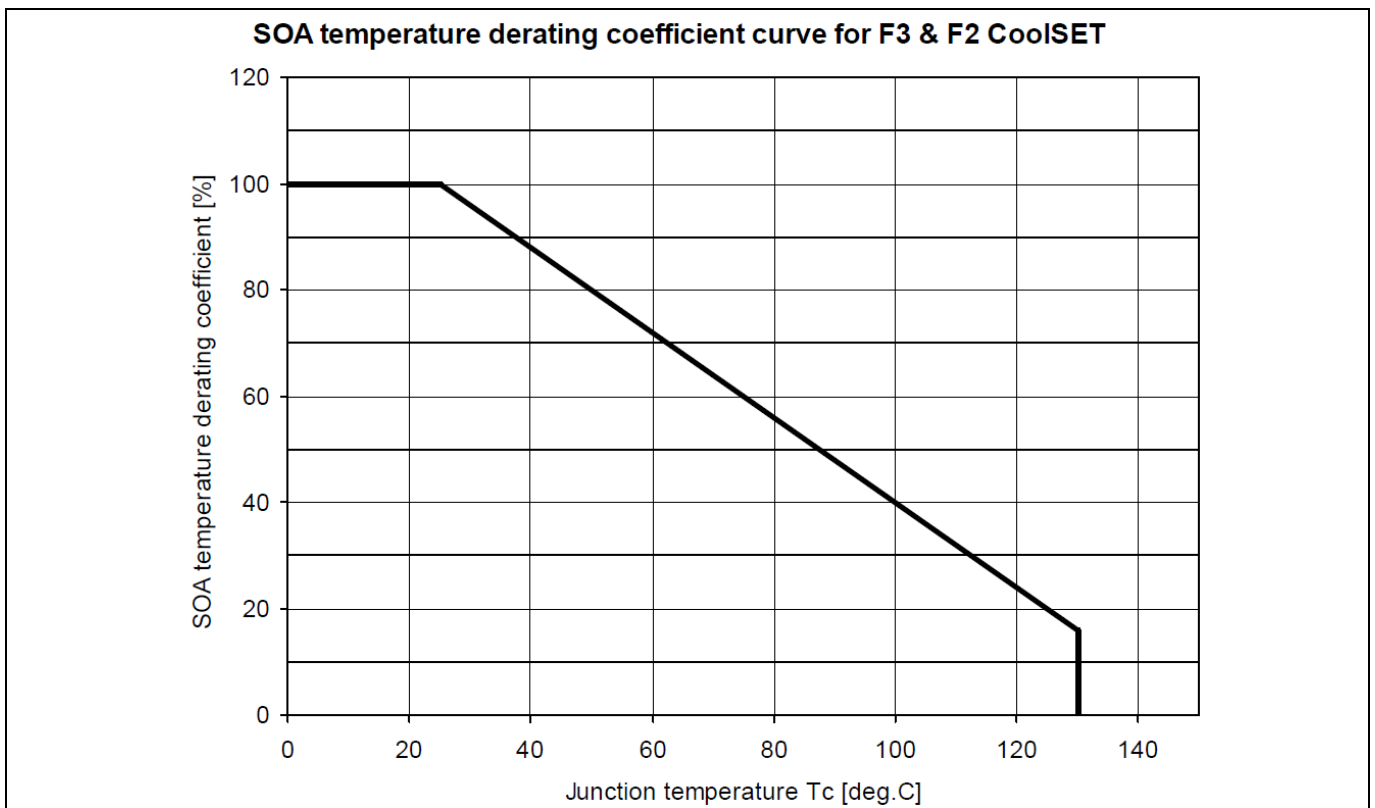

**Figure 37** SOA temperature derating coefficient curve

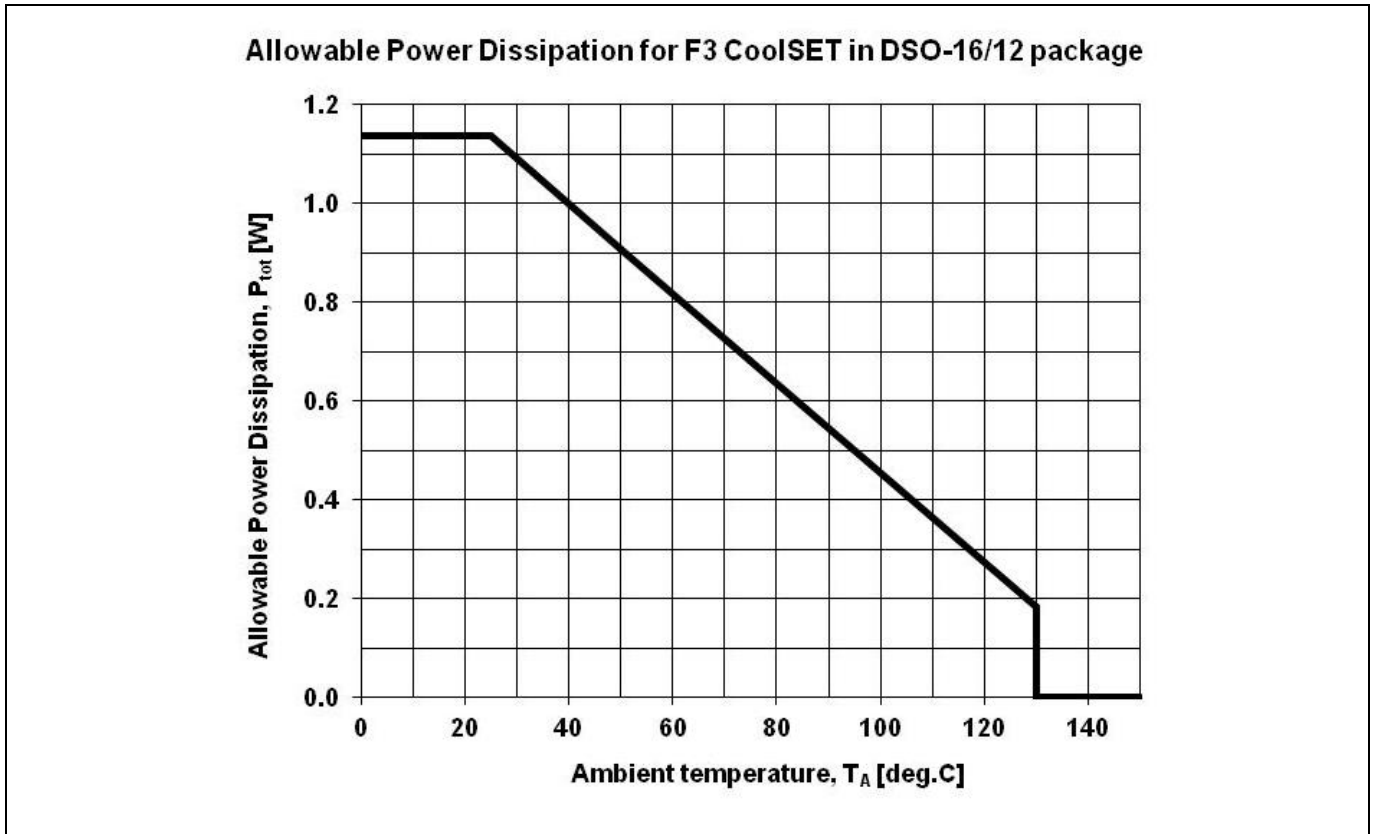

Figure 38 Power dissipation;  $P_{tot}=f(T_a)$

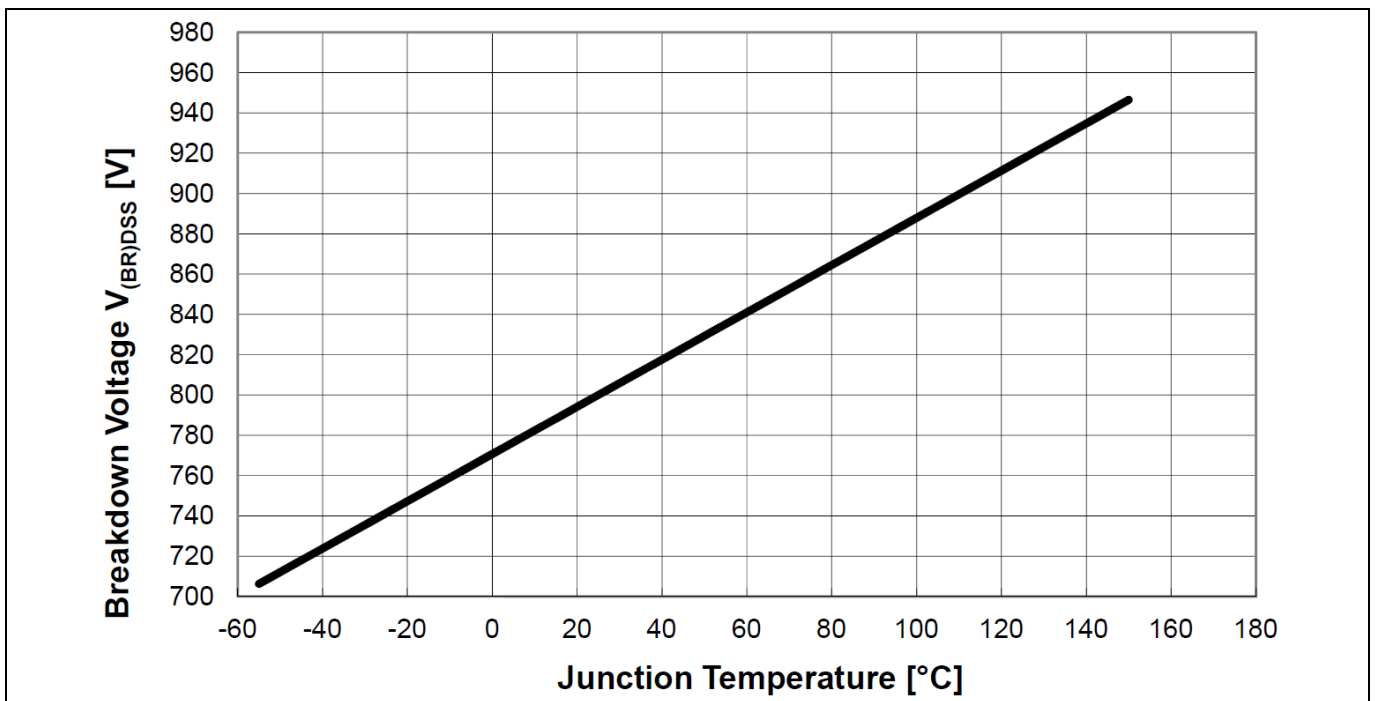

Figure 39 Drain-source breakdown voltage;  $V_{BR(DSS)}=f(T_j)$ ,  $I_D=0.25mA$

## 6 Input Power Curve

Two input power curves giving the typical input power versus ambient temperature are showed below;  $V_{IN}=85 V_{AC} \sim 265 V_{AC}$  (Figure 40) and  $V_{IN}=230 V_{AC} \pm 15\%$  (Figure 41). The curves are derived based on a typical discontinuous mode flyback model which considers either 50% maximum duty ratio or 100 V maximum secondary to primary reflected voltage (higher priority). The calculation is based on no copper area as heatsink for the device. The input power already includes the power loss at input common mode choke, bridge rectifier and the CoolMOS™. The device saturation current ( $I_{D\_Puls}$  @  $T_j=125^\circ C$ ) is also considered.

To estimate the output power of the device, it is simply multiplying the input power at a particular operating ambient temperature with the estimated efficiency for the application. For example, a wide range input voltage (Figure 41), operating temperature is  $50^\circ C$ , estimated efficiency is 85%, then the estimated output power is 16.15 W ( $19 W * 85\%$ ).

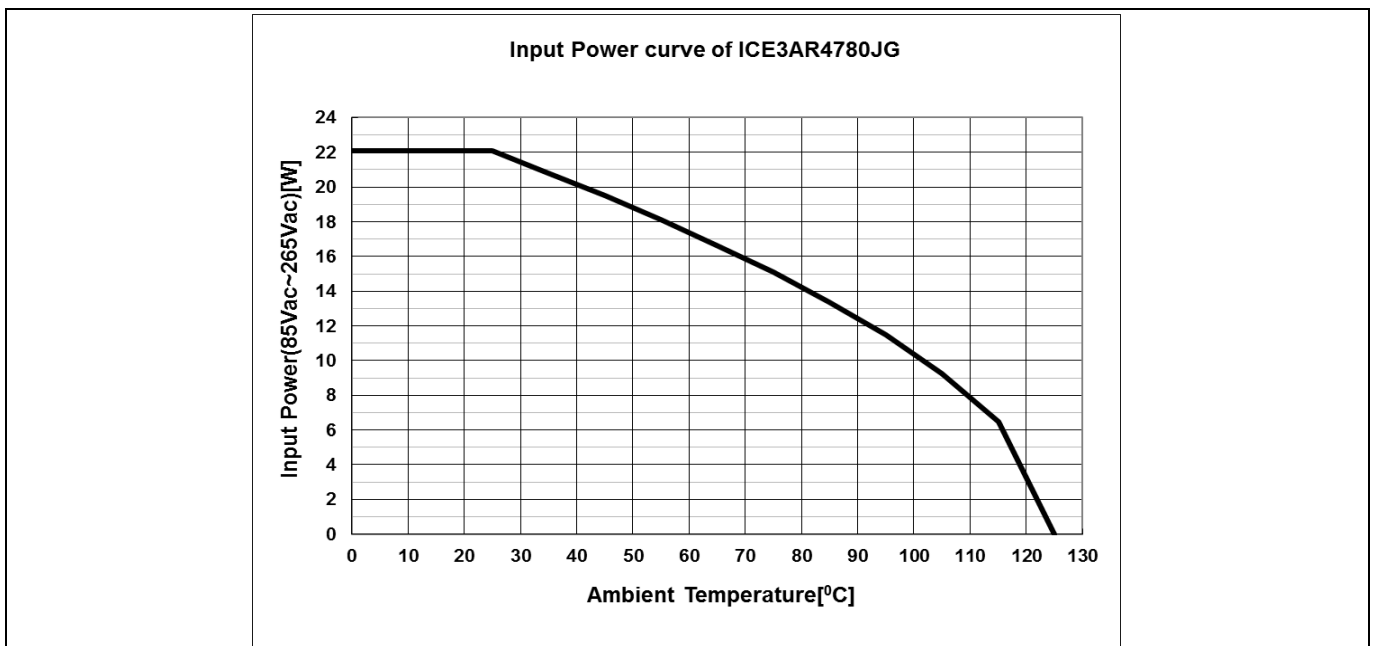

Figure 40 Input power curve  $V_{IN}=85 \sim 265 V_{AC}$ ;  $P_{in}=f(T_a)$

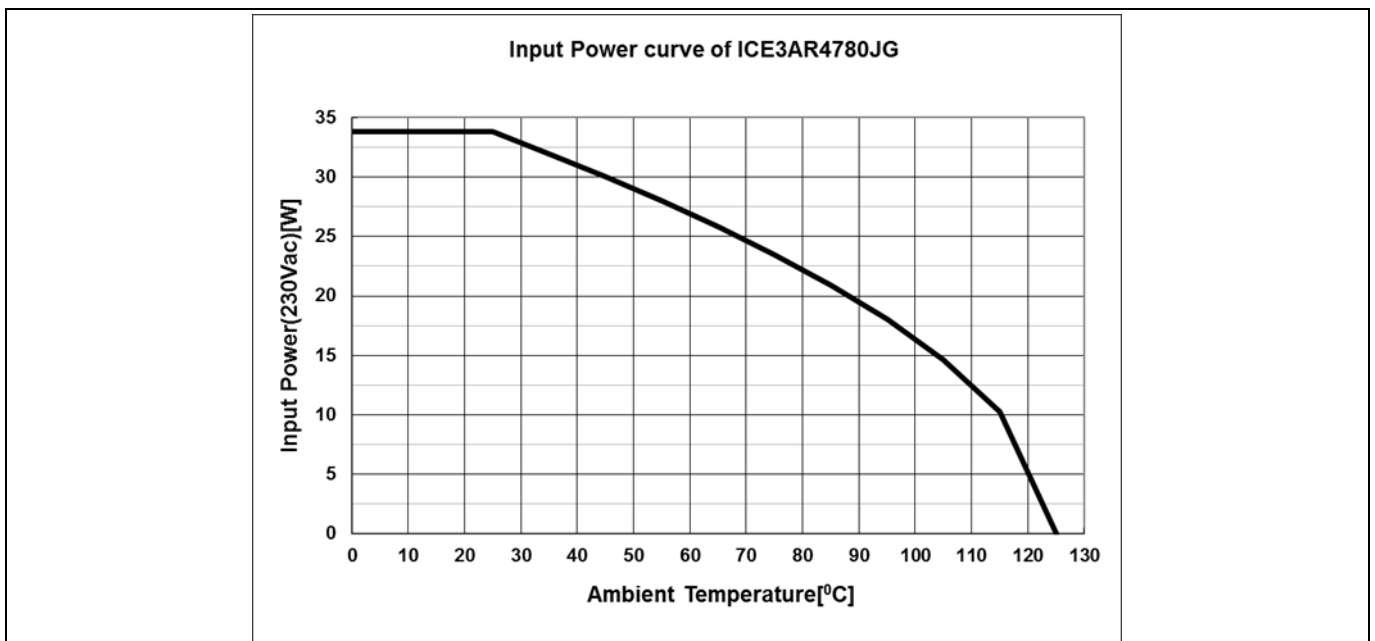

Figure 41 Input power curve  $V_{IN}=230 V_{AC}$ ;  $P_{in}=f(T_a)$

## 7 Outline Dimension

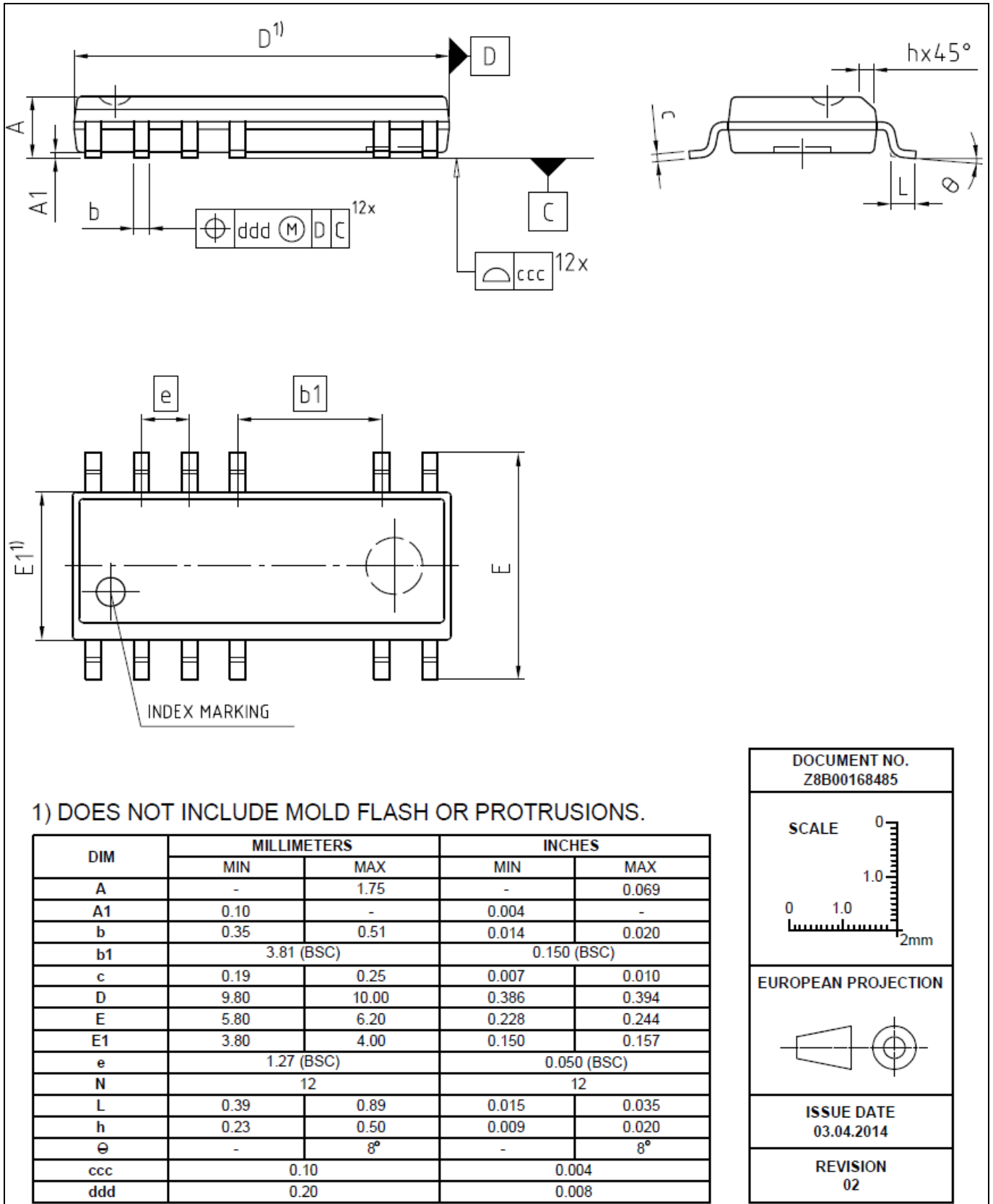

Figure 42 PG-DSO-12 (Pb-free lead plating Plastic Dual-in-Line Outline)

## 8 Marking

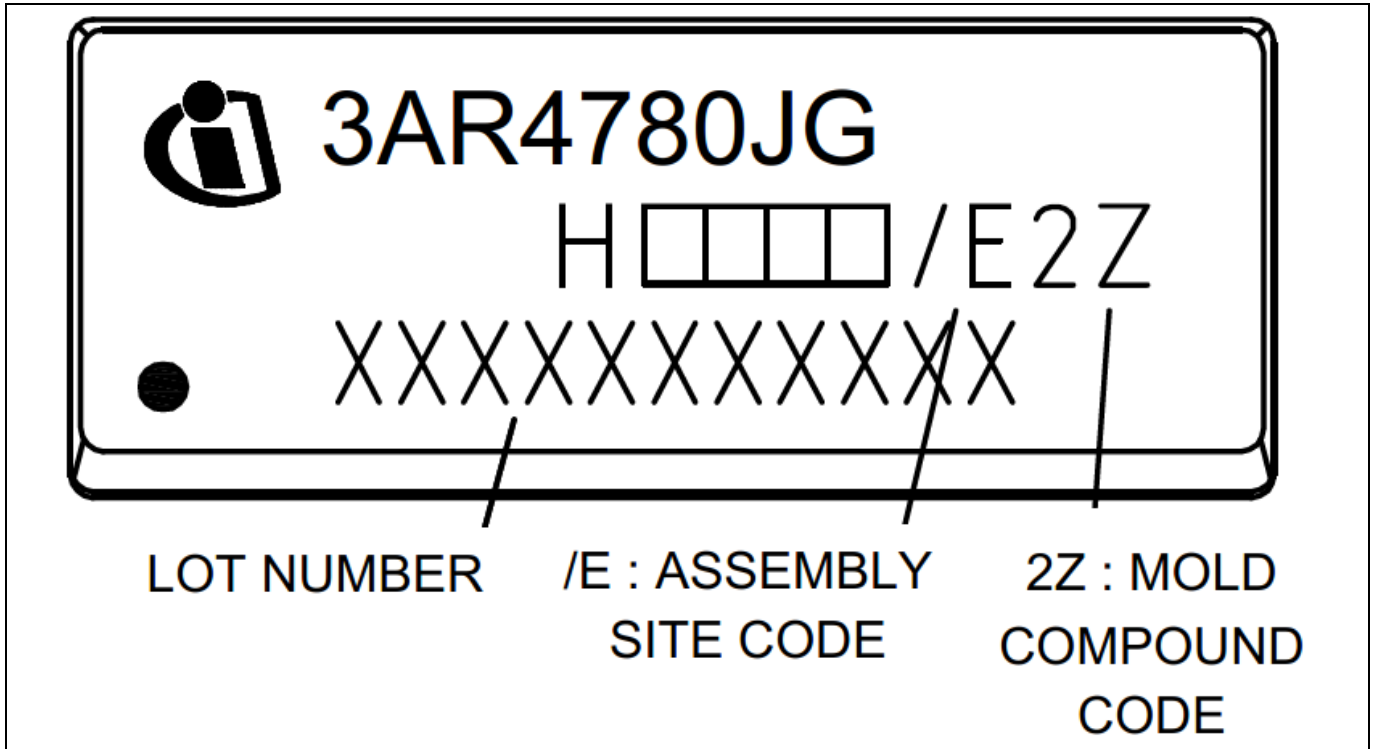
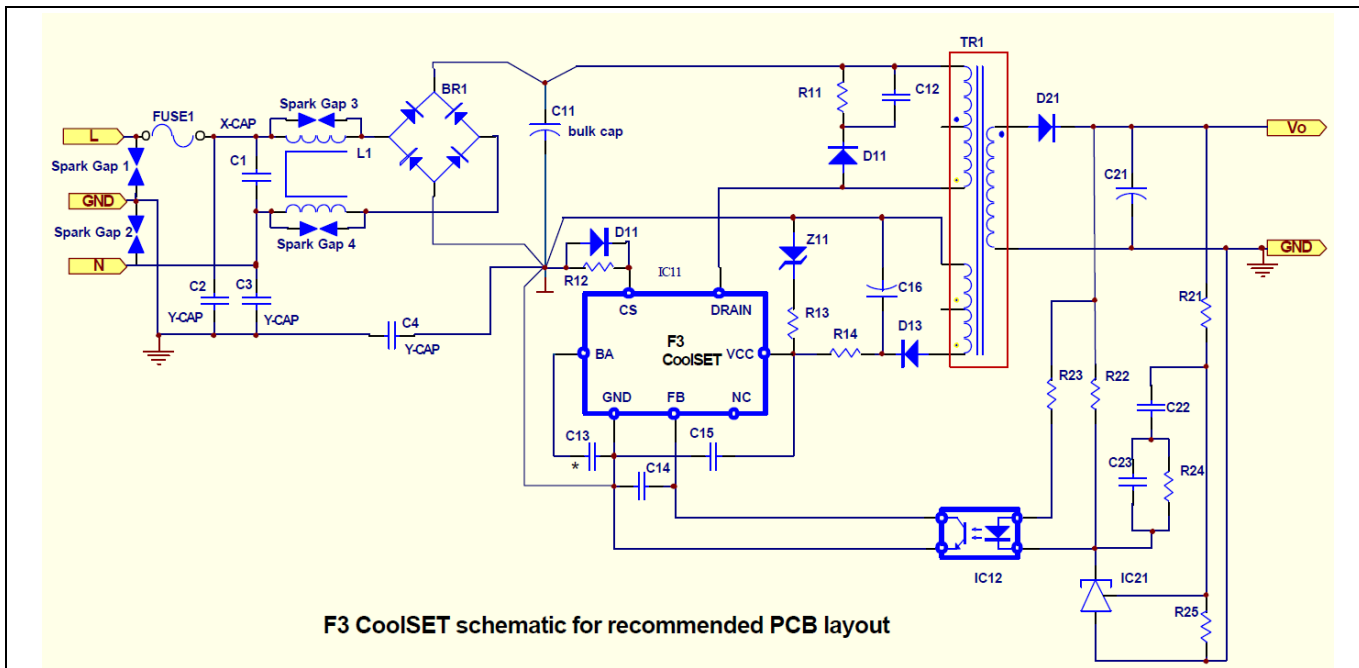

Figure 43 Marking for ICE3AR4780JG

## 9 Schematic for recommended PCB layout



**Figure 44 Marking for ICE3AR4780JG**

General guideline for PCB layout design using F3 CoolSET™ (Figure 44):

1. “Star Ground “at bulk capacitor ground, C11:

“Star Ground “means all primary DC grounds should be connected to the ground of bulk capacitor C11 separately in one point. It can reduce the switching noise going into the sensitive pins of the CoolSET™ device effectively. The primary DC grounds include the followings.

- a. DC ground of the primary auxiliary winding in power transformer, TR1, and ground of C16 and Z11.
- b. DC ground of the current sense resistor, R12
- c. DC ground of the CoolSET™ device, GND pin of IC11; the signal grounds from C13, C14, C15 and collector of IC12 should be connected to the GND pin of IC11 and then “star “connect to the bulk capacitor ground.
- d. DC ground from bridge rectifier, BR1
- e. DC ground from the bridging Y-capacitor, C4

2. High voltage traces clearance:

High voltage traces should keep enough spacing to the nearby traces. Otherwise, arcing would incur.

- a. 400 V traces (positive rail of bulk capacitor C11) to nearby trace: > 2.0 mm
- b. 600 V traces (drain voltage of CoolSET™ IC11) to nearby trace: > 2.5 mm

3. Filter capacitor close to the controller ground:

Filter capacitors, C13, C14 and C15 should be placed as close to the controller ground and the controller pin as possible so as to reduce the switching noise coupled into the controller.

Guideline for PCB layout design when > 3 kV lightning surge test applied (Figure 44):

1. Add spark gap

Spark gap is a pair of saw-tooth like copper plate facing each other which can discharge the accumulated charge during surge test through the sharp point of the saw-tooth plate.

a. Spark Gap 3 and Spark Gap 4, input common mode choke, L1: Gap separation is around 1.5 mm (no safety concern)

b. Spark Gap 1 and Spark Gap 2, Live / Neutral to GROUND:

These 2 Spark Gaps can be used when the lightning surge requirement is > 6 kV.

230 V<sub>AC</sub> input voltage application, the gap separation is around 5.5mm

115 V<sub>AC</sub> input voltage application, the gap separation is around 3mm

2. Add Y-capacitor (C2 and C3) in the Live and Neutral to ground even though it is a 2-pin input

3. Add negative pulse clamping diode, D11 to the Current sense resistor, R12:

The negative pulse clamping diode can reduce the negative pulse going into the CS pin of the CoolSET™ and reduce the abnormal behavior of the CoolSET™. The diode can be a fast speed diode such as 1N4148.

The principle behind is to drain the high surge voltage from Live/Neutral to Ground without passing through the sensitive components such as the primary controller, IC11.

## Revision History

### Major changes since the last revision

Page or Reference	Description of change
1, 36	change marking

#### Trademarks of Infineon Technologies AG

AURIX™, C166™, CanPAK™, CIPOST™, CoolGaN™, CoolMOS™, CoolSET™, CoolSiC™, CORECONTROL™, CROSSAVE™, DAVE™, DI-POL™, DrBlade™, EasyPIM™, EconoBRIDGE™, EconoDUAL™, EconoPACK™, EconoPIM™, EiceDRIVER™, eupec™, FCOS™, HITFET™, HybridPACK™, Infineon™, ISOFACE™, IsoPACK™, i-Wafer™, MIPAQ™, ModSTACK™, my-d™, NovalithIC™, OmniTune™, OPTIGA™, OptiMOS™, ORIGA™, POWERCODE™, PRIMARION™, PrimePACK™, PrimeSTACK™, PROFET™, PRO-SIL™, RASIC™, REAL3™, ReverSave™, SatRIC™, SIEGET™, SIPMOS™, SmartLEWIS™, SOLID FLASH™, SPOC™, TEMPFET™, thinQ!™, TRENCHSTOP™, TriCore™.

Trademarks updated August 2015

#### Other Trademarks

All referenced product or service names and trademarks are the property of their respective owners.

**Edition 2017-06-13**

**Published by**

**Infineon Technologies AG**

**81726 München, Germany**

**© 2017 Infineon Technologies AG.**

**All Rights Reserved.**

**Do you have a question about this document?**

**Email: [erratum@infineon.com](mailto:erratum@infineon.com)**

**Document reference**

#### IMPORTANT NOTICE

The information given in this document shall in no event be regarded as a guarantee of conditions or characteristics ("Beschaffenheitsgarantie").

With respect to any examples, hints or any typical values stated herein and/or any information regarding the application of the product, Infineon Technologies hereby disclaims any and all warranties and liabilities of any kind, including without limitation warranties of non-infringement of intellectual property rights of any third party.

In addition, any information given in this document is subject to customer's compliance with its obligations stated in this document and any applicable legal requirements, norms and standards concerning customer's products and any use of the product of Infineon Technologies in customer's applications.

The data contained in this document is exclusively intended for technically trained staff. It is the responsibility of customer's technical departments to evaluate the suitability of the product for the intended application and the completeness of the product information given in this document with respect to such application.

For further information on the product, technology, delivery terms and conditions and prices please contact your nearest Infineon Technologies office ([www.infineon.com](http://www.infineon.com)).



#### WARNINGS

Due to technical requirements products may contain dangerous substances. For information on the types in question please contact your nearest Infineon Technologies office.







Except as otherwise explicitly approved by Infineon Technologies in a written document signed by authorized representatives of Infineon Technologies, Infineon Technologies' products may not be used in any applications where a failure of the product or any consequences of the use thereof can reasonably be expected to result in personal injury.

## Looking for pricing, stock, or lifecycle information?

Click below to explore more details on WIN SOURCE:

-  [View ICE3AR4780JGXUMA1 on WIN SOURCE](#)
-  [Infineon Technologies Information](#)

## Optimize Your Supply Chain with WIN SOURCE Solutions

-  Global Sourcing Solution
-  Obsolete Management
-  Cost Control Management
-  Shortage Management
-  Alternative Solution
-  Excess Inventory Management