



THE DATASHEET OF H1201DG



Product Specification for Approval

WE ARE PLEASED IN SUBMITTING OUR SAMPLES WITH SPECIFICATION TO YOU FOR APPROVAL.

CUSTOMER	:	
DESCRIPTION	:	10/100 BASE-T TRANSFORMER
MNC P/N	:	H1201DG
VERSION	:	A0
CUSTOMER P/N	:	
ISSUED DATE	:	2020/04/27
PHOTO OF PRODUCT	:	
WEIGHT	:	1.89g
MADE IN	:	CHINA

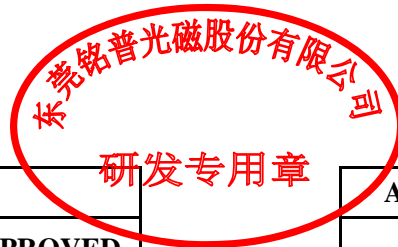

APPROVED BY MNC			APPROVED BY CUSTOMER
PREPARED BY	CHECKED BY	APPROVED BY	SIGNATURE OR STAMP
			

1. PLEASE SEND BACK US A COPY OF THE SPECIFICATION WITH YOUR STAMP OR SIGNATURE ONCE THE SAMPLES APPROVED.
2. IT WILL BE DEEMED THE SAMPLES TO BE APPROVED IF NO FEEDBACK.

东莞铭普光磁股份有限公司
 Add: Shipai Town, Dongguan City, Guangdong Province, China

TEL: +86-769-86921000
 FAX: +86-769-81701563

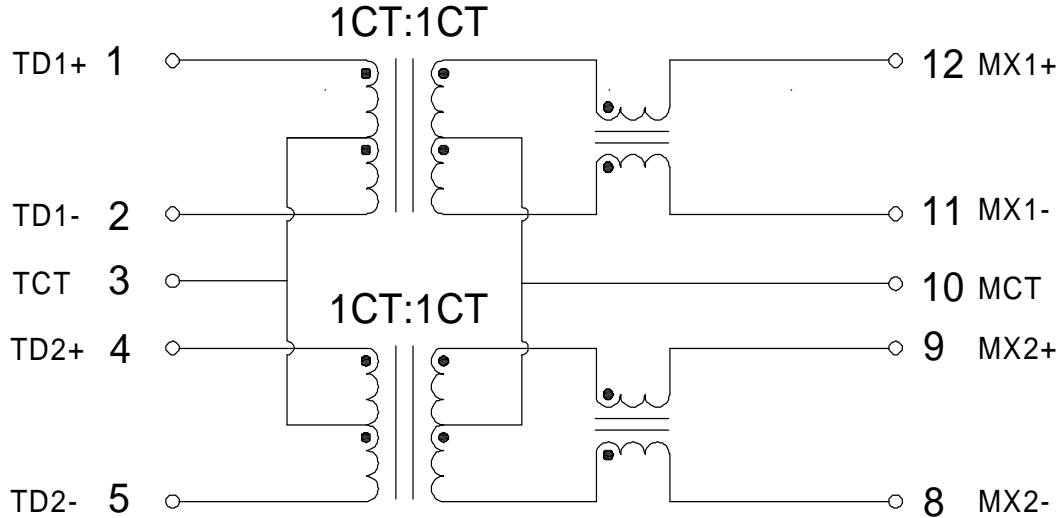
SPECIFICATION
Part No. H1201DG
B. SCHEMATIC :

C. ELECTRICAL SPECIFICATION @25°C

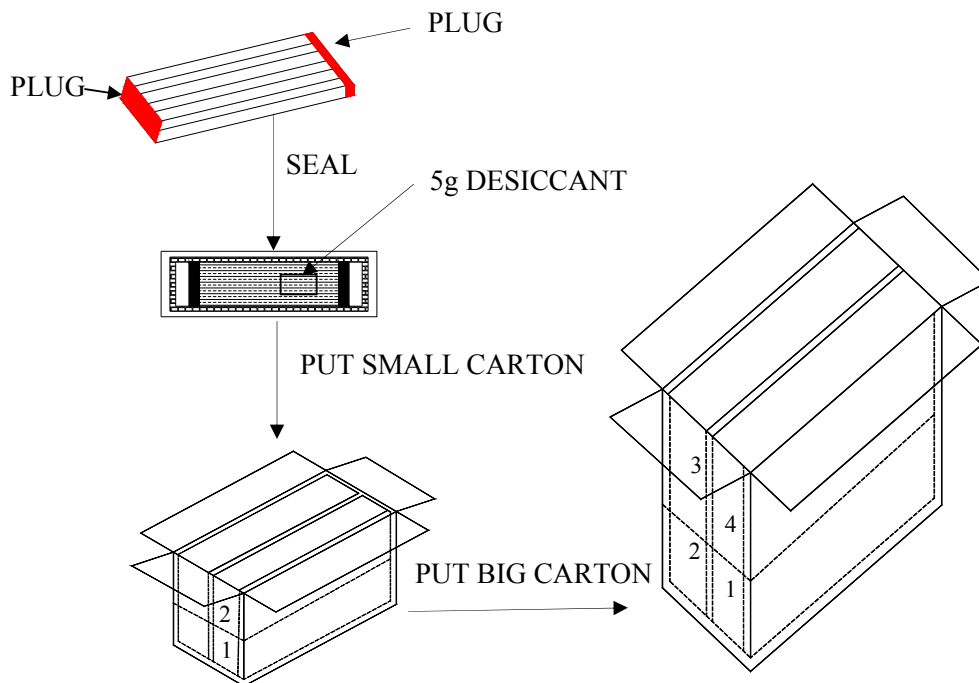
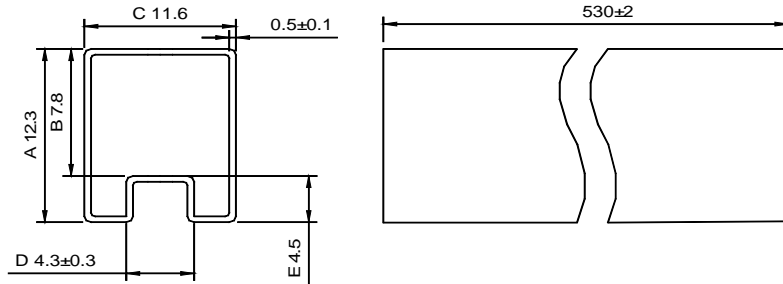
ITEM	SPECIFICATION	TEST CONDITION	TEST EQUIPMENT
INDUCTANCE :	350uH MIN.	100KHz 0.2V 8mA DC Bias	TH2819XB OR EQU.
LEAKAGE INDUCTANCE :	0.50uH MAX.	100KHz 0.2V	TH2819XB OR EQU.
INTERWINDING CAPACITANCE :	50pF TYP.	100KHz 0.2V	TH2819XB OR EQU.
DC RESISTANCE :	1.2Ω MAX.	AT 25 °C	TH2819XB OR EQU.
TURNS RATIO :	1CT:1CT(TX)/ 1CT:1CT(RX)±5%		TH2819XB OR EQU.
POLARITY :	1-12,4-9 IN-PHASE		
INSERTION LOSS :	-1.1dB MAX.	0.5-100 MHz	E5061A OR EQU.
RETURN LOSS :	-18dB MIN.	0.5-30 MHz	E5061A OR EQU.
	-18+20*log(f/30)dB MIN.	30.1-60MHz	
	-12dB MIN.	60.1-80MHz	
CROSS TALK :	-35dB MIN.	0.5-40 MHz	E5061A OR EQU.
CMRR :	-30dB MIN.	0.5-100 MHz	E5061A OR EQU.
ISOLATION HI-POT :PRI TO SEC	1500VAC	1mA,6S	7152AB OR EQU.
	1650VAC	1mA,6S	
OPERATING TEMPERATURE	0°C TO 70°C		

PACKAGE
Part No. H1201DG
D. PACKING:
a. PACKAGING AS BELOW (ONLY FOR A REFERENCE):

b. Q'TY:

- 40 pcs per tube
- 6 tube per bundle (240 pcs)
- 10 bundle per bag (2400 pcs)
- 1 bag per small carton
- 4 small carton per big cartong(9600 pcs)

c. LABEL:

REMARK:

ABOVE PACKING IS FOR YOUR REFERENCE ONLY, WHICH MIGHT BE CHANGED WITHOUT NOTICE.

MATERIAL LIST
Part No. H1201DG
E.BOM

MATERIAL LIST					
NO.	ITEM	MATERIAL	RATING	SUPPLIER OF MATERIAL	UL
1	CORE	Mn-Zn	-----	YEAN SHING	N/A
			-----	ZHONGSHAN CRC ELECTRONICS FACTORY	N/A
		Ni-Zn	-----	YEAN SHING	N/A
			-----	ZHONGSHAN CRC ELECTRONICS FACTORY	N/A
2	COPPER WIRE	QPN180	180℃	ZHUHAI SUNTEK WIRE CO.,LTD	E234867
		Polysol 180	180℃	ELEKTRISOLA(MALAYSIA) SDN.BHD.	E258243
3	BASE	PF2A5-151J(b)	V-0	CHANGSHU SOUTH-EAST PLASTIC CO.,LTD	E136137
		T378J	V-0	CHANG CHUN CHEMICAL(ZHANGZHOU) CO.,LTD.	E59481
4	PIN	CP WIRE	-----	HIFAM	N/A
5	EPOXY	3300A/B	V-0	DONGGUAN EATTO ELECTRONIC MATERIAL CO.,LTD	E218090

RECOMMENDED SOLDERING PROFILE

Part No. H1201DG

a. RECOMMENDED WAVE SOLDERING PROFILE:

CONDITION:

- a.1. AVAILABLE FOR ALL THE THROUGH HOLE PARTS
- a.2. SOLDERING METHOD: WAVE SOLDERING
- a.3. SOLDER: Sn-0.7Cu
- a.4. THE RECOMMENDED WAVE SOLDERING CURVE IS AS BELOW

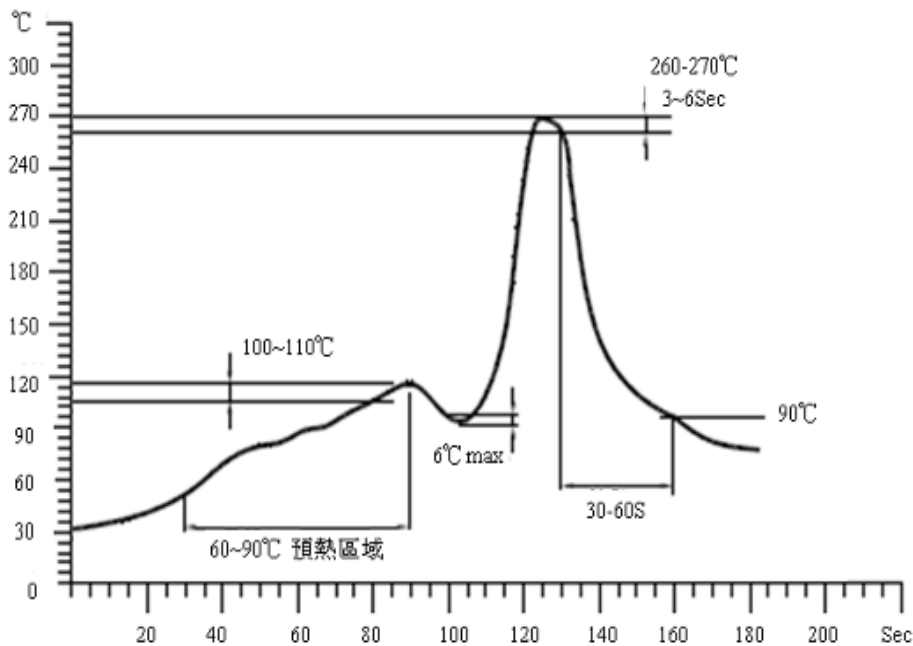



b. MOISTURE SENSITIVE LEVEL:

- b.1. LEVEL: 1
- b.2. SHELF LIFE: UNLIMITED
- b.3. STORAGE CONDITION: $\leq 30^{\circ}\text{C}/85\% \text{RH}$

Looking for pricing, stock, or lifecycle information?

Click below to explore more details on WIN SOURCE:

-  [View H1201DG on WIN SOURCE](#)
-  [Mentech Technology USA Inc. Information](#)

Optimize Your Supply Chain with WIN SOURCE Solutions

-  Global Sourcing Solution
-  Obsolete Management
-  Cost Control Management
-  Shortage Management
-  Alternative Solution
-  Excess Inventory Management