



**THE DATASHEET OF
GS1528-CTAE3**





GS1528 HD-LINX II Multi-Rate SDI Dual Slew-Rate Cable Driver

Features

- SMPTE 292M, SMPTE 344M and SMPTE 259M compliant
- dual coaxial cable driving outputs with selectable slew rate
- 50Ω differential PECL input
- seamless interface to other HD-LINX® II family products
- Pb-free and RoHS Compliant
- single 3.3V power supply operation
- operating temperature range: 0°C to 70°C

Applications

- SMPTE 292M, SMPTE 344M and SMPTE 259M Coaxial Cable Serial Digital Interfaces.

Description

The GS1528 is a second generation high-speed bipolar integrated circuit designed to drive one or two 75Ω co-axial cables at data rates up to 1.485Gb/s. The GS1528 provides two selectable slew rates in order to achieve compliance to SMPTE 259M, SMPTE 344M and SMPTE 292M.

The GS1528 accepts a LVPECL level differential input that may be AC-coupled. External biasing resistors at the inputs are not required.

Power consumption is typically 160mW using a 3.3V power supply.

This component and all homogeneous subcomponents are RoHS compliant.

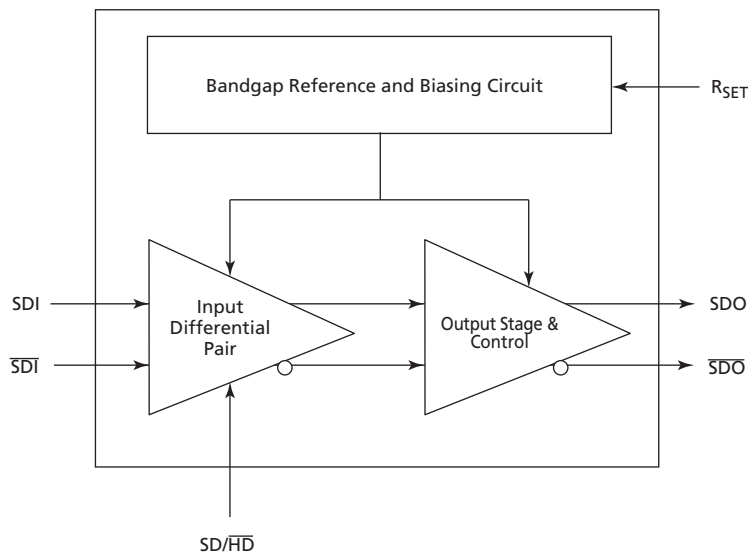

Functional Block Diagram

Revision History

Version	ECR	PCN	Date	Changes and / or Modifications
9	154748	-	August 2010	Corrected Figure 5-1: Package Dimensions .
8	152046	-	June 2009	Removed 'Proprietary & Confidential' from footer.
7	151340	-	February 2009	Updated document format. Added 2,500pc reel, and removed leaded parts in section 5.1 Ordering Information .
6	139116	38124	January 2006	Corrected Serial Input Swing to 2200mV
5	137163	-	June 2005	Rephrased RoHS compliance statement.
4	136566	-	April 2005	Updated 'Green' references to RoHS Compliant.

Contents

1.1 Absolute Maximum Ratings	3
1.2 DC Electrical Characteristics	3
1.3 AC Electrical Characteristics	4
2.1 Pin Assignment	5
2.2 Pin Descriptions	5
2.3 Input/Output Circuits	6
3.1 Input Interfacing	7
3.2 SD/HD	7
3.3 Output Interfacing	7
3.4 Output Return Loss Measurement	9
3.5 Output Amplitude Adjustment	10
4.1 PCB Layout	11
4.2 Typical Application Circuit	11
5.1 Ordering Information	12

1. Electrical Characteristics

1.1 Absolute Maximum Ratings

$T_A = 25^\circ\text{C}$ unless otherwise indicated

Parameter	Value
Supply Voltage	-0.5V to 3.6 V_{DC}
Input ESD Voltage	500V
Storage Temperature Range	$-50^\circ\text{C} < T_s < 125^\circ\text{C}$
Input Voltage Range (any input)	-0.3 to $(V_{CC} + 0.3)V$
Operating Temperature Range	0°C to 70°C
Power Dissipation	300mW
Lead Temperature (soldering, 10 sec)	260°C

CAUTION The GS1528 is sensitive to electrostatic discharge. Use extreme caution, observing all ESD-prevention practices, during handling and assembly. The SDI inputs of the GS1528 must be protected from electrostatic discharge and electrical overstress during the handling and operation of circuit assemblies

1.2 DC Electrical Characteristics

Table 1-1: DC Electrical Characteristics

$V_{DD} = 3.3V$, $T_A = 0^\circ\text{C}$ to 70°C , unless otherwise shown

Parameter	Conditions	Symbol	Min	Typ	Max	Units	Notes	Test Levels
Supply Voltage		V_{CC}	3.135	3.3	3.465	V	$\pm 5\%$	3
Power Consumption	$T_A = 25^\circ\text{C}$	P_D	–	160	–	mW		5
Supply Current	$T_A = 25^\circ\text{C}$	I_s	–	48	–	mA		1
Output Voltage	Common mode	V_{CMOUT}	–	$V_{CC} - V_{OUT}$	–	–		6
Input Voltage	Common mode	V_{CMIN}	$1.6 + \Delta V_{SDI}/2$	–	$V_{CC} - \Delta V_{SDI}/2$	V		5
SD/ $\overline{\text{HD}}$ Input		V_{IH}	2.4	–	–	V		7
		V_{IL}	–	–	0.8	V		7

1.3 AC Electrical Characteristics

Table 1-2: AC Electrical Characteristics

$V_{DD} = 3.3V$, $T_A = 0^{\circ}C$ to $70^{\circ}C$, unless otherwise shown

Parameter	Conditions	Symbol	Min	Typ	Max	Units	Notes	Test Levels
Serial input data rate		DR_{SDO}	–	–	1.485	Gb/s	2	1
Additive jitter	1.485Gb/s		–	15	–	ps_{p-p}		1
	270Mb/s		–	25	–	ps_{p-p}		1
Rise/Fall time	$SD/\overline{HD}=0$	t_r, t_f	–	–	220	ps	20% to 80%	1
	$SD/\overline{HD}=1$	t_r, t_f	400	–	800	ps	20% to 80%	1
Mismatch in rise/fall time		$\Delta t_r, \Delta t_f$	–	–	30	ps		1
Duty cycle distortion			–	–	30	ps		1
Overshoot			–	–	8	%		1
Output Return Loss		ORL	15	–	–	dB	1	7
Output Voltage Swing	Single Ended into 75Ω external load $R_{SET} = 750\Omega$	V_{OUT}	750	800	850	mV_{p-p}		1
Input Voltage Swing	Differential	ΔV_{SDI}	300	–	2200	mV_{p-p}		1

TEST LEVELS

1. Production test at room temperature and nominal supply voltage with guardbands for supply and temperature ranges.
2. Production test at room temperature and nominal supply voltage with guardbands for supply and temperature ranges using correlated test.
3. Production test at room temperature and nominal supply voltage.
4. QA sample test.
5. Calculated result based on Level 1, 2, or 3.
6. Not tested. Guaranteed by design simulations.
7. Not tested. Based on characterization of nominal parts.
8. Not tested. Based on existing design/characterization data of similar product.
9. Indirect test.

NOTES:

1. Tested on CB1528 board from 5MHz to 1.435GHz
2. The input coupling capacitor must be set accordingly for lower data rates.

2. Pin Out

2.1 Pin Assignment

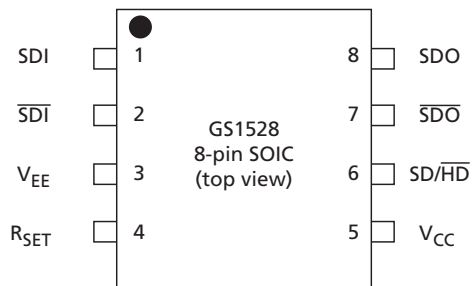

Figure 2-1: 8-Pin SOIC

2.2 Pin Descriptions

Table 2-1: Pin Descriptions

Pin Number	Name	Type	Description
1,2	SDI, $\overline{\text{SDI}}$	PECL INPUT	Serial digital differential input.
3	V_{EE}	POWER	Most negative power supply connection. Connect to GND.
4	R_{SET}	INPUT	External output amplitude control resistor.
5	V_{CC}	POWER	Most positive power supply connection. Connect to +3.3V.
6	SD/HD	LOGIC INPUT	Output slew rate control. When HIGH, the output will meet SMPTE259M rise/fall time specifications. When LOW, the serial outputs will meet SMPTE292M rise/fall time specifications.
7, 8	$\overline{\text{SDO}}$, SDO	OUTPUT	Serial digital differential output.

2.3 Input/Output Circuits

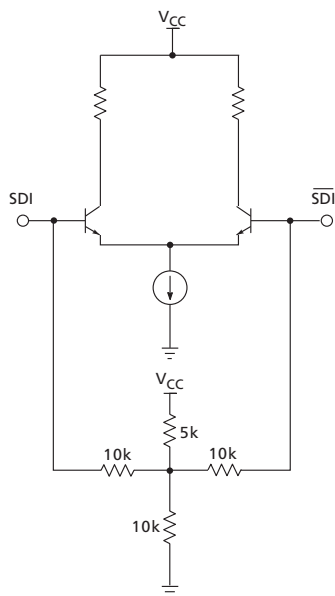

Figure 2-2: Differential Input Stage (SDI/ $\overline{\text{SDI}}$)

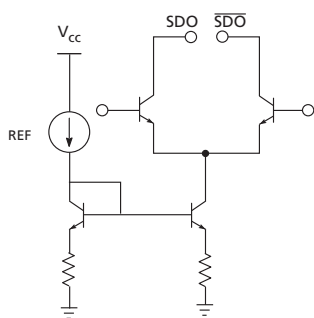

Figure 2-3: Differential Output Stage (SDO/ $\overline{\text{SDO}}$)
 I_{REF} derived using R_{SET}

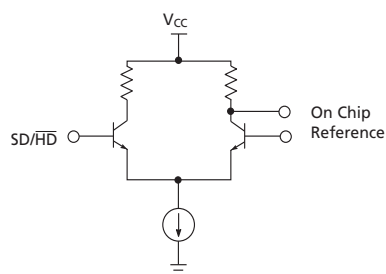

Figure 2-4: Slew Rate Select Input Stage (SD/ $\overline{\text{H-D}}$)

3. Detailed Description

3.1 Input Interfacing

SDI/ $\overline{\text{SDI}}$ are high-impedance differential inputs (see [Figure 2-1](#) for equivalent input circuit).

Several conditions must be observed when interfacing to these inputs:

1. The differential input signal amplitude must be between 300 and 2000mVpp.
2. The common mode voltage range must be as specified in [Table 1-1: DC Electrical Characteristics](#).
3. For input trace lengths longer than approximately 1cm, the inputs should be terminated as shown in the [Typical Application Circuit](#).

The GS1528 inputs are self-biased, allowing for simple AC-coupling to the device. For serial digital video, a minimum capacitor value of 4.7 μ F should be used to allow coupling of pathological test signals. A tantalum capacitor is recommended.

3.2 SD/ $\overline{\text{HD}}$

The GS1528 SDO rise and fall times can be set to comply with both SMPTE 259M/344M and SMPTE 292M. For all SMPTE 259M standards, or any data rate that requires longer rise and fall time characteristics, the SD/ $\overline{\text{HD}}$ pin must be set to a HIGH INPUT. For SMPTE 292M standards and signals which require faster rise and fall times, this pin should be set to a LOW INPUT.

3.3 Output Interfacing

The GS1528 outputs are current mode, and will drive 800mV into a 75 Ω load. These outputs are protected from accidental static damage with internal static protection diodes.

The SMPTE 292M, SMPTE 344M and SMPTE 259M standards requires that the output of a cable driver have a source impedance of 75 Ω and a return loss of at least 15dB between 5MHz and 1.485GHz.

In order for an SDI output circuit using the GS1528 to meet this specification, the output circuit shown in the [Typical Application Circuit](#) is recommended.

The value of L_{COMP} will vary depending on the PCB layout, with a typical value of 5.6nH (see the [Application Information on page 11](#) in this data sheet for further details). A 4.7 μ F capacitor is used for AC-coupling the output of the GS1528. This value is chosen to ensure that pathological signals can be coupled without a significant DC component occurring.

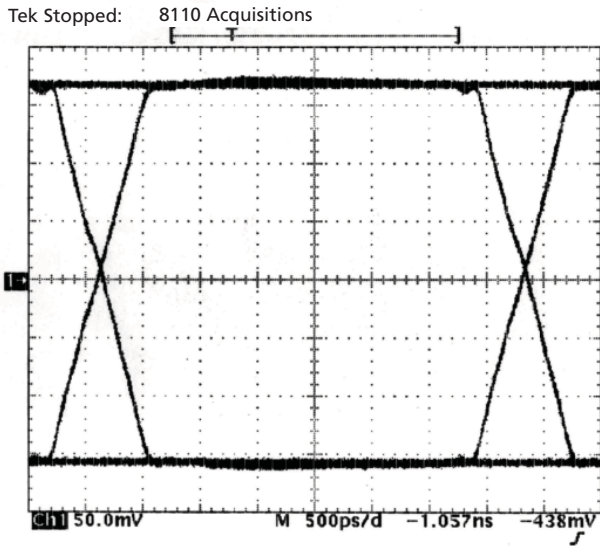

Figure 3-1: Output signal for 270Mb/s input

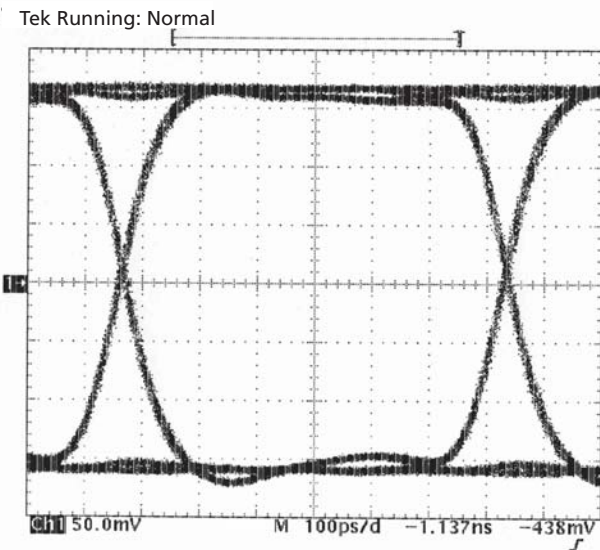

Figure 3-2: Output signal for 1.485Gb/s input

When measuring return loss at the GS1528 output, it is necessary to take the measurement for both a logic high and a logic low output condition. This is because the output protection diodes act as varactors (voltage controlled capacitors) as shown in [Figure 3-3](#).

Consequently, the output capacitance of the GS1528 is dependent on the logic state of the output.

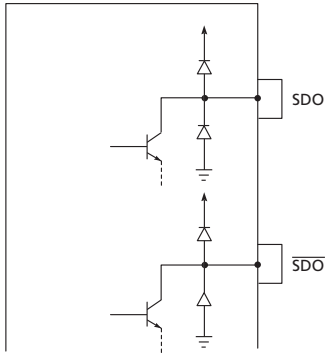

Figure 3-3: Static Protection Diodes

3.4 Output Return Loss Measurement

To perform a practical return loss measurement, it is necessary to force the GS1528 output to a DC high or low condition. The actual measured return loss will be based on the outputs being static at V_{CC} or $V_{CC}-1.6V$. Under normal operating conditions the outputs of the GS1528 swing between $V_{CC}-0.4V$ and $V_{CC}-1.2V$, so the measured value of return loss will not represent the actual operating return loss.

A simple method of calculating the values of actual operating return loss is to interpolate the two return loss measurements. In this way, the values of return loss are estimated at $V_{CC}-0.4V$ and $V_{CC}-1.2V$ based on the measurements at V_{CC} and $V_{CC}-1.6V$.

The two values of return loss (high and low) will typically differ by several decibels. If the measured return loss is R_H for logic high and R_L for logic low, then the two values can be interpolated as follows:

$$R_{IH} = R_H - (R_H - R_L)/4 \text{ and}$$

$$R_{IL} = R_L + (R_H - R_L)/4$$

Where R_{IH} is the interpolated logic high value and R_{IL} is the interpolated logic low value.

For example: if $R_H = -18dB$ and $R_L = -14dB$, then the interpolated values are $R_{IH} = -17dB$ and $R_{IL} = -15dB$.

3.5 Output Amplitude Adjustment

The output amplitude of the GS1528 can be adjusted by changing the value of the R_{SET} resistor as shown in Figure 3-4 and Table 3-1. For an 800mV_{p-p} output with a nominal $\pm 7\%$ tolerance, a value of 750Ω is required. A $\pm 1\%$ SMT resistor should be used.

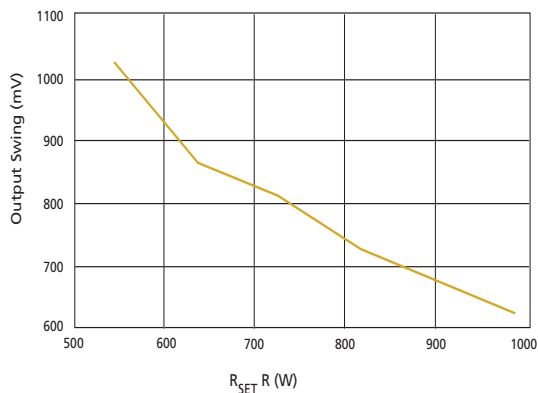

Figure 3-4: Output Amplitude Adjustment

The R_{SET} resistor is part of the high-speed output circuit of the GS1528. The resistor should be placed as close as possible to the R_{SET} pin. In addition, the PCB capacitance should be minimized at this node by removing the PCB ground plane beneath the R_{SET} resistor and the R_{SET} pin.

Table 3-1: R_{SET} vs. V_{OD}

R_{SET} Resistance (Ω)	Output Swing
995	608
824	734
750	800
600	884
573	1040

NOTE: For reliable operation of the GS1528 over the full temperature range, do not use an R_{SET} value below 573Ω .

4. Application Information

4.1 PCB Layout

Special attention must be paid to component layout when designing serial digital interfaces for HDTV. An FR-4 dielectric can be used, however, controlled impedance transmission lines are required for PCB traces longer than approximately 1cm. Note the following PCB artwork features used to optimize performance:

- The PCB trace width for HD rate signals is closely matched to SMT component width to minimize reflections due to changes in trace impedance
- The PCB groundplane is removed under the GS1528 output components to minimize parasitic capacitance
- The PCB ground plane is removed under the GS1528 R_{SET} pin and resistor to minimize parasitic capacitance
- Input and output BNC connectors are surface-mounted in-line to eliminate transmission line stubs caused by a BNC mounting via high-speed traces, which are curved to minimize impedance variations due to change of PCB trace width

4.2 Typical Application Circuit

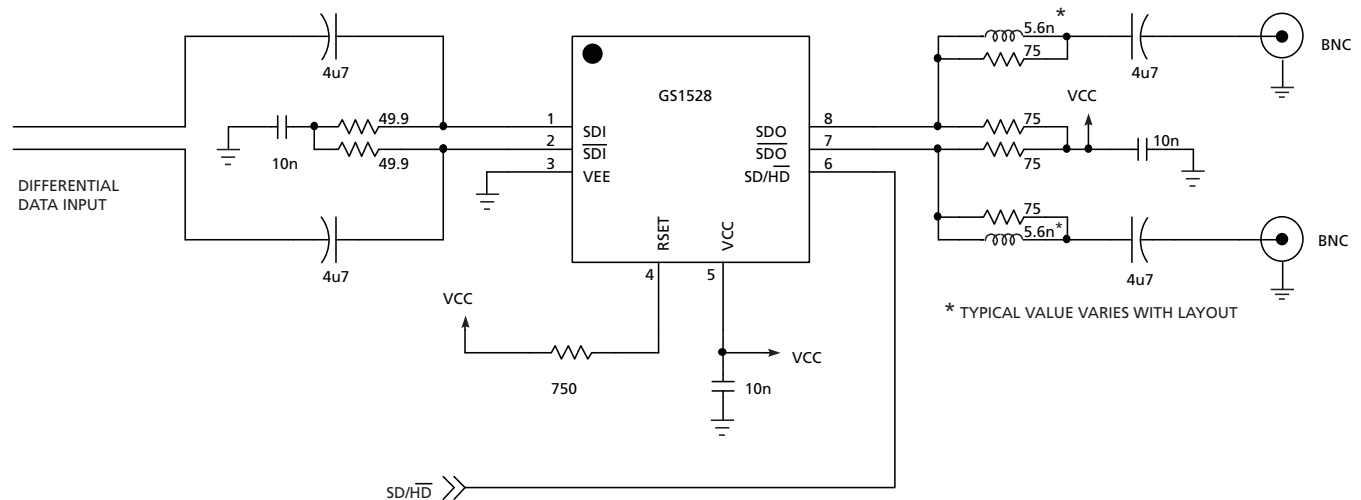

NOTE: All resistors in Ohms, capacitors in Farads, and inductors in Henrys, unless otherwise noted.

Figure 4-1: GS1528 Typical Application Circuit

5. Package Dimensions

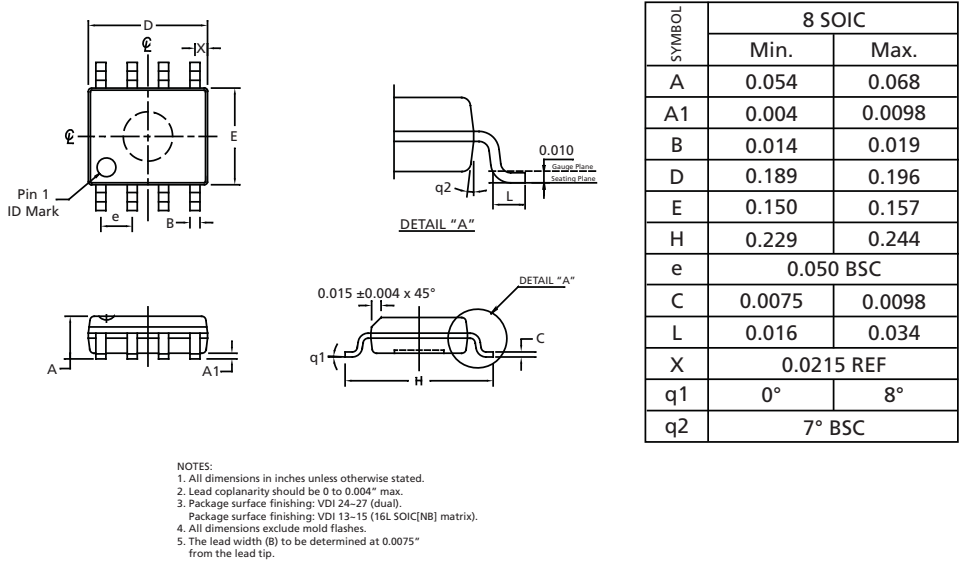

Figure 5-1: Package Dimensions

5.1 Ordering Information

Part Number	Package	Temperature	Pb-Free and RoHS Compliant
GS1528-CKAE3	8 pin SOIC	0°C to 70°C	Yes
GS1528-CTAE3	8 pin SOIC, tape & reel (250pc)	0°C to 70°C	Yes
GS1528-CTAE3Z	8 pin SOIC, tape & reel (2,500pc)	0°C to 70°C	Yes

**DOCUMENT IDENTIFICATION
DATA SHEET**

The product is in production. Genum reserves the right to make changes to the product at any time without notice to improve reliability, function or design, in order to provide the best product possible.

CAUTION

ELECTROSTATIC SENSITIVE DEVICES
DO NOT OPEN PACKAGES OR HANDLE EXCEPT AT A
STATIC-FREE WORKSTATION



GENNUM CORPORATE HEADQUARTERS

4281 Harvester Road, Burlington, Ontario L7L 5M4 Canada

Phone: +1 (905) 632-2996

E-mail: corporate@gennum.com

Fax: +1 (905) 632-2055

www.gennum.com

OTTAWA

232 Herzberg Road, Suite 101
Kanata, Ontario K2K 2A1
Canada

Phone: +1 (613) 270-0458

Fax: +1 (613) 270-0429

CALGARY

3553 - 31st St. N.W., Suite 210
Calgary, Alberta T2L 2K7
Canada

Phone: +1 (403) 284-2672

UNITED KINGDOM

North Building, Walden Court
Parsonage Lane,
Bishop's Stortford Hertfordshire, CM23 5DB
United Kingdom

Phone: +44 1279 714170

Fax: +44 1279 714171

INDIA

#208(A), Nirmala Plaza,
Airport Road, Forest Park Square
Bhubaneswar 751009
India

Phone: +91 (674) 653-4815

Fax: +91 (674) 259-5733

SNOWBUSH IP - A DIVISION OF GENNUM

439 University Ave. Suite 1700
Toronto, Ontario M5G 1Y8
Canada

Phone: +1 (416) 925-5643

Fax: +1 (416) 925-0581

E-mail: sales@snowbush.com

Web Site: <http://www.snowbush.com>

MEXICO

288-A Paseo de Maravillas
Jesus Ma., Aguascalientes
Mexico 20900

Phone: +1 (416) 848-0328

JAPAN KK

Shinjuku Green Tower Building 27F
6-14-1, Nishi Shinjuku
Shinjuku-ku, Tokyo, 160-0023
Japan

Phone: +81 (03) 3349-5501

Fax: +81 (03) 3349-5505

E-mail: gennum-japan@gennum.com

Web Site: <http://www.gennum.co.jp>

TAIWAN

6F-4, No.51, Sec.2, Keelung Rd.
Sinyi District, Taipei City 11502
Taiwan R.O.C.

Phone: (886) 2-8732-8879

Fax: (886) 2-8732-8870

E-mail: gennum-taiwan@gennum.com

GERMANY

Hainbuchenstraße 2
80935 Muenchen (Munich), Germany

Phone: +49-89-35831696

Fax: +49-89-35804653

E-mail: gennum-germany@gennum.com

NORTH AMERICA WESTERN REGION

691 South Milpitas Blvd., Suite #200
Milpitas, CA 95035
United States

Phone: +1 (408) 934-1301

Fax: +1 (408) 934-1029

E-mail: naw_sales@gennum.com

NORTH AMERICA EASTERN REGION

4281 Harvester Road
Burlington, Ontario L7L 5M4
Canada

Phone: +1 (905) 632-2996

Fax: +1 (905) 632-2055

E-mail: nae_sales@gennum.com

KOREA

8F Jinnex Lakeview Bldg.
65-2, Bangidong, Songpagu
Seoul, Korea 138-828

Phone: +82-2-414-2991

Fax: +82-2-414-2998

E-mail: gennum-korea@gennum.com

Genum Corporation assumes no liability for any errors or omissions in this document, or for the use of the circuits or devices described herein. The sale of the circuit or device described herein does not imply any patent license, and Genum makes no representation that the circuit or device is free from patent infringement.

All other trademarks mentioned are the properties of their respective owners.

GENNUM and the Genum logo are registered trademarks of Genum Corporation.

© Copyright 2002 Genum Corporation. All rights reserved.

www.gennum.com

Looking for pricing, stock, or lifecycle information?

Click below to explore more details on WIN SOURCE:

- ⊖ [View GS1528-CTAE3](#) on WIN SOURCE
- ⊖ [Semtech Corporation](#) Information

Optimize Your Supply Chain with WIN SOURCE Solutions

- ✓ Global Sourcing Solution
- ✓ Obsolete Management
- ✓ Cost Control Management
- ✓ Shortage Management
- ✓ Alternative Solution
- ✓ Excess Inventory Management