

Motor Drivers for Digital Still Cameras

5-Channel System Lens Driver for Digital Still Cameras

BD6370GUL
General Description

The BD6370GUL is a motor driver that integrates 3 Full-ON or Constant-Voltage type H-bridges, 1 Constant-Voltage or Linear Constant-Current or Full-ON type H-bridge and 1 Linear Constant-Current type H-bridge. The device can drive one stepping motor for auto focus, and DC motors for zoom and iris. It is therefore possible to drive another stepping motor for either zoom or iris, because it has the system to drive 6-channel H-bridges exclusively.

Features

- Low ON-Resistance Power CMOS Output
- Drive Mode Switch Function
- Serial Interface 3-line Bus Control
- Exclusive 6-Channel Drive Function
- 6-Bits D/A Converters for Constant-Voltage and Constant-Current Control
- High-Precision ($\pm 5\%$) Constant-Voltage Driver
- High-Precision ($\pm 3\%$) Linear Constant-Current Driver
- Both Constant-Voltage Drive Block and Constant-Current Drive Block feature Phase Compensation Capacitor-Free Design
- Under Voltage Locked Out Protection & Thermal Shut Down Circuit

Applications

- Mobile system
- Home appliance
- Amusement system, etc

Key Specifications

- Power Supply Voltage Range: 2.7V to 5.5V
- Motor Power Supply Voltage Range: 2.7V to 5.5V
- Circuit Current: 1.3mA(Typ)
- Stand-By Current: 3.0 μ A(Max)
- Control Input Voltage Range: 0V to V_{CC} V
- H-Bridge Output Current: -0.4A/ch to +0.4A/ch
- Output ON-Resistance(Each Channel): 1.4 Ω (Typ)
- Operating Temperature Range: -25°C to +85°C

Package

VCSP50L2

W(Typ) x D(Typ) x H(Max)

2.60mm x 2.60mm x 0.55mm

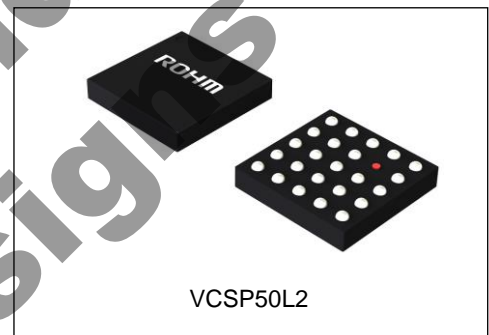

Typical Application Circuit

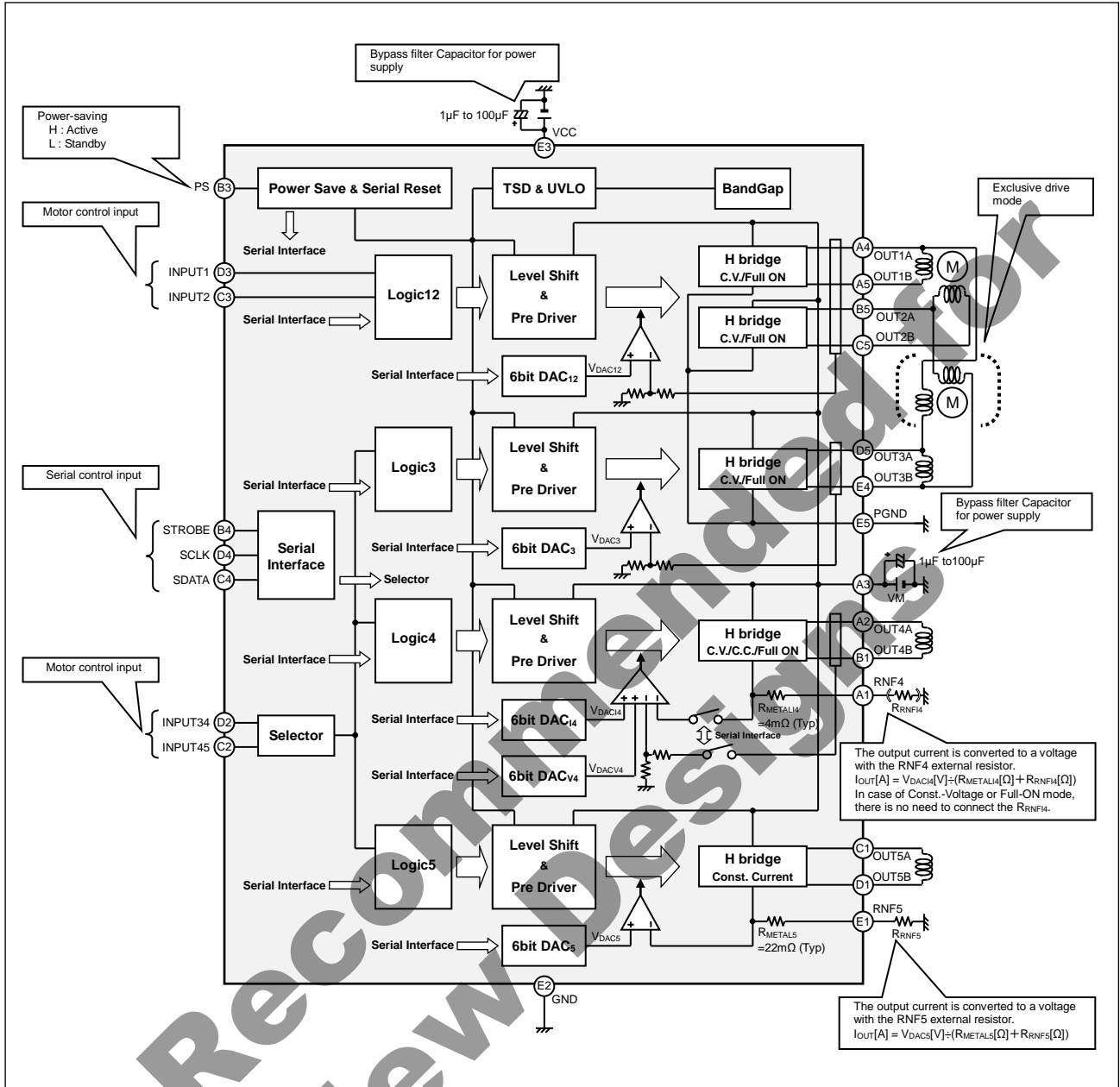

Not Recommended for New Designs

Pin Configurations

(TOP VIEW)

	1	2	3	4	5
A	RNF4	OUT4A	VM	OUT1A	OUT1B
B	OUT4B	INDEX POST	PS	STROBE	OUT2A
C	OUT5A	INPUT45	INPUT2	SDATA	OUT2B
D	OUT5B	INPUT34	INPUT1	SCLK	OUT3A
E	RNF5	GND	VCC	OUT3B	PGND

Pin Descriptions

Pin No.	Pin Name	Function	Pin No.	Pin Name	Function
A1	RNF4	Current detect resistor ch.4	D1	OUT5B	H-bridge output 5B
A2	OUT4A	H-bridge output 4A	D2	INPUT34	Control logic input 34
A3	VM	Motor power supply	D3	INPUT1	Control logic input 1
A4	OUT1A	H-bridge output 1A	D4	SCLK	Serial clock input
A5	OUT1B	H-bridge output 1B	D5	OUT3A	H-bridge output 3A
B1	OUT4B	H-bridge output 4B	E1	RNF5	Current detect resistor ch.5
B2	INDEX POST		E2	GND	Ground
B3	PS	Power-saving	E3	VCC	Power supply
B4	STROBE	Serial enable input	E4	OUT3B	H-bridge output 3B
B5	OUT2A	H-bridge output 2A	E5	PGND	Motor ground ch.1 to ch.3
C1	OUT5A	H-bridge output 5A			
C2	INPUT45	Control logic input 45			
C3	INPUT2	Control logic input 2			
C4	SDATA	Serial data input			
C5	OUT2B	H-bridge output 2B			

Block Diagram

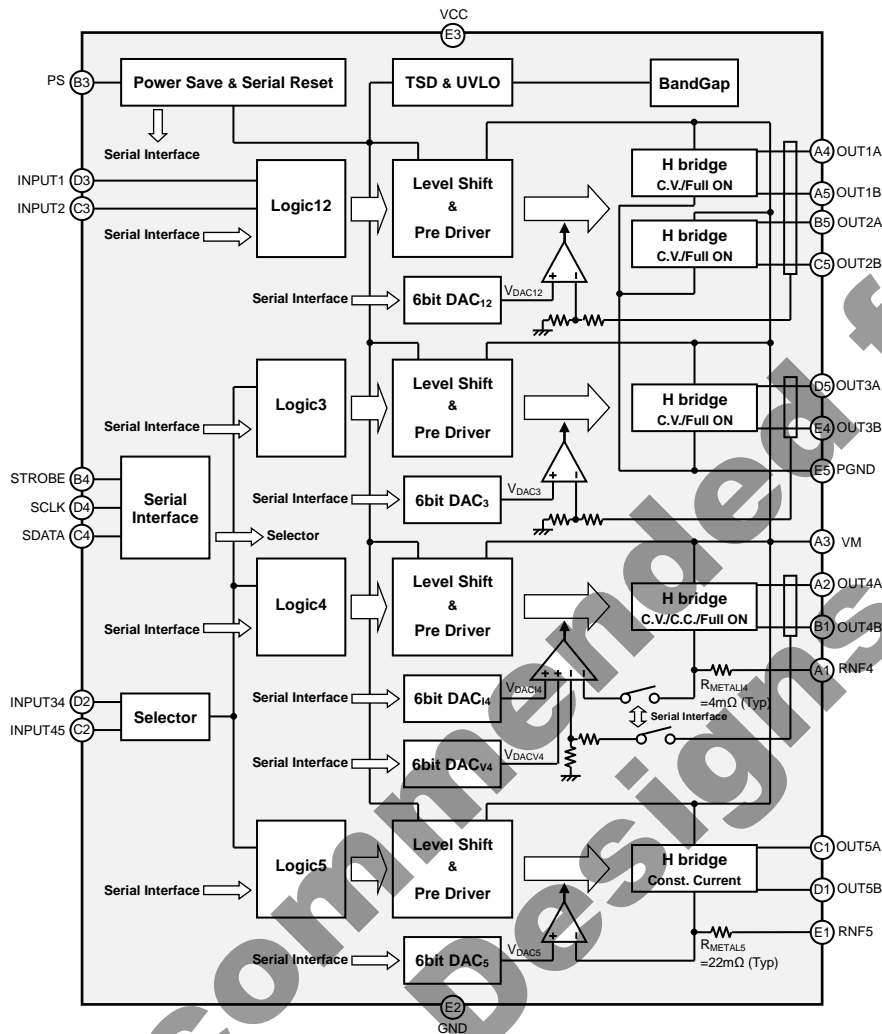

Description of Blocks

1. Power-Saving and Serial Reset

A power-saving function is included, which allows the system to save power when not driving the motor. The voltage level on this pin should be set high so as to keep the operation mode. (See the Electrical Characteristics; p.7/32)
Cancel power-saving mode after turning on power supply V_{CC} and V_M , because PS pin combines with power-saving function and serial reset function block. If PS pin is always short-circuited to the power supply V_{CC} terminal, reset function may not work, and it may cause the device to malfunction.
(See the Sequence of Serial Control Input; p.9/32)

2. Motor Control Input (INPUT1, INPUT2, INPUT34, INPUT45)

Logic level controls the output logic of H-Bridge.
(See the Electrical Characteristics; p.7/32 and I/O Truth Table; p.19/32 to p.23/32)
INPUT34 pin corresponds to channel 3 or channel 4, and INPUT45 pin to channel 4 or channel 5 respectively. These channels can be set via serial interface.

3. H-Bridge

Because the respective output transistors consist of power CMOS which consumes a motor power supply V_M , the high and low-side ON-Resistance value is dependent upon V_M voltage. Further, the application must be designed so that the maximum H-bridge current for each channel is 400mA or below.
(See the Recommended Operating Conditions; p.6/32)
The 3 H-bridges (channel 1 to channel 3) can be driven as the exclusive 4-channel. As long as two stepping motors don't drive simultaneously, it is possible to drive them by channel 1 to channel 3.

Description of Blocks – continued

4. The D/A Converter Settings for Each Channel

The three H-Bridges (channel 1 to 3) can drive motors as Constant-Voltage or Full-ON mode. The H-Bridge of channel 4 can drive it as Constant-Voltage or Constant-Current or Full-ON mode, while the H-Bridge of channel 5 is always set for Constant-Current mode. In case of driving each H-bridge as Full-ON mode, serial data of each D/A Converter (DAC12 and DAC3) for Constant-Voltage mode should be set all bits high. If channel 4 is set to Constant-Voltage mode, serial data of D/A Converter (DAC14) for Constant-Current mode should be set all bits high. In case of driving H-bridge as Constant-Current mode, serial data of D/A Converter (DACV4) for Constant-Voltage mode should be set all bits high, while driving as Full-ON mode, serial data of both D/A Converters should be set all bits high. In case of driving channel 4 as Constant-Voltage or Full-ON mode, it is not necessary to connect the external resistor for output current detection at RNF4 pin. When driving as Constant-Current mode, design the application in consideration of both internal metal impedance and external resistor for output current detection.

(a) Full-ON Mode (Channel 1 to Channel 4)

D/A Converter Setting Range

V_{DACx} : 6'b111111 Fixed ($x = 12, 3, V4$, and I4)

(b) Constant-Voltage Mode (Channel 1 to Channel 4)

Formula for Output High Voltage:

$V_{VOHx}[V] = 8 \times V_{DACx}[V]$ ($8 \times V_{DACx} \leq V_M[V]$, $x = 12, 3$, and V4)

$V_{VOHx}[V] = V_M[V]$ ($8 \times V_{DACx} > V_M[V]$, $x = 12, 3$, and V4)

D/A Converter Setting Range

$8 \times V_{DACx}$: 6'b010100 to 111111 ($x = 12, 3$, and V4)

(In case of setting channel 4, set V_{DAC14} : 6'b111111, in addition to the above condition)

(c) Constant-Current Mode (Channel 4 & Channel 5)

Formula for Output Current:

$I_{OUTx}[A] = V_{DACx}[V] / (R_{METALx}[\Omega] + R_{NFx}[\Omega])$ ($x = I4$ and 5)

R_{METALx} : the internal metal impedance

(Channel 4; $R_{METAL4}[\Omega] = 0.004$ (Typ))

(Channel 5; $R_{METAL5}[\Omega] = 0.022$ (Typ))

R_{NFx} : the resistor value for output current detection at RNFx pin

D/A Converter Setting Range

V_{DACx} : 6'b001010 to 111111 ($x = I4$ and 5)

(In case of setting channel 4, set V_{DACV4} : 6'b111111, in addition to the above condition)

Absolute Maximum Ratings (Ta=25°C)

Parameter	Symbol	Limit	Unit
Power Supply Voltage	V _{CC}	-0.3 to +6.5	V
Motor Power Supply Voltage	V _M	-0.3 to +6.5	V
Control Input Voltage	V _{IN}	-0.3 to +V _{CC} +0.3	V
Power Dissipation	P _d	0.83 ^(Note 1)	W
H-bridge Output Current	I _{OUT}	-0.5 to +0.5 ^(Note 2)	A/ch
Storage Temperature Range	T _{stg}	-55 to +150	°C
Junction Temperature	T _{jmax}	150	°C

(Note 1) Reduced by 6.64mW/°C over 25°C, when mounted on a glass epoxy board (50mm x 58mm x 1.75mm; 8layers)

(Note 2) Must not exceed P_d, A_{SO}, or T_{jmax} of 150°C

Caution: Operating the IC over the absolute maximum ratings may damage the IC. The damage can either be a short circuit between pins or an open circuit between pins and the internal circuitry. Therefore, it is important to consider circuit protection measures, such as adding a fuse, in case the IC is operated over the absolute maximum ratings.

Recommended Operating Conditions

Parameter	Symbol	Min	Typ	Max	Unit
Power Supply Voltage	V _{CC}	2.7	-	5.5	V
Motor Power Supply Voltage	V _M	2.7	-	5.5	V
Control Input Voltage	V _{IN}	0	-	V _{CC}	V
Control Input Frequency ^(Note 3)	f _{IN}	0	-	100	kHz
Serial Clock Input Frequency ^(Note 3)	f _{SCLK}	0	-	10	MHz
H-bridge Output Current ^(Note 4)	I _{OUT}	-0.4	-	+0.4	A/ch
Operating Temperature Range	T _{opr}	-25	-	+85	°C

(Note 3) ON duty=50%

(Note 4) Must not exceed P_d, A_{SO}, or T_{jmax} of 150°C

Electrical Characteristics (Unless otherwise specified $V_{CC}=3.0V$, $V_M=5.0V$, $T_a=25^\circ C$, Serial=Binary Notation)

Parameter	Symbol	Min	Typ	Max	Unit	Conditions
All Circuits						
Stand-by Current	I_{CCST}	-	0	3.0	μA	$V_{PS}=0V$
Circuit Current	I_{CC}	-	1.3	2.0	mA	$V_{PS}=3V$ with no signal, no load
Control Input (IN=PS, INPUT1 to INPUT45, STROBE, SCLK, SDATA)						
High Level Input Voltage	V_{INH}	2.0	-	V_{CC}	V	
Low Level Input Voltage	V_{INL}	0	-	0.7	V	
High Level Input Current 1	I_{INH1}	15	30	60	μA	V_{INH1} (PS, INPUTx) =3V
High Level Input Current 2	I_{INH2}	7.5	15	30	μA	V_{INH2} (STROBE, SCLK, SDATA) =3V
Low Level Input Current	I_{INL}	-1	0	-	μA	$V_{INL}=0V$
Under Voltage Locked Out (UVLO)						
UVLO Voltage	V_{UVLO}	1.6	-	2.4	V	
Constant-Voltage Drive / Full-ON Drive Block (Channel 1 to Channel 3)						
Output ON-Resistance	R_{ON}	-	1.40	1.75	Ω	$I_{OUT}=\pm 400mA$, High & Low-side Total
Output High Voltage 1	V_{OH1}	1.35	1.50	1.65	V	DACx:010100, $R_L=20\Omega$
Output High Voltage 2	V_{OH2}	2.85	3.00	3.15	V	DACx:101000, $R_L=20\Omega$
Output High Voltage 3	V_{OH3}	4.49	4.73	4.96	V	DACx:111111, $R_L=20\Omega$
DAC Resolution	DV_{RES}	-	6	-	BITS	75mV/LSB
Differential Nonlinearity	DV_{DNL}	-1	-	+1	LSB	
Integral Nonlinearity	DV_{INL}	-2	-	+2	LSB	
Min Voltage of DAC Setting	DV_{RNG}	1.5	-	-	V	DACx:010100
Constant-Voltage Drive / Constant-Current Drive / Full-ON Drive Block (Channel 4)						
Output ON-Resistance	R_{ON}	-	1.40	1.75	Ω	$I_{OUT}=\pm 400mA$, High & Low-side Total
Output High Voltage 1	V_{OH1}	1.35	1.50	1.65	V	DACV4:010100, $R_L=20\Omega$
Output High Voltage 2	V_{OH2}	2.85	3.00	3.15	V	DACV4:101000, $R_L=20\Omega$
Output High Voltage 3	V_{OH3}	4.49	4.73	4.96	V	DACV4:111111, $R_L=20\Omega$
DAC Resolution	DV_{RES}	-	6	-	BITS	75mV/LSB
Differential Nonlinearity	DV_{DNL}	-1	-	+1	LSB	
Integral Nonlinearity	DV_{INL}	-2	-	+2	LSB	
Min Voltage of DAC Setting	DV_{RNG}	1.5	-	-	V	DACV4:010100
RNF Voltage 1	V_{RNF1}	40	50	60	mV	DACI4:001010, $R_{NF}=0.5\Omega$, $R_L=10\Omega$
RNF Voltage 2	V_{RNF2}	94	99	104	mV	DACI4:010100, $R_{NF}=0.5\Omega$, $R_L=10\Omega$
RNF Voltage 3	V_{RNF3}	178	198	218	mV	DACI4:101000, $R_{NF}=0.5\Omega$, $R_L=10\Omega$
DAC Resolution	DI_{RES}	-	6	-	BITS	5mV/LSB
Differential Nonlinearity	DI_{DNL}	-1	-	+1	LSB	
Integral Nonlinearity	DI_{INL}	-2	-	+2	LSB	
Min Voltage of DAC Setting	DI_{RNG}	50	-	-	mV	DACI4:001010
Constant-Current Drive Block (Channel 5)						
Output ON-Resistance	R_{ON}	-	1.40	1.75	Ω	$I_{OUT}=\pm 400mA$, High & Low-side Total
RNF Voltage 1	V_{RNF1}	38	48	58	mV	DAC5:001010, $R_{NF}=0.5\Omega$, $R_L=10\Omega$
RNF Voltage 2	V_{RNF2}	91	96	101	mV	DAC5:010100, $R_{NF}=0.5\Omega$, $R_L=10\Omega$
RNF Voltage 3	V_{RNF3}	172	192	212	mV	DAC5:101000, $R_{NF}=0.5\Omega$, $R_L=10\Omega$
DAC Resolution	DI_{RES}	-	6	-	BITS	5mV/LSB
Differential Nonlinearity	DI_{DNL}	-1	-	+1	LSB	
Integral Nonlinearity	DI_{INL}	-2	-	+2	LSB	
Min Voltage of DAC Setting	DI_{RNG}	50	-	-	mV	DAC5:001010

Typical Performance Curves (Reference Data)

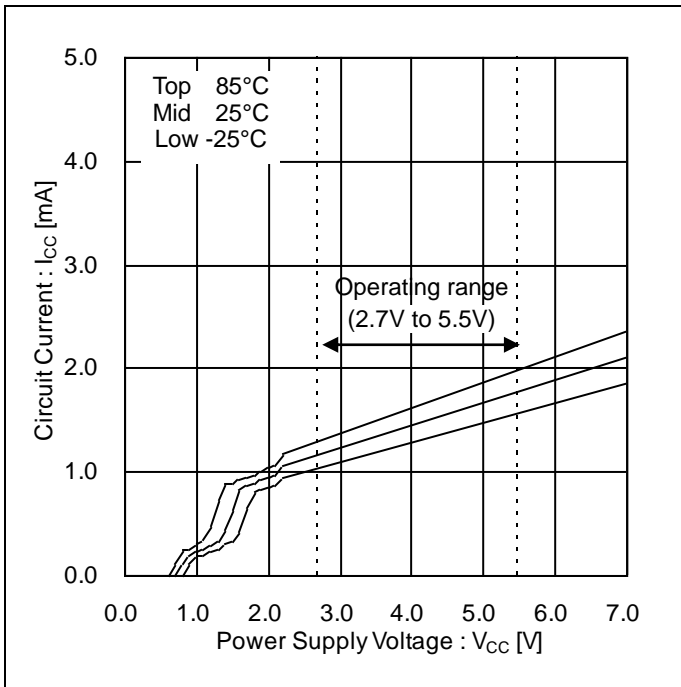

Figure 1.
Circuit Current vs Power Supply Voltage

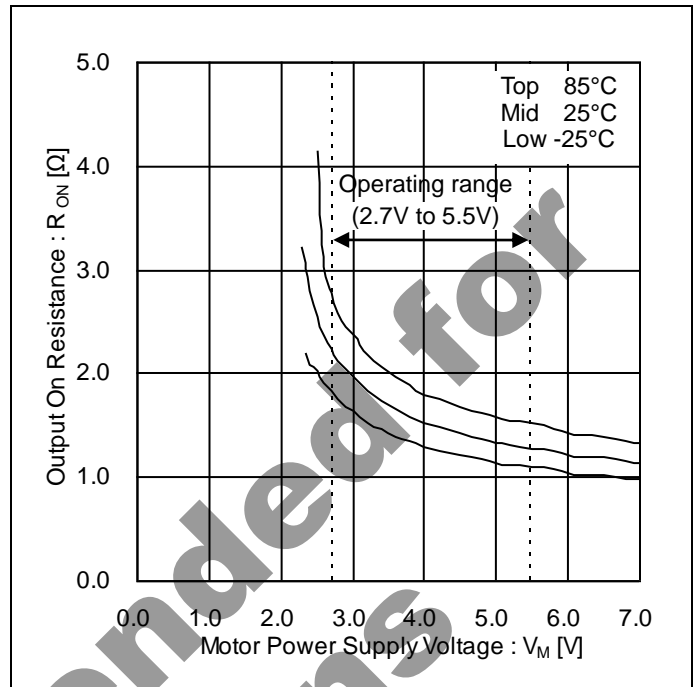

Figure 2.
Output ON-Resistance vs Motor Power Supply Voltage
(Channel 1 to Channel 3)

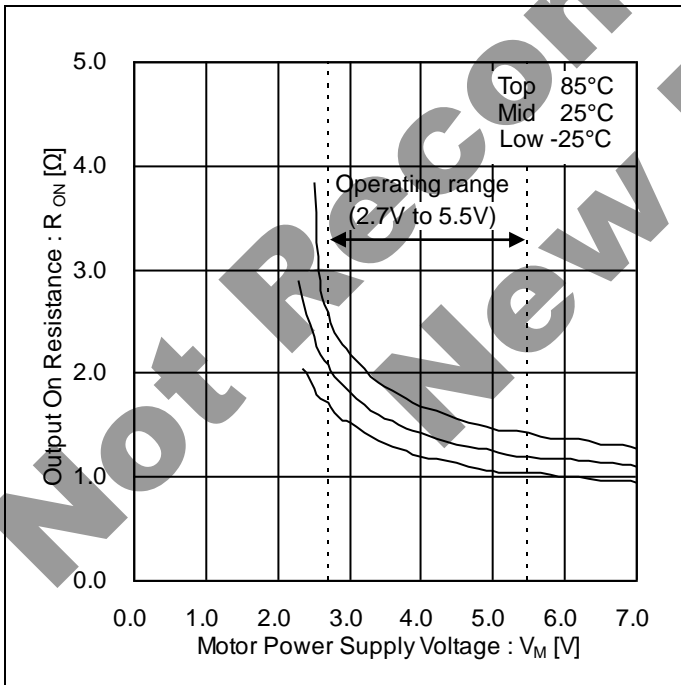

Figure 3.
Output ON-Resistance vs Motor Power Supply Voltage
(Channel 4 & Channel 5)

Timing chart

Serial Input (STROBE, SCLK, and SDATA)

The BD6370GUL provides the D/A converter and 3-line serial interface for setting output modes.

SDATA is sent to the internal shift register during the STROBE low interval at the SCLK rising edge. Shift register data (Bit[B] to Bit[0]) is written to the internal 12-bit memory simultaneously with STROBE rising edge, according to the addresses stored in Bit[E], Bit[D], and Bit[C]. The input first serial data is Bit[E] and the last is Bit[0].

In case of the exclusive drive mode (MODE13=1 and/or MODE23=1), each serial bit of DAC12 and DAC3 should be input the same data.

Cancel power-saving mode after turning on power supply V_{CC} and V_M . All serial data will be reset to 0 when the PS pin voltage changes to Low-level, because PS pin combines with power-saving function and serial data clear function block. These data will be also reset to 0 when the UVLO or TSD circuit operates.

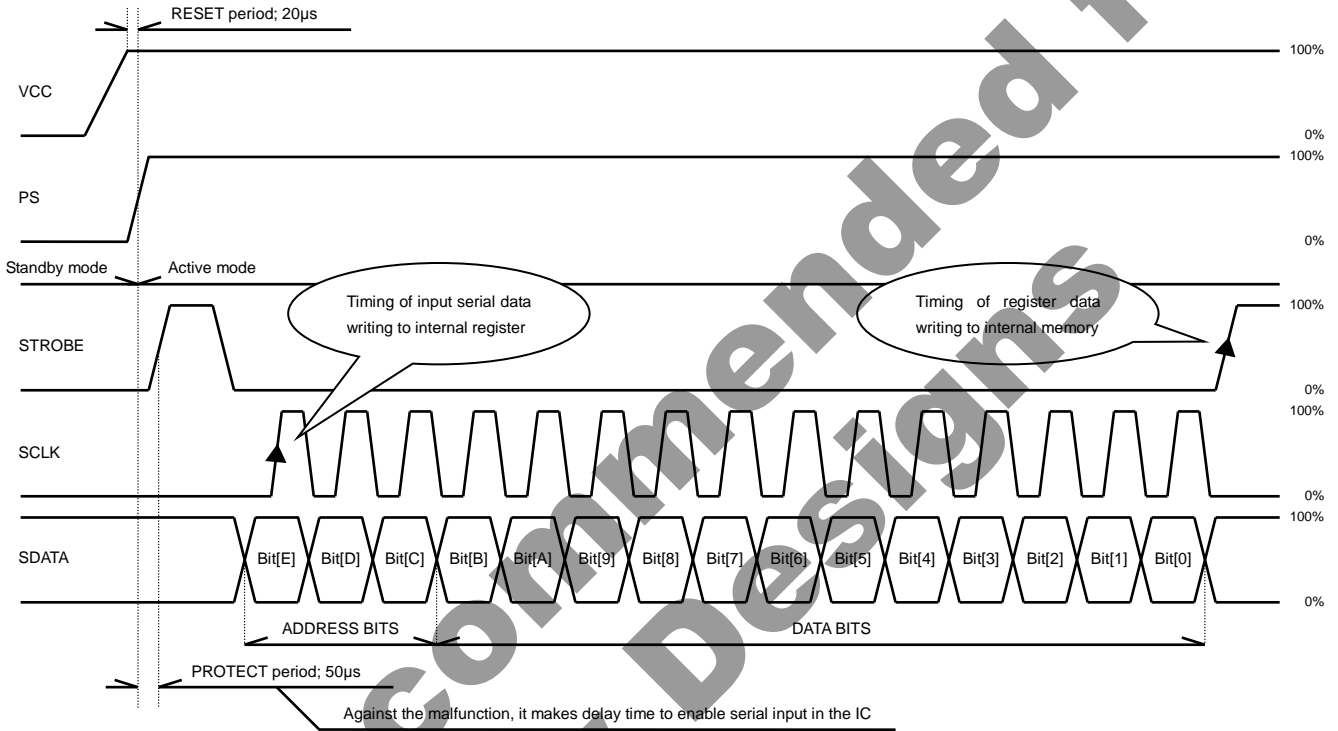

Figure 4.
Sequence of Serial Control Input

Timing chart – continued

Serial Register Bit Map

The Bit Map is consisted of 5 addresses and 60 data. There are some prohibited bits in the serial data MODExx, so set no kind of cases. (See the I/O Truth Table (Selection of Exclusive Drive Mode); p.11/32)

Must not set TEST bits and initial data must be held at 0 (GND).

Table 1. Bit Map (ADDRESS BIT)

No.	ADDRESS BIT		
	Bit[E]	Bit[D]	Bit[C]
00H	0	0	0
01H	0	0	1
02H	0	1	0
03H	0	1	1
04H	1	0	0

Table 2. Bit Map (DATA BIT)

No.	DATA BIT											
	Bit[B]	Bit[A]	Bit[9]	Bit[8]	Bit[7]	Bit[6]	Bit[5]	Bit[4]	Bit[3]	Bit[2]	Bit[1]	Bit[0]
00H	TEST	TEST	MODE 45	MODE 34	MODE 23	MODE 13	MODE 3C	MODE 3B	MODE 3A	MODE 12C	MODE 12B	MODE 12A
01H	DAC 12[5]	DAC 12[4]	DAC 12[3]	DAC 12[2]	DAC 12[1]	DAC 12[0]	MODE 5B	MODE 5A	MODE 4D	MODE 4C	MODE 4B	MODE 4A
02H	DAC 5[5]	DAC 5[4]	DAC 5[3]	DAC 5[2]	DAC 5[1]	DAC 5[0]	DAC 3[5]	DAC 3[4]	DAC 3[3]	DAC 3[2]	DAC 3[1]	DAC 3[0]
03H	DAC V4[5]	DAC V4[4]	DAC V4[3]	DAC V4[2]	DAC V4[1]	DAC V4[0]	DAC I4[5]	DAC I4[4]	DAC I4[3]	DAC I4[2]	DAC I4[1]	DAC I4[0]
04H	TEST	TEST	IN5B	IN5A	IN4B	IN4A	IN3B	IN3A	IN2B	IN2A	IN1B	IN1A

Table 3. Bit Function

Bit Name	Function
MODExA (x=1 to 5)	Control mode selection for channel 1 to channel 5
MODExB (x=1 to 5)	Control mode selection for channel 1 to channel 5
MODExC (x=1 to 3)	Choice of Constant-Voltage or Full-ON mode for channel 1 to channel 3
MODExD (x=4)	Choice of Constant-Voltage or Constant-Current or Full-ON mode for channel 4
MODE13	Exclusive drive mode selection for OUT1A-OUT3A
MODE23	Exclusive drive mode selection for OUT2A-OUT3B
MODE34	Choice to connect channel 3 or channel 4 via INPUT34 pin
MODE45	Choice to connect channel 4 or channel 5 via INPUT45 pin
INxA (x=1 to 5)	Control mode selection for channel 1 to channel 5
INxB (x=1 to 5)	Control mode selection for channel 1 to channel 5
DACx[y] (x=12 to 5, y=0 to 5)	D/A Converter output selection for channel 1 to channel 5
TEST	TEST BIT (All bits must be held at GND)

Timing chart – continued

Table 4. DATA BIT MAP [000]

ADR.	DATA BIT											
	Bit[B]	Bit[A]	Bit[9]	Bit[8]	Bit[7]	Bit[6]	Bit[5]	Bit[4]	Bit[3]	Bit[2]	Bit[1]	Bit[0]
000	TEST (Note 5)	TEST (Note 5)	MODE 45	MODE 34	MODE 23	MODE 13	MODE 3C	MODE 3B	MODE 3A	MODE 12C	MODE 12B	MODE 12A

(Note 5) Must be held at 0 (GND)

Refer to the p.19/32 to p.21/32 about MODE12A & MODE12B.
Refer to the p.20/32 about MODE3A & MODE3B.

Table 5. I/O Truth Table for Drive Mode Selection (Channel 1 to Channel 3)

Bit[5]	Bit[2]	Drive Mode for Output Terminals			Note
MODE3C	MODE12C	Channel 3	Channel 2	Channel 1	
0	-	Full-ON	-	-	DAC3: 6'b111111
1	-	Constant-Voltage	-	-	
-	0	-	Full-ON	Full-ON	DAC12: 6'b111111
-	1	-	Constant-Voltage	Constant-Voltage	

Table 6. I/O Truth Table for Exclusive Drive Mode Selection

Bit[9]	Bit[8]	Bit[7]	Bit[6]	Input Pins Correspond to Outputs				Note	
MODE 45	MODE 34	MODE 23	MODE 13	INPUT 45	INPUT 34	INPUT 2	INPUT 1	Opened Output Terminals	Ref No. (Next)
0	0	0	0	OUT 4A-4B	OUT 3A-3B	OUT 2A-2B	OUT 1A-1B	OUT5A, 5B	1
0 (Note 6)	0	0	1						
0 (Note 6)	0	1	0						
0 (Note 6)	0	1	1						
0	1	0	0	OUT 5A-5B	OUT 4A-4B	OUT 2A-2B	OUT 1A-1B	OUT3A, 3B	2
0	1	0	1	OUT 5A-5B	OUT 4A-4B	OUT 2A-2B	OUT 1A-3A	OUT1B, 3B	3
0	1	1	0	OUT 5A-5B	OUT 4A-4B	OUT 2A-3B	OUT 1A-1B	OUT2B, 3A	4
0	1	1	1	OUT 5A-5B	OUT 4A-4B	OUT 2A-3B	OUT 1A-3A	OUT1B, 2B	5
1	0	0	0	OUT 5A-5B	OUT 3A-3B	OUT 2A-2B	OUT 1A-1B	OUT4A, 4B	6
1 (Note 6)	0	0	1						
1 (Note 6)	0	1	0						
1 (Note 6)	0	1	1						
1 (Note 6)	1	0	0						
1 (Note 6)	1	0	1						
1 (Note 6)	1	1	0						
1 (Note 6)	1	1	1						

(Note 6) Must not set data

Timing chart – continued

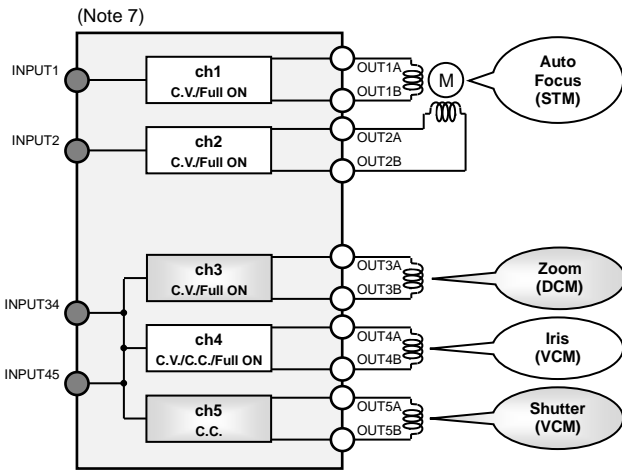

Figure 5.
Example of Standard Model
(Ref. No.1, 2, and 6)

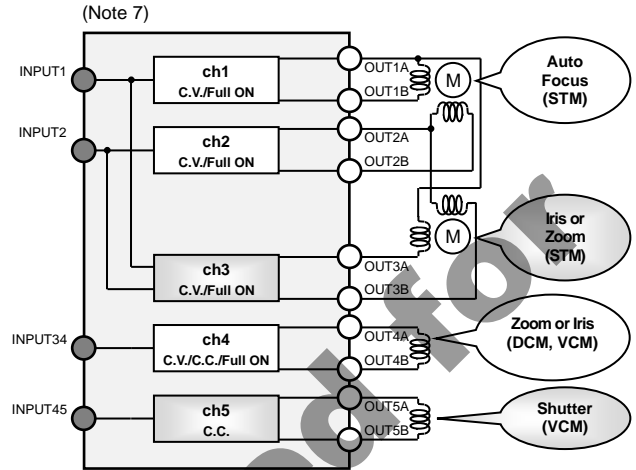

Figure 6.
Example of High Performance Model
(Ref. No.2 and 5)

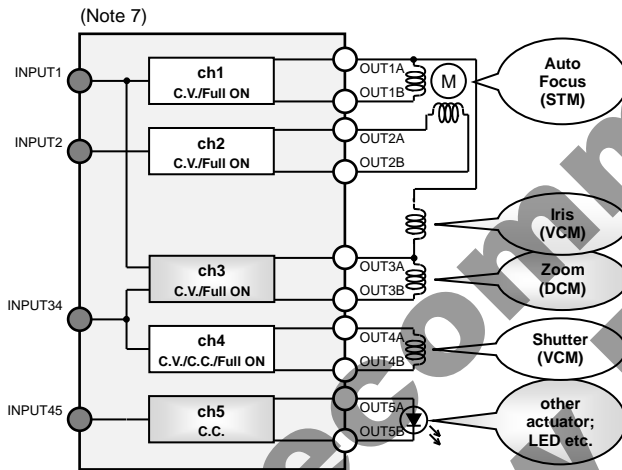

Figure 7.
Example 1 of Standard Model and
another Actuator
(Ref. No.3 and 6)

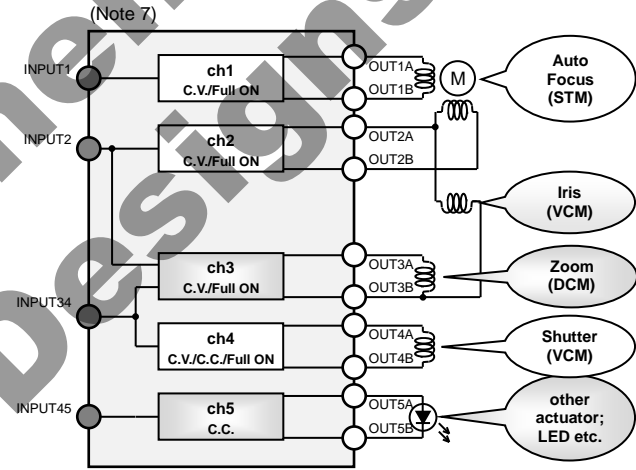

Figure 8.
Example 2 of Standard Model and
another Actuator
(Ref. No.4 and 6)

(Note 7)
C.V.=Constant-Voltage drive mode
Full ON=Full-ON drive mode
C.C.=Constant-Current drive mode
STM=Stepping Motor
DCM=DC Motor
VCM=Voice Coil Motor

Timing chart – continued

Table 7. DATA BIT MAP [001]

ADR.	DATA BIT											
	Bit[B]	Bit[A]	Bit[9]	Bit[8]	Bit[7]	Bit[6]	Bit[5]	Bit[4]	Bit[3]	Bit[2]	Bit[1]	Bit[0]
001	DAC 12[5]	DAC 12[4]	DAC 12[3]	DAC 12[2]	DAC 12[1]	DAC 12[0]	MODE 5B	MODE 5A	MODE 4D	MODE 4C	MODE 4B	MODE 4A

Refer to the p.22/32 about MODE4A & MODE4B.
Refer to the p.23/32 about MODE5A & MODE5B.

Table 8. Function Table for Output Drive Mode Selection (Channel 4)

Bit[3] MODE4D	Bit[2] MODE4C	Drive Mode	Note
0	0	Full-ON	DACV4=DACI4: 6'b111111, RNF4 pin should be directly connected to ground
0	1	Full-ON	DACV4=DACI4: 6'b111111, RNF4 pin should be directly connected to ground
1	0	Constant Voltage	DACI4: 6'b111111, RNF4 pin should be directly connected to ground
1	1	Constant Current	DACV4: 6'b111111, RNF4 pin with resistor should be connected to ground

Timing chart – continued

Table 9. Function Table for Output Voltage in case of Constant Voltage Mode (Channel 1 & Channel 2)

Bit[B]	Bit[A]	Bit[9]	Bit[8]	Bit[7]	Bit[6]	DAC12 Voltage; V_{DAC12} [V]	Output High Voltage; V_{OH} [V]
DAC12[5]	DAC12[4]	DAC12[3]	DAC12[2]	DAC12[1]	DAC12[0]		
0	1	0	1	0	0	0.188	1.500
0	1	0	1	0	1	0.197	1.575
0	1	0	1	1	0	0.206	1.650
0	1	0	1	1	1	0.216	1.725
0	1	1	0	0	0	0.225	1.800
0	1	1	0	0	1	0.234	1.875
0	1	1	0	1	0	0.244	1.950
0	1	1	0	1	1	0.253	2.025
0	1	1	1	0	0	0.263	2.100
0	1	1	1	0	1	0.272	2.175
0	1	1	1	1	0	0.281	2.250
0	1	1	1	1	1	0.291	2.325
1	0	0	0	0	0	0.300	2.400
1	0	0	0	0	1	0.309	2.475
1	0	0	0	1	0	0.319	2.550
1	0	0	0	1	1	0.328	2.625
1	0	0	1	0	0	0.338	2.700
1	0	0	1	0	1	0.347	2.775
1	0	0	1	1	0	0.356	2.850
1	0	0	1	1	1	0.366	2.925
1	0	1	0	0	0	0.375	3.000
1	0	1	0	0	1	0.384	3.075
1	0	1	0	1	0	0.394	3.150
1	0	1	0	1	1	0.403	3.225
1	0	1	1	0	0	0.413	3.300
1	0	1	1	0	1	0.422	3.375
1	0	1	1	1	0	0.431	3.450
1	0	1	1	1	1	0.441	3.525
1	1	0	0	0	0	0.450	3.600
1	1	0	0	0	1	0.459	3.675
1	1	0	0	1	0	0.469	3.750
1	1	0	0	1	1	0.478	3.825
1	1	0	1	0	0	0.488	3.900
1	1	0	1	0	1	0.497	3.975
1	1	0	1	1	0	0.506	4.050
1	1	0	1	1	1	0.516	4.125
1	1	1	0	0	0	0.525	4.200
1	1	1	0	0	1	0.534	4.275
1	1	1	0	1	0	0.544	4.350
1	1	1	0	1	1	0.553	4.425
1	1	1	1	0	0	0.563	4.500
1	1	1	1	0	1	0.572	4.575
1	1	1	1	1	0	0.581	4.650
1	1	1	1	1	1	0.591	4.725

Timing chart – continued

Table 10. DATA BIT MAP [010]

ADR.	DATA BIT											
	Bit[B]	Bit[A]	Bit[9]	Bit[8]	Bit[7]	Bit[6]	Bit[5]	Bit[4]	Bit[3]	Bit[2]	Bit[1]	Bit[0]
010	DAC 5[5]	DAC 5[4]	DAC 5[3]	DAC 5[2]	DAC 5[1]	DAC 5[0]	DAC 3[5]	DAC 3[4]	DAC 3[3]	DAC 3[2]	DAC 3[1]	DAC 3[0]

Table 11. Function Table for Output Voltage in case of Constant Voltage Mode (Channel 3)

Bit[5]	Bit[4]	Bit[3]	Bit[2]	Bit[1]	Bit[0]	DAC3 Voltage; V_{DAC3} [V]	Output High Voltage, V_{OH} [V]
DAC3[5]	DAC3[4]	DAC3[3]	DAC3[2]	DAC3[1]	DAC3[0]		
0	1	0	1	0	0	0.188	1.500
0	1	0	1	0	1	0.197	1.575
0	1	0	1	1	0	0.206	1.650
0	1	0	1	1	1	0.216	1.725
0	1	1	0	0	0	0.225	1.800
0	1	1	0	0	1	0.234	1.875
0	1	1	0	1	0	0.244	1.950
0	1	1	0	1	1	0.253	2.025
0	1	1	1	0	0	0.263	2.100
0	1	1	1	0	1	0.272	2.175
0	1	1	1	1	0	0.281	2.250
0	1	1	1	1	1	0.291	2.325
1	0	0	0	0	0	0.300	2.400
1	0	0	0	0	1	0.309	2.475
1	0	0	0	1	0	0.319	2.550
1	0	0	0	1	1	0.328	2.625
1	0	0	1	0	0	0.338	2.700
1	0	0	1	0	1	0.347	2.775
1	0	0	1	1	0	0.356	2.850
1	0	0	1	1	1	0.366	2.925
1	0	1	0	0	0	0.375	3.000
1	0	1	0	0	1	0.384	3.075
1	0	1	0	1	0	0.394	3.150
1	0	1	0	1	1	0.403	3.225
1	0	1	1	0	0	0.413	3.300
1	0	1	1	0	1	0.422	3.375
1	0	1	1	1	0	0.431	3.450
1	0	1	1	1	1	0.441	3.525
1	1	0	0	0	0	0.450	3.600
1	1	0	0	0	1	0.459	3.675
1	1	0	0	1	0	0.469	3.750
1	1	0	0	1	1	0.478	3.825
1	1	0	1	0	0	0.488	3.900
1	1	0	1	0	1	0.497	3.975
1	1	0	1	1	0	0.506	4.050
1	1	0	1	1	1	0.516	4.125
1	1	1	0	0	0	0.525	4.200
1	1	1	0	0	1	0.534	4.275
1	1	1	0	1	0	0.544	4.350
1	1	1	0	1	1	0.553	4.425
1	1	1	1	0	0	0.563	4.500
1	1	1	1	0	1	0.572	4.575
1	1	1	1	1	0	0.581	4.650
1	1	1	1	1	1	0.591	4.725

Timing chart – continued

Table 12. Function Table for Output Current in case of Constant Current Mode (Channel 5)

Bit[B]	Bit[A]	Bit[9]	Bit[8]	Bit[7]	Bit[6]	DAC5 Voltage V _{DAC5} [mV]	R _{RNF5} =0.5Ω Current [mA]	R _{RNF5} =1.0Ω Current [mA]
DAC5[5]	DAC5[4]	DAC5[3]	DAC5[2]	DAC5[1]	DAC5[0]			
0	0	1	0	1	0	50	96	49
0	0	1	0	1	1	55	105	54
0	0	1	1	0	0	60	115	59
0	0	1	1	0	1	65	125	64
0	0	1	1	1	0	70	134	68
0	0	1	1	1	1	75	144	73
0	1	0	0	0	0	80	153	78
0	1	0	0	0	1	85	163	83
0	1	0	0	1	0	90	172	88
0	1	0	0	1	1	95	182	93
0	1	0	1	0	0	100	192	98
0	1	0	1	0	1	105	201	103
0	1	0	1	1	0	110	211	108
0	1	0	1	1	1	115	220	113
0	1	1	0	0	0	120	230	117
0	1	1	0	0	1	125	239	122
0	1	1	0	1	0	130	249	127
0	1	1	0	1	1	135	259	132
0	1	1	1	0	0	140	268	137
0	1	1	1	0	1	145	278	142
0	1	1	1	1	0	150	287	147
0	1	1	1	1	1	155	297	152
1	0	0	0	0	0	160	307	157
1	0	0	0	0	1	165	316	161
1	0	0	0	1	0	170	326	166
1	0	0	0	1	1	175	336	171
1	0	0	1	0	0	180	345	176
1	0	0	1	0	1	185	355	181
1	0	0	1	1	0	190	364	186
1	0	0	1	1	1	195	374	191
1	0	1	0	0	0	200	383	196
1	0	1	0	0	1	205	393	201
1	0	1	0	1	0	210	Over Operating Condition	205
1	0	1	0	1	1	215		210
1	0	1	1	0	0	220		216
1	0	1	1	0	1	225		220
1	0	1	1	1	0	230		225
1	0	1	1	1	1	235		230
1	1	0	0	0	0	240		235
1	1	0	0	0	1	245		240
1	1	0	0	1	0	250		245
1	1	0	0	1	1	255		250
1	1	0	1	0	0	260		254
1	1	0	1	0	1	265		259
1	1	0	1	1	0	270		264
1	1	0	1	1	1	275		269
1	1	1	0	0	0	280		274
1	1	1	0	0	1	285		279
1	1	1	0	1	0	290		284
1	1	1	0	1	1	295		289
1	1	1	1	0	0	300		294
1	1	1	1	0	1	305		298
1	1	1	1	1	0	310		303
1	1	1	1	1	1	315		308

Timing chart – continued

Table 13. DATA BIT MAP [011]

ADR.	DATA BIT											
	Bit[B]	Bit[A]	Bit[9]	Bit[8]	Bit[7]	Bit[6]	Bit[5]	Bit[4]	Bit[3]	Bit[2]	Bit[1]	Bit[0]
011	DAC V4[5]	DAC V4[4]	DAC V4[3]	DAC V4[2]	DAC V4[1]	DAC V4[0]	DAC I4[5]	DAC I4[4]	DAC I4[3]	DAC I4[2]	DAC I4[1]	DAC I4[0]

Table 14. Function Table for Output Voltage in case of Constant Voltage Mode (Channel 4)

Bit[B]	Bit[A]	Bit[9]	Bit[8]	Bit[7]	Bit[6]	DACV4 Voltage V_{DACV4} [V]	Output High Voltage, V_{OH} [V]
DACV4[5]	DACV4[4]	DACV4[3]	DACV4[2]	DACV4[1]	DACV4[0]		
0	1	0	1	0	0	0.188	1.500
0	1	0	1	0	1	0.197	1.575
0	1	0	1	1	0	0.206	1.650
0	1	0	1	1	1	0.216	1.725
0	1	1	0	0	0	0.225	1.800
0	1	1	0	0	1	0.234	1.875
0	1	1	0	1	0	0.244	1.950
0	1	1	0	1	1	0.253	2.025
0	1	1	1	0	0	0.263	2.100
0	1	1	1	0	1	0.272	2.175
0	1	1	1	1	0	0.281	2.250
0	1	1	1	1	1	0.291	2.325
1	0	0	0	0	0	0.300	2.400
1	0	0	0	0	1	0.309	2.475
1	0	0	0	1	0	0.319	2.550
1	0	0	0	1	1	0.328	2.625
1	0	0	1	0	0	0.338	2.700
1	0	0	1	0	1	0.347	2.775
1	0	0	1	1	0	0.356	2.850
1	0	0	1	1	1	0.366	2.925
1	0	1	0	0	0	0.375	3.000
1	0	1	0	0	1	0.384	3.075
1	0	1	0	1	0	0.394	3.150
1	0	1	0	1	1	0.403	3.225
1	0	1	1	0	0	0.413	3.300
1	0	1	1	0	1	0.422	3.375
1	0	1	1	1	0	0.431	3.450
1	0	1	1	1	1	0.441	3.525
1	1	0	0	0	0	0.450	3.600
1	1	0	0	0	1	0.459	3.675
1	1	0	0	1	0	0.469	3.750
1	1	0	0	1	1	0.478	3.825
1	1	0	1	0	0	0.488	3.900
1	1	0	1	0	1	0.497	3.975
1	1	0	1	1	0	0.506	4.050
1	1	0	1	1	1	0.516	4.125
1	1	1	0	0	0	0.525	4.200
1	1	1	0	0	1	0.534	4.275
1	1	1	0	1	0	0.544	4.350
1	1	1	0	1	1	0.553	4.425
1	1	1	1	0	0	0.563	4.500
1	1	1	1	0	1	0.572	4.575
1	1	1	1	1	0	0.581	4.650
1	1	1	1	1	1	0.591	4.725

Timing chart – continued

Table 15. Function Table for Output Current in case of Constant Current Mode (Channel 4)

Bit[5]	Bit[4]	Bit[3]	Bit[2]	Bit[1]	Bit[0]	DACI4 Voltage V_{DACI4} [mV]	$R_{RNF14}=0.5\Omega$ Current [mA]	$R_{RNF14}=1.0\Omega$ Current [mA]
DACI4[5]	DACI4[4]	DACI4[3]	DACI4[2]	DACI4[1]	DACI4[0]			
0	0	1	0	1	0	50	99	50
0	0	1	0	1	1	55	109	55
0	0	1	1	0	0	60	119	60
0	0	1	1	0	1	65	129	65
0	0	1	1	1	0	70	139	70
0	0	1	1	1	1	75	149	75
0	1	0	0	0	0	80	159	80
0	1	0	0	0	1	85	169	85
0	1	0	0	1	0	90	179	90
0	1	0	0	1	1	95	188	95
0	1	0	1	0	0	100	198	100
0	1	0	1	0	1	105	208	105
0	1	0	1	1	0	110	218	110
0	1	0	1	1	1	115	228	115
0	1	1	0	0	0	120	238	120
0	1	1	0	0	1	125	248	125
0	1	1	0	1	0	130	258	129
0	1	1	0	1	1	135	268	134
0	1	1	1	0	0	140	278	139
0	1	1	1	0	1	145	288	144
0	1	1	1	1	0	150	298	149
0	1	1	1	1	1	155	308	154
1	0	0	0	0	0	160	317	159
1	0	0	0	0	1	165	327	164
1	0	0	0	1	0	170	337	169
1	0	0	0	1	1	175	347	174
1	0	0	1	0	0	180	357	179
1	0	0	1	0	1	185	367	184
1	0	0	1	1	0	190	377	189
1	0	0	1	1	1	195	387	194
1	0	1	0	0	0	200	397	199
1	0	1	0	0	1	205	Over Operating Condition	204
1	0	1	0	1	0	210		209
1	0	1	0	1	1	215		214
1	0	1	1	0	0	220		219
1	0	1	1	0	1	225		224
1	0	1	1	1	0	230		229
1	0	1	1	1	1	235		234
1	1	0	0	0	0	240		239
1	1	0	0	0	1	245		244
1	1	0	0	1	0	250		249
1	1	0	0	1	1	255		254
1	1	0	1	0	0	260		259
1	1	0	1	0	1	265		264
1	1	0	1	1	0	270		269
1	1	0	1	1	1	275		274
1	1	1	0	0	0	280		279
1	1	1	0	0	1	285		284
1	1	1	0	1	0	290		289
1	1	1	0	1	1	295		294
1	1	1	1	0	0	300		299
1	1	1	1	0	1	305		304
1	1	1	1	1	0	310		309
1	1	1	1	1	1	315		314

Timing chart – continued

Table 16. DATA BIT MAP [100]

ADR.	DATA BIT											
	Bit[B]	Bit[A]	Bit[9]	Bit[8]	Bit[7]	Bit[6]	Bit[5]	Bit[4]	Bit[3]	Bit[2]	Bit[1]	Bit[0]
100	TEST (Note 8)	TEST (Note 8)	IN5B	IN5A	IN4B	IN4A	IN3B	IN3A	IN2B	IN2A	IN1B	IN1A

(Note 8) Must be held at 0 (GND)

Table 17. I/O Truth Table (Channel 1)

Serial Interface Bit				INPUT		OUTPUT			
MODE 23	MODE 13	MODE 12B	MODE 12A	IN1B	IN1A	INPUT1	OUT1A	OUT1B	Output Mode (Note 9)
PWM Drive Mode via INPUT1 Pin									
0	0	0	0	0	0	X	Z	Z	Open
0	0	0	0	0	1	L	L	L	Short Brake
0	0	0	0	0	1	H	H	L	CW
0	0	0	0	1	0	L	L	L	Short Brake
0	0	0	0	1	0	H	L	H	CCW
0	0	0	0	1	1	X	L	L	Short Brake
PWM Drive Mode via INPUT1 Pin									
0	0	0	1	0	0	X	Z	Z	Open
0	0	0	1	0	1	L	H	L	CW
0	0	0	1	0	1	H	L	L	Short Brake
0	0	0	1	1	0	L	L	H	CCW
0	0	0	1	1	0	H	L	L	Short Brake
0	0	0	1	1	1	X	L	L	Short Brake
CW / CCW Drive Mode via INPUT1 Pin									
0	0	1	0	X	0	X	Z	Z	Open
0	0	1	0	0	1	L	L	H	CCW
0	0	1	0	0	1	H	H	L	CW
0	0	1	0	1	1	X	L	L	Short Brake
CW / CCW Drive Mode via INPUT1 Pin									
0	0	1	1	X	0	X	Z	Z	Open
0	0	1	1	0	1	L	H	L	CW
0	0	1	1	0	1	H	L	H	CCW
0	0	1	1	1	1	X	L	L	Short Brake

L: Low, H: High, X: Don't care, Z: Hi impedance

(Note 9) CW: Current flows from OUT1A to OUT1B, CCW: Current flows from OUT1B to OUT1A

Timing chart – continued

Table 18. I/O Truth Table (Channel 2)

Serial Interface Bit						INPUT	OUTPUT		
MODE 23	MODE 13	MODE 12B	MODE 12A	IN2B	IN2A	INPUT2	OUT2A	OUT2B	Output Mode (Note 10)
PWM Drive Mode via INPUT2 Pin									
0	0	0	0	0	0	X	Z	Z	Open
0	0	0	0	0	1	L	L	L	Short Brake
0	0	0	0	0	1	H	H	L	CW
0	0	0	0	1	0	L	L	L	Short Brake
0	0	0	0	1	0	H	L	H	CCW
0	0	0	0	1	1	X	L	L	Short Brake
PWM Drive Mode via INPUT2 Pin									
0	0	0	1	0	0	X	Z	Z	Open
0	0	0	1	0	1	L	H	L	CW
0	0	0	1	0	1	H	L	L	Short Brake
0	0	0	1	1	0	L	L	H	CCW
0	0	0	1	1	0	H	L	L	Short Brake
0	0	0	1	1	1	X	L	L	Short Brake
CW / CCW Drive Mode via INPUT2 Pin									
0	0	1	0	X	0	X	Z	Z	Open
0	0	1	0	0	1	L	L	H	CCW
0	0	1	0	0	1	H	H	L	CW
0	0	1	0	1	1	X	L	L	Short Brake
CW / CCW Drive Mode via INPUT2 Pin									
0	0	1	1	X	0	X	Z	Z	Open
0	0	1	1	0	1	L	H	L	CW
0	0	1	1	0	1	H	L	H	CCW
0	0	1	1	1	1	X	L	L	Short Brake

L: Low, H: High, X: Don't care, Z: Hi impedance

(Note 10) CW: Current flows from OUT2A to OUT2B, CCW: Current flows from OUT2B to OUT2A

Table 19. I/O Truth Table (Channel 3)

Serial Interface Bit						INPUT	OUTPUT		
MODE 34	MODE 23	MODE 3B	MODE 3A	IN3B	IN3A	INPUT34	OUT3A	OUT3B	Output Mode (Note 11)
PWM Drive Mode via INPUT34 Pin									
0	0	0	0	0	0	X	Z	Z	Open
0	0	0	0	0	1	L	L	L	Short Brake
0	0	0	0	0	1	H	H	L	CW
0	0	0	0	1	0	L	L	L	Short Brake
0	0	0	0	1	0	H	L	H	CCW
0	0	0	0	1	1	X	L	L	Short Brake
PWM Drive Mode via INPUT34 Pin									
0	0	0	1	0	0	X	Z	Z	Open
0	0	0	1	0	1	L	H	L	CW
0	0	0	1	0	1	H	L	L	Short Brake
0	0	0	1	1	0	L	L	H	CCW
0	0	0	1	1	0	H	L	L	Short Brake
0	0	0	1	1	1	X	L	L	Short Brake
CW / CCW Drive Mode via INPUT34 Pin									
0	0	1	0	X	0	X	Z	Z	Open
0	0	1	0	0	1	L	L	H	CCW
0	0	1	0	0	1	H	H	L	CW
0	0	1	0	1	1	X	L	L	Short Brake
CW / CCW Drive Mode via INPUT34 Pin									
0	0	1	1	X	0	X	Z	Z	Open
0	0	1	1	0	1	L	H	L	CW
0	0	1	1	0	1	H	L	H	CCW
0	0	1	1	1	1	X	L	L	Short Brake

L: Low, H: High, X: Don't care, Z: Hi impedance

(Note 11) CW: Current flows from OUT3A to OUT3B, CCW: Current flows from OUT3B to OUT3A

Timing chart – continued

Table 20. I/O Truth Table (Exclusive Drive Mode for OUT1A-OUT3A)

Serial Interface Bit						INPUT	OUTPUT		
MODE 23	MODE 13	MODE 12B	MODE 12A	IN1B	IN1A	INPUT1	OUT1A	OUT3A	Output Mode (Note 12)
PWM Drive Mode via INPUT1 Pin									
ANY	1	0	0	0	0	X	Z	Z	Open
ANY	1	0	0	0	1	L	L	L	Short Brake
ANY	1	0	0	0	1	H	H	L	CW
ANY	1	0	0	1	0	L	L	L	Short Brake
ANY	1	0	0	1	0	H	L	H	CCW
ANY	1	0	0	1	1	X	L	L	Short Brake
PWM Drive Mode via INPUT1 Pin									
ANY	1	0	1	0	0	X	Z	Z	Open
ANY	1	0	1	0	1	L	H	L	CW
ANY	1	0	1	0	1	H	L	L	Short Brake
ANY	1	0	1	1	0	L	L	H	CCW
ANY	1	0	1	1	0	H	L	L	Short Brake
ANY	1	0	1	1	1	X	L	L	Short Brake
CW / CCW Drive Mode via INPUT1 Pin									
ANY	1	1	0	X	0	X	Z	Z	Open
ANY	1	1	0	0	1	L	L	H	CCW
ANY	1	1	0	0	1	H	H	L	CW
ANY	1	1	0	1	1	X	L	L	Short Brake
CW / CCW Drive Mode via INPUT1 Pin									
ANY	1	1	1	X	0	X	Z	Z	Open
ANY	1	1	1	0	1	L	H	L	CW
ANY	1	1	1	0	1	H	L	H	CCW
ANY	1	1	1	1	1	X	L	L	Short Brake

L: Low, H: High, X: Don't care, Z: Hi impedance

(Note 12) CW: Current flows from OUT1A to OUT3A, CCW: Current flows from OUT3A to OUT1A

Table 21. I/O Truth Table (Exclusive Drive Mode for OUT2A-OUT3B)

Serial Interface Bit						INPUT	OUTPUT		
MODE 23	MODE 13	MODE 12B	MODE 12A	IN2B	IN2A	INPUT2	OUT2A	OUT3B	Output Mode (Note 13)
PWM Drive Mode via INPUT2 Pin									
1	ANY	0	0	0	0	X	Z	Z	Open
1	ANY	0	0	0	1	L	L	L	Short Brake
1	ANY	0	0	0	1	H	H	L	CW
1	ANY	0	0	1	0	L	L	L	Short Brake
1	ANY	0	0	1	0	H	L	H	CCW
1	ANY	0	0	1	1	X	L	L	Short Brake
PWM Drive Mode via INPUT2 Pin									
1	ANY	0	1	0	0	X	Z	Z	Open
1	ANY	0	1	0	1	L	H	L	CW
1	ANY	0	1	0	1	H	L	L	Short Brake
1	ANY	0	1	1	0	L	L	H	CCW
1	ANY	0	1	1	0	H	L	L	Short Brake
1	ANY	0	1	1	1	X	L	L	Short Brake
CW / CCW Drive Mode via INPUT2 Pin									
1	ANY	1	0	X	0	X	Z	Z	Open
1	ANY	1	0	0	1	L	L	H	CCW
1	ANY	1	0	0	1	H	H	L	CW
1	ANY	1	0	1	1	X	L	L	Short Brake
CW / CCW Drive Mode via INPUT2 Pin									
1	ANY	1	1	X	0	X	Z	Z	Open
1	ANY	1	1	0	1	L	H	L	CW
1	ANY	1	1	0	1	H	L	H	CCW
1	ANY	1	1	1	1	X	L	L	Short Brake

L: Low, H: High, X: Don't care, Z: Hi impedance

(Note 13) CW: Current flows from OUT2A to OUT3B, CCW: Current flows from OUT3B to OUT2A

Timing chart – continued

Table 22. I/O Truth Table (Channel 4, Driving via INPUT34 pin)

Serial Interface Bit						INPUT	OUTPUT		
MODE 45	MODE 34	MODE 4B	MODE 4A	IN4B	IN4A	INPUT34	OUT4A	OUT4B	Output Mode (Note 14)
PWM Drive Mode via INPUT34 Pin									
0	1	0	0	0	0	X	Z	Z	Open
0	1	0	0	0	1	L	L	L	Short Brake
0	1	0	0	0	1	H	H	L	CW
0	1	0	0	1	0	L	L	L	Short Brake
0	1	0	0	1	0	H	L	H	CCW
0	1	0	0	1	1	X	L	L	Short Brake
PWM Drive Mode via INPUT34 Pin									
0	1	0	1	0	0	X	Z	Z	Open
0	1	0	1	0	1	L	H	L	CW
0	1	0	1	0	1	H	L	L	Short Brake
0	1	0	1	1	0	L	L	H	CCW
0	1	0	1	1	0	H	L	L	Short Brake
0	1	0	1	1	1	X	L	L	Short Brake
CW / CCW Drive Mode via INPUT34 Pin									
0	1	1	0	X	0	X	Z	Z	Open
0	1	1	0	0	1	L	L	H	CCW
0	1	1	0	0	1	H	H	L	CW
0	1	1	0	1	1	X	L	L	Short Brake
CW / CCW Drive Mode via INPUT34 Pin									
0	1	1	1	X	0	X	Z	Z	Open
0	1	1	1	0	1	L	H	L	CW
0	1	1	1	0	1	H	L	H	CCW
0	1	1	1	1	1	X	L	L	Short Brake

L: Low, H: High, X: Don't care, Z: Hi impedance

(Note 14) CW: Current flows from OUT4A to OUT4B, CCW: Current flows from OUT4B to OUT4A

Table 23. I/O Truth Table (Channel 4, Driving via INPUT45 pin)

Serial Interface Bit						INPUT	OUTPUT		
MODE 45	MODE 34	MODE 4B	MODE 4A	IN4B	IN4A	INPUT45	OUT4A	OUT4B	Output Mode (Note 15)
PWM Drive Mode via INPUT45 Pin									
0	0	0	0	0	0	X	Z	Z	Open
0	0	0	0	0	1	L	L	L	Short Brake
0	0	0	0	0	1	H	H	L	CW
0	0	0	0	1	0	L	L	L	Short Brake
0	0	0	0	1	0	H	L	H	CCW
0	0	0	0	1	1	X	L	L	Short Brake
PWM Drive Mode via INPUT45 Pin									
0	0	0	1	0	0	X	Z	Z	Open
0	0	0	1	0	1	L	H	L	CW
0	0	0	1	0	1	H	L	L	Short Brake
0	0	0	1	1	0	L	L	H	CCW
0	0	0	1	1	0	H	L	L	Short Brake
0	0	0	1	1	1	X	L	L	Short Brake
CW / CCW Drive Mode via INPUT45 Pin									
0	0	1	0	X	0	X	Z	Z	Open
0	0	1	0	0	1	L	L	H	CCW
0	0	1	0	0	1	H	H	L	CW
0	0	1	0	1	1	X	L	L	Short Brake
CW / CCW Drive Mode via INPUT45 Pin									
0	0	1	1	X	0	X	Z	Z	Open
0	0	1	1	0	1	L	H	L	CW
0	0	1	1	0	1	H	L	H	CCW
0	0	1	1	1	1	X	L	L	Short Brake

L: Low, H: High, X: Don't care, Z: Hi impedance

(Note 15) CW: Current flows from OUT4A to OUT4B, CCW: Current flows from OUT4B to OUT4A

Timing chart – continued

Table 24. I/O Truth Table (Channel 5)

Serial Interface Bit						INPUT	OUTPUT		
MODE 45	MODE 34	MODE 5B	MODE 5A	IN5B	IN5A	INPUT45	OUT5A	OUT5B	Output Mode (Note 16)
PWM Drive Mode via INPUT45 Pin									
0	1	0	0	0	0	X	Z	Z	Open
0	1	0	0	0	1	L	L	L	Short Brake
0	1	0	0	0	1	H	H	L	CW
0	1	0	0	1	0	L	L	L	Short Brake
0	1	0	0	1	0	H	L	H	CCW
0	1	0	0	1	1	X	L	L	Short Brake
PWM Drive Mode via INPUT45 Pin									
0	1	0	1	0	0	X	Z	Z	Open
0	1	0	1	0	1	L	H	L	CW
0	1	0	1	0	1	H	L	L	Short Brake
0	1	0	1	1	0	L	L	H	CCW
0	1	0	1	1	0	H	L	L	Short Brake
0	1	0	1	1	1	X	L	L	Short Brake
CW / CCW Drive Mode via INPUT45 Pin									
0	1	1	0	X	0	X	Z	Z	Open
0	1	1	0	0	1	L	L	H	CCW
0	1	1	0	0	1	H	H	L	CW
0	1	1	0	1	1	X	L	L	Short Brake
CW / CCW Drive Mode via INPUT45 Pin									
0	1	1	1	X	0	X	Z	Z	Open
0	1	1	1	0	1	L	H	L	CW
0	1	1	1	0	1	H	L	H	CCW
0	1	1	1	1	1	X	L	L	Short Brake

L: Low, H: High, X: Don't care, Z: Hi impedance

(Note 16) CW: Current flows from OUT5A to OUT5B, CCW: Current flows from OUT5B to OUT5A

Table 25. I/O Truth Table (Channel 5)

Serial Interface Bit						INPUT	OUTPUT		
MODE 45	MODE 34	MODE 5B	MODE 5A	IN5B	IN5A	INPUT45	OUT5A	OUT5B	Output Mode (Note 17)
PWM Drive Mode via INPUT45 Pin									
1	0	0	0	0	0	X	Z	Z	Open
1	0	0	0	0	1	L	L	L	Short Brake
1	0	0	0	0	1	H	H	L	CW
1	0	0	0	1	0	L	L	L	Short Brake
1	0	0	0	1	0	H	L	H	CCW
1	0	0	0	1	1	X	L	L	Short Brake
PWM Drive Mode via INPUT45 Pin									
1	0	0	1	0	0	X	Z	Z	Open
1	0	0	1	0	1	L	H	L	CW
1	0	0	1	0	1	H	L	L	Short Brake
1	0	0	1	1	0	L	L	H	CCW
1	0	0	1	1	0	H	L	L	Short Brake
1	0	0	1	1	1	X	L	L	Short Brake
CW / CCW Drive Mode via INPUT45 Pin									
1	0	1	0	X	0	X	Z	Z	Open
1	0	1	0	0	1	L	L	H	CCW
1	0	1	0	0	1	H	H	L	CW
1	0	1	0	1	1	X	L	L	Short Brake
CW / CCW Drive Mode via INPUT45 Pin									
1	0	1	1	X	0	X	Z	Z	Open
1	0	1	1	0	1	L	H	L	CW
1	0	1	1	0	1	H	L	H	CCW
1	0	1	1	1	1	X	L	L	Short Brake

L: Low, H: High, X: Don't care, Z: Hi impedance

(Note 17) CW: Current flows from OUT5A to OUT5B, CCW: Current flows from OUT5B to OUT5A

Timing chart – continued

Table 26. I/O Truth Table for Steeping Motor in Case of 2 Phase Mode

Serial Interface Bit						INPUT		OUTPUT				Output Mode (Note 18)
MODE 12B	MODE 12A	IN2B	IN2A	IN1B	IN1A	INPUT 1	INPUT 2	OUT 1A	OUT 1B	OUT 2A	OUT 2B	
1	0	0	1	0	1	H	H	H	L	H	L	1. CW / CW
1	0	0	1	0	1	H	L	H	L	L	H	2. CCW / CW
1	0	0	1	0	1	L	L	L	H	L	H	3. CCW / CCW
1	0	0	1	0	1	L	H	L	H	H	L	4. CW / CCW

L: Low, H: High, X: Don't care, Z: Hi impedance
 (Note 18) CW: Current flows from OUTxA to OUTxB, CCW: Current flows from OUTxB to OUTxA (x=1, 2)

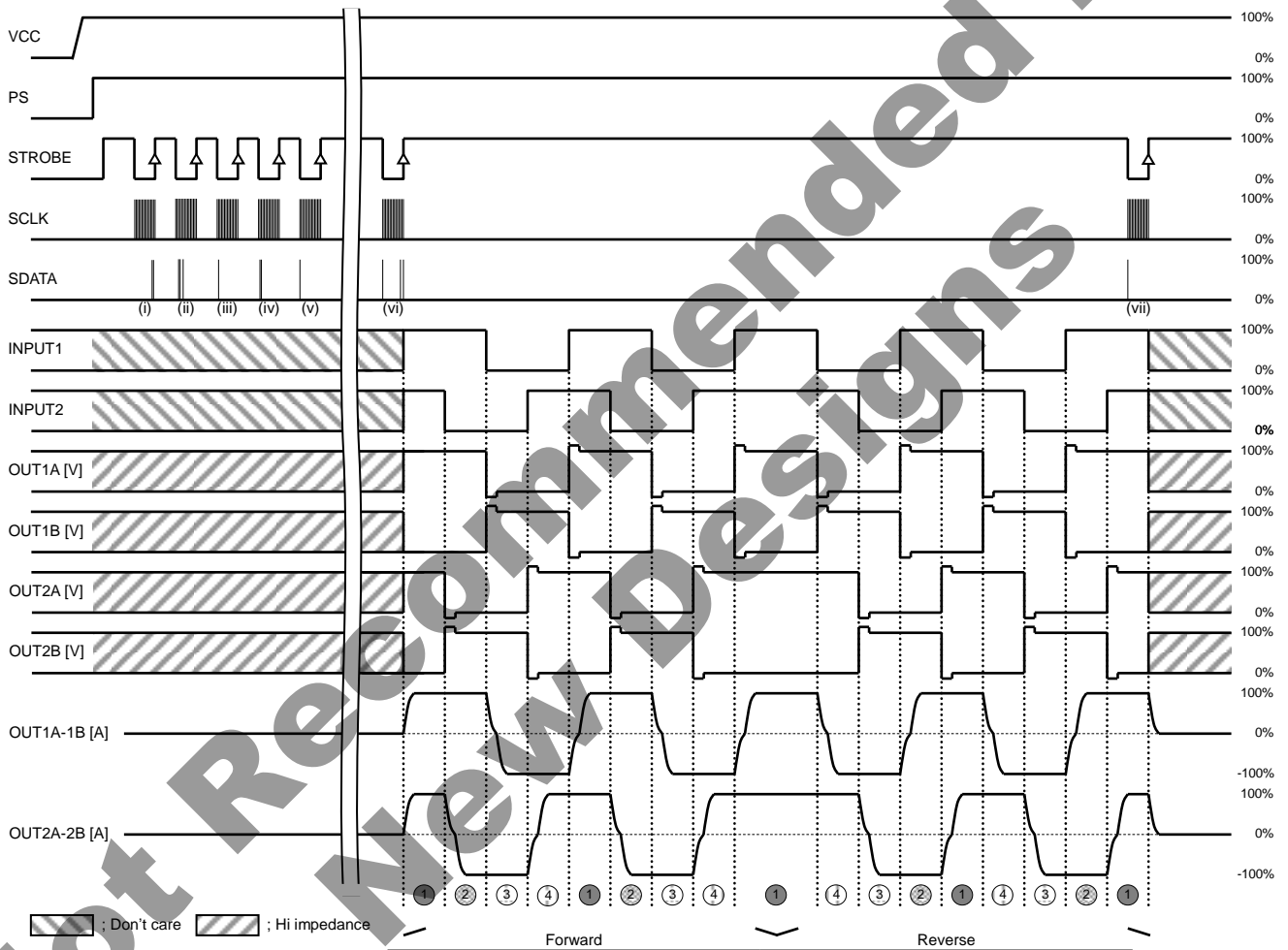

Figure 9.
 Timing Chart of Steeping Motor Drive

Timing chart – continued

Table 27. An Example of Serial Control from Initial Set Up (i) to End Timing (vii) (SDATA image in Figure 9.)

ADR.	DATA BIT											
	Bit[B]	Bit[A]	Bit[9]	Bit[8]	Bit[7]	Bit[6]	Bit[5]	Bit[4]	Bit[3]	Bit[2]	Bit[1]	Bit[0]
Initial set up												
(i) ADDRESS BIT [000]; Setup of channel 1 & channel 2 to drive Constant-Voltage mode												
000			MODE 45	MODE 34	MODE 23	MODE 13	MODE 3C	MODE 3B	MODE 3A	MODE 12C	MODE 12B	MODE 12A
			0	0	0	0	0	0	0	0	1	1
(ii) ADDRESS BIT [001]; Setup of output high voltage=3.0V for channel 1 & channel 2												
001	DAC 12[5]	DAC 12[4]	DAC 12[3]	DAC 12[2]	DAC 12[1]	DAC 12[0]	MODE 5B	MODE 5A	MODE 4D	MODE 4C	MODE 4B	MODE 4A
	1	0	1	0	0	0	0	0	0	0	0	0
(iii) ADDRESS BIT [010]; No need in this case												
010	DAC 5[5]	DAC 5[4]	DAC 5[3]	DAC 5[2]	DAC 5[1]	DAC 5[0]	DAC 3[5]	DAC 3[4]	DAC 3[3]	DAC 3[2]	DAC 3[1]	DAC 3[0]
	0	0	0	0	0	0	0	0	0	0	0	0
(iv) ADDRESS BIT [011]; No need in this case												
011	DAC V4[5]	DAC V4[4]	DAC V4[3]	DAC V4[2]	DAC V4[1]	DAC V4[0]	DAC I4[5]	DAC I4[4]	DAC I4[3]	DAC I4[2]	DAC I4[1]	DAC I4[0]
	0	0	0	0	0	0	0	0	0	0	0	0
(v) ADDRESS BIT [100]; Setup of stand-by mode												
100			IN5B	IN5A	IN4B	IN4A	IN3B	IN3A	IN2B	IN2A	IN1B	IN1A
			0	0	0	0	0	0	0	0	0	0
Start timing												
(vi) ADDRESS BIT [100]												
100			IN5B	IN5A	IN4B	IN4A	IN3B	IN3A	IN2B	IN2A	IN1B	IN1A
			0	0	0	0	0	0	0	1	0	1
End timing												
(vii) ADDRESS BIT [100]												
100			IN5B	IN5A	IN4B	IN4A	IN3B	IN3A	IN2B	IN2A	IN1B	IN1A
			0	0	0	0	0	0	0	0	0	0

Application Example

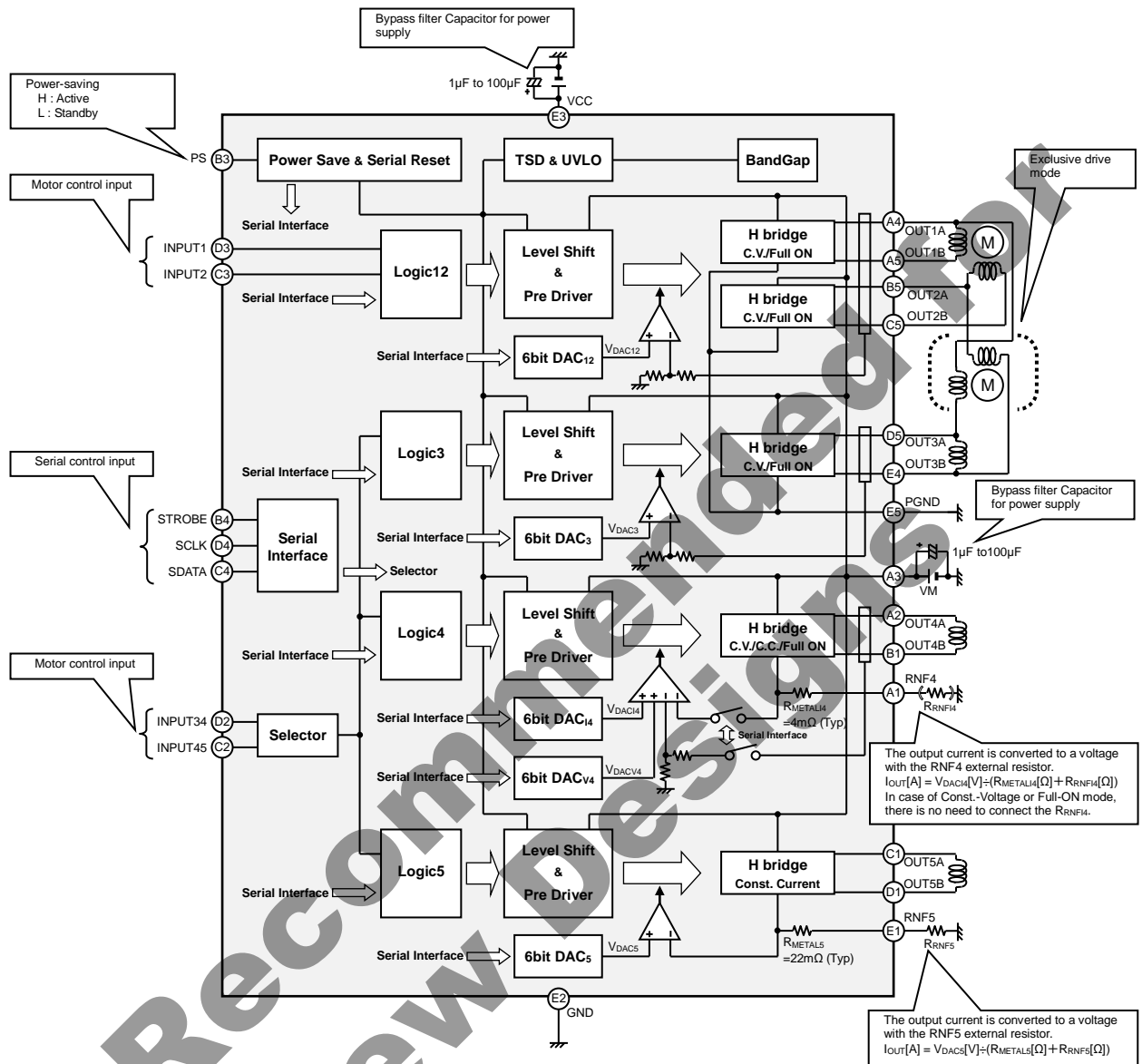

Selection of Components Externally Connected

When using the circuit with changes to the external circuit constants, make sure to leave an adequate margin for external components including static and transitional characteristics as well as dispersion of the IC.

Power Dissipation

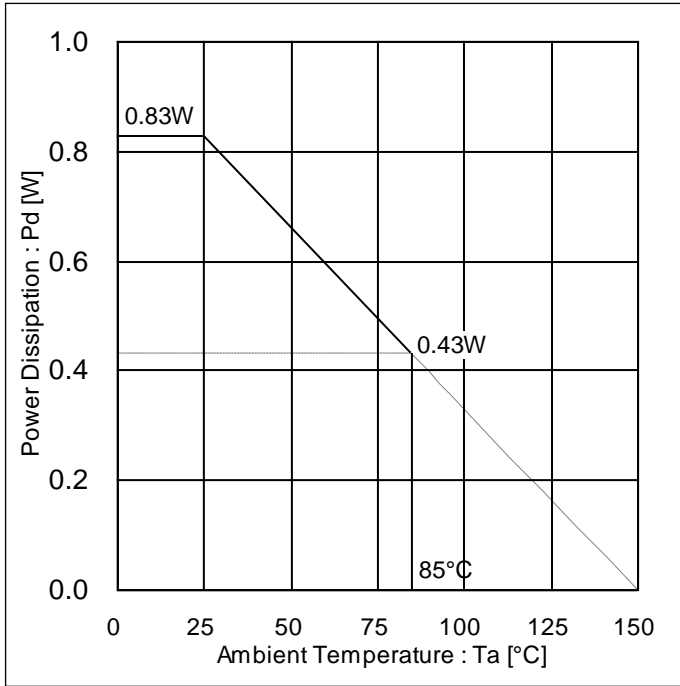
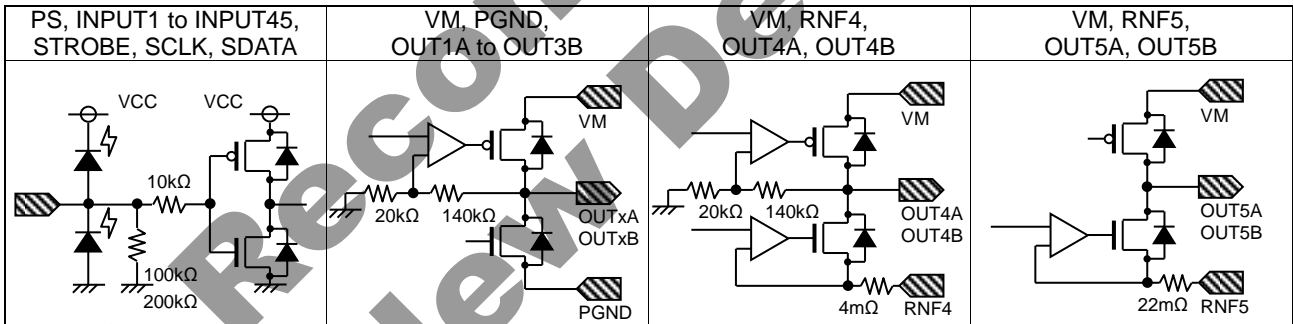

Figure 10.
Power Dissipation vs Ambient Temperature

I/O Equivalent Circuits



Operational Notes

1. Reverse Connection of Power Supply

Connecting the power supply in reverse polarity can damage the IC. Take precautions against reverse polarity when connecting the power supply, such as mounting an external diode between the power supply and the IC's power supply pins.

2. Power Supply Lines

Design the PCB layout pattern to provide low impedance supply lines. Separate the ground and supply lines of the digital and analog blocks to prevent noise in the ground and supply lines of the digital block from affecting the analog block. Furthermore, connect a capacitor to ground at all power supply pins. Consider the effect of temperature and aging on the capacitance value when using electrolytic capacitors.

3. Ground Voltage

Ensure that no pins are at a voltage below that of the ground pin at any time, even during transient condition.

4. Ground Wiring Pattern

When using both small-signal(GND) and large-current ground(PGND) traces, the two ground traces should be routed separately but connected to a single ground at the reference point of the application board to avoid fluctuations in the small-signal ground caused by large currents. Also ensure that the ground traces of external components do not cause variations on the ground voltage. The ground lines must be as short and thick as possible to reduce line impedance.

5. Thermal Consideration

Should by any chance the power dissipation rating be exceeded the rise in temperature of the chip may result in deterioration of the properties of the chip. In case of exceeding this absolute maximum rating, increase the board size and copper area to prevent exceeding the Pd rating.

6. Recommended Operating Conditions

These conditions represent a range within which the expected characteristics of the IC can be approximately obtained. The electrical characteristics are guaranteed under the conditions of each parameter.

7. Inrush Current

When power is first supplied to the IC, it is possible that the internal logic may be unstable and inrush current may flow instantaneously due to the internal powering sequence and delays, especially if the IC has more than one power supply. Therefore, give special consideration to power coupling capacitance, power wiring, width of ground wiring, and routing of connections.

8. Operation Under Strong Electromagnetic Field

Operating the IC in the presence of a strong electromagnetic field may cause the IC to malfunction.

9. Testing on Application Boards

When testing the IC on an application board, connecting a capacitor directly to a low-impedance output pin may subject the IC to stress. Always discharge capacitors completely after each process or step. The IC's power supply should always be turned off completely before connecting or removing it from the test setup during the inspection process. To prevent damage from static discharge, ground the IC during assembly and use similar precautions during transport and storage.

10. Inter-pin Short and Mounting Errors

Ensure that the direction and position are correct when mounting the IC on the PCB. Incorrect mounting may result in damaging the IC. Avoid nearby pins being shorted to each other especially to ground, power supply and output pin. Inter-pin shorts could be due to many reasons such as metal particles, water droplets (in very humid environment) and unintentional solder bridge deposited in between pins during assembly to name a few.

11. Unused Input Pins

Input pins of an IC are often connected to the gate of a MOS transistor. The gate has extremely high impedance and extremely low capacitance. If left unconnected, the electric field from the outside can easily charge it. The small charge acquired in this way is enough to produce a significant effect on the conduction through the transistor and cause unexpected operation of the IC. So unless otherwise specified, unused input pins should be connected to the power supply or ground line.

Operational Notes – continued

12. Regarding the Input Pin of the IC

This monolithic IC contains P+ isolation and P substrate layers between adjacent elements in order to keep them isolated. P-N junctions are formed at the intersection of the P layers with the N layers of other elements, creating a parasitic diode or transistor. For example (refer to figure below):

When $GND > Pin A$ and $GND > Pin B$, the P-N junction operates as a parasitic diode.

When $GND > Pin B$, the P-N junction operates as a parasitic transistor.

Parasitic diodes inevitably occur in the structure of the IC. The operation of parasitic diodes can result in mutual interference among circuits, operational faults, or physical damage. Therefore, conditions that cause these diodes to operate, such as applying a voltage lower than the GND voltage to an input pin (and thus to the P substrate) should be avoided.

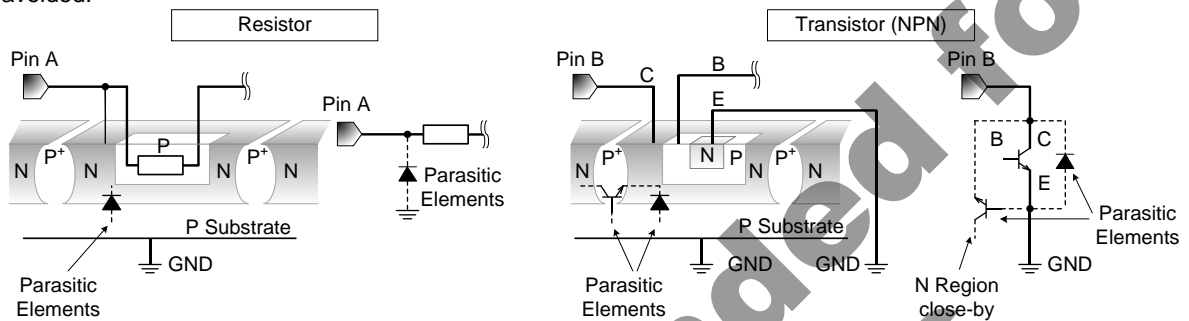

Figure 11.
Example of monolithic IC structure

13. Ceramic Capacitor

When using a ceramic capacitor, determine the dielectric constant considering the change of capacitance with temperature and the decrease in nominal capacitance due to DC bias and others.

14. Area of Safe Operation (ASO)

Operate the IC such that the output voltage, output current, and power dissipation are all within the Area of Safe Operation (ASO).

15. Thermal Shutdown Circuit(TSD)

This IC has a built-in thermal shutdown circuit that prevents heat damage to the IC. Normal operation should always be within the IC's power dissipation rating. If however the rating is exceeded for a continued period, the junction temperature (T_j) will rise which will activate the TSD circuit that will turn OFF all output pins. When the T_j falls below the TSD threshold, the circuits are automatically restored to normal operation.

Note that the TSD circuit operates in a situation that exceeds the absolute maximum ratings and therefore, under no circumstances, should the TSD circuit be used in a set design or for any purpose other than protecting the IC from heat damage.

16. Disturbance light

In a device where a portion of silicon is exposed to light such as in a WL-CSP, IC characteristics may be affected due to photoelectric effect. For this reason, it is recommended to come up with countermeasures that will prevent the chip from being exposed to light.

Ordering Information

B D 6 3 7 0 G U L	-	E 2
Part Number	Package GUL : VCSP50L2	Packaging and forming specification E2: Embossed tape and reel

Marking Diagram

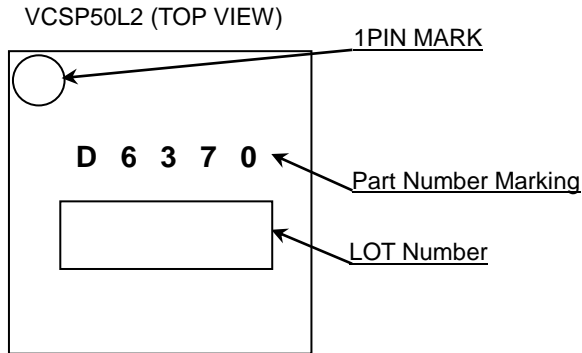

Part Number Marking	Package	Orderable Part Number
D6370	VCSP50L2	BD6370GUL-E2

Not Recommended for New Designs

Physical Dimension, Tape and Reel Information

Package Name	VCSP50L2
--------------	----------

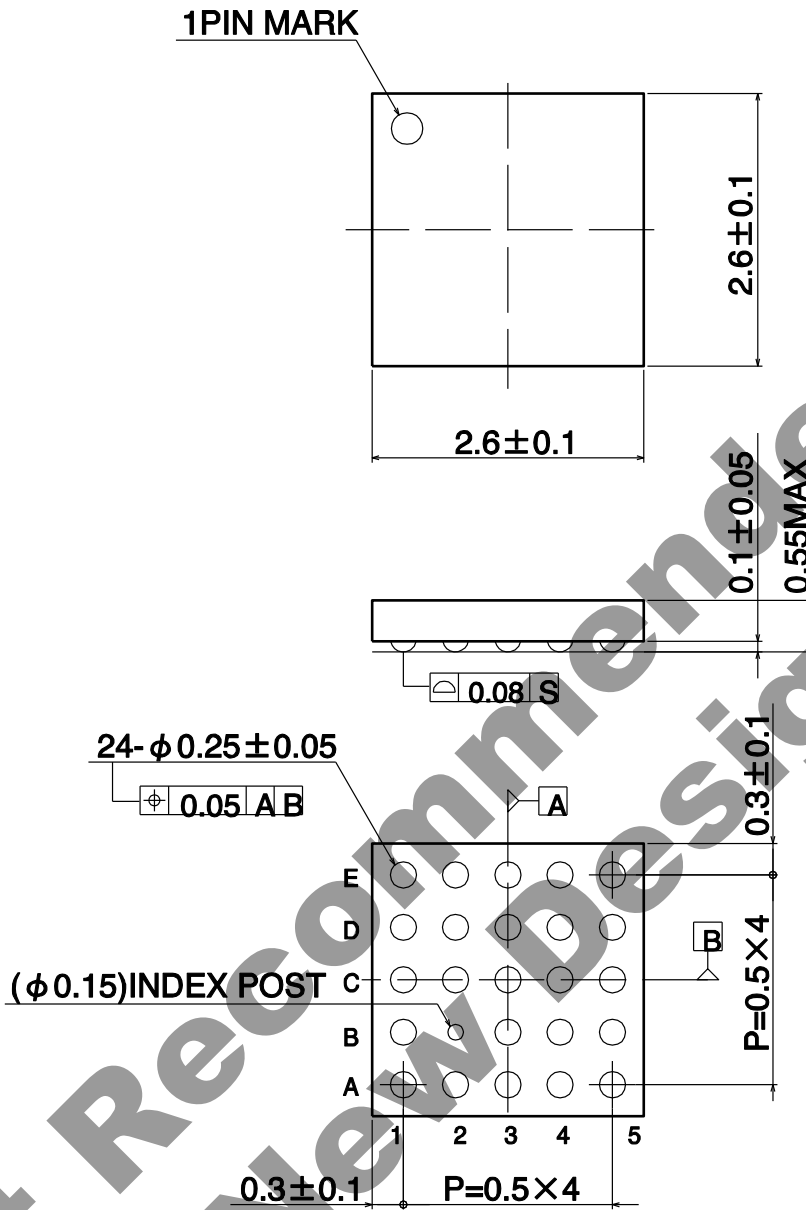

<Tape and Reel information>

Tape	Embossed carrier tape
Quantity	3000pcs
Direction of feed	E2 (The direction is the 1pin of product is at the upper left when you hold reel on the left hand and you pull out the tape on the right hand)

* Order quantity needs to be multiple of the minimum quantity.

Revision History

Date	Revision	Changes
09.Dec.2015	001	New Release

**Not Recommended for
New Designs**

Notice

Precaution on using ROHM Products

- Our Products are designed and manufactured for application in ordinary electronic equipments (such as AV equipment, OA equipment, telecommunication equipment, home electronic appliances, amusement equipment, etc.). If you intend to use our Products in devices requiring extremely high reliability (such as medical equipment ^(Note 1), transport equipment, traffic equipment, aircraft/spacecraft, nuclear power controllers, fuel controllers, car equipment including car accessories, safety devices, etc.) and whose malfunction or failure may cause loss of human life, bodily injury or serious damage to property ("Specific Applications"), please consult with the ROHM sales representative in advance. Unless otherwise agreed in writing by ROHM in advance, ROHM shall not be in any way responsible or liable for any damages, expenses or losses incurred by you or third parties arising from the use of any ROHM's Products for Specific Applications.

(Note1) Medical Equipment Classification of the Specific Applications

JAPAN	USA	EU	CHINA
CLASS III	CLASS III	CLASS II b	CLASS III
CLASS IV		CLASS III	

- ROHM designs and manufactures its Products subject to strict quality control system. However, semiconductor products can fail or malfunction at a certain rate. Please be sure to implement, at your own responsibilities, adequate safety measures including but not limited to fail-safe design against the physical injury, damage to any property, which a failure or malfunction of our Products may cause. The following are examples of safety measures:
 - Installation of protection circuits or other protective devices to improve system safety
 - Installation of redundant circuits to reduce the impact of single or multiple circuit failure
- Our Products are designed and manufactured for use under standard conditions and not under any special or extraordinary environments or conditions, as exemplified below. Accordingly, ROHM shall not be in any way responsible or liable for any damages, expenses or losses arising from the use of any ROHM's Products under any special or extraordinary environments or conditions. If you intend to use our Products under any special or extraordinary environments or conditions (as exemplified below), your independent verification and confirmation of product performance, reliability, etc. prior to use, must be necessary:
 - Use of our Products in any types of liquid, including water, oils, chemicals, and organic solvents
 - Use of our Products outdoors or in places where the Products are exposed to direct sunlight or dust
 - Use of our Products in places where the Products are exposed to sea wind or corrosive gases, including Cl₂, H₂S, NH₃, SO₂, and NO₂
 - Use of our Products in places where the Products are exposed to static electricity or electromagnetic waves
 - Use of our Products in proximity to heat-producing components, plastic cords, or other flammable items
 - Sealing or coating our Products with resin or other coating materials
 - Use of our Products without cleaning residue of flux (even if you use no-clean type fluxes, cleaning residue of flux is recommended); or Washing our Products by using water or water-soluble cleaning agents for cleaning residue after soldering
 - Use of the Products in places subject to dew condensation
- The Products are not subject to radiation-proof design.
- Please verify and confirm characteristics of the final or mounted products in using the Products.
- In particular, if a transient load (a large amount of load applied in a short period of time, such as pulse. is applied, confirmation of performance characteristics after on-board mounting is strongly recommended. Avoid applying power exceeding normal rated power; exceeding the power rating under steady-state loading condition may negatively affect product performance and reliability.
- De-rate Power Dissipation depending on ambient temperature. When used in sealed area, confirm that it is the use in the range that does not exceed the maximum junction temperature.
- Confirm that operation temperature is within the specified range described in the product specification.
- ROHM shall not be in any way responsible or liable for failure induced under deviant condition from what is defined in this document.

Precaution for Mounting / Circuit board design

- When a highly active halogenous (chlorine, bromine, etc.) flux is used, the residue of flux may negatively affect product performance and reliability.
- In principle, the reflow soldering method must be used on a surface-mount products, the flow soldering method must be used on a through hole mount products. If the flow soldering method is preferred on a surface-mount products, please consult with the ROHM representative in advance.

For details, please refer to ROHM Mounting specification

Precautions Regarding Application Examples and External Circuits

1. If change is made to the constant of an external circuit, please allow a sufficient margin considering variations of the characteristics of the Products and external components, including transient characteristics, as well as static characteristics.
2. You agree that application notes, reference designs, and associated data and information contained in this document are presented only as guidance for Products use. Therefore, in case you use such information, you are solely responsible for it and you must exercise your own independent verification and judgment in the use of such information contained in this document. ROHM shall not be in any way responsible or liable for any damages, expenses or losses incurred by you or third parties arising from the use of such information.

Precaution for Electrostatic

This Product is electrostatic sensitive product, which may be damaged due to electrostatic discharge. Please take proper caution in your manufacturing process and storage so that voltage exceeding the Products maximum rating will not be applied to Products. Please take special care under dry condition (e.g. Grounding of human body / equipment / solder iron, isolation from charged objects, setting of ionizer, friction prevention and temperature / humidity control).

Precaution for Storage / Transportation

1. Product performance and soldered connections may deteriorate if the Products are stored in the places where:
 - [a] the Products are exposed to sea winds or corrosive gases, including Cl₂, H₂S, NH₃, SO₂, and NO₂
 - [b] the temperature or humidity exceeds those recommended by ROHM
 - [c] the Products are exposed to direct sunshine or condensation
 - [d] the Products are exposed to high Electrostatic
2. Even under ROHM recommended storage condition, solderability of products out of recommended storage time period may be degraded. It is strongly recommended to confirm solderability before using Products of which storage time is exceeding the recommended storage time period.
3. Store / transport cartons in the correct direction, which is indicated on a carton with a symbol. Otherwise bent leads may occur due to excessive stress applied when dropping of a carton.
4. Use Products within the specified time after opening a humidity barrier bag. Baking is required before using Products of which storage time is exceeding the recommended storage time period.

Precaution for Product Label

QR code printed on ROHM Products label is for ROHM's internal use only.

Precaution for Disposition

When disposing Products please dispose them properly using an authorized industry waste company.

Precaution for Foreign Exchange and Foreign Trade act

Since concerned goods might be fallen under listed items of export control prescribed by Foreign exchange and Foreign trade act, please consult with ROHM in case of export.

Precaution Regarding Intellectual Property Rights

1. All information and data including but not limited to application example contained in this document is for reference only. ROHM does not warrant that foregoing information or data will not infringe any intellectual property rights or any other rights of any third party regarding such information or data.
2. ROHM shall not have any obligations where the claims, actions or demands arising from the combination of the Products with other articles such as components, circuits, systems or external equipment (including software).
3. No license, expressly or implied, is granted hereby under any intellectual property rights or other rights of ROHM or any third parties with respect to the Products or the information contained in this document. Provided, however, that ROHM will not assert its intellectual property rights or other rights against you or your customers to the extent necessary to manufacture or sell products containing the Products, subject to the terms and conditions herein.

Other Precaution

1. This document may not be reprinted or reproduced, in whole or in part, without prior written consent of ROHM.
2. The Products may not be disassembled, converted, modified, reproduced or otherwise changed without prior written consent of ROHM.
3. In no event shall you use in any way whatsoever the Products and the related technical information contained in the Products or this document for any military purposes, including but not limited to, the development of mass-destruction weapons.
4. The proper names of companies or products described in this document are trademarks or registered trademarks of ROHM, its affiliated companies or third parties.



General Precaution

1. Before you use our Products, you are requested to carefully read this document and fully understand its contents. ROHM shall not be in any way responsible or liable for failure, malfunction or accident arising from the use of any ROHM's Products against warning, caution or note contained in this document.
2. All information contained in this document is current as of the issuing date and subject to change without any prior notice. Before purchasing or using ROHM's Products, please confirm the latest information with a ROHM sales representative.
3. The information contained in this document is provided on an "as is" basis and ROHM does not warrant that all information contained in this document is accurate and/or error-free. ROHM shall not be in any way responsible or liable for any damages, expenses or losses incurred by you or third parties resulting from inaccuracy or errors of or concerning such information.





**Not Recommended for
New Designs**

Looking for pricing, stock, or lifecycle information?

Click below to explore more details on WIN SOURCE:

-  [View BD6370GUL-E2 on WIN SOURCE](#)
-  [Rohm Semiconductor](#) Information

Optimize Your Supply Chain with WIN SOURCE Solutions

-  Global Sourcing Solution
-  Obsolete Management
-  Cost Control Management
-  Shortage Management
-  Alternative Solution
-  Excess Inventory Management