

LED Drivers for LCD Backlights

White Backlight LED Driver for Medium to Large LCD Panels (Switching Regulator Type)



BD6150MUV

No.11040EBT06

●Description

BD6150MUV is white LED driver IC with PWM step-up DC/DC converter that can boost max 40V and current driver that can drive max 30mA. The wide and precision brightness can be controlled by external PWM pulse. BD6150MUV has very accurate current drivers, and it has few current errors between each strings. So, it will be helpful to reduce brightness spots on the LCD. Small package type is suited for saving space.

●Features

- 1) High efficiency PWM step-up DC/DC converter (fsw=1.25MHz / 0.75MHz)
- 2) High accuracy & good matching current drivers (MAX30mA/ch)
- 3) Integrated 50V power Nch MOSFET
- 4) Soft start
- 5) Drive up to 10 in series 6strings in parallel
- 6) Wide input voltage range (4.2V ~ 26V)
- 7) Rich safety functions
 - Over-voltage protection
 - LED terminal open/short protect
 - UVLO
 - Over current limit
 - External SBD open detect / Output short protection
 - Thermal shutdown
- 8) Small & thin package (VQFN024V4040) 4.0 × 4.0 × 1.0mm

●Applications

All middle size LCD equipments backlight of Notebook PC, portable DVD player, car navigation systems, etc.

●Absolute maximum ratings (Ta=25°C)

Parameter	Symbol	Ratings	Unit	Condition
Maximum applied voltage 1	VMAX1	7	V	VREG, ISET, PWMDRV, FSEL, OCPSET, VDET, TEST
Maximum applied voltage 2	VMAX2	25	V	LED1, LED2, LED3, LED4, LED5, LED6
Maximum applied voltage 3	VMAX3	30.5	V	VBAT, FAILFLAG, PWMPOW
Maximum applied voltage 4	VMAX4	41	V	SW
Power dissipation 1	Pd1	500 ^{*1}	mW	
Power dissipation 2	Pd2	780 ^{*2}	mW	
Power dissipation 3	Pd3	1510 ^{*3}	mW	
Operating temperature range	Topr	-40 ~ +85	°C	
Storage temperature range	Tstg	-55 ~ +150	°C	

*1 Reduced 4.0mW/°C With Ta>25°C when not mounted on a heat radiation Board.

*2 1 layer (ROHM Standard board) has been mounted. Copper foil area 0mm², When it's used by more than Ta=25°C, it's reduced by 6.2mW/°C.

*3 4 layer (JEDEC Compliant board) has been mounted. Copper foil area 1layer 6.28mm², Copper foil area 2~4layers 5655.04mm², When it's used by more than Ta=25°C, it's reduced by 12.1mW/°C.

● Recommended operating range (Ta=-40°C ~ +85°C)

Parameter	Symbol	Limits			Unit	Condition
		Min.	Typ.	Max.		
Power supply voltage	VBAT	4.2	12.0	26.0	V	

● Electrical characteristic (Unless otherwise specified, VBAT=12V, Ta = +25°C)

Parameter	Symbol	Limits			Unit	Condition
		Min.	Typ.	Max.		
Quiescent current	Iq	-	1.6	4.4	μA	PWMPow=0V
Current consumption	Idd	-	3.2	4.8	mA	VDET=0V, ISET=22kΩ
[PWMPow Terminal]						
Low input voltage range1	POWL	0	-	0.9	V	
High input voltage range1	POWH	2.1	-	VBAT	V	
Pull down resistor1	POWR	100	300	500	kΩ	PWMPow=3V
[PWMDRV Terminal]						
Low input voltage range2	PDRVL	0	-	0.9	V	
High input voltage range2	PDRVH	2.1	-	5.5	V	
Pull down resistor2	DRVR	100	300	500	kΩ	
[FSEL Terminal]						
Low input voltage range3	FSL	0	-	0.9	V	
High input voltage range3	FSH	2.1	-	6.0	V	
Pull down resistor3	FSR	100	300	500	kΩ	FSEL=1V
[FAILFLAG]						
Input resistor	FFIR	1.0	2.0	3.0	kΩ	FAILFLAG=2.5V
Off current	FFIST	-	0.1	2.0	μA	PWMPow=0V
[Regulator]						
VREG voltage	VREG	4.2	5.0	6.0	V	No load
Under voltage lock out	UVLO	3.3	3.7	4.1	V	VBAT falling edge
[Switching Regulator]						
LED control voltage	VLED	0.56	0.70	0.84	V	
Switching frequency	fsw	1.00	1.25	1.50	MHz	FSEL=L (GND short)
Duty cycle limit	Duty	91	95.0	99.0	%	LED1-6=0.3V
SW Nch FET RON	RON	-	0.48	0.58	Ω	ISW=80mA
[Protection]						
Over current limit	Ocp	1.4	2.0	2.6	A	*1 OCPSET=68kΩ
OCPSET open protect	OOP	-	0.0	0.1	A	OCPSET=2MΩ
Over voltage limit Input	Ovl	0.96	1.00	1.04	V	Detect voltage of VDET pin
SBD open protect	Sop	0.02	0.05	0.08	V	Detect voltage of VDET pin
VDET leak current	OVIL	-	0.1	1.0	μA	
[Current driver]						
LED maximum current	ILMAX	-	-	30	mA	
LED current accuracy	ILACCU	-	-	±3.0	%	ILED=16~20mA
LED current matching	ILMAT	-	-	±1.5	%	Each LED current/Average (LED1-6) ILED=16~20mA
LED current limiter	ILOCP	-	0	0.1	mA	Current limit value at ISET resistor 1kΩ setting
LED terminal Over voltage protect	LEDOVP	10.0	11.5	13.0	V	PWMDRV=2.5V
ISET voltage	Iset	0.5	0.6	0.7	V	

*1 This parameter is tested with DC measurement.

●Reference Data

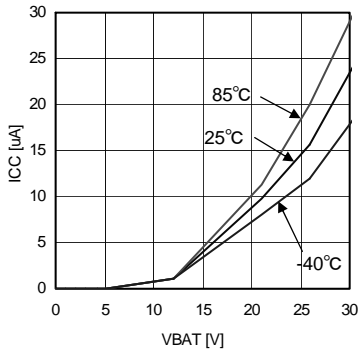

Fig 1. Quiescent Current

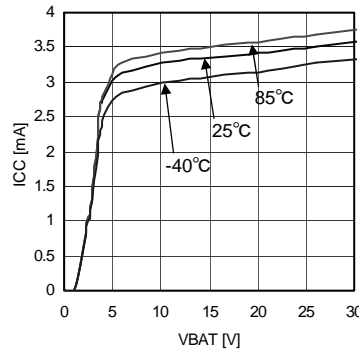

Fig 2. Current Consumption

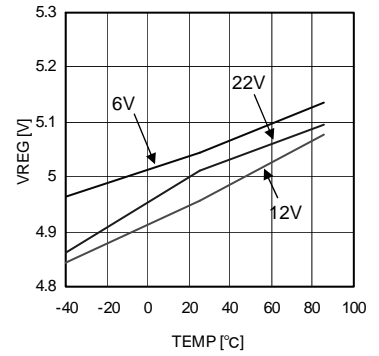

Fig 3. VREG Voltage

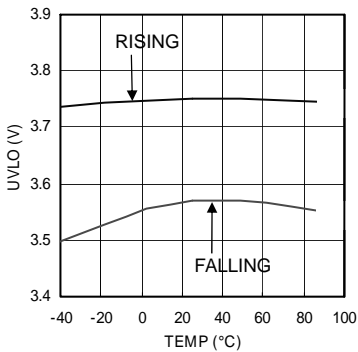

Fig 4. Under Voltage Lock Out

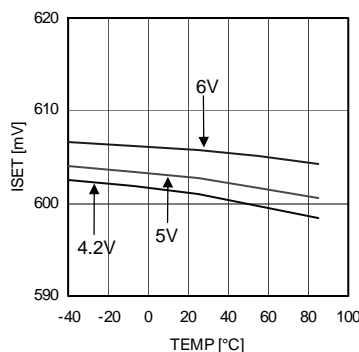

Fig 5. ISET Voltage

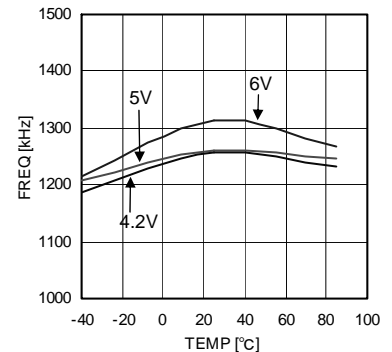

Fig 6. Switching Frequency

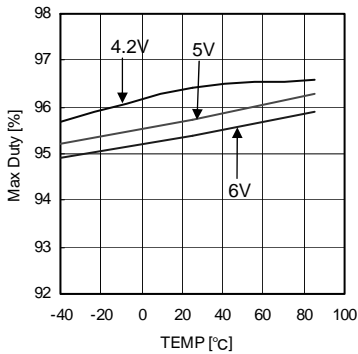

Fig 7. Max Duty

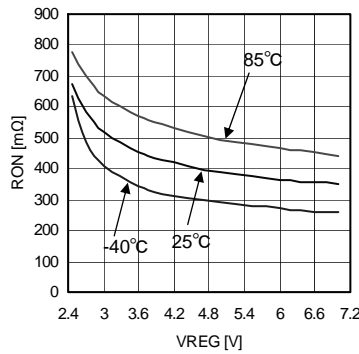

Fig 8. LX Nch RON

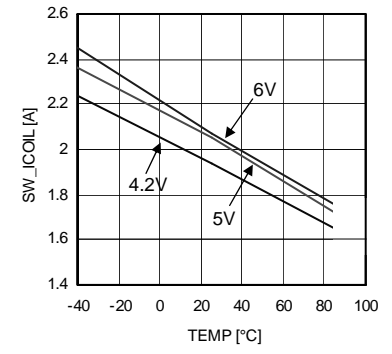

Fig 9. Over Current Limit

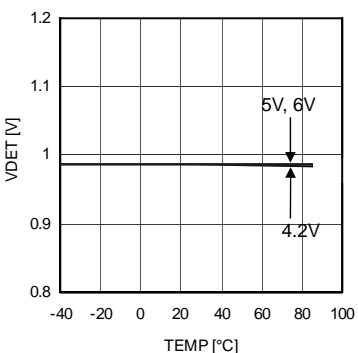

Fig 10. Over Voltage Protect

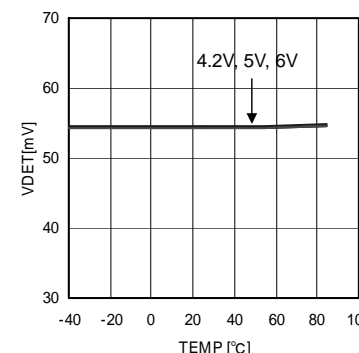

Fig 11. SBD Open Protect

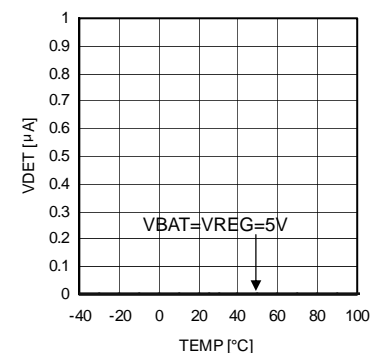

Fig 12. VDET Leak Current

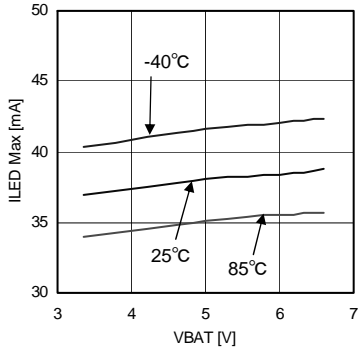

Fig 13. LED Max Current

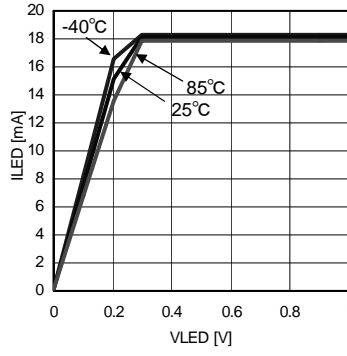

Fig 14. LED Current vs LED Voltage

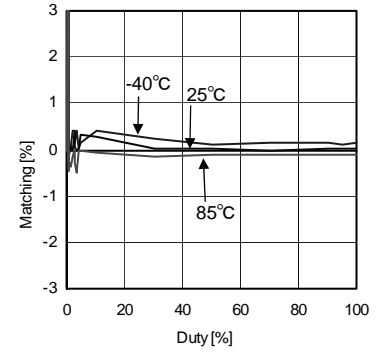

Fig 15. LED Current Matching

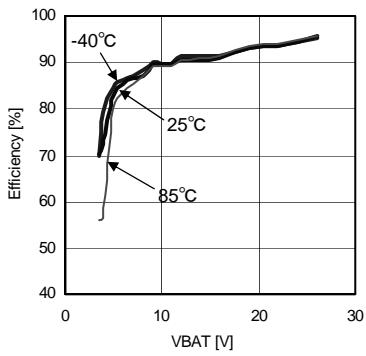

Fig 16. Efficiency
10LEDx6CH

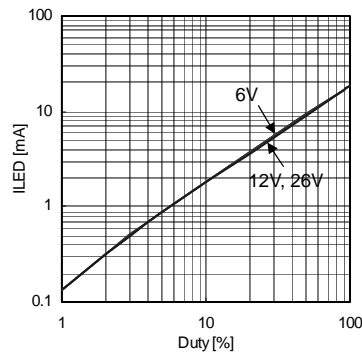

Fig 17. LED Current vs PWM Duty
PWM Freq=200Hz LED 10x6CH

●Block diagram

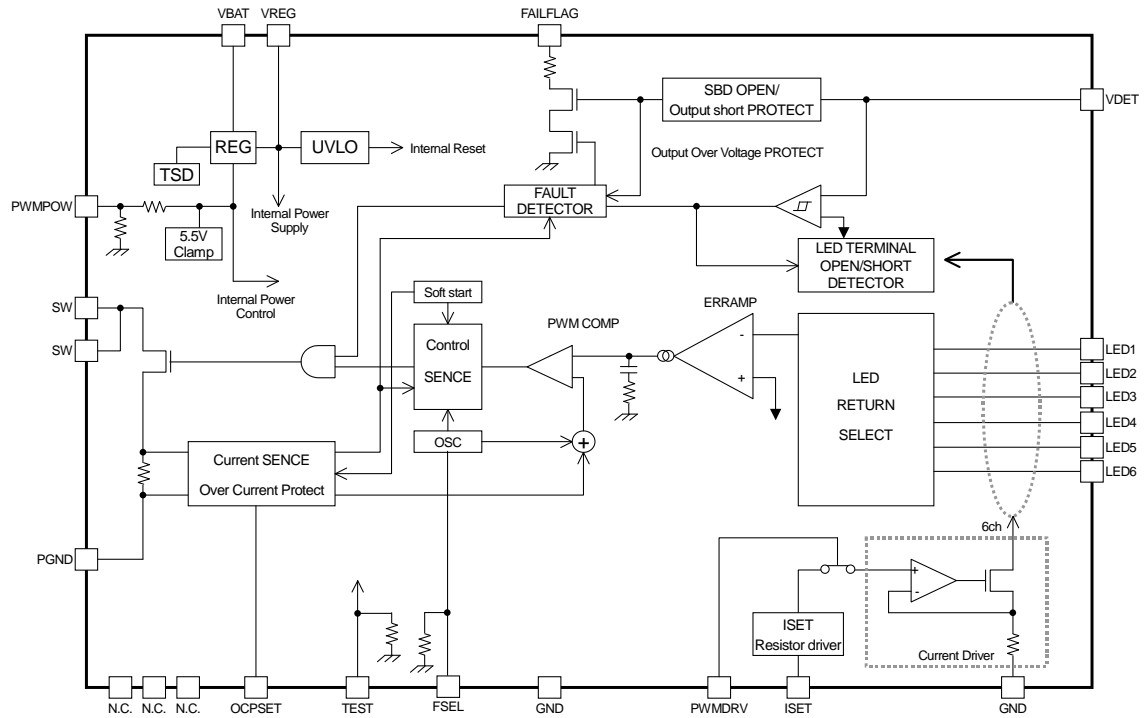

Fig.18 BD6150MUV block diagram

●Application example

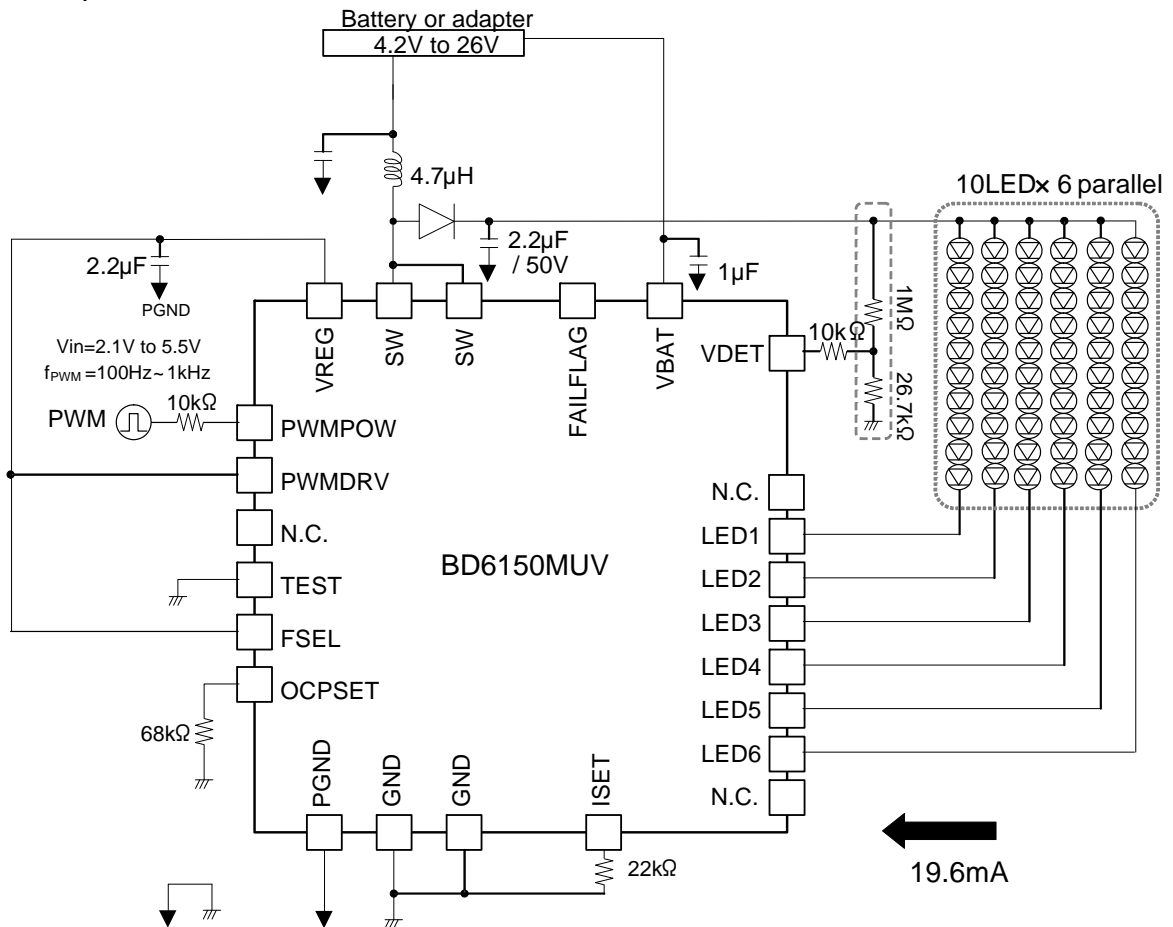
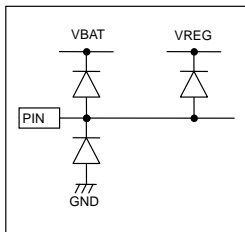

Fig.19 Application example (10LED x 6parallel, Switching frequency 750kHz)

● Pin assignment table

PIN No.	PIN Name	In/Out	Function	Terminal diagram
1	SW	Out	Switching Tr drive terminal	H
2	SW	Out	Switching Tr drive terminal	H
3	N.C.	-	No connect pin	F
4	PGND	-	PGND for switching Tr	D
5	FAILFLAG	Out	Fail Flag	C
6	OCPSET	In	Current Limiter setting	A
7	VDET	In	Detect input for SBD open and OVP	A
8	TEST	In	TEST signal	J
9	FSEL	In	Selection of Frequency, 'L': 1.25MHz, 'H': 0.75MHz	J
10	ISET	In	Resister connection for LED current setting	A
11	GND	-	GND for Switching Regulator	B
12	N.C.	In	No connect pin	F
13	LED1	In	Current sink for LED	C
14	LED2	In	Current sink for LED	C
15	LED3	In	Current sink for LED	C
16	LED4	In	Current sink for LED	C
17	LED5	In	Current sink for LED	C
18	LED6	In	Current sink for LED	C
19	N.C.	In	No connect pin	F
20	GND	-	GND for Current driver	B
21	PWMDRV	In	PWM input pin for power ON/OFF only driver	G
22	VREG	Out	Regulator output / Internal power-supply	D
23	PWMPow	In	PWM input pin for power ON/OFF	E
24	VBAT	In	Battery input	I



A

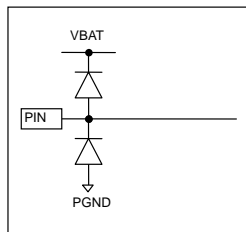

B

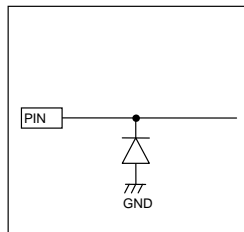

C

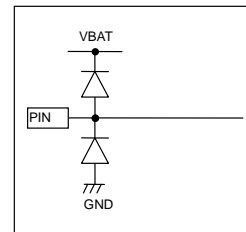

D

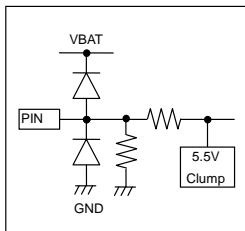

E

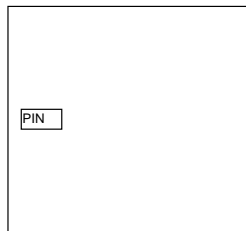

F

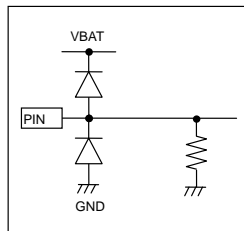

G

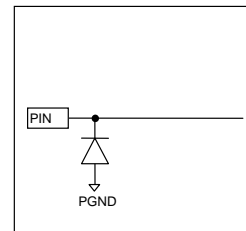

H

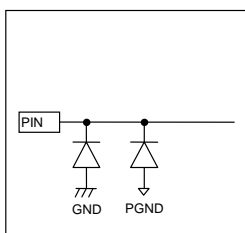

I

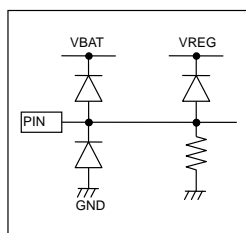

J

●Description of Functions

1) PWM current mode DC/DC converter

While this IC is power ON, the lowest voltage of LED terms is detected, PWM duty is decided to be 0.7V and output voltage is kept invariably. As for the inputs of the PWM comparator as the feature of the PWM current mode, one is overlapped with error components from the error amplifier, and the other is overlapped with a current sense signal that controls the inductor current into Slope waveform to prevent sub harmonic oscillation. This output controls internal Nch Tr via the RS latch. In the period where internal Nch Tr gate is ON, energy is accumulated in the external inductor, and in the period where internal Nch Tr gate is OFF, energy is transferred to the output capacitor via external SBD. This IC has many safety functions, and their detection signals stop switching operation at once.

2) Soft start

This IC has soft start function.

The soft start function prevents large coil current.

Rush current at turning on is prevented by the soft start function.

After PWMPOW, PWMDRV is changed L→ H, soft start becomes effective for within 4ms and soft start doesn't become effective even if PWMPOW is changed L→ H after that.

And, when the H section of PWMPOW is within 4ms, soft start becomes invalid when PWMPOW is input to H more than three times. The invalid of the soft start can be canceled by making PWMPOW, PWMDRV → L.

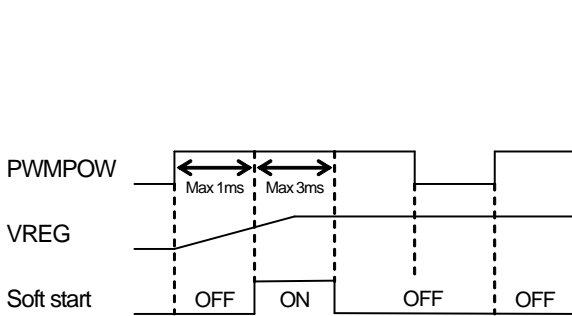

Fig.20 Soft start

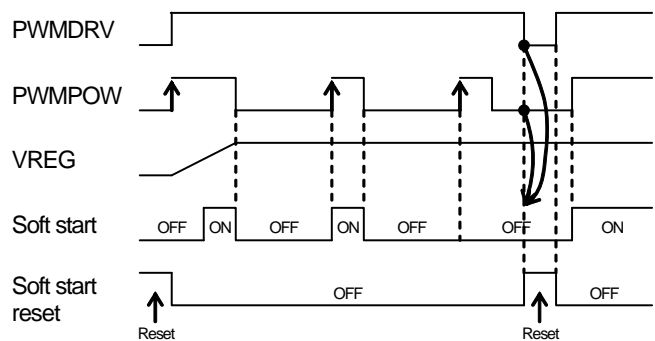

Fig.21 Soft start reset and set

3) FAILFLAG

When the error condition occurs, boost operating is stopped by the protection function, and the error condition is outputted from FAILFLAG. After power ON, when the protection function is operating under about 1ms have passed.

Object of protect function is as shown below.

- Over-voltage protection
- External SBD open detect/ Output Short protection
- LED terminal open/short protection
- Over current limit

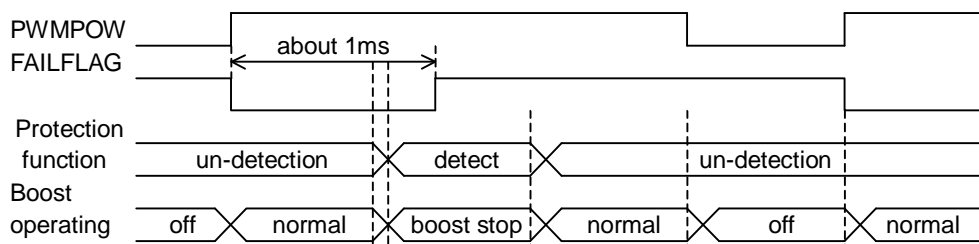

Fig.22 FAILFLAG operating description

●Protection

• Over voltage protection

At such an error of output open as the output DC/DC and the LED is not connected to IC, the DC/DC will boost too much and the VDET terminal exceed the absolute maximum ratings, and may destruct the IC. Therefore, when VDET becomes sensing voltage or higher, the over voltage limit works, and turns off the output Tr, and the pressure up made stop.

At this moment, the IC changes from activation into non-activation, and the output voltage goes down slowly. And, when the Feedback of LED1 isn't returned, so that Vout will return normal voltage.

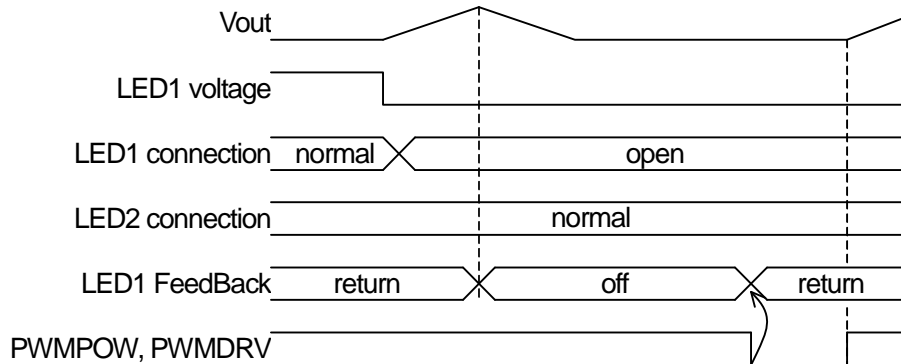

Fig.23 VDET operating description

• External SBD open detect / Output short protection

In the case of external SBD is not connected to IC, or VOUT is shorted to GND, the coil or internal Tr may be destructed. Therefore, at such an error as VDET becoming 0.05V or below, and turns off the output Tr, and prevents the coil and the IC from being destructed.

And the IC changes from activation into non-activation, and current does not flow to the coil (0mA).

• Thermal shut down

This IC has thermal shut down function.

The thermal shut down works at 175°C or higher, and the IC changes from activation into non-activation.

●How to set over voltage limit

This section is especially mentioned here because the spec shown electrical characteristic is necessary to explain this section.

Over voltage limit	min 0.96V	typ 1.00V	max 1.04V
LED control voltage	min 0.56V	typ 0.70V	max 0.84V
LED terminal over voltage protect	min 10.0V	typ 11.5 V	max 13.0V

- Calculate the conditions that the total value of LED VF is MAX.
Example) In the case of serial 8 LEDs with VF=2.9V(min), 3.2V(typ), 3.5V(max) => 3.5V x 8=28V
- Then calculate the biggest value of output with the following formula.
The biggest value of output = the biggest value calculated for 1 + the biggest value of LED terminal voltage. (0.84V)
Example) The biggest value of output = 28V + 0.84V =28.84V
- Set the smallest value of over voltage larger than the biggest value of output.
If over voltage is closer to the total value of VF, it could be occurred to detect over voltage by ripple, noise, and so on. It is recommended that some margins should be left on the difference between over voltage and the total value of VF. This time around 6% margin is placed.
Example) Against the biggest value of output = 28.84V, the smallest value of over voltage = 28.84V x 1.06 = 30.57V
Ic over voltage limit min=0.96V,typ=1.00V, max=1.04V
typ = 30.57V x (1.00V/0.96V) = 31.8V
max = 31.8V x (1.04V/1.00V) = 33.1V
- The below shows how to control resistor setting over voltage
Please fix resistor 2.2MΩ between VDET and output and then set over voltage after changing resistor between VDET and GND. While PWM is off, output voltage decreases by minimizing this resistor. Due to the decrease of output voltage, ripple of output voltage increases, and singing of output condenser also becomes bigger.
Example) Selecting OVP resistor.
(Example 1) VF=3.6V max, serial = 7 LED
OVP = 1.0V, R1 = 2.2MΩ, R2 = 78.7kΩ
VOUT = 1.0 x (2.2MΩ + 78.7kΩ)/ 78.7kΩ = 28.95V
(Example 2) VF=3.6V max, serial = 8 LED
OVP = 1.0V, R1 = 2.2MΩ, R2 = 69.8kΩ
VOUT = 1.0 x (2.2MΩ + 69.8kΩ)/ 69.8kΩ = 32.52
(Example 3) VF=3.6V max, serial = 9 LED
OVP = 1.0V, R1 = 2.2MΩ, R2 = 62kΩ
VOUT = 1.0 x (2.2MΩ + 62kΩ)/ 62kΩ = 36.48V
(Example 4) VF=3.6V max, serial = 10 LED
OVP = 1.0V, R1 = 1.0MΩ, R2 = 26.7kΩ
VOUT = 1.0 x (1.0MΩ + 26.7kΩ)/ 26.7kΩ = 38.45V
- The following shows how to confirm if LEDs are not turned on while selecting terminals. If the difference between the VF's total value of LED and over voltage is less than min.10V of LED terminal over voltage protect, LEDs should be turned on.

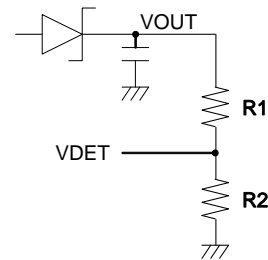

LEDs are turned on, as the following formula shows; 33.1V-2.9V x 8 serial = 9.9V<10.0V.

Over Current Limit

Over current flows the current detection resistor that is connected to internal switching transistor source and between PGND, Current sense voltage turns more than detection voltage decided with OCPSET, over current protection is operating and it is prevented from flowing more than detection current by reducing ON duty of switching Tr without stopping boost.

As over current detector of This IC is detected peak current, current more than over current setting value does not flow. And, over current value can decide freely by changing OCPSET voltage.

The range of over current setting is from 0.5A to 2.5A.

<Derivation sequence of detection resistor>

$$R(\text{OCPSET}) = 34\text{k}\Omega \times \text{Over current setting}$$

TYP value of over current is 2A, MIN = 1.4A and MAX = 2.6A and after the current value which was necessary for the normal operation was decided, detection resistor is derived by using MIN value of over current detection value.

For example, detection resistor when typ value was set at 2A is given as shown below.

$$\text{Detection resistor} = 34\text{k}\Omega \times 2\text{A} = 68\text{k}\Omega$$

MAX current dispersion of this detection resistor value is

$$\text{MAX current} = 2\text{A} \times 1.3 = 2.6\text{A}$$

For example, 34kΩ → 1A, 68kΩ → 2A

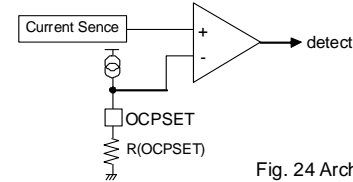

Fig. 24 Architecture

<The estimate of the current value which need for the normal operation >

As over current detector of This IC is detected the peak current, it have to estimate peak current to flow to the coil by operating condition.

- | | |
|----------------------------------|---|
| ○ Supply voltage of coil = VIN | ○ Inductance value of coil = L |
| ○ Switching frequency = fsw | MIN=1.0MHz, Typ=1.25MHz, MAX=1.5MHz |
| ○ Output voltage = VOUT | ○ Total LED current = IOUT |
| ○ Average current of coil = Iave | ○ Peak current of coil = Ipeak |
| ○ Efficiency = eff | ○ ON time of switching transistor = Ton |

$$I_{\text{peak}} = (V_{\text{IN}} / L) \times (1 / f_{\text{sw}}) \times (1 - (V_{\text{IN}} / V_{\text{OUT}}))$$

$$I_{\text{ave}} = (V_{\text{OUT}} \times I_{\text{OUT}} / V_{\text{IN}}) / \text{eff}$$

$$T_{\text{on}} = (I_{\text{ave}} \times (1 - V_{\text{IN}} / V_{\text{OUT}}) \times (1 / f_{\text{sw}}) \times (L / V_{\text{IN}}) \times 2)^{1/2}$$

Each current is calculated.

As peak current varies according to whether there is the direct current superposed, the next is decided.

$$(1 - V_{\text{IN}} / V_{\text{OUT}}) \times (1 / f_{\text{sw}}) < T_{\text{on}} \rightarrow \text{peak current} = I_{\text{peak}} / 2 + I_{\text{ave}}$$

$$(1 - V_{\text{IN}} / V_{\text{OUT}}) \times (1 / f_{\text{sw}}) > T_{\text{on}} \rightarrow \text{peak current} = (V_{\text{IN}} / L) \times T_{\text{on}}$$

(Example 1)

In case of, VIN=6.0V, L=4.7μH, fsw=1.25MHz, VOUT=39V, IOUT=80mA, Efficiency=85%

$$I_{\text{peak}} = (6.0\text{V} / 4.7\mu\text{H}) \times (1 / 1.25\text{MHz}) \times (1 - (6.0\text{V} / 39\text{V})) = 0.86\text{A}$$

$$I_{\text{ave}} = (39\text{V} \times 80\text{mA} / 6.0\text{V}) / 85\% = 0.61\text{A}$$

$$T_{\text{on}} = (0.61\text{A} \times (1 - 6.0\text{V} / 39\text{V}) \times (1 / 1.25\text{MHz}) \times (4.7\mu\text{H} / 6.0\text{V}) \times 2)^{1/2} = 0.81\mu\text{s}$$

$$(1 - V_{\text{IN}} / V_{\text{OUT}}) \times (1 / f_{\text{sw}}) = 0.68\mu\text{s} < T_{\text{on}}$$

$$\text{Peak current} = 0.68\text{A} / 2 + 0.61\text{A} = 1.04\text{A}$$

(Example 2)

In case of, VIN=12.0V, L=4.7μH, fsw=1.25MHz, VOUT=39V, IOUT=80mA, Efficiency=85%

$$I_{\text{peak}} = (12.0\text{V} / 4.7\mu\text{H}) \times (1 / 1.25\text{MHz}) \times (1 - (12\text{V} / 39\text{V})) = 1.41\text{A}$$

$$I_{\text{ave}} = (39\text{V} \times 80\text{mA} / 12.0\text{V}) / 85\% = 0.31\text{A}$$

$$T_{\text{on}} = (0.31\text{A} \times (1 - 12\text{V} / 39\text{V}) \times (1 / 1.25\text{MHz}) \times (4.7\mu\text{H} / 12\text{V}) \times 2)^{1/2} = 0.36\mu\text{s}$$

$$(1 - V_{\text{IN}} / V_{\text{OUT}}) \times (1 / f_{\text{sw}}) = 0.55\mu\text{s} > T_{\text{on}}$$

$$\text{Peak current} = 12\text{V} / 4.7\mu\text{H} \times 0.36\mu\text{s} = 0.92\text{A}$$

* When too large current is set, output overshoot is caused, be careful enough because it is led to break down of the IC in case of the worst.

- soft start of Over current limit for application

When the capacitor of OCPSET is set as figure, over current limit can become setting value slowly.
This effect is same as internal soft start.

When you want to reduce peak current than internal soft start on start up, this way is effective.

But, this action repeat when the timing that PWMPOW change L to H, so to do PWM control with PWMPOW terminal, rise time of over current limit must be set into Hi time of PWM control, and please don't connect the capacitor.

Show example of rising wave form with OCPSET 330pF.

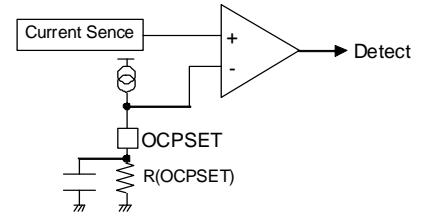
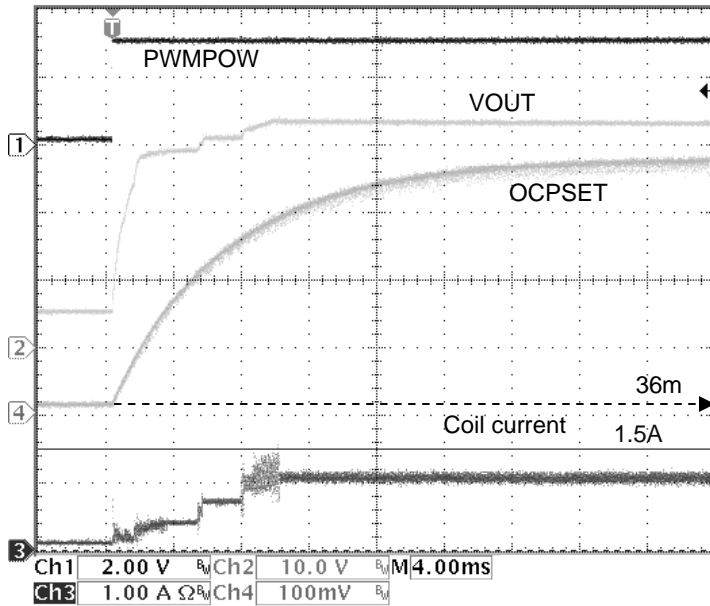

Fig.25 Rising wave form with VBAT=5V, 6parallel 10serial 20mA/ch, OCPSET=68kΩ,330pF

●Operating of the application deficiency

- 1) When 1 LED or 1string OPEN during the operating
 The LED string that became OPEN isn't lighting, but other LED strings are lighting.
 Then LED terminal is 0V, output boosts up to the over voltage protection voltage. When over voltage is detected, the feedback of open string isn't returned, so that VOUT will return normal voltage.
 In the case that the voltage of 2 LED terminals becomes more than 25V(Absolute maximum ratings) as VOUT boosts up to the over voltage protection voltage, please pay attention carefully that 2 LED terminals could be broken up in setting over voltage protection.

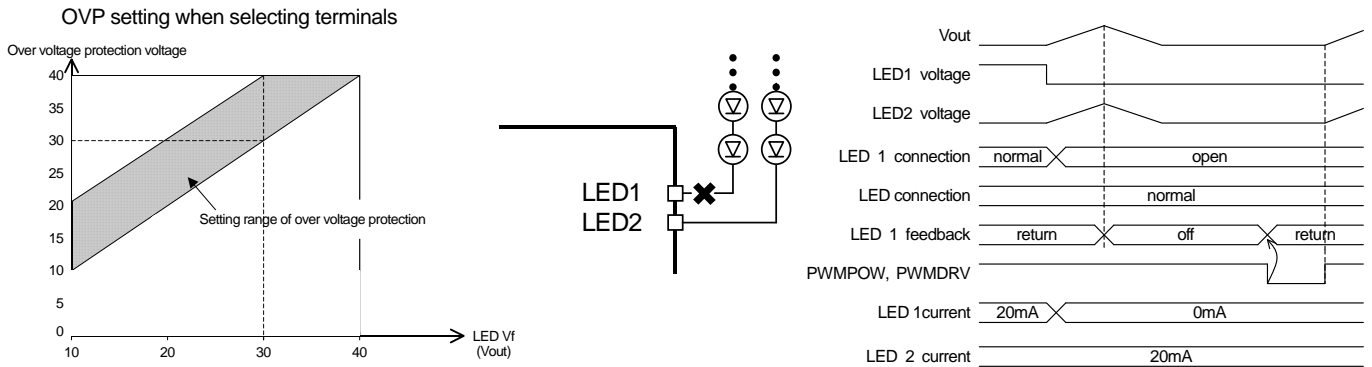

Fig.26 LED OPEN detect

Moreover, excessively high level of over voltage limit in terminal setting makes it happen that LED terminal voltage exceeds LED terminal over voltage protect, which accordingly turn off LED lights. In order to prevent this problem, please see "How to set the external resistor of over voltage limit (p.7)" and then set over voltage referring to application.

- 2) When LED short-circuited in the plural
 All LED strings is turned on unless LED1~6 terminal voltage is more than 11.5V.
 When it was more than 11.5V only the strings which short-circuited is turned off normally and LED current of other lines continue to turn on.

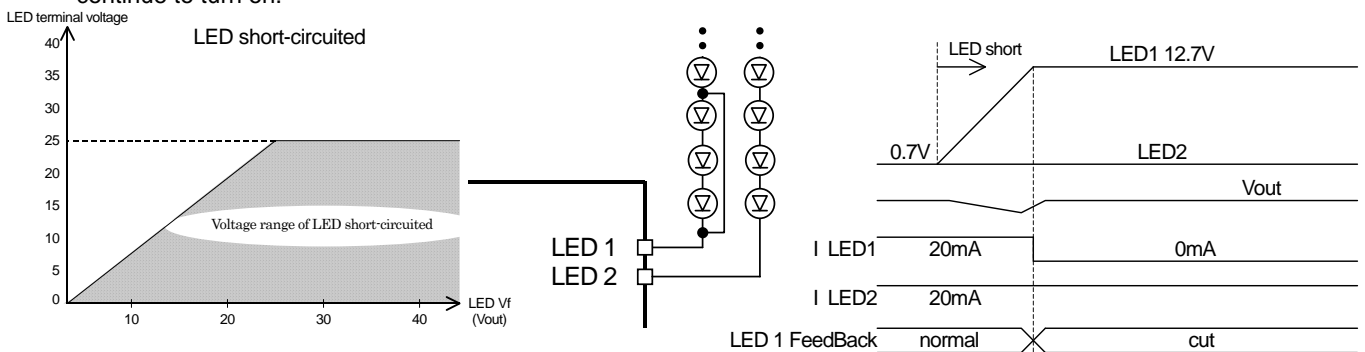

Fig.27 LED short detect

- 3) When Schottky diode comes off
 IC and a switching transistor aren't destroyed because boost operating stops by the Schottky diode coming off protected function.
- 4) When the resistor of over current detection comes off
 All the LEDs do not turn on due to open protect of the OVP resistor, which stops boost operation and consequently prevents passing LED current.

●How to activate

Please pay attention to the following when activating.

1. The lights are turned off by LED terminal over voltage protection in the case that LED terminal voltage is more than 11.5V(typ) at PWMDRV=H. LED terminal becomes more than 11.5V depending on OVP setting. In that case, please refer to how to set on P7.
2. In the case that capacitors are placed between anode and casode, LED terminal might become more than 11.5V depending on power supply activating time. Please make t12 in Fig.28 long enough until LED terminal becomes less than 11.5V. or use application.
3. If PWMPOW and PWMDRV terminal voltage become more than VBAT voltage in the case that activation of power supply voltage (VBAT) is not completely finished, error might be occurred by supplying power supply into VBAT via ESD protection diode on the VBAT side of each terminal.

Fig.28 shows input timing of VBAT, PWMPOW, and PWMDRV. Please input signal paying attention to the above. In the case that conditions are not good enough, it happens that lights are turned off at activation.

Terminal select circuit inside IC operates using VREG as power supply. In the case that VREG does not activate (less than UVLO), please set PWMDRV=H t12 hours after setting PWMPOW=H. Terminal select circuit is reset by PWMDRV=L signal while VREG rises after PWMPOW=L->H. Lights might be turned off unless PWMDRV=L is input until VREG becomes stable at activation. After activation, VREG voltage is more than UVLO, reset is not needed since terminal information is saved.

At light dimming of PWMDRV terminal

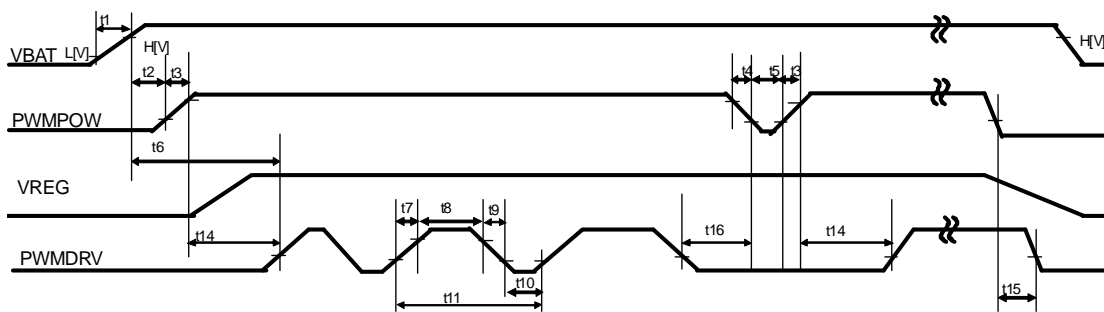

At light dimming of PWMPOW terminal

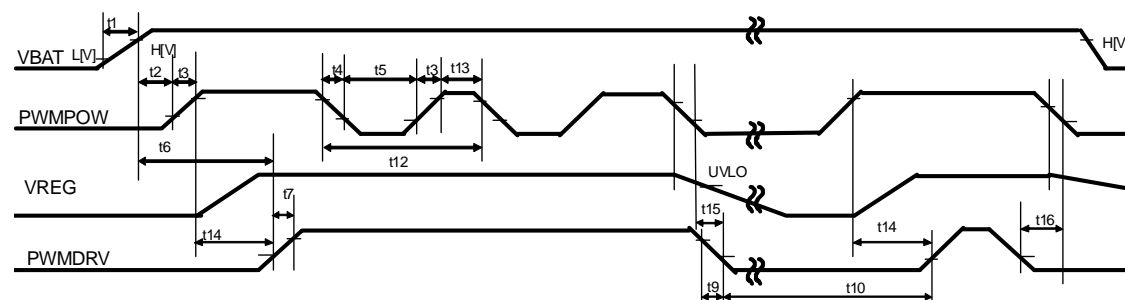

Fig.28 input timing

	Name	Unit	Min.	Typ.	Max.
t1	Power supply activating time	μs	100	-	-
t2	Power supply-PWMPOW time	μs	0	-	-
t3	PWMPOW rising time	μs	0	-	100
t4	PWMPOW falling time	μs	0	-	100
t5	PWMPOW low time	μs	50	-	-
t6	Power supply-PWMDRV time	μs	1600	-	-
t7	PWMDRV rising time	μs	0	-	100
t8	PWMDRV high time	μs	5	-	-
t9	PWMDRV falling time	μs	0	-	100
t10	PWMDRV low time	μs	5	-	-
t11	PWMDRV cycle	μs	40	5000	10000
t12	PWMPOW cycle	μs	1000	5000	10000
t13	PWMPOW high time	μs	50	-	-
t14	PWMPOW(H)->PWMDRV(H) time	μs	1500	-	-
t15	PWMPOW(L)->PWMDRV(L) time	μs	0	-	-
t16	PWMDRV(L)->PWMPOW(L) time	μs	0	-	-
H	Operation Voltage	V	4.2	12	26
L	Non operation voltage	V	-	-	4.2

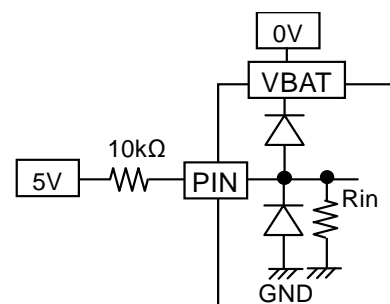

Fig.29 Example of application at control signal voltage > VBAT voltage

●Start control (PWMPow) and select LED current driver (PWMDRV)

This IC can control the IC system by PWMPow, and IC can power off compulsory by setting 0.9V or below. Also, It powers on PWMPow is at more than 2.1V.

After it's selected to PWMPow=H, When it is selected at PWMDRV=H, LED current decided with ISET resistance flow. Next, When it is selected at PWMDRV=L, LED current stop to flow.

PWMPow	PWMDRV	IC	LED current
L	L	Off	OFF
H	L	On	OFF
L	H	Off	OFF
H	H	On	Current decided with ISET

●How to select the number of LED lines of the current driver

When the number of LED lines of the current driver is reduced, the un-select can be available by setting the unnecessary LED1~6 terminals OPEN. In the case of using 4 lines and so on, please connect the unnecessary 2 lines OPEN.

Then please set PWMPow and PWMDRV "H" and finish selecting the lines within the process of softstart. If the level of over voltage limit is set too high, the connected LED lines exceed LED terminal over voltage protect and are judged as unnecessary lines.

Please make it sure referring "How to set over voltage limit (p.7)".

Additionally, once the terminals are judged as unnecessary, this information never can be reset without setting PWMPow and PWMDRV "L".

●LED current setting range

LED current can set up Normal current by resistance value (RISET) connecting to ISET voltage.

Setting of each LED current is given as shown below.

$$\text{Normal current} = 16\text{mA} (27\text{k}\Omega / \text{RISET})$$

Also, Normal current setting range is 10mA~30mA. LED current becomes a leak current MAX 2 μ A at OFF setting.

When using beyond current setting range, please be careful that the error in LED current setting could be large.

ISET Normal current setting example

RISET	LED current
18k Ω (E24)	24.0mA
22k Ω (E24)	19.6mA
24k Ω (E24)	18.0mA
27k Ω (E24)	16.0mA
30k Ω (E24)	14.4mA
33k Ω (E24)	13.1mA

●Brightness control

There are two dimming method is available, first method is analog dimming that apply analog voltage to ISET terminal, and second method is PWM control via digital dimming of PWMPow or PWMDRV. Because each method has the different merit, please choose a suitable method for the application of use.

Two techniques can be used as digital dimming by the PWM control One is PWM control of current driver, the other is PWM control of power control.

As these two characteristics are shown in the below, selects to PWM control process comply with application.

- Efficiency emphasis in the low brightness which has an influence with the battery life → 2) Power control PWM control
- LED current dispersion emphasis in the PWM brightness control → 1) Current driver PWM control

(Reference)

PWM regulation process	Efficiency of LED current 0.5mA (PWM Duty=2.5%)	PWM frequency 200Hz Limit dispersion capability of low duty
Current driver	74.8%	0.04%
Power control	91%	0.40%

- 1) Current driver PWM control is controlled by providing PWM signal to PWMDRV, as it is shown Fig.30. The current set up with ISET is chosen as the H section of PWMDRV and the current is off as the L section. Therefore, the average LED current is increasing in proportion to duty cycle of PWMDRV signal. This method that it lets internal circuit and DC/DC to work, because it becomes to switch the driver, the current tolerance is a few when the PWM brightness is adjusted, so it makes it possible to brightness control until $5\mu\text{s}$ (MIN0.1% at 200Hz). And, don't use for the brightness control, because effect of ISET changeover is big under $1\mu\text{s}$ ON time and under $1\mu\text{s}$ OFF time. Typical PWM frequency is 100Hz~25kHz.

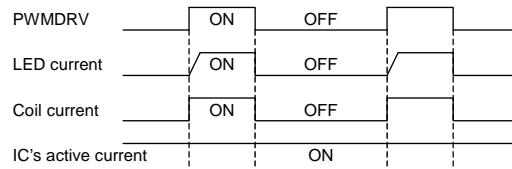

Fig.30 PWMDRV sequence

- 2) Power control PWM control is controlled by providing PWM signal to PWMPOW, as it is shown Fig.31. The current setting set up with PWMDRV logic is chosen as the H section and the current is off as the L section. Therefore, the average LED current is increasing in proportion to duty cycle of PWMPOW signal. This method is, because IC can be power-off at off-time, the consumption current can be suppress, and the high efficiency can be available, so it makes it possible to brightness control until $50\mu\text{s}$ (MIN1% at 200Hz). And, don't use for the brightness control, because effect of power ON/OFF time changeover is big under $50\mu\text{s}$ ON time and under $50\mu\text{s}$ OFF time. Typical PWM frequency is 100Hz~1kHz.

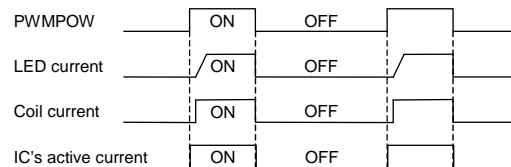

Fig.31 PWMPOW sequence

●Output voltage ripple for PWM dimming

Conditio : 8serial 6parallel, LED current=20mA/ch, VBAT=7V, Ta=25°C, output capacitor=2.2μF(50V/B3)

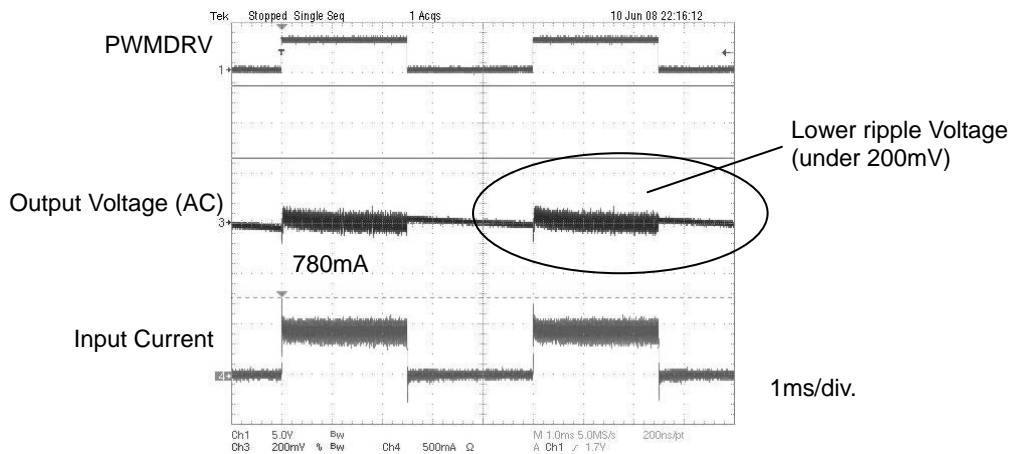

Fig.32 Output voltage ripple for PWM dimming

●LED current rise and fall for PWM dimming

Conditions : 8serial 6parallel, LED current=20mA/ch, VBAT=7V, Ta=25°C, output capacitor=2.2μF(50V/B3)

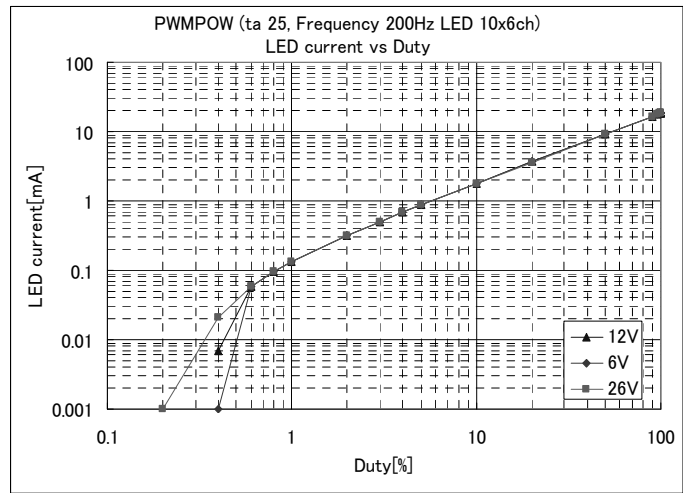
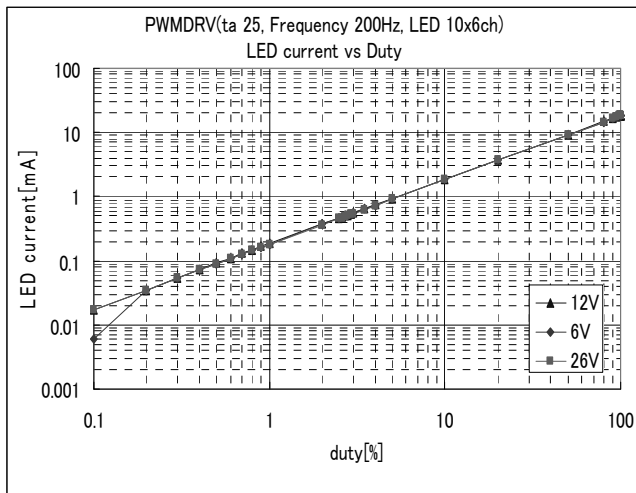
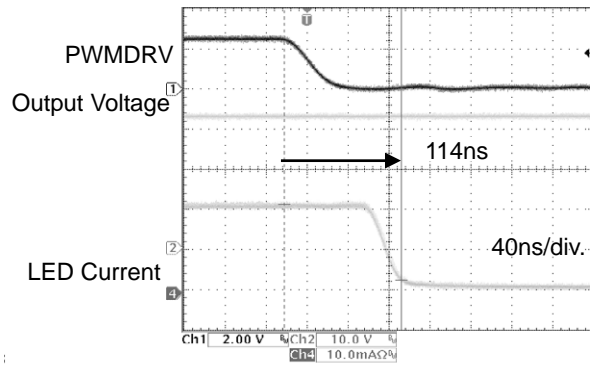
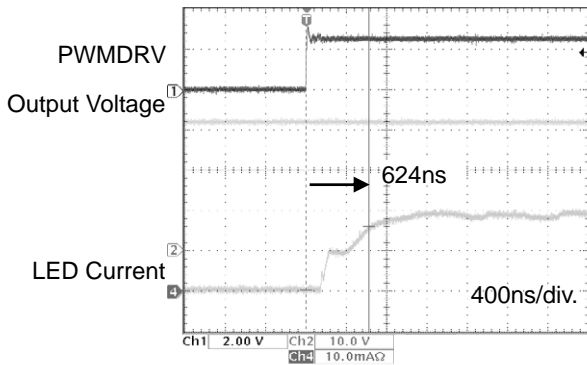

Fig.33 PWM characteristics of current driver PWM

Fig.34 PWM characteristics of power control PWM

●Main characteristics of efficiency

Conditions : 10serial 6parallel, LED current=20mA/ch, output capacitor=2.2μF(50V/B3)

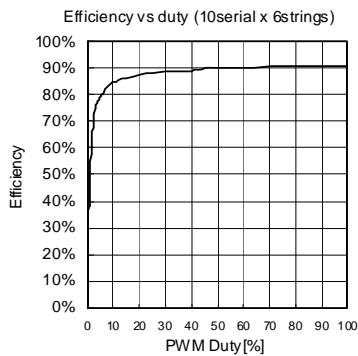
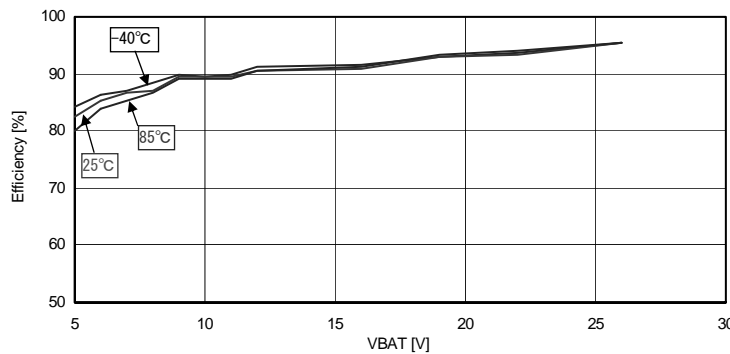

Fig.35 Efficiency of current driver PWM

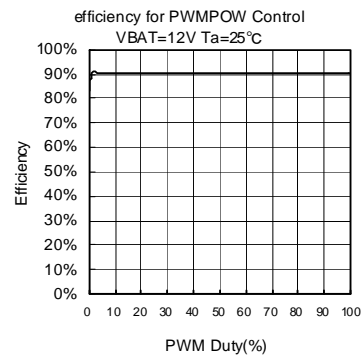

Fig.36 Efficiency of power control PWM

●The coil selection

The DC/DC is designed by more than 4.7μH. When L value sets to a lower value, it is possibility that the specific sub-harmonic oscillation of current mode DC / DC will be happened. Please do not let L value to 3.3μH or below. And, L value increases, the phase margin of DC / DC becomes to zero. Please enlarge the output capacitor value when you increase L value.

Example)

4.7μH	=	output capacitor	2.2μF/50V	1pcs
6.8μH	=	output capacitor	2.2μF/50V	2pcs
10μH	=	output capacitor	2.2μF/50V	3pcs

This value is just examples, please made sure the final judgment is under an enough evaluation.

●The separation of the IC power supply and coil power supply

This IC can work in separating the power source in both IC power supply and coil power supply. With this application, it can obtain that decrease of IC power consumption, and the applied voltage exceeds IC rating 26V.

That application is shown in below Fig.14. The higher voltage source is applied to the power source of coil that is connected from 4.2V to 5.5V into IC VBAT, please follow the recommend design in Fig.14. It connects VBAT terminal and VREG terminal together at IC outside.

When the coil power supply is applied, it is no any problem even though IC power supply is the state of 0V. Although IC power supply is set to 0V, pull-down resistance is arranged for the power off which cuts off the leak route from coil power supply in IC inside, the leak route is cut off. And, there is no power on-off sequence of coil power supply and IC power supply.

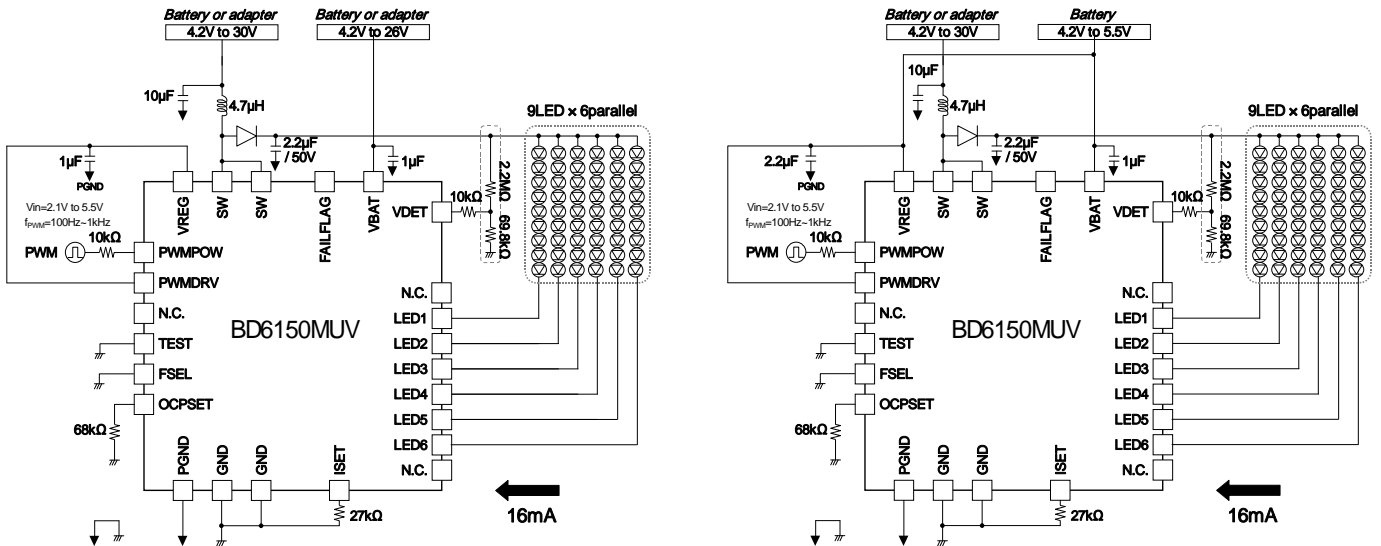

Fig.37 Application at the time of power supply isolation (6parallel)

● Selection of external parts

Recommended external parts are as shown below.

When to use other parts than these, select the following equivalent parts.

• Coil

Value	Manufacturer	Product number	Size			DC current (mA)	DCR (Ω)
			Vertical	Horizontal	Height (MAX)		
4.7μH	TOKO	A915AY-4R7M	5.2	5.2	3.0	1870	0.045
4.7μH	TOKO	B1015AS-4R7M	8.4	8.3	4.0	3300	0.038
4.7μH	TDK	LTF5022T-4R7N2R0-LC	5.0	5.2	2.2	2000	0.073
10μH	TOKO	A915AY-100M	5.2	5.2	3.0	1870	0.090
10μH	TDK	LTF5022T-100M1R4-LC	5.0	5.2	2.2	1400	0.140

• Capacitor

Value	Pressure	Manufacturer	Product number	Size			TC	Capa Tolerance
				Vertical	Horizontal	Height		
[Supply voltage capacitor]								
2.2μF	10V	MURATA	GRM188B31A225K	1.6	0.8	0.8±0.1	B	+/-10%
4.7μF	25V	MURATA	GRM319R61E475K	3.2	1.6	0.85±0.1	X5R	+/-10%
4.7μF	25V	MURATA	GRM21BR61E475K	2.0	1.25	1.25±0.1	X5R	+/-10%
10μF	25V	MURATA	GRM31CB31E106K	3.2	1.6	1.6±0.2	B	+/-10%
10μF	10V	MURATA	GRM219R61A106K	2.0	1.25	0.85±0.15	X5R	+/-10%
[Smoothing capacitor for built-in regulator]								
1μF	10V	MURATA	GRM188B10J105K	1.6	0.8	0.8±0.1	B	+/-10%
4.7μF	10V	MURATA	GRM219B31A475K	2.0	1.25	0.85±0.1	B	+/-10%
[Output capacitor]								
1μF	50V	MURATA	GRM31MB31H105K	3.2	1.6	1.15±0.1	B	+/-10%
1μF	50V	MURATA	GRM21BB31H105K	2.0	1.25	1.25±0.1	B	+/-10%
2.2μF	50V	TDK	C3225JB1H225K	3.2	2.5	2.0±0.2	B	+/-10%
2.2μF	50V	MURATA	GRM31CB31H225K	3.2	1.6	1.6±0.2	B	+/-10%
0.33μF	50V	MURATA	GRM219B31H334K	2.0	1.25	0.85±0.1	B	+/-10%

• Resistor

Value	Tolerance	Manufacturer	Product number	Size		
				Vertical	Horizontal	Height
10kΩ	±0.5%	ROHM	MCR03EZPD1002	1.6	0.8	0.45
15kΩ	±0.5%	ROHM	MCR03EZPD1502	1.6	0.8	0.45
18kΩ	±0.5%	ROHM	MCR03EZPD1802	1.6	0.8	0.45
22kΩ	±0.5%	ROHM	MCR03EZPD2202	1.6	0.8	0.45
24kΩ	±0.5%	ROHM	MCR03EZPD2402	1.6	0.8	0.45
27kΩ	±0.5%	ROHM	MCR03EZPD2702	1.6	0.8	0.45
30kΩ	±0.5%	ROHM	MCR03EZPD3002	1.6	0.8	0.45
33kΩ	±0.5%	ROHM	MCR03EZPD3302	1.6	0.8	0.45
56kΩ	±0.5%	ROHM	MCR03EZPD5602	1.6	0.8	0.45
62kΩ	±0.5%	ROHM	MCR03EZPD6202	1.6	0.8	0.45
68kΩ	±0.5%	ROHM	MCR03EZPD6802	1.6	0.8	0.45
75kΩ	±0.5%	ROHM	MCR03EZPD7502	1.6	0.8	0.45
2.2MΩ	±0.5%	ROHM	MCR03EZPD2204	1.6	0.8	0.45

• SBD

Pressure	Manufacturer	Product number	Size		
			Vertical	Horizontal	Height
60V	ROHM	RB160M-60	3.5	1.6	0.8

The coil is the part that is most influential to efficiency. Select the coil whose direct current resistor (DCR) and current - inductance characteristic is excellent. BD6xxx is designed for the inductance value of 4.7μH. Don't use the inductance value less than 3.3μH. Select a capacitor of ceramic type with excellent frequency and temperature characteristics. Further, select Capacitor to be used with small direct current resistance, and pay sufficient attention to the PCB layout.

●PCB Layout

In order to make the most of the performance of this IC, its PCB layout is very important. Characteristics such as efficiency and ripple and the likes change greatly with layout patterns, which please note carefully.

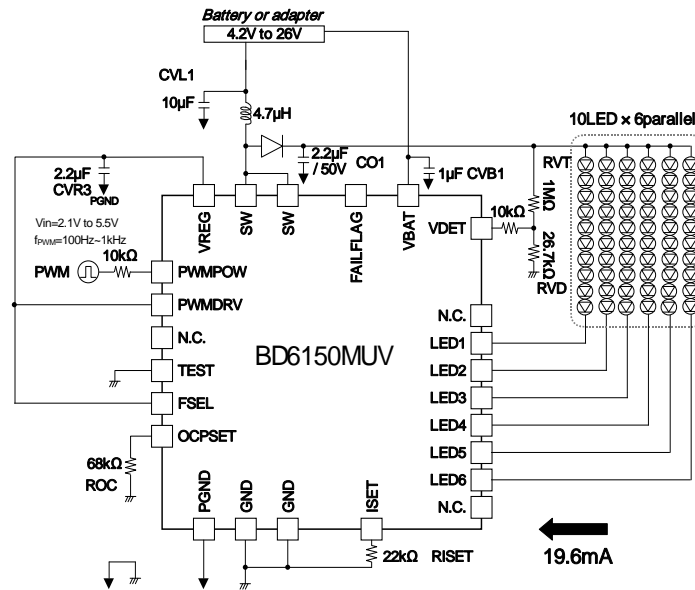

Fig. 38 PCB Layout

<Input capacitor CVL1 (10µF) for coil>

Connect input capacitor CVL1 (10µF) as close as possible between coil L1 and PGND.

<Input bypath capacitor CVB1 (1µF) for IC>

Put input bypath capacitor CVB1 (1µF) as close as possible between VBAT and PGND pin.

<Smoothing capacitor CVR3(2.2µF) of the regulator>

Connect smoothing capacitor CVR3(2.2 µ F) as close as possible between VREG pin and PGND.

<Schottky barrier diode SBD>

Connect schottky barrier diode SBD as close as possible between coil1and SW pin.

<Output capacitor CO1>

Connect output capacitor CO1 between cathode of SBD and PGND.

Make both PGND sides of CVL1 and CO1 as close as possible.

<LED current setting resistor RISET(22kΩ)>>

Connect LED current setting resistor RISET(22kΩ) as close as possible between ISET pin and GND.

There is possibility to oscillate when capacity is added to ISET terminal, so pay attention that capacity isn't added.

<Over current limit setting resistor ROC(68kΩ)>

Connect Over current limit setting resistor ROC(68kΩ) as close as possible between OCPSET pin and GND.

< Over current limit setting resistor RVT(2.2MΩ) & RVD(56kΩ)>

Put over current limit setting resistor RVT(2.2MΩ) & RVD(56kΩ) as close as possible VDET pin so as not to make the wire longer, which possibly causes the noise and also detects over voltage protection by mistake.

<Connect to GND and PGND>

GND is analog ground, and PGND is power ground. PGND might cause a lot of noise due to the coil current of PGND. Try to connect with analog ground, after smoothing with input capacitor CVL1 and output capacitor CO1.

<Heat radiation of back side PAD>

PAD is used for improving the efficiency of IC heat radiation. Solder PAD to GND pin (analog ground).

Moreover, connect ground plane of board using via as shown in the patterns of next page.

The efficiency of heat radiation improves according to the area of ground plane.

<Others>

When those pins are not connected directly near the chip, influence is give to the performance of BD6150, and may limit the current drive performance. As for the wire to the inductor, make its resistance component small so as to reduce electric power consumption and increase the entire efficiency.

The layout pattern in consideration of these is shown in the next page.

●Recommended PCB layout pattern

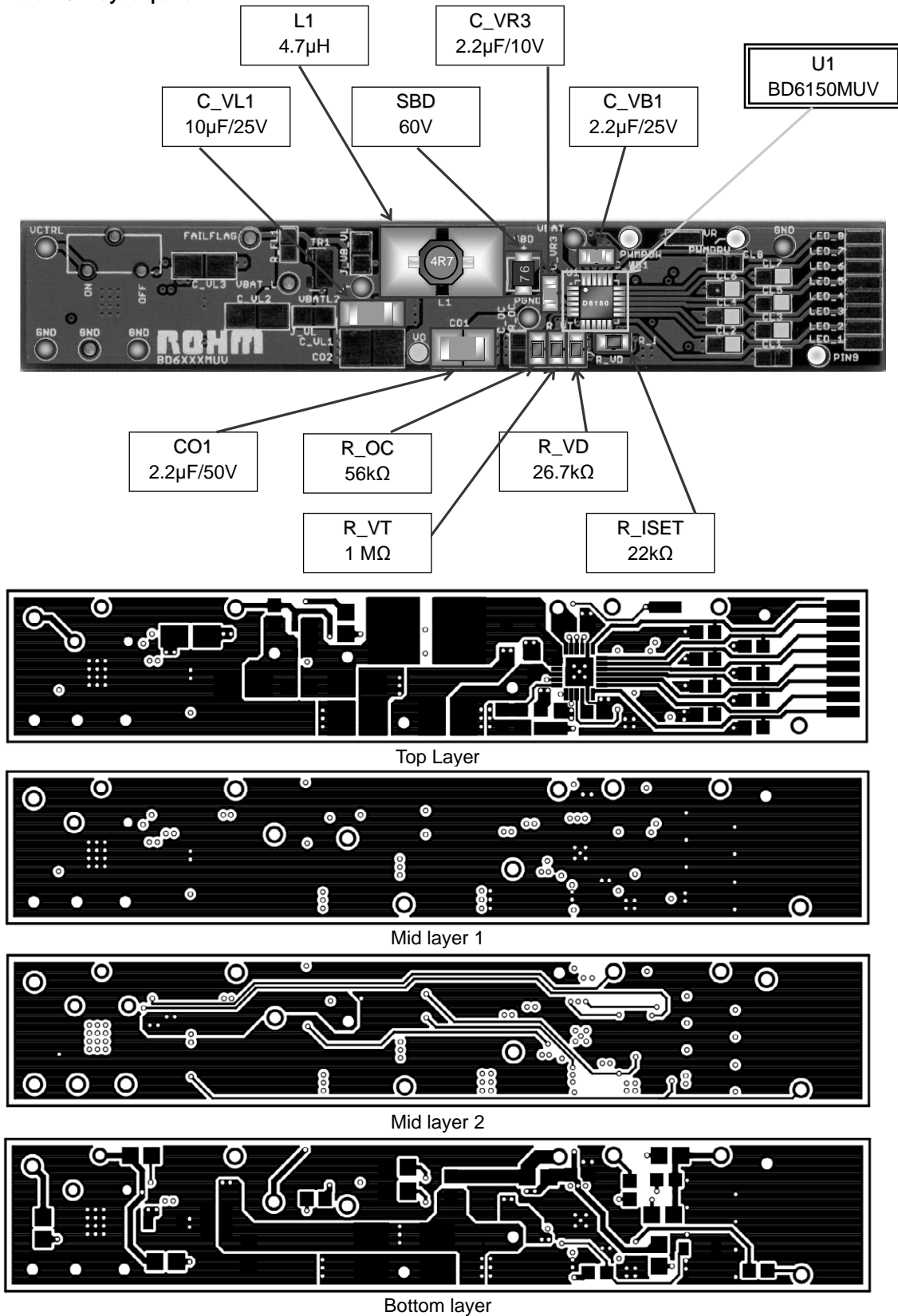

Fig. 39 PCB layout patterns

●About heat loss

In heat design, operate the DC/DC converter in the following condition.
 (The following temperature is a guarantee temperature, so consider the margin.)

1. Ambient temperature T_a must be less than 85°C.
2. The loss of IC must be less than dissipation P_d .

●Application example

- LED current setting controlled ISETH resistor.
 21.5kΩ : 20.1mA
 27.0kΩ : 16.0mA
 14.7kΩ : 29.59mA
- Brightness control
 Please input PWM pulse from PWMPW or PWMDRV terminal.
 Please refer electrical characteristics p.3 and function (p.12).

15inch panel

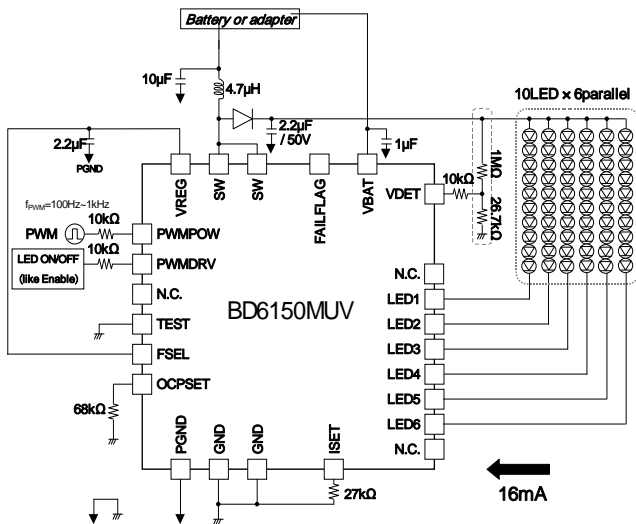

Fig.40 10 series × 6parallel, LED current 16mA setting
 Switching frequency 750kHz setting example
 Power control PWM application

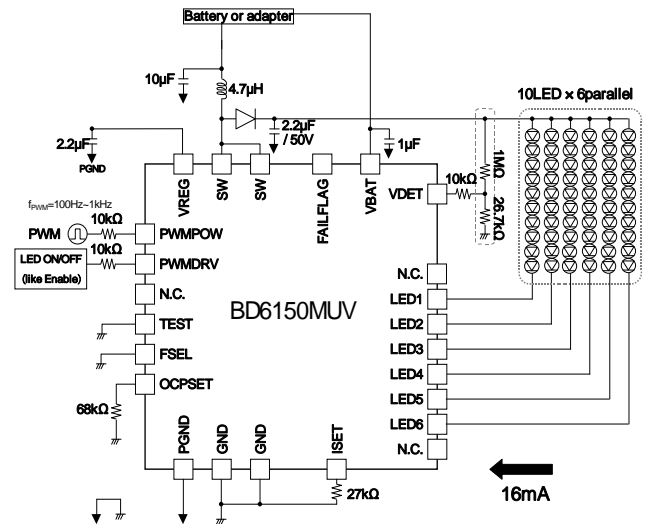

Fig.41 10 series × 6 parallel, LED current16mA,
 Switching frequency 1250kHz example
 Power control PWM application

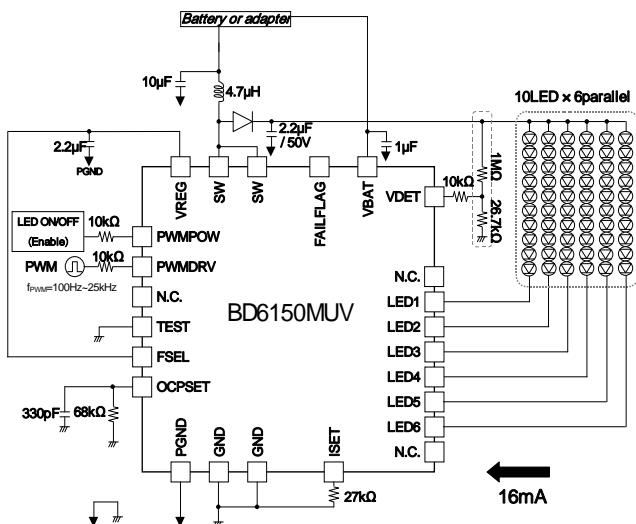

Fig.42 10 series × 6parallel, LED current 16mA setting
 Switching frequency 750kHz setting example
 Current driver PWM application

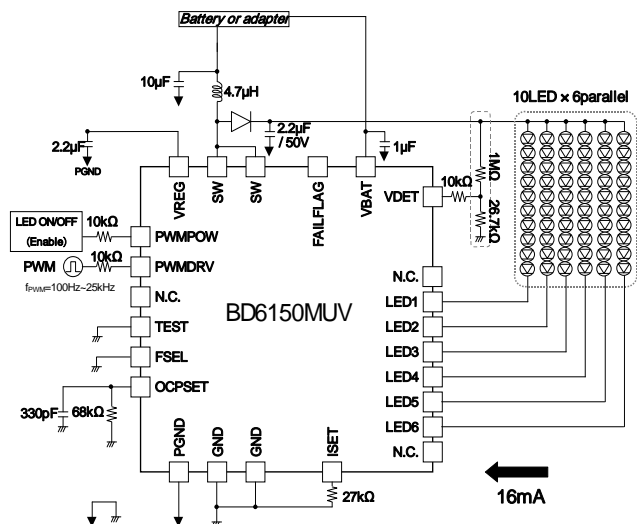

Fig.43 10 series × 6parallel, LED current 16mA setting
 Switching frequency 1250kHz setting example
 Current driver PWM application

13~14inch panel

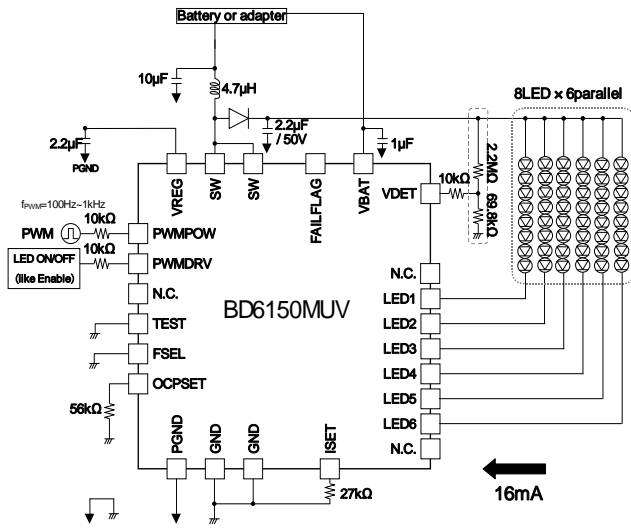

Fig.44 8series × 6parallel LED current 16mA setting, Switching frequency 1250kHz setting example Power control PWM application

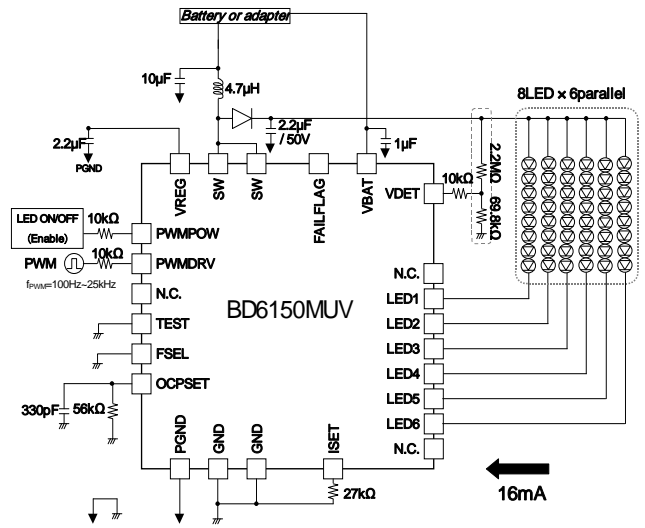

Fig.45 8series × 6parallel, LED current 16mA setting, Switching frequency 1250kHz setting example Current driver PWM application

10~12inch panel

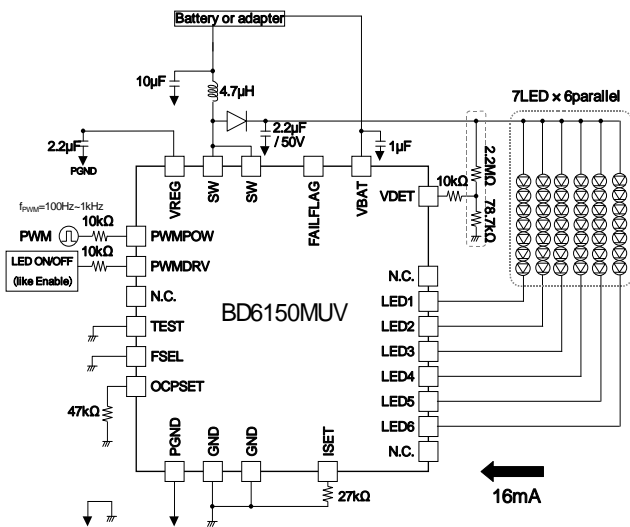

Fig.46 7series × 6parallel, LED current 16mA setting, Switching frequency 1250kHz setting example Power control PWM application

7inch panel

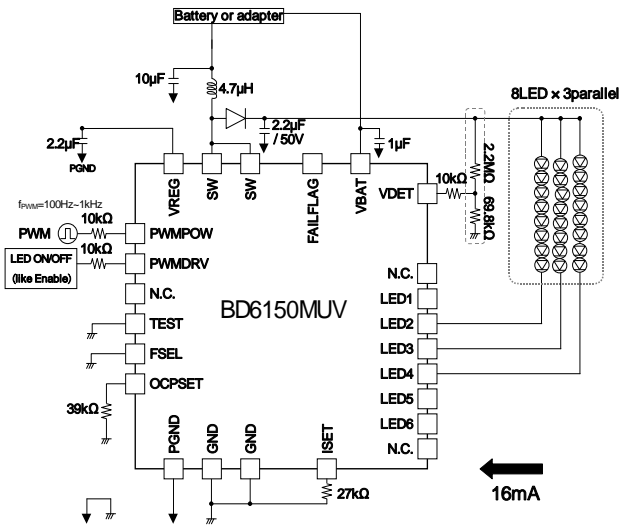

Fig.47 8series × 3parallel, LED current 16mA setting, Switching frequency 1250kHz setting example Power control PWM application

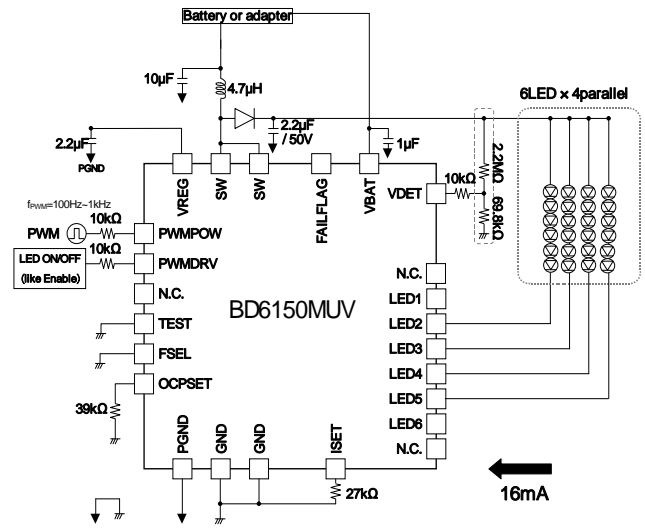

Fig.48 6series × 4parallel, LED current 16mA setting, Switching frequency 1250kHz setting example Power control PWM application

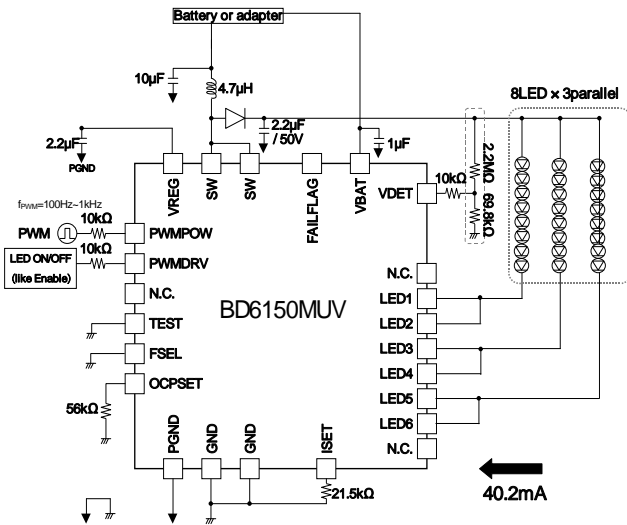

Fig.49 8series × 3parallel, LED current 40.2mA setting, Switching frequency 1250kHz setting example Power control PWM application

5inch panel

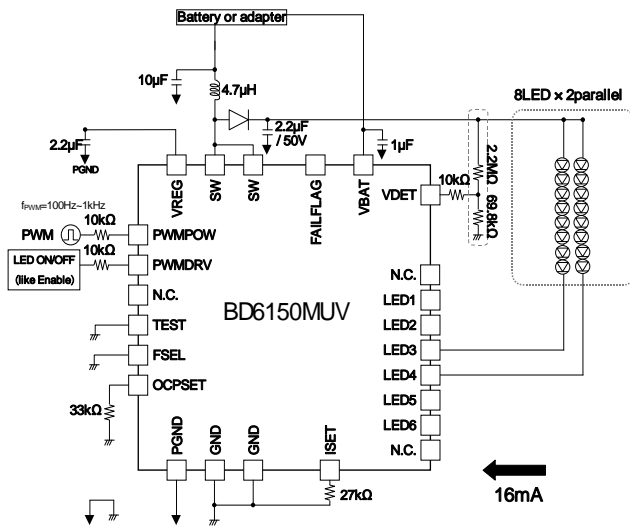

Fig.50 8series × 2parallel, LED current 16mA setting, Switching frequency 125kHz setting example Power control PWM application

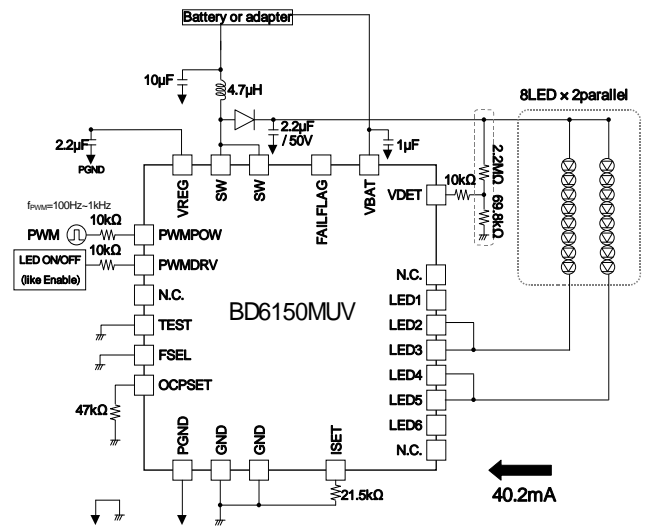

Fig.51 8series × 2parallel, LED current 40.2mA setting, Switching frequency 125kHz setting example Power control PWM application

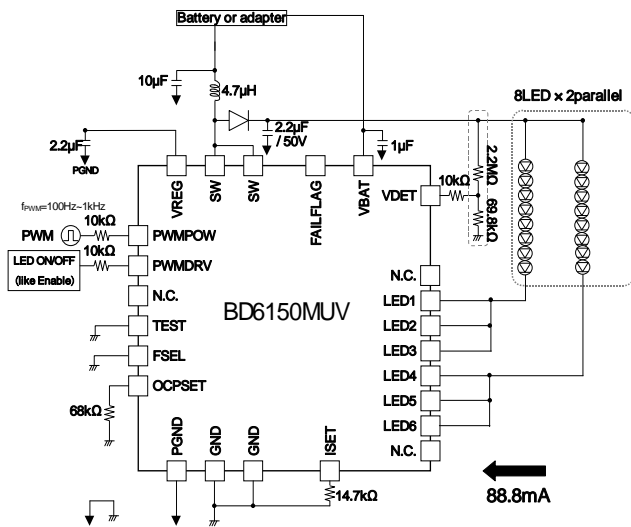

Fig.52 8series × 2parallel, LED current 88.8mA setting, Switching frequency 125kHz setting example Power control PWM application

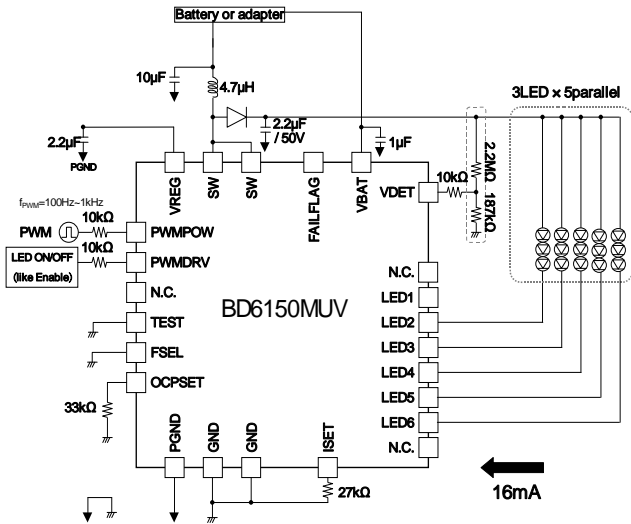

Fig.53 3series × 5parallel, LED current 16mA setting, Switching frequency 125kHz setting example Power control PWM application

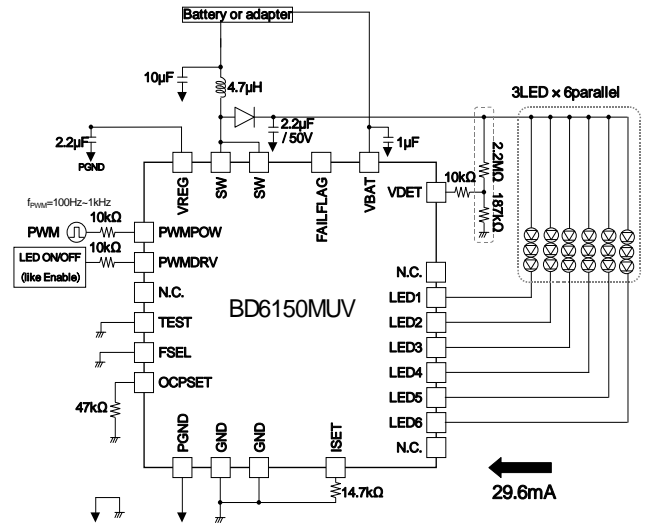

Fig.54 3series × 6parallel, LED current 29.6mA setting, Switching frequency 125kHz setting example Power control PWM application

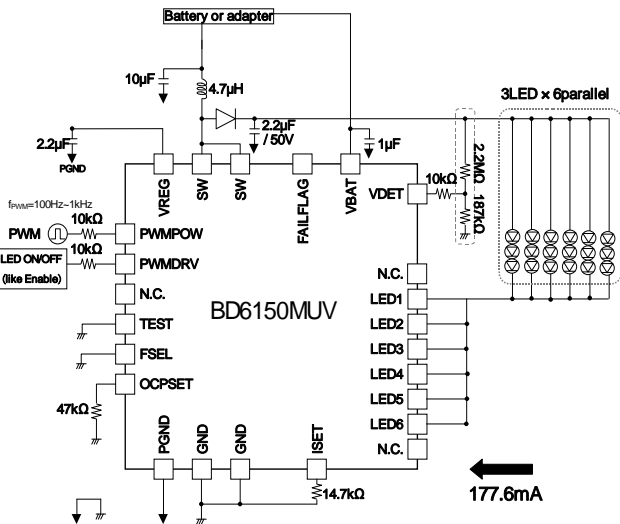

Fig.55 3series × 6parallel, LED current 177.6mA setting, Switching frequency 125kHz setting example Power control PWM application

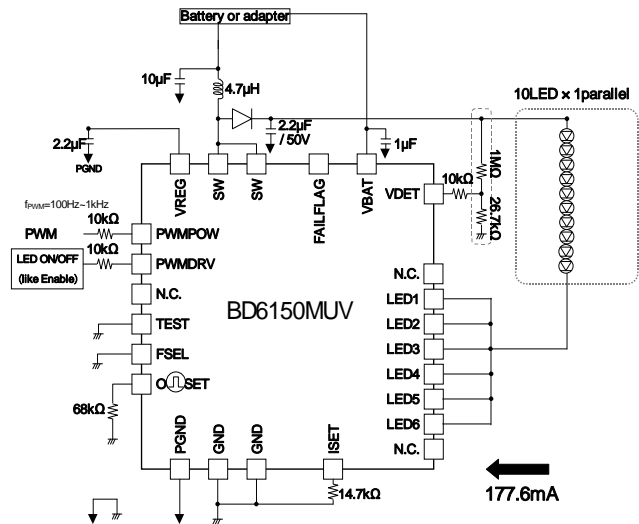

Fig.56 10series × 1parallel, LED current 177.6mA setting, Switching frequency 125kHz setting example Power control PWM application

●Notes for use

- (1) Absolute Maximum Ratings
An excess in the absolute maximum ratings, such as supply voltage, temperature range of operating conditions, etc., can break down devices, thus making impossible to identify breaking mode such as a short circuit or an open circuit. If any special mode exceeding the absolute maximum ratings is assumed, consideration should be given to take physical safety measures including the use of fuses, etc.
- (2) Operating conditions
These conditions represent a range within which characteristics can be provided approximately as expected. The electrical characteristics are guaranteed under the conditions of each parameter.
- (3) Reverse connection of power supply connector
The reverse connection of power supply connector can break down ICs. Take protective measures against the breakdown due to the reverse connection, such as mounting an external diode between the power supply and the IC's power supply terminal.
- (4) Power supply line
Design PCB pattern to provide low impedance for the wiring between the power supply and the GND lines. In this regard, for the digital block power supply and the analog block power supply, even though these power supplies has the same level of potential, separate the power supply pattern for the digital block from that for the analog block, thus suppressing the diffraction of digital noises to the analog block power supply resulting from impedance common to the wiring patterns. For the GND line, give consideration to design the patterns in a similar manner.
Furthermore, for all power supply terminals to ICs, mount a capacitor between the power supply and the GND terminal. At the same time, in order to use an electrolytic capacitor, thoroughly check to be sure the characteristics of the capacitor to be used present no problem including the occurrence of capacity dropout at a low temperature, thus determining the constant.
- (5) GND voltage
Make setting of the potential of the GND terminal so that it will be maintained at the minimum in any operating state. Furthermore, check to be sure no terminals are at a potential lower than the GND voltage including an actual electric transient.
- (6) Short circuit between terminals and erroneous mounting
In order to mount ICs on a set PCB, pay thorough attention to the direction and offset of the ICs. Erroneous mounting can break down the ICs. Furthermore, if a short circuit occurs due to foreign matters entering between terminals or between the terminal and the power supply or the GND terminal, the ICs can break down.
- (7) Operation in strong electromagnetic field
Be noted that using ICs in the strong electromagnetic field can malfunction them.
- (8) Inspection with set PCB
On the inspection with the set PCB, if a capacitor is connected to a low-impedance IC terminal, the IC can suffer stress. Therefore, be sure to discharge from the set PCB by each process. Furthermore, in order to mount or dismount the set PCB to/from the jig for the inspection process, be sure to turn OFF the power supply and then mount the set PCB to the jig. After the completion of the inspection, be sure to turn OFF the power supply and then dismount it from the jig. In addition, for protection against static electricity, establish a ground for the assembly process and pay thorough attention to the transportation and the storage of the set PCB.
- (9) Input terminals
In terms of the construction of IC, parasitic elements are inevitably formed in relation to potential. The operation of the parasitic element can cause interference with circuit operation, thus resulting in a malfunction and then breakdown of the input terminal. Therefore, pay thorough attention not to handle the input terminals, such as to apply to the input terminals a voltage lower than the GND respectively, so that any parasitic element will operate. Furthermore, do not apply a voltage to the input terminals when no power supply voltage is applied to the IC. In addition, even if the power supply voltage is applied, apply to the input terminals a voltage lower than the power supply voltage or within the guaranteed value of electrical characteristics.
- (10) Ground wiring pattern
If small-signal GND and large-current GND are provided, It will be recommended to separate the large-current GND pattern from the small-signal GND pattern and establish a single ground at the reference point of the set PCB so that resistance to the wiring pattern and voltage fluctuations due to a large current will cause no fluctuations in voltages of the small-signal GND. Pay attention not to cause fluctuations in the GND wiring pattern of external parts as well.
- (11) External capacitor
In order to use a ceramic capacitor as the external capacitor, determine the constant with consideration given to a degradation in the nominal capacitance due to DC bias and changes in the capacitance due to temperature, etc.
- (12) Thermal shutdown circuit (TSD)
When junction temperatures become 175°C (typ) or higher, the thermal shutdown circuit operates and turns a switch OFF. The thermal shutdown circuit, which is aimed at isolating the LSI from thermal runaway as much as possible, is not aimed at the protection or guarantee of the LSI. Therefore, do not continuously use the LSI with this circuit operating or use the LSI assuming its operation.
- (13) Thermal design
Perform thermal design in which there are adequate margins by taking into account the permissible dissipation (Pd) in actual states of use.
- (14) Selection of coil
Select the low DCR inductors to decrease power loss for DC/DC converter.

Notes

No copying or reproduction of this document, in part or in whole, is permitted without the consent of ROHM Co.,Ltd.

The content specified herein is subject to change for improvement without notice.

The content specified herein is for the purpose of introducing ROHM's products (hereinafter "Products"). If you wish to use any such Product, please be sure to refer to the specifications, which can be obtained from ROHM upon request.

Examples of application circuits, circuit constants and any other information contained herein illustrate the standard usage and operations of the Products. The peripheral conditions must be taken into account when designing circuits for mass production.

Great care was taken in ensuring the accuracy of the information specified in this document. However, should you incur any damage arising from any inaccuracy or misprint of such information, ROHM shall bear no responsibility for such damage.

The technical information specified herein is intended only to show the typical functions of and examples of application circuits for the Products. ROHM does not grant you, explicitly or implicitly, any license to use or exercise intellectual property or other rights held by ROHM and other parties. ROHM shall bear no responsibility whatsoever for any dispute arising from the use of such technical information.

The Products specified in this document are intended to be used with general-use electronic equipment or devices (such as audio visual equipment, office-automation equipment, communication devices, electronic appliances and amusement devices).

The Products specified in this document are not designed to be radiation tolerant.

While ROHM always makes efforts to enhance the quality and reliability of its Products, a Product may fail or malfunction for a variety of reasons.

Please be sure to implement in your equipment using the Products safety measures to guard against the possibility of physical injury, fire or any other damage caused in the event of the failure of any Product, such as derating, redundancy, fire control and fail-safe designs. ROHM shall bear no responsibility whatsoever for your use of any Product outside of the prescribed scope or not in accordance with the instruction manual.

The Products are not designed or manufactured to be used with any equipment, device or system which requires an extremely high level of reliability the failure or malfunction of which may result in a direct threat to human life or create a risk of human injury (such as a medical instrument, transportation equipment, aerospace machinery, nuclear-reactor controller, fuel-controller or other safety device). ROHM shall bear no responsibility in any way for use of any of the Products for the above special purposes. If a Product is intended to be used for any such special purpose, please contact a ROHM sales representative before purchasing.

If you intend to export or ship overseas any Product or technology specified herein that may be controlled under the Foreign Exchange and the Foreign Trade Law, you will be required to obtain a license or permit under the Law.





Thank you for your accessing to ROHM product informations.
More detail product informations and catalogs are available, please contact us.

ROHM Customer Support System

<http://www.rohm.com/contact/>

Looking for pricing, stock, or lifecycle information?

Click below to explore more details on WIN SOURCE:

-  [View BD6150MUV-E2 on WIN SOURCE](#)
-  [Rohm Semiconductor](#) Information

Optimize Your Supply Chain with WIN SOURCE Solutions

-  Global Sourcing Solution
-  Obsolete Management
-  Cost Control Management
-  Shortage Management
-  Alternative Solution
-  Excess Inventory Management