



**THE DATASHEET OF
FSA4480UCX**



USB Type-C® Analog Audio Switch with Protection Function

FSA4480

Description

FSA4480 is a high performance USB Type-C port multimedia switch which supports analog audio headsets. FSA4480 allows the sharing of a common USB Type-C port to pass USB2.0 signal, analog audio, sideband use wires and analog microphone signal. FSA4480 also supports high voltage on SBU port and USB port on USB Type-C receptacle side.

Features

- Power Supply: V_{CC} , 2.7 V to 5.5 V
- USB High Speed (480 Mbps) Switch:
 - ◆ SDD_{21} -3dB bandwidth: 950 MHz
 - ◆ 3 Ω R_{ON} Typical
- Audio Switch
 - ◆ Negative Rail Capability: -3 V to +3 V
 - ◆ THD+N = -110 dB; 1 V_{RMS} , $f = 20$ Hz ~ 20 kHz, 32 W Load
 - ◆ 1 Ω R_{ON} Typical
- High Voltage Protection
 - ◆ 20 V DC Tolerance on Connector Side Pins
 - ◆ Over Voltage Protection: $V_{TH} = 5$ V (Typ)
- OMTF and CTIA Pinout Support
- Support Audio Sense Path
- 25-Ball WLCSP Package (2.24 mm x 2.28 mm)

Applications

- Mobile Phone, Tablet, Notebook PC, Media Player

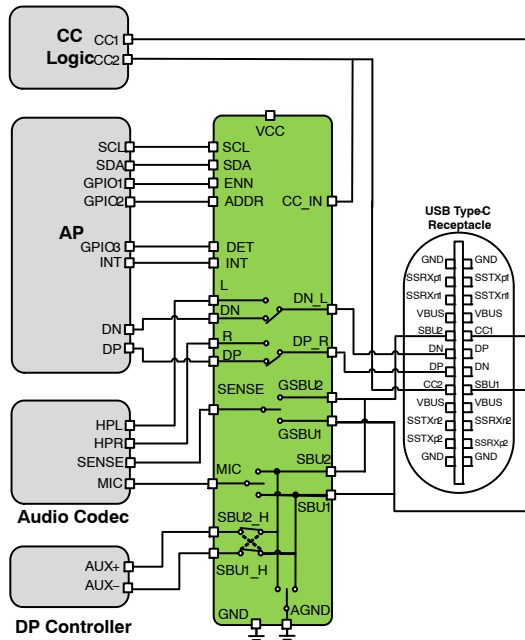
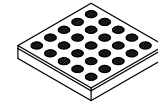
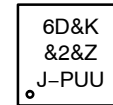

Figure 1. Application Block Diagram



WLCSP25
CASE 567UZ

MARKING DIAGRAM



- 6D = Specific Device Code
 - &K = 2-digits Lot Run Traceability Code
 - &2 = 2-digits Date Code (YW)
 - &Z = Assembly Location
 - J- = X- Coordinates with dash as separator*
 - P = Y Coordinates*
 - UU = Two Digit Wafer ID*
- *For onsemi internal use only.

ORDERING INFORMATION

Part Number	Package	Marking
FSA4480UCX	WLCSP25 (Pb-Free)	6D

PIN CONFIGURATION

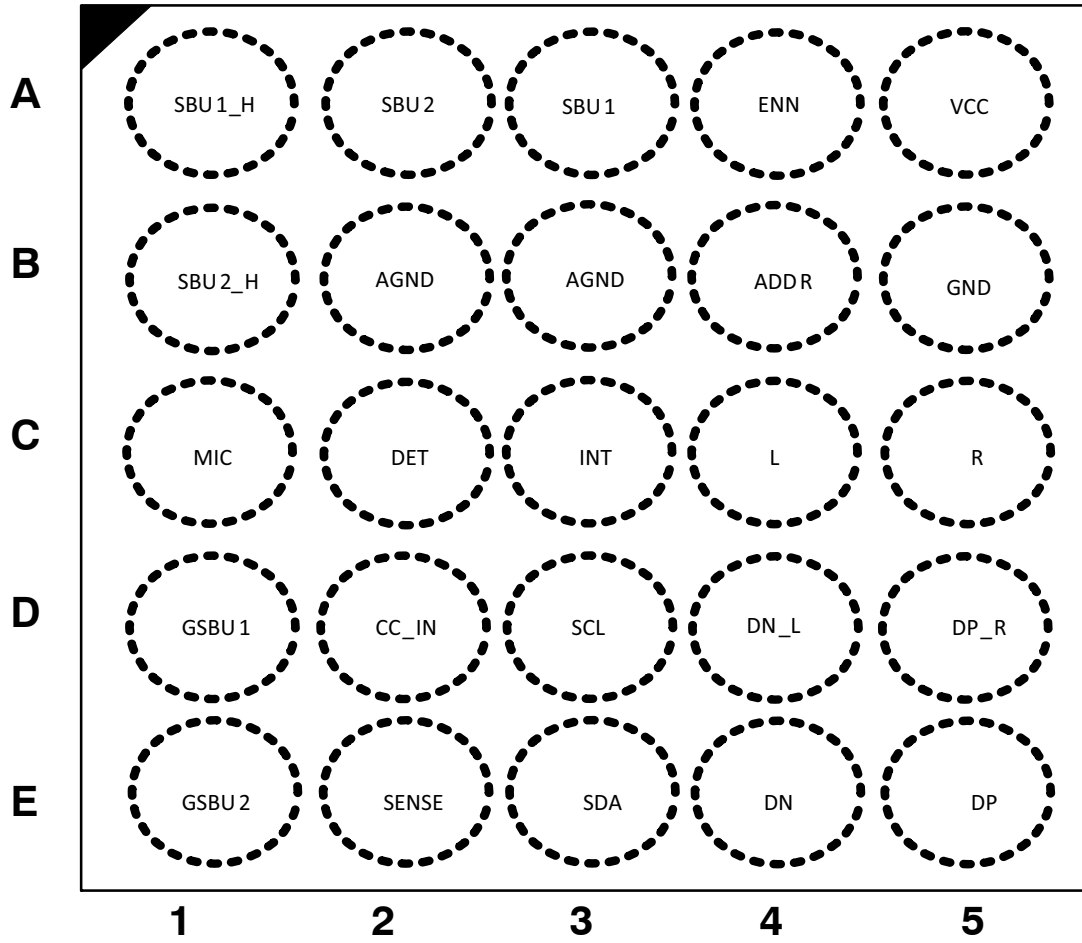

Figure 2. Pin Assignment (Top Through View)

FSA4480

Table 1. PIN DESCRIPTIONS

No.	Pin	Name	Description
1	A5	VCC	Power Supply (2.7 to 5.5 V)
2	B5	GND	Chip ground
3	D5	DP_R	USB/Audio Common Connector
4	D4	DN_L	USB/Audio Common Connector
5	E5	DP	USB Data (Differential +)
6	E4	DN	USB Data (Differential -)
7	C5	R	Audio – Right Channel
8	C4	L	Audio – Left Channel
9	A3	SBU1	Sideband use wire 1
10	A2	SBU2	Sideband use wire 2
11	C1	MIC	Microphone signal
12	B2	AGND	Audio signal ground
13	B3	AGND	Audio signal ground
14	E2	SENSE	Audio ground reference output
15	C3	INT	I ² C Interrupt output, active low (open drain)
16	D2	CC_IN	Audio accessory attachment detection input
17	D1	GSBU1	Audio sense path 1 to headset jack GND
18	E1	GSBU2	Audio sense path 2 to headset jack GND
19	C2	DET	Push-pull output. When CC_IN > 1.5 V, DET is low and CC_IN < 1.2 V, DET is high
20	D3	SCL	I ² C clock
21	E3	SDA	I ² C data
22	B1	SBU2_H	Host Side Sideband Use Wire 2
23	A1	SBU1_H	Host Side Sideband Use Wire 1
24	A4	ENN	Chip Enable, active low, internal pull-down by 470 k Ω
25	B4	ADDR	I ² C slave address pin

FSA4480

Table 2. ABSOLUTE MAXIMUM RATINGS

Symbol	Parameter		Min.	Max.	Unit
V _{CC}	Supply Voltage from VCC		-0.5	6.5	V
V _{CC_IN}	V _{CC_IN} to GND		-0.5	20	V
V _{SW_C}	V _{DP_R} to GND, V _{DN_L} to GND		-3.5	20	V
V _{SW_USB}	V _{DP} to GND, V _{DN} to GND		-0.5	6.5	V
V _{SW_Audio}	V _L to GND, V _R to GND		-3.6	6.5	V
V _{V_SBU/GSBU}	V _{SBU1} to GND, V _{SBU2} to GND, V _{GSBU1} to GND, V _{GSBU1} to GND		-0.5	20	V
V _{VSBU_H}	V _{SBU1_H} to GND, V _{SBU2_H} to GND		-0.5	6.5	V
V _{I/O}	SENSE, MIC, DET, INT, to GND		-0.5	6.5	V
V _{CNTRL}	Control Input Voltage	SDA, SCL, ENN, ADDR	-0.5	6.5	V
I _{SW_Audio}	Switch I/O Current, Audio Path		-250	250	mA
I _{SW_USB}	Switch I/O Current, USB Path		-	100	mA
I _{SW_MIC}	Switch I/O Current, MIC to SBU1 or SBU2		-	50	mA
I _{SW_SBU}	Switch I/O Current, SBU _x to SBU _{x_H}		-	50	mA
I _{SW_SENSE}	Switch I/O Current, SENSE to GSBU1 or GSBU2		-	100	mA
I _{SW_AGND}	Switch I/O Current, AGND to SBU1 or SBU2		-	500	mA
I _{IK}	DC Input Diode Current		-50	-	mA
ESD	Human Body Model, ANSI/ESDA/JEDEC JS-001-2012	Connector side and power pins: VCC, SBU1, SBU2, DP_R, DN_L, GSBU1, GSBU2, CC_IN	4	-	kV
ESD	Human Body Model, ANSI/ESDA/JEDEC JS-001-2012	Host side pins: the rest pins	2	-	kV
ESD	Charged Device Model, JEDEC: JESD22-C101		1	-	kV
T _A	Absolute Maximum Operating Temperature		-40	85	°C
T _{STG}	Storage Temperature		-65	150	°C

Stresses exceeding those listed in the Maximum Ratings table may damage the device. If any of these limits are exceeded, device functionality should not be assumed, damage may occur and reliability may be affected.

FSA4480

Table 3. RECOMMENDED OPERATING CONDITIONS

Symbol	Parameter	Min.	Typ.	Max.	Unit
POWER					
V_{CC}	Supply Voltage	2.7	–	5.5	V
USB SWITCH					
V_{SW_USB}	V_{DP} to GND, V_{DN} to GND, V_{DP_R} to GND, V_{DN_L} to GND	0	–	3.6	V
AUDIO SWITCH					
V_{SW_Audio}	V_{DP_R} to GND, V_{DN_L} to GND, V_L to GND, V_R to GND	–3.6	–	3.6	V
MIC SWITCH					
V_{SBU_MIC}	V_{SBU1} to GND, V_{SBU2} to GND, V_{MIC} to GND	0	–	3.6	V
SENSE SWITCH					
$V_{G\text{SBU_SEN}}$	$V_{G\text{SBU1}}$ to GND, $V_{G\text{SBU2}}$ to GND, V_{SENSE} to GND	0	–	3.6	V
SBU TO SBUX_H SWITCH					
$V_{G\text{SBU}}$	V_{SBU1} to GND, V_{SBU2} to GND, V_{SBU1_H} to GND, V_{SBU2_H} to GND	0	–	3.6	V
CC_IN PIN					
V_{CC_IN}	V_{CC_IN} , to GND	0	–	5.5	V
CONTROL VOLTAGE (ENN/SDA/SCL)					
V_{IH}	Input Voltage High	1.3	–	V_{CC}	V
V_{IL}	Input Voltage Low	–	–	0.5	V
OPERATING TEMPERATURE					
T_A	Ambient Operating Temperature	–40	25	+85	°C

Functional operation above the stresses listed in the Recommended Operating Ranges is not implied. Extended exposure to stresses beyond the Recommended Operating Ranges limits may affect device reliability.

FSA4480

Table 4. DC ELECTRICAL CHARACTERISTICS

($V_{CC} = 2.7\text{ V to }5.5\text{ V}$, $V_{CC}(\text{Typ.}) = 3.3\text{ V}$, $T_A = -40^\circ\text{C to }85^\circ\text{C}$, and $T_A(\text{Typ.}) = 25^\circ\text{C}$, unless otherwise specified.)

Symbol	Parameter	Condition	Power	Min.	Typ.	Max.	Unit
I_{CC}	Supply Current	USB switches on, SBUx to SBUx_H switches on	$V_{CC}: 2.7\text{ V to }5.5\text{ V}$	-	-	65	μA
		Audio switches on, MIC switch on and Audio GND switch on		-	-	60	μA
I_{CCZ}	Quiescent Current	ENN = L, 04H'b7 = 0		-	-	5	μA

USB/AUDIO COMMON PINS: DP/R, DN_L

I_{OZ}	Off Leakage Current of DP_R and DN_L	DN_L, DP_R = -3 V to 3.6 V	$V_{CC}: 2.7\text{ V to }5.5\text{ V}$	-3.0	-	3.0	μA
I_{OFF}	Power-Off Leakage Current of DP_R and DN_L	DN_L, DP_R = 0 V to 3.6 V	Power off	-3.0	-	3.0	μA
V_{OV_TRIP}	Input OVP Lockout	Rising edge	$V_{CC}: 2.7\text{ V to }5.5\text{ V}$	4.5	5	5.3	V
V_{OV_HYS}	Input OVP Hysteresis			-	0.3	-	V

AUDIO SWITCH

I_{ON}	On Leakage Current of Audio Switch	DN_L, DP_R = -3 V to 3.0 V, DP, DN, R, L = Float	$V_{CC}: 2.7\text{ V to }5.5\text{ V}$	-2.5	-	2.5	μA
I_{OFF}	Power-Off Leakage Current of L and R	L, R = 0 V to 3 V; DP_R, DN_L = Float	Power off	-1.0	-	1.0	μA
R_{ON_AUDIO}	Audio Switch On Resistance	$I_{SW} = 100\text{ mA}$, $V_{SW} = -3\text{ V to }3\text{ V}$	$V_{CC}: 2.7\text{ V to }5.5\text{ V}$	-	1.0	2.1	Ω
R_{SHUNT}	Pull Down Resistor on R/L Pin when Audio Switch is Off	L = R = 3 V		6	10	14	k Ω

USB SWITCH

I_{ON}	On Leakage Current of USB Switch	DN_L, DP_R = 0 V to 3.6 V, DP, DN, R, L = Float	$V_{CC}: 2.7\text{ V to }5.5\text{ V}$	-3.0	-	3.0	μA
I_{OZ}	Off Leakage Current of DP and DN	DN, DP = 0 V to 3.6 V		-3.0	-	3.0	μA
I_{OFF}	Power-Off Leakage Current of DP and DN	DN, DP = 0 V to 3.6 V	Power off	-3.0	-	3.0	μA
R_{ON_USB}	USB Switch On Resistance	$I_{SW} = 8\text{ mA}$, $V_{SW} = 0.4\text{ V}$	$V_{CC}: 2.7\text{ V to }5.5\text{ V}$	-	3.0	5.2	Ω

SENSE SWITCH

I_{ON}	Sense Path Leakage Current	GSBUx = 0 V to 1 V, SENSE is floating	$V_{CC}: 2.7\text{ V to }5.5\text{ V}$	-2.0	-	2.0	μA
R_{ON_SENSE}	SENSE Switch On Resistance	$I_{SW} = 100\text{ mA}$, $V_{SW} = 1\text{ V}$	$V_{CC}: 2.7\text{ V to }5.5\text{ V}$	0.20	0.30	0.40	Ω
I_{OZ}	Off Leakage Current of SENSE	Sense = 0 V to 1.0 V		-2.0	-	2.0	μA
	Off Leakage Current of GSBUx	GSBUx = 0 V to 1.0 V		-2.0	-	2.0	μA
		GSBUx = 1 V to 3.6 V	-3.0	-	3.0	μA	
I_{OFF}	Power-Off Leakage Current of SENSE	Sense = 0 V to 1.0 V	Power off	-2.0	-	2.0	μA
	Power-Off Leakage Current of GSBUx	GSBUx = 0 V to 3.6 V		-3.0	-	3.0	μA

FSA4480

Table 4. DC ELECTRICAL CHARACTERISTICS (continued)

($V_{CC} = 2.7\text{ V to }5.5\text{ V}$, $V_{CC} (\text{Typ.}) = 3.3\text{ V}$, $T_A = -40^\circ\text{C to }85^\circ\text{C}$, and $T_A (\text{Typ.}) = 25^\circ\text{C}$, unless otherwise specified.)

Symbol	Parameter	Condition	Power	Min.	Typ.	Max.	Unit
--------	-----------	-----------	-------	------	------	------	------

SENSE SWITCH

V_{OV_TRIP}	Input OVP Lockout on GSBUX	Rising edge	$V_{CC}: 2.7\text{ V to }5.5\text{ V}$	4.5	5	5.3	V
V_{OV_HYS}	Input OVP Hysteresis of GSBUX			-	0.3	-	V

SBUX PINS

I_{OZ}	Off Leakage Current of SBUX	$SBUX = 0\text{ V to }3.6\text{ V}$	$V_{CC}: 2.7\text{ V to }5.5\text{ V}$	-3.0	-	3.0	μA
I_{OFF}	Power-Off Leakage Current Port SBUX	$SBUX = 0\text{ V to }3.6\text{ V}$	Power off	-3.0	-	3.0	μA
V_{OV_TRIP}	Input OVP Lockout	Rising edge	$V_{CC}: 2.7\text{ V to }5.5\text{ V}$	4.5	5	5.3	V
V_{OV_HYS}	Input OVP Hysteresis			-	0.3	-	V

MIC SWITCH

I_{ON}	On Leakage Current of MIC Switch	$SBUX = 0\text{ V to }3.6\text{ V}$, MIC is floating	$V_{CC}: 2.7\text{ V to }5.5\text{ V}$	-3.0	-	3.0	μA
I_{OZ}	Off Leakage Current of MIC	$MIC = 0\text{ V to }3.6\text{ V}$		-1.0	-	1.0	μA
I_{OFF}	Power Off Leakage Current of MIC	$MIC = 0\text{ V to }3.6\text{ V}$	Power off	-1.0	-	1.0	μA
R_{ON_MIC}	MIC Switch On Resistance	$I_{sw} = 30\text{ mA}$, $V_{sw} = 3.6\text{ V}$	$V_{CC}: 2.7\text{ V to }5.5\text{ V}$	1.7	3.0	3.9	Ω

SBUX_H SWITCH

I_{ON}	On Leakage Current of SBUX_H Switch	$SBUX = 0\text{ V to }3.6\text{ V}$, $SBUX_H$ is floating	$V_{CC}: 2.7\text{ V to }5.5\text{ V}$	-3.0	-	3.0	μA
I_{OZ}	Off Leakage of SBUX_H	$SBUX_H = 0\text{ V to }3.6\text{ V}$		-1	-	1	μA
I_{OFF}	Power Off Leakage Current of SBUX_H	$SBUX_H = 0\text{ V to }3.6\text{ V}$	Power off	-1.0	-	1.0	μA
R_{ON_SBU}	SBUX_H Switch On Resistance	$I_{sw} = 30\text{ mA}$, $V_{SW} = 0\text{ V to }3.6\text{ V}$	$V_{CC}: 2.7\text{ V to }5.5\text{ V}$	1.5	3.0	3.5	Ω

AUDIO GROUND SWITCH: PIN: AGND TO SBUX

R_{ON_AGND}	AGND Switch On Resistance	$I_{SOURCE} = 100\text{ mA}$ on SBUX	$V_{CC}: 2.7\text{ V to }5.5\text{ V}$	30	50	90	m Ω
----------------	---------------------------	--------------------------------------	--	----	----	----	------------

CC_IN PIN

V_{TH_L}	Input Low Threshold		$V_{CC}: 2.7\text{ V to }5.5\text{ V}$	-	1.2	-	V
V_{TH_H}	Input High Threshold			-	1.5	-	V
I_{IN}	Input Leakage of CC_IN	$CC_IN = 0\text{ V to }5.5\text{ V}$		-	-	1.0	μA

INT, DET PINS

V_{OH}	Output High for DET	$I_o = -2\text{ mA}$	$V_{CC}: 2.7\text{ V to }5.5\text{ V}$	1.5	1.8	2	V
V_{OL}	Output Low for DET and INT	$I_o = 2\text{ mA}$		-	-	0.4	V

FSA4480

Table 4. DC ELECTRICAL CHARACTERISTICS (continued)

($V_{CC} = 2.7\text{ V to }5.5\text{ V}$, $V_{CC} (\text{Typ.}) = 3.3\text{ V}$, $T_A = -40^\circ\text{C to }85^\circ\text{C}$, and $T_A (\text{Typ.}) = 25^\circ\text{C}$, unless otherwise specified.)

Symbol	Parameter	Condition	Power	Min.	Typ.	Max.	Unit
ADDR PIN							
V_{IH}	Input voltage High		$V_{CC}: 2.7\text{ V to }5.5\text{ V}$	1.3	-	-	V
V_{IL}	Input voltage Low			-	-	0.45	V
I_{IN}	Control Input Leakage	ADDR = 0 V to V_{CC}		-1	-	1	μA

ENN PIN

V_{IH}	Input Voltage High		$V_{CC}: 2.7\text{ V to }5.5\text{ V}$	1.3	-	-	V
V_{IL}	Input Voltage Low			-	-	0.45	V
R_{PD}	Internal Pull Down Resistor			-	470	-	$\text{k}\Omega$

SDS, SCL PINS

V_{ILi2C}	Low-Level Input Voltage		$V_{CC}: 2.7\text{ V to }5.5\text{ V}$	-	-	0.4	V
V_{IHl2C}	High-Level Input Voltage			1.2	-	-	V
I_{l2C}	Input Current of SDA and SCL Pins	SCL/SDA = 0 V to 3.6 V		-2	-	2	μA
V_{OLSDA}	Low-Level Output Voltage	$I_{OL} = 2\text{ mA}$		-	-	0.3	V
I_{OLSDA}	Low-Level Output Current	$V_{OLSDA} = 0.2\text{ V}$		10	-	-	mA

Product parametric performance is indicated in the Electrical Characteristics for the listed test conditions, unless otherwise noted. Product performance may not be indicated by the Electrical Characteristics if operated under different conditions.

FSA4480

Table 5. AC ELECTRICAL CHARACTERISTICS

($V_{CC} = 2.7\text{ V to }5.5\text{ V}$, $V_{CC} (\text{Typ.}) = 3.3\text{ V}$, $T_A = -40^\circ\text{C to }85^\circ\text{C}$, and $T_A (\text{Typ.}) = 25^\circ\text{C}$, unless otherwise specified.)

Symbol	Parameter	Condition	Power	Min.	Typ.	Max.	Unit	
AUDIO SWITCH								
t_{delay}	Audio Switch Turn On Delay Time	DP_R = DN_L = 1 V, $R_L = 32\ \Omega$	$V_{CC} = 3.3\text{ V}$	-	65	-	μs	
t_{rise}	Audio Switch Turn On Rising Time (Note 1)	DP_R = DN_L = 1 V, $R_L = 32\ \Omega$		-	240	-	μs	
t_{OFF}	Audio Switch Turn Off Time	DP_R = DN_L = 1 V, $R_L = 32\ \Omega$		-	15	-	μs	
X_{TALK}	Cross Talk (Adjacent)	$f = 1\text{ kHz}$, $R_L = 50\ \Omega$, $V_{\text{SW}} = 1\text{ V}_{\text{RMS}}$		-	-100	-	dB	
BW	-3 dB Bandwidth	$R_L = 50\ \Omega$		-	600	-	MHz	
O_{IRR}	Off Isolation	$F = 1\text{ kHz}$, $R_L = 50\ \Omega$, $C_L = 0\text{ pF}$, $V_{\text{SW}} = 1\text{ V}_{\text{RMS}}$		-	-100	-	dB	
THD+N	Total Harmonic Distortion + Noise Performance with A-weighting Filter	$R_L = 600\ \Omega$, $f = 20\text{ Hz} \sim 20\text{ kHz}$, $V_{\text{SW}} = 2\text{ V}_{\text{RMS}}$		-	-110	-	dB	
		$R_L = 32\ \Omega$, $f = 20\text{ Hz} \sim 20\text{ kHz}$, $V_{\text{SW}} = 1\text{ V}_{\text{RMS}}$		-	-110	-	dB	
		$R_L = 16\ \Omega$, $f = 20\text{ Hz} \sim 20\text{ kHz}$, $V_{\text{SW}} = 0.5\text{ V}_{\text{RMS}}$		-	-108	-	dB	
USB SWITCH								
t_{ON}	USB Switch Turn-on Time	DP_R = DN_L = 1.5 V, $R_L = 50\ \Omega$	$V_{CC} = 3.3\text{ V}$	-	60	-	μs	
t_{OFF}	USB Switch Turn-off Time	DP_R = DN_L = 1.5 V, $R_L = 50\ \Omega$		-	15	-	μs	
BW	-3 dB Bandwidth	$R_L = 50\ \Omega$		-	850	-	MHz	
	SDD ₂₁ -3 dB Bandwidth			-	950	-		
O_{IRR}	Off Isolation between DP, DN and Common Node Pins	$f = 1\text{ kHz}$, $R_L = 50\ \Omega$, $C_L = 0\text{ pF}$, $V_{\text{SW}} = 1\text{ V}_{\text{RMS}}$		-	-100	-	dB	
t_{OVP}	DP_R and DN_L pins OVP Response Time	$V_{\text{sw}} = 3.5\text{ V to }5.5\text{ V}$		-	1	1.5	μs	
MIC/AUDIO GROUND SWITCH								
$t_{\text{delay_MIC}}$	MIC Switch Turn On Delay Time	SBUx = 1 V, $R_L = 50\ \Omega$	$V_{CC} = 3.3\text{ V}$	-	100	-	μs	
$t_{\text{rise_MIC}}$	MIC Switch Turn On Rising Time (Note 1)			-	250	-		
$t_{\text{delay_AGND}}$	AGND Switch Turn On Time	SBUx pulled up to 0.5 V by 16 Ω , AGND connect to GND	$V_{CC} = 3.3\text{ V}$	-	100	-	μs	
$t_{\text{rise_AGND}}$	AGND Switch Turn On Rising Time (Note 1)			-	1500	-		
$t_{\text{OFF_MIC}}$	MIC Switch Turn Off Time	SBUx = 2.5 V, $R_L = 50\ \Omega$		-	15	-		
$t_{\text{OFF_Audio GND}}$	AGND Switch Turn Off Time	SBUx: Isource = 10 mA, clamp to 2.5 V		-	15	-		
BW	MIC Switch Bandwidth	$R_L = 50\ \Omega$		-	50	-		MHz

FSA4480

Table 5. AC ELECTRICAL CHARACTERISTICS (continued)

($V_{CC} = 2.7\text{ V to }5.5\text{ V}$, $V_{CC} (\text{Typ.}) = 3.3\text{ V}$, $T_A = -40^\circ\text{C to }85^\circ\text{C}$, and $T_A (\text{Typ.}) = 25^\circ\text{C}$, unless otherwise specified.)

Symbol	Parameter	Condition	Power	Min.	Typ.	Max.	Unit
--------	-----------	-----------	-------	------	------	------	------

SBUX_H SWITCH

t_{ON}	SBUX_H Switch Turn On Time	$SBUX = 2.5\text{ V}$, $R_L = 50\ \Omega$	$V_{CC} = 3.3\text{ V}$	-	35	-	μs
t_{OFF}	SBUX_H Switch Turn Off Time			-	15	-	
BW	Bandwidth	$R_L = 50\ \Omega$		-	50	-	MHz
t_{OVP}	SBUX Pins OVP Response Time	$V_{sw} = 3.5\text{ V to }5.5\text{ V}$		-	0.5	1	μs

SENSE SWITCH

t_{delay}	Sense Switch Turn On Delay Time	$GSBUX = 1\text{ V}$, $R_L = 50\ \Omega$	$V_{CC} = 3.3\text{ V}$	-	65	-	μs
t_{rise}	Sense Switch Turn On Rising Time (Note 1)			-	260	-	μs
t_{OFF}	Sense Switch Turn Off Time			-	15	-	μs
t_{OVP}	GSBUX Pins OVP Response Time	$V_{SW}: 3.5\text{ V to }5.5\text{ V}$		-	0.7	1.5	μs
BW	Bandwidth	$R_L = 50\ \Omega$		-	150	-	MHz

DET DELAY

t_{DELAY_DET}	DET Response Delay	Transition from 0 to 1.8 V	$V_{CC} = 3.3\text{ V}$	-	1	-	μs
		Transition from 1.8 to 0 V		-	5	-	

1. Turn on timing can be controlled by I²C register.

Table 6. I²C SPECIFICATION

(V_{CC} = 2.7 V to 5.5, V_{CC} (Typ.) = 3.3 V, T_A = -40°C to 85°C. T_A (Typ.) = 25°C, unless otherwise specified)

Symbol	Parameter	Fast Mode		
		Min.	Max.	Unit
f _{SCL}	I ² C_SCL Clock Frequency		400	kHz
t _{HD; STA}	Hold Time (Repeated) START Condition	0.6		μs
t _{LOW}	Low Period of I ² C_SCL Clock	1.3		μs
t _{HIGH}	High Period of I ² C_SCL Clock	0.6		μs
t _{SU; STA}	Set-up Time for Repeated START Condition	0.6		μs
t _{HD; DAT}	Data Hold Time (Note 2)	0	0.9	μs
t _{SU; DAT}	Data Set-up Time (Note 3)	100		ns
t _r	Rise Time of I ² C_SDA and I ² C_SCL Signals (Note 3)	20 + 0.1C _b	300	ns
t _f	Fall Time of I ² C_SDA and I ² C_SCL Signals (Note 3)	20 + 0.1C _b	300	ns
t _{SU; STO}	Set-up Time for STOP Condition	0.6		μs
t _{BUF}	Bus-Free Time between STOP and START Conditions	1.3		μs
t _{SP}	Pulse Width of Spikes that Must Be Suppressed by the Input Filter	0	50	ns

2. Guaranteed by design, not production tested.
3. A fast-mode I²C-bus device can be used in a standard-mode I²C-bus system, but the requirement t_{SU;DAT} ≥ ±250 ns must be met. This is automatically the case if the device does not stretch the LOW period of the I²C_SCL signal. If such a device does stretch the LOW period of the I²C_SCL signal, it must output the next data bit to the I²C_SDA line t_{r_max} + t_{SU;DAT} = 1000 + 250 = 1250 ns (according to the standard-mode I²C bus specification) before the I²C_SCL line is released.

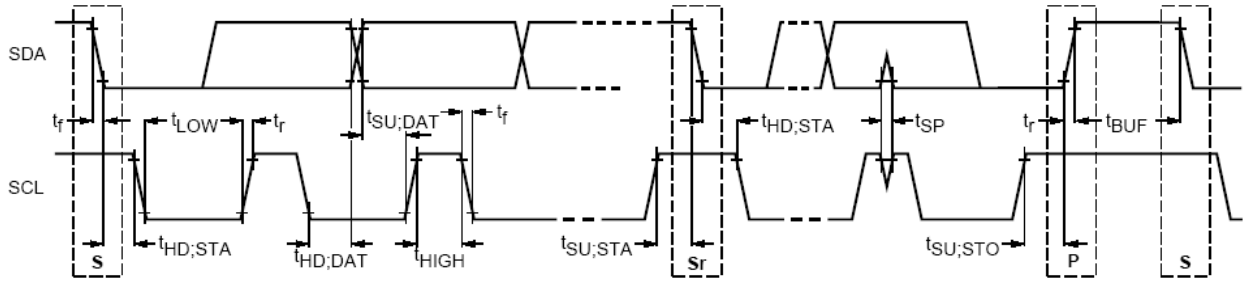

Figure 3. Definition of Timing for Full-Speed Mode Devices on the I²C Bus

FSA4480

Table 7. CAPACITANCE

(V_{CC} = 2.7 V to 5.5 V, V_{CC} (Typ.) = 3.3 V, T_A = -40°C to 85°C, and T_A (Typ.) = 25°C)

Symbol	Parameter	Condition	Power	T _A = -40°C to +85°C			Unit
				Min.	Typ.	Max.	
C _{CON_USB/Audio}	On Capacitance ⁽⁶⁾ (Common Port)	f = 1 MHz, 100 mV _{PK-PK} , 100 mV DC bias	VCC = 3.3 V		9		pF
C _{OFF_USB/Audio}	Off Capacitance ⁽⁶⁾ (Common Port)	f = 1 MHz, 100 mV _{PK-PK} , 100 mV DC bias			7.5		pF
C _{OFF_USB}	Off Capacitance (Non-Common Ports) ⁽⁶⁾	f = 1 MHz, 100 mV _{PK-PK} , 100 mV DC bias			3		pF
C _{CON_SENSE_SW}	On Capacitance – (Common Ports) ⁽⁶⁾	f = 1 MHz, 100 mV _{PK-PK} , 100 mV DC bias			55		pF
C _{OFF_SENSE_SW}	Off Capacitance – (Common Ports) ⁽⁶⁾	f = 1 MHz, 100 mV _{PK-PK} , 100 mV DC bias			88		pF
C _{CON_MIC_SW}	On Capacitance – (Common Ports) ⁽⁶⁾	f = 1 MHz, 100 mV _{PK-PK} , 100 mV DC bias			170		pF
C _{OFF_MIC_SW}	Off Capacitance – (Common Ports) ⁽⁶⁾	f = 1 MHz, 100 mV _{PK-PK} , 100 mV DC bias			10		pF
C _{CON_AGND_SW}	On Capacitance ⁽⁶⁾ (Common Port)	f = 1 MHz, 100 mV _{PK-PK} , 100 mV DC bias			125		pF
C _{CON_SBUx_H_SW}	On Capacitance ⁽⁶⁾ (Common Port)	f = 1 MHz, 100 mV _{PK-PK} , 100 mV DC bias			160		pF
C _{CNTRL}	Control Input Pin Capacitance ⁽⁶⁾	f = 1 MHz, 100 mV _{PP} , 100 mV DC bias	ENN		3		pF

Table 8. REGISTER MAPS

ADDR	Register Name	Type	Reset Value	BIT7	BIT6	BIT5	BIT4	BIT3	BIT2	BIT1	BIT0
00H	Device ID	R	0x09	0	0	0	0	1	0	0	1
01H	OVP Interrupt Mask	R/W	0x00	Reserved	Mask OVP interrupt	Mask OVP /DP_R	Mask OVP /DN_L	Mask OVP /SBU1	Mask OVP /SBU2	Mask OVP /GSBU1	Mask OVP /GSBU2
02H	OVP interrupt flag	R/C	0x00	Reserved		DP_R	DN_L	SBU1	SBU2	GSBU	GSBU2
03H	OVP status	R	0x00	Reserved		OVP/DP_R	OVP/DN_L	OVP/SBU1	OVP/SBU2	OVP/GSBU1	OVP/GSBU2
04H	Switch settings Enable	R/W	0x98	Device control	SBU1_H to SBUx	SBU2_H to SBUx	DN_L to DN or L	DP_R to DP or R	Sense to GSBUX	MIC to SBUx	Audio Ground to SBUx
05H	Switch select	R/W	0x18	Reserved	SBU1_H to SBUx	SBU2_H to SBUx	DN_L to DN or L	DP_R to DP or R	Sense to GSBUX	MIC to SBUx	Audio Ground to SBUx
06H	Switch Status0	R	0x00	Reserved		Sense Switch Status		DP_R Switch Status		DN_L Switch Status	
07H	Switch Status1	R	0x00	Reserved		SBU2 Switch Status			SBU1 Switch Status		
08H	Audio Switch Left Channel turn on Control	R/W	0x01	Audio switch left channel slow control [7:0]							
09H	Audio Switch Right Channel turn on Control	R/W	0x01	Audio switch right channel slow control [7:0]							
0AH	MIC switch turn on control	R/W	0x01	MIC switch right channel slow control [7:0]							
0BH	Sense switch turn on control	R/W	0x01	Sense switch right channel slow control [7:0]							
0CH	Audio Ground Switch turn on Control	R/W	0x01	Audio ground switch right channel slow control [7:0]							

FSA4480

Table 8. REGISTER MAPS

ADDR	Register Name	Type	Reset Value	BIT7	BIT6	BIT5	BIT4	BIT3	BIT2	BIT1	BIT0	
0DH	Timing Delay between R switch enable and L switch enable	R/W	0x00	Timing Delay between R switch enable and L switch enable control [7:0]								
0EH	Timing Delay between MIC switch enable and L switch enable	R/W	0x00	Timing Delay between MIC switch enable and L switch enable control [7:0]								
0FH	Timing Delay between Sense switch enable and L switch enable	R/W	0x00	Timing Delay between Sense switch enable and L switch enable control [7:0]								
10H	Timing Delay between Audio ground switch enable and L switch enable	R/W	0x00	Timing Delay between Audio ground switch enable and L switch enable control [7:0]								
11H	Audio accessory status	R	0x02	Reserved						CC_IN	DET	
12H	Function enable	R/W	0x08	Reserved	DET I/O Control	RES detection range setting	GIPO control	SLOW TURN-ON CONTROL	MIC auto control	RES detection : auto clear	Audio jack detection : auto clear	
13H	RES detection pin setting	R/W	0x00	Reserved					Detection pin select [2:0]			
14H	RES detection value	R	0xFF	R detection value [7:0]								
15H	RES detection interrupt threshold	R/W	0x16	R detection Interrupt resistance threshold [7:0]								
16H	RES detection interval	R/W	0X00	Reserved						Detection interval [1:0]		
17H	Audio jack Status	RO	0x01	Reserved				4pole,SB U2 MIC	4pole,SB U1 MIC	3pole	No audio	
18H	Detection interrupt	R/C	0x00	Reserved					Audio detection done	RES detection occurred	RES detection done	
19H	Detection interrupt Mask	R/W	0x00	Reserved					Audio detection done mask	RES detection occurred mask	RES detection done mask	
1AH	Audio detection RGE1	RO	0xFF	audio detection value REG1 [7:0]								
1BH	Audio detection RGE2	RO	0xFF	audio detection value REG2 [7:0]								
1CH	MIC Threshold DATA0	R/W	0x20	MIC Threshold value DATA0 [7:0]								
1DH	MIC Threshold DATA1	R/W	0xFF	MIC Threshold value DATA1 [7:0]								
1EH	I2C Reset	W/C	0x00	Reserved								I2C reset
1FH	Current Source Setting	R/W	0x07	Reserved				Current Source setting [3:0]				

Table 9. I²C SLAVE ADDRESS

ADDR	Bit 7	Bit 6	Bit 5	Bit 4	Bit 3	Bit 2	Bit 1	Bit 0
ADDR = L	1	0	0	0	0	1	0	R/W
ADDR = H	1	0	0	0	0	1	1	R/W

FSA4480

DEVICE ID

Address: 00h

Reset Value: 8'b 0000_1001

Type: Read

Bits	Name	Size	Description
7:6	Vendor ID	2	Vendor ID
5:3	Version ID	3	Device Version ID
2:0	Revision ID	3	Revision History ID

OVP INTERRUPT MASK

Address: 01h

Reset Value: 8'b 0000_0000

Type: Read/Write

Bits	Name	Size	Description
7	Reserved	1	Do Not Use
6	OVP Interrupt mask control	1	OVP Interrupt function Enable/Disable 0: Controlled by [5:0] bit 1: Mask all connector side pins OVP interrupt
5	DP_R OVP Interrupt mask control	1	0: Do not mask OVP interrupt 1: Mask OVP interrupt
4	DN_L OVP Interrupt mask control	1	0: Do not mask OVP interrupt 1: Mask OVP interrupt
3	SBU1 OVP Interrupt mask control	1	0: Do not mask OVP interrupt 1: Mask OVP interrupt
2	SBU2 OVP Interrupt mask control	1	0: Do not mask OVP interrupt 1: Mask OVP interrupt
1	GSBU1 OVP Interrupt mask control	1	0: Do not mask OVP interrupt 1: Mask OVP interrupt
0	GSBU2 OVP Interrupt mask control	1	0: Do not mask OVP interrupt 1: Mask OVP interrupt

OVP INTERRUPT FLAG

Address: 02h

Reset Value: 8'b 0000_0000

Type: Read Clear

Bits	Name	Size	Description
[7:6]	Reserved	2	Do Not Use
5	DP_R OVP	1	0: OVP event has not occurred 1: OVP event has occurred
4	DN_L OVP	1	0: OVP event has not occurred 1: OVP event has occurred
3	SBU1 OVP	1	0: OVP event has not occurred 1: OVP event has occurred
2	SBU2 OVP	1	0: OVP event has not occurred 1: OVP event has occurred
1	GSBU1 OVP	1	0: OVP event has not occurred 1: OVP event has occurred
0	GSBU2 OVP	1	0: OVP event has not occurred 1: OVP event has occurred

FSA4480

OVP STATUS

Address: 03h

Reset Value: 8'b 0000_0000

Type: Read

Bits	Name	Size	Description
[7:6]	Reserved	2	Do Not Use
5	OVP on DP_R PIN	1	0: OVP event has not occurred 1: OVP event has occurred
4	OVP on DN_L PIN	1	0: OVP event has not occurred 1: OVP event has occurred
3	OVP on SBU1 PIN	1	0: OVP event has not occurred 1: OVP event has occurred
2	OVP on SBU2 PIN	1	0: OVP event has not occurred 1: OVP event has occurred
1	OVP on GSBU1 PIN	1	0: OVP event has not occurred 1: OVP event has occurred
0	OVP on GSBU2 PIN	1	0: OVP event has not occurred 1: OVP event has occurred

SWITCHING SETTING ENABLE

Address: 04h

Reset Value: 8'b 1001_1000

Type: Read/Write

Bits	Name	Size	Description
7	Device Enable	1	0: Device Disable; L, R pull down by 10 k and other switch nodes will be high-Z for positive input. 1: Device Enable. Device Enable = 1 Device enable = 0 ENN = 1 Device Disable Device Disable ENN = 0 Device Enable Device Disable
6	SBU1_H to SBUx switches	1	0: Switch Disable; SBU1_H will be high-Z for positive input 1: Switch Enable
5	SBU2_H to SBUx switches	1	0: Switch Disable; SBU2_H will be high-Z for positive input 1: Switch Enable
4	DN_L to DN or L switches	1	0: Switch Disable; DN_L, DN will be high-Z for positive input. L pull down by 10 kohm 1: Switch Enable
3	DP_R to DP or R switches	1	0: Switch Disable; DP_R, DP will be high-Z for positive input. R pull down by 10 kohm 1: Switch Enable
2	Sense to GSBUX switches	1	0: Switch Disable; Sense, GSBU1 and GSBU2 will be high-Z for positive input 1: Switch Enable
1	MIC to SBUx switches	1	0: Switch Disable: MIC will be high-Z for positive input. 1: Switch Enable
0	AGND to SBUx switches	1	0: Switch Disable: AGND will be high-Z for positive input. 1: Switch Enable

FSA4480

SWITCH SELECT

Address: 05h

Reset Value: 8'b 0001_1000

Type: Read/Write

Bits	Name	Size	Description
7	Reserved	1	Do Not Use
6	SBU1_H switches	1	0: SBU1_H to SBU1 switch ON 1: SBU1_H to SBU2 switch ON
5	SBU2_H switches	1	0: SBU2_H to SBU2 switch ON 1: SBU2_H to SBU1 switch ON
4	DN_L to DN or L switches	1	0: DN_L to L switch ON 1: DN_L to DN switch ON
3	DP_R to DP or R switches	1	0: DP_R to R switch ON 1: DP_R to DP switch ON
2	Sense to GSBUX switches	1	0: Sense to GSBU1 switch ON 1: Sense to GSBU2 switch ON
1	MIC to SBUx switches	1	0: MIC to SBU2 switch ON 1: MIC to SBU1 switch ON
0	AGND to SBUx switches	1	0: AGND to SBU1 switch ON 1: AGND to SBU2 switch ON

SWITCH STATUS0

Address: 06h

Reset Value: 8'b 0000_0000

Type: Read Only

Bits	Name	Size	Description
[7:6]	Reserved	2	Do not use
[5:2]	Sense Switch Status	2	00: Sense switch is Open/Not Connected 01: Sense connected to GSBU1 10: Sense connected to GSBU2 11: Not Valid
[3:2]	DP_RSwitch Status	2	00: DP_R Switch Open/Not Connected 01: DP_Rconnected to DP 10: DP_Rconnected to R 11: Not Valid
[1:0]	DN_L switch Status	2	00: DN_L Switch Open/Not Connected 01: DN_L connected to DN 10: DN_L connected to L 11: Not Valid

FSA4480

SWITCH STATUS1

Address: 07h

Reset Value: 8'b 0000_0000

Type: Read Only

Bits	Name	Size	Description
[7:6]	Reserved	2	Do not use
[5:3]	SBU2 Switch Status	3	000: SBU2 switch is Open/Not Connected 001: SBU2 connected to MIC 010: SBU2 connected to AGND 011: SBU2 connected to SBU1_H 100: SBU2 connected to SBU2_H 101: SBU2 connected both SBU1_H and SBU2_H 110...111: Do not use
[2:0]	SBU1 Switch Status	3	000: SBU1 switch is Open/Not Connected 001: SBU1 connected to MIC 010: SBU1 connected to AGND 011: SBU1 connected to SBU1_H 100: SBU1 connected to SBU2_H 101: SBU1 connected both SBU1_H and SBU2_H 110...111: Do not use

AUDIO SWITCH LEFT CHANNEL SLOW TURN-ON

Address: 08h

Reset Value: 8'b 0000_0001

Type: Read/Write

Bits	Name	Size	Description
[7:0]	Switch turn on rising time setting	8	11111111: 25600 μ S
			...
			00000001: 200 μ S
			00000000: 100 μ S

AUDIO SWITCH RIGHT CHANNEL SLOW TURN-ON

Address: 09h

Reset Value: 8'b 0000_0001

Type: Read/Write

Bits	Name	Size	Description
[7:0]	Switch turn on rising time setting	8	11111111: 25600 μ S
			...
			00000001: 200 μ S
			00000000: 100 μ S

MIC SWITCH SLOW TURN-ON

Address: 0Ah

Reset Value: 8'b 0000_0001

Type: Read/Write

Bits	Name	Size	Description
[7:0]	Switch turn on rising time setting	8	11111111: 25700 μ S
			...
			00000010: 350 μ S
			00000001: 250 μ S
			00000000: Not Valid

FSA4480

SENSE SWITCH SLOW TURN-ON

Address: 0Bh

Reset Value: 8'b 0000_0001

Type: Read/Write

Bits	Name	Size	Description
[7:0]	Switch turn on rising time setting	8	11111111: 25600 μ S
			...
			00000001: 200 μ S
			00000000: 100 μ S

AUDIO GROUND SWITCH SLOW TURN-ON

Address: 0Ch

Reset Value: 8'b 0000_0001

Type: Read/Write

Bits	Name	Size	Description
[7:0]	Switch turn on rising time setting	8	11111111: 179000 μ S
			...
			00000001: 1400 μ S
			00000000: 700 μ S

TIMING DELAY BETWEEN R SWITCH ENABLE AND L SWITCH ENABLE

Address: 0Dh

Reset Value: 8'b 0000_0000

Type: Read/Write

Bits	Name	Size	Description
[7:0]	Delay timing setting	8	11111111: 25500 μ S
			11111110: 25400 μ S
			...
			00000001: 100 μ S
			00000000: 0 μ S

TIMING DELAY BETWEEN MIC SWITCH ENABLE AND L SWITCH ENABLE

Address: 0Eh

Reset Value: 8'b 0000_0000

Type: Read/Write

Bits	Name	Size	Description
[7:0]	Delay timing setting	8	11111111: 25500 μ S
			11111110: 25400 μ S
			...
			00000001: 100 μ S
			00000000: 0 μ S

FSA4480

TIMING DELAY BETWEEN SENSE SWITCH ENABLE AND L SWITCH ENABLE

Address: 0Fh

Reset Value: 8'b 0000_0000

Type: Read/Write

Bits	Name	Size	Description
[7:0]	Delay timing setting	8	11111111: 25500 μ S
			11111110: 25400 μ S
			...
			00000001: 100 μ S
			00000000: 0 μ S

TIMING DELAY BETWEEN AUDIO GROUND SWITCH ENABLE AND L SWITCH ENABLE

Address: 10h

Reset Value: 8'b 0000_0000

Type: Read/Write

Bits	Name	Size	Description
[7:0]	Delay timing setting	8	11111111: 25500 μ S
			11111110: 25400 μ S
			...
			00000001: 100 μ S
			00000000: 0 μ S

AUDIO ACCESSORY STATUS

Address: 11h

Reset Value: 8'b 0000_0010

Type: Read

Bits	Name	Size	Description
[7:2]	Reserved	6	Do not use
1	CC_IN	1	0: CC_IN < 1.2 V 1: CC_IN > 1.5 V
0	DET	1	0: DET output is low 1: DET is output is high

FSA4480

FUNCTION ENABLE

Address: 12h

Reset Value: 8'b 0000_1000

Type: Read/Write

Bits	Name	Size	Description
7	Reserved	1	Do not use
6	DET I/O Control	1	1: DET pin is in Open/Drain Configuration 0: DET pin is in Push/Pull Configuration
5	RES detection range setting	1	1: 10k to 2560 k 0: 1k to 256 k
4	GPIO control enable	1	1: enable 0: disable
3	Slow turn on control enable	1	1: enable 0: disable
2	MIC auto break out control enable	1	1: enable 0: disable
1	RES detection enable	1	1: enable; will be changed to '0' after low resistance detection 0: disable
0	Audio jack detection and configuration enable	1	1: enable; will be changed to '0' after audio jack detection and configuration 0: disable

When GPIO control mode (manual switch control) is enable. '**Switch control**' register is changed to read only. It will reflect switch status. I²C slave address is

RES DETECTION PIN SETTING

Address: 13h

Reset Value: 8'b 0000_0000

Type: Read

Bits	Name	Size	Description
[7:3]	Reserved	5	Do not use
[2:0]	Pin selection	3	000: CC_IN 001: DP/R 010: DN_L 011: SBU1 100: SBU2 101: Do not use ... 111: Do not use

If RES detection pin is enable before setting PIN selection it will always do the CC_IN first. Recommend user to select the pin first before setting the RES detection pin enable.

RES VALUE

Address: 14h

Reset Value: 8'b 1111_1111

Type: Read

Bits	Name	Size	Description
[7:0]	Detected resistance value	8	0000_0000 : R < 1 k ... 1111_1111: R > 300 K

FSA4480

RES DETECTION THRESHOLD

Address: 15h

Reset Value: 8'b 0001_0110

Type: Read

Bits	Name	Size	Description
[7:0]	RES detection threshold	8	Selection by 1 K Ω per step if Reg 12h [5] = 0 Selection by 10 K Ω per step if Reg 12h [5] = 0 Default Value = 22 K Ω 0000_0000: 1 K Ω /10 K Ω ... 1111_1111: 256 K Ω / 2560 K Ω

RES DETECTION INTERVAL

Address: 16h

Reset Value: 8'b 0000_0000

Type: Read

Bits	Name	Size	Description
[7:2]	Reserved	6	Do not use
[1:0]	RES detection interval	2	00: Single 01: 100 mS 10: 1 S 11: 10 S

AUDIO JACK STATUS

Address: 17h

Reset Value: 8'b 0000_0001

Type: Read

Bits	Name	Size	Description
[7:3]	Reserved	4	Do not use
3	4pole	1	1: 4 Pole SBU2 to MIC, SBU1 to audio ground 0: others
2	4pole	1	1: 4 Pole SBU1 to MIC, SBU2 to audio ground 0: others
1	3 pole	1	1: 3 pole 0: others
0	No audio accessory	1	1: No audio accessory 0: Audio accessory attached

RES DETECTION /AUDIO JACK DETECTION INTERRUPT FLAG

Address: 18h

Reset Value: 8'b 0000_0000

Type: Read Clear

Bits	Name	Size	Description
[7:3]	Reserved	5	Do Not Use
2	Audio jack detection and configuration	1	0: Audio jack detection and configuration has not occurred 1: Audio jack detection and configuration has occurred
1	Low resistance occurred	1	0: Low resistance has not occurred 1: Low resistance has occurred
0	Low resistance detection	1	0: Low resistance has not occurred 1: Low resistance has occurred

FSA4480

RES /AUDIO JACK DETECTION INTERRUPT MASK

Address: 19h

Reset Value: 8'b 0000_0000

Type: Read Clear

Bits	Name	Size	Description
[7:3]	Reserved	5	Do Not Use
2	Audio jack detection and configuration	1	1: Mask Audio jack detection and configuration has occurred interrupt
1	Low resistance occurred	1	1: Low resistance has occurred interrupt
0	Low resistance detection	1	1: Low resistance detection has occurred interrupt

AUDIO JACK DETECTION REG1 VALUE

Address: 1Ah

Reset Value: 8'b 1111_1111

Type: Read

Bits	Name	Size	Description
[7:0]	Audio jack detection value	8	Resistance between SBU1 to SBU2

AUDIO JACK DETECTION REG2 VALUE

Address: 1Bh

Reset Value: 8'b 1111_1111

Type: Read

Bits	Name	Size	Description
[7:0]	Audio jack detection value	8	Resistance between SBU2 to SBU1

MIC DETECTION THRESHOLD DATA0

Address: 1Ch

Reset Value: 8'b 0010_0000

Type: Read/Write

Bits	Name	Size	Description
[7:0]	MIC detection threshold DATA0	8	MIC detection threshold DATA0 0010_0000: 300 mV

MIC DETECTION THRESHOLD DATA1

Address: 1Dh

Reset Value: 8'b 1111_1111

Type: Read/Write

Bits	Name	Size	Description
[7:0]	MIC detection threshold DATA1	8	MIC detection threshold DATA1 1111_1111: 2.4 V

I2C RESET

Address: 1Eh

Reset Value: 8'b 0000_0000

Type: W/C

Bits	Name	Size	Description
[7:1]	Reserved	7	Reserved
0	I2C reset	1	0: default 1: I2C reset

FSA4480

CURRENT SOURCE SETTING

Address: 1Fh

Reset Value: 8'b 0000_0111

Type: Write

Bits	Name	Size	Description
[7:4]	Reserved	4	Reserved
[3:0]	Current Source Setting	4	1111: 1500 μ A 0111: 700 μ A 0001: 100 μ A 0000: invalid

APPLICATION INFORMATION

Over-Voltage Protection

FSA4480 features over-voltage protection (OVP) on receptacle side pins that switches off the internal signal routing path if the input voltage exceeds the OVP threshold.

If OVP is occurred, interrupt signal can be send by INT signal and FLAG data will provide information that which pin had OVP event.

Headset Detection

FSA4480 integrates headset unplug detection function by detecting the CC_IN voltage. The function is always active when device is enabling. DET will be high when CC_IN is low (CC_IN < 1.2 V). When CC_IN = High (CC_IN > 1.5 V), DET will be released to low.

	Device Disable	Device Enable
CC_IN < V _{TH_L} = 1.2 V	DET = 0	DET = 1
CC_IN > V _{TH_H} = 1.5 V	DET = 0	DET = 0

MIC Switch Auto-off Function

The function is active during control bit 0x12h bit[2] = 1. When CC_IN is high (CC_IN > 1.5 V) and L,R, Audio ground switches are under on status, MIC switch will be off and receptacle side pin will be connected to ground for 50 μS first. Then it shows high-Z status under MIC switch is set on status.

Audio Ground Detection and Configuration

The function is active when control bit 0x12h bit[0] = 1 and R, L AGND switches are set to be on status. For type-C interface analog headset, the audio ground could be SBU1 pin or SBU2 pin. The function will provide autonomous detection and configuration to route MIC and audio ground signal accordingly.

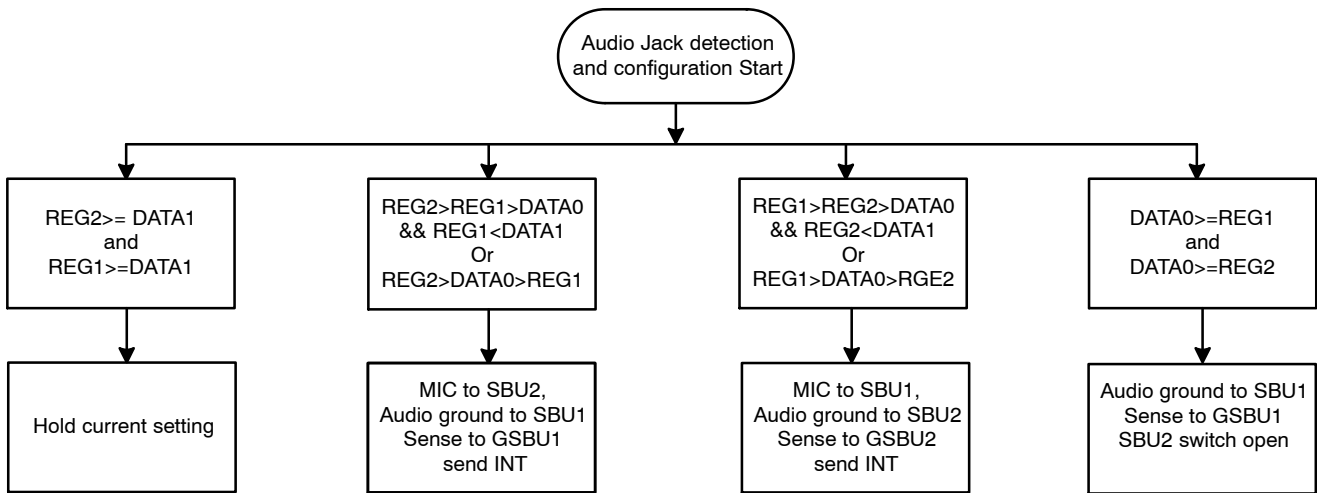

Figure 4.

During detection and configuration, the R, L, Sense, MIC and Audio ground switch will be off. After detection and configuration, R and L switches will turn on according to

switch configuration and timing setting. MIC, Sense and Audio ground will turn on according to detection results and timing control setting.

Resistance Detection

The function is active during control bit 0x12h bit[1] = 1. It will monitor the resistance between receptacle side pins and ground. During resistance detection, the switch which is monitored will be off. The detection result will be saved

in the resistance flag register. The measurement could be from 1 kΩ to 2.56 MΩ which is controlled by internal register. The detection interval can be set at 100 ms, 1 s or 10 s by register 0x16h.

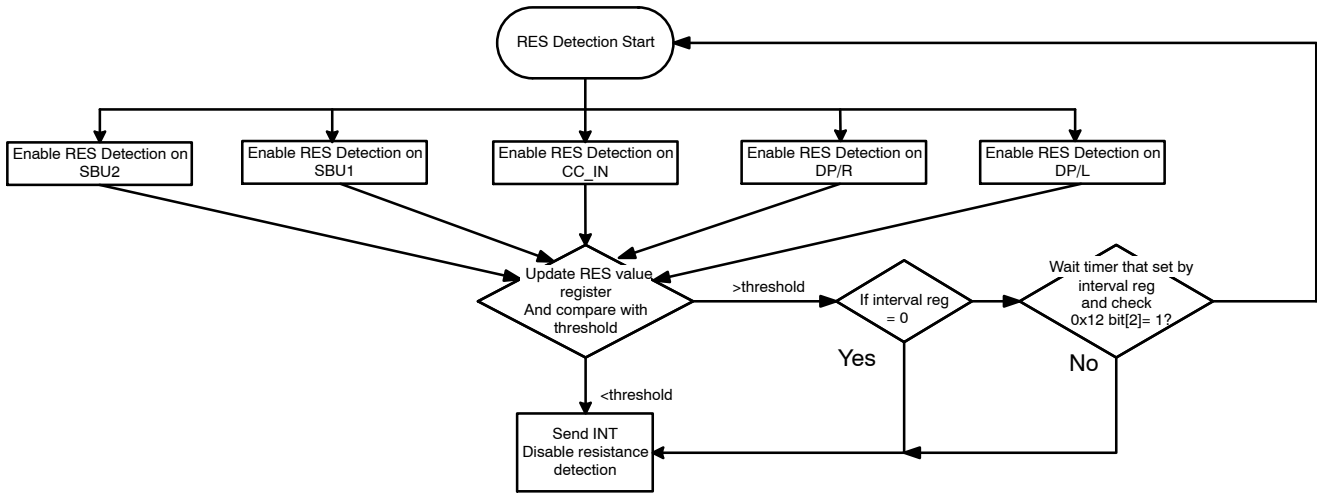

Figure 5.

Manual Switch Control

The function is active during control bit 0x12h bit[4] = 1 and 0x04h = FF. It will provide manual control for device.

During this configuration, ADDR and INT pins will be set as logic control input.

MANUAL SWITCH CONTROL

(The function is active during control bit 0x12h bit[4] = 1 and 0x04h = FF. It will provide manual control for device. During this configuration, ADDR and INT pins will be set as logic control input.)

Power	ENN	ADDR	INT	SENSE Switch	Headset Detection	USB Switch	Audio Switch	MIC/ Audio GND Switch	SBU by Pass Switch
OFF	X	X	X	OFF	OFF	OFF	OFF	OFF	OFF
ON	H	X	X	OFF	OFF	OFF	OFF	OFF	OFF
ON	L	0	0	OFF	OFF	ON: DP_R to DP DN_L to DN	OFF	OFF	ON: SBU1 to SBU1_H SBU2 to SBU2_H
ON	L	0	1	OFF	OFF	ON: DP_R to DP DN_L to DN	OFF	OFF	ON: SBU1 to SBU2_H SBU2 to SBU1_H
ON	L	1	0	ON GSBU2 to SESNE	ON	OFF	ON: DP_R to R DN_L to L	ON: SBU1 to MIC SBU2 to Audio GND	OFF
ON	L	1	1	ON GSBU1 to SESNE	ON	OFF	ON: DP_R to R DN_L to L	ON: SBU2 to MIC SBU1 to Audio GND	OFF

FSA4480

I²C INTERFACE

The FSA4480 includes a full I²C slave controller. The I²C slave fully complies with the I²C specification version 2.1

requirements. This block is designed for fast mode, 400 kHz, signals.

Examples of an I²C write and read sequence are shown in below figures respectively.

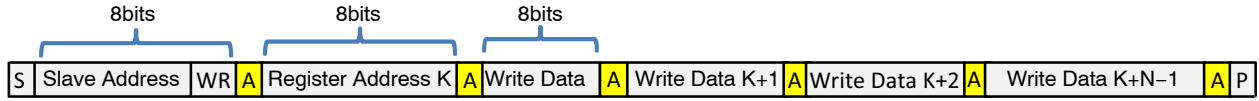

NOTE: Single Byte read is initiated by Master with P immediately following first data byte.

Figure 6. I²C Write Example

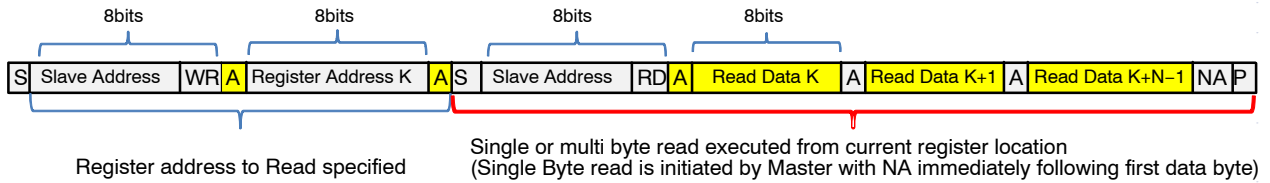

NOTE: If Register is not specified Master will begin read from current register. In this case only sequence showing in Red bracket is needed

	From Master to Slave	S	Start Condition	NA	NOT Acknowledge (SDA High)	RD	Read = 1
	From Slave to Master	A	Acknowledge (SDA Low)	WR	Write = 0	P	Stop Condition

Figure 7. I²C Read Example

TEST DIAGRAMS

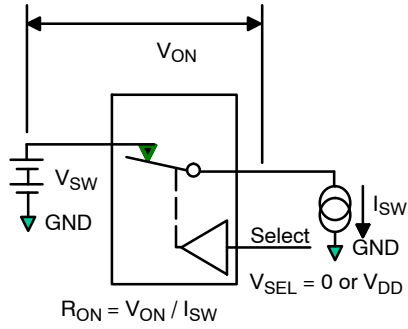
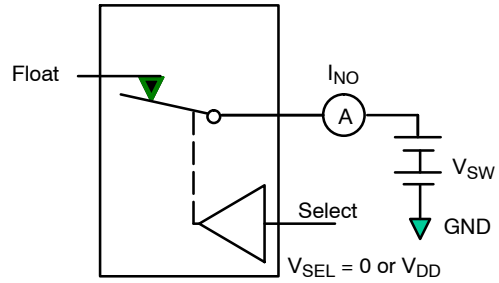

Figure 8. On Resistance



NOTE: Each switch port is tested separately.

Figure 9. Off Leakage (I_{oz})

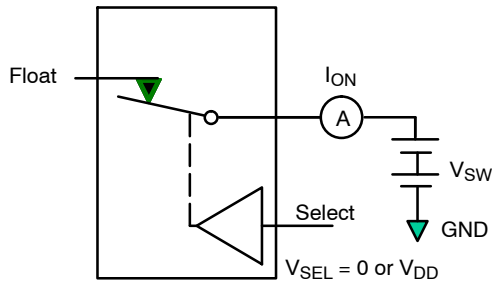
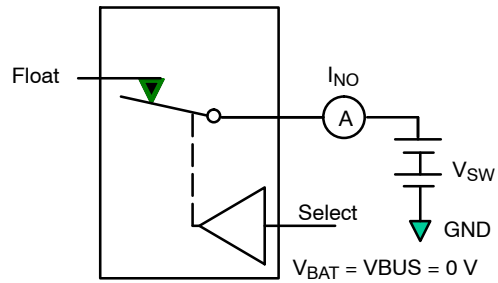

Figure 10. On Leakage



NOTE: Each switch port is tested separately.

Figure 11. Power Off Leakage (I_{off})

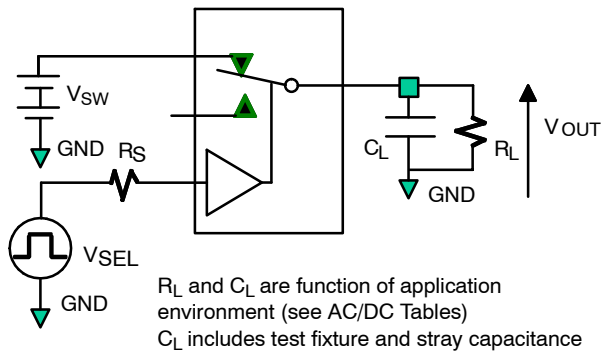

Figure 12. Test Circuit Load

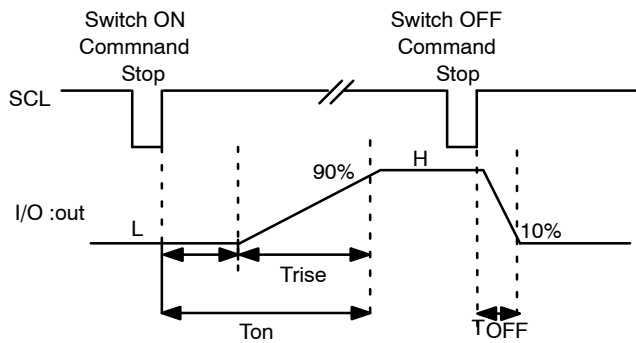

Figure 13. Turn On/Off Waveforms under Manual Mode

FSA4480

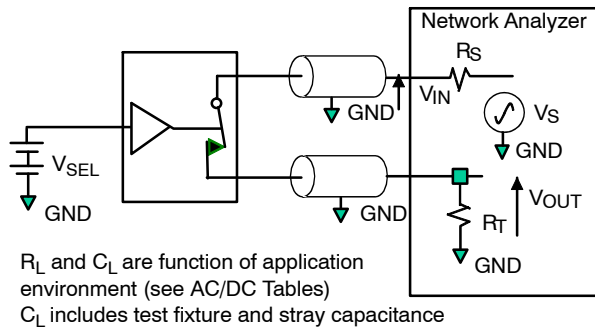

Figure 14. Bandwidth

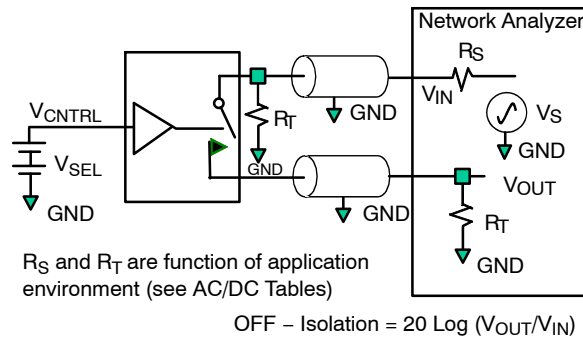

Figure 15. Channel Off Isolation

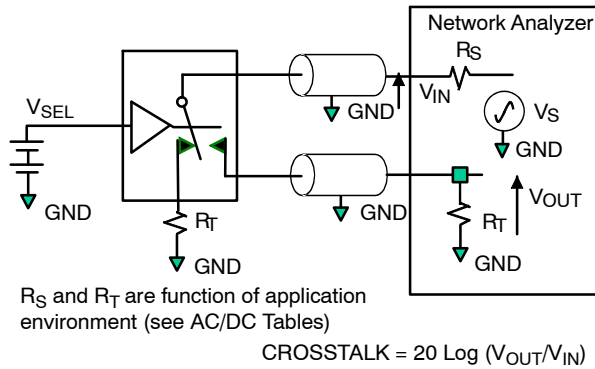

Figure 16. Adjacent Channel Crosstalk

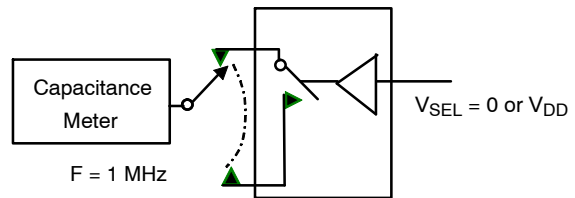

Figure 17. Channel Off Capacitance

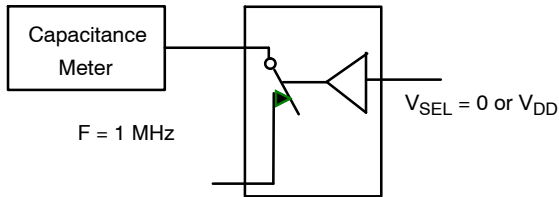

Figure 18. Channel On Capacitance

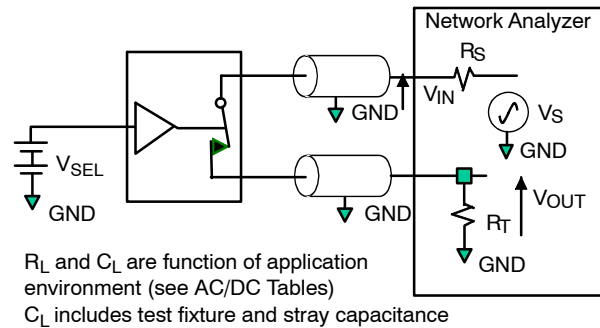

Figure 19. Total Harmonic Distortion (THD + N)

ORDERING INFORMATION

Part Number	Top Mark	Package	D	E	X	Y
FSA4480UCX	6D	25-Ball WLCSP	2.24mm	2.28mm	0.32mm	0.34mm

MECHANICAL CASE OUTLINE

PACKAGE DIMENSIONS

ON Semiconductor®



WLCSP25 2.24x2.28x0.586
CASE 567UZ
ISSUE B

DATE 03 JAN 2018

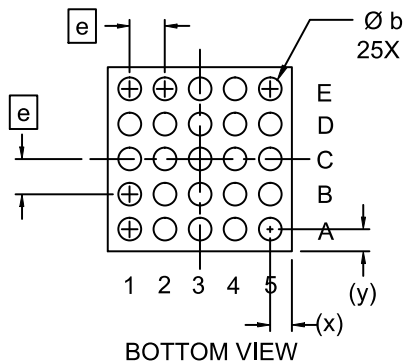
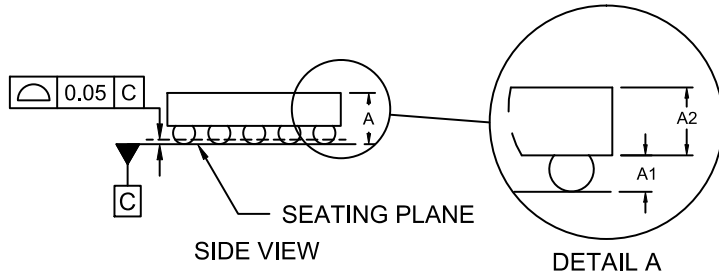
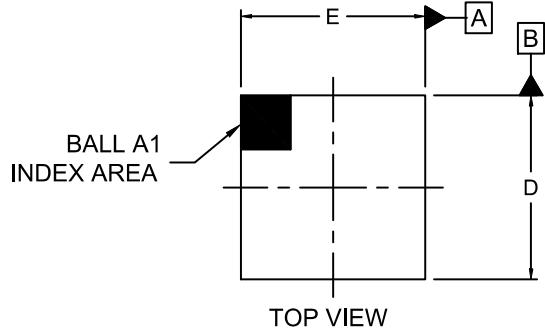

NOTES:

1. DIMENSIONING AND TOLERANCING PER ASME Y14.5M, 2009.
2. CONTROLLING DIMENSION: MILLIMETERS
3. DATUM C APPLIES TO THE SPHERICAL CROWN OF THE SOLDER BALLS

DIM	MILLIMETERS		
	MIN.	NOM.	MAX.
A	0.547	0.586	0.625
A1	0.178	0.208	0.238
A2	0.360	0.378	0.396
b	0.24	0.26	0.28
D	2.250	2.280	2.310
E	2.210	2.240	2.270
e	0.40 BSC		
x	0.305	0.320	0.335
y	0.325	0.340	0.355

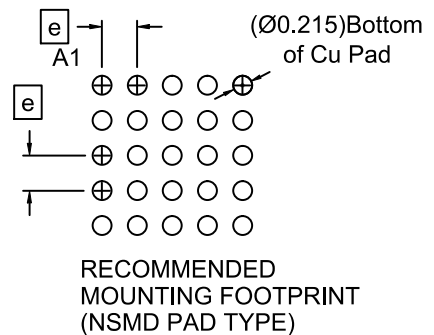

DOCUMENT NUMBER:	98AON73488G	Electronic versions are uncontrolled except when accessed directly from the Document Repository. Printed versions are uncontrolled except when stamped "CONTROLLED COPY" in red.
DESCRIPTION:	WLCSP25 2.24x2.28x0.586	PAGE 1 OF 1

ON Semiconductor and are trademarks of Semiconductor Components Industries, LLC dba ON Semiconductor or its subsidiaries in the United States and/or other countries. ON Semiconductor reserves the right to make changes without further notice to any products herein. ON Semiconductor makes no warranty, representation or guarantee regarding the suitability of its products for any particular purpose, nor does ON Semiconductor assume any liability arising out of the application or use of any product or circuit, and specifically disclaims any and all liability, including without limitation special, consequential or incidental damages. ON Semiconductor does not convey any license under its patent rights nor the rights of others.

onsemi, **Onsemi**, and other names, marks, and brands are registered and/or common law trademarks of Semiconductor Components Industries, LLC dba "**onsemi**" or its affiliates and/or subsidiaries in the United States and/or other countries. **onsemi** owns the rights to a number of patents, trademarks, copyrights, trade secrets, and other intellectual property. A listing of **onsemi**'s product/patent coverage may be accessed at www.onsemi.com/site/pdf/Patent-Marking.pdf. **onsemi** reserves the right to make changes at any time to any products or information herein, without notice. The information herein is provided "as-is" and **onsemi** makes no warranty, representation or guarantee regarding the accuracy of the information, product features, availability, functionality, or suitability of its products for any particular purpose, nor does **onsemi** assume any liability arising out of the application or use of any product or circuit, and specifically disclaims any and all liability, including without limitation special, consequential or incidental damages. Buyer is responsible for its products and applications using **onsemi** products, including compliance with all laws, regulations and safety requirements or standards, regardless of any support or applications information provided by **onsemi**. "Typical" parameters which may be provided in **onsemi** data sheets and/or specifications can and do vary in different applications and actual performance may vary over time. All operating parameters, including "Typicals" must be validated for each customer application by customer's technical experts. **onsemi** does not convey any license under any of its intellectual property rights nor the rights of others. **onsemi** products are not designed, intended, or authorized for use as a critical component in life support systems or any FDA Class 3 medical devices or medical devices with a same or similar classification in a foreign jurisdiction or any devices intended for implantation in the human body. Should Buyer purchase or use **onsemi** products for any such unintended or unauthorized application, Buyer shall indemnify and hold **onsemi** and its officers, employees, subsidiaries, affiliates, and distributors harmless against all claims, costs, damages, and expenses, and reasonable attorney fees arising out of, directly or indirectly, any claim of personal injury or death associated with such unintended or unauthorized use, even if such claim alleges that **onsemi** was negligent regarding the design or manufacture of the part. **onsemi** is an Equal Opportunity/Affirmative Action Employer. This literature is subject to all applicable copyright laws and is not for resale in any manner.

ADDITIONAL INFORMATION

TECHNICAL PUBLICATIONS:

Technical Library: www.onsemi.com/design/resources/technical-documentation
onsemi Website: www.onsemi.com

ONLINE SUPPORT: www.onsemi.com/support

For additional information, please contact your local Sales Representative at www.onsemi.com/support/sales

Looking for pricing, stock, or lifecycle information?

Click below to explore more details on WIN SOURCE:

 [View FSA4480UCX](#) on WIN SOURCE

 [ON Semiconductor](#) Information

Optimize Your Supply Chain with WIN SOURCE Solutions

-  Global Sourcing Solution
-  Obsolete Management
-  Cost Control Management
-  Shortage Management
-  Alternative Solution
-  Excess Inventory Management