



**THE DATASHEET OF
FODM8061R2**



High Noise Immunity, 3.3V/5V, 10 Mbit/sec Logic Gate Output (Open Collector) Optocoupler

FODM8061

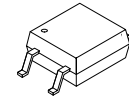

MFP5 4.1X4.4, 2.54P
CASE 100AM

Description

The FODM8061 is a 3.3 V/5 V high-speed logic gate output (open collector) optocoupler, which supports isolated communications allowing digital signals to communicate between systems without conducting ground loops or hazardous voltages. It utilizes onsemi's patented coplanar packaging technology, OPTOPLANAR®, and optimized IC design to achieve high noise immunity, characterized by high common mode transient immunity specifications.

This optocoupler consists of an AlGaAs LED at the input, optically coupled to a high speed integrated photo-detector logic gate. The output of the detector IC is an open collector schottky-clamped transistor. The coupled parameters are guaranteed over the wide temperature range of -40°C to +110°C. A maximum input signal of 5mA will provide a minimum output sink current of 13 mA (fan out of 8).

Features

- High Noise Immunity Characterized by Common Mode Transient Immunity (CMTI)
 - ◆ 20 kV/μs Minimum CMTI
- High Speed
 - ◆ 10 Mbit/sec Data Rate (NRZ)
 - ◆ 80 ns Max. Propagation Delay
 - ◆ 25 ns Max. Pulse Width Distortion
 - ◆ 40 ns Max. Propagation Delay Skew
- 3.3 V LVTTTL/LVCMOS Compatibility
- Specifications Guaranteed over 3 V to 5.5 V Supply Voltage and -40°C to +110°C Temperature Range
- Safety and Regulatory Approvals
 - ◆ UL1577, 3750 VAC_{RMS} for 1 min.
 - ◆ DIN EN/IEC60747-5-5

Applications

- Microprocessor System Interface
 - ◆ SPI, I²C
- Industrial Fieldbus Communications
 - ◆ DeviceNet, CAN, RS485
- Programmable Logic Control
- Isolated Data Acquisition System
- Voltage Level Translator
- Isolating MOSFET/IGBT Gate Drivers

Related resources

www.onsemi.com/products
www.onsemi.com/FODM611
www.onsemi.com/FODM8071

MARKING DIAGRAM

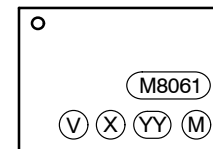

- M8061 = Device Number
 V = DIN EN/IEC60747-5-5 Option
 (Note: Only Appears on Parts Ordered with This Option)
 X = One Digit Year Code, e.g., '9'
 YY = Two Digit Work Week Ranging from '01' to '53'
 M = Assembly Package Code

FUNCTIONAL SCHEMATIC

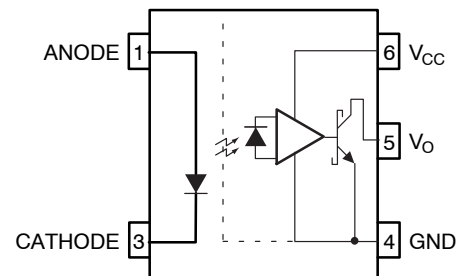

TRUTH TABLE

LED	Output
Off	High
On	Low

ORDERING INFORMATION

See detailed ordering and shipping information on page 9 of this data sheet.

FODM8061

PIN DEFINITIONS

Number	Name	Function Description
1	ANODE	Anode
3	CATHODE	Cathode
4	GND	Output Ground
5	V _O	Output Voltage
6	V _{CC}	Output Supply Voltage

SAFETY AND INSULATION RATINGS FOR MINI-FLAT PACKAGE (SO5 PIN)

(As per IEC60747-5-5. This optocoupler is suitable for "safe electrical insulation" only within the safety limit data. Compliance with the safety ratings shall be ensured by means of protective circuits.)

Symbol	Parameter	Min	Typ	Max	Unit
	Installation Classifications per DIN VDE 0110/1.89 Table 1	-	-	-	
	For Rated Main Voltage <150 Vrms	-	I-IV	-	
	For Rated Main Voltage <300 Vrms	-	I-III	-	
	Climatic Classification	-	40/110/21	-	
	Pollution Degree (DIN VDE 0110/1.89)	-	2	-	
CTI	Comparative Tracking Index	175	-	-	
V _{PR}	Input to Output Test Voltage, Method b, V _{IORM} × 1.875 = V _{PR} , 100% Production Test with t _m = 1 s, Partial Discharge <5 pC	1060	-	-	
V _{PR}	Input to Output Test Voltage, Method a, V _{IORM} × 1.5 = V _{PR} , Type and Sample Test with t _m = 60 s, Partial Discharge <5 pC	848	-	-	
V _{IORM}	Max Working Insulation Voltage	565	-	-	V _{peak}
V _{IOTM}	Highest Allowable Over Voltage	4000	-	-	V _{peak}
	External Creepage	5.0	-	-	mm
	External Clearance	5.0	-	-	mm
	Insulation Thickness	0.5	-	-	mm
T _{Case}	Safety Limit Values, Maximum Values Allowed in the Event of a Failure, Case Temperature	150	-	-	°C
R _{IO}	Insulation Resistance at T _S , V _{IO} = 500 V	10 ⁹	-	-	Ω

FODM8061

MAXIMUM RATINGS (T_A = 25°C unless otherwise noted)

Symbol	Parameter	Value	Unit
T _{STG}	Storage Temperature	-40 to +125	°C
T _{OPR}	Operating Temperature	-40 to +110	°C
T _J	Junction Temperature	-40 to +125	°C
T _{SOL}	Lead Solder Temperature (Refer to Reflow Temperature Profile)	260 for 10 s	°C
I _F	Forward Current	50	mA
V _R	Reverse Voltage	5.0	V
V _{CC}	Supply Voltage	0 to 7.0	V
V _O	Output Voltage	-0.5 to V _{CC} +0.5	V
I _O	Average Output Current	50	mA
PD _I	Input Power Dissipation (Note 1), (Note 2)	100	mW
PD _O	Output Power Dissipation (Note 1), (Note 2)	85	mW

Stresses exceeding those listed in the Maximum Ratings table may damage the device. If any of these limits are exceeded, device functionality should not be assumed, damage may occur and reliability may be affected.

1. No derate required to 110°C.

2. Functional operation under these conditions is not implied. Permanent damage may occur if the device is subjected to conditions outside these ratings.

RECOMMENDED OPERATING CONDITIONS

Symbol	Parameter	Min	Max	Unit
T _A	Ambient Operating Temperature	-40	+110	°C
V _{CC} , V _{DD}	Supply Voltages (Note 3)	3.0	5.5	V
V _{FL}	Logic Low Input Voltage	0	0.8	V
I _{FH}	Logic High Input Current (Note 4)	6.3	15	mA
I _{FL}	Logic Low Input Current	-	250	μA
N	Fan Out (at R _L = 1 kΩ)	-	5	TTL Loads
R _L	Output Pull-up Resistor	330	4k	Ω

Functional operation above the stresses listed in the Recommended Operating Ranges is not implied. Extended exposure to stresses beyond the Recommended Operating Ranges limits may affect device reliability.

3. 0.1 μF bypass capacitor must be connected between pins 4 and 6.

4. Recommended I_{FH} is 9.3 mA for operation above T_A = 100°C.

ISOLATION CHARACTERISTICS (T_A = 25°C, unless otherwise noted)

Symbol	Parameter	Test Conditions	Min	Typ	Max	Unit
V _{ISO}	Input-Output Isolation Voltage	f = 60 Hz, t = 1.0 min, I _{I-O} ≤ 10 μA (Note 5), (Note 6)	3750	-	-	VAC _{RMS}
R _{ISO}	Isolation Resistance	V _{I-O} = 500 V (Note 5)	-	10 ¹²	-	Ω
C _{ISO}	Isolation Capacitance	V _{I-O} = 0 V f = 1.0 Mhz (Note 5)	-	0.6	-	pF

5. Device is considered a two terminal device: Pins 1 and 3 are shorted, and Pins 4, 5, and 6 are shorted together.

6. 3,750 VAC_{RMS} for 1 minute duration is equivalent to 4,500 VAC_{RMS} for 1 second duration.

FODM8061

ELECTRICAL CHARACTERISTICS (Apply over all recommended conditions)

($T_A = -40^{\circ}\text{C}$ to $+110^{\circ}\text{C}$, $3.0\text{ V} \leq V_{CC} \leq 5.5\text{ V}$, unless otherwise noted)

Symbol	Parameter	Test Condition	Min	Typ*	Max	Unit	
INPUT CHARACTERISTICS							
V_F	Forward Voltage	$I_F = 10\text{ mA}$ (Figure 1)	1.05	1.45	1.8	V	
BV_R	Input Reverse Breakdown Voltage	$I_R = 10\text{ }\mu\text{A}$	5.0	–	–	V	
I_{FHL}	Threshold Input Current	$V_O = 0.6\text{ V}$, $I_{OL}(\text{sinking}) = 13\text{ mA}$	$T_A < 85^{\circ}\text{C}$, (Figure 2)	–	3.4	5.0	mA
			$T_A = 85^{\circ}\text{C}$ to 110°C	–	4.2	7.5	

OUTPUT CHARACTERISTICS

V_{OL}	Logic LOW Output Voltage	$I_F = \text{rated } I_{FHL}$, $I_{OL}(\text{sinking}) = 13\text{ mA}$ (Figure 3)	–	0.4	0.6	V
I_{OH}	Logic HIGH Output Current	$I_F = 250\text{ }\mu\text{A}$, $V_O = 3.3\text{ V}$, (Figure 4)	–	8.0	50.0	μA
		$I_F = 250\text{ }\mu\text{A}$, $V_O = 5.0\text{ V}$, (Figure 4)	–	2.1	30.0	μA
I_{CCL}	Logic LOW Output Supply Current	$I_F = 10\text{ mA}$, $V_{CC} = 3.3\text{ V}$, (Figure 5), (Figure 7)	–	6.0	8.5	mA
		$I_F = 10\text{ mA}$, $V_{CC} = 5.0\text{ V}$, (Figure 5), (Figure 7)	–	7.5	10.0	mA
I_{CCH}	Logic HIGH Output Supply Current	$I_F = 0\text{ mA}$, $V_{CC} = 3.3\text{ V}$, (Figure 6), (Figure 7)	–	4.0	7.0	mA
		$I_F = 0\text{ mA}$, $V_{CC} = 5.0\text{ V}$, (Figure 6), (Figure 7)	–	6.0	9.0	mA

Product parametric performance is indicated in the Electrical Characteristics for the listed test conditions, unless otherwise noted. Product performance may not be indicated by the Electrical Characteristics if operated under different conditions.

*Typical value is measured at $T_A = 25^{\circ}\text{C}$ and $V_{CC} = 3.3\text{ V}$.

SWITCHING CHARACTERISTICS (Apply over all recommended conditions)

($T_A = -40^{\circ}\text{C}$ to $+110^{\circ}\text{C}$, $3.0\text{ V} \leq V_{CC} \leq 5.5\text{ V}$, $I_F = 7.5\text{ mA}$, unless otherwise noted)

Symbol	Parameter	Test Condition	Min	Typ*	Max	Unit
Date Rate		$R_L = 350\text{ }\Omega$	–	–	10	Mbps
t_{PHL}	Propagation Delay Time to Logic Low Output	$R_L = 350\text{ }\Omega$, $C_L = 15\text{ pF}$, (Figure 8), (Figure 11)	–	43	80	ns
t_{PLH}	Propagation Delay Time to Logic High Output	$R_L = 350\text{ }\Omega$, $C_L = 15\text{ pF}$, (Figure 8), (Figure 11)	–	50	80	ns
PWD	Pulse Width Distortion, $ t_{PHL} - t_{PLH} $	$R_L = 350\text{ }\Omega$, $C_L = 15\text{ pF}$, (Figure 9)	–	7	25	ns
t_{PSK}	Propagation Delay Skew	$R_L = 350\text{ }\Omega$, $C_L = 15\text{ pF}$, (Note 7)	–	–	40	ns
t_R	Output Rise Time, (10% to 90%)	$R_L = 350\text{ }\Omega$, $C_L = 15\text{ pF}$, (Figure 10), (Figure 11)	–	20	–	ns
t_F	Output Fall Time, (90% to 10%)	$R_L = 350\text{ }\Omega$, $C_L = 15\text{ pF}$, (Figure 10), (Figure 11)	–	10	–	ns
$ CM_H $	Common Mode Transient Immunity at Output High	$I_F = 0\text{ mA}$, $V_O > 0.8 \times V_{CC}$, $V_{CM} = 1000\text{ V}$ (Note 8), (Figure 12)	20	40	–	kV/ μs
$ CM_L $	Common Mode Transient Immunity at Output Low	$I_F = 7.5\text{ mA}$, $V_O < 0.8 \times V_{CC}$, $V_{CM} = 1000\text{ V}$ (Note 8), (Figure 12)	20	40	–	kV/ μs

Product parametric performance is indicated in the Electrical Characteristics for the listed test conditions, unless otherwise noted. Product performance may not be indicated by the Electrical Characteristics if operated under different conditions.

*Typical value is measured at $T_A = 25^{\circ}\text{C}$ and $V_{CC} = 3.3\text{ V}$.

- t_{PSK} is equal to the magnitude of the worst case difference in t_{PHL} and/or t_{PLH} that will be seen between any two units from the same manufacturing date code that are operated at same case temperature ($\pm 5^{\circ}\text{C}$), at same operating conditions, with equal loads ($R_L = 350\text{ }\Omega$ and $C_L = 15\text{ pF}$), and with an input rise time less than 5 ns.
- Common mode transient immunity at output high is the maximum tolerable positive dV_{cm}/dt on the leading edge of the common mode impulse signal, V_{cm} , to assure that the output will remain high. Common mode transient immunity at output low is the maximum tolerable negative dV_{cm}/dt on the trailing edge of the common pulse signal, V_{cm} , to assure that the output will remain low.

TYPICAL PERFORMANCE CURVES

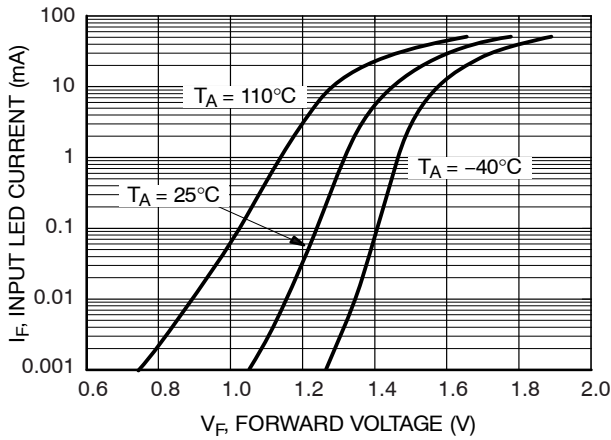

Figure 1. Input LED Current vs. Forward Voltage

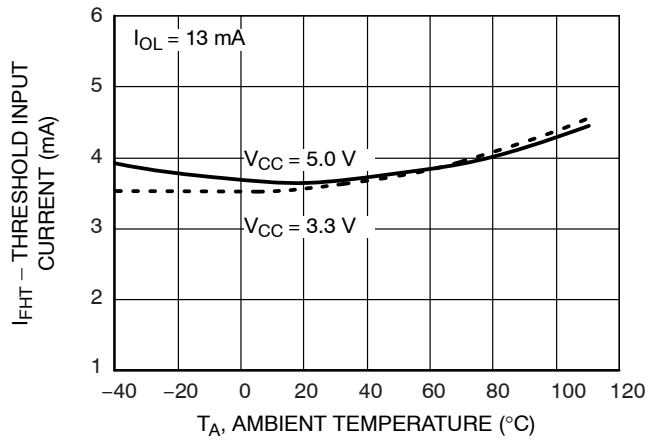

Figure 2. Threshold Input Current vs. Ambient Temperature

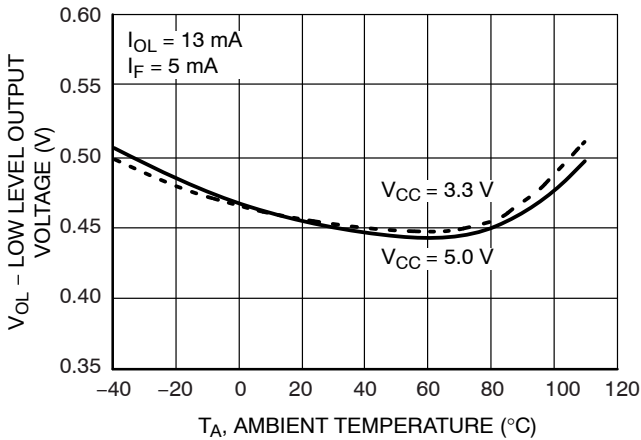

Figure 3. Low Level Output Voltage vs. Ambient Temperature

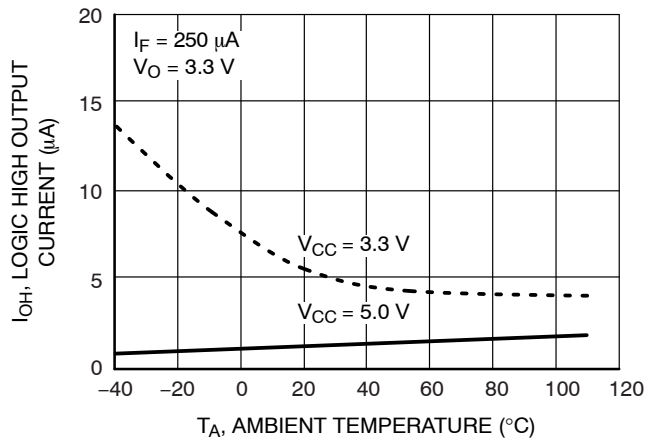

Figure 4. Logic High Output Current vs. Ambient Temperature

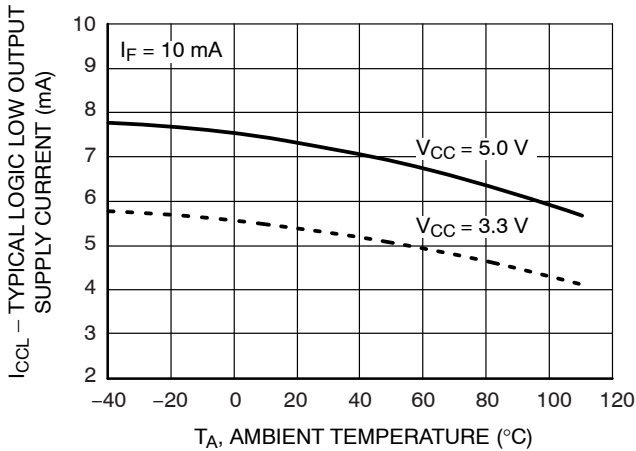

Figure 5. Typical Logic Low Output Supply Current vs. Ambient Temperature

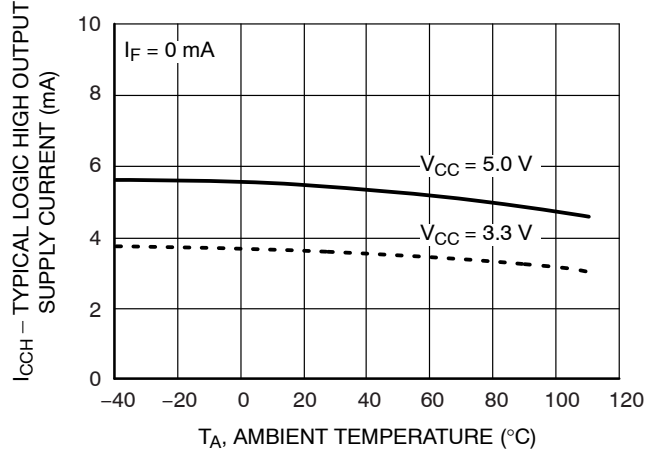

Figure 6. Typical Logic High Output Supply Current vs. Ambient Temperature

TYPICAL PERFORMANCE CURVES (CONTINUED)

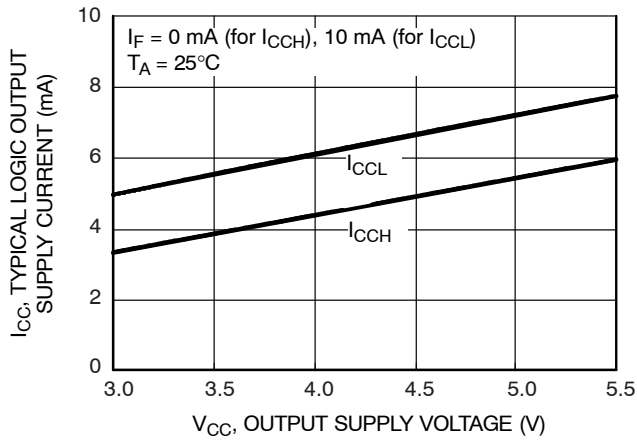

Figure 7. Typical Logic Output Supply Current vs. Output Supply Voltage

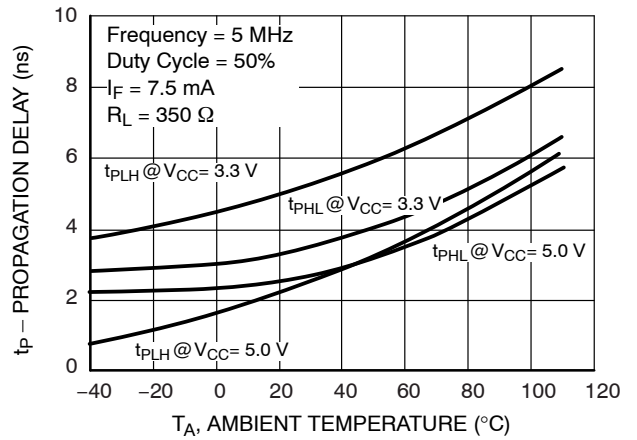

Figure 8. Typical Propagation Delay vs. Ambient Temperature

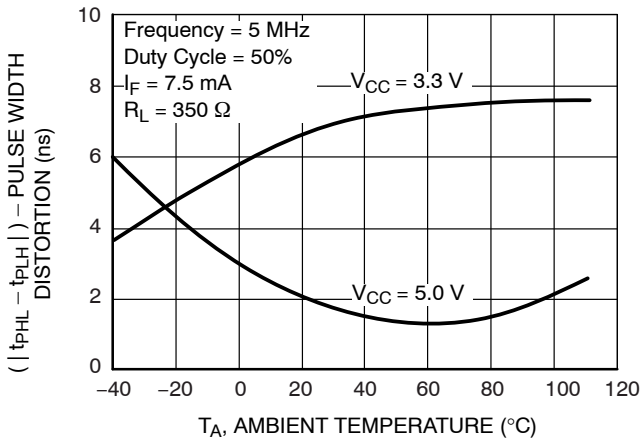

Figure 9. Typical Pulse Width Distortion vs. Ambient Temperature

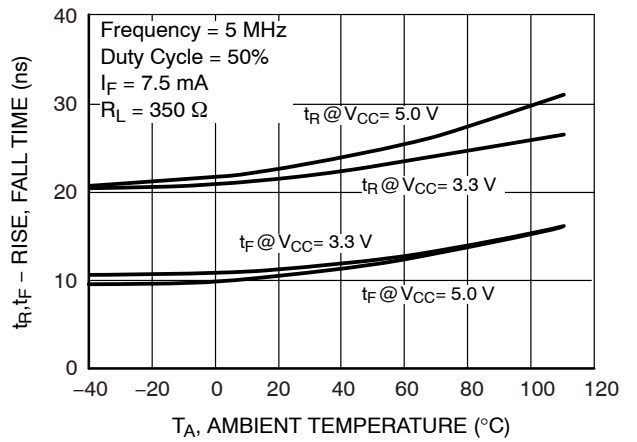

Figure 10. Typical Rise and Fall Time vs. Ambient Temperature

FODM8061

SCHEMATICS

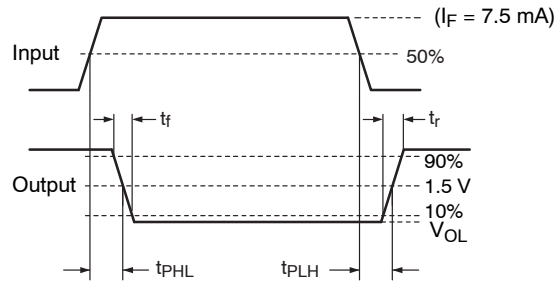
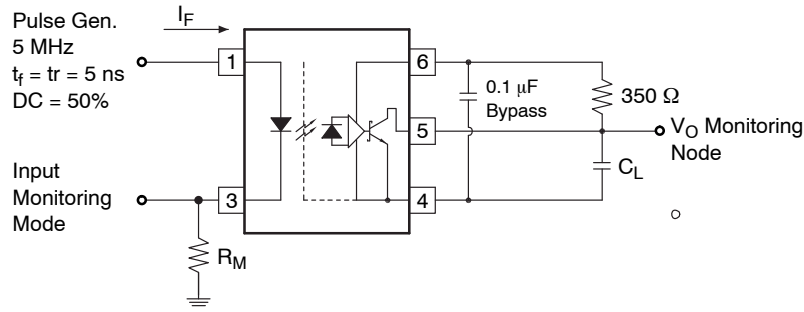

Figure 11. Test Circuit for Propagation Delay Time, Rise Time and Fall Time

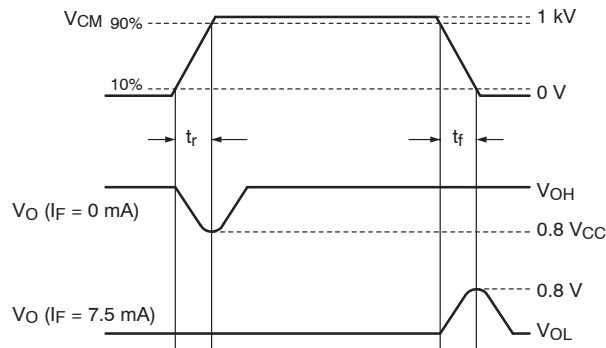
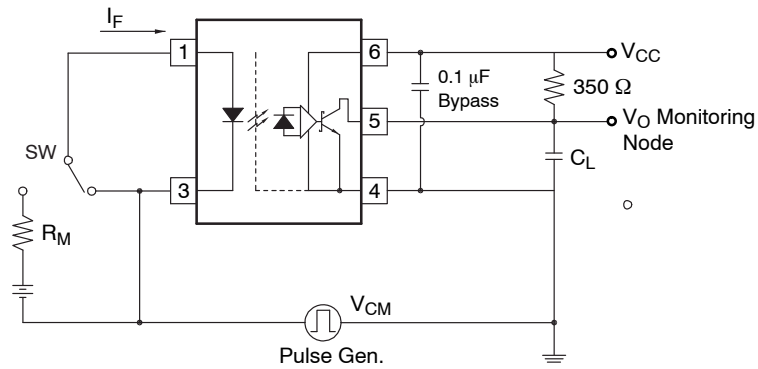

Figure 12. Test Circuit for Instantaneous Common Mode Rejection Voltage

REFLOW PROFILE

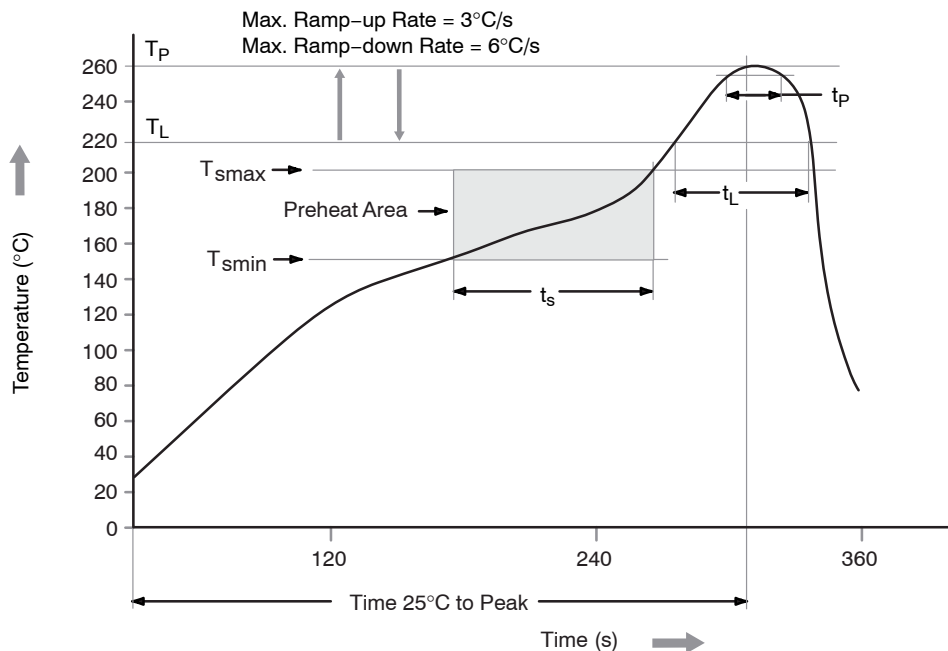

Figure 13. Reflow Profile

Table 1. REFLOW PROFILE

Profile Feature	Pb-Free Assembly Profile
Temperature Minimum (T_{smin})	150°C
Temperature Maximum (T_{smax})	200°C
Time (t_s) from (T_{smin} to T_{smax})	60 – 120 seconds
Ramp-up Rate (t_L to t_p)	3°C/second max.
Liquidous Temperature (T_L)	217°C
Time (t_L) Maintained Above (T_L)	60 – 150 seconds
Peak Body Package Temperature	260°C +0°C / -5°C
Time (t_p) within 5°C of 260°C	30 seconds
Ramp-down Rate (T_P to T_L)	6°C/second max.
Time 25°C to Peak Temperature	8 minutes max.

FODM8061

ORDERING INFORMATION

Part Number	Package	Shipping†
FODM8061	MFP5 4.1X4.4, 2.54P (Pb-Free)	100 Units / Tube
FODM8061R2	MFP5 4.1X4.4, 2.54P (Pb-Free)	2500 / Tape & Reel
FODM8061V	MFP5 4.1X4.4, 2.54P IEC60747-5-5 (Pb-Free)	100 Units / Tube
FODM8061R2V	MFP5 4.1X4.4, 2.54P IEC60747-5-5 (Pb-Free)	2500 / Tape & Reel

†For information on tape and reel specifications, including part orientation and tape sizes, please refer to our Tape and Reel Packaging Specifications Brochure, BRD8011/D.

OPTOPLANAR is a registered trademark of Semiconductor Components Industries, LLC dba "onsemi" or its affiliates and/or subsidiaries in the United States and/or other countries.

MECHANICAL CASE OUTLINE
PACKAGE DIMENSIONS

ON Semiconductor®



MFP5 4.1X4.4, 2.54P
CASE 100AM
ISSUE 0

DATE 31 AUG 2016

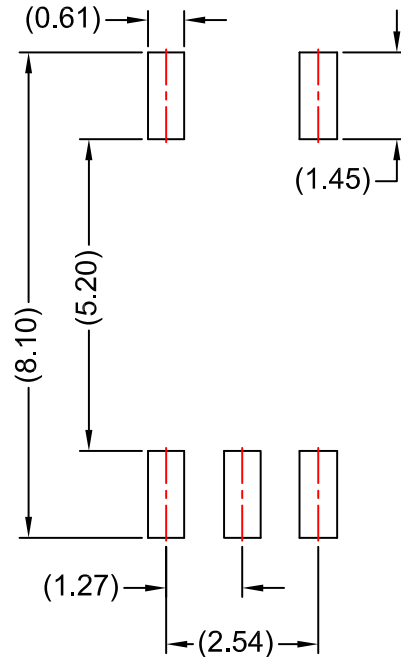
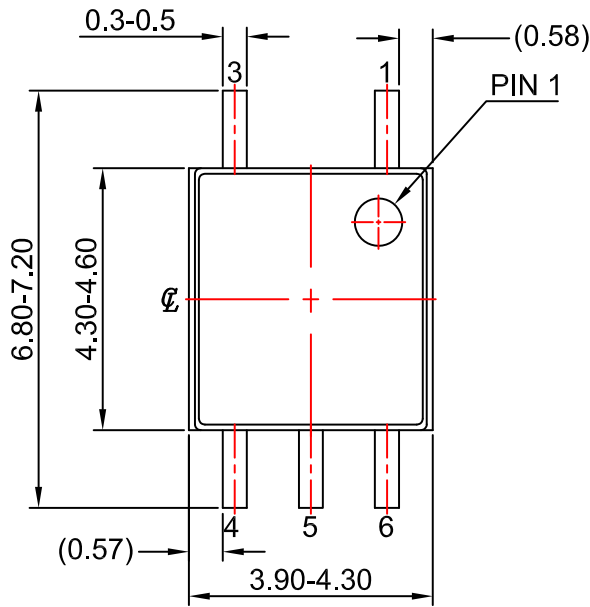

LAND PATTERN RECOMMENDATION

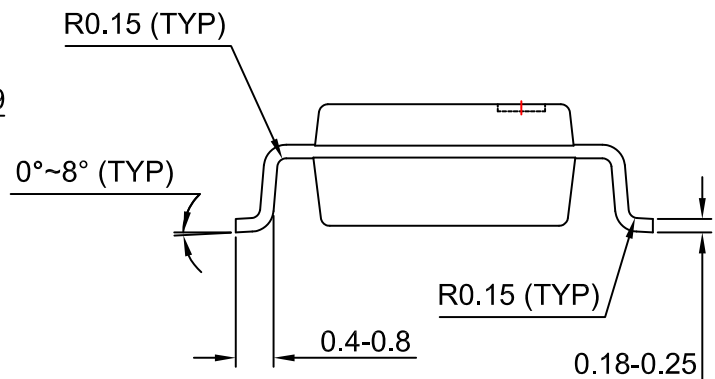
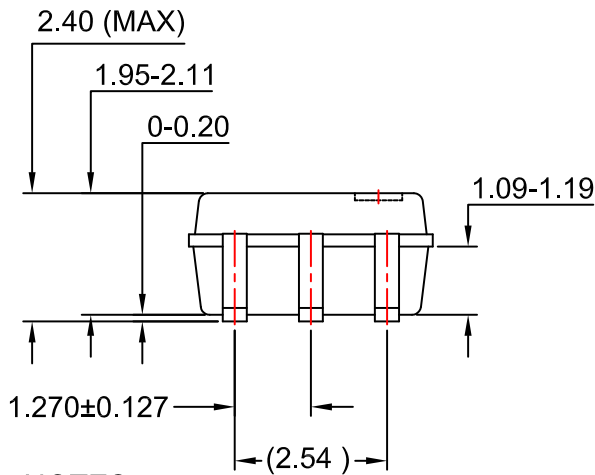

NOTES:

- A) NO STANDARD APPLIES TO THIS PACKAGE
- B) ALL DIMENSIONS ARE IN MILLIMETERS.
- C) DIMENSIONS ARE EXCLUSIVE OF BURRS, MOLD FLASH, AND TIE BAR EXTRUSION

DOCUMENT NUMBER:	98AON13486G	Electronic versions are uncontrolled except when accessed directly from the Document Repository. Printed versions are uncontrolled except when stamped "CONTROLLED COPY" in red.
DESCRIPTION:	MFP5 4.1X4.4, 2.54P	PAGE 1 OF 1

ON Semiconductor and are trademarks of Semiconductor Components Industries, LLC dba ON Semiconductor or its subsidiaries in the United States and/or other countries. ON Semiconductor reserves the right to make changes without further notice to any products herein. ON Semiconductor makes no warranty, representation or guarantee regarding the suitability of its products for any particular purpose, nor does ON Semiconductor assume any liability arising out of the application or use of any product or circuit, and specifically disclaims any and all liability, including without limitation special, consequential or incidental damages. ON Semiconductor does not convey any license under its patent rights nor the rights of others.

onsemi, **Onsemi**, and other names, marks, and brands are registered and/or common law trademarks of Semiconductor Components Industries, LLC dba "**onsemi**" or its affiliates and/or subsidiaries in the United States and/or other countries. **onsemi** owns the rights to a number of patents, trademarks, copyrights, trade secrets, and other intellectual property. A listing of **onsemi**'s product/patent coverage may be accessed at www.onsemi.com/site/pdf/Patent-Marking.pdf. **onsemi** reserves the right to make changes at any time to any products or information herein, without notice. The information herein is provided "as-is" and **onsemi** makes no warranty, representation or guarantee regarding the accuracy of the information, product features, availability, functionality, or suitability of its products for any particular purpose, nor does **onsemi** assume any liability arising out of the application or use of any product or circuit, and specifically disclaims any and all liability, including without limitation special, consequential or incidental damages. Buyer is responsible for its products and applications using **onsemi** products, including compliance with all laws, regulations and safety requirements or standards, regardless of any support or applications information provided by **onsemi**. "Typical" parameters which may be provided in **onsemi** data sheets and/or specifications can and do vary in different applications and actual performance may vary over time. All operating parameters, including "Typicals" must be validated for each customer application by customer's technical experts. **onsemi** does not convey any license under any of its intellectual property rights nor the rights of others. **onsemi** products are not designed, intended, or authorized for use as a critical component in life support systems or any FDA Class 3 medical devices or medical devices with a same or similar classification in a foreign jurisdiction or any devices intended for implantation in the human body. Should Buyer purchase or use **onsemi** products for any such unintended or unauthorized application, Buyer shall indemnify and hold **onsemi** and its officers, employees, subsidiaries, affiliates, and distributors harmless against all claims, costs, damages, and expenses, and reasonable attorney fees arising out of, directly or indirectly, any claim of personal injury or death associated with such unintended or unauthorized use, even if such claim alleges that **onsemi** was negligent regarding the design or manufacture of the part. **onsemi** is an Equal Opportunity/Affirmative Action Employer. This literature is subject to all applicable copyright laws and is not for resale in any manner.

ADDITIONAL INFORMATION

TECHNICAL PUBLICATIONS:

Technical Library: www.onsemi.com/design/resources/technical-documentation
onsemi Website: www.onsemi.com



ONLINE SUPPORT: www.onsemi.com/support

For additional information, please contact your local Sales Representative at www.onsemi.com/support/sales



Looking for pricing, stock, or lifecycle information?

Click below to explore more details on WIN SOURCE:

-  [View FODM8061R2 on WIN SOURCE](#)
-  [ON Semiconductor](#) Information

Optimize Your Supply Chain with WIN SOURCE Solutions

-  Global Sourcing Solution
-  Obsolete Management
-  Cost Control Management
-  Shortage Management
-  Alternative Solution
-  Excess Inventory Management