

LED Drivers for LCD BackLights

Multifunction Backlight LED Driver for Small LCD Panels (Charge Pump Type)



BD6083GUL

No.10040EAT16

●Description

BD6083GUL is "Intelligent LED Driver" that is the most suitable for the cellular phone.

It has 3 - 6LED driver and output variable LDO4ch for LCD Backlight.

It has ALC function that is "Low Power Consumption System" realized.

It can be developed widely from the high End model to the Low End model.

As it has charge pump circuit for DCDC, it is no need to use coils, and it contributes to small space.

VCSP50L3 (3.15mm x 3.15mm 0.5mm pitch)

It adopts the very thin CSP package that is the most suitable for the slim phone.

●Features

- 1) Total 3 - 6LEDs driver for LCD Backlight
 - It has 4LEDs (it can select 4LED or 3LED) for exclusive use of Main and 2LEDs which can chose independent control or a main allotment by resister setting.
 - Main Group" can be controlled by Auto Luminous Control (ALC) system.
 - "Main Group" can be controlled by external PWM signal.
 - ON/ Off and a setup of LED current are possible at the time of the independent control by the independence.
- 2) Ambient Light sensor interface
 - Incorporates various functions such as a sensor bias adjustment function, an ADC with an average filter, a gainoffset adjustment function and an LOG conversion function so that options can be increased for illumination intensity sensors (Photo Diode, Photo Transistor, Photo IC (Linear/LOG)).
 - Incorporates an auto gain switching function for suppressing an illumination intensity sensor current at high illumination intensity and improving sensitivity at low illumination intensity
 - Capable of customizing an LED current value according to a table setting.
 - Slope control loading and an independent control change are possible.
- 3) Charge Pump DC/DC for LED driver
 - It has x1/x1.5/ x2 mode that will be selected automatically.
 - The most suitable voltage up magnification is controlled automatically by LED port voltage.
 - Soft start functions、 Over voltage protection (Auto-return type),Over current protection (Auto-return type) loading
- 4) 4ch Series Regulator (LDO)
 - It has selectable output voltage by the register.(16 steps)
 - LDO1, LDO2, LDO3, LDO4: I_{max}=150mA
- 5) Thermal shutdown
- 6) I²C BUS FS mode (max 400 kHz) Compatibility

●Absolute Maximum Ratings (Ta=25 °C)

Parameter	Symbol	Ratings	Unit
Maximum Voltage	V _{MAX}	7	V
Power Dissipation	P _d	1280 ^(Note)	mW
Operating Temperature Range	T _{opr}	-30 ~ +85	°C
Storage Temperature Range	T _{stg}	-55 ~ +150	°C

(Note) Power dissipation deleting is 10.24mW/ °C , when it's used in over 25 °C.
(It's deleting is on the board that is ROHM's standard)

●Operating Conditions (V_{BAT}≥V_{IO}, Ta=-30~85 °C)

Parameter	Symbol	Limits	Unit
V _{BAT} Input Voltage	V _{BAT}	2.7 ~ 5.5	V
V _{IO} Pin Voltage	V _{IO}	1.65 ~ 3.3	V

●Electrical Characteristics (Unless otherwise specified, Ta=25°C, VBAT=3.6V, VIO=1.8V)

Parameter	Symbol	Limits			Unit	Conditions
		Min.	Typ.	Max.		
【Circuit Current】						
VBAT Circuit Current 1	IBAT1	-	0.1	3.0	μA	RESETB=0V, VIO= 0V
VBAT Circuit Current 2	IBAT2	-	0.5	3.0	μA	RESETB=0V, VIO=1.8V
VBAT Circuit Current 3	IBAT3	-	61	65	mA	DC/DC x1 mode, Io=60mA VBAT=4.0V
VBAT Circuit Current 4	IBAT4	-	92	102	mA	DC/DC x1.5 mode, Io=60mA VBAT=3.6V
VBAT Circuit Current 5	IBAT5	-	123	140	mA	DC/DC x2 mode, Io=60mA VBAT=2.7V
VBAT Circuit Current 6	IBAT6	-	0.25	1.0	mA	ALC Operating ALCEN=1, AD cycle=0.5s setting Except sensor current
VBAT Circuit Current 7	IBAT7	-	90	150	μA	LDO1,2=ON, ILDO=0mA
VBAT Circuit Current 8	IBAT8	-	90	150	μA	LDO3,4=ON, ILDO=0mA
【LED Driver】						
LED Current Step (Setup)	ILEDSTP1	128			Step	LED1~6
LED Current Step (At slope)	ILEDSTP2	256			Step	LED1~6
LED Maximum Setup Current	IMAXWLED	-	25.6	-	mA	LED1~6
LED Current Accuracy	IWLED	-7%	15	+7%	mA	ILED=15mA setting, VLED=1.0V
LED Current Matching	ILEDMT	-	-	4	%	Between LED1~6 at VLED=1.0V, ILED=15mA
LED OFF Leak Current	ILKLED	-	-	1.0	μA	VLED=4.5V
【DC/DC(Charge Pump)】						
Output Voltage	VoCP	-	Vf+0.2	Vf+0.25	V	Vf is forward direction of LED
Drive Ability	IOUT	-	-	150	mA	VBAT≥3.2V, VOUT=3.9V
Switching Frequency	fosc	0.8	1.0	1.2	MHz	
Over Voltage Protection Detect Voltage	OVP	-	5.6	-	V	
Over Current Protection Detect Current	OCP	-	250	375	mA	VOUT=0V
【Sensor Interface】						
SBIAS Output Voltage	VoS	2.85	3.0	3.15	V	Io=200μA
SBIAS Maximum Output Current	IomaxS	30	-	-	mA	
SBIAS Discharge Resister at OFF	ROFFS	-	1.0	1.5	kΩ	
SSENS Input Range	VISS	0	-	VoS × 255/256	V	
ADC Resolution	ADRES	8			bit	
ADC Integral Calculus Non-linearity	ADINL	-3	-	+3	LSB	
ADC Differential Calculus Non-linearity	ADDNL	-1	-	+1	LSB	

●Electrical Characteristics (Unless otherwise specified, Ta=25°C, VBAT=3.6V, VIO=1.8V)

Parameter	Symbol	Limits			Unit	Condition
		Min.	Typ.	Max.		
【Regulator (LDO1)】						
Output Voltage	Vo1	1.164	1.20	1.236	V	Io=50mA
		1.261	1.30	1.339	V	Io=50mA
		1.455	1.50	1.545	V	Io=50mA
		1.552	1.60	1.648	V	Io=50mA
		1.746	1.80	1.854	V	Io=50mA <Initial Voltage>
		2.134	2.20	2.266	V	Io=50mA
		2.328	2.40	2.472	V	Io=50mA
		2.425	2.50	2.575	V	Io=50mA
		2.522	2.60	2.678	V	Io=50mA
		2.619	2.70	2.781	V	Io=50mA
		2.716	2.80	2.884	V	Io=50mA
		2.813	2.90	2.987	V	Io=50mA
		2.910	3.00	3.090	V	Io=50mA
		3.007	3.10	3.193	V	Io=50mA
		3.104	3.20	3.296	V	Io=50mA
3.201	3.30	3.399	V	Io=50mA		
Output Current	Io1	-	-	150	mA	Vo=1.8V
Dropout Voltage	Vsat1	-	0.2	0.3	V	VBAT=2.5V, Io=150mA, Vo=2.8V
Load Stability	ΔVo11	-	10	60	mV	Io=1~150mA, Vo=1.8V
Input Voltage Stability	ΔVo12	-	10	60	mV	VBAT=3.4~4.5V, Io=50mA, Vo=1.8V
Ripple Rejection Ratio	RR1	-	65	-	dB	f=100Hz, Vin=200mVp-p, Vo=1.2V Io=50mA, BW=20Hz~20kHz
Short Circuit Current Limit	Ilim1	-	200	400	mA	Vo=0V
Discharge Resister at OFF	ROFF1	-	1.0	1.5	kΩ	
【Regulator (LDO2)】						
Output Voltage	Vo2	1.164	1.20	1.236	V	Io=50mA
		1.261	1.30	1.339	V	Io=50mA
		1.455	1.50	1.545	V	Io=50mA
		1.552	1.60	1.648	V	Io=50mA
		1.746	1.80	1.854	V	Io=50mA
		2.134	2.20	2.266	V	Io=50mA
		2.328	2.40	2.472	V	Io=50mA
		2.425	2.50	2.575	V	Io=50mA <Initial Voltage>
		2.522	2.60	2.678	V	Io=50mA
		2.619	2.70	2.781	V	Io=50mA
		2.716	2.80	2.884	V	Io=50mA
		2.813	2.90	2.987	V	Io=50mA
		2.910	3.00	3.090	V	Io=50mA
		3.007	3.10	3.193	V	Io=50mA
		3.104	3.20	3.296	V	Io=50mA
3.201	3.30	3.399	V	Io=50mA		
Output Current	Io2	-	-	150	mA	Vo=2.5V
Dropout Voltage	Vsat2	-	0.2	0.3	V	VBAT=2.5V, Io=150mA, Vo=2.8V
Load Stability	Δvo21	-	10	60	mV	Io=1~150mA, Vo=2.5V
Input Voltage Stability	Δvo22	-	10	60	mV	VBAT=3.4~4.5V, Io=50mA, Vo=2.5V
Ripple Rejection Ratio	RR2	-	65	-	dB	f=100Hz, Vin=200mVp-p, Vo=1.2V Io=50mA, BW=20Hz~20kHz
Short Circuit Current Limit	Ilim2	-	200	400	mA	Vo=0V
Discharge Resister at OFF	ROFF2	-	1.0	1.5	kΩ	

●Electrical Characteristics (Unless otherwise specified, Ta=25°C, VBAT=3.6V, VIO=1.8V)

Parameter	Symbol	Limits			Unit	Condition
		Min.	Typ.	Max.		
【Regulator (LDO3)】						
Output Voltage	Vo3	1.164	1.20	1.236	V	Io=50mA
		1.261	1.30	1.339	V	Io=50mA
		1.455	1.50	1.545	V	Io=50mA
		1.552	1.60	1.648	V	Io=50mA
		1.746	1.80	1.854	V	Io=50mA <Initial Voltage>
		2.134	2.20	2.266	V	Io=50mA
		2.328	2.40	2.472	V	Io=50mA
		2.425	2.50	2.575	V	Io=50mA
		2.522	2.60	2.678	V	Io=50mA
		2.619	2.70	2.781	V	Io=50mA
		2.716	2.80	2.884	V	Io=50mA
		2.813	2.90	2.987	V	Io=50mA
		2.910	3.00	3.090	V	Io=50mA
		3.007	3.10	3.193	V	Io=50mA
		3.104	3.20	3.296	V	Io=50mA
3.201	3.30	3.399	V	Io=50mA		
Output Current	Io3	-	-	150	mA	Vo=1.8V
Dropout Voltage	Vsat3	-	0.2	0.3	V	VBAT=2.5V, Io=150mA, Vo=2.8V
Load Stability	ΔVo31	-	10	60	mV	Io=1~150mA, Vo=1.8V
Input Voltage Stability	ΔVo32	-	10	60	mV	VBAT=3.4~4.5V, Io=50mA, Vo=1.8V
Ripple Rejection Ratio	RR3	-	65	-	dB	f=100Hz, Vin=200mVp-p, Vo=1.2V Io=50mA, BW=20Hz~20kHz
Short Circuit Current Limit	Ilim3	-	200	400	mA	Vo=0V
Discharge Resister at OFF	ROFF3	-	1.0	1.5	kΩ	
【Regulator (LDO4)】						
Output Voltage	Vo4	1.164	1.20	1.236	V	Io=50mA
		1.261	1.30	1.339	V	Io=50mA
		1.455	1.50	1.545	V	Io=50mA
		1.552	1.60	1.648	V	Io=50mA
		1.746	1.80	1.854	V	Io=50mA
		2.134	2.20	2.266	V	Io=50mA
		2.328	2.40	2.472	V	Io=50mA
		2.425	2.50	2.575	V	Io=50mA
		2.522	2.60	2.678	V	Io=50mA
		2.619	2.70	2.781	V	Io=50mA
		2.716	2.80	2.884	V	Io=50mA <Initial Voltage>
		2.813	2.90	2.987	V	Io=50mA
		2.910	3.00	3.090	V	Io=50mA
		3.007	3.10	3.193	V	Io=50mA
		3.104	3.20	3.296	V	Io=50mA
3.201	3.30	3.399	V	Io=50mA		
Output Current	Io4	-	-	150	mA	Vo=2.8V
Dropout Voltage	Vsat4	-	0.2	0.3	V	VBAT=2.5V, Io=150mA, Vo=2.8V
Load Stability	ΔVo41	-	10	60	mV	Io=1~150mA, Vo=2.8V
Input Voltage Stability	ΔVo42	-	10	60	mV	VBAT=3.4~4.5V, Io=50mA, Vo=2.8V
Ripple Rejection Ratio	RR4	-	65	-	dB	f=100Hz, Vin=200mVp-p, Vo=1.2V Io=50mA, BW=20Hz~20kHz
Short Circuit Current Limit	Ilim4	-	200	400	mA	Vo=0V
Discharge Resister at OFF	ROFF4	-	1.0	1.5	kΩ	

●Electrical Characteristics (Unless otherwise specified, Ta=25°C, VBAT=3.6V, VIO=1.8V)

Parameter	Symbol	Limits			Unit	Condition
		Min.	Typ.	Max.		
【SDA, SCL】 (I²C Interface)						
L Level Input Voltage	VILI	-0.3	-	0.25 ×VIO	V	
H Level Input Voltage	VIHI	0.75 ×VIO	-	VBAT+0.3	V	
Hysteresis of Schmitt trigger Input	Vhysl	0.05 ×VIO	-	-	V	
L Level Output Voltage	VOLI	0	-	0.3	V	SDA Pin, IOL=3 mA
Input Current	linl	-	-	1	μA	Input Voltage= 0.1×VIO ~ 0.9×VIO
【RESETB】 (CMOS Input Pin)						
L Level Input Voltage	VILR	-0.3	-	0.25 ×VIO	V	
H Level Input Voltage	VIHR	0.75 ×VIO	-	VBAT+0.3	V	
Input Current	linR	-	-	1	μA	Input Voltage = 0.1×VIO ~ 0.9×VIO
【WPWMIN】 (NMOS Input Pin)						
L Level Input Voltage	VILA	-0.3	-	0.3	V	
H Level Input Voltage	VIHA	1.4	-	VBAT+0.3	V	
Input Current	linA	-	3.6	10	μA	Input Voltage = 1.8V
PWM Input Minimum High Pulse Width	PWmin	250	-	-	μs	WPWMIN Pin
【GC1, GC2】 (Sensor Gain Control CMOS Output Pin)						
L Level Output Voltage	VOLS	-	-	0.2	V	IOL=1mA
H Level Output Voltage	VOHS	VoS-0.2	-	-	V	IOH=1mA

●Power Dissipation (On the ROHM's standard board)

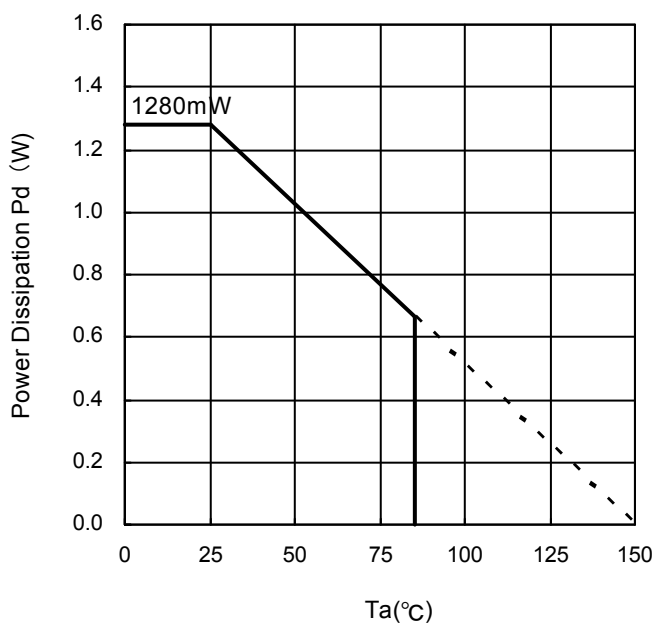

Information of the ROHM's standard board
 Material: glass-epoxy
 Size : 50mm × 58mm × 1.75mm(8th layer)
 Wiring pattern figure Refer to after page.

Fig.1 Power Dissipation

●Block Diagram / Application Circuit Example 1

6LED + ALC +PWM

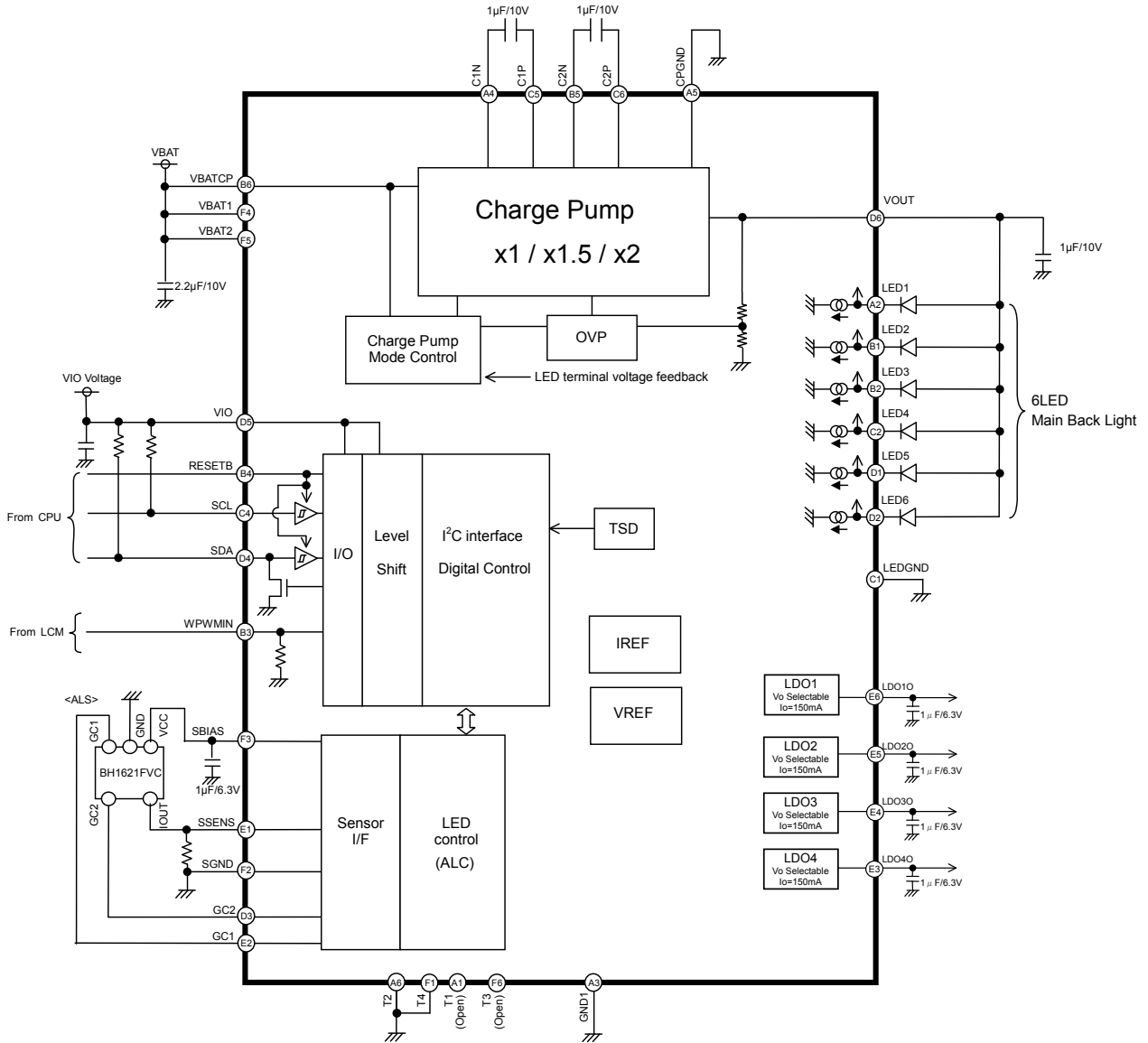

Fig.2 Block Diagram / Application Circuit Example 1

●Block Diagram / Application Circuit Example 2

5LED + ALC +PWM

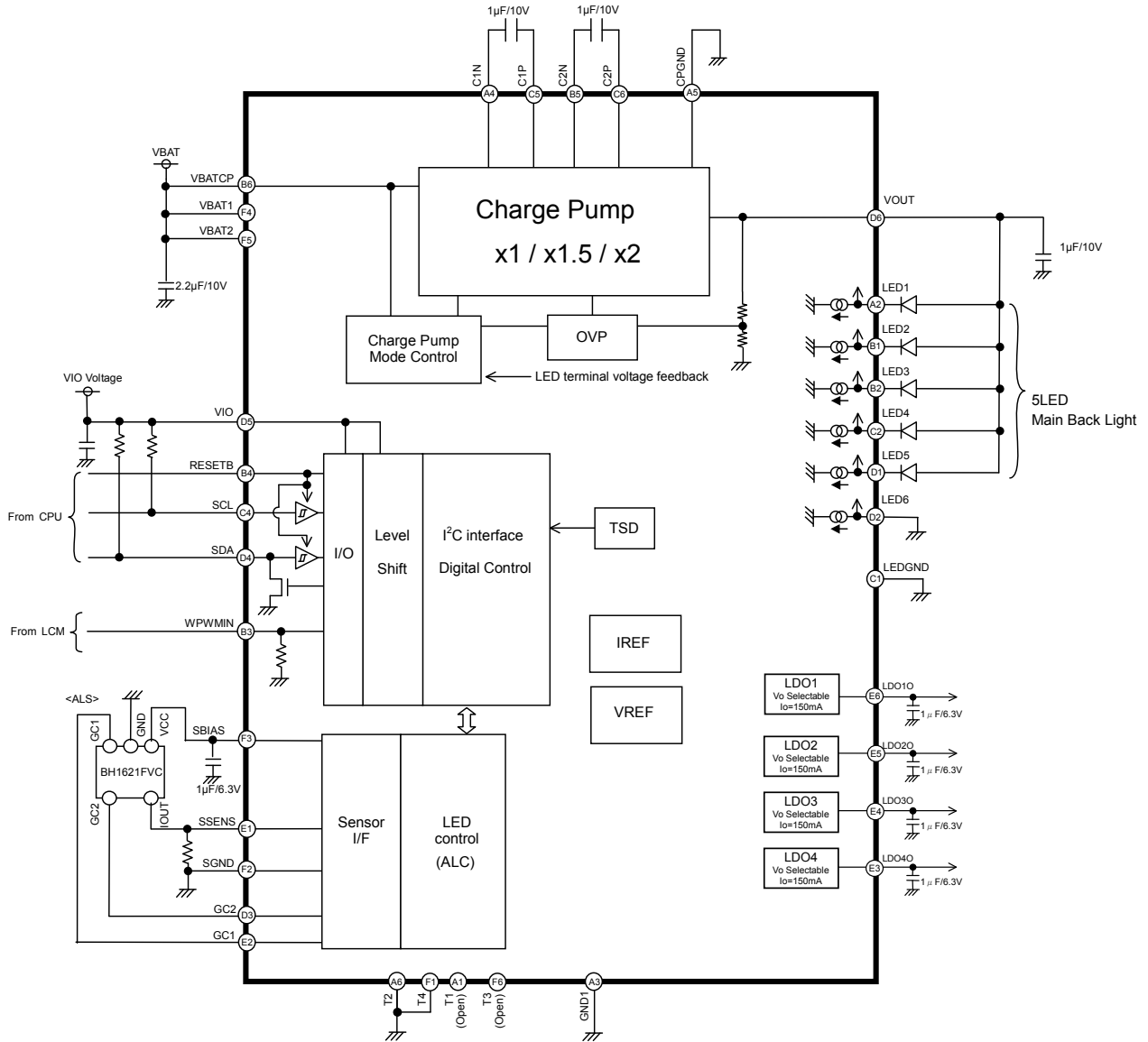

Fig.3 Block Diagram / Application Circuit Example 2

●Block Diagram / Application Circuit Example 3

4LED + 2LED + ALC +PWM

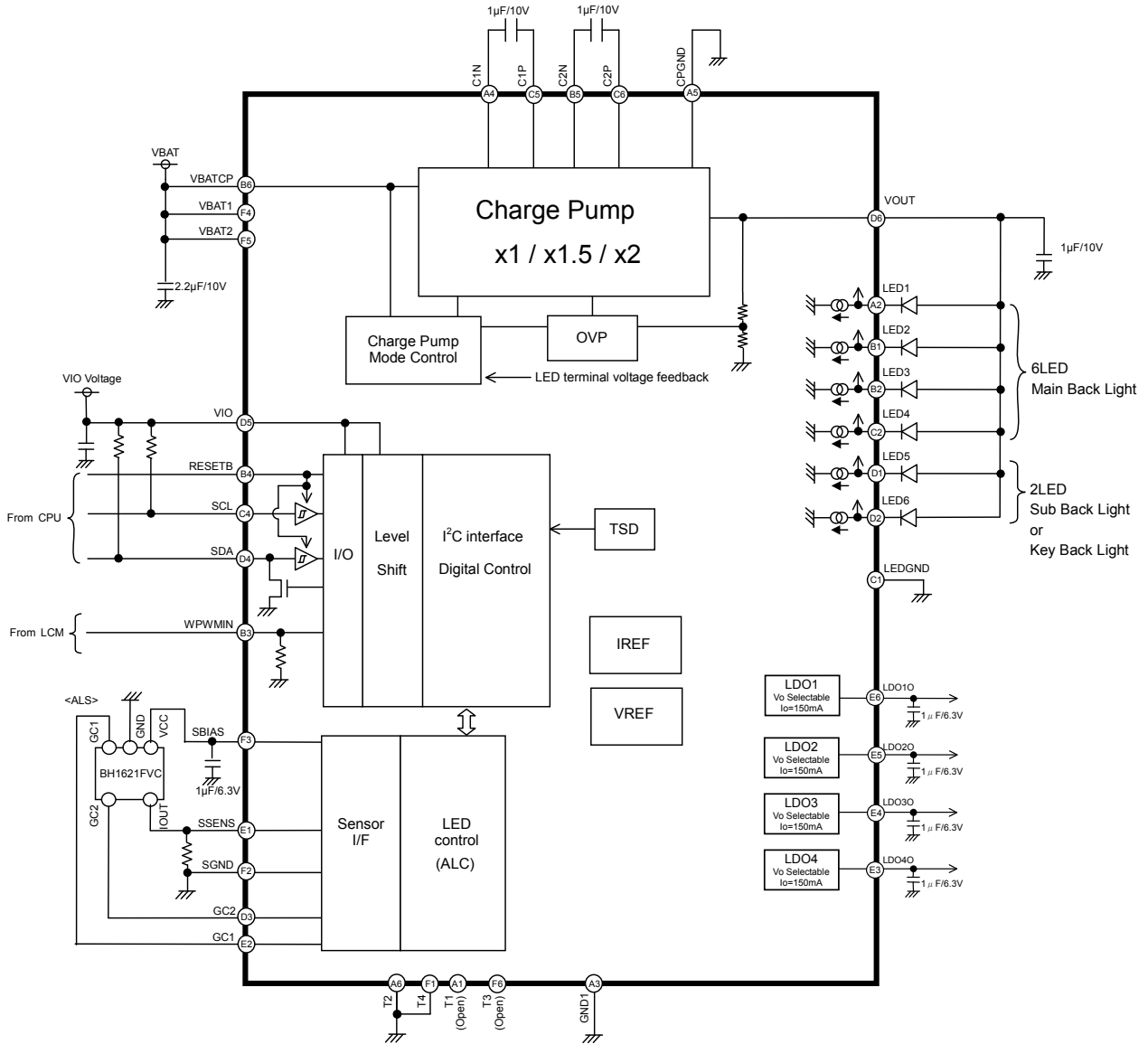



Fig.4 Block Diagram / Application Circuit Example 3

●Pin Arrangement [Bottom View]

F	T4	SGND	SBIAS	VBAT1	VBAT2	T3
E	SSENS	GC1	LDO40	LDO30	LDO20	LDO10
D	LED5	LED6	GC2	SDA	VIO	VOUT
C	LEDGND	LED4	index 	SCL	C1P	C2P
B	LED2	LED3	WPWMIN	RESETB	C2N	VBATCP
A	T1	LED1	GND1	C1N	CPGND	T2
	1	2	3	4	5	6

Total 35 Ball

Fig.5 Pin Arrangement

●Package Outline

- VCSP50L3 CSP small package
- SIZE : 3.15mm x 3.15mm (A difference in public:X,Y Both $\pm 0.05\text{mm}$)
- Height : 0.55mm max
- A ball pitch : 0.5 mm

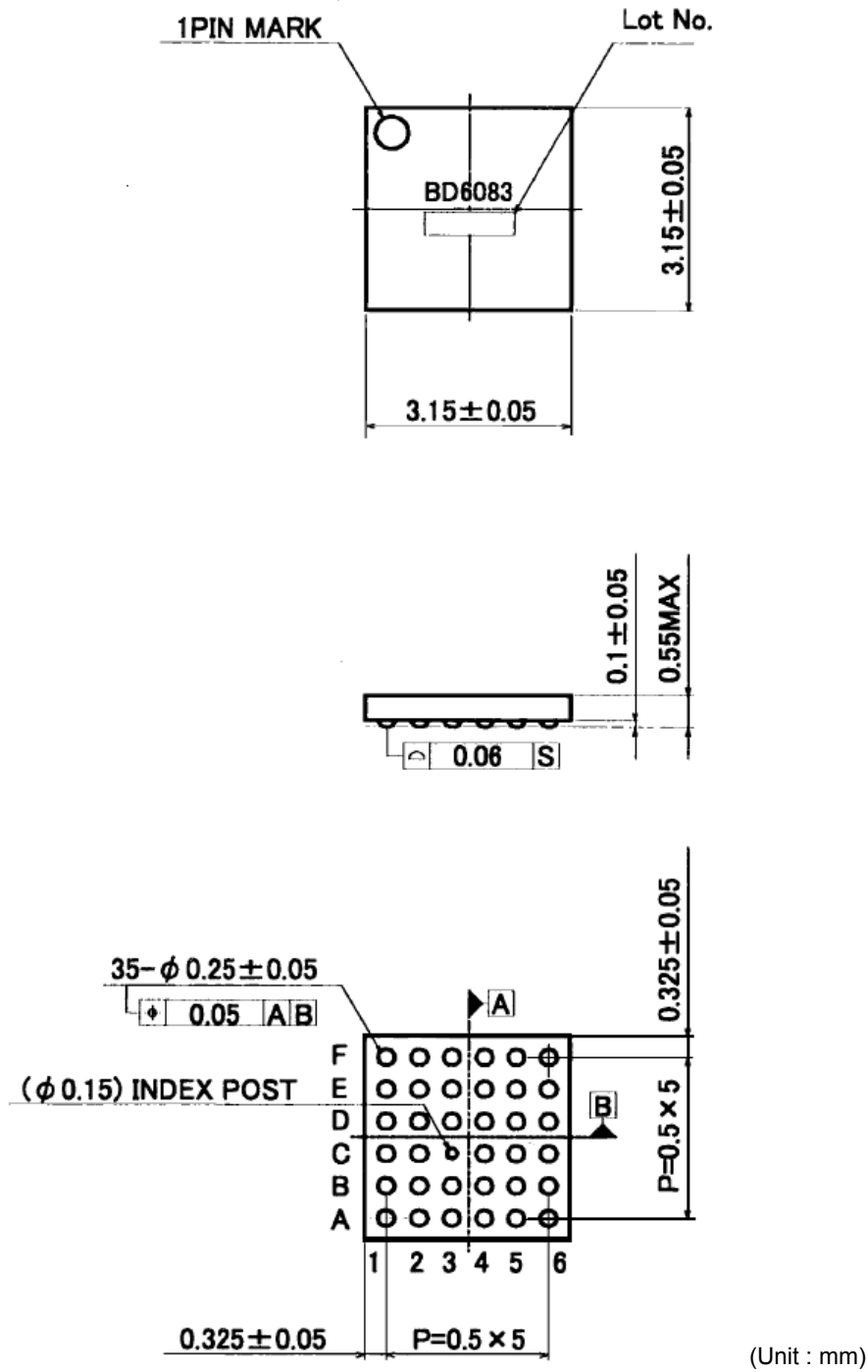

Fig.6 Package Outline

●Pin Functions

No	Ball No.	Pin Name	I/O	ESD Diode		Functions	Equivalent Circuit
				For Power	For Ground		
1	B6	VBATCP	-	-	GND	Battery is connected	A
2	F4	VBAT1	-	-	GND	Battery is connected	A
3	F5	VBAT2	-	-	GND	Battery is connected	A
4	A1	T1	O	VBAT	GND	Test Output Pin(Open)	N
5	A6	T2	I	VBAT	GND	Test Input Pin (short to Ground)	S
6	F6	T3	O	VBAT	GND	Test Output Pin(Open)	M
7	F1	T4	I	VBAT	GND	Test Input Pin (short to Ground)	S
8	D5	VIO	-	VBAT	GND	I/O Power supply is connected	C
9	B4	RESETB	I	VBAT	GND	Reset input (L: reset, H: reset cancel)	H
10	D4	SDA	I/O	VBAT	GND	I ² C data input / output	I
11	C4	SCL	I	VBAT	GND	I ² C clock input	H
12	A5	CPGND	-	VBAT	-	Ground	B
13	A3	GND1	-	VBAT	-	Ground	B
14	C1	LEDGND	-	VBAT	-	Ground	B
15	A4	C1N	I/O	VBAT	GND	Charge Pump capacitor is connected	F
16	C5	C1P	I/O	-	GND	Charge Pump capacitor is connected	G
17	B5	C2N	I/O	VBAT	GND	Charge Pump capacitor is connected	F
18	C6	C2P	I/O	-	GND	Charge Pump capacitor is connected	G
19	D6	VOOUT	O	-	GND	Charge Pump output pin	A
20	A2	LED1	I	-	GND	LED is connected 1 for LCD Back Light	E
21	B1	LED2	I	-	GND	LED is connected 2 for LCD Back Light	E
22	B2	LED3	I	-	GND	LED is connected 3 for LCD Back Light	E
23	C2	LED4	I	-	GND	LED is connected 4 for LCD Back Light	E
24	D1	LED5	I	-	GND	LED is connected 5 for LCD Back Light	E
25	D2	LED6	I	-	GND	LED is connected 6 for LCD Back Light	E
26	F3	SBIAS	O	VBAT	GND	Bias output for the Ambient Light Sensor	Q
27	E1	SSENS	I	VBAT	GND	Ambient Light Sensor input	N
28	E2	GC1	O	VBAT	GND	Ambient Light Sensor gain control output 1	X
29	D3	GC2	O	VBAT	GND	Ambient Light Sensor gain control output 2	X
30	F2	SGND	-	VBAT	-	Ground	B
31	B3	WPWMIN	I	VBAT	GND	External PWM input for Back Light *	L
32	E6	LDO1O	O	VBAT	GND	LDO1 output pin	Q
33	E5	LDO2O	O	VBAT	GND	LDO2 output pin	Q
34	E4	LDO3O	O	VBAT	GND	LDO3 output pin	Q
35	E3	LDO4O	O	VBAT	GND	LDO4 output pin	Q

* A setup of a register is separately necessary to make it effective.

●Equivalent Circuit

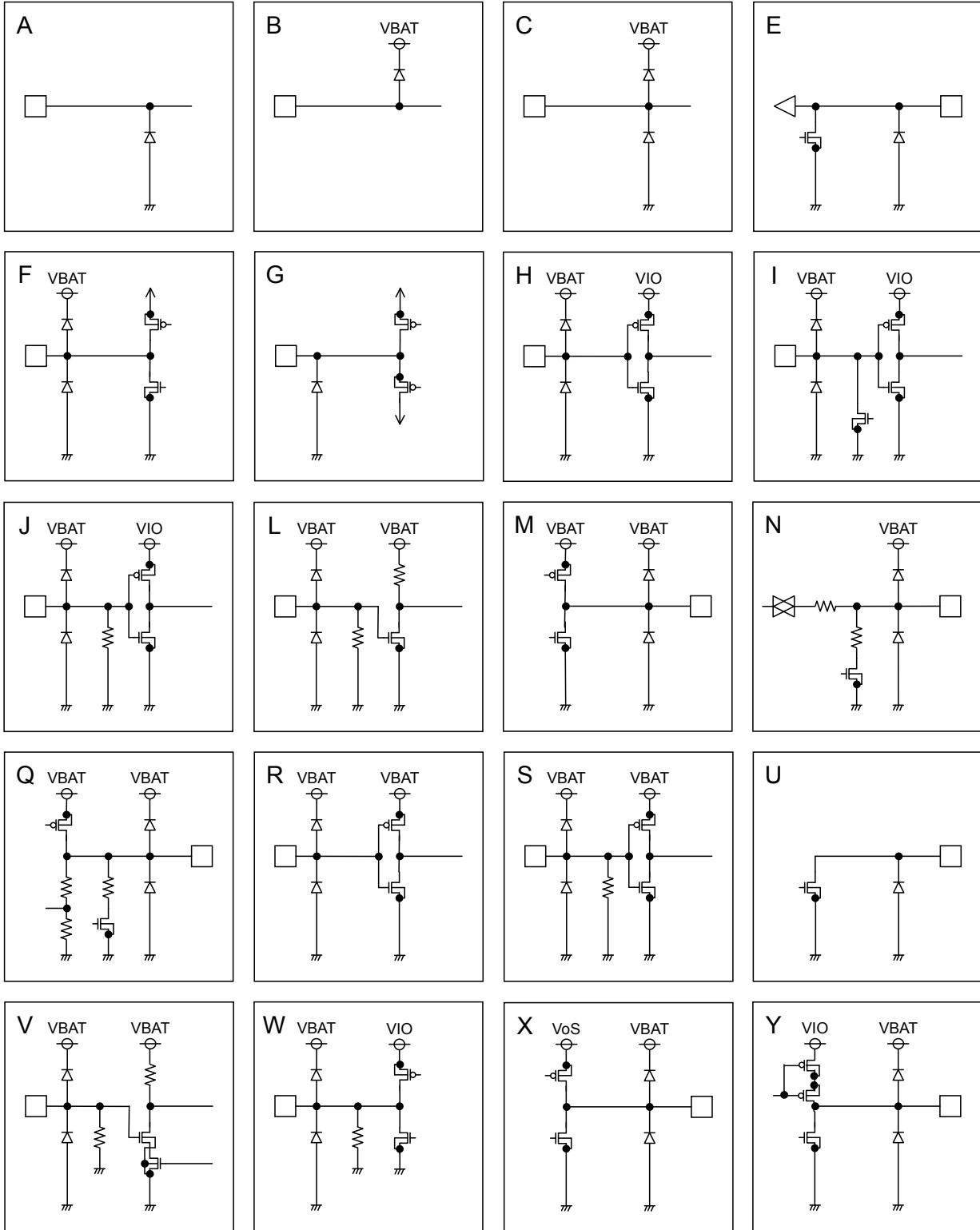

Fig.7 Equivalent Circuit

● I²C BUS Format

The writing/reading operation is based on the I²C slave standard.

- Slave address

A7	A6	A5	A4	A3	A2	A1	R/W
1	1	1	0	1	1	0	1/0

- Bit Transfer

SCL transfers 1-bit data during H. SCL cannot change signal of SDA during H at the time of bit transfer. If SDA changes while SCL is H, START conditions or STOP conditions will occur and it will be interpreted as a control signal.

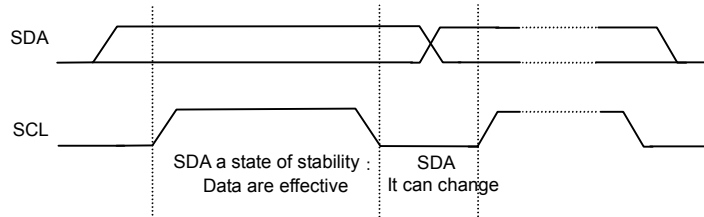

Fig.8

- START and STOP condition

When SDA and SCL are H, data is not transferred on the I²C- bus. This condition indicates, if SDA changes from H to L while SCL has been H, it will become START (S) conditions, and an access start, if SDA changes from L to H while SCL has been H, it will become STOP (P) conditions and an access end.

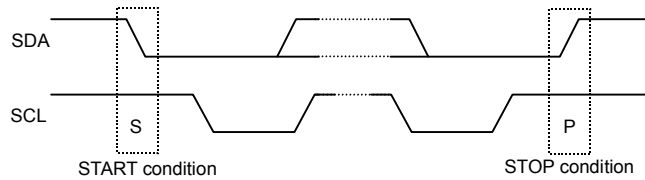

Fig.9

- Acknowledge

It transfers data 8 bits each after the occurrence of START condition. A transmitter opens SDA after transfer 8bits data, and a receiver returns the acknowledge signal by setting SDA to L.

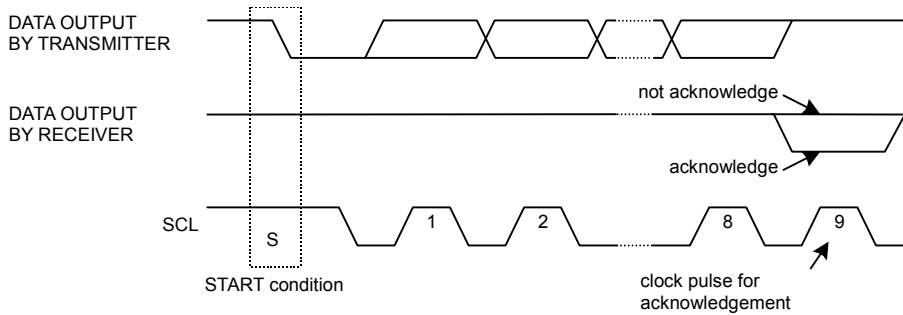

Fig.10

• Writing protocol

A register address is transferred by the next 1 byte that transferred the slave address and the write-in command. The 3rd byte writes data in the internal register written in by the 2nd byte, and after 4th byte or, the increment of register address is carried out automatically. However, when a register address turns into the last address, it is set to 00h by the next transmission. After the transmission end, the increment of the address is carried out.

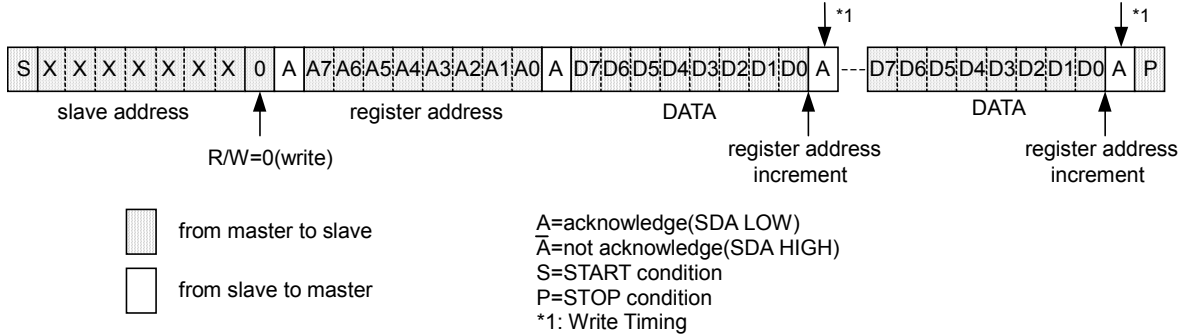

Fig.11

• Reading protocol

It reads from the next byte after writing a slave address and R/W bit. The register to read considers as the following address accessed at the end, and the data of the address that carried out the increment is read after it. If an address turns into the last address, the next byte will read out 00h. After the transmission end, the increment of the address is carried out.

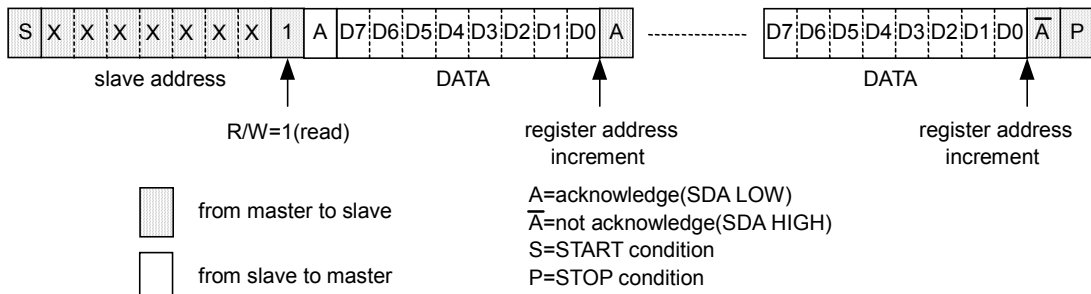

Fig.12

• Multiple reading protocols

After specifying an internal address, it reads by repeated START condition and changing the data transfer direction. The data of the address that carried out the increment is read after it. If an address turns into the last address, the next byte will read out 00h. After the transmission end, the increment of the address is carried out.

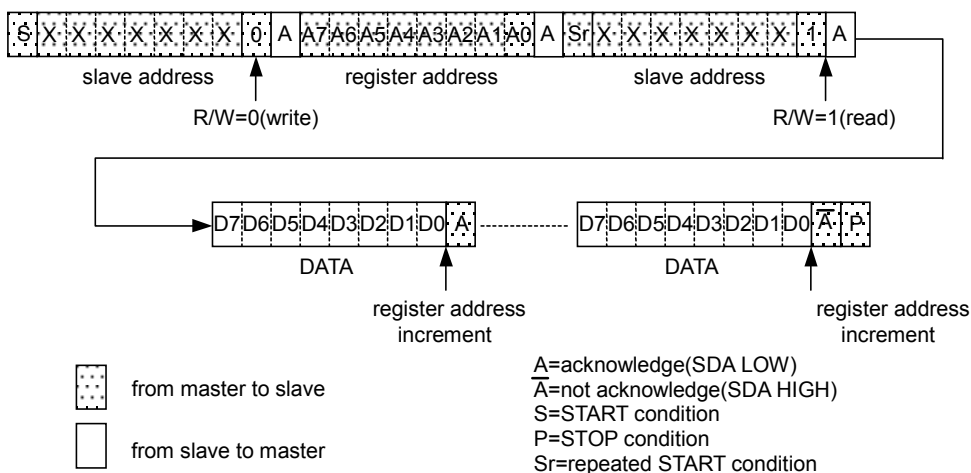

Fig.13

As for reading protocol and multiple reading protocols, please do A-bar (not acknowledge) after doing the final reading operation. It stops with read when ending by A (acknowledge), and SDA stops in the state of Low when the reading data of that time is 0. However, this state returns usually when SCL is moved, data is read, and A-bar (not acknowledge) is done.

●Timing Diagram

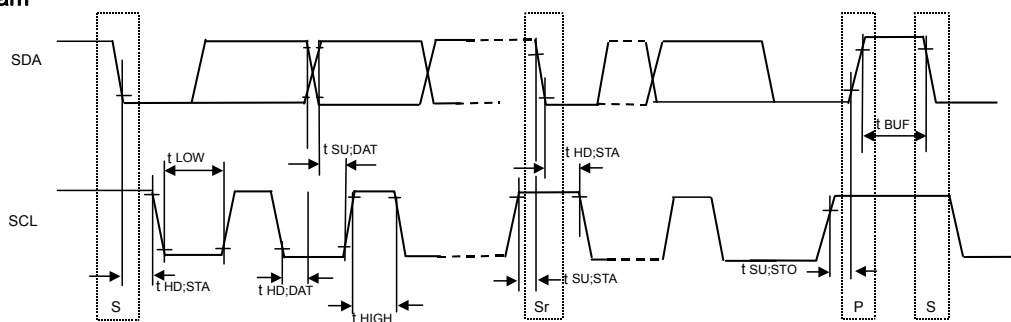

Fig.14

●Electrical Characteristics(Unless otherwise specified, Ta=25 °C, VBAT=3.6V, VIO=1.8V)

Parameter	Symbol	Standard-mode			Fast-mode			Unit
		Min.	Typ.	Max.	Min.	Typ.	Max.	
【I²C BUS format】								
SCL clock frequency	fSCL	0	-	100	0	-	400	kHz
LOW period of the SCL clock	tLOW	4.7	-	-	1.3	-	-	μs
HIGH period of the SCL clock	tHIGH	4.0	-	-	0.6	-	-	μs
Hold time (repeated) START condition After this period, the first clock is generated	tHD;STA	4.0	-	-	0.6	-	-	μs
Set-up time for a repeated START condition	tSU;STA	4.7	-	-	0.6	-	-	μs
Data hold time	tHD;DAT	0	-	3.45	0	-	0.9	μs
Data set-up time	tSU;DAT	250	-	-	100	-	-	ns
Set-up time for STOP condition	tSU;STO	4.0	-	-	0.6	-	-	μs
Bus free time between a STOP and START condition	tBUF	4.7	-	-	1.3	-	-	μs

●Register List

Address	W/R	Register data								Function
		D7	D6	D5	D4	D3	D2	D1	D0	
00h	W	-	-	-	-	-	-	-	SFTRST	Software Reset
01h	W	-	-	-	-	W6MD	W5MD	W4MD	MLEDMD	LED Pin function setting
02h	W	WPWMEN	ALCEN	-	-	W6EN	W5EN	-	MLEDEN	LED Power Control
03h	W	-	IMLED(6)	IMLED(5)	IMLED(4)	IMLED(3)	IMLED(2)	IMLED(1)	IMLED(0)	Main group current setting
04h	-	-	-	-	-	-	-	-	-	-
05h	W	-	IW5(6)	IW5(5)	IW5(4)	IW5(3)	IW5(2)	IW5(1)	IW5(0)	LED5 current setting
06h	W	-	IW6(6)	IW6(5)	IW6(4)	IW6(3)	IW6(2)	IW6(1)	IW6(0)	LED6 current setting
07h	-	-	-	-	-	-	-	-	-	-
08h	-	-	-	-	-	-	-	-	-	-
09h	W	THL (3)	THL (2)	THL (1)	THL (0)	TLH (3)	TLH (2)	TLH (1)	TLH (0)	Main Current transition
0Ah	W	-	ADCYC	-	GAIN	-	-	MDCIR	SBIASON	Measurement mode setting
0Bh	W	-	-	-	-	CRV	STEP (2)	STEP (1)	STEP (0)	ALC Slope curve setup
0Ch	R	-	-	-	-	AMB (3)	AMB (2)	AMB (1)	AMB (0)	Ambient level
0Dh	W	-	IU0 (6)	IU0 (5)	IU0 (4)	IU0 (3)	IU0 (2)	IU0 (1)	IU0 (0)	LED Current at Ambient level 0h (ALC)
0Eh	W	-	IU1 (6)	IU1 (5)	IU1 (4)	IU1 (3)	IU1 (2)	IU1 (1)	IU1 (0)	LED Current max (ALC)
0Fh	-	-	-	-	-	-	-	-	-	-
10h	-	-	-	-	-	-	-	-	-	-
11h	-	-	-	-	-	-	-	-	-	-
12h	-	-	-	-	-	-	-	-	-	-
13h	W	-	-	-	-	LDO4EN	LDO3EN	LDO2EN	LDO1EN	LDO Power Control
14h	W	LDO2VSEL3	LDO2VSEL2	LDO2VSEL1	LDO2VSEL0	LDO1VSEL3	LDO1VSEL2	LDO1VSEL1	LDO1VSEL0	LDO1 Vout Control LDO2 Vout Control
15h	W	LDO4VSEL3	LDO4VSEL2	LDO4VSEL1	LDO4VSEL0	LDO3VSEL3	LDO3VSEL2	LDO3VSEL1	LDO3VSEL0	LDO3 Vout Control LDO4 Vout Control

Input "0" for "-".

A free address has the possibility to assign it to the register for the test.

Access to the register for the test and the undefined register is prohibited.

●Register Map

Address 00h < Software Reset >

Address	R/W	Bit7	Bit6	Bit5	Bit4	Bit3	Bit2	Bit1	Bit0
00h	W	-	-	-	-	-	-	-	SFTRST
Initial Value	00h	-	-	-	-	-	-	-	0

Bit[7:1] : (Not used)

Bit0 : **SFTRST** Software Reset
 "0" : Reset cancel
 "1" : Reset(All register initializing)
 Refer to "Reset" for detail.

Address 01h < LED Pin function setting>

Address	R/W	Bit7	Bit6	Bit5	Bit4	Bit3	Bit2	Bit1	Bit0
01h	W	-	-	-	-	W6MD	W5MD	W4MD	MLEDMD
Initial Value	02h	-	-	-	-	0	0	1	0

Bit[7:4] : (Not used)

Bit3 : **W6MD** LED6 control setting (individual / Main group)
 "0" : LED6 individual control (Initial Value)
 "1" : LED6 Main group control
 Refer to "LED Driver" for detail.

Bit2 : **W5MD** LED5 control setting (individual / Main group)
 "0" : LED5 individual control (Initial Value)
 "1" : LED5 Main group control
 Refer to "LED Driver" for detail.

Bit1 : **W4MD** LED4 Control Board setting (unuse / use)
 "0" : LED4 unuse
 "1" : LED4 use (Main group Control) (Initial Value)
 Refer to "LED Driver" for detail.

Bit0 : **MLEDMD** Main group setting (Normal / ALC)
 "0" : Main group Normal Mode(ALCNon-reflection)(Initial Value)
 "1" : Main group ALC Mode
 Refer to "(1) Auto Luminous Control ON/OFF" of "ALC" for detail.

Set up a fixation in every design because it isn't presumed W*PW that it is changed dynamically.
 And, do the setup of W*PW when each LED is Off.

Address 02h < LED Power Control >

Address	R/W	Bit7	Bit6	Bit5	Bit4	Bit3	Bit2	Bit1	Bit0
02h	W	WPWMEN	ALCEN	-	-	W6EN	W5EN	-	MLEDEN
Initial Value	00h	0	0	0	0	0	0	0	0

Bit7 : **WPWMEN** External PWM Input "WPWMIN" terminal Enable Control (Valid/Invalid)

"0" : External PWM input invalid (Initial Value)

"1" : External PWM input valid

Refer to "(10) Current Adjustment" of "ALC" for detail.

Bit6 : **ALCEN** ALC function Control (ON/OFF)

"0" : ALC block OFF (Initial Value)

"1" : ALC block ON (Ambient Measurement)

Refer to "(1) Auto Luminous Control ON/OFF" of "ALC" for detail.

Bit[5:4] : (Not used)

Bit3 : **W6EN** LED6 Control (ON/OFF)

"0" : LED6 OFF (Initial Value)

"1" : LED6 ON(individual control)

Refer to "LED Driver" for detail.

Bit2 : **W5EN** LED5 Control (ON/OFF)

"0" : LED5 OFF (Initial Value)

"1" : LED5 ON(individual control)

Refer to "LED Driver" for detail.

Bit1 : (Not used)

Bit0 : **MLEDEN** Main group LED Control (ON/OFF)

"0" : Main group OFF (Initial Value)

"1" : Main group ON

Refer to "(1) Auto Luminous Control ON/OFF" of "ALC" for detail.

Address 03h < Main group LED Current setting(Normal Mode) >

Address	R/W	Bit7	Bit6	Bit5	Bit4	Bit3	Bit2	Bit1	Bit0
03h	W	-	IMLED(6)	IMLED(5)	IMLED(4)	IMLED(3)	IMLED(2)	IMLED(1)	IMLED(0)
Initial Value	00h	-	0	0	0	0	0	0	0

Bit7 : (Not used)

Bit[6:0] : **IMLED (6:0)** Main Group LED Current Setting at non-ALC mode

"0000000" : 0.2 mA (Initial Value)	"1000000" : 13.0 mA
"0000001" : 0.4 mA	"1000001" : 13.2 mA
"0000010" : 0.6 mA	"1000010" : 13.4 mA
"0000011" : 0.8 mA	"1000011" : 13.6 mA
"0000100" : 1.0 mA	"1000100" : 13.8 mA
"0000101" : 1.2 mA	"1000101" : 14.0 mA
"0000110" : 1.4 mA	"1000110" : 14.2 mA
"0000111" : 1.6 mA	"1000111" : 14.4 mA
"0001000" : 1.8 mA	"1001000" : 14.6 mA
"0001001" : 2.0 mA	"1001001" : 14.8 mA
"0001010" : 2.2 mA	"1001010" : 15.0 mA
"0001011" : 2.4 mA	"1001011" : 15.2 mA
"0001100" : 2.6 mA	"1001100" : 15.4 mA
"0001101" : 2.8 mA	"1001101" : 15.6 mA
"0001110" : 3.0 mA	"1001110" : 15.8 mA
"0001111" : 3.2 mA	"1001111" : 16.0 mA
"0010000" : 3.4 mA	"1010000" : 16.2 mA
"0010001" : 3.6 mA	"1010001" : 16.4 mA
"0010010" : 3.8 mA	"1010010" : 16.6 mA
"0010011" : 4.0 mA	"1010011" : 16.8 mA
"0010100" : 4.2 mA	"1010100" : 17.0 mA
"0010101" : 4.4 mA	"1010101" : 17.2 mA
"0010110" : 4.6 mA	"1010110" : 17.4 mA
"0010111" : 4.8 mA	"1010111" : 17.6 mA
"0011000" : 5.0 mA	"1011000" : 17.8 mA
"0011001" : 5.2 mA	"1011001" : 18.0 mA
"0011010" : 5.4 mA	"1011010" : 18.2 mA
"0011011" : 5.6 mA	"1011011" : 18.4 mA
"0011100" : 5.8 mA	"1011100" : 18.6 mA
"0011101" : 6.0 mA	"1011101" : 18.8 mA
"0011110" : 6.2 mA	"1011110" : 19.0 mA
"0011111" : 6.4 mA	"1011111" : 19.2 mA
"0100000" : 6.6 mA	"1100000" : 19.4 mA
"0100001" : 6.8 mA	"1100001" : 19.6 mA
"0100010" : 7.0 mA	"1100010" : 19.8 mA
"0100011" : 7.2 mA	"1100011" : 20.0 mA
"0100100" : 7.4 mA	"1100100" : 20.2 mA
"0100101" : 7.6 mA	"1100101" : 20.4 mA
"0100110" : 7.8 mA	"1100110" : 20.6 mA
"0100111" : 8.0 mA	"1100111" : 20.8 mA
"0101000" : 8.2 mA	"1101000" : 21.0 mA
"0101001" : 8.4 mA	"1101001" : 21.2 mA
"0101010" : 8.6 mA	"1101010" : 21.4 mA
"0101011" : 8.8 mA	"1101011" : 21.6 mA
"0101100" : 9.0 mA	"1101100" : 21.8 mA
"0101101" : 9.2 mA	"1101101" : 22.0 mA
"0101110" : 9.4 mA	"1101110" : 22.2 mA
"0101111" : 9.6 mA	"1101111" : 22.4 mA
"0110000" : 9.8 mA	"1110000" : 22.6 mA
"0110001" : 10.0 mA	"1110001" : 22.8 mA
"0110010" : 10.2 mA	"1110010" : 23.0 mA
"0110011" : 10.4 mA	"1110011" : 23.2 mA
"0110100" : 10.6 mA	"1110100" : 23.4 mA
"0110101" : 10.8 mA	"1110101" : 23.6 mA
"0110110" : 11.0 mA	"1110110" : 23.8 mA
"0110111" : 11.2 mA	"1110111" : 24.0 mA
"0111000" : 11.4 mA	"1111000" : 24.2 mA
"0111001" : 11.6 mA	"1111001" : 24.4 mA
"0111010" : 11.8 mA	"1111010" : 24.6 mA
"0111011" : 12.0 mA	"1111011" : 24.8 mA
"0111100" : 12.2 mA	"1111100" : 25.0 mA
"0111101" : 12.4 mA	"1111101" : 25.2 mA
"0111110" : 12.6 mA	"1111110" : 25.4 mA
"0111111" : 12.8 mA	"1111111" : 25.6 mA

Address 05h < LED5 Current setting(Independence control) >

Address	R/W	Bit7	Bit6	Bit5	Bit4	Bit3	Bit2	Bit1	Bit0
05h	W	-	IW5(6)	IW5(5)	IW5(4)	IW5(3)	IW5(2)	IW5(1)	IW5(0)
Initial Value	00h	-	0	0	0	0	0	0	0

Bit7 : (Not used)

Bit[6:0] : IW5 (6:0) LED5 Current setting

"0000000" : 0.2 mA (Initial Value)	"1000000" : 13.0 mA
"0000001" : 0.4 mA	"1000001" : 13.2 mA
"0000010" : 0.6 mA	"1000010" : 13.4 mA
"0000011" : 0.8 mA	"1000011" : 13.6 mA
"0000100" : 1.0 mA	"1000100" : 13.8 mA
"0000101" : 1.2 mA	"1000101" : 14.0 mA
"0000110" : 1.4 mA	"1000110" : 14.2 mA
"0000111" : 1.6 mA	"1000111" : 14.4 mA
"0001000" : 1.8 mA	"1001000" : 14.6 mA
"0001001" : 2.0 mA	"1001001" : 14.8 mA
"0001010" : 2.2 mA	"1001010" : 15.0 mA
"0001011" : 2.4 mA	"1001011" : 15.2 mA
"0001100" : 2.6 mA	"1001100" : 15.4 mA
"0001101" : 2.8 mA	"1001101" : 15.6 mA
"0001110" : 3.0 mA	"1001110" : 15.8 mA
"0001111" : 3.2 mA	"1001111" : 16.0 mA
"0010000" : 3.4 mA	"1010000" : 16.2 mA
"0010001" : 3.6 mA	"1010001" : 16.4 mA
"0010010" : 3.8 mA	"1010010" : 16.6 mA
"0010011" : 4.0 mA	"1010011" : 16.8 mA
"0010100" : 4.2 mA	"1010100" : 17.0 mA
"0010101" : 4.4 mA	"1010101" : 17.2 mA
"0010110" : 4.6 mA	"1010110" : 17.4 mA
"0010111" : 4.8 mA	"1010111" : 17.6 mA
"0011000" : 5.0 mA	"1011000" : 17.8 mA
"0011001" : 5.2 mA	"1011001" : 18.0 mA
"0011010" : 5.4 mA	"1011010" : 18.2 mA
"0011011" : 5.6 mA	"1011011" : 18.4 mA
"0011100" : 5.8 mA	"1011100" : 18.6 mA
"0011101" : 6.0 mA	"1011101" : 18.8 mA
"0011110" : 6.2 mA	"1011110" : 19.0 mA
"0011111" : 6.4 mA	"1011111" : 19.2 mA
"0100000" : 6.6 mA	"1100000" : 19.4 mA
"0100001" : 6.8 mA	"1100001" : 19.6 mA
"0100010" : 7.0 mA	"1100010" : 19.8 mA
"0100011" : 7.2 mA	"1100011" : 20.0 mA
"0100100" : 7.4 mA	"1100100" : 20.2 mA
"0100101" : 7.6 mA	"1100101" : 20.4 mA
"0100110" : 7.8 mA	"1100110" : 20.6 mA
"0100111" : 8.0 mA	"1100111" : 20.8 mA
"0101000" : 8.2 mA	"1101000" : 21.0 mA
"0101001" : 8.4 mA	"1101001" : 21.2 mA
"0101010" : 8.6 mA	"1101010" : 21.4 mA
"0101011" : 8.8 mA	"1101011" : 21.6 mA
"0101100" : 9.0 mA	"1101100" : 21.8 mA
"0101101" : 9.2 mA	"1101101" : 22.0 mA
"0101110" : 9.4 mA	"1101110" : 22.2 mA
"0101111" : 9.6 mA	"1101111" : 22.4 mA
"0110000" : 9.8 mA	"1110000" : 22.6 mA
"0110001" : 10.0 mA	"1110001" : 22.8 mA
"0110010" : 10.2 mA	"1110010" : 23.0 mA
"0110011" : 10.4 mA	"1110011" : 23.2 mA
"0110100" : 10.6 mA	"1110100" : 23.4 mA
"0110101" : 10.8 mA	"1110101" : 23.6 mA
"0110110" : 11.0 mA	"1110110" : 23.8 mA
"0110111" : 11.2 mA	"1110111" : 24.0 mA
"0111000" : 11.4 mA	"1111000" : 24.2 mA
"0111001" : 11.6 mA	"1111001" : 24.4 mA
"0111010" : 11.8 mA	"1111010" : 24.6 mA
"0111011" : 12.0 mA	"1111011" : 24.8 mA
"0111100" : 12.2 mA	"1111100" : 25.0 mA
"0111101" : 12.4 mA	"1111101" : 25.2 mA
"0111110" : 12.6 mA	"1111110" : 25.4 mA
"0111111" : 12.8 mA	"1111111" : 25.6 mA

Address 06h < LED6 Current setting(Independence control) >

Address	R/W	Bit7	Bit6	Bit5	Bit4	Bit3	Bit2	Bit1	Bit0
06h	W	-	IW6(6)	IW6(5)	IW6(4)	IW6(3)	IW6(2)	IW6(1)	IW6(0)
Initial Value	00h	-	0	0	0	0	0	0	0

Bit7 : (Not used)

Bit[6:0] : IW6 (6:0) LED6 Current setting

"0000000" : 0.2 mA (Initial Value)	"1000000" : 13.0 mA
"0000001" : 0.4 mA	"1000001" : 13.2 mA
"0000010" : 0.6 mA	"1000010" : 13.4 mA
"0000011" : 0.8 mA	"1000011" : 13.6 mA
"0000100" : 1.0 mA	"1000100" : 13.8 mA
"0000101" : 1.2 mA	"1000101" : 14.0 mA
"0000110" : 1.4 mA	"1000110" : 14.2 mA
"0000111" : 1.6 mA	"1000111" : 14.4 mA
"0001000" : 1.8 mA	"1001000" : 14.6 mA
"0001001" : 2.0 mA	"1001001" : 14.8 mA
"0001010" : 2.2 mA	"1001010" : 15.0 mA
"0001011" : 2.4 mA	"1001011" : 15.2 mA
"0001100" : 2.6 mA	"1001100" : 15.4 mA
"0001101" : 2.8 mA	"1001101" : 15.6 mA
"0001110" : 3.0 mA	"1001110" : 15.8 mA
"0001111" : 3.2 mA	"1001111" : 16.0 mA
"0010000" : 3.4 mA	"1010000" : 16.2 mA
"0010001" : 3.6 mA	"1010001" : 16.4 mA
"0010010" : 3.8 mA	"1010010" : 16.6 mA
"0010011" : 4.0 mA	"1010011" : 16.8 mA
"0010100" : 4.2 mA	"1010100" : 17.0 mA
"0010101" : 4.4 mA	"1010101" : 17.2 mA
"0010110" : 4.6 mA	"1010110" : 17.4 mA
"0010111" : 4.8 mA	"1010111" : 17.6 mA
"0011000" : 5.0 mA	"1011000" : 17.8 mA
"0011001" : 5.2 mA	"1011001" : 18.0 mA
"0011010" : 5.4 mA	"1011010" : 18.2 mA
"0011011" : 5.6 mA	"1011011" : 18.4 mA
"0011100" : 5.8 mA	"1011100" : 18.6 mA
"0011101" : 6.0 mA	"1011101" : 18.8 mA
"0011110" : 6.2 mA	"1011110" : 19.0 mA
"0011111" : 6.4 mA	"1011111" : 19.2 mA
"0100000" : 6.6 mA	"1100000" : 19.4 mA
"0100001" : 6.8 mA	"1100001" : 19.6 mA
"0100010" : 7.0 mA	"1100010" : 19.8 mA
"0100011" : 7.2 mA	"1100011" : 20.0 mA
"0100100" : 7.4 mA	"1100100" : 20.2 mA
"0100101" : 7.6 mA	"1100101" : 20.4 mA
"0100110" : 7.8 mA	"1100110" : 20.6 mA
"0100111" : 8.0 mA	"1100111" : 20.8 mA
"0101000" : 8.2 mA	"1101000" : 21.0 mA
"0101001" : 8.4 mA	"1101001" : 21.2 mA
"0101010" : 8.6 mA	"1101010" : 21.4 mA
"0101011" : 8.8 mA	"1101011" : 21.6 mA
"0101100" : 9.0 mA	"1101100" : 21.8 mA
"0101101" : 9.2 mA	"1101101" : 22.0 mA
"0101110" : 9.4 mA	"1101110" : 22.2 mA
"0101111" : 9.6 mA	"1101111" : 22.4 mA
"0110000" : 9.8 mA	"1110000" : 22.6 mA
"0110001" : 10.0 mA	"1110001" : 22.8 mA
"0110010" : 10.2 mA	"1110010" : 23.0 mA
"0110011" : 10.4 mA	"1110011" : 23.2 mA
"0110100" : 10.6 mA	"1110100" : 23.4 mA
"0110101" : 10.8 mA	"1110101" : 23.6 mA
"0110110" : 11.0 mA	"1110110" : 23.8 mA
"0110111" : 11.2 mA	"1110111" : 24.0 mA
"0111000" : 11.4 mA	"1111000" : 24.2 mA
"0111001" : 11.6 mA	"1111001" : 24.4 mA
"0111010" : 11.8 mA	"1111010" : 24.6 mA
"0111011" : 12.0 mA	"1111011" : 24.8 mA
"0111100" : 12.2 mA	"1111100" : 25.0 mA
"0111101" : 12.4 mA	"1111101" : 25.2 mA
"0111110" : 12.6 mA	"1111110" : 25.4 mA
"0111111" : 12.8 mA	"1111111" : 25.6 mA

Address 09h < Main Current slope time setting >

Address	R/W	Bit7	Bit6	Bit5	Bit4	Bit3	Bit2	Bit1	Bit0
09h	W	THL(3)	THL(2)	THL(1)	THL(0)	TLH(3)	TLH(2)	TLH(1)	TLH(0)
Initial Value	C7h	1	1	0	0	0	1	1	1

Bit[7:4] : **THL (3:0)** Main LED current Down transition per 0.2mA step

"0000" :	0.256 ms
"0001" :	0.512 ms
"0010" :	1.024 ms
"0011" :	2.048 ms
"0100" :	4.096 ms
"0101" :	8.192 ms
"0110" :	16.38 ms
"0111" :	32.77 ms
"1000" :	65.54 ms
"1001" :	131.1 ms
"1010" :	196.6 ms
"1011" :	262.1 ms
"1100" :	327.7 ms (Initial Value)
"1101" :	393.2 ms
"1110" :	458.8 ms
"1111" :	524.3 ms

Setting time is counted based on the switching frequency of Charge Pump.

The above value becomes the value of the Typ (1MHz) time.

Refer to "(8) Slope Process" of "ALC" for detail.

Bit[3:0] : **TLH (3:0)** Main LED current Up transition per 0.2mA step

"0000" :	0.256 ms
"0001" :	0.512 ms
"0010" :	1.024 ms
"0011" :	2.048 ms
"0100" :	4.096 ms
"0101" :	8.192 ms
"0110" :	16.38 ms
"0111" :	32.77 ms (Initial Value)
"1000" :	65.54 ms
"1001" :	131.1 ms
"1010" :	196.6 ms
"1011" :	262.1 ms
"1100" :	327.7 ms
"1101" :	393.2 ms
"1110" :	458.8 ms
"1111" :	524.3 ms

Setting time is counted based on the switching frequency of Charge Pump.

The above value becomes the value of the Typ (1MHz) time.

Refer to "(8) Slope Process" of "ALC" for detail.

Address 0Ah < ALC mode setting >

Address	R/W	Bit7	Bit6	Bit5	Bit4	Bit3	Bit2	Bit1	Bit0
0Ah	W	-	ADCYC	-	GAIN	-	-	MDCIR	SBIASON
Initial Value	01h	-	0	-	0	-	-	0	1

Bit7 : (Not used)

Bit6 : **ADCYC** ADC Measurement Cycle
 "0" : 0.52 s (Initial Value)
 "1" : 1.05 s
 Refer to "(4) A/D conversion" of "ALC" for detail.

Bit5 : (Not used)

Bit4 : **GAIN** Sensor Gain Switching Function Control
 "0" : Auto Change (Initial Value)
 "1" : Fixed
 Refer to "(3) Gain control" of "ALC" for detail.

Bit[3:2] : (Not used)

Bit1 : **MDCIR** LED Current Reset Select by Mode Change
 "0" : LED current non-reset when mode change (Initial Value)
 "1" : LED current reset when mode change
 Refer to "(9) LED current reset when mode change" of "ALC" for detail.

Bit0 : **SBIASON**
 "0" : Measurement cycle synchronous
 "1" : Usually ON (at ALCEN=1) (Initial Value)
 Refer to "(4) A/D conversion" of "ALC" for detail.

Address 0Bh < ALC slope curve setting >

Address	R/W	Bit7	Bit6	Bit5	Bit4	Bit3	Bit2	Bit1	Bit0
0Bh	W	-	-	-	-	CRV	STEP (2)	STEP (1)	STEP (0)
Initial Value	00h	-	-	-	-	0	0	0	1

Bit[7:4] : (Not used)

Bit3 : **CRV** Brightness Current Conversion Curve Type
 "0" : Log curve (Initial Value)
 "1" : linear

Bit[2:0] : **STEP (2:0)** Step At the time of Brightness Current Conversion
 "000" : 1.0mA
 "001" : 1.1mA (Initial Value)
 "010" : 1.2mA
 "011" : 1.3mA
 "100" : 1.6mA
 "101" : 1.7mA
 "110" : 1.8mA
 "111" : 1.9mA

Refer to "(7) Convert LED Current" of "ALC" for detail.

Address 0Ch < Ambient level (Read Only) >

Address	R/W	Bit7	Bit6	Bit5	Bit4	Bit3	Bit2	Bit1	Bit0
0Ch	R	-	-	-	-	AMB(3)	AMB(2)	AMB(1)	AMB(0)
Initial Value	(00h)	-	-	-	-	(0)	(0)	(0)	(0)

Bit[7:4] : (Not used)

Bit[3:0] : **AMB (3:0)** Ambient Level
 "0000" : 0h (Initial Value)
 "0001" : 1h
 "0010" : 2h
 "0011" : 3h
 "0100" : 4h
 "0101" : 5h
 "0110" : 6h
 "0111" : 7h
 "1000" : 8h
 "1001" : 9h
 "1010" : Ah
 "1011" : Bh
 "1100" : Ch
 "1101" : Dh
 "1110" : Eh
 "1111" : Fh

It begins to read Ambient data through I²C, and possible.
 To the first AD measurement completion, it is AMB(3:0)=0000.
 Refer to "(6) Ambient level detection" of "ALC" for detail.

Address 0Dh < Ambient LED Current setting >

Address	R/W	Bit7	Bit6	Bit5	Bit4	Bit3	Bit2	Bit1	Bit0
0Dh	W	-	IU0 (6)	IU0 (5)	IU0 (4)	IU0 (3)	IU0 (2)	IU0 (1)	IU0 (0)
Initial Value	13	-	0	0	1	0	0	1	1

Bit7 : (Not used)

Bit[6:0] : **IU0 (6:0)** Main Current at Ambient Level for 0h

"0000000" : 0.2 mA	"1000000" : 13.0 mA
"0000001" : 0.4 mA	"1000001" : 13.2 mA
"0000010" : 0.6 mA	"1000010" : 13.4 mA
"0000011" : 0.8 mA	"1000011" : 13.6 mA
"0000100" : 1.0 mA	"1000100" : 13.8 mA
"0000101" : 1.2 mA	"1000101" : 14.0 mA
"0000110" : 1.4 mA	"1000110" : 14.2 mA
"0000111" : 1.6 mA	"1000111" : 14.4 mA
"0001000" : 1.8 mA	"1001000" : 14.6 mA
"0001001" : 2.0 mA	"1001001" : 14.8 mA
"0001010" : 2.2 mA	"1001010" : 15.0 mA
"0001011" : 2.4 mA	"1001011" : 15.2 mA
"0001100" : 2.6 mA	"1001100" : 15.4 mA
"0001101" : 2.8 mA	"1001101" : 15.6 mA
"0001110" : 3.0 mA	"1001110" : 15.8 mA
"0001111" : 3.2 mA	"1001111" : 16.0 mA
"0010000" : 3.4 mA	"1010000" : 16.2 mA
"0010001" : 3.6 mA	"1010001" : 16.4 mA
"0010010" : 3.8 mA	"1010010" : 16.6 mA
"0010011" : 4.0 mA (Initial Value)	"1010011" : 16.8 mA
"0010100" : 4.2 mA	"1010100" : 17.0 mA
"0010101" : 4.4 mA	"1010101" : 17.2 mA
"0010110" : 4.6 mA	"1010110" : 17.4 mA
"0010111" : 4.8 mA	"1010111" : 17.6 mA
"0011000" : 5.0 mA	"1011000" : 17.8 mA
"0011001" : 5.2 mA	"1011001" : 18.0 mA
"0011010" : 5.4 mA	"1011010" : 18.2 mA
"0011011" : 5.6 mA	"1011011" : 18.4 mA
"0011100" : 5.8 mA	"1011100" : 18.6 mA
"0011101" : 6.0 mA	"1011101" : 18.8 mA
"0011110" : 6.2 mA	"1011110" : 19.0 mA
"0011111" : 6.4 mA	"1011111" : 19.2 mA
"0100000" : 6.6 mA	"1100000" : 19.4 mA
"0100001" : 6.8 mA	"1100001" : 19.6 mA
"0100010" : 7.0 mA	"1100010" : 19.8 mA
"0100011" : 7.2 mA	"1100011" : 20.0 mA
"0100100" : 7.4 mA	"1100100" : 20.2 mA
"0100101" : 7.6 mA	"1100101" : 20.4 mA
"0100110" : 7.8 mA	"1100110" : 20.6 mA
"0100111" : 8.0 mA	"1100111" : 20.8 mA
"0101000" : 8.2 mA	"1101000" : 21.0 mA
"0101001" : 8.4 mA	"1101001" : 21.2 mA
"0101010" : 8.6 mA	"1101010" : 21.4 mA
"0101011" : 8.8 mA	"1101011" : 21.6 mA
"0101100" : 9.0 mA	"1101100" : 21.8 mA
"0101101" : 9.2 mA	"1101101" : 22.0 mA
"0101110" : 9.4 mA	"1101110" : 22.2 mA
"0101111" : 9.6 mA	"1101111" : 22.4 mA
"0110000" : 9.8 mA	"1110000" : 22.6 mA
"0110001" : 10.0 mA	"1110001" : 22.8 mA
"0110010" : 10.2 mA	"1110010" : 23.0 mA
"0110011" : 10.4 mA	"1110011" : 23.2 mA
"0110100" : 10.6 mA	"1110100" : 23.4 mA
"0110101" : 10.8 mA	"1110101" : 23.6 mA
"0110110" : 11.0 mA	"1110110" : 23.8 mA
"0110111" : 11.2 mA	"1110111" : 24.0 mA
"0111000" : 11.4 mA	"1111000" : 24.2 mA
"0111001" : 11.6 mA	"1111001" : 24.4 mA
"0111010" : 11.8 mA	"1111010" : 24.6 mA
"0111011" : 12.0 mA	"1111011" : 24.8 mA
"0111100" : 12.2 mA	"1111100" : 25.0 mA
"0111101" : 12.4 mA	"1111101" : 25.2 mA
"0111110" : 12.6 mA	"1111110" : 25.4 mA
"0111111" : 12.8 mA	"1111111" : 25.6 mA

Address 0Eh < LED Max Current setting >

Address	R/W	Bit7	Bit6	Bit5	Bit4	Bit3	Bit2	Bit1	Bit0
0Eh	W	-	IU1 (6)	IU1 (5)	IU1 (4)	IU1 (3)	IU1 (2)	IU1 (1)	IU1 (0)
Initial Value	63h	-	1	1	0	0	0	1	1

Bit7 : (Not used)

Bit[6:0] : IU1 (6:0) LED Max Current (for ALC)

"0000000" : 0.2 mA	"1000000" : 13.0 mA
"0000001" : 0.4 mA	"1000001" : 13.2 mA
"0000010" : 0.6 mA	"1000010" : 13.4 mA
"0000011" : 0.8 mA	"1000011" : 13.6 mA
"0000100" : 1.0 mA	"1000100" : 13.8 mA
"0000101" : 1.2 mA	"1000101" : 14.0 mA
"0000110" : 1.4 mA	"1000110" : 14.2 mA
"0000111" : 1.6 mA	"1000111" : 14.4 mA
"0001000" : 1.8 mA	"1001000" : 14.6 mA
"0001001" : 2.0 mA	"1001001" : 14.8 mA
"0001010" : 2.2 mA	"1001010" : 15.0 mA
"0001011" : 2.4 mA	"1001011" : 15.2 mA
"0001100" : 2.6 mA	"1001100" : 15.4 mA
"0001101" : 2.8 mA	"1001101" : 15.6 mA
"0001110" : 3.0 mA	"1001110" : 15.8 mA
"0001111" : 3.2 mA	"1001111" : 16.0 mA
"0010000" : 3.4 mA	"1010000" : 16.2 mA
"0010001" : 3.6 mA	"1010001" : 16.4 mA
"0010010" : 3.8 mA	"1010010" : 16.6 mA
"0010011" : 4.0 mA	"1010011" : 16.8 mA
"0010100" : 4.2 mA	"1010100" : 17.0 mA
"0010101" : 4.4 mA	"1010101" : 17.2 mA
"0010110" : 4.6 mA	"1010110" : 17.4 mA
"0010111" : 4.8 mA	"1010111" : 17.6 mA
"0011000" : 5.0 mA	"1011000" : 17.8 mA
"0011001" : 5.2 mA	"1011001" : 18.0 mA
"0011010" : 5.4 mA	"1011010" : 18.2 mA
"0011011" : 5.6 mA	"1011011" : 18.4 mA
"0011100" : 5.8 mA	"1011100" : 18.6 mA
"0011101" : 6.0 mA	"1011101" : 18.8 mA
"0011110" : 6.2 mA	"1011110" : 19.0 mA
"0011111" : 6.4 mA	"1011111" : 19.2 mA
"0100000" : 6.6 mA	"1100000" : 19.4 mA
"0100001" : 6.8 mA	"1100001" : 19.6 mA
"0100010" : 7.0 mA	"1100010" : 19.8 mA
"0100011" : 7.2 mA	"1100011" : 20.0 mA (Initial Value)
"0100100" : 7.4 mA	"1100100" : 20.2 mA
"0100101" : 7.6 mA	"1100101" : 20.4 mA
"0100110" : 7.8 mA	"1100110" : 20.6 mA
"0100111" : 8.0 mA	"1100111" : 20.8 mA
"0101000" : 8.2 mA	"1101000" : 21.0 mA
"0101001" : 8.4 mA	"1101001" : 21.2 mA
"0101010" : 8.6 mA	"1101010" : 21.4 mA
"0101011" : 8.8 mA	"1101011" : 21.6 mA
"0101100" : 9.0 mA	"1101100" : 21.8 mA
"0101101" : 9.2 mA	"1101101" : 22.0 mA
"0101110" : 9.4 mA	"1101110" : 22.2 mA
"0101111" : 9.6 mA	"1101111" : 22.4 mA
"0110000" : 9.8 mA	"1110000" : 22.6 mA
"0110001" : 10.0 mA	"1110001" : 22.8 mA
"0110010" : 10.2 mA	"1110010" : 23.0 mA
"0110011" : 10.4 mA	"1110011" : 23.2 mA
"0110100" : 10.6 mA	"1110100" : 23.4 mA
"0110101" : 10.8 mA	"1110101" : 23.6 mA
"0110110" : 11.0 mA	"1110110" : 23.8 mA
"0110111" : 11.2 mA	"1110111" : 24.0 mA
"0111000" : 11.4 mA	"1111000" : 24.2 mA
"0111001" : 11.6 mA	"1111001" : 24.4 mA
"0111010" : 11.8 mA	"1111010" : 24.6 mA
"0111011" : 12.0 mA	"1111011" : 24.8 mA
"0111100" : 12.2 mA	"1111100" : 25.0 mA
"0111101" : 12.4 mA	"1111101" : 25.2 mA
"0111110" : 12.6 mA	"1111110" : 25.4 mA
"0111111" : 12.8 mA	"1111111" : 25.6 mA

Address 13h <LDO Power Control>

Address	R/W	Bit7	Bit6	Bit5	Bit4	Bit3	Bit2	Bit1	Bit0
13h	W/R	-	-	-	-	LDO4EN	LDO3EN	LDO2EN	LDO1EN
Initial Value	00h	-	-	-	-	0	0	0	0

Bit[7:4] : (Not used)

Bit3 : **LDO4EN** LDO4 control (ON/OFF)
 "0" : LDO4 OFF (Initial Value)
 "1" : LDO4 ON

Bit2 : **LDO3EN** LDO3 control (ON/OFF)
 "0" : LDO3 OFF (Initial Value)
 "1" : LDO3 ON

Bit1 : **LDO2EN** LDO2 control (ON/OFF)
 "0" : LDO2 OFF (Initial Value)
 "1" : LDO2 ON

Bit0 : **LDO1EN** LDO1 control (ON/OFF)
 "0" : LDO1 OFF (Initial Value)
 "1" : LDO1 ON

Address 14h <LDO1 Vout Control, LDO2 Vout Control >

Address	R/W	Bit7	Bit6	Bit5	Bit4	Bit3	Bit2	Bit1	Bit0
14h	R/W	LDO2VSEL3	LDO2VSEL2	LDO2VSEL1	LDO2VSEL0	LDO1VSEL3	LDO1VSEL2	LDO1VSEL1	LDO1VSEL0
Initial Value	74h	0	1	1	1	0	1	0	0

Bit[7:4] : LDO2VSEL [3:0]
 "0000" : 1.20 V
 "0001" : 1.30 V
 "0010" : 1.50 V
 "0011" : 1.60 V
 "0100" : 1.80 V
 "0101" : 2.20 V
 "0110" : 2.40 V
 "0111" : 2.50 V (Initial Value)
 "1000" : 2.60 V
 "1001" : 2.70 V
 "1010" : 2.80 V
 "1011" : 2.90 V
 "1100" : 3.00 V
 "1101" : 3.10 V
 "1110" : 3.20 V
 "1111" : 3.30 V

Bit[3:0] : LDO1VSEL [3:0]
 "0000" : 1.20 V
 "0001" : 1.30 V
 "0010" : 1.50 V
 "0011" : 1.60 V
 "0100" : 1.80 V (Initial Value)
 "0101" : 2.20 V
 "0110" : 2.40 V
 "0111" : 2.50 V
 "1000" : 2.60 V
 "1001" : 2.70 V
 "1010" : 2.80 V
 "1011" : 2.90 V
 "1100" : 3.00 V
 "1101" : 3.10 V
 "1110" : 3.20 V
 "1111" : 3.30 V

Address 15h < LDO3 Vout Control, LDO4 Vout Control >

Address	R/W	Bit7	Bit6	Bit5	Bit4	Bit3	Bit2	Bit1	Bit0
15h	R/W	LDO4VSEL3	LDO4VSEL2	LDO4VSEL1	LDO4VSEL0	LDO3VSEL3	LDO3VSEL2	LDO3VSEL1	LDO3VSEL0
Initial Value	A4h	1	0	1	0	0	1	0	0

Bit[7:4] : LDO4VSEL [3:0]

"0000" : 1.20 V
"0001" : 1.30 V
"0010" : 1.50 V
"0011" : 1.60 V
"0100" : 1.80 V
"0101" : 2.20 V
"0110" : 2.40 V
"0111" : 2.50 V
"1000" : 2.60 V
"1001" : 2.70 V
"1010" : 2.80 V (Initial Value)
"1011" : 2.90 V
"1100" : 3.00 V
"1101" : 3.10 V
"1110" : 3.20 V
"1111" : 3.30 V

Bit[3:0] : LDO3VSEL [3:0]

"0000" : 1.20 V
"0001" : 1.30 V
"0010" : 1.50 V
"0011" : 1.60 V
"0100" : 1.80 V (Initial Value)
"0101" : 2.20 V
"0110" : 2.40 V
"0111" : 2.50 V
"1000" : 2.60 V
"1001" : 2.70 V
"1010" : 2.80 V
"1011" : 2.90 V
"1100" : 3.00 V
"1101" : 3.10 V
"1110" : 3.20 V
"1111" : 3.30 V

●Reset

There are two kinds of reset, software reset and hardware reset

(1) Software reset

- All the registers are initialized by SFTRST="1".
- SFTRST is an automatically returned to "0". (Auto Return 0).

(2) Hardware reset

- It shifts to hardware reset by changing RESETB pin "H" → "L".
- The condition of all the registers under hardware reset pin is returned to the Initial Value, and it stops accepting all address.
- It's possible to release from a state of hardware reset by changing RESETB pin "L" → "H".
- RESETB pin has delay circuit. It doesn't recognize as hardware reset in "L" period under 5 μ s.

(3) Reset Sequence

- When hardware reset was done during software reset, software reset is canceled when hardware reset is canceled. (Because the Initial Value of software reset is "0")

●VIODET

The decline of the VIO voltage is detected, and faulty operation inside the IC is prevented by giving resetting to Levelsift block

Image Block Diagram

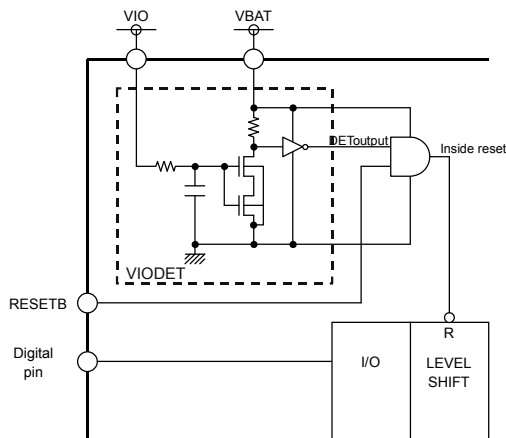

Fig.15

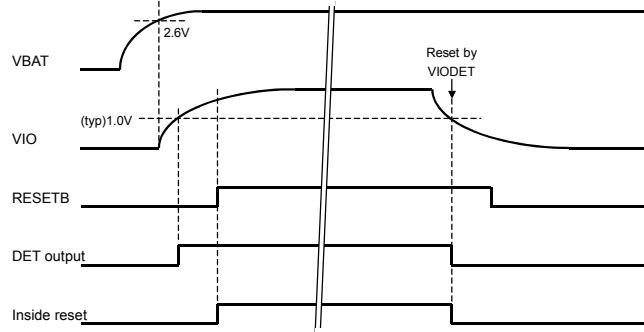

Fig.16

When the VIO voltage becomes more than typ1.0V(V_{th} of NMOS in the IC), VIODET is removed.

On the contrary, when VIO is as follows 1.0V, it takes reset.(The VBAT voltage being a prescribed movement range)

●Thermal Shut Down

A thermal shutdown function is effective in the following block.

- DC/DC (Charge Pump)
- LED Driver
- SBIAS
- LDO1, LDO2, LDO3, LDO4

The thermal shutdown function is detection temperature that it works is about 195°C.

Detection temperature has a hysteresis, and detection release temperature is about 175 °C.

(Design reference value)

●DC / DC

Start

DC/DC circuit operates when any LED turns ON. (DCDCFON=0)

When the start of the DC/DC circuit is done, it has the soft start function to prevent a rush current. Force of VBAT and VIO is to go as follows.

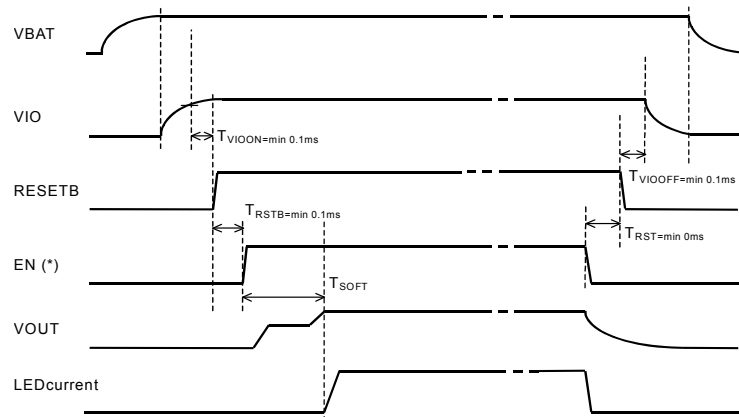

(*) An EN signal means the following in the upper figure.

EN = "MLEDEN" or "W * EN"

(= LED The LED lighting control of a setup of connection VOUT)

But, as for $T_a > T_{TSD}$ (typ : 195° C), a protection function functions, and an EN signal doesn't become effective.

T_{SOFT} changes by the capacitor connected to VOUT and inside OSC.

T_{SOFT} is Typ 200 μ s (when the output capacitor of VOUT =1.0 μ F).

Fig.17

Over Voltage protection / Over Current protection

DC/DC circuit output (VOUT) is equipped with the over-voltage protection and the over current protection function.

A VOUT over-voltage detection voltage is about 5.6V(typ). (VOUT at the time of rise in a voltage)

A detection voltage has a hysteresis, and a detection release voltage is about 5.4V (typ).

And, when VOUT output short to ground, input current of the battery terminal is limited by an over current protection function.

Mode transition

The transition of boosts multiple transits automatically by VBAT Voltage and the VOUT Pin Voltage.

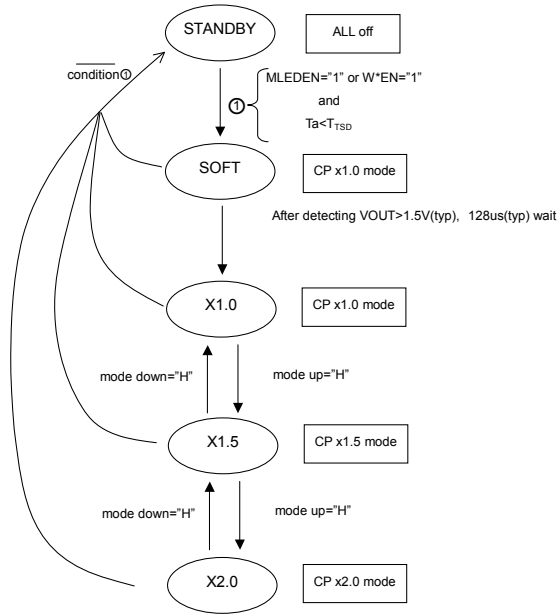

Fig.18

The mode transition of the charge pump works as follows.

<x1.0→x1.5→x2.0 Mode transition>

The transition of the mode is done when VOUT was compared with VBAT and the next condition was satisfied.

x1.0→x1.5 Mode transition
 $V_{BAT} \leq V_{OUT} + (R_{on10} \times I_{out})$
 (LED Pin feedback: $V_{OUT} = V_f + 0.2(\text{Typ})$)

x1.5→x2.0 Mode transition
 $V_{BAT} \times 1.5 \leq V_{OUT} + (R_{on15} \times I_{out})$
 (LED Pin feedback: $V_{OUT} = V_f + 0.2(\text{Typ})$)

R_{on10}: x1 Charge pump on resistance 1.4Ω(Typ)
 R_{on15}: x1.5 Charge pump on resistance 8.5Ω(Typ)

<x2.0→x1.5→x1.0 Mode transition>

The transition of the mode is done when the ratio of VOUT and VBAT is detected and it exceeds a fixed voltage ratio.

x1.5→x1.0 Mode transition
 $V_{BAT} / V_{OUT} = 1.16(\text{Design value})$

x2.0→x1.5 Mode transition
 $V_{BAT} / V_{OUT} = 1.12(\text{Design value})$

●LED Driver

The LED driver of 6ch is constructed as the ground plan.

Equivalence control is possible with LED1 - 4(LED4 can choose use/un-use with a register W4MD.).

LED5, LED6 is controllable individually.

As for LED5, LED6, grouping setting to the main control is possible, and main control becomes effective for the main group in the allotment. LED5 and LED6 are setups of grouping to the main control.

When LED5 and LED6 are used by the individual control, a slope time setup (register THL and TLH) doesn't become effective.

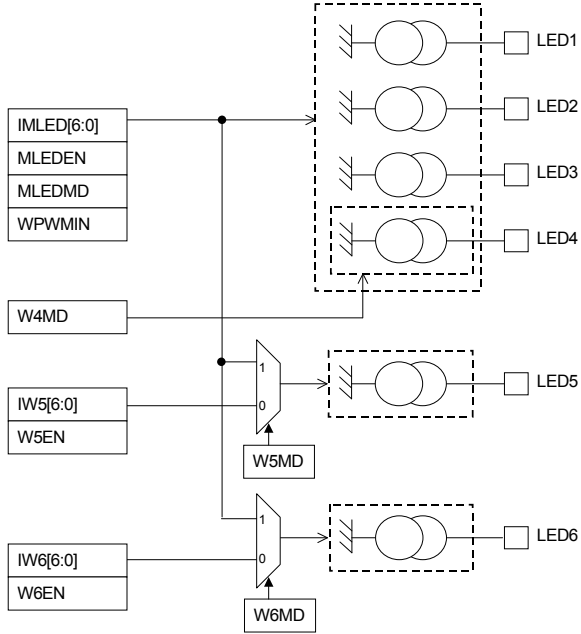

Fig.19

LED Composition which can be set up is the following.

The main, other1 and other2 are controllable to each.(Enable and current setting)

Main (ALC,PWM)	Other1	Other2
6LEDs	-	-
5LEDs	-	-
5LEDs	1LED	-
4LEDs	-	-
4LEDs	1 LED	-
4LEDs	2 LEDs	-
4LEDs	1 LED	1LED
3LEDs	-	-
3LEDs	1 LED	-
3LEDs	2 LEDs	-
3LEDs	1 LED	1LED

●ALC (Auto Luminous Control)

LCD backlight current adjustment is possible in the basis of the data detected by external ambient light sensor.

- Extensive selection of the ambient light sensors (Photo Diode, Photo Transistor, Photo IC(linear / logarithm)) is possible by building adjustment feature of Sensor bias, gain adjustment and offset adjustment.
- Ambient data is changed into ambient level by digital data processing, and it can be read through I²C I / F.
- Register setting can customize a conversion to LED current. (Initial Value is pre-set.)
- Natural dimming of LED driver is possible with the adjustment of the current transition speed.

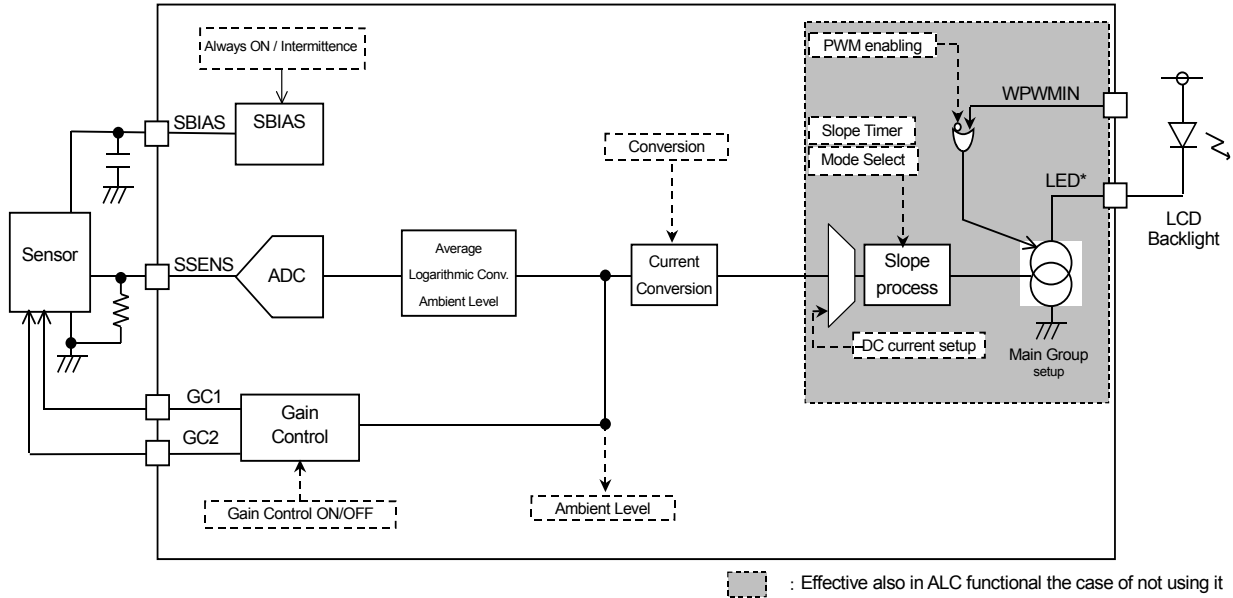

Fig.20

(1)Auto Luminous Control ON/OFF

- ALC block can be independent setting ON/OFF.
- It can use only to measure the Ambient level.
Register: ALCEN
Register: MLEDEN
Register: MLEDMD
- Refer to under about the associate ALC mode and Main LED current.

ALCEN	MLEDEN	MLEDMD	Sensor I/F	LED control	Mode	Main LED current
0	0	x	OFF (AMB(3:0)=0h)	OFF	OFF	-
0	1	0		ON	Non ALC mode	IMLED(6:0)
0	1	1				IU0(6:0) (*1)
1	0	x	ON	OFF	ALC mode	-
1	1	0		ON		IMLED(6:0)
1	1	1				ALC mode (*2)

(*1) At this mode, because Sensor I/F is OFF, AMB(3:0)=0h.
So, Main LED current is selected IU0(6:0).
(*2) At this mode, Main LED current is calculated (See(8)Convert LED Current)
It becomes current value corresponding to each brightness.

(2) I/V conversion

- External resistance for the I-V conversion (R_s) are adjusted with adaptation of sensor characteristic

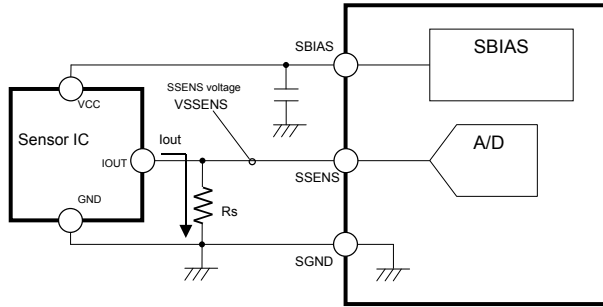

R_s : Sense resistance (A sensor output current is changed into the voltage value.)
 SBIAS : Bias power supply terminal for the sensor
 SSENS : Sense voltage input terminal

$$\text{SSENS Voltage} = I_{out} \times R_s$$

Fig.21

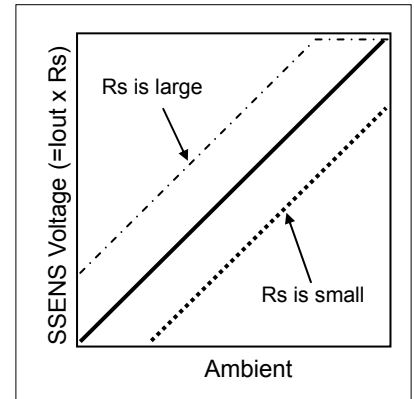
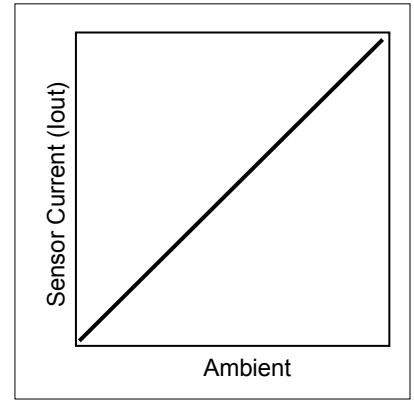

(3) Gain control

- Sensor gain switching function is built in to extend the dynamic range.
- It is controlled by register setup.
- When automatic gain control is off, the gain status can be set up in the manual.
Register : GAIN
- GC1 and GC2 are outputted corresponding to each gain status.

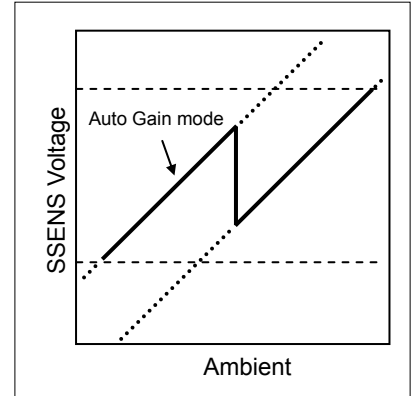
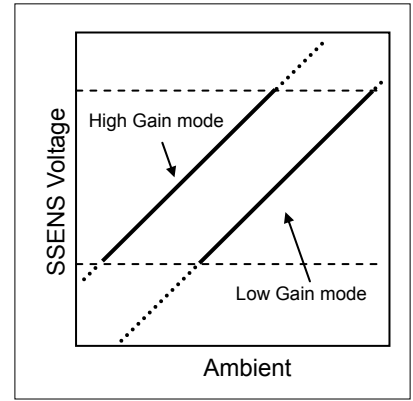

	Example 1 (Use BH1621FVC)		Example 2		Example 3	
Application example			 Resistor values are relative			
Operating mode	Auto		Auto		Fixed	
GAIN setting	0		0		1	
Gain status	High	Low	High	Low	-	
GC1 output		L		L		
GC2 output	L		L		L	

⏏ : This means that it becomes High with A/D measurement cycle synchronously.

(*1): Set up the relative ratio of the resistance in the difference in the brightness change of the High Gain mode and the Low Gain mode carefully.

(4) A/D conversion

- The detection of ambient data is done periodically for the low power.
- SBIAS and ADC are turned off except for the ambient measurement.
- The sensor current may be shut in this function, it can possible to decrease the current consumption.
- SBIAS pin and SSENS pin are pull-down in internal when there are OFF.
- SBIAS circuit has the two modes. (Usually ON mode or intermittent mode)

Register: ADCYC
Register: SBIASON

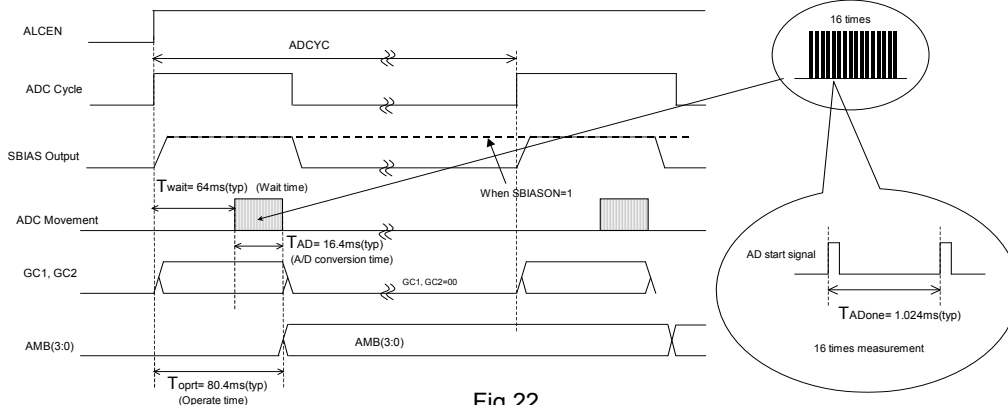

Fig.22

(5) Average filter

- Average filter is built in to rid noise or flicker. Average is 16 times

(6) Ambient level detection

- Averaged A/D value is converted to Ambient level corresponding to Gain control.
- Ambient level is judged to rank of 16 steps by ambient data.
- Ambient level is output through I²C.

Register: AMB(3:0)

GAIN	0		1
	Low	High	-
Ambient Level	SSENS Voltage		
0h	/	VoS × 0 / 256	VoS × 0 / 256
1h		VoS × 1 / 256	VoS × 1 / 256
2h		VoS × 2 / 256	VoS × 2 / 256
3h		VoS × 3 / 256	VoS × 3 / 256
		VoS × 4 / 256	VoS × 4 / 256
4h	VoS × 5 / 256	VoS × 5 / 256	
	VoS × 7 / 256	VoS × 6 / 256	
5h	VoS × 0 / 256	VoS × 8 / 256 VoS × 12 / 256	VoS × 7 / 256 VoS × 9 / 256
6h	VoS × 1 / 256	VoS × 13 / 256 VoS × 21 / 256	VoS × 10 / 256 VoS × 13 / 256
7h	VoS × 2 / 256	VoS × 22 / 256	VoS × 14 / 256
	VoS × 3 / 256	VoS × 37 / 256	VoS × 19 / 256
8h	VoS × 4 / 256	VoS × 38 / 256	VoS × 20 / 256
	VoS × 6 / 256	VoS × 65 / 256	VoS × 27 / 256
9h	VoS × 7 / 256	VoS × 66 / 256	VoS × 28 / 256
	VoS × 11 / 256	VoS × 113 / 256	VoS × 38 / 256
Ah	VoS × 12 / 256	VoS × 114 / 256	VoS × 39 / 256
	VoS × 20 / 256	VoS × 199 / 256	VoS × 53 / 256
Bh	VoS × 21 / 256	VoS × 200 / 256	VoS × 54 / 256
	VoS × 36 / 256	VoS × 255 / 256	VoS × 74 / 256
Ch	VoS × 37 / 256	/	VoS × 75 / 256
	VoS × 64 / 256		VoS × 104 / 256
Dh	VoS × 65 / 256		VoS × 105 / 256
	VoS × 114 / 256		VoS × 144 / 256
Eh	VoS × 115 / 256		VoS × 145 / 256
	VoS × 199 / 256	VoS × 199 / 256	
Fh	VoS × 200 / 256	VoS × 200 / 256	
	VoS × 255 / 256	VoS × 255 / 256	

※In the Auto Gain control mode, sensor gain changes in gray-colored ambient level.

※“/”: This means that this zone is not outputted in this mode.

(7)Convert LED Current

- LED current can be assigned as each of 16 steps of the ambient level.
- Convert LED Current by Min Current setting,Max Current setting,step setting and curbu setting.

Register: IU0
 IU1
 CRV
 STEP [2:0]

Conversion Table (Initial Value)

Ambient Level	Coefficient		Ambient Level	Coefficient	
	CRV=0	CRV=1		CRV=0	CRV=1
0h	0	0	8h	6.5	8
1h	0.25	1	9h	8	9
2h	0.5	2	Ah	10	10
3h	1	3	Bh	12	11
4h	1.5	4	Ch	13	12
5h	2.5	5	Dh	14	13
6h	3.5	6	Eh	15	14
7h	5	7	Fh	16	15

Step Table Setting

STEP[2:0]	ΔI
000	1.0mA
001	1.1mA
010	1.2mA
011	1.3mA
100	1.6mA
101	1.7mA
110	1.8mA
111	1.9mA

$I = \Delta I \times \text{Coefficient} + IU0$

- ※ $I \geq IU1: I = IU1$
- ※ $\Delta I \times \text{Coefficient}$
Drop under 1mA

The example of a setting

IU0=4mA
 IU1=20mA

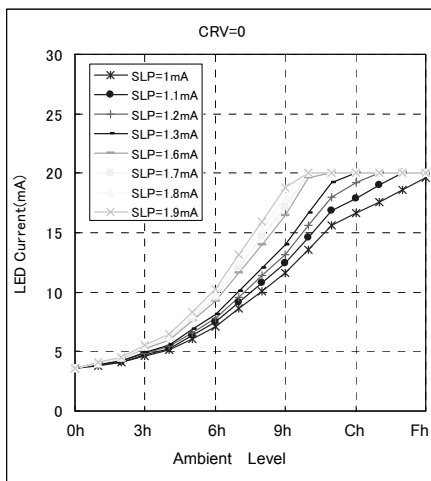

Fig.23

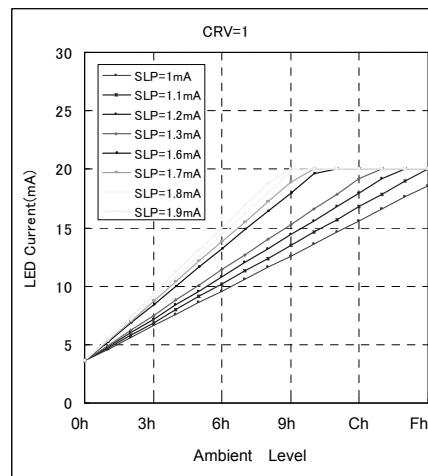

Fig.24

(8) Slope process

- Slope process is given to LED current to dim naturally.
- LED current changes in the 256Step gradation in sloping.
- Up(dark→bright),Down(bright→dark) LED current transition speed are set individually.
 Register: THL (3:0)
 Register: TLH (3:0)
- Main LED current changes as follows at the time as the slope.
 TLH (THL) is setup of time of the current step 2/256.

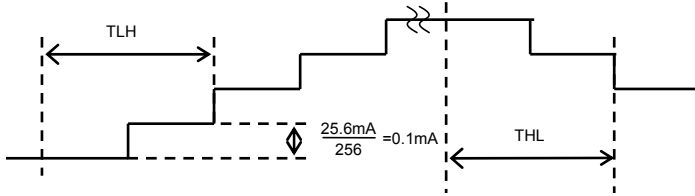
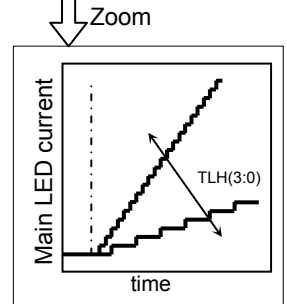
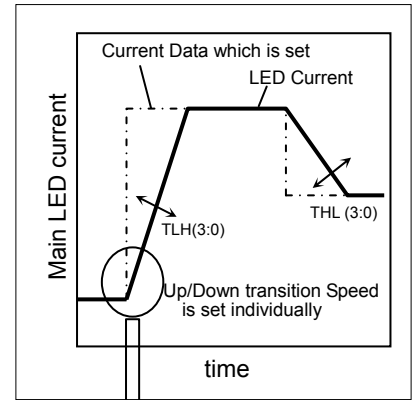
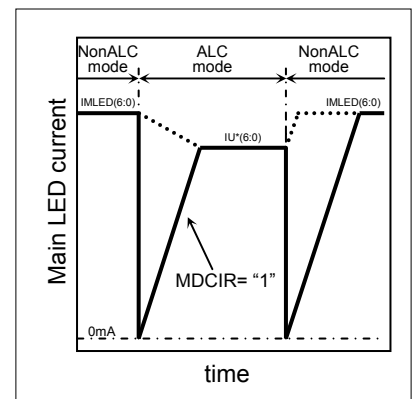
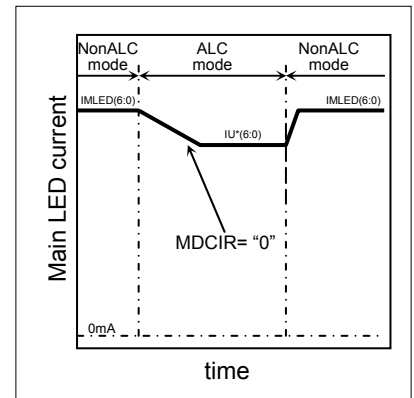

Fig.25



(9) LED current reset when mode change

- When mode is changed (ALC↔Non ALC), it can select the way to sloping.
 Register : MDCIR
 "0" : LED current non-reset when mode change
 "1" : LED current reset when mode change



(10) Current adjustment

- When the register setting permits it, PWM drive by the external terminal (WPWMIN) is possible.
Register : WPWMEN
- It is suitable for the intensity correction by external control, because PWM based on Main LED current of register setup or ALC control.

WPWMEN (Register)	WPWMIN(External Pin)	Main group LED current
0	L	Normal operation
	H	Normal operation
1	L	Forced OFF
	H	Normal operation

"Normal operation" depends on the setup of each register.

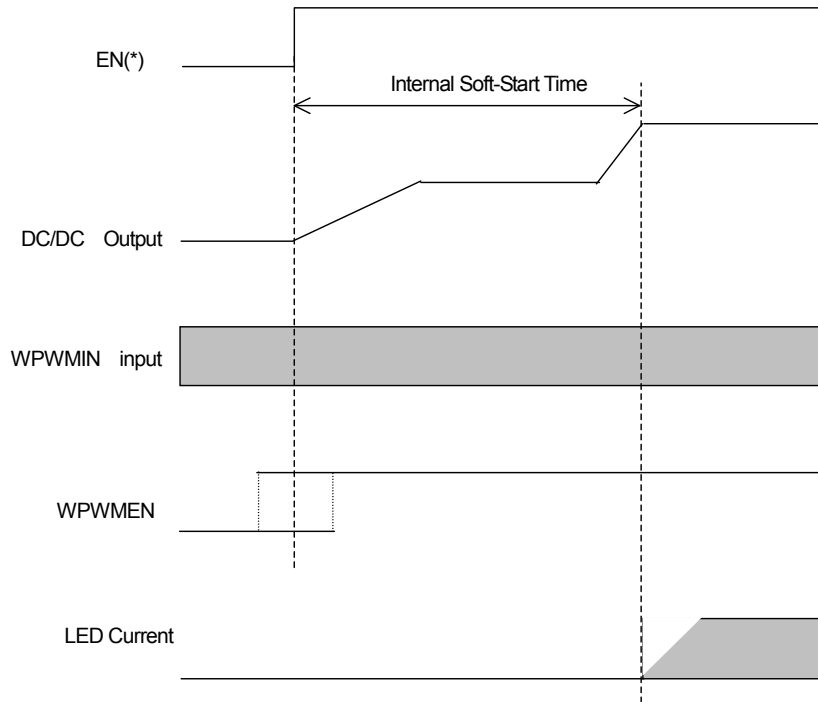

EN(*) : it means "MLEDEN" or "W*EN".

It is possible to make it a WPWMIN input and WPWMEN=1 in front of EN(*).
A PWM drive becomes effective after the time of an LED current standup.

When rising during PWM operation, as for the standup time of a DC/DC output, only the rate of PWM Duty becomes late. Appearance may be influenced when extremely late frequency and extremely low Duty are inputted.

Please secure 250 μs or more of H sections at the time of PWM pulse Force.

Fig.26

● I/O

When the RESETB pin is Low, the input buffers (SDA and SCL) are disabling for the Low consumption power.

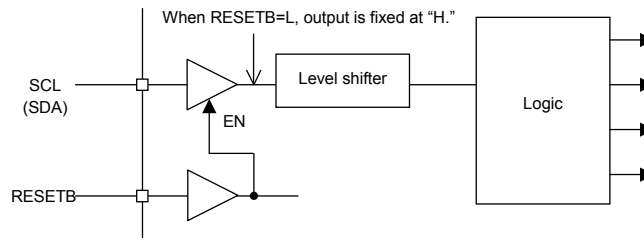

Fig.27

Special care should be taken because a current path may be formed via a terminal protection diode, depending on an I/O power-on sequence or an input level.

● About the start of LDO1~LDO4

It must start as follows.

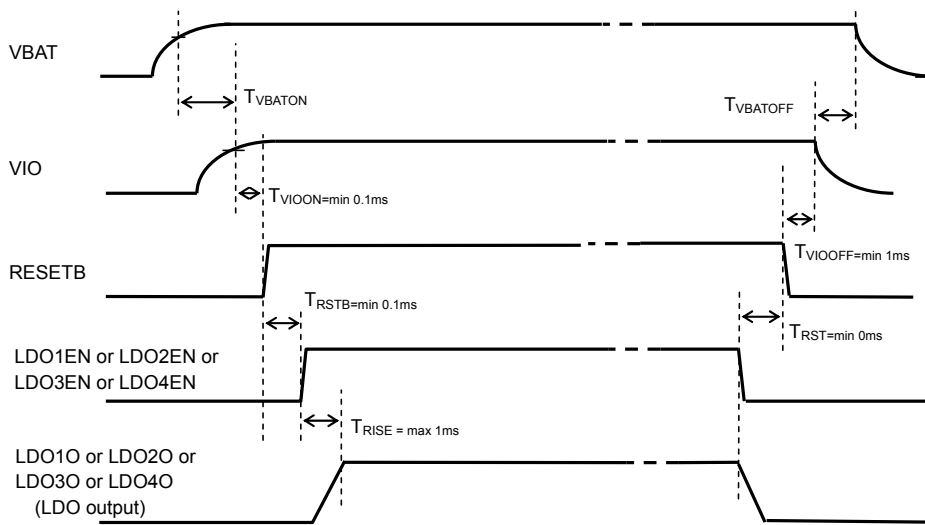

Fig.28

<Start Sequence>

VBAT ON (Enough rise up) → VIO ON (Enough rise up) → Reset release → LDO ON (Register access acceptable)

<End Sequence>

LDO OFF → Reset → VIO OFF (Enough fall down) → VBAT OFF

● About the pin management of the function that isn't used and test pins

Setting it as follows is recommended with the test pin and the pin which isn't used.

Set up pin referring to the "Equivalent circuit diagram" so that there may not be a problem under the actual use.

T2, T4	Short to GND because pin for test input
T1, T3	OPEN because pin for test output
Non-used LED Pin	Short to GND (Must) But, the setup of a register concerned with LED that isn't used is prohibited.
WPWMIN	Short to ground (A Pull-Down resistance built-in terminal is contained, too.)

● Operation Settings (Flow Example)

1. Backlight: Auto Luminous Mode

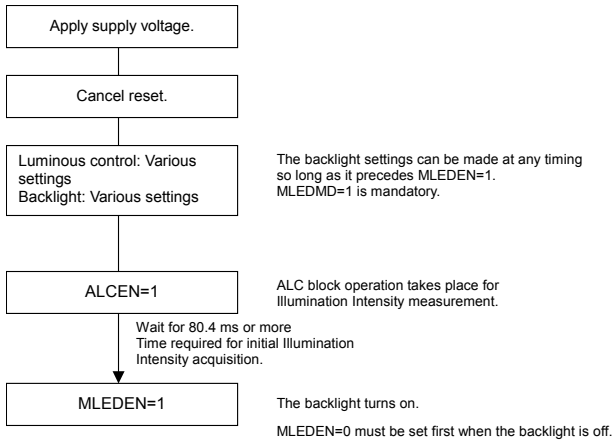

Fig.29

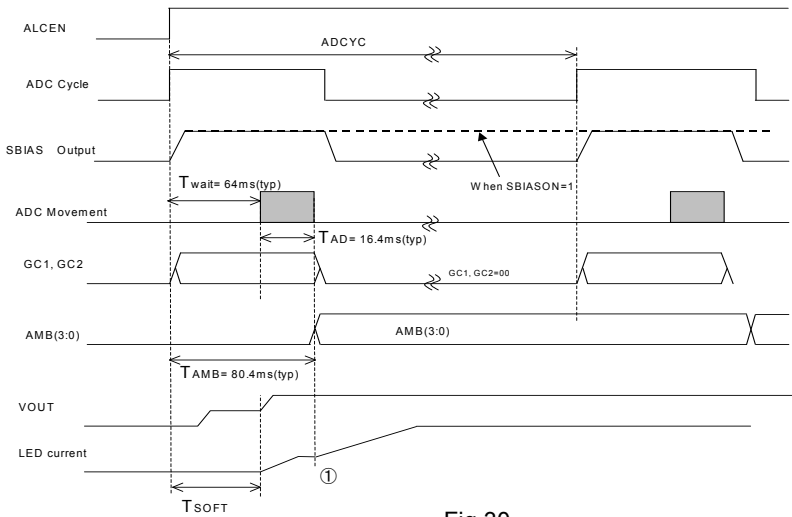

Fig.30

When It cannot wait for the first illumination measurement, backlight lighting is possible with ALCEN. But the extremely short case of slope rise time, a shoulder may be done like ① for an LED electric current. (To the first illumination measurement for AMB(3:0)=00h)

2. Backlight: Fade-in/Fade-out

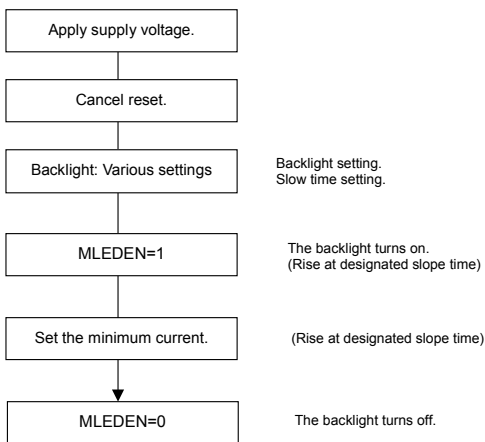

Fig.31

3. Backlight without Auto Luminous Mode

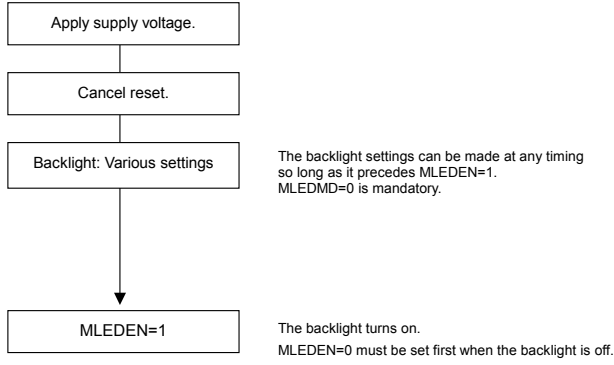

Fig.32

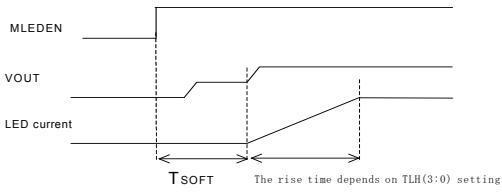

Fig.33

●PCB Pattern of the Power Dissipation Measuring Board

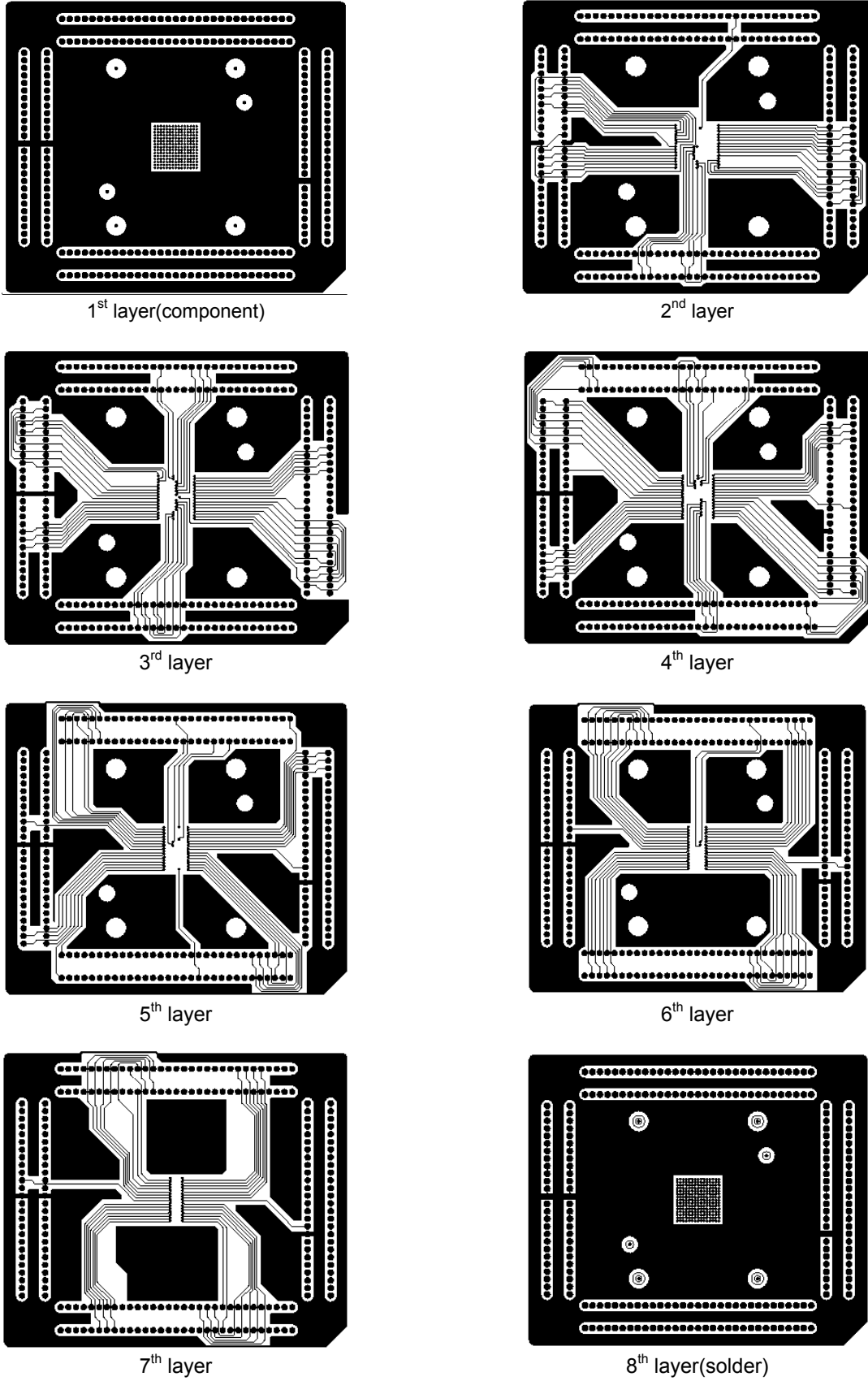

Fig.34 PCB Pattern of the Power Dissipation Measuring Board

●Notes for Use

- (1) Absolute Maximum Ratings
An excess in the absolute maximum ratings, such as supply voltage, temperature range of operating conditions, etc., can break down devices, thus making impossible to identify breaking mode such as a short circuit or an open circuit. If any special mode exceeding the absolute maximum ratings is assumed, consideration should be given to take physical safety measures including the use of fuses, etc.
- (2) Power supply and ground line
Design PCB pattern to provide low impedance for the wiring between the power supply and the ground lines. Pay attention to the interference by common impedance of layout pattern when there are plural power supplies and ground lines. Especially, when there are ground pattern for small signal and ground pattern for large current included the external circuits, please separate each ground pattern. Furthermore, for all power supply pins to ICs, mount a capacitor between the power supply and the ground pin. At the same time, in order to use a capacitor, thoroughly check to be sure the characteristics of the capacitor to be used present no problem including the occurrence of capacity dropout at a low temperature, thus determining the constant.
- (3) Ground voltage
Make setting of the potential of the ground pin so that it will be maintained at the minimum in any operating state. Furthermore, check to be sure no pins are at a potential lower than the ground voltage including an actual electric transient.
- (4) Short circuit between pins and erroneous mounting
In order to mount ICs on a set PCB, pay thorough attention to the direction and offset of the ICs. Erroneous mounting can break down the ICs. Furthermore, if a short circuit occurs due to foreign matters entering between pins or between the pin and the power supply or the ground pin, the ICs can break down.
- (5) Operation in strong electromagnetic field
Be noted that using ICs in the strong electromagnetic field can malfunction them.
- (6) Input pins
In terms of the construction of IC, parasitic elements are inevitably formed in relation to potential. The operation of the parasitic element can cause interference with circuit operation, thus resulting in a malfunction and then breakdown of the input pin. Therefore, pay thorough attention not to handle the input pins, such as to apply to the input pins a voltage lower than the ground respectively, so that any parasitic element will operate. Furthermore, do not apply a voltage to the input pins when no power supply voltage is applied to the IC. In addition, even if the power supply voltage is applied, apply to the input pins a voltage lower than the power supply voltage or within the guaranteed value of electrical characteristics.
- (7) External capacitor
In order to use a ceramic capacitor as the external capacitor, determine the constant with consideration given to a degradation in the nominal capacitance due to DC bias and changes in the capacitance due to temperature, etc.
- (8) Thermal shutdown circuit (TSD)
This IC builds in a thermal shutdown (TSD) circuit. When junction temperatures become detection temperature or higher, the thermal shutdown circuit operates and turns a switch OFF. The thermal shutdown circuit, which is aimed at isolating the IC from thermal runaway as much as possible, is not aimed at the protection or guarantee of the IC. Therefore, do not continuously use the IC with this circuit operating or use the IC assuming its operation.
- (9) Thermal design
Perform thermal design in which there are adequate margins by taking into account the permissible dissipation (Pd) in actual states of use.
- (10) LDO
Use each output of LDO by the independence. Don't use under the condition that each output is short-circuited because it has the possibility that an operation becomes unstable.
- (11) About the pin for the test, the un-use pin
Prevent a problem from being in the pin for the test and the un-use pin under the state of actual use. Please refer to a function manual and an application notebook. And, as for the pin that doesn't specially have an explanation, ask our company person in charge.
- (12) About the rush current
For ICs with more than one power supply, it is possible that rush current may flow instantaneously due to the internal powering sequence and delays. Therefore, give special consideration to power coupling capacitance, power wiring, width of ground wiring, and routing of wiring.
- (13) About the function description or application note or more.
The function description and the application notebook are the design materials to design a set. So, the contents of the materials aren't always guaranteed. Please design application by having fully examination and evaluation include the external elements.

●Ordering Part Number

B	D
---	---

Part No.

6	0	8	3
---	---	---	---

Part No.

G	U	L
---	---	---

Package
GUL: VCSP50L3

E	2
---	---

Packaging and forming specification
E2: Embossed tape and reel

VCSP50L3(BD6083GUL)

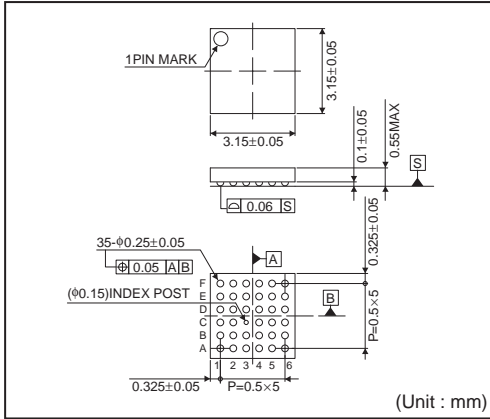

<Tape and Reel information>

Tape	Embossed carrier tape (heat sealing method)
Quantity	2500pcs
Direction of feed	E2 (The direction is the 1pin of product is at the upper left when you hold reel on the left hand and you pull out the tape on the right hand)

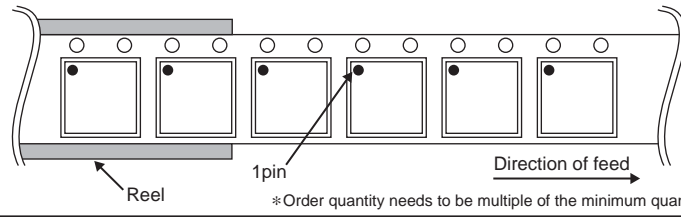

Notes

No copying or reproduction of this document, in part or in whole, is permitted without the consent of ROHM Co.,Ltd.

The content specified herein is subject to change for improvement without notice.

The content specified herein is for the purpose of introducing ROHM's products (hereinafter "Products"). If you wish to use any such Product, please be sure to refer to the specifications, which can be obtained from ROHM upon request.

Examples of application circuits, circuit constants and any other information contained herein illustrate the standard usage and operations of the Products. The peripheral conditions must be taken into account when designing circuits for mass production.

Great care was taken in ensuring the accuracy of the information specified in this document. However, should you incur any damage arising from any inaccuracy or misprint of such information, ROHM shall bear no responsibility for such damage.

The technical information specified herein is intended only to show the typical functions of and examples of application circuits for the Products. ROHM does not grant you, explicitly or implicitly, any license to use or exercise intellectual property or other rights held by ROHM and other parties. ROHM shall bear no responsibility whatsoever for any dispute arising from the use of such technical information.

The Products specified in this document are intended to be used with general-use electronic equipment or devices (such as audio visual equipment, office-automation equipment, communication devices, electronic appliances and amusement devices).

The Products specified in this document are not designed to be radiation tolerant.

While ROHM always makes efforts to enhance the quality and reliability of its Products, a Product may fail or malfunction for a variety of reasons.

Please be sure to implement in your equipment using the Products safety measures to guard against the possibility of physical injury, fire or any other damage caused in the event of the failure of any Product, such as derating, redundancy, fire control and fail-safe designs. ROHM shall bear no responsibility whatsoever for your use of any Product outside of the prescribed scope or not in accordance with the instruction manual.

The Products are not designed or manufactured to be used with any equipment, device or system which requires an extremely high level of reliability the failure or malfunction of which may result in a direct threat to human life or create a risk of human injury (such as a medical instrument, transportation equipment, aerospace machinery, nuclear-reactor controller, fuel-controller or other safety device). ROHM shall bear no responsibility in any way for use of any of the Products for the above special purposes. If a Product is intended to be used for any such special purpose, please contact a ROHM sales representative before purchasing.

If you intend to export or ship overseas any Product or technology specified herein that may be controlled under the Foreign Exchange and the Foreign Trade Law, you will be required to obtain a license or permit under the Law.



Thank you for your accessing to ROHM product informations.
More detail product informations and catalogs are available, please contact us.



ROHM Customer Support System

<http://www.rohm.com/contact/>



Looking for pricing, stock, or lifecycle information?

Click below to explore more details on WIN SOURCE:

-  [View BD6083GUL on WIN SOURCE](#)
-  [Rohm Semiconductor](#) Information

Optimize Your Supply Chain with WIN SOURCE Solutions

-  Global Sourcing Solution
-  Obsolete Management
-  Cost Control Management
-  Shortage Management
-  Alternative Solution
-  Excess Inventory Management