



**THE DATASHEET OF
FOD8342T**



3.0 A Output Current, High Speed Gate Drive Optocoupler in Stretched Body SOP 6-Pin

FOD8342, FOD8342T

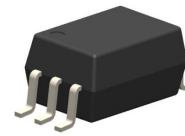

SOIC6
CASE 751EL

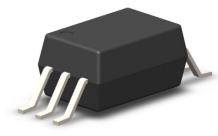

SOIC6 W
CASE 751EM

Description

The FOD8342 series is a 3.0 A output current gate drive optocoupler, capable of driving medium-power IGBT/ MOSFETs. It is ideally suited for fast-switching driving of power IGBT and MOSFET used in motor-control inverter applications, and high-performance power systems.

The FOD8342 series utilizes stretched body package to achieve 8 mm creepage and clearance distances (FOD8342T), and optimized IC design to achieve reliably high-insulation voltage and high-noise immunity.

The FOD8342 series consists of an Aluminum Gallium Arsenide (AlGaAs) Light-Emitting Diode (LED) optically coupled to an integrated circuit with a high-speed driver for push-pull MOSFET output stage. The device is housed in a stretched body, 6-pin, small outline, plastic package.

Features

- FOD8342T – 8 mm Creepage and Clearance Distance, and 0.4 mm Insulation Distance to Achieve Reliable and High-Voltage Insulation
- 3.0 A Peak Output Current Driving Capability for Medium-Power IGBT/MOSFET
 - ◆ Use of P-Channel MOSFETs at Output Stage Enables Output Voltage Swing Close to Supply Rail
- 20 kV/μs Minimum Common Mode Rejection
- Wide Supply Voltage Range: 10 V to 30 V
- Fast Switching Speed Over Full Operating Temperature Range
 - ◆ 210 ns Maximum Propagation Delay
 - ◆ 65 ns Maximum Pulse Width Distortion
- Under-Voltage Lockout (UVLO) with Hysteresis
- Extended Industrial Temperature Range: -40°C to 100°C
- Safety and Regulatory Approvals:
 - ◆ UL1577, 5,000 V_{RMS} for 1 Minute
 - ◆ DIN EN/IEC60747-5-5, 1,140V Peak Working Insulation Voltage

Applications

- AC and Brushless DC Motor Drives
- Industrial Inverter
- Uninterruptible Power Supply
- Induction Heating
- Isolated IGBT/Power MOSFET Gate Drive

MARKING DIAGRAM

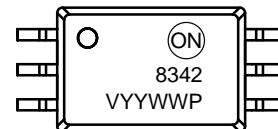

- 8342 = Specific Device Number
- V = DIN EN/IEC60747-5-5 Option
- YY = Two Digit Year Code
- WW = Two Digit Work Week
- P = Assembly Package Code

FUNCTIONAL SCHEMATIC

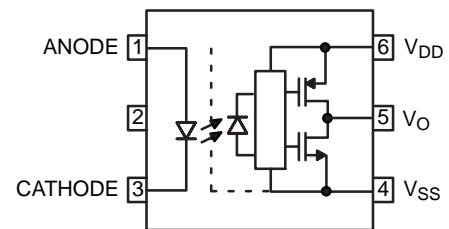

ORDERING INFORMATION

See detailed ordering, marking and shipping information in the package dimensions section on page 18 of this data sheet.

Related Resources

- [FOD3182, 3 A Output Current, High Speed MOSFET Gate Drive Optocoupler](#)
- [FOD8314, FOD8314T, 1.0 A Output Current, Gate Drive Optocoupler in Stretched Body SOP 6-Pin](#)
- www.onsemi.com

FOD8342, FOD8342T

Table 1. TRUTH TABLE

LED	$V_{DD} - V_{SS}$ "Positive Going" (Turn-On)	$V_{DD} - V_{SS}$ "Negative Going" (Turn-Off)	V_O
Off	0 V to 30 V	0 V to 30 V	LOW
On	0 V to 7 V	0 V to 6.5 V	LOW
On	7 V to 9.5 V	6.5 V to 9 V	Transition
On	9.5 V to 30 V	9 V to 30 V	HIGH

Table 2. PIN DESCRIPTION

Pin No.	Name	Description
1	ANODE	LED Anode
2	N.C	Not Connection
3	CATHODE	LED Cathode
4	V_{SS}	Negative Supply Voltage
5	V_O	Output Voltage
6	V_{DD}	Positive Supply Voltage

Pin Configuration

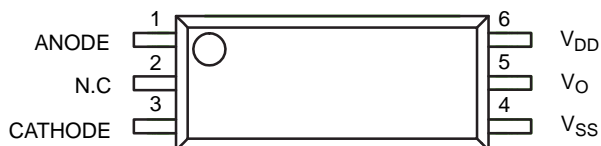

Figure 1. Pin Configuration

FOD8342, FOD8342T

Table 3. SAFETY AND INSULATION RATINGS

As per DIN_EN/IEC60747-5-5. This optocoupler is suitable for "safe electrical insulation" only within the safety limit data. Compliance with the safety ratings shall be ensured by means of protective circuits.

Parameter		Symbol	FOD8342	FOD8342T	Unit
Installation Classifications per DIN VDE 0110/1.89 Table 1, For Rated Main Voltage	<150 Vrms		I-IV	I-IV	
	<300 Vrms		I-IV	I-IV	
	<450 Vrms		I-III	I-IV	
	<600 Vrms		I-III	I-III	
Climatic Classification			40/100/21	40/100/21	
Pollution Degree (DIN VDE 0110/1.89)			2	2	
Comparative Tracking Index		CTI	175	175	
Input to Output Test Voltage, Method B, $V_{IORM} \times 1.875 = V_{PR}$, 100% Production Test with $t_m = 1$ sec, Partial Discharge <5 pC		V_{PR}	1,671	2,137	V_{peak}
Input to Output Test Voltage, Method A, $V_{IORM} \times 1.6 = V_{PR}$, Type and Sample Test with $t_m = 10$ sec, Partial Discharge <5 pC			1,426	1,824	V_{peak}
Max Working Insulation Voltage		V_{IORM}	891	1,140	V_{peak}
Highest Allowable Over Voltage		V_{IOTM}	6,000	8,000	V_{peak}
External Creepage			≥8.0	≥8.0	mm
External Clearance			≥7.0	≥8.0	mm
Distance Through Insulation (Insulation Thickness)		DTI	≥0.4	≥0.4	mm
Safety Limit Values- Maximum Values Allowed in the Event of a Failure,					
Case Temperature		T_S	150	150	°C
Input Current		$I_{S,INPUT}$	200	200	mA
Output Power		$P_{S,OUTPUT}$	600	600	mW
Insulation Resistance at $T_S, V_{IO} = 500$ V		R_{IO}	10^9	10^9	Ω

FOD8342, FOD8342T

Table 4. ABSOLUTE MAXIMUM RATINGS ($T_A = 25^\circ\text{C}$ unless otherwise specified)

Symbol	Parameter	Value	Units
T_{STG}	Storage Temperature	-40 to +125	$^\circ\text{C}$
T_{OPR}	Operating Temperature	-40 to +100	$^\circ\text{C}$
T_J	Junction Temperature	-40 to +125	$^\circ\text{C}$
T_{SOL}	Lead Solder Temperature (<i>Refer to Reflow Temperature Profile</i>)	260 for 10 s	$^\circ\text{C}$
$I_{F(AVG)}$	Average Input Current	25	mA
V_R	Reverse Input Voltage	5.0	V
$I_{O(PEAK)}$	Peak Input Voltage (Note 1)	3	A
V_{DD}	Supply Voltage	-0.5 to 35	V
$V_{O(PEAK)}$	Peak Output Voltage	0 to V_{DD}	V
$t_{R(IN)}, t_{F(IN)}$	Input Signal Rise and Fall Time	250	ns
PD_I	Input Power Dissipation (Notes 2, 4)	45	mW
PD_O	Output Power Dissipation (Notes 3, 4)	500	mW

Stresses exceeding those listed in the Maximum Ratings table may damage the device. If any of these limits are exceeded, device functionality should not be assumed, damage may occur and reliability may be affected.

1. Maximum pulse width = 10 μs , maximum duty cycle = 0.2%.
2. No derating required across operating temperature range.
3. Derate linearly from 25 $^\circ\text{C}$ at a rate of 5.2 mW/ $^\circ\text{C}$.
4. Functional operation under these conditions is not implied. Permanent damage may occur if the device is subjected to conditions outside these ratings.

Table 5. RECOMMENDED OPERATING CONDITIONS

Symbol	Parameter	Min	Max	Unit
T_A	Ambient Operating Temperature	-40	+100	$^\circ\text{C}$
$V_{DD} - V_{SS}$	Supply Voltages	10	30	V
$I_{F(ON)}$	Input Current (ON)	10	16	mA
$V_{F(OFF)}$	Input Voltage (OFF)	-3.0	0.8	V

Functional operation above the stresses listed in the Recommended Operating Ranges is not implied. Extended exposure to stresses beyond the Recommended Operating Ranges limits may affect device reliability.

Table 6. ISOLATION CHARACTERISTICS (Apply over all recommended conditions, typical value is measured at $T_A = 25^\circ\text{C}$)

Symbol	Parameter	Conditions	Min	Typ	Max	Units
V_{ISO}	Input-Output Isolation Voltage	$T_A = 25^\circ\text{C}$, R.H. < 50%, $t = 1.0$ min, $I_{I-O} \leq 20 \mu\text{A}$ (Notes 5, 6)	5000			V_{ACRMS}
R_{ISO}	Isolation Resistance	$V_{I-O} = 500$ V (Note 5)		10^{11}		Ω
C_{ISO}	Isolation Capacitance	$V_{I-O} = 0$ V, freq = 1.0 MHz (Note 5)		1		pF

5. Device is considered a two terminal device: Pins 1, 2 and 3 are shorted together and Pins 4, 5, and 6 are shorted together.
6. 5,000 V_{ACRMS} for 1 minute duration is equivalent to 6,000 V_{ACRMS} for 1 second duration.

FOD8342, FOD8342T

Table 7. ELECTRICAL CHARACTERISTICS (Apply over all recommended conditions, $T_A = -40^{\circ}\text{C}$ to $+100^{\circ}\text{C}$, $4.5\text{ V} \leq V_{DD} \leq 30\text{ V}$, FOD8480: $I_{F(ON)} = 6\text{ mA}$ to 10 mA , FOD8482: $I_{F(ON)} = 4\text{ mA}$ to 7 mA , $V_{F(OFF)} = 0$ to 0.8 V , unless otherwise specified. Typical value is measured at $T_A = 25^{\circ}\text{C}$ and $V_{DD} = 5\text{ V}$.)

Symbol	Parameter	Conditions	Min	Typ	Max	Units
V_F	Input Forward Voltage	$I_F = 10\text{ mA}$	1.1	1.5	1.8	V
$\Delta V_F / \Delta T_A$	Temperature Coefficient of Forward Voltage			-1.8		mV/ $^{\circ}\text{C}$
BV_R	Input Reverse Breakdown Voltage	$I_R = 10\ \mu\text{A}$	5.0			V
C_{IN}	Input Capacitance	$V_F = 0\text{ V}$, $f = 1\text{ MHz}$		20		pF
I_{OH}	High Level Output Current (Note 1)	$V_{OH} = V_{DD} - 3\text{ V}$	1.0			A
		$V_{OH} = V_{DD} - 6\text{ V}$	2.5			
I_{OL}	Low Level Output Current (Note 1)	$V_{OL} = V_{SS} + 3\text{ V}$	1.0			A
		$V_{OL} = V_{SS} + 6\text{ V}$	2.5			
V_{OH}	High Level Output Voltage (Notes 7, 8)	$I_F = 10\text{ mA}$, $I_O = -100\text{ mA}$	$V_{DD} - 0.5$	$V_{DD} - 0.1$		V
V_{OL}	Low Level Output Voltage (Notes 7, 8)	$I_F = 0\text{ mA}$, $I_O = 100\text{ mA}$		$V_{SS} + 0.1$	$V_{SS} + 0.5$	
I_{DDH}	High Output Supply Current	$V_O = \text{Open}$, $I_F = 10$ to 16 mA		2.9	4.0	mA
I_{DDL}	Low Output Supply Current	$V_O = \text{Open}$, $V_F = -3.0$ to 0.8 V		2.8	4.0	mA
I_{FLH}	Threshold Input Current Low to High	$I_O = 0\text{ mA}$, $V_O > 5\text{ V}$		2.0	7.5	mA
V_{FHL}	Threshold Input Voltage High to Low	$I_O = 0\text{ mA}$, $V_O < 5\text{ V}$	0.8			V
V_{UVLO+}	Under Voltage Lockout Threshold	$I_F = 10\text{ mA}$, $V_O > 5\text{ V}$	7.0	8.3	9.5	V
V_{UVLO-}		$I_F = 10\text{ mA}$, $V_O < 5\text{ V}$	6.5	7.7	9.0	
$UVLO_{HYS}$	Under Voltage Lockout Threshold Hysteresis			0.6		V

Product parametric performance is indicated in the Electrical Characteristics for the listed test conditions, unless otherwise noted. Product performance may not be indicated by the Electrical Characteristics if operated under different conditions.

7. In this test, V_{OH} is measured with a dc load current of 100 mA. When driving capacitive load V_{OH} will approach V_{DD} as I_{OH} approaches 0 A.

8. Maximum pulse width = 1 ms, maximum duty cycle = 20%.

FOD8342, FOD8342T

Table 8. SWITCHING CHARACTERISTICS (Apply over all recommended conditions, typical value is measured at $T_A = 25^\circ\text{C}$, $V_{SS} = \text{Ground}$ and $V_{DD} = 30\text{ V}$, unless otherwise specified.)

Symbol	Parameter	Conditions	Min	Typ	Max	Units
t_{PHL}	Propagation Delay Time to Logic Low Output (Note 9)	$I_F = 10\text{ mA}$, $R_g = 10\ \Omega$, $C_g = 10\text{ nF}$, $f = 250\text{ kHz}$, Duty Cycle = 50%	50	145	210	ns
t_{PLH}	Propagation Delay Time to Logic High Output (Note 10)		50	120	210	ns
PWD	Pulse Width Distortion, $ t_{PHL} - t_{PLH} $ (Note 11)			35	65	ns
PDD (Skew)	Propagation Delay Difference Between Any Two Parts (Note 12)		-90		90	
t_R	Output Rise Time (10% to 90%)			38		ns
t_F	Output Fall Time (90% to 10%)			24		ns
$t_{UVLO\ ON}$	ULVO Turn On Delay		$I_F = 10\text{ mA}$, $V_O > 5\text{ V}$		2.0	
$t_{UVLO\ OFF}$	ULVO Turn Off Delay	$I_F = 10\text{ mA}$, $V_O < 5\text{ V}$		0.3		μs
$ CM_H $	Common Mode Transient Immunity at Output High	$V_{DD} = 30\text{ V}$, $I_F = 10\text{ mA}$ to 16 mA , $V_{CM} = 2000\text{ V}$, $T_A = 25^\circ\text{C}$ (Note 13)	20	50		$\text{kV}/\mu\text{s}$
$ CM_L $	Common Mode Transient Immunity at Output Low	$V_{DD} = 30\text{ V}$, $V_F = 0\text{ V}$, $V_{CM} = 2000\text{ V}$, $T_A = 25^\circ\text{C}$ (Note 14)	20	50		$\text{kV}/\mu\text{s}$

9. Propagation delay t_{PHL} is measured from the 50% level on the falling edge of the input pulse to the 50% level of the falling edge of the V_O signal.
10. Propagation delay t_{PLH} is measured from the 50% level on the rising edge of the input pulse to the 50% level of the rising edge of the V_O signal.
11. PWD is defined as $|t_{PHL} - t_{PLH}|$ for any given device.
12. The difference between t_{PHL} and t_{PLH} between any two FOD8342 parts under the same operating conditions, with equal loads.
13. Common mode transient immunity at output high is the maximum tolerable negative dV_{cm}/dt on the trailing edge of the common mode impulse signal, V_{CM} , to ensure that the output remains high (i.e., $V_O > 15.0\text{ V}$).
14. Common mode transient immunity at output low is the maximum tolerable positive dV_{cm}/dt on the leading edge of the common pulse signal, V_{CM} , to ensure that the output remains low (i.e., $V_O < 1.0\text{ V}$).

FOD8342, FOD8342T

TYPICAL CHARACTERISTICS

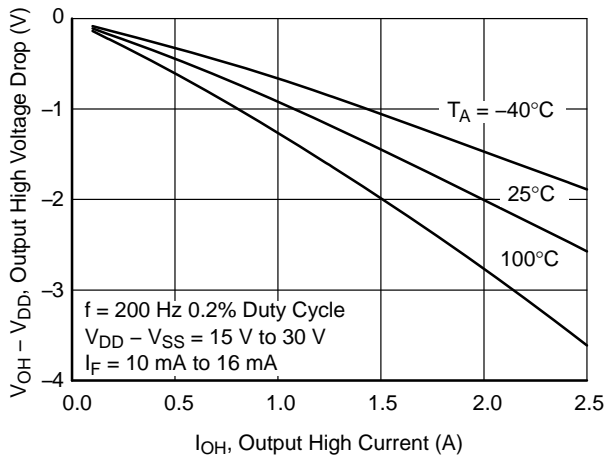

Figure 2. Output High Voltage Drop vs. Output High Current

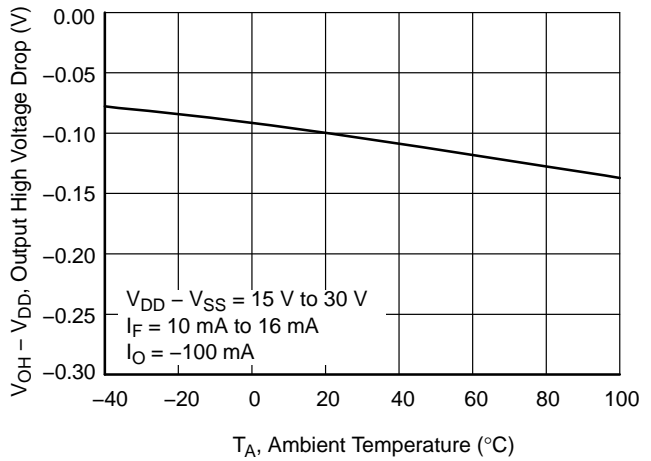

Figure 3. Output High Voltage Drop vs. Ambient Temperature

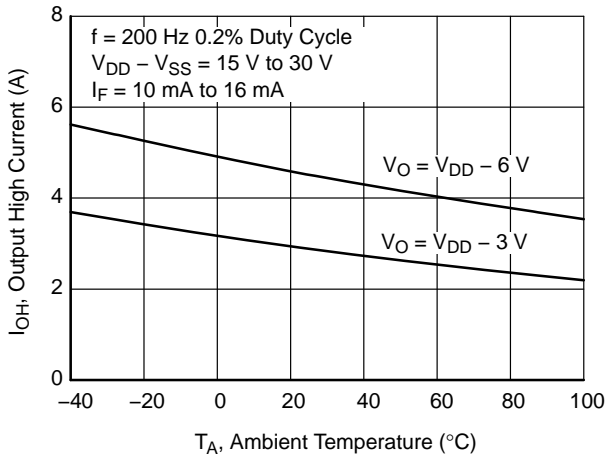

Figure 4. Output High Current vs. Ambient Temperature

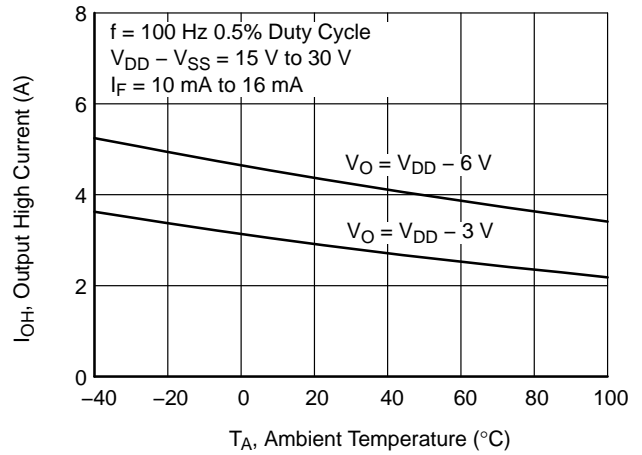

Figure 5. Output High Current vs. Ambient Temperature

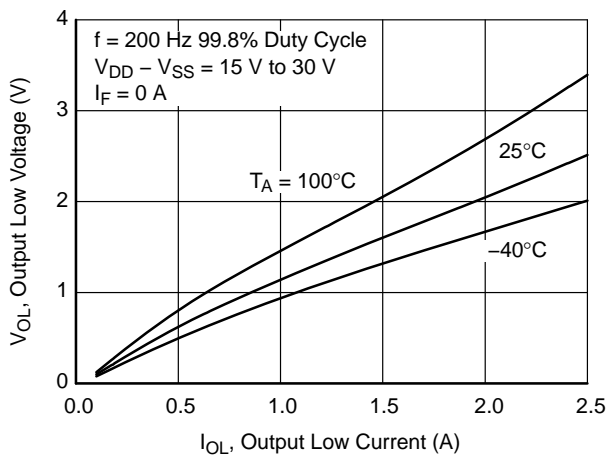

Figure 6. Output Low Voltage vs. Output Low Current

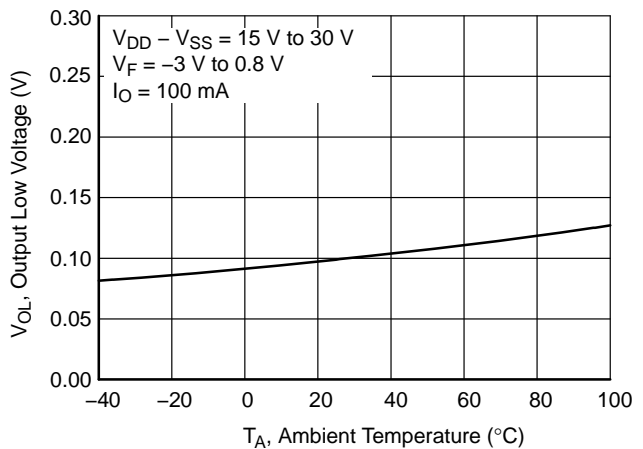

Figure 7. Output Low Voltage vs. Ambient Temperature

TYPICAL CHARACTERISTICS (CONTINUED)

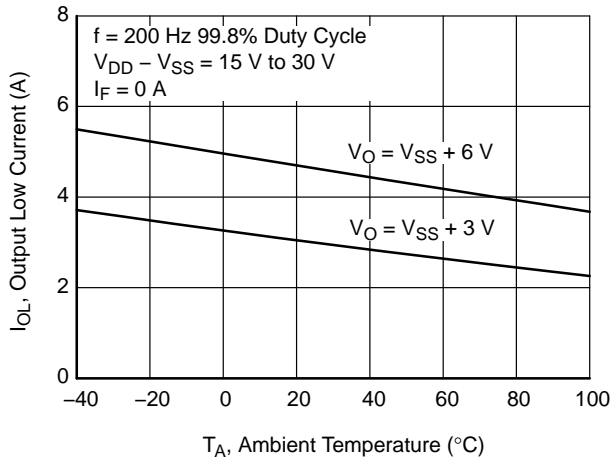

Figure 8. Output Low Current vs. Ambient Temperature

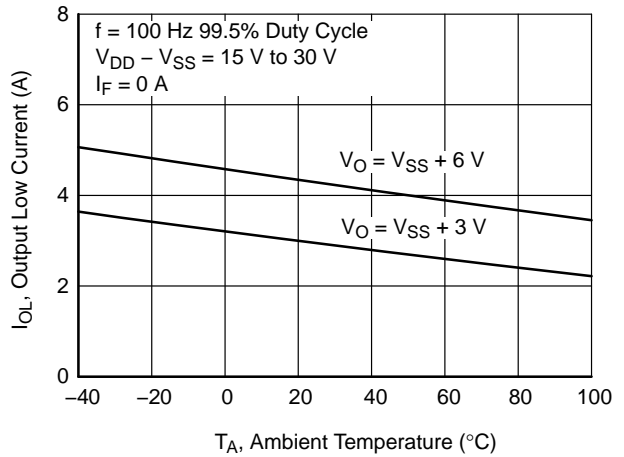

Figure 9. Output Low Current vs. Ambient Temperature

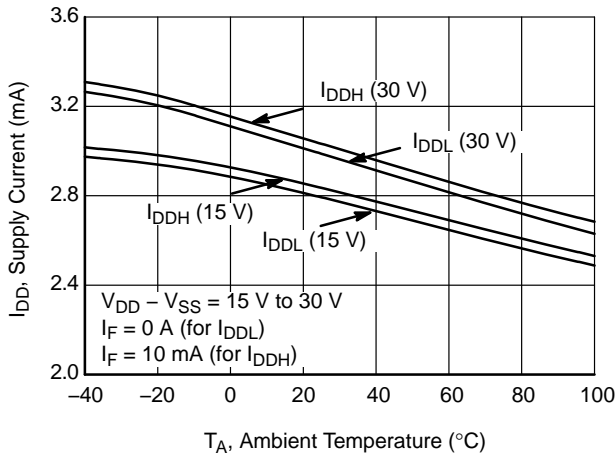

Figure 10. Supply Current vs. Ambient Temperature

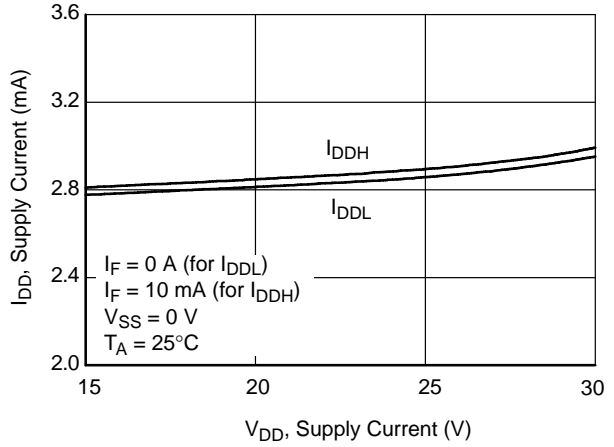

Figure 11. Supply Current vs. Supply Voltage

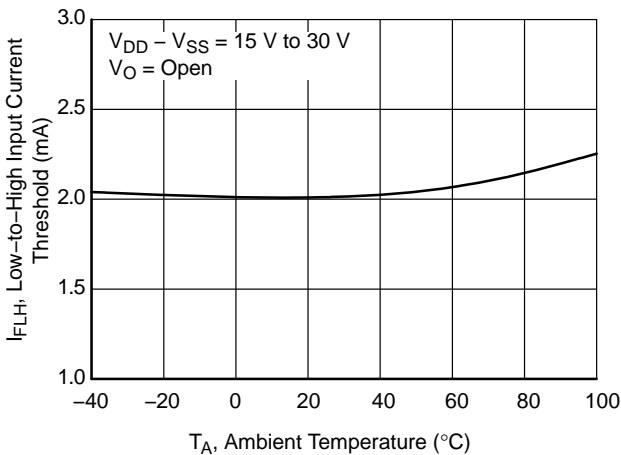

Figure 12. Low-to-High Input Current Threshold vs. Ambient Temperature

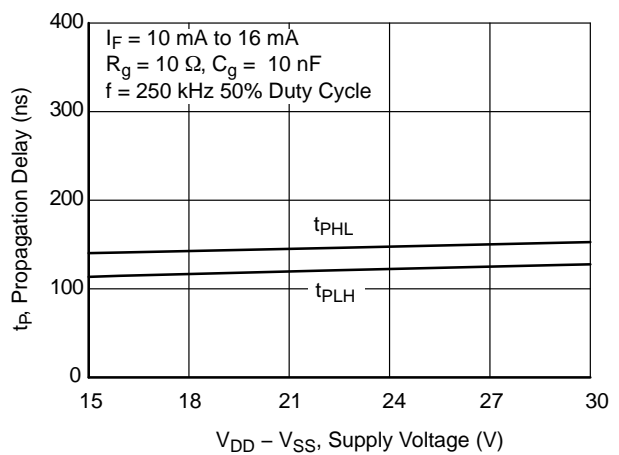

Figure 13. Propagation Delay vs. Supply Voltage

FOD8342, FOD8342T

TYPICAL CHARACTERISTICS (CONTINUED)

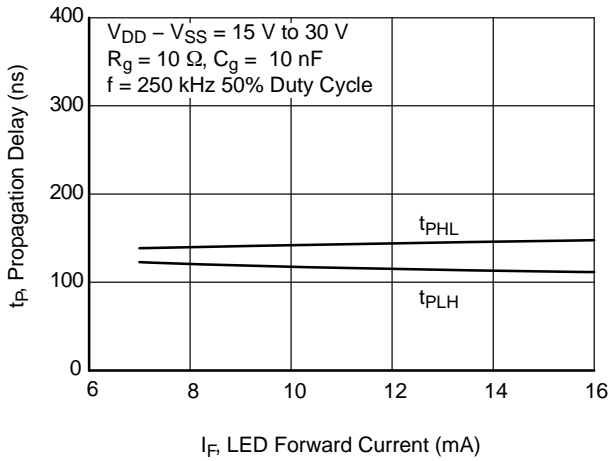

Figure 14. Propagation Delay vs. LED Forward Current

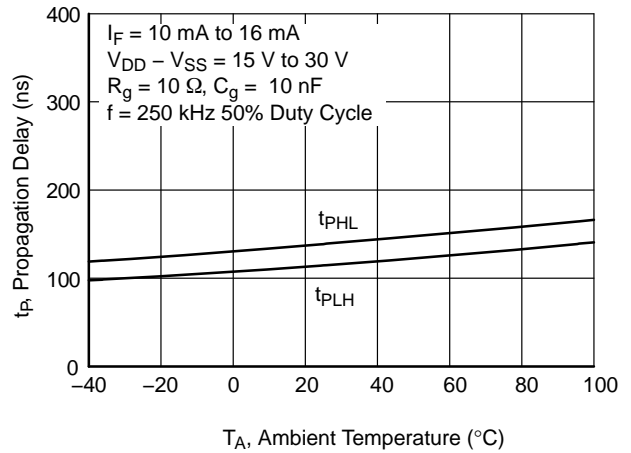

Figure 15. Propagation Delay vs. Ambient Temperature

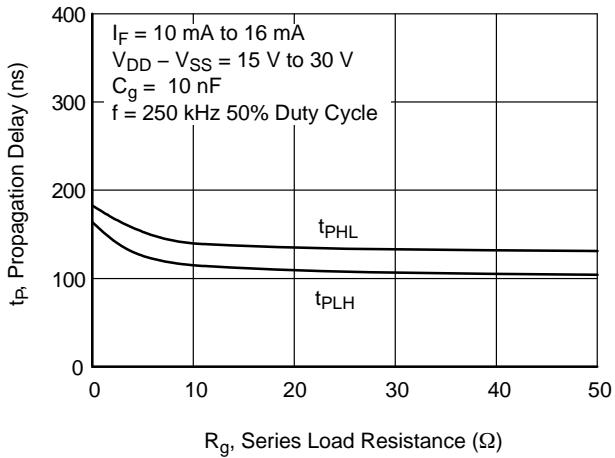

Figure 16. Propagation Delay vs. Series Load Resistance

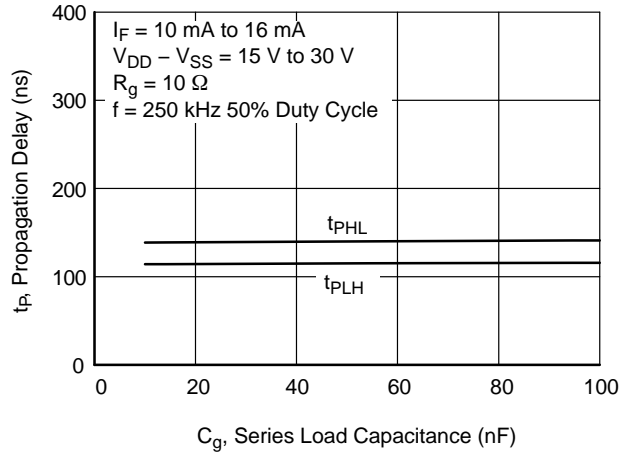

Figure 17. Propagation Delay vs. Series Load Capacitance

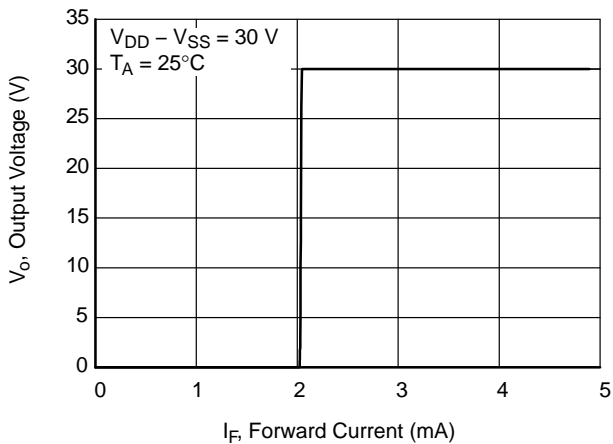

Figure 18. Transfer Characteristics

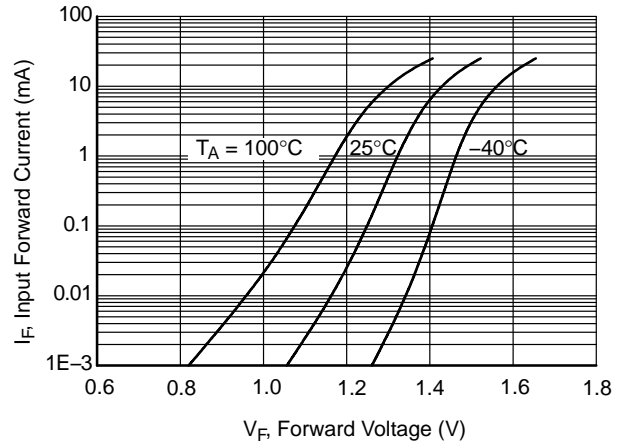

Figure 19. Input Forward Current vs. Forward Voltage

FOD8342, FOD8342T

TYPICAL CHARACTERISTICS (CONTINUED)

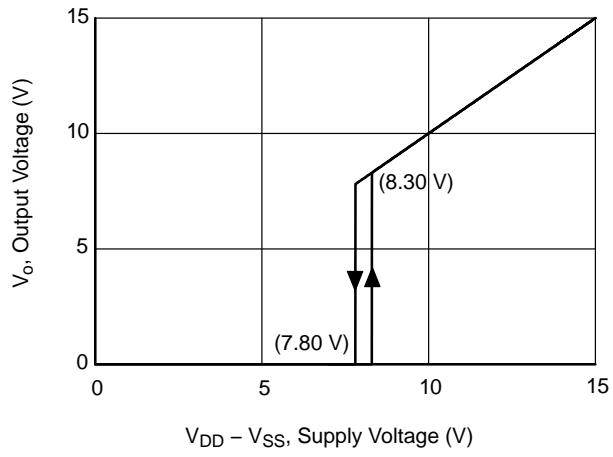

Figure 20. Under Voltage Lockout

FOD8342, FOD8342T

TEST CIRCUIT

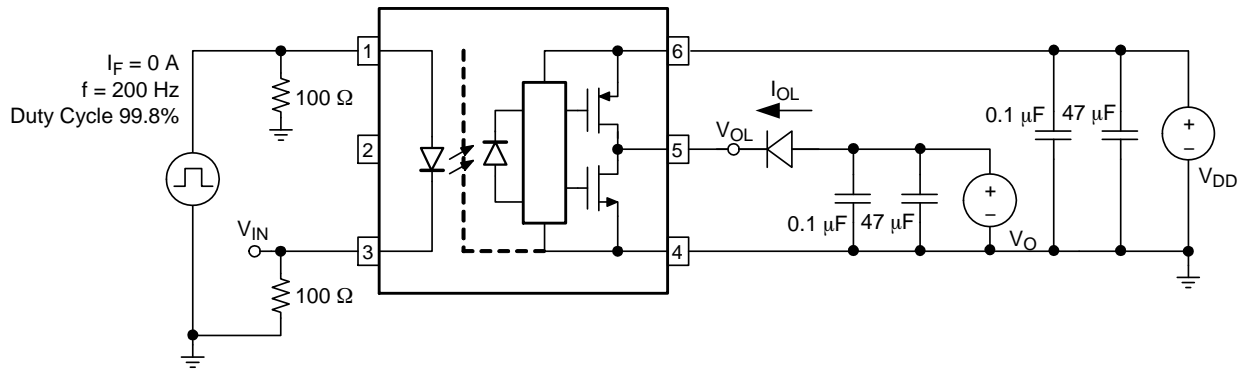

Figure 21. I_{OL} Test Circuit

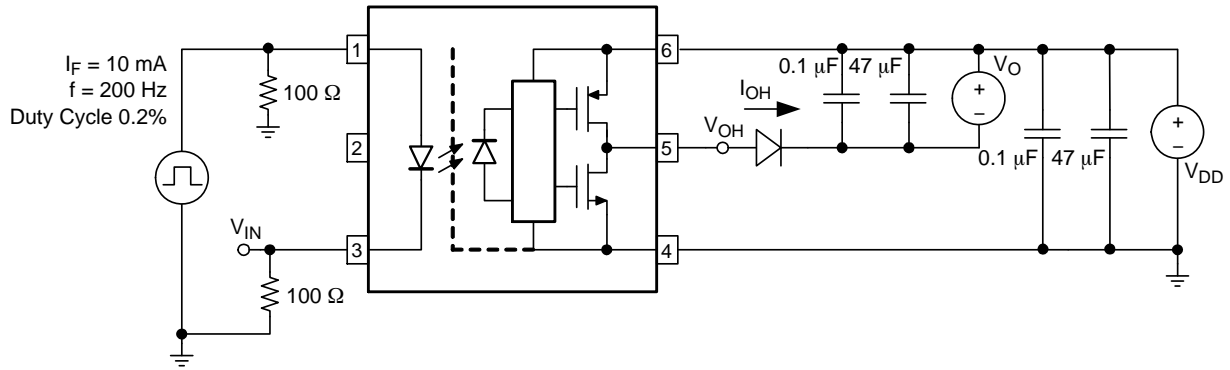

Figure 22. I_{OH} Test Circuit

FOD8342, FOD8342T

TEST CIRCUIT (CONTINUED)

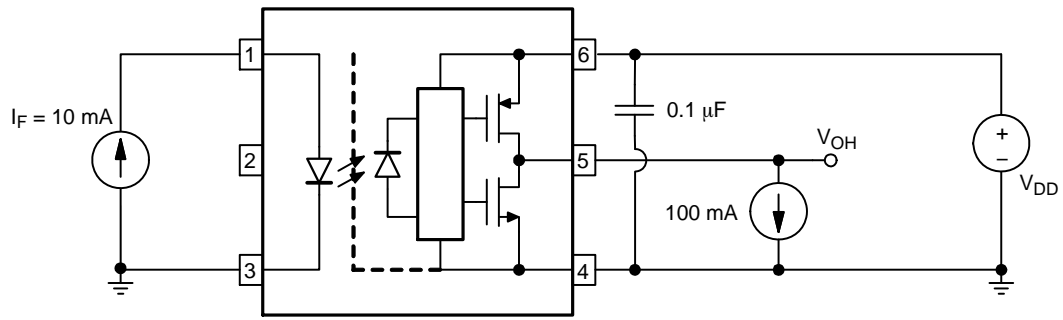

Figure 23. V_{OH} Test Circuit

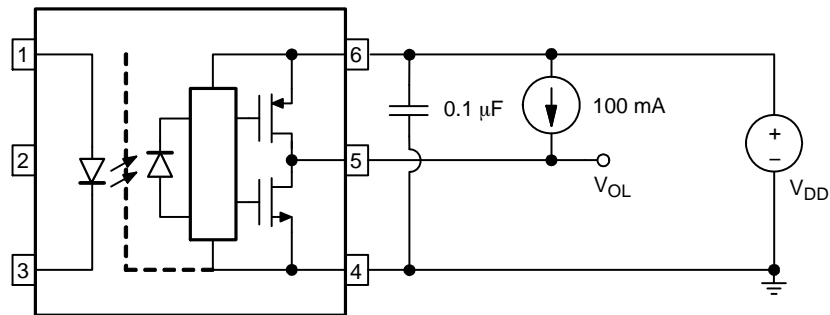

Figure 24. V_{OL} Test Circuit

FOD8342, FOD8342T

TEST CIRCUIT (CONTINUED)

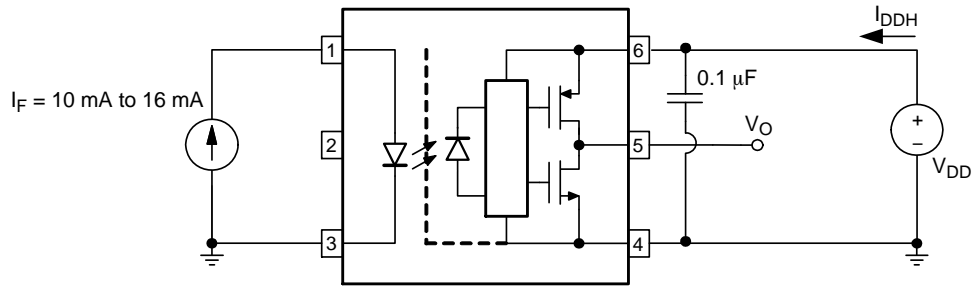

Figure 25. I_{DDH} Test Circuit

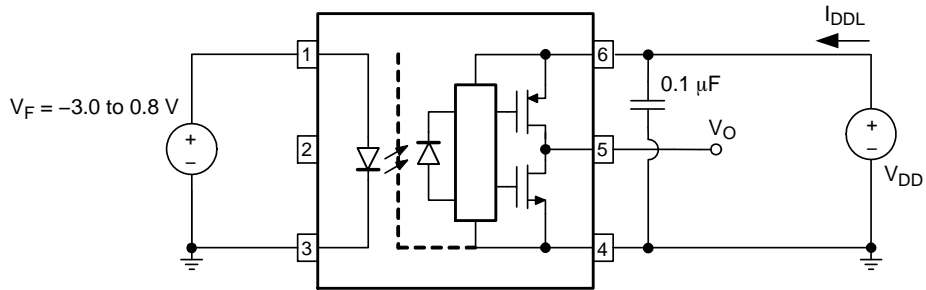
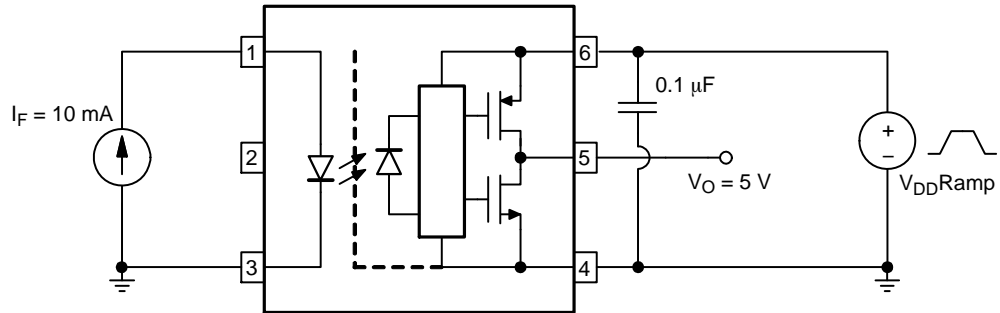
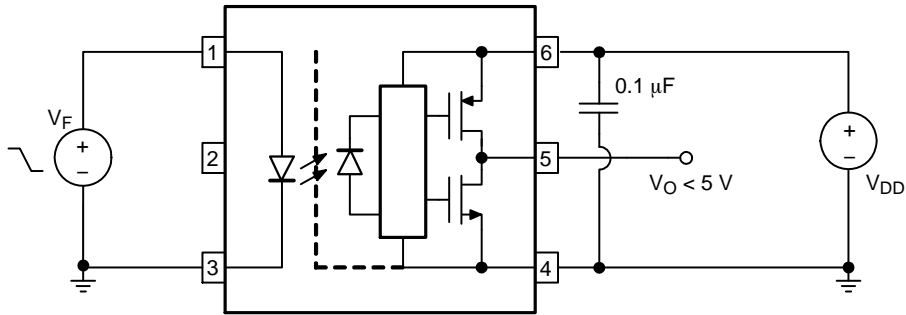
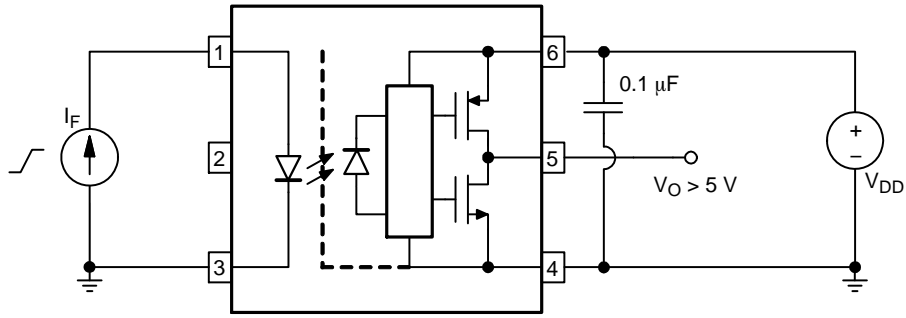

Figure 26. I_{DDL} Test Circuit

FOD8342, FOD8342T

TEST CIRCUIT (CONTINUED)



FOD8342, FOD8342T

TEST CIRCUIT (CONTINUED)

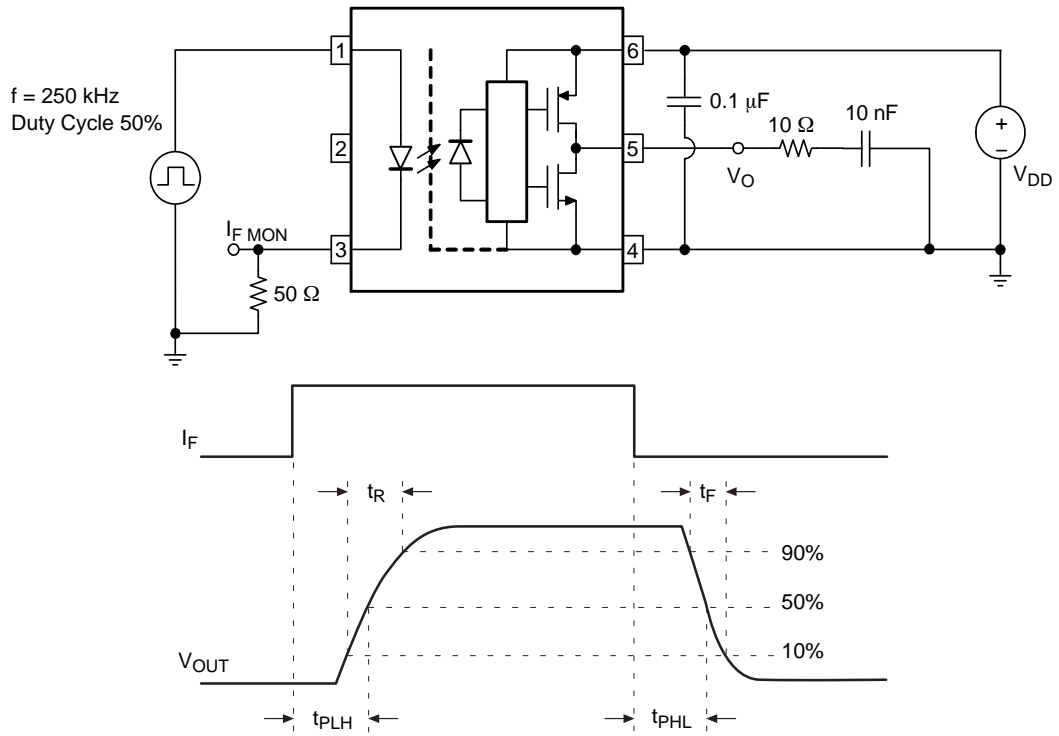
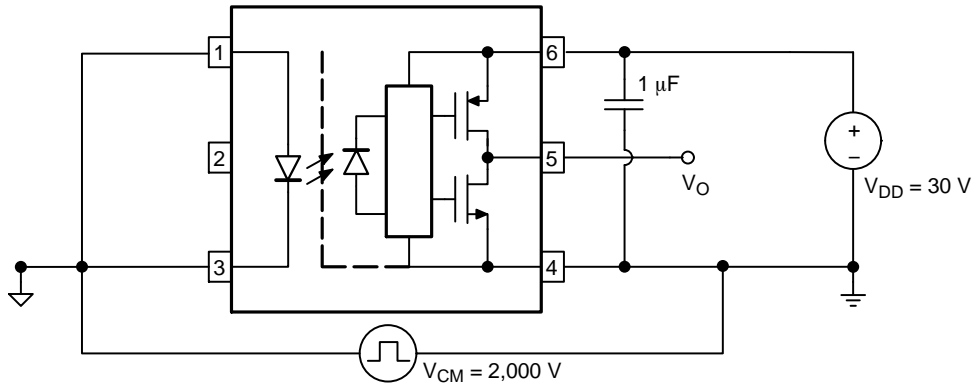

Figure 30. t_{PHL} , t_{PLH} , t_R and t_F Test Circuit and Waveforms

FOD8342, FOD8342T

TEST CIRCUIT (CONTINUED)



Common-Mode Low (CML) Test Circuit

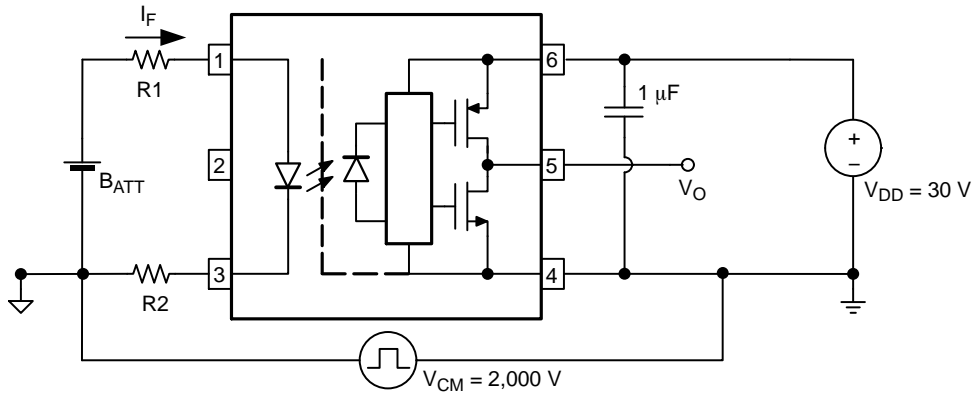

Common-Mode High (CMH) Test Circuit

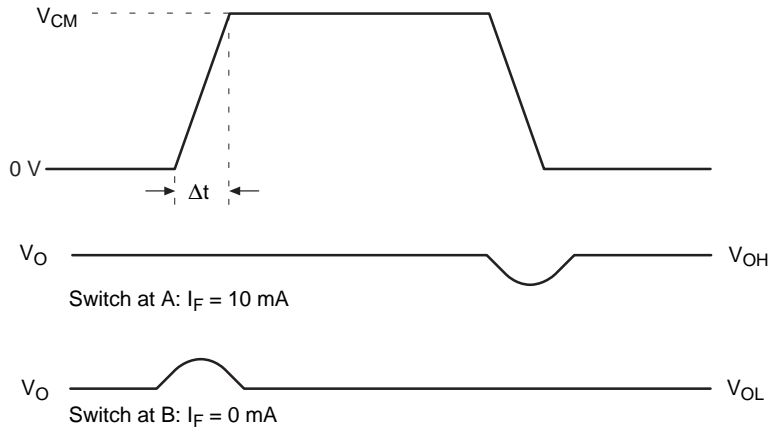
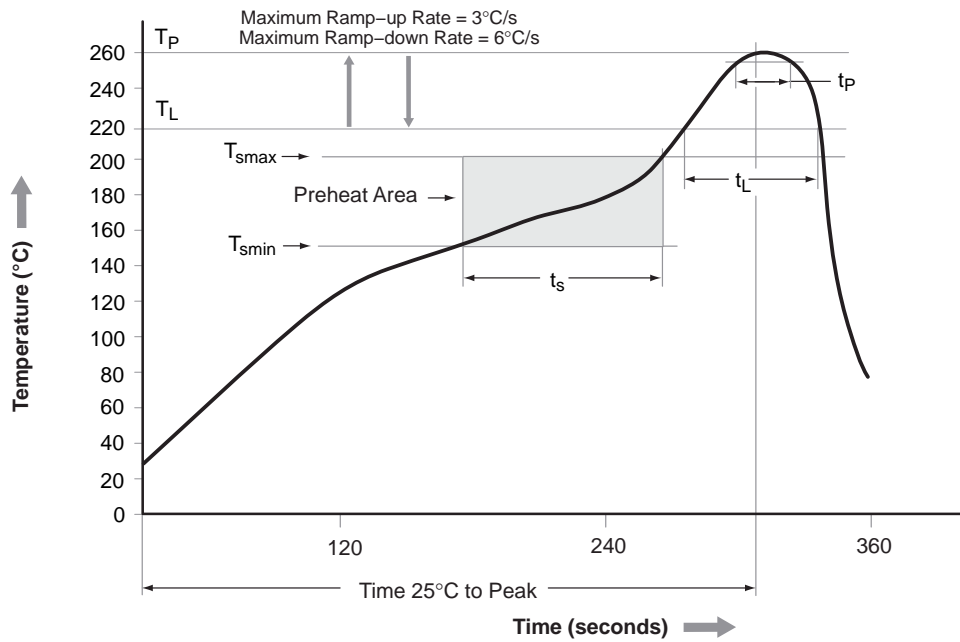

Figure 31. CMR Test Circuit and Waveforms

REFLOW PROFILE



Profile Feature	Pb-Free Assembly Profile
Temperature Minimum (T_{smin})	150°C
Temperature Maximum (T_{smax})	200°C
Time (t_s) from (T_{smin} to T_{smax})	60 s to 120 s
Ramp-up Rate (t_L to t_p)	3°C/s maximum
Liquidous Temperature (T_L)	217°C
Time (t_L) Maintained Above (T_L)	60 s to 150 s
Peak Body Package Temperature	260°C +0°C / -5°C
Time (t_p) within 5°C of 260°C	30 s
Ramp-Down Rate (T_P to T_L)	6°C/s maximum
Time 25°C to Peak Temperature	8 minutes maximum

Figure 32. Reflow Profile

FOD8342, FOD8342T

ORDERING INFORMATION

Part Number	Package	Packing Method
FOD8342	Stretched Body SOP 6-Pin	Tube (100 units per tube)
FOD8342R2	Stretched Body SOP 6-Pin	Tape and Reel (1,000 units per reel)
FOD8342V	Stretched Body SOP 6-Pin, DIN EN/IEC60747-5-5 Option	Tube (100 units per tube)
FOD8342R2V	Stretched Body SOP 6-Pin, DIN EN/ IEC60747-5-5 Option	Tape and Reel (1,000 units per reel)
FOD8342T	Stretched Body SOP 6-Pin, Wide Lead	Tube (100 units per tube)
FOD8342TR2	Stretched Body SOP 6-Pin, Wide Lead	Tape and Reel (1,000 units per reel)
FOD8342TV	Stretched Body SOP 6-Pin, Wide Lead, DIN EN/IEC60747-5-5 Option	Tube (100 units per tube)
FOD8342TR2V	Stretched Body SOP 6-Pin, Wide Lead, DIN EN/ IEC60747-5-5 Option	Tape and Reel (1,000 units per reel)

*All packages are lead free per JEDEC: J-STD-020B standard.

MECHANICAL CASE OUTLINE
PACKAGE DIMENSIONS

ON Semiconductor®



SOIC6
CASE 751EL
ISSUE O

DATE 30 SEP 2016

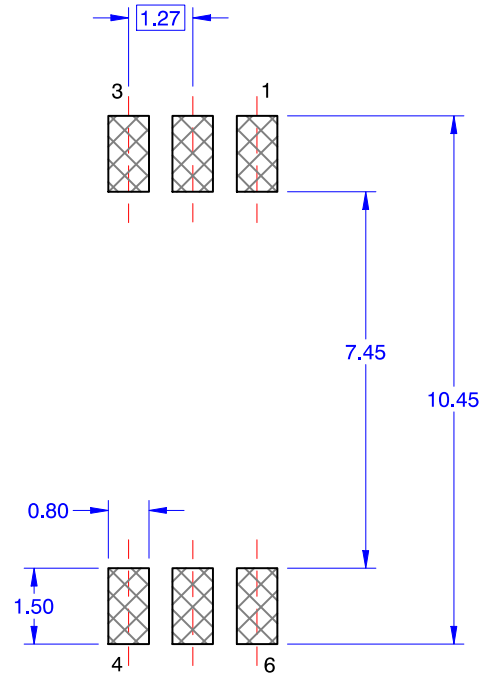
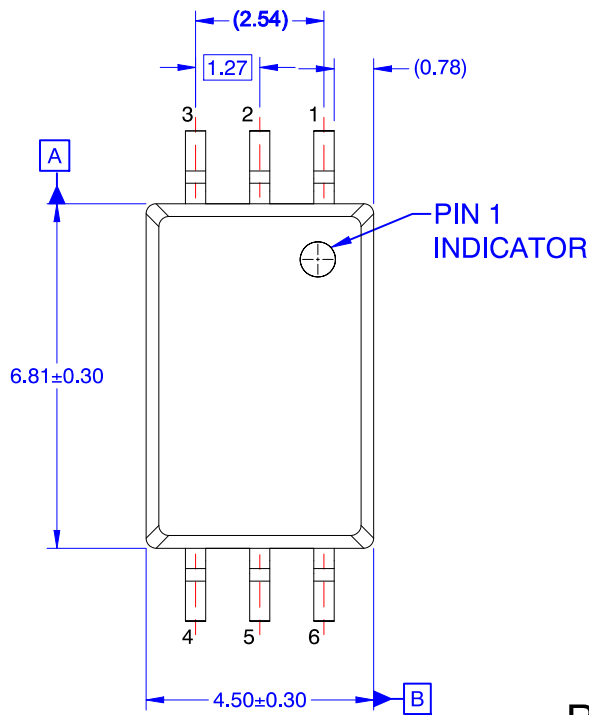

RECOMMENDED LAND PATTERN

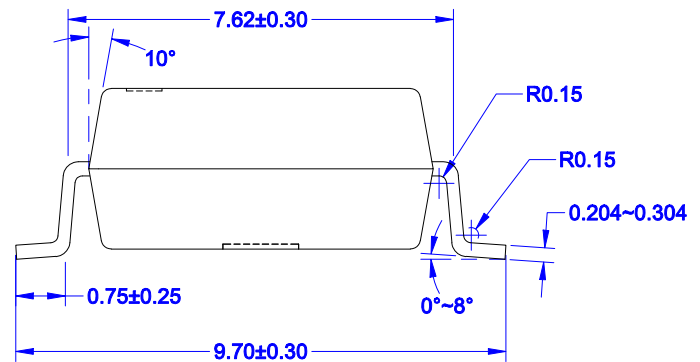
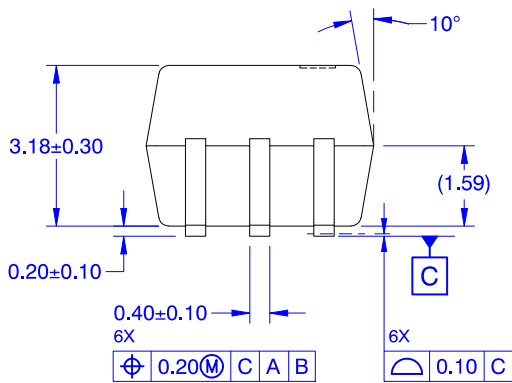

NOTES: UNLESS OTHERWISE SPECIFIED

- A) NO STANDARD APPLIES TO THIS PACKAGE
- B) ALL DIMENSIONS ARE IN MILLIMETERS.
- C) DIMENSIONS DO NOT INCLUDE BURRS OR MOLD FLASH, AND TIE BAR EXTRUSION.
- D) DIMENSIONING AND TOLERANCING PER ASME Y14.5M-2009.

DOCUMENT NUMBER:	98AON13745G	Electronic versions are uncontrolled except when accessed directly from the Document Repository. Printed versions are uncontrolled except when stamped "CONTROLLED COPY" in red.
DESCRIPTION:	SOIC6	PAGE 1 OF 1

ON Semiconductor and are trademarks of Semiconductor Components Industries, LLC dba ON Semiconductor or its subsidiaries in the United States and/or other countries. ON Semiconductor reserves the right to make changes without further notice to any products herein. ON Semiconductor makes no warranty, representation or guarantee regarding the suitability of its products for any particular purpose, nor does ON Semiconductor assume any liability arising out of the application or use of any product or circuit, and specifically disclaims any and all liability, including without limitation special, consequential or incidental damages. ON Semiconductor does not convey any license under its patent rights nor the rights of others.

SOIC6 W
CASE 751EM
ISSUE O

DATE 30 SEP 2016

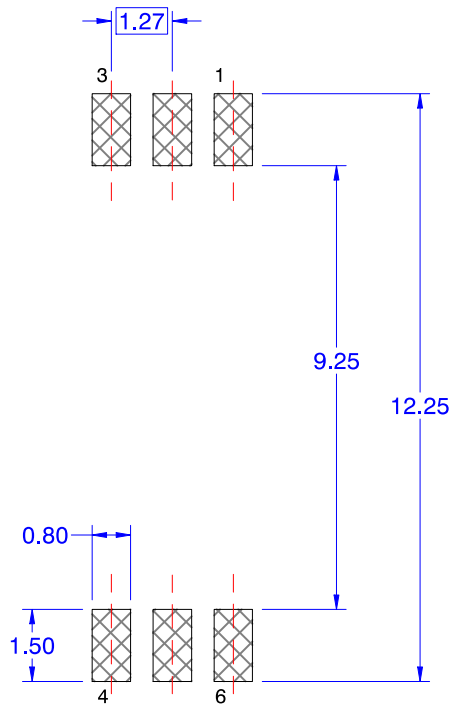
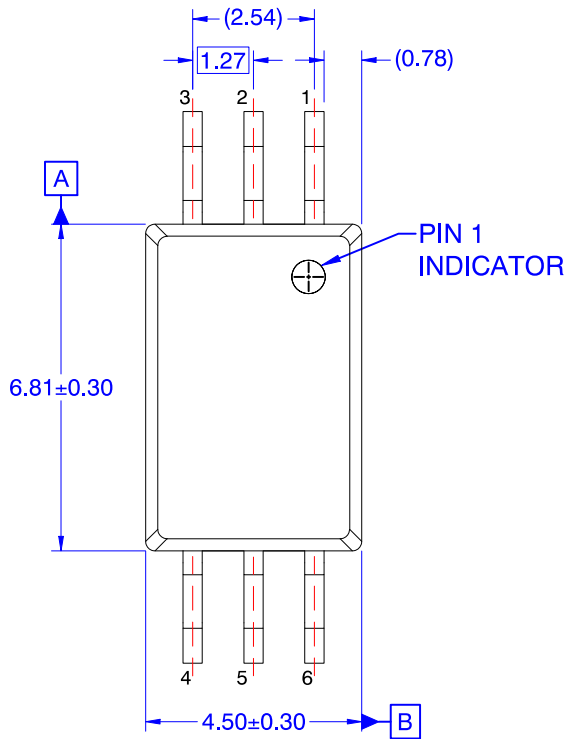

RECOMMENDED LAND PATTERN

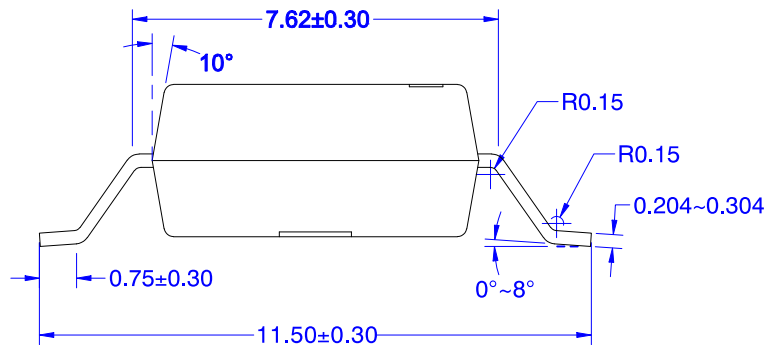
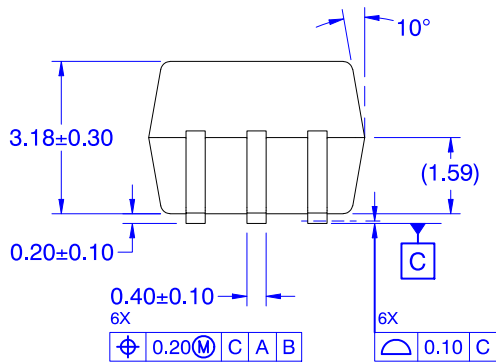

- NOTES: UNLESS OTHERWISE SPECIFIED**
- A) NO STANDARD APPLIES TO THIS PACKAGE
 - B) ALL DIMENSIONS ARE IN MILLIMETERS.
 - C) DIMENSIONS DO NOT INCLUDE BURRS OR MOLD FLASH, AND TIE BAR EXTRUSION.
 - D) DIMENSIONING AND TOLERANCING PER ASME Y14.5M-2009.

DOCUMENT NUMBER:	98AON13749G	Electronic versions are uncontrolled except when accessed directly from the Document Repository. Printed versions are uncontrolled except when stamped "CONTROLLED COPY" in red.
DESCRIPTION:	SOIC6 W	PAGE 1 OF 1

ON Semiconductor and are trademarks of Semiconductor Components Industries, LLC dba ON Semiconductor or its subsidiaries in the United States and/or other countries. ON Semiconductor reserves the right to make changes without further notice to any products herein. ON Semiconductor makes no warranty, representation or guarantee regarding the suitability of its products for any particular purpose, nor does ON Semiconductor assume any liability arising out of the application or use of any product or circuit, and specifically disclaims any and all liability, including without limitation special, consequential or incidental damages. ON Semiconductor does not convey any license under its patent rights nor the rights of others.

onsemi, **Onsemi**, and other names, marks, and brands are registered and/or common law trademarks of Semiconductor Components Industries, LLC dba "**onsemi**" or its affiliates and/or subsidiaries in the United States and/or other countries. **onsemi** owns the rights to a number of patents, trademarks, copyrights, trade secrets, and other intellectual property. A listing of **onsemi**'s product/patent coverage may be accessed at www.onsemi.com/site/pdf/Patent-Marking.pdf. **onsemi** reserves the right to make changes at any time to any products or information herein, without notice. The information herein is provided "as-is" and **onsemi** makes no warranty, representation or guarantee regarding the accuracy of the information, product features, availability, functionality, or suitability of its products for any particular purpose, nor does **onsemi** assume any liability arising out of the application or use of any product or circuit, and specifically disclaims any and all liability, including without limitation special, consequential or incidental damages. Buyer is responsible for its products and applications using **onsemi** products, including compliance with all laws, regulations and safety requirements or standards, regardless of any support or applications information provided by **onsemi**. "Typical" parameters which may be provided in **onsemi** data sheets and/or specifications can and do vary in different applications and actual performance may vary over time. All operating parameters, including "Typicals" must be validated for each customer application by customer's technical experts. **onsemi** does not convey any license under any of its intellectual property rights nor the rights of others. **onsemi** products are not designed, intended, or authorized for use as a critical component in life support systems or any FDA Class 3 medical devices or medical devices with a same or similar classification in a foreign jurisdiction or any devices intended for implantation in the human body. Should Buyer purchase or use **onsemi** products for any such unintended or unauthorized application, Buyer shall indemnify and hold **onsemi** and its officers, employees, subsidiaries, affiliates, and distributors harmless against all claims, costs, damages, and expenses, and reasonable attorney fees arising out of, directly or indirectly, any claim of personal injury or death associated with such unintended or unauthorized use, even if such claim alleges that **onsemi** was negligent regarding the design or manufacture of the part. **onsemi** is an Equal Opportunity/Affirmative Action Employer. This literature is subject to all applicable copyright laws and is not for resale in any manner.

ADDITIONAL INFORMATION

TECHNICAL PUBLICATIONS:

Technical Library: www.onsemi.com/design/resources/technical-documentation
onsemi Website: www.onsemi.com

ONLINE SUPPORT: www.onsemi.com/support

For additional information, please contact your local Sales Representative at www.onsemi.com/support/sales

Looking for pricing, stock, or lifecycle information?

Click below to explore more details on WIN SOURCE:

- ⊖ [View FOD8342T on WIN SOURCE](#)
- ⊖ [ON Semiconductor Information](#)

Optimize Your Supply Chain with WIN SOURCE Solutions

- ✓ Global Sourcing Solution
- ✓ Obsolete Management
- ✓ Cost Control Management
- ✓ Shortage Management
- ✓ Alternative Solution
- ✓ Excess Inventory Management