



# THE DATASHEET OF FOD819S



# FOD819 Series

## FOD819 4-Pin DIP High Speed Phototransistor Optocouplers

### Description

The FOD819 consists of a gallium arsenide (GaAs) infra-red emitting diode, driving a high speed photo detector with integrated base-to-emitter resistor,  $R_{BE}$ , in a 4-pin dual-in-line package. It is designed to be an improved replacement to the popular FOD817 Series when higher speed performance is required in isolated data signal transmission.

### Features

- High Speed Performance ~ 30 kHz
- Current Transfer Ratio: 100% to 600%
- Minimum  $BV_{CEO}$  of 80 V Guaranteed
- Safety and Regulatory Approvals:
  - UL1577, 5,000 VAC<sub>RMS</sub> for 1 Minute
  - DIN EN/IEC60747-5-5, 850 V Peak Working Insulation Voltage

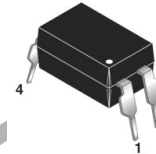
### Typical Applications

- Digital Logic Inputs
- Microprocessor Inputs
- Power Supply Monitor
- Twisted Pair Line Receiver
- Telephone Line Receiver



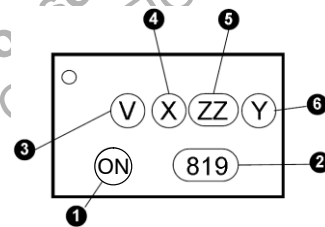
ON Semiconductor®

[www.onsemi.com](http://www.onsemi.com)



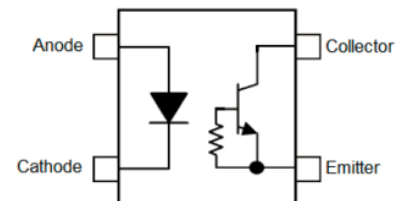
DIP 4 PINS

### MARKING DIAGRAM



- 1. ON = Company Logo
- 2. 819 = Device Number
- 3. V = DIN EN/IEC60747-5-5 Option
- 4. X = One-Digit Year Code
- 5. ZZ = Digit Work Week
- 6. Y = Assembly Package Code

### PIN CONNECTIONS



### ORDERING INFORMATION

See detailed ordering and shipping information on page 7 of this data sheet.

## FOD819 Series

### Safety and Insulation Ratings

As per DIN EN/IEC 60747-5-5, this optocoupler is suitable for “safe electrical insulation” only within the safety limit data. Compliance with the safety ratings shall be ensured by means of protective circuits.

**Table 1. SAFETY AND INSULATION RATINGS**

Parameter		Characteristics
Installation Classifications per DIN VDE 0110/1.89 Table 1, For Rated Mains Voltage	< 150 V <sub>RMS</sub>	I-IV
	< 300 V <sub>RMS</sub>	I-III
Climatic Classification		55/115/21
Pollution Degree (DIN VDE 0110/1.89)		2
Comparative Tracking Index		175

**Table 2.**

Symbol	Parameter	Value	Unit
V <sub>PR</sub>	Input-to-Output Test Voltage, Method A, V <sub>IORM</sub> × 1.6 = V <sub>PR</sub> , Type and Sample Test with t <sub>m</sub> = 10 s, Partial Discharge < 5 pC	1360	V <sub>peak</sub>
	Input-to-Output Test Voltage, Method B, V <sub>IORM</sub> × 1.875 = V <sub>PR</sub> , 100% Production Test with t <sub>m</sub> = 1 s, Partial Discharge < 5 pC	1594	V <sub>peak</sub>
V <sub>IORM</sub>	Maximum Working Insulation Voltage	850	V <sub>peak</sub>
V <sub>IOTM</sub>	Highest Allowable Over-Voltage	8000	V <sub>peak</sub>
	External Creepage	≥ 7	mm
	External Clearance	≥ 7	mm
	External Clearance (for Option W, 0.4" Lead Spacing)	≥ 10	mm
DTI	Distance Through Insulation (Insulation Thickness)	≥ 0.4	mm
T <sub>S</sub>	Case Temperature (Note 1)	175	°C
I <sub>S,INPUT</sub>	Input Current (Note 1)	400	mA
P <sub>S,OUTPUT</sub>	Output Power (Note 1)	700	mW
R <sub>IO</sub>	Insulation Resistance at T <sub>S</sub> , V <sub>IO</sub> = 500 V (Note 1)	> 10 <sup>11</sup>	Ω

1. Safety limit values – maximum values allowed in the event of a failure.

**Table 3. ABSOLUTE MAXIMUM RATINGS**

Symbol	Parameter	Value	Unit
<b>TOTAL PACKAGE</b>			
T <sub>STG</sub>	Storage Temperature	-55 to +125	°C
T <sub>OPR</sub>	Operating Temperature	-55 to +110	°C
T <sub>J</sub>	Junction Temperature	-55 to +125	°C
T <sub>SOL</sub>	Lead Solder Temperature	260 for 10 seconds	°C
θ <sub>JC</sub>	Junction-to-Case Thermal Resistance	210	°C/W
P <sub>TOT</sub>	Total Device Power Dissipation	200	mW
<b>EMITTER</b>			
I <sub>F</sub>	Continuous Forward Current	50	mA
V <sub>R</sub>	Reverse Voltage	6	V
P <sub>D</sub>	Power Dissipation	70	mW
	Derate Above 100°C	1.7	mW/°C

# FOD819 Series

**Table 3. ABSOLUTE MAXIMUM RATINGS** (continued)

Symbol	Parameter	Value	Unit
<b>DETECTOR</b>			
$V_{CEO}$	Collector–Emitter Voltage	80	V
$V_{ECO}$	Emitter–Collector Voltage	2	V
$I_C$	Continuous Collector Current	30	mA
$P_C$	Collector Power Dissipation	150	mW
	Derate Above 90°C	2.9	mW/°C

Stresses exceeding those listed in the Maximum Ratings table may damage the device. If any of these limits are exceeded, device functionality should not be assumed, damage may occur and reliability may be affected.

## Electrical Characteristics

**Table 4. INDIVIDUAL COMPONENT CHARACTERISTICS** ( $T_A = 25^\circ\text{C}$  unless otherwise specified)

Symbol	Parameter	Test Conditions	Min.	Typ.	Max.	Unit
<b>EMITTER</b>						
$V_F$	Forward Voltage	$I_F = 1.5\text{ mA}$		1.2	1.4	V
$I_R$	Reverse Current	$V_R = 4.0\text{ V}$			10	$\mu\text{A}$
$C_t$	Terminal Capacitance	$V = 0, f = 1\text{ kHz}$		30		pF
<b>DETECTOR</b>						
$I_{CEO}$	Collector Dark Current	$V_{CE} = 40\text{ V}, I_F = 0$			100	nA
$BV_{CEO}$	Collector–Emitter Breakdown Voltage	$I_C = 0.1\text{ mA}, I_F = 0$	80	150		V
$BV_{ECO}$	Emitter–Collector Breakdown Voltage	$I_E = 0.1\text{ mA}, I_F = 0$	2	7		V

### DC TRANSFER CHARACTERISTICS

CTR	Current Transfer Ratio (Note 2)	$I_F = 1.5\text{ mA}, V_{CE} = 5\text{ V}$	100		600	%
$V_{CE(SAT)}$	Saturation Voltage	$I_F = 1.5\text{ mA}, I_C = 0.2\text{ mA}$			0.3	V
$I_{C(OFF)}$	OFF–state collector current	$V_F = 0.7\text{ V}, V_{CE} = 40\text{ V}$			10	$\mu\text{A}$

### AC TRANSFER CHARACTERISTICS

$t_R$	Rise Time (Saturated)	$I_F = 1.5\text{ mA}, V_{CC} = 5\text{ V}, R_L = 10\text{ k}\Omega$ (Note 3)		12		$\mu\text{s}$
$t_F$	Fall Time (Saturated)			20		$\mu\text{s}$
$t_{PHL}$	Propagation Delay Time High–to–Low	$I_F = 1.5\text{ mA}, V_{CC} = 5\text{ V}, R_L = 10\text{ k}\Omega$ (Note 3)		9	30	$\mu\text{s}$
$t_{PLH}$	Propagation Delay Time Low–to–High			18	30	$\mu\text{s}$

- Current Transfer Ratio (CTR) =  $I_C / I_F \times 100\%$ .
- Refer to test circuit setup.

**Table 5. ISOLATION CHARACTERISTICS** ( $T_A = 25^\circ\text{C}$  unless otherwise specified)

Symbol	Parameter	Test Conditions	Min.	Typ.	Max.	Unit
$V_{ISO}$	Input–Output Isolation Voltage (Note 4)	$f = 60\text{ Hz}, t = 1\text{ minutes},$ $I_{I-O} \leq 2\text{ }\mu\text{A}$	5000			$V_{AC(RMS)}$
$R_{ISO}$	Isolation Resistance	$V_{I-O} = 500\text{ V}_{DC}$		$1 \times 10^{11}$		$\Omega$
$C_{ISO}$	Isolation Capacitance	$V_{I-O} = 0, f = 1\text{ MHz}$		0.6	1.0	pf

- For this test, Pins 1 and 2 are common, and Pins 3 and 4 are common.

Typical Performance Curves

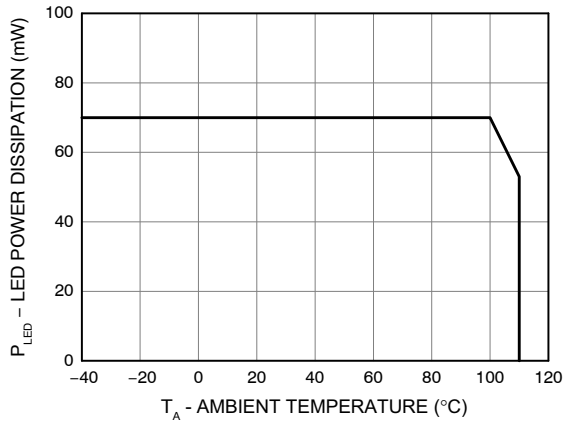


Figure 1. LED Power Dissipation vs. Ambient Temperature

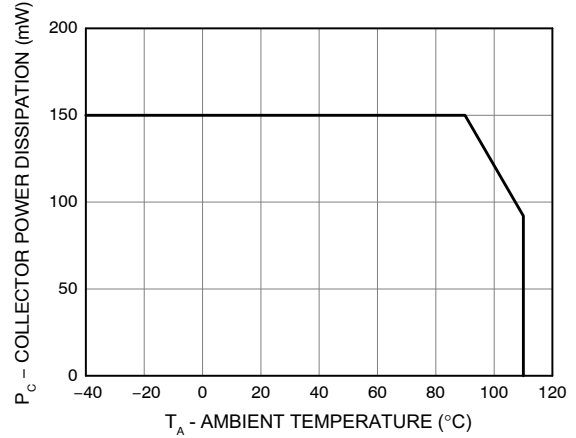


Figure 2. Collector Power Dissipation vs. Ambient Temperature

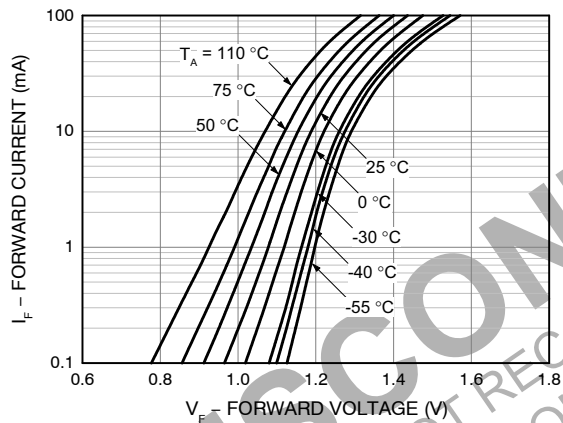


Figure 3. Forward Current vs. Forward Voltage

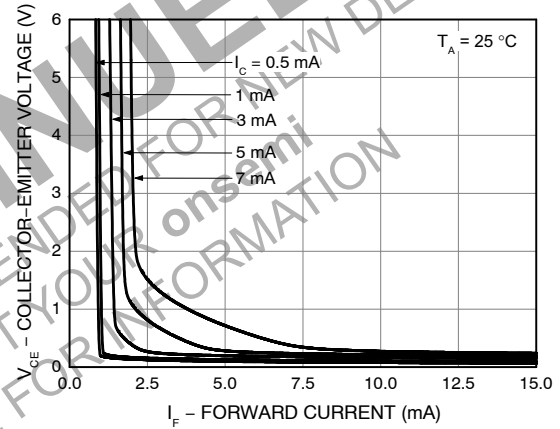


Figure 4. Collector-Emitter Voltage vs. Forward Current

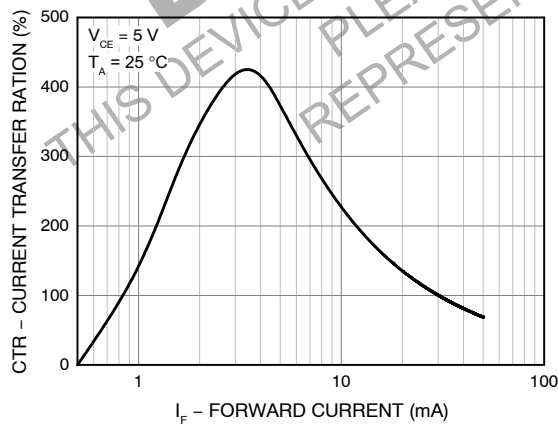


Figure 5. Current Transfer Ratio vs. Forward Current

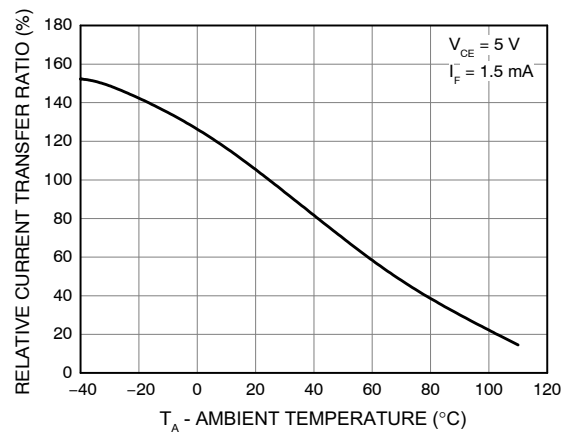
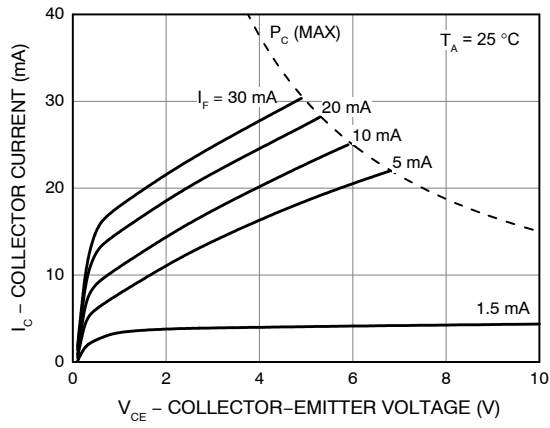
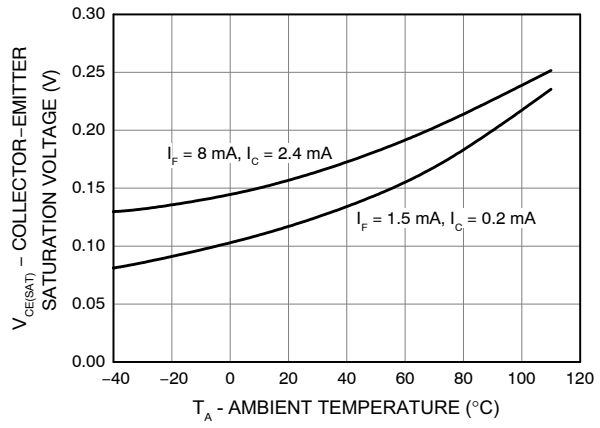


Figure 6. Relative Current Transfer Ratio vs. Ambient Temperature

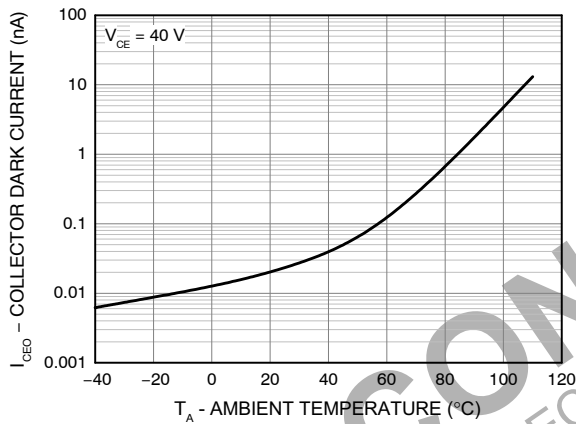
# FOD819 Series



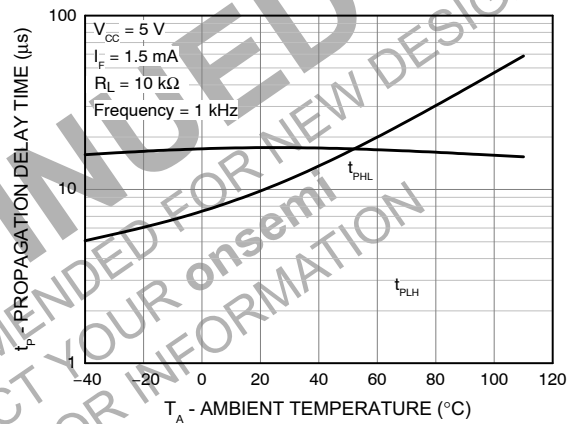
**Figure 7. Collector Current vs. Collector-Emitter Voltage**



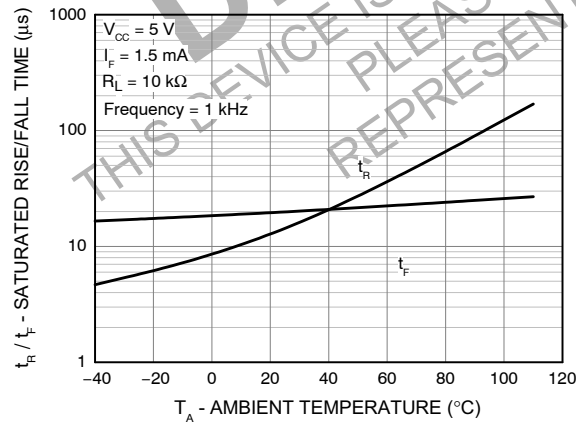
**Figure 8. Collector-Emitter Saturation Voltage vs. Ambient Temperature**



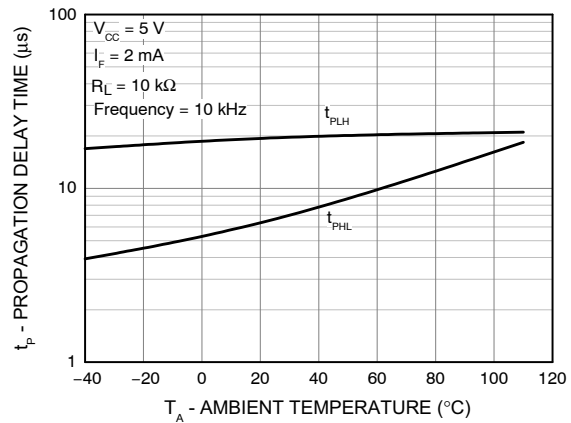
**Figure 9. Collector Dark Current vs. Ambient Temperature**



**Figure 10. Propagation Delay vs. Ambient Temperature**

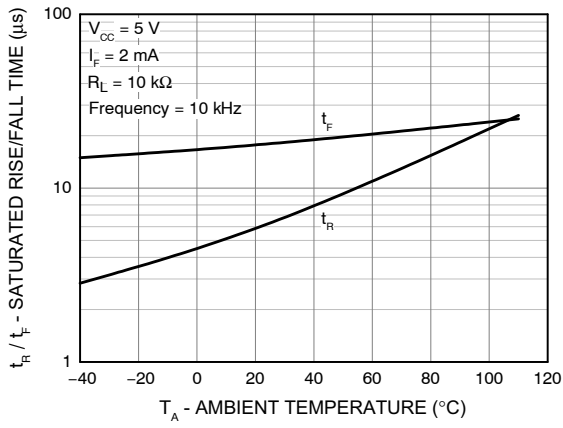


**Figure 11. Saturated Rise / Fall Time vs. Ambient Temperature**

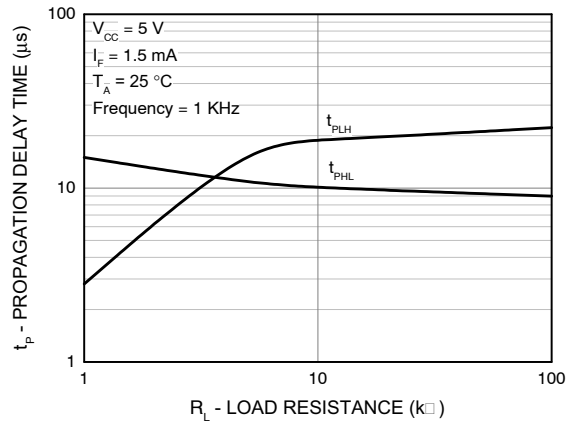


**Figure 12. Propagation Delay vs. Ambient Temperature**

# FOD819 Series

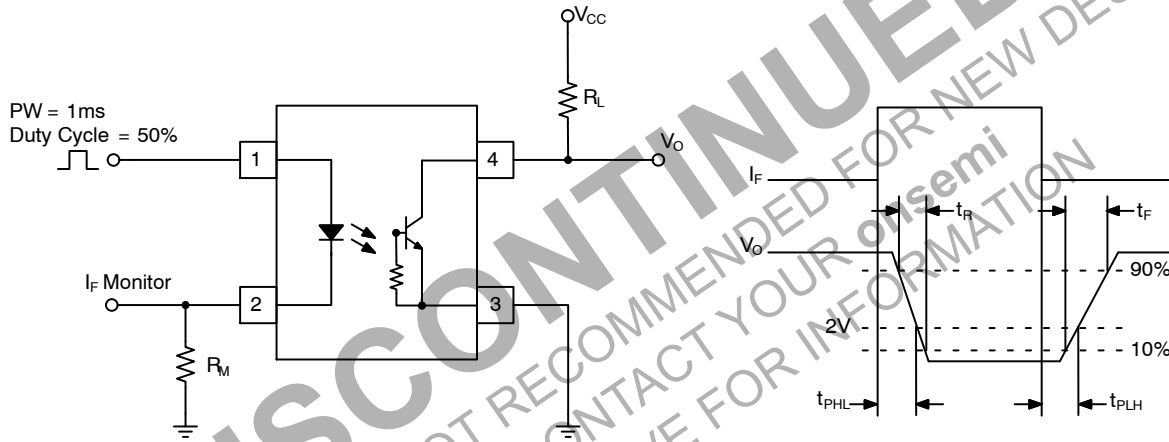


**Figure 13. Collector Dark Current vs. Ambient Temperature**



**Figure 14. Propagation Delay vs. Ambient Temperature**

## Test Circuit



**Figure 15. Test Circuit for Response Time**

**Figure 16. Timing Diagram**

# FOD819 Series

## Reflow Profile

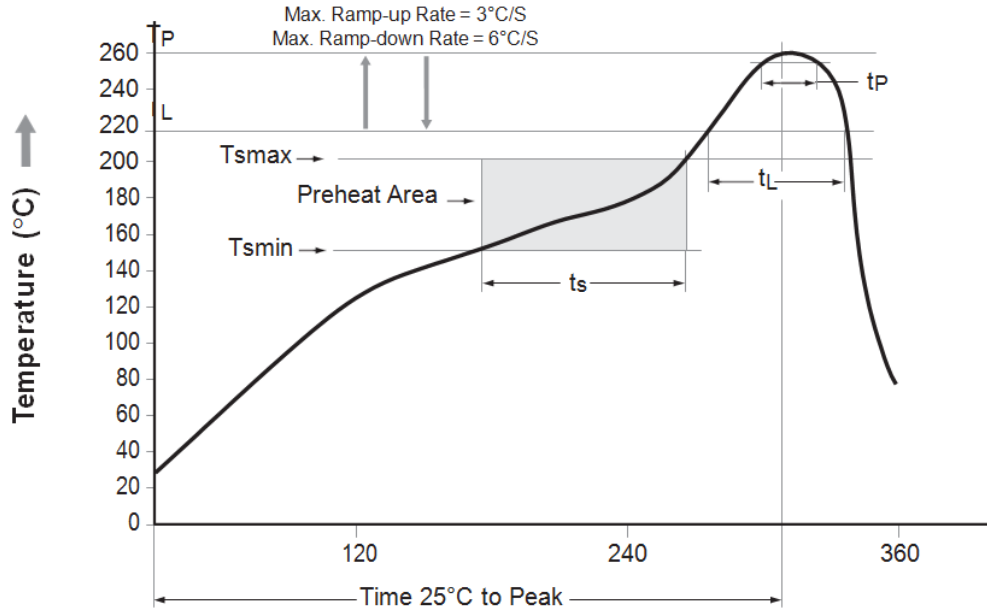


Figure 17. Reflow Profile

Table 6.

Profile Feature	Pb-Free Assembly Profile
Temperature Min. ( $T_{smin}$ )	150°C
Temperature Max. ( $T_{smax}$ )	200°C
Time ( $t_s$ ) from ( $T_{smin}$ to $T_{smax}$ )	60–120 seconds
Ramp-up Rate ( $t_L$ to $t_p$ )	3°C/second max.
Liquidous Temperature ( $T_L$ )	217°C
Time ( $t_L$ ) Maintained Above ( $T_L$ )	60–150 seconds
Peak Body Package Temperature	260°C +0°C / -5°C
Time ( $t_p$ ) within 5°C of 260°C	30 seconds
Ramp-down Rate ( $T_p$ to $T_L$ )	6°C / second max.
Time 25°C to Peak Temperature	8 minutes max.

Table 7. ORDERING INFORMATION

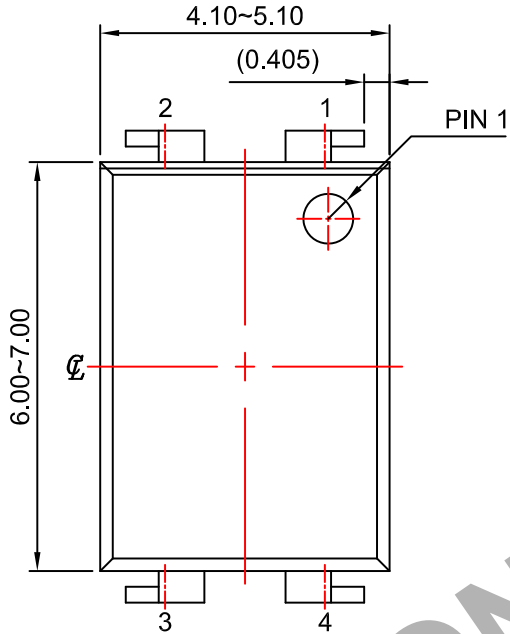
Part Number	Package	Packing Method †
FOD819	DIP 4-Pin	Tube (100 units per tube)
FOD819S	SMT 4-Pin (Lead Bend)	Tube (100 units per tube)
FOD819SD	SMT 4-Pin (Lead Bend)	Tape and Reel (1,000 units per reel)
FOD819300	DIP 4-Pin, DIN EN/IEC60747-5-5 option	Tube (100 units per tube)
FOD8193S	SMT 4-Pin (Lead Bend), DIN EN/IEC60747-5-5 option	Tube (100 units per tube)
FOD8193SD	SMT 4-Pin (Lead Bend), DIN EN/IEC60747-5-5 option	Tape and Reel (1,000 units per reel)
FOD819300W	DIP 4-Pin, 0.4" Lead Spacing, DIN EN/IEC60747-5-5 option	Tube (100 units per tube)

†For information on tape and reel specifications, including part orientation and tape sizes, please refer to our Tape and Reel Packaging Specification Brochure, BRD8011/D.

# FOD819 Series

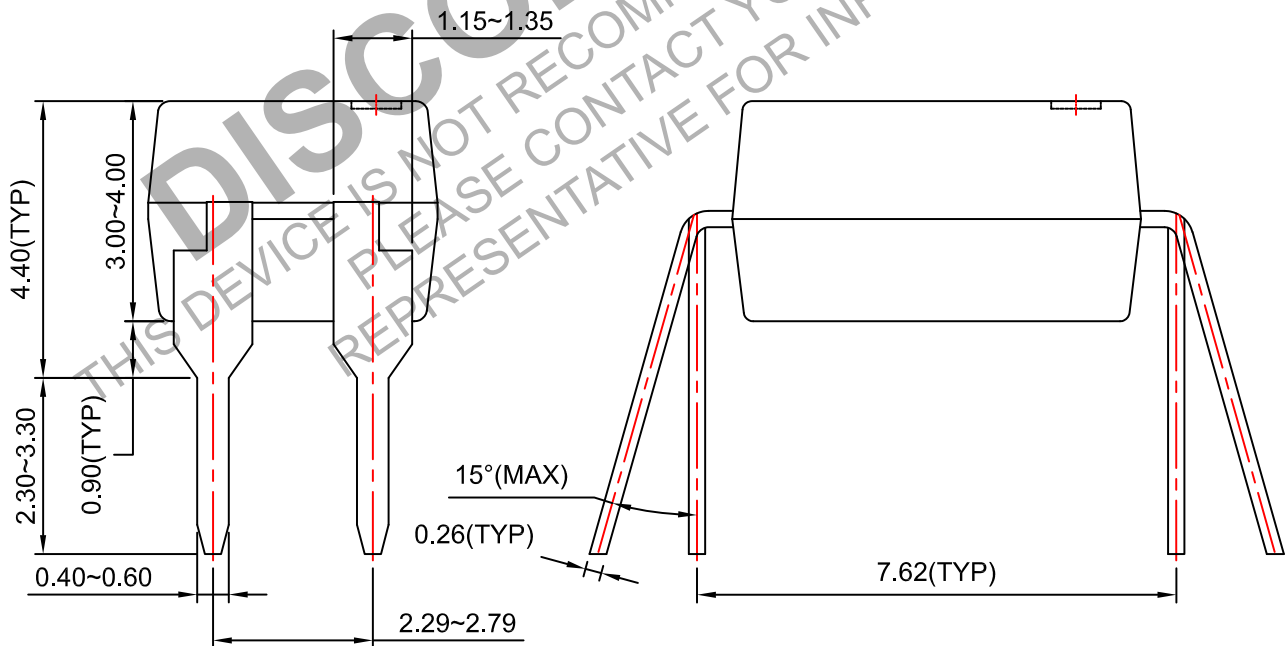
## PACKAGE DIMENSIONS

PDIP4 4.6 x 6.5, 2.54P  
CASE 646CD  
ISSUE O



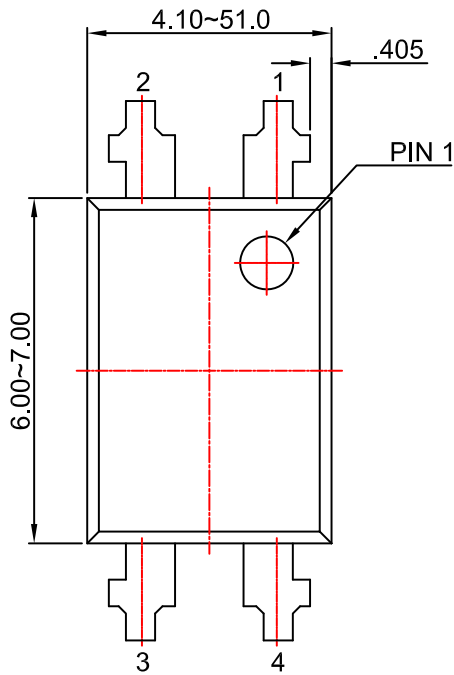
### NOTES:

- A) NO STANDARD APPLIES TO THIS PACKAGE.
- B) ALL DIMENSIONS ARE IN MILLIMETERS.
- C) DIMENSIONS ARE EXCLUSIVE OF BURRS, MOLD FLASH, AND TIE BAR EXTRUSION



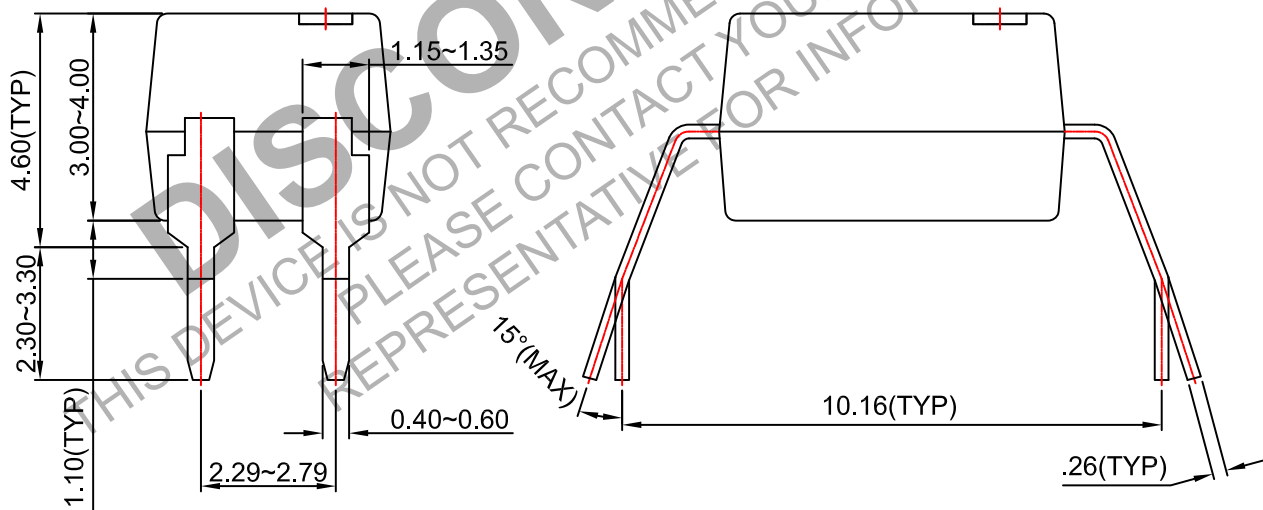
# FOD819 Series

PDIP4 4.6 x 6.5, 2.54P  
CASE 646CA  
ISSUE O



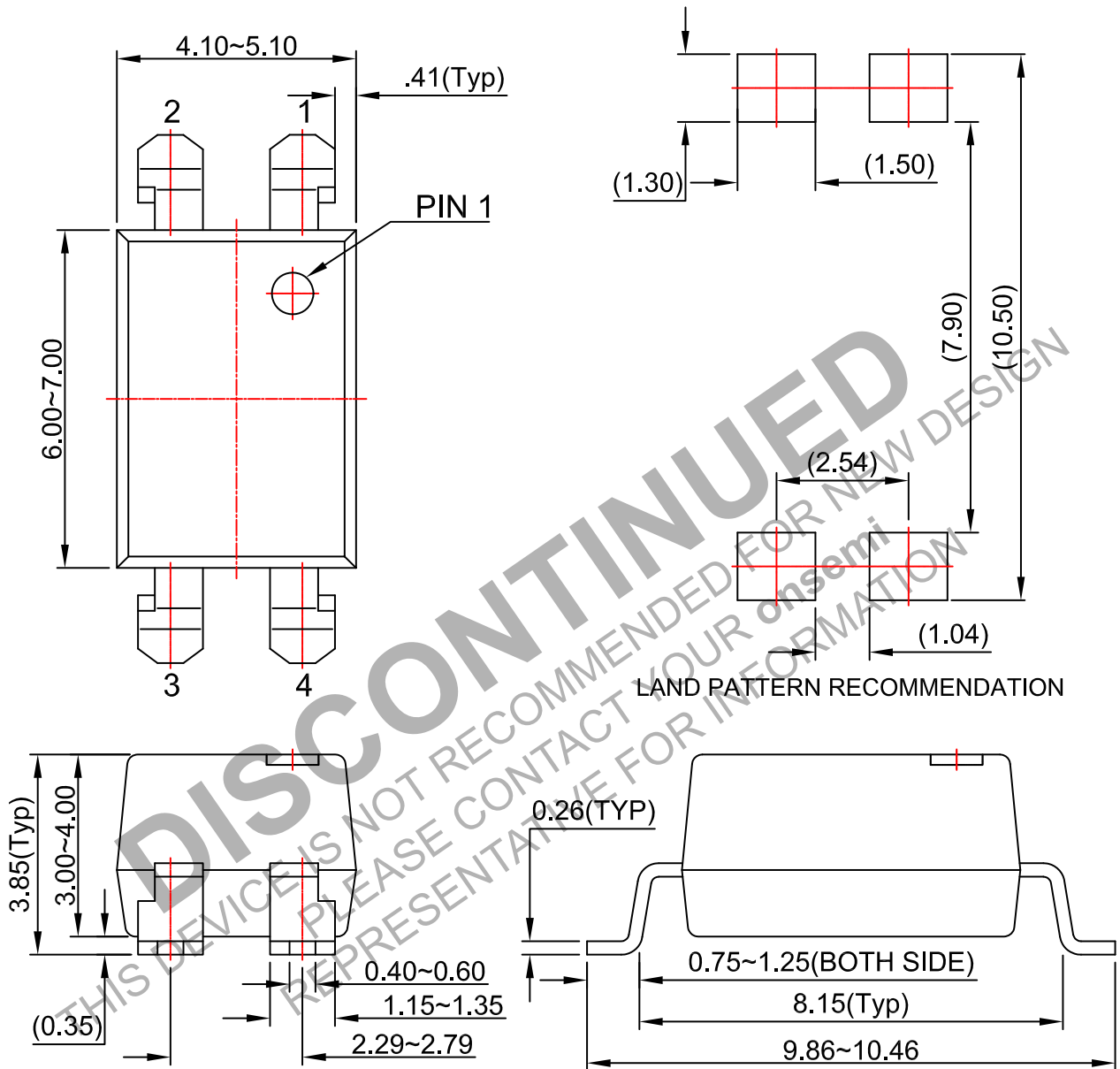
## NOTES:

- A) NO STANDARD APPLIES TO THIS PACKAGE.
- B) ALL DIMENSIONS ARE IN MILLIMETERS.
- C) DIMENSIONS ARE EXCLUSIVE OF BURRS, MOLD FLASH, AND TIE BAR EXTRUSION



# FOD819 Series


PDIP4 GW  
CASE 709AH  
ISSUE A



## NOTES:

- A) NO STANDARD APPLIES TO THIS PACKAGE.
- B) ALL DIMENSIONS ARE IN MILLIMETERS.
- C) DIMENSIONS ARE EXCLUSIVE OF BURRS, MOLD FLASH, AND TIE BAR EXTRUSION

**DISCONTINUED**  
THIS DEVICE IS NOT RECOMMENDED FOR NEW DESIGN  
PLEASE CONTACT YOUR onsemi  
REPRESENTATIVE FOR INFORMATION

ON Semiconductor and  are trademarks of Semiconductor Components Industries, LLC dba ON Semiconductor or its subsidiaries in the United States and/or other countries. ON Semiconductor owns the rights to a number of patents, trademarks, copyrights, trade secrets, and other intellectual property. A listing of ON Semiconductor's product/patent coverage may be accessed at [www.onsemi.com/site/pdf/Patent-Marking.pdf](http://www.onsemi.com/site/pdf/Patent-Marking.pdf). ON Semiconductor reserves the right to make changes without further notice to any products herein. ON Semiconductor makes no warranty, representation or guarantee regarding the suitability of its products for any particular purpose, nor does ON Semiconductor assume any liability arising out of the application or use of any product or circuit, and specifically disclaims any and all liability, including without limitation special, consequential or incidental damages. Buyer is responsible for its products and applications using ON Semiconductor products, including compliance with all laws, regulations and safety requirements or standards, regardless of any support or applications information provided by ON Semiconductor. "Typical" parameters which may be provided in ON Semiconductor data sheets and/or specifications can and do vary in different applications and actual performance may vary over time. All operating parameters, including "Typicals" must be validated for each customer application by customer's technical experts. ON Semiconductor does not convey any license under its patent rights nor the rights of others. ON Semiconductor products are not designed, intended, or authorized for use as a critical component in life support systems or any FDA Class 3 medical devices or medical devices with a same or similar classification in a foreign jurisdiction or any devices intended for implantation in the human body. Should Buyer purchase or use ON Semiconductor products for any such unintended or unauthorized application, Buyer shall indemnify and hold ON Semiconductor and its officers, employees, subsidiaries, affiliates, and distributors harmless against all claims, costs, damages, and expenses, and reasonable attorney fees arising out of, directly or indirectly, any claim of personal injury or death associated with such unintended or unauthorized use, even if such claim alleges that ON Semiconductor was negligent regarding the design or manufacture of the part. ON Semiconductor is an Equal Opportunity/Affirmative Action Employer. This literature is subject to all applicable copyright laws and is not for resale in any manner.

**PUBLICATION ORDERING INFORMATION**

**LITERATURE FULFILLMENT:**

Literature Distribution Center for ON Semiconductor  
19521 E. 32nd Pkwy, Aurora, Colorado 80011 USA  
**Phone:** 303-675-2175 or 800-344-3860 Toll Free USA/Canada  
**Fax:** 303-675-2176 or 800-344-3867 Toll Free USA/Canada  
**Email:** [orderlit@onsemi.com](mailto:orderlit@onsemi.com)



**N. American Technical Support:** 800-282-9855 Toll Free  
USA/Canada  
**Europe, Middle East and Africa Technical Support:**  
Phone: 421 33 790 2910

**ON Semiconductor Website:** [www.onsemi.com](http://www.onsemi.com)  
**Order Literature:** <http://www.onsemi.com/orderlit>

For additional information, please contact your local Sales Representative

## Looking for pricing, stock, or lifecycle information?

Click below to explore more details on WIN SOURCE:

-  [View FOD819S on WIN SOURCE](#)
-  [ON Semiconductor Information](#)

## Optimize Your Supply Chain with WIN SOURCE Solutions

-  Global Sourcing Solution
-  Obsolete Management
-  Cost Control Management
-  Shortage Management
-  Alternative Solution
-  Excess Inventory Management