

DRV600EVM User's Guide

This user's guide describes the operation and configuration of the evaluation module (EVM) for the DRV600 stereo line driver. The document also provides measurement data and design information, including a schematic, bill of materials, and layout figures.

Contents

1	Overview	2
2	Quick Setup Guide.....	4
3	Shutdown	5
4	DRV600EVM Performance	6
5	Related Documentation from Texas Instruments	11
6	Design Documentation	12

List of Figures

1	DRV600EVM	2
2	DRV600 Functional Block Diagram	3
3	DRV600EVM Physical Structure.....	4
4	Recommended Power-Up/-Down Sequence.....	5
5	THD+N vs Voltage (600Ω load).....	7
6	THD+N vs Voltage (100kΩ load)	7
7	THD+N vs Frequency (600Ω load)	7
8	THD+N vs Frequency (600Ω load) Using X7R Input Caps	8
9	FFT Spectrum with –60dBFS Tone	8
10	Idle Noise FFT Spectrum	9
11	Channel Separation	9
12	Frequency Response	10
13	Phase Response	10
14	Pop/Click (Enable)	11
15	Pop/Click (Disable).....	11
16	DRV600EVM Schematic	12
17	DRV600EVM PCB Component Side (Top)	14
18	PCB Top Layer	14
19	PCB Bottom Layer	14

List of Tables

1	DRV600 Features.....	2
2	Recommended Supply Voltage	5
3	General Test Specifications	6
4	Electrical Data	6
5	Audio Performance Data.....	6
6	Physical Specifications.....	6
7	Related Documentation from Texas Instruments	11
8	DRV600EVM Parts List.....	13
9	PCB Specifications.....	13

1 Overview

The DRV600EVM evaluation module demonstrates the capabilities and performance of the [DRV600RTJ](#) from Texas Instruments.

The DRV600 is a stereo line driver designed to allow the removal of the dc-blocking capacitors typically found in an audio application, reducing overall component count and cost. The DRV600 is ideal for single-supply electronics where size and cost are critical design parameters.

The DRV600 is capable of driving $2V_{RMS}$ into a 600Ω load with a 3.3V supply. The DRV600 has a fixed gain of $-1.5V/V$ and line outputs that have $\pm 8kV$ electrostatic discharge (ESD) protection. The DRV600 also has independent shutdown controls for the left and right audio channels.

This EVM is configured with two RCA phone input connectors and two RCA phone output connectors. The power supply is connected via a 2-pin, 2.54mm pin header. [Table 1](#) summarizes the key parameters of the device.

Table 1. DRV600 Features

KEY PARAMETERS	
Supply Voltage	1.8V to 4.5V
Number of Channels	2
Load Impedance	Min 600Ω
Output Voltage	$2V_{RMS} / 600\Omega < 0.1\%$ THD
DYR	$> 108dB$

This EVM is designed for evaluating applications such as A/V receivers, DVD receivers, DVD mini-component systems, home theater in a box (HTIB) designs, or set-top boxes. The module is designed to quickly demonstrate the electrical performance of the device.

This document covers EVM specifications and audio performance measurement graphs. It provides design documentation including schematics, a parts list, layout, and mechanical design.

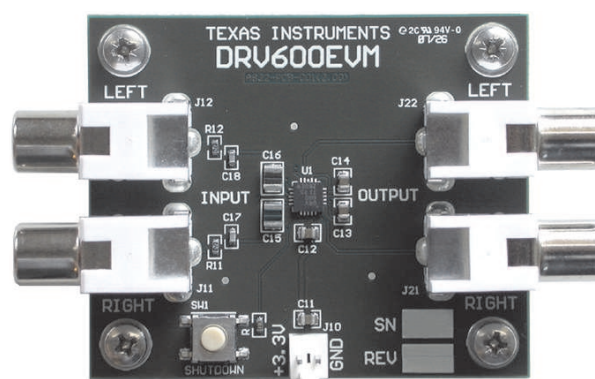

Figure 1. DRV600EVM

Gerber files are available for download through the [DRV600RTJ product folder](#) on the [TI web site](#).

The EVM is delivered with cables and an input-USB board to connect to an input source. The evaluation board can be controlled by a PC.

Throughout this document, the acronym *EVM* and the phrases *evaluation module* and *evaluation board* are synonymous with the DRV600EVM.

1.1 DRV600EVM Features

- Two-channel evaluation module, a double-sided, plated-through printed circuit board (PCB)
- $2V_{RMS}$ line output
- No output capacitors
- Shutdown button

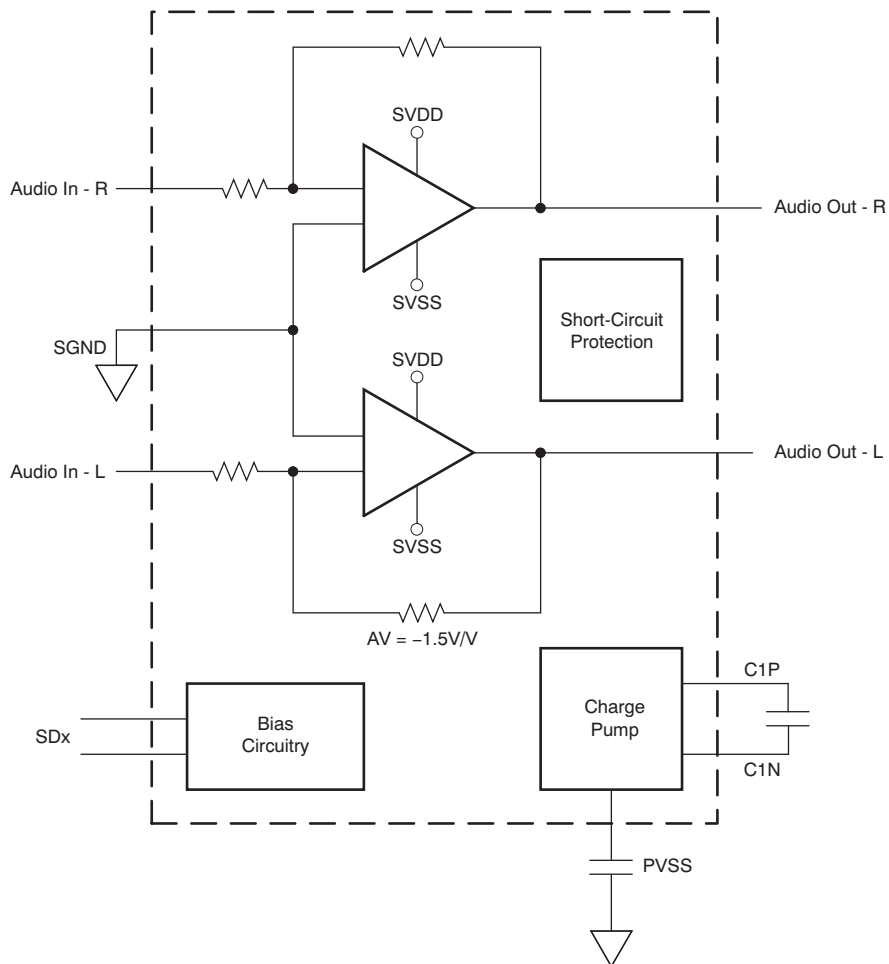

Figure 2. DRV600 Functional Block Diagram

1.2 PCB Key Map

The physical structure of the DRV600EVM is shown in [Figure 3](#).

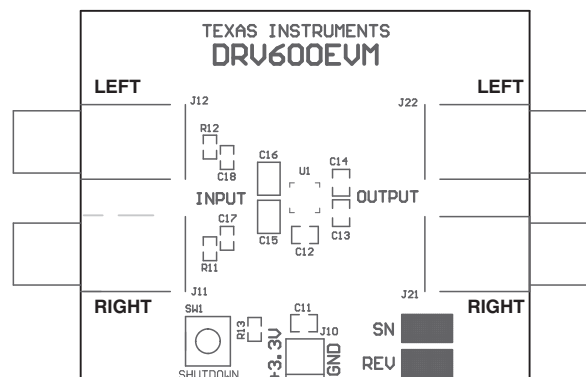

Figure 3. DRV600EVM Physical Structure

2 Quick Setup Guide

This section describes the DRV600EVM with regard to power supply and the system interface. It also provides information about handling and unpacking the module, absolute operating conditions, and a description of the factory default switch and jumper configuration.

2.1 Electrostatic Discharge Warning

Many of the components on the DRV600EVM are susceptible to damage by electrostatic discharge (ESD). Customers are advised to observe proper ESD handling precautions when unpacking and handling the EVM, including the use of a grounded wrist strap at an approved ESD workstation.

CAUTION

Failure to observe ESD handling procedures may result in damage to EVM components.

2.2 Unpacking the EVM

Upon opening the DRV600EVM package, please check to make sure that the following items are included:

- 1 DRV600EVM board with one DRV600RTJ device installed
- 1 PurePath CD-ROM

If either of these items is missing, please contact the Texas Instruments Product Information Center nearest you to inquire about a replacement.

2.3 Power Supply Setup

To power up the EVM, one power supply is needed. The power supply is connected to the EVM using a 2-pin, 2.54mm pin header, J10. [Table 2](#) summarizes the EVM power-supply requirements.

Table 2. Recommended Supply Voltage

DESCRIPTION	VOLTAGE LIMITATIONS	CURRENT REQUIREMENT	CABLE
Power supply	1.8V to 4.5V	0.3A	

CAUTION

Failure to observe ESD handling procedures may result in damage to EVM components.

3 Shutdown

For minimum click and pop interference during power-up and power-down, the shutdown pin should be kept low. The preferred power-up/-down sequence is shown in [Figure 4](#).

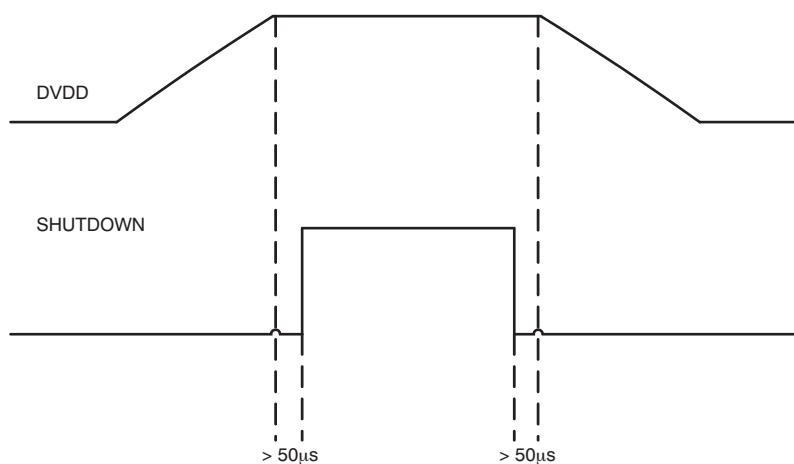

Figure 4. Recommended Power-Up/-Down Sequence

4 DRV600EVM Performance

This section provides the general test specifications, the electrical data, audio performance data, and physical specifications.

Table 3. General Test Specifications⁽¹⁾

GENERAL TEST SPECIFICATIONS		NOTES/CONDITIONS
Supply Voltage	3.3V	
Load Impedance	600Ω	
Input Signal	1kHz Sine	
Measurement Filter	AES17	

⁽¹⁾ These test conditions are used for all tests, unless otherwise specified.

Table 4. Electrical Data⁽¹⁾

ELECTRICAL DATA SPECIFICATIONS		NOTES/CONDITIONS
Output Voltage, 600Ω	2.1V _{RMS}	1kHz, unclipped (< 1% THD), T _A = +25°C
Output Voltage, 600Ω	V _{RMS}	1kHz, 10% THD+N, T _A = +25°C
Output Voltage, 100kΩ	2.15V _{RMS}	1kHz, unclipped (< 1% THD), T _A = +25°C
Output Voltage, 100kΩ	V _{RMS}	1kHz, 10% THD+N, T _A = +25°C
Supply Current	< 10mA	1kHz, 2mV _{RMS} output voltage
Supply Current	< 12mA	1kHz, 2V _{RMS} output voltage

⁽¹⁾ All electrical and audio specifications are typical values.

Table 5. Audio Performance Data⁽¹⁾

AUDIO PERFORMANCE SPECIFICATIONS			NOTES/CONDITIONS
THD+N, 600Ω	0.02V _{RMS}	< 0.02 %	1kHz
THD+N, 600Ω	0.2V _{RMS}	< 0.05 %	1kHz
THD+N, 600Ω	2V _{RMS}	< 0.08 %	1kHz
THD+N, 100kΩ	0.02V _{RMS}	< 0.10 %	1kHz
THD+N, 100kΩ	0.2V _{RMS}	< 0.13 %	1kHz
THD+N, 100kΩ	2V _{RMS}	< 0.02 %	1kHz
Dynamic Range		> 109dB	Ref: 2V _{RMS} , A-weighted, AES17 filter
Noise Voltage		< 7μV _{RMS}	A-weighted, AES17 filter
DC Offset		< 5mV	No signal, 600Ω load
Channel Separation		> 90dB	1kHz, 2V _{RMS}
Frequency Response: 20Hz to 20kHz		+0.5/-0.5dB	2V _{RMS} /600Ω

⁽¹⁾ All electrical and audio specifications are typical values.

Table 6. Physical Specifications

PHYSICAL SPECIFICATIONS		NOTES/CONDITIONS
PCB Dimensions	50 x 60 x 25	Width x Length x Height (mm)
Total Weight	35g	Components + PCB + Mechanics

4.1 THD+N vs Voltage (600Ω load)

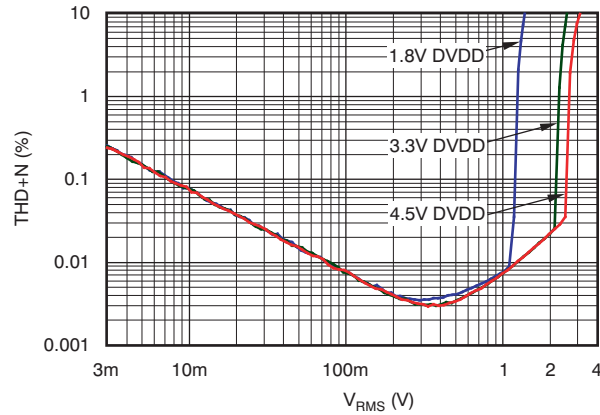

Figure 5. THD+N vs Voltage (600Ω load)

4.2 THD+N vs Voltage (100kΩ load)

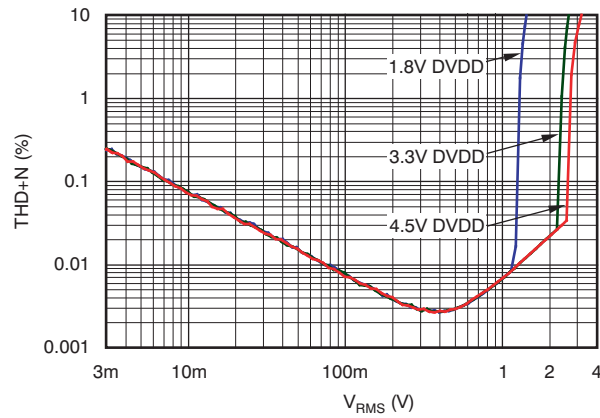

Figure 6. THD+N vs Voltage (100kΩ load)

4.3 THD+N vs Frequency (600Ω load)

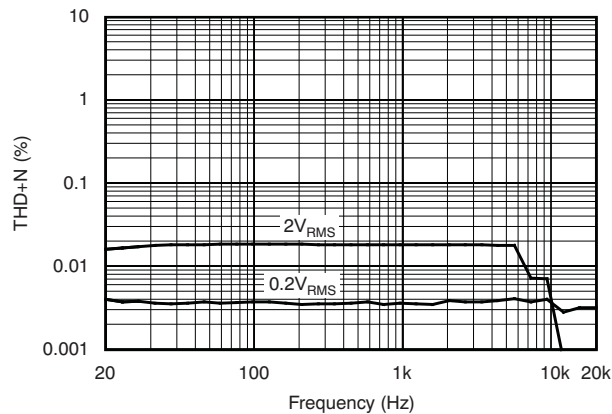

Figure 7. THD+N vs Frequency (600Ω load)

The DRV600EVM uses a 1 μ F film capacitor for ac-coupling of the input signal. If a lower cost ceramic capacitor such as an X7R is used, higher THD at low frequencies should be expected. Y5V capacitors will show even higher THD performance and should not be used.

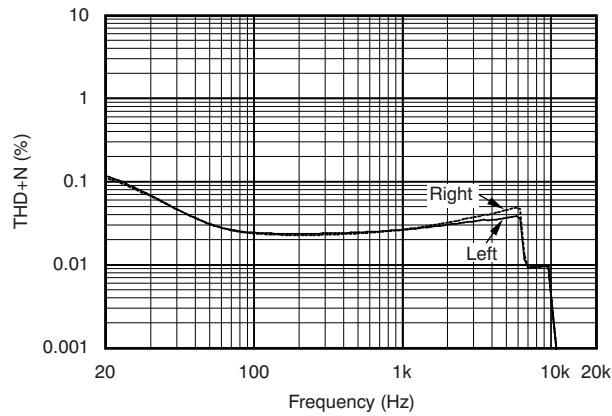

Figure 8. THD+N vs Frequency (600 Ω load) Using X7R Input Caps

The X7R capacitors raises the 20Hz THD from 0.02% to 0.1%—five times higher.

4.3.1 FFT Spectrum with -60dBFS Tone

Reference voltage is 2V_{RMS}, FFT size 16k.

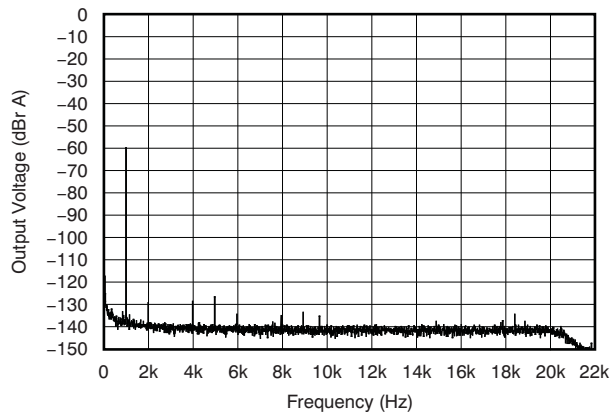

Figure 9. FFT Spectrum with -60dBFS Tone

This spectrum corresponds to a dynamic range of 110dB, A-weighted. SNR measures at 110dB, A-weighted.

4.4 Idle Noise FFT Spectrum

Reference voltage is $2V_{RMS}$, FFT size 16k.

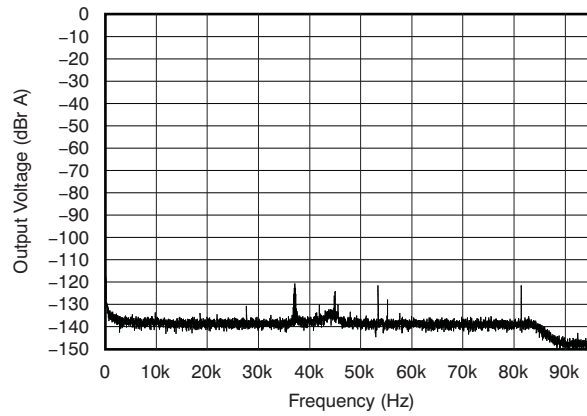

Figure 10. Idle Noise FFT Spectrum

4.5 Channel Separation

Channel 1 output signal is $2V_{RMS}$; channel 2 input is grounded. Reference voltage is $2V_{RMS}$; the load is 600Ω .

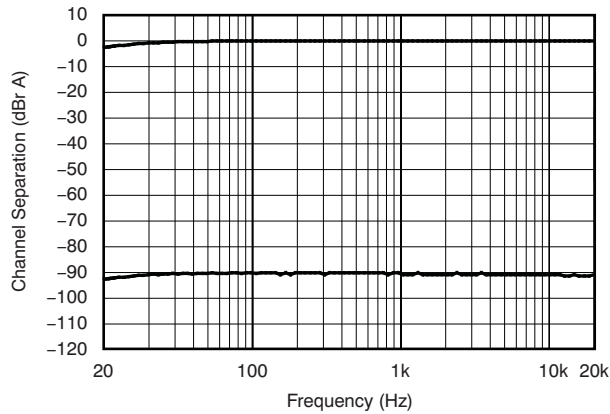

Figure 11. Channel Separation

4.6 Frequency Response

Measurement bandwidth filter is set to 500kHz.

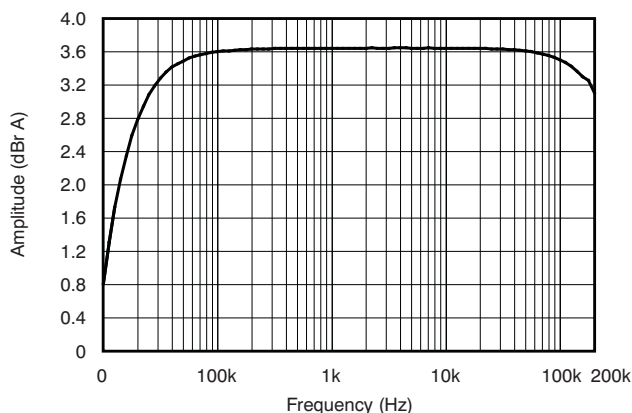

Figure 12. Frequency Response

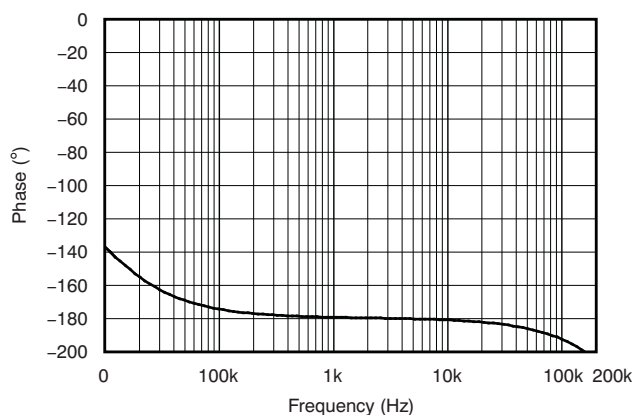

Figure 13. Phase Response

The low frequency cutoff of 10Hz (-3dB) is determined by the input ac-coupling capacitor together with the input impedance of the DRV600.

A $1\mu\text{F}$ capacitor is used on the DRV600EVM. The input impedance of the DRV600 is $15\text{k}\Omega$. This impedance gives a -3dB cutoff of 10Hz. This result corresponds with the frequency response measurements above.

An RC filter is placed at the DRV600 to filter high-frequency noise. A 220Ω resistor and a 1nF NPO capacitor is used. This configuration gives a -3dB frequency of 720kHz.

4.7 Pop/Click (Enable)

No input signal is applied. The measurement results are presented both in a time domain and in a frequency domain. The resistor load is 600Ω in both examples.

The power supply is applied, and then the shutdown signal is released. The shutdown signal is used to trigger the measuring system.

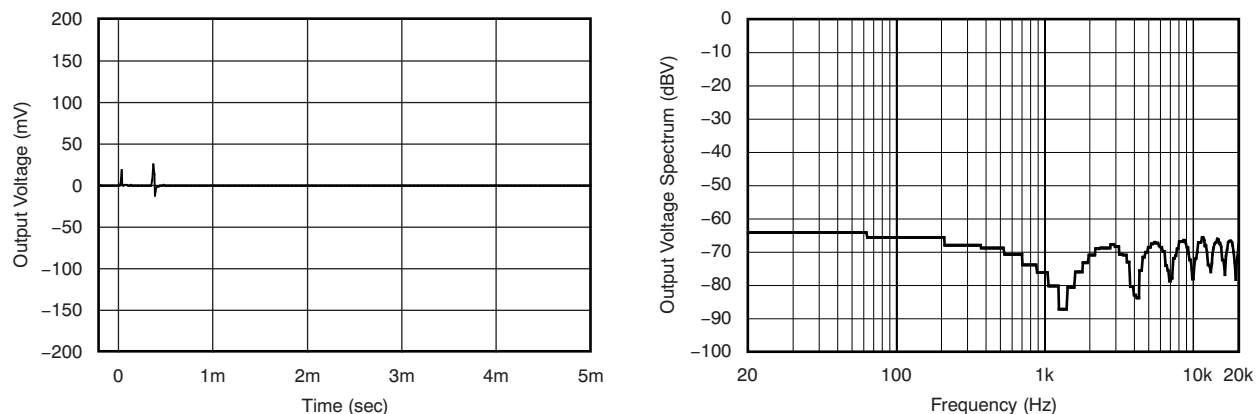

Figure 14. Pop/Click (Enable)

The DRV600 shows very low pop interference during the enable time; only two small, high-frequency spikes can be seen.

4.8 Pop/Click (Disable)

No input signal is applied. The measurement results are presented both in a time domain and in a frequency domain.

The resistive load is 600Ω in both examples.

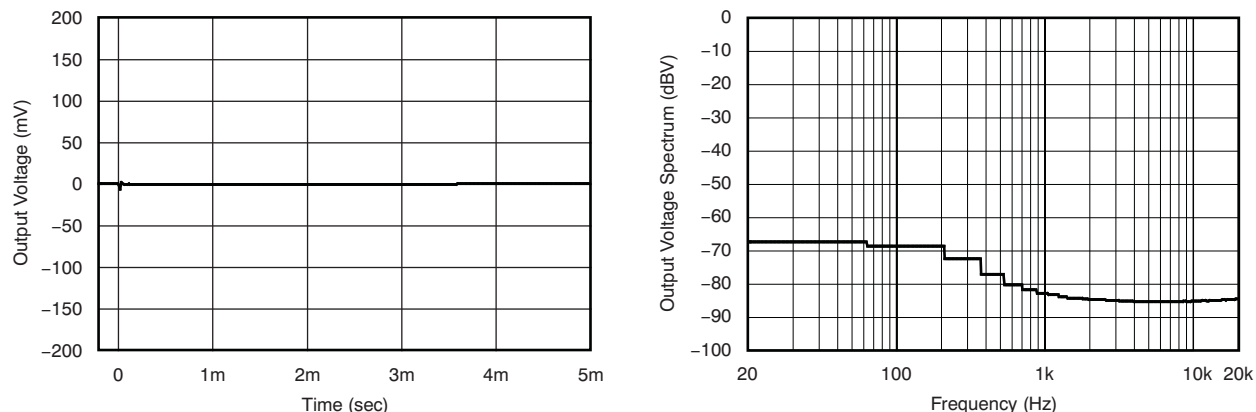

Figure 15. Pop/Click (Disable)

During power-down, the click is even lower than during power-on (enable). A very small click is seen.

5 Related Documentation from Texas Instruments

Table 7 contains a list of documents that have a detailed description of the integrated circuits used in the design of the DRV600EVM. The data sheet can be obtained through [the TI website](#).

Table 7. Related Documentation from Texas Instruments

PART NUMBER	LITERATURE NUMBER
DRV600	SLOS536

6 Design Documentation

This section includes a schematic for the DRV600EVM as well as the bill of materials (BOM) and the PCB design specifications.

6.1 Schematic

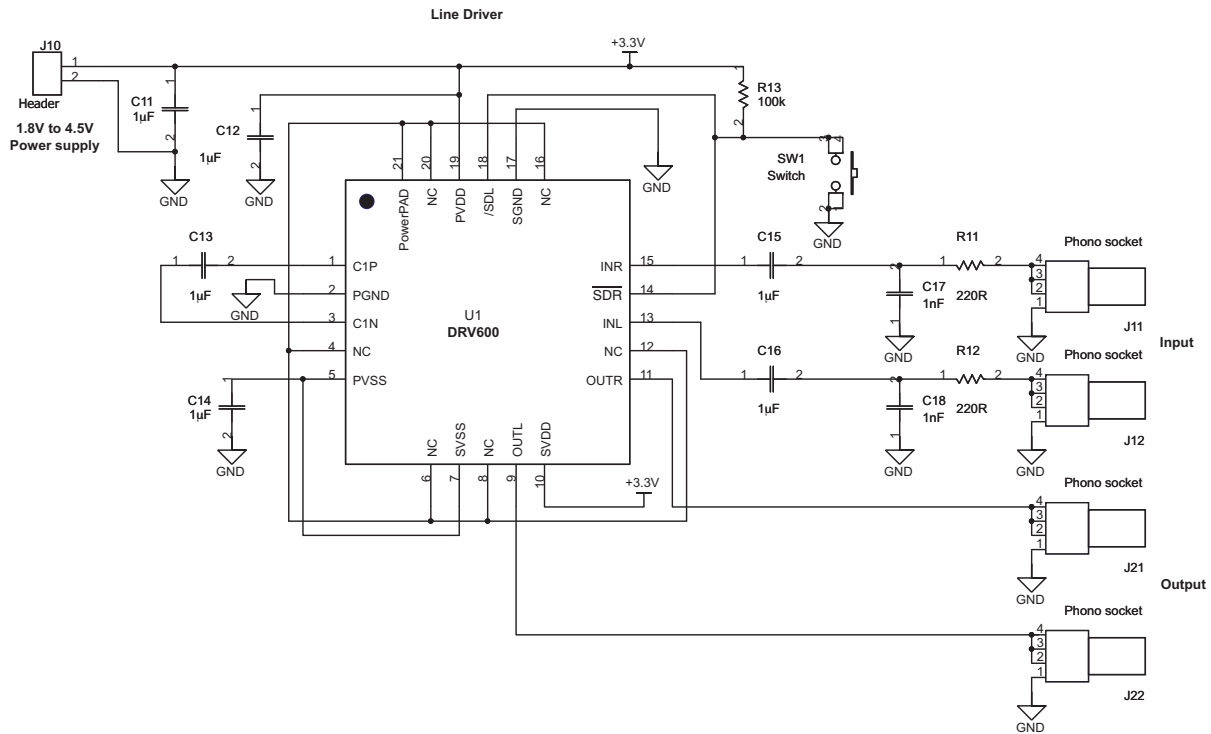

Figure 16. DRV600EVM Schematic

6.2 Parts List

Table 8. DRV600EVM Parts List

QTY	REFERENCE DESIGNATOR	DESCRIPTION	MANUFACTURER	MFR PART NO.
1	R13	100k / 100mW / 5% / 0603 Thick Film Resistor	Yageo	RC0603JR-07100KL
2	R11 R12	220R / 100mW / 5% / 0603 Thick Film Resistor	Yageo	RC0603JR-07220RL
4	C11 C12 C13 C14	Ceramic 1uF / 16V / 20% X7R 0805 Capacitor	BC Components	0805B105M160NT
2	C17 C18	Ceramic 1nF / 50V / 10% NP0 0603 Capacitor	BC Components	0603N102K500NT
2	C15 C16	Metal Film 1uF / 16V / 20% Polyester 1210 Capacitor	Panasonic	EPCU1C105MA5
1	U1	DRV600 / DirectPath(TM) Audio Line Driver (QFN-20)	Texas Instruments	DRV600
1	J10	2 pins / 1 row / 2.54mm Pitch Vertical Male Friction lock Pin header Header	Molex	22-27-2021
4	J11 J12 J21 J22	Horizontal Female w. Switch Coax Phono socket	Chunfeng	RJ843-4W
1	SW1	Switch 6mm SMD Tactile Switch Switch	Omron	B3S-1000
1	PCB11	A832-PCB-001_2.00 / DRV600EVM Printed Circuit Board (ver. 2.00)	Printline	A832-PCB-001(2.00)

6.3 PCB Specifications

Table 9. PCB Specifications

BOARD IDENTIFICATION	A832-PCB-001(2.00)
BOARD TYPE	Double-sided plated-through board
LAMINATE TYPE	FR4
LAMINATE THICKNESS	1.6mm
COPPER THICKNESS	35µm (Include plating exterior layer)
COPPER PLATING OF HOLES	> 25µm
MINIMUM HOLE DIAMETER	0.3mm
SILKSCREEN COMPONENT SIDE	White—Remove silkscreen from solder area and pre-tinned areas
SILKSCREEN SOLDER SIDE	None
SOLDER MASK COMPONENT SIDE	Green
SOLDER MASK SOLDER SIDE	Green
PROTECTIVE COATING	Solder coating and chemical silver on free copper
ELECTRICAL TEST	PCB must be electrically tested
MANUFACTURED TO	PERFAG 2E (www.perfag.dk)
APERTURE TABLE	PERFAG 10A (www.perfag.dk)
BOARD SIZE	60mm × 50mm
COMMENTS	See drill information file (A832-PCB-001 (DrillDrawing).pdf) in the gerber file zip, available in the EVM tool folder .

6.4 PCB Layout

Figure 17 through Figure 19 show the printed circuit board (PCB) schematics. The Gerber files are available for download through the DRV600EVM tool folder on www.ti.com.

Note: Board layouts are not to scale. These figures are intended to show how the board is laid out; they are not intended to be used for manufacturing DRV600EVM PCBs.

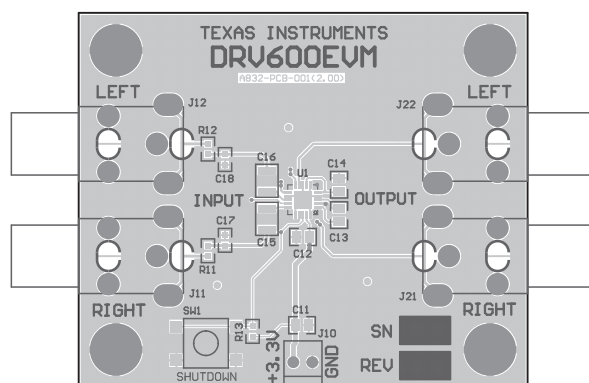

Figure 17. DRV600EVM PCB Component Side (Top)

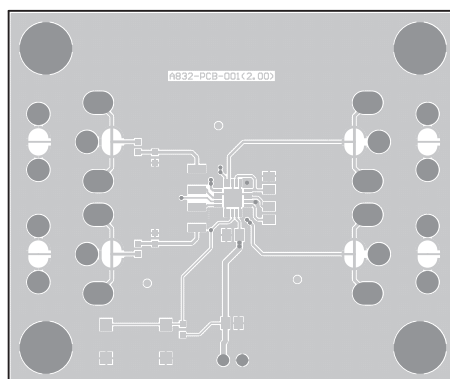

Figure 18. PCB Top Layer

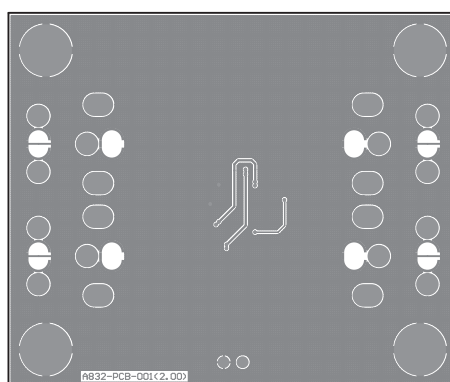

Figure 19. PCB Bottom Layer

EVALUATION BOARD/KIT IMPORTANT NOTICE

Texas Instruments (TI) provides the enclosed product(s) under the following conditions:

This evaluation board/kit is intended for use for **ENGINEERING DEVELOPMENT, DEMONSTRATION, OR EVALUATION PURPOSES ONLY** and is not considered by TI to be a finished end-product fit for general consumer use. Persons handling the product(s) must have electronics training and observe good engineering practice standards. As such, the goods being provided are not intended to be complete in terms of required design-, marketing-, and/or manufacturing-related protective considerations, including product safety and environmental measures typically found in end products that incorporate such semiconductor components or circuit boards. This evaluation board/kit does not fall within the scope of the European Union directives regarding electromagnetic compatibility, restricted substances (RoHS), recycling (WEEE), FCC, CE or UL, and therefore may not meet the technical requirements of these directives or other related directives.

Should this evaluation board/kit not meet the specifications indicated in the User's Guide, the board/kit may be returned within 30 days from the date of delivery for a full refund. **THE FOREGOING WARRANTY IS THE EXCLUSIVE WARRANTY MADE BY SELLER TO BUYER AND IS IN LIEU OF ALL OTHER WARRANTIES, EXPRESSED, IMPLIED, OR STATUTORY, INCLUDING ANY WARRANTY OF MERCHANTABILITY OR FITNESS FOR ANY PARTICULAR PURPOSE.**

The user assumes all responsibility and liability for proper and safe handling of the goods. Further, the user indemnifies TI from all claims arising from the handling or use of the goods. Due to the open construction of the product, it is the user's responsibility to take any and all appropriate precautions with regard to electrostatic discharge.

EXCEPT TO THE EXTENT OF THE INDEMNITY SET FORTH ABOVE, NEITHER PARTY SHALL BE LIABLE TO THE OTHER FOR ANY INDIRECT, SPECIAL, INCIDENTAL, OR CONSEQUENTIAL DAMAGES.

TI currently deals with a variety of customers for products, and therefore our arrangement with the user **is not exclusive.**

TI assumes **no liability for applications assistance, customer product design, software performance, or infringement of patents or services described herein.**

Please read the User's Guide and, specifically, the Warnings and Restrictions notice in the User's Guide prior to handling the product. This notice contains important safety information about temperatures and voltages. For additional information on TI's environmental and/or safety programs, please contact the TI application engineer or visit www.ti.com/esh.

No license is granted under any patent right or other intellectual property right of TI covering or relating to any machine, process, or combination in which such TI products or services might be or are used.

FCC Warning

This evaluation board/kit is intended for use for **ENGINEERING DEVELOPMENT, DEMONSTRATION, OR EVALUATION PURPOSES ONLY** and is not considered by TI to be a finished end-product fit for general consumer use. It generates, uses, and can radiate radio frequency energy and has not been tested for compliance with the limits of computing devices pursuant to part 15 of FCC rules, which are designed to provide reasonable protection against radio frequency interference. Operation of this equipment in other environments may cause interference with radio communications, in which case the user at his own expense will be required to take whatever measures may be required to correct this interference.

Mailing Address: Texas Instruments, Post Office Box 655303, Dallas, Texas 75265
Copyright © 2007, Texas Instruments Incorporated

EVM WARNINGS AND RESTRICTIONS

It is important to operate this EVM within the input voltage range of 1.8 V to 4.5 V and the output voltage range of 2 Vrms.

Exceeding the specified input range may cause unexpected operation and/or irreversible damage to the EVM. If there are questions concerning the input range, please contact a TI field representative prior to connecting the input power.

Applying loads outside of the specified output range may result in unintended operation and/or possible permanent damage to the EVM. Please consult the EVM User's Guide prior to connecting any load to the EVM output. If there is uncertainty as to the load specification, please contact a TI field representative.

During normal operation, some circuit components may have case temperatures greater than 85°C. The EVM is designed to operate properly with certain components above 85°C as long as the input and output ranges are maintained. These components include but are not limited to linear regulators, switching transistors, pass transistors, and current sense resistors. These types of devices can be identified using the EVM schematic located in the EVM User's Guide. When placing measurement probes near these devices during operation, please be aware that these devices may be very warm to the touch.

Mailing Address: Texas Instruments, Post Office Box 655303, Dallas, Texas 75265
Copyright © 2007, Texas Instruments Incorporated

IMPORTANT NOTICE

Texas Instruments Incorporated and its subsidiaries (TI) reserve the right to make corrections, modifications, enhancements, improvements, and other changes to its products and services at any time and to discontinue any product or service without notice. Customers should obtain the latest relevant information before placing orders and should verify that such information is current and complete. All products are sold subject to TI's terms and conditions of sale supplied at the time of order acknowledgment.

TI warrants performance of its hardware products to the specifications applicable at the time of sale in accordance with TI's standard warranty. Testing and other quality control techniques are used to the extent TI deems necessary to support this warranty. Except where mandated by government requirements, testing of all parameters of each product is not necessarily performed.

TI assumes no liability for applications assistance or customer product design. Customers are responsible for their products and applications using TI components. To minimize the risks associated with customer products and applications, customers should provide adequate design and operating safeguards.

TI does not warrant or represent that any license, either express or implied, is granted under any TI patent right, copyright, mask work right, or other TI intellectual property right relating to any combination, machine, or process in which TI products or services are used. Information published by TI regarding third-party products or services does not constitute a license from TI to use such products or services or a warranty or endorsement thereof. Use of such information may require a license from a third party under the patents or other intellectual property of the third party, or a license from TI under the patents or other intellectual property of TI.

Reproduction of TI information in TI data books or data sheets is permissible only if reproduction is without alteration and is accompanied by all associated warranties, conditions, limitations, and notices. Reproduction of this information with alteration is an unfair and deceptive business practice. TI is not responsible or liable for such altered documentation. Information of third parties may be subject to additional restrictions.

Resale of TI products or services with statements different from or beyond the parameters stated by TI for that product or service voids all express and any implied warranties for the associated TI product or service and is an unfair and deceptive business practice. TI is not responsible or liable for any such statements.

TI products are not authorized for use in safety-critical applications (such as life support) where a failure of the TI product would reasonably be expected to cause severe personal injury or death, unless officers of the parties have executed an agreement specifically governing such use. Buyers represent that they have all necessary expertise in the safety and regulatory ramifications of their applications, and acknowledge and agree that they are solely responsible for all legal, regulatory and safety-related requirements concerning their products and any use of TI products in such safety-critical applications, notwithstanding any applications-related information or support that may be provided by TI. Further, Buyers must fully indemnify TI and its representatives against any damages arising out of the use of TI products in such safety-critical applications.

TI products are neither designed nor intended for use in military/aerospace applications or environments unless the TI products are specifically designated by TI as military-grade or "enhanced plastic." Only products designated by TI as military-grade meet military specifications. Buyers acknowledge and agree that any such use of TI products which TI has not designated as military-grade is solely at the Buyer's risk, and that they are solely responsible for compliance with all legal and regulatory requirements in connection with such use.

TI products are neither designed nor intended for use in automotive applications or environments unless the specific TI products are designated by TI as compliant with ISO/TS 16949 requirements. Buyers acknowledge and agree that, if they use any non-designated products in automotive applications, TI will not be responsible for any failure to meet such requirements.

Following are URLs where you can obtain information on other Texas Instruments products and application solutions:

Products		Applications	
Amplifiers	amplifier.ti.com	Audio	www.ti.com/audio
Data Converters	dataconverter.ti.com	Automotive	www.ti.com/automotive
DSP	dsp.ti.com	Broadband	www.ti.com/broadband
Interface	interface.ti.com	Digital Control	www.ti.com/digitalcontrol
Logic	logic.ti.com	Military	www.ti.com/military
Power Mgmt	power.ti.com	Optical Networking	www.ti.com/opticalnetwork
Microcontrollers	microcontroller.ti.com	Security	www.ti.com/security
RFID	www.ti-rfid.com	Telephony	www.ti.com/telephony
Low Power Wireless	www.ti.com/lpw	Video & Imaging	www.ti.com/video
		Wireless	www.ti.com/wireless

Mailing Address: Texas Instruments, Post Office Box 655303, Dallas, Texas 75265
Copyright © 2007, Texas Instruments Incorporated

Looking for pricing, stock, or lifecycle information?

Click below to explore more details on WIN SOURCE:

 [View DRV600EVM](#) on WIN SOURCE

 [Texas Instruments](#) Information

Optimize Your Supply Chain with WIN SOURCE Solutions

-  Global Sourcing Solution
-  Obsolete Management
-  Cost Control Management
-  Shortage Management
-  Alternative Solution
-  Excess Inventory Management