



THE DATASHEET OF DEM-SOT23LDO



DEM-SOT23LDO DEMONSTRATION FIXTURE

This User's Guide describes the characteristics, operation, and use of the DEM-SOT23LDO demonstration module (DEM).

1 Background

This DEM is designed to help the user easily evaluate and test the operation and functionality of Texas Instruments 5 and 6 lead SOT23 (DBV) package LDOs. This User's Guide includes setup instructions, a schematic diagram, and a PCB layout drawing for the DEM.

2 Setup

This DEM is specifically designed to be assembled with surface mount devices with footprints ranging from 603 to 1210. Additional holes have also been provided to accommodate leaded components. Refer to the product data sheet for specific guidelines when selecting components. For all designs, C1 and C2 are used as the input and output capacitors. Adjustable devices in the 5 lead packages use only R1 and R2. Refer to the typical application circuits in the product data sheet when populating the components. J5 is used to provide access to pin 4 for LDOs that feature a power good (PG) pin. The specific IC to be tested may be obtained through TI's sample program. All components other than the PWB are user supplied.

Figure 1 through Figure 3 show the board layout for the DEM-SOT23LDO printed circuit board.

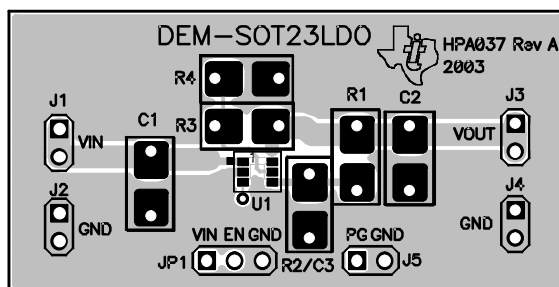

Figure 1. Assembly Layer

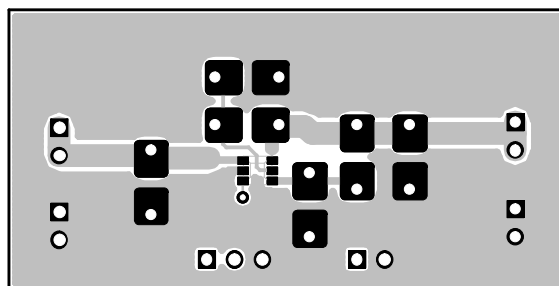

Figure 2. Top Layer Routing

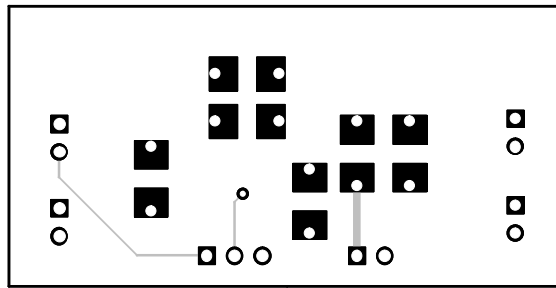

Figure 3. Bottom Layer Routing

3 Schematic

The circuit schematic in [Figure 4](#) shows the connections for all possible components for the six lead SOT23 package. Depending on the LDO being evaluated, some components may be omitted.

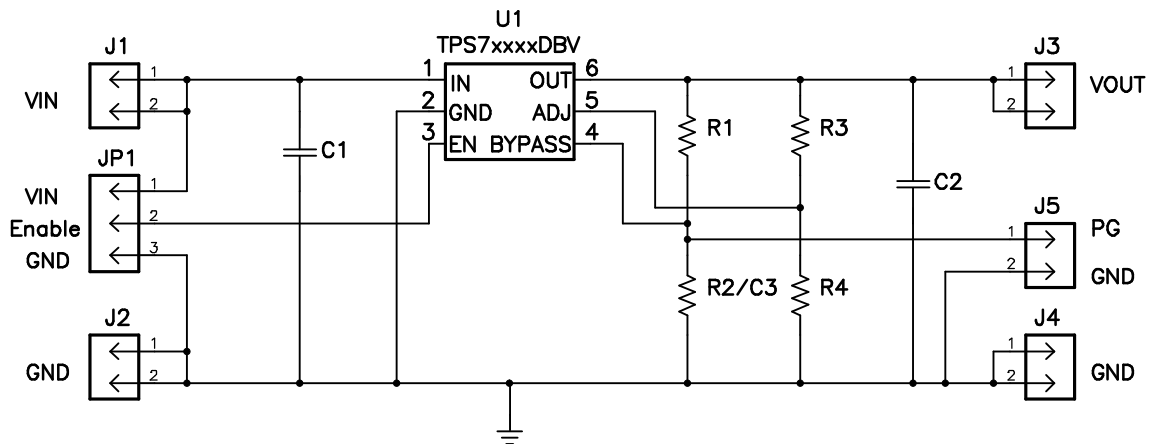

Figure 4. DEM-SOT23LDO Schematic

IMPORTANT NOTICE

Texas Instruments Incorporated and its subsidiaries (TI) reserve the right to make corrections, modifications, enhancements, improvements, and other changes to its products and services at any time and to discontinue any product or service without notice. Customers should obtain the latest relevant information before placing orders and should verify that such information is current and complete. All products are sold subject to TI's terms and conditions of sale supplied at the time of order acknowledgment.

TI warrants performance of its hardware products to the specifications applicable at the time of sale in accordance with TI's standard warranty. Testing and other quality control techniques are used to the extent TI deems necessary to support this warranty. Except where mandated by government requirements, testing of all parameters of each product is not necessarily performed.

TI assumes no liability for applications assistance or customer product design. Customers are responsible for their products and applications using TI components. To minimize the risks associated with customer products and applications, customers should provide adequate design and operating safeguards.

TI does not warrant or represent that any license, either express or implied, is granted under any TI patent right, copyright, mask work right, or other TI intellectual property right relating to any combination, machine, or process in which TI products or services are used. Information published by TI regarding third-party products or services does not constitute a license from TI to use such products or services or a warranty or endorsement thereof. Use of such information may require a license from a third party under the patents or other intellectual property of the third party, or a license from TI under the patents or other intellectual property of TI.

Reproduction of information in TI data books or data sheets is permissible only if reproduction is without alteration and is accompanied by all associated warranties, conditions, limitations, and notices. Reproduction of this information with alteration is an unfair and deceptive business practice. TI is not responsible or liable for such altered documentation.

Resale of TI products or services with statements different from or beyond the parameters stated by TI for that product or service voids all express and any implied warranties for the associated TI product or service and is an unfair and deceptive business practice. TI is not responsible or liable for any such statements.

Following are URLs where you can obtain information on other Texas Instruments products and application solutions:

Products		Applications	
Amplifiers	amplifier.ti.com	Audio	www.ti.com/audio
Data Converters	dataconverter.ti.com	Automotive	www.ti.com/automotive
DSP	dsp.ti.com	Broadband	www.ti.com/broadband
Interface	interface.ti.com	Digital Control	www.ti.com/digitalcontrol
Logic	logic.ti.com	Military	www.ti.com/military
Power Mgmt	power.ti.com	Optical Networking	www.ti.com/opticalnetwork
Microcontrollers	microcontroller.ti.com	Security	www.ti.com/security
		Telephony	www.ti.com/telephony
		Video & Imaging	www.ti.com/video
		Wireless	www.ti.com/wireless

Mailing Address: Texas Instruments
Post Office Box 655303 Dallas, Texas 75265

Looking for pricing, stock, or lifecycle information?

Click below to explore more details on WIN SOURCE:

 [View DEM-SOT23LDO on WIN SOURCE](#)

 [Texas Instruments](#) Information

Optimize Your Supply Chain with WIN SOURCE Solutions

-  Global Sourcing Solution
-  Obsolete Management
-  Cost Control Management
-  Shortage Management
-  Alternative Solution
-  Excess Inventory Management