

Structure : Silicon Monolithic Integrated Circuit

Product : Audio sound controller

Type : **BD3882FV**

- Feature :
1. Dual built-in recording and playing preamplifiers for cassette tapes
Less external components allows a compact size of the set.
 2. The shock sound at power-ON/OFF is absorbed by both power sources.
The reference voltage of signal systems is designed to be a ground level so that low offset voltage and low noise are achieved.

Absolute Maximum Ratings (Ta=25°C)

Parameter	Symbol	Limits	Unit
Power Supply Voltage	VDD	5	V
	VEE	-5	
Power Dissipation	Pd	900※	mW
Operating Temperature	Topr	-20 ~ +75	°C
Storage Temperature	Tastg	-55 ~ +125	°C

※Over Ta=25°C, derating at the rate of 9.0mW/°C.

When installed on the standard board (Size: 70 × 70 × 1.6mm).

Operating Voltage Range

Symbol	Limit	Unit
VDD	3.5 ~ 4.75	V
VEE	-4.75 ~ -3.5	V

(It must function normally at Ta = 25°C)

Application example

Note that ROHM cannot provide adequate confirmation of patents.

The product described in this specification is designed to be used with ordinary electronic equipment or devices (such as audio-visual equipment, office-automation equipment, communications devices, electrical appliances, and electronic toys).

Should you intend to use this product with equipment or devices which require an extremely high level of reliability and the malfunction of which would directly endanger human life (such as medical instruments, transportation equipment, aerospace machinery, nuclear-reactor controllers, fuel controllers and other safety devices), please be sure to consult with our sales representative in advance.

Electrical characteristics

(Ta = 25°C, VDD = 4.5V, VEE = -4.5V, f = 1kHz, Vin = 50mVrms, Rg = 600Ω, RL = 10kΩ, Input Selector = Ach, Front Volume=0dB, Rear Volume=0dB, Bass=0dB, Middle=0dB, Treble=0dB, unless otherwise noted.)

	Parameter	Symbol	Limit			Unit	Conditions
			Min.	Typ.	Max.		
GENERAL	VDD Circuit Current	IQVDD	-	4.5	10.0	mA	Vin = 0Vrms
	VEE Circuit Current	IQVEE	-10.0	-4.5	-		
	Ach Maximum Input Voltage	Vaim	0.6	0.8	-	Vrms	THD(Vout)=1%, BPF = 400~30kHz Front Volume = -6dB Rear Volume = -18dB
	Bch Maximum Input Voltage	Vbim					
	Cch Maximum Input Voltage	Vcim					
	Maximum Input Voltage TP	Vimtp	0.6	0.8	-	Vrms	THD(Vout)=1%, BPF = 400~30kHz GAIN = 10dB, Front Volume = -6dB Rear Volume = -18dB
	Maximum Output Voltage	Vom	2.2	2.5	-	Vrms	THD = 1%, BPF = 400~30kHz
	Voltage Gain	Gv	26	28	30	dB	Gv = 20log(Vout/Vin)
	Channel Balance	CB	-1.5	0	1.5	dB	CB = Gv1-Gv2
	Total Harmonic Distortion Ratio	THD	-	0.01	0.1	%	BPF = 400-30KHz
	Output Noise Voltage *	Vno	-	22	60	μ Vrms	BPF = IHF-A, Rg = 0Ω
	Residual Noise Voltage *	Vmno	-	3	8	μ Vrms	Volume=-∞, BPF = IHF-A, Rg=0Ω
	Cross-talk between Channels *	CT	70	85	-	dB	CT = 20log(Vin/Vout) BPF = IHF-A, Rg = 0Ω
Output Impedance	Rout	-	-	50	Ω		
INPUT	Voltage Gain A	Gva	8	10	12	dB	Rg = 0Ω, BPF = IHF-A Vin=500mVrms
	Voltage Gain B	Gvb					
	Voltage Gain C	Gvc					
	Cross-talk between Selectors A1ch→B1ch *	CTab1	-	-110	-70	dB	
	Cross-talk between Selectors A2ch→B2ch *	CTab2					
	Cross-talk between Selectors B1ch→C1ch *	CTbc1					
	Cross-talk between Selectors B2ch→C2ch *	CTbc2					
	Cross-talk between Selectors C1ch→A1ch *	CTca1					
	Cross-talk between Selectors C2ch→A2ch *	CTca2					
	Selector Output Impedance	Rsout	-	-	50	Ω	
KARA OKE	Karaoke Voltage Gain 1ch mono	Gk1	8	10	12	dB	1ch mono
	Karaoke Voltage Gain 2ch mono	Gk2	8	10	12	dB	2ch mono
	Karaoke Voltage Gain 1ch + 2ch	Gk12	8	10	12	dB	1ch+2ch
RECORDING EQ	Voltage Gain RC	Gvrc	38	40	42	dB	f=10kHz
	Maximum Output Voltage RC	Vomrc	2.2	2.5	-	Vrms	THD=1%, BPF=400~30kHz
	Input conversion Noise Voltage RC	Vnorc	-	1.5	3.0	μ Vrms	Rg = 0Ω, BPF = IHF-A
	Slew Rate RC	Vtr	2	4	-	V/μ S	
PLAY BACK EQ	Voltage Gain TP	Gvtp	44	46	48	dB	f=10kHz
	Maximum Output Voltage TP	Vomtp	2.2	2.5	-	Vrms	THD=1%, BPF=400~30kHz
	Input conversion Noise Voltage TP	Vnotp	-	1.1	2.0	μ Vrms	Rg=2.2kΩ, BPF=IHF-A, Gv=20dB
FRONT VOLUME	Volume Maximum Input Voltage	Vimv	1.5	1.9	-	Vrms	THD(Vout)=1%, BPF=400~30kHz Front Volume ATT=-6dB Rear Volume ATT=-18dB
	Volume Input Impedance	Rvin	14	20	26	KΩ	
	Volume Control Range	Vr	-79	-76	-73	dB	BPF = IHF-A
	Volume Control Step 1	Sv1	-	2	-	dB	0dB to -36dB
	Volume Control Step 2	Sv2	-	4	-	dB	-36dB to -76dB
	Volume Setting Error F	Evf	-2	0	2	dB	0dB to -76dB
Volume Maximum Attenuation *	ATTm	-	-116	-90	dB	Volume = -∞, BPF = IHF-A ATT=20log(Vout/Vin)-18dB	
REAR VOLUME	Volume Control Range	Rvr	-20	-18	-16	dB	BPF=400~30kHz
	Volume Setting Error R	EvR	-2	0	2	dB	All steps

	Parameter	Symbol	Limit			Unit	Conditions
			Min.	Typ.	Max.		
BASS	Bass Boost Control Range	Gbbr	+11	+14	+17	dB	f = 55Hz, Vin = 10mVrms BASS = +14dB
	Bass Cut Control Range	Gbcr	-17	-14	-11	dB	f = 55Hz, Vin = 10mVrms BASS = -14dB
	Bass Control Step	Sbc	-	2	-	dB	f = 55Hz Vin = 10mVrms
	Bass Setting Error (-12dB~12dB)	Ebs1	-2	0	2	dB	
	Bass Setting Error (±14dB)	Ebs2	-3	0	3	dB	
TREBLE	Treble Boost Control Range	Gtbr	+11	+14	+17	dB	f = 10kHz, Vin = 10mVrms TREBLE = +14dB
	Treble Cut Control Range	Gtcr	-17	-14	-11	dB	f = 10kHz, Vin = 10mVrms TREBLE = -14dB
	Treble Control Step	Stc	-	2	-	dB	f = 10kHz Vin = 10mVrms
	Treble Setting Error (-12dB~12dB)	Ets1	-2	0	2	dB	
	Treble Setting Error (±14dB)	Ets2	-3	0	3	dB	
MIDDLE	Middle Boost Control Range	Gmbr	+11	+14	+17	dB	f = 1kHz, Vin = 10mVrms MIDDLE = +14dB
	Middle Cut Control Range	Gmcr	-17	-14	-11	dB	f = 1kHz, Vin = 10mVrms MIDDLE = -14dB
	Middle Control Step	Smc	-	2	-	dB	f = 1kHz Vin = 10mVrms
	Middle Setting Error (-12dB~12dB)	Ems1	-2	0	2	dB	
	Middle Setting Error (±14dB)	Ems2	-3	0	3	dB	

- ※The operational amplifier for PB should be used with the gain of 10dB or above.
- ※The input voltage over 1.9Vrms(Typ.) causes a distortion on the output wave at around the setting of Front Volume=0dB. Therefore, using at 1.9Vrms or less is recommended.
- ※For measurement, VP-9690A (Average value wave detection, Effective value display) IHF-A filter by Matsushita Communication Industrial is used.
- ※Phase relation between Input/Output signal terminals is Equiphase.
- ※Not designed for radiation resistance.

Outline dimension • Marking dimension

Block Diagram

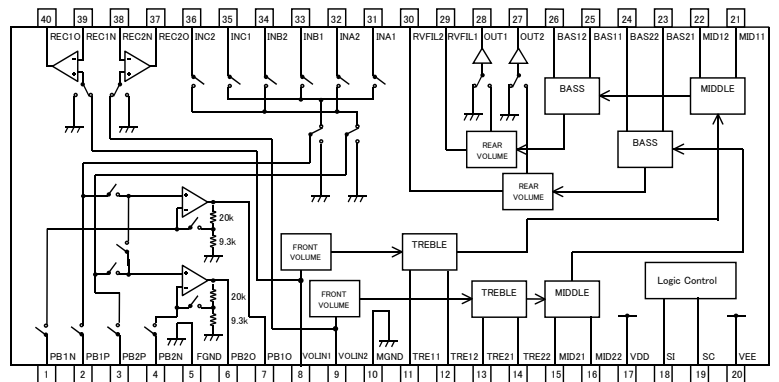
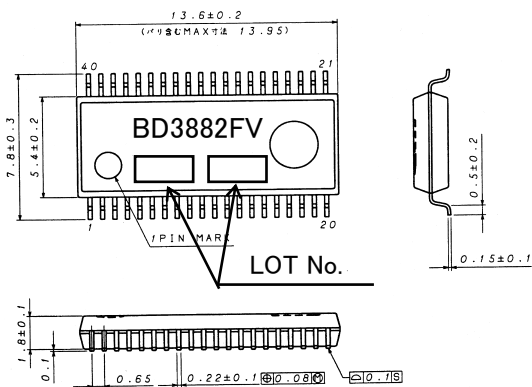

Unit: Resistance = Ω

SSOP-B40 (Unit: mm)

Pin number*Pin name

Pin number	Pin name	Pin number	Pin name	Pin number	Pin name	Pin number	Pin name	Pin number	Pin name
1	PB1N	9	VOLIN2	17	VDD	25	BAS11	33	INB1
2	PB1P	10	MGND	18	SI	26	BAS12	34	INB2
3	PB2P	11	TRE11	19	SC	27	OUT2	35	INC1
4	PB2N	12	TRE12	20	VEE	28	OUT1	36	INC2
5	FGND	13	TRE21	21	MID11	29	RVFIL1	37	REC2O
6	PB2O	14	TRE22	22	MID12	30	RVFIL2	38	REC2N
7	PB1O	15	MID21	23	BAS21	31	INA1	39	REC1N
8	VOLIN1	16	MID22	24	BAS22	32	INA2	40	REC1O

Cautions on use

1. About operating voltage range and operating temperature range

Within the Operating Voltage Range and the Operating Temperature Range, while basic circuit functional operations are supposed to be guaranteed, the standard values of the electrical characteristics are guaranteed only when used under the specific conditions defined within these ranges. Thus, the users must verify those conditions before setting constants, elements, voltages, and temperatures. Note that the conditions of power dissipation are also affected with temperatures.

2. About power on reset

A built-in circuit for performing initialization inside the IC at power-ON is provided. In the case of the set design, however, to be on the safe side, it is recommended that data shall be sent to all the addresses as initial data at power-ON and, until this sending operation is completed, the mute shall be applied.

Function	Initial Condition
Input Selector	MUTE
REC Output	REC MUTE
Karaoke	Stereo
Front Volume	-∞dB
Rear Volume	-18dB
Treble Gain	0dB
Middle Gain	0dB
Bass Gain	0dB

3. About 2-wire serial control

As the terminals of SI and SC are designed for inputting high-frequency digital signals, the wiring and layout patterns should be routed not to cause interference with the analog-signal-related lines.

4. About power ON/OFF

Shock sound absorbing measures at power ON/OFF are implemented on 5pin, 6pin, 16pin, 18pin, 25pin, and 28pin for BD3881FV, as well as on 6pin, 7pin, 27pin, 28pin, 37pin, and 40pin for BD3882FV. When booting up power supplies, the VEE side should be booted a little bit earlier than the other side. If the VDD side is booted up first, an excessive current may pass VDD through VEE. When booting off the power supply, the VDD side should be booted off a little bit earlier than the other side. Note that, at this time, voltage change passing through the GND level may produce an abnormally large current.

5. About function switching

On switching between the Front Volume, Rear Volume, Bass, Middle, Treble, Karaoke, and REC Mute functions, the action has been taken to absorb such switching shock sound. For the other function switching operations, a combined use of MUTE is recommendable.

Notes

No copying or reproduction of this document, in part or in whole, is permitted without the consent of ROHM Co.,Ltd.

The content specified herein is subject to change for improvement without notice.

The content specified herein is for the purpose of introducing ROHM's products (hereinafter "Products"). If you wish to use any such Product, please be sure to refer to the specifications, which can be obtained from ROHM upon request.

Examples of application circuits, circuit constants and any other information contained herein illustrate the standard usage and operations of the Products. The peripheral conditions must be taken into account when designing circuits for mass production.

Great care was taken in ensuring the accuracy of the information specified in this document. However, should you incur any damage arising from any inaccuracy or misprint of such information, ROHM shall bear no responsibility for such damage.

The technical information specified herein is intended only to show the typical functions of and examples of application circuits for the Products. ROHM does not grant you, explicitly or implicitly, any license to use or exercise intellectual property or other rights held by ROHM and other parties. ROHM shall bear no responsibility whatsoever for any dispute arising from the use of such technical information.

The Products specified in this document are intended to be used with general-use electronic equipment or devices (such as audio visual equipment, office-automation equipment, communication devices, electronic appliances and amusement devices).

The Products specified in this document are not designed to be radiation tolerant.

While ROHM always makes efforts to enhance the quality and reliability of its Products, a Product may fail or malfunction for a variety of reasons.

Please be sure to implement in your equipment using the Products safety measures to guard against the possibility of physical injury, fire or any other damage caused in the event of the failure of any Product, such as derating, redundancy, fire control and fail-safe designs. ROHM shall bear no responsibility whatsoever for your use of any Product outside of the prescribed scope or not in accordance with the instruction manual.

The Products are not designed or manufactured to be used with any equipment, device or system which requires an extremely high level of reliability the failure or malfunction of which may result in a direct threat to human life or create a risk of human injury (such as a medical instrument, transportation equipment, aerospace machinery, nuclear-reactor controller, fuel-controller or other safety device). ROHM shall bear no responsibility in any way for use of any of the Products for the above special purposes. If a Product is intended to be used for any such special purpose, please contact a ROHM sales representative before purchasing.

If you intend to export or ship overseas any Product or technology specified herein that may be controlled under the Foreign Exchange and the Foreign Trade Law, you will be required to obtain a license or permit under the Law.





Thank you for your accessing to ROHM product informations.
More detail product informations and catalogs are available, please contact us.

ROHM Customer Support System

<http://www.rohm.com/contact/>

Looking for pricing, stock, or lifecycle information?

Click below to explore more details on WIN SOURCE:

-  [View BD3882FV on WIN SOURCE](#)
-  [Rohm Semiconductor](#) Information

Optimize Your Supply Chain with WIN SOURCE Solutions

-  Global Sourcing Solution
-  Obsolete Management
-  Cost Control Management
-  Shortage Management
-  Alternative Solution
-  Excess Inventory Management