



**THE DATASHEET OF
CC0603ZRY5V6BB225**



TL431LI / TL432LI Programmable Shunt Regulator with Optimized Reference Current

1 Features

- Reference Voltage Tolerance at 25°C
 - 0.5% (B Grade)
 - 1% (A Grade)
- Minimum Typical Output Voltage: 2.495 V
- Adjustable Output Voltage: V_{ref} to 36 V
- Operation From –40°C to +125°C (Q Temp)
- Maximum Temperature Drift
 - 10 mV (C Temp)
 - 17 mV (I Temp)
 - 27 mV (Q Temp)
- 0.3-Ω Typical Output Impedance
- Sink-Current Capability
 - $I_{min} = 1$ mA (max)
 - $I_{KA} = 15$ mA (max)
- Reference Input Current I_{REF} : 0.4 μA (max)
- Deviation of Reference Input Current over Temperature, $I_{I(dev)}$: 0.3 μA (max)

2 Applications

- Adjustable Voltage and Current Referencing
- Secondary Side Regulation in Flyback SMPS
- Zener Diode Replacement
- Voltage Monitoring
- Precision Constant Current Sink/Source
- Comparator with Integrated Reference

3 Description

The TL431LI device is a three-terminal adjustable shunt regulator, with specified thermal stability over applicable automotive, commercial, and military temperature ranges. The output voltage can be set to any value between V_{ref} (approximately 2.495 V) and 36 V, with two external resistors. These devices have a typical output impedance of 0.3 Ω. Active output circuitry provides a very sharp turn-on characteristic, making these devices excellent replacements for Zener diodes in many applications, such as onboard regulation, adjustable power supplies, and switching power supplies. This device is a pin-to-pin alternative to the industry standard TL431, with optimized I_{ref} and I_{Idev} performance. The lower I_{ref} and I_{Idev} values enable designers to achieve higher system accuracy and lower leakage current. The TL432LI device has exactly the same functionality and electrical specifications as the TL431LI device, but has a different pinout for the DBZ package.

The TL431LI device is offered in two grades, with initial tolerances (at 25°C) of 0.5% and 1%, for the B and A grade, respectively. In addition, low output drift versus temperature ensures good stability over the entire temperature range.

The TL43xLIxQ devices are characterized for operation from –40°C to 125°C.

Device Information⁽¹⁾

PART NUMBER	PACKAGE (PIN)	BODY SIZE (NOM)
TL43xLI	SOT-23 (3)	2.90 mm x 1.30 mm

(1) For all available packages, see the orderable addendum at the end of the data sheet.

Simplified Schematic

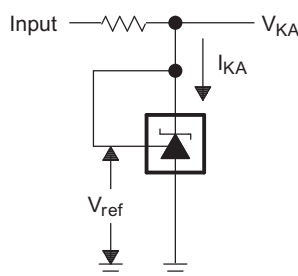

Table of Contents

1 Features	1	9.3 Feature Description	12
2 Applications	1	9.4 Device Functional Modes	12
3 Description	1	10 Applications and Implementation	13
4 Revision History	2	10.1 Application Information	13
5 Device Comparison Table	3	10.2 Typical Applications	13
6 Pin Configuration and Functions	3	10.3 System Examples	21
7 Specifications	4	11 Power Supply Recommendations	24
7.1 Absolute Maximum Ratings	4	12 Layout	24
7.2 ESD Ratings	4	12.1 Layout Guidelines	24
7.3 Thermal Information	4	12.2 Layout Example	25
7.4 Recommended Operating Conditions	4	13 Device and Documentation Support	26
7.5 Electrical Characteristics	5	13.1 Related Links	26
7.6 Typical Characteristics	6	13.2 Documentation Support	26
8 Parameter Measurement Information	9	13.3 Receiving Notification of Documentation Updates	26
8.1 Temperature Coefficient	9	13.4 Community Resources	26
8.2 Dynamic Impedance	10	13.5 Trademarks	27
9 Detailed Description	11	13.6 Electrostatic Discharge Caution	27
9.1 Overview	11	13.7 Glossary	27
9.2 Functional Block Diagram	11	14 Mechanical, Packaging, and Orderable Information	27

4 Revision History

Changes from Original (July 2018) to Revision A	Page
• Changed TL43xLI status from Advance Information to Production Data release	1

5 Device Comparison Table

DEVICE PINOUT	INITIAL ACCURACY	OPERATING FREE-AIR TEMPERATURE (T _A)
TL431LI TL432LI	A: 1% B: 0.5%	C: 0°C to 70°C I: -40°C to 85°C Q: -40°C to 125°C

6 Pin Configuration and Functions

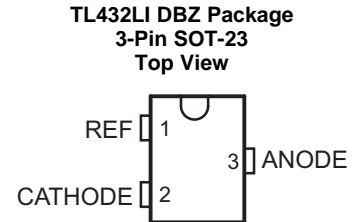
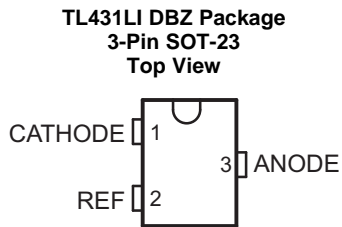

Pin Functions

NAME	PIN NUMBER		TYPE	DESCRIPTION
	TL431LIx	TL432LIx		
	DBZ	DBZ		
ANODE	3	3	O	Common pin, normally connected to ground
CATHODE	1	2	I/O	Shunt Current/Voltage input
REF	2	1	I	Threshold relative to common anode

7 Specifications

7.1 Absolute Maximum Ratings

over operating free-air temperature range (unless otherwise noted)⁽¹⁾

		MIN	MAX	UNIT
V_{KA}	Cathode Voltage ⁽²⁾		37	V
I_{KA}	Continuous Cathode Current Range	-10	18	mA
$I_{I(ref)}$	Reference Input Current	-5	10	mA
T_J	Operating Junction Temperature Range	-40	150	C
T_{stg}	Storage Temperature Range	-65	150	C

- (1) Stresses beyond those listed under *Absolute Maximum Ratings* may cause permanent damage to the device. These are stress ratings only, which do not imply functional operation of the device at these or any other conditions beyond those indicated under *Recommended Operating Conditions*. Exposure to absolute-maximum-rated conditions for extended periods may affect device reliability.
- (2) All voltage values are with respect to ANODE, unless otherwise noted.

7.2 ESD Ratings

		VALUE	UNIT
$V_{(ESD)}$	Electrostatic discharge	Human body model (HBM), per ANSI/ESDA/JEDEC JS-001 pins ⁽¹⁾	±2000
		Charged-device model (CDM), per JEDEC specification JESD22- \pm 1000 VC101 ⁽²⁾	±1000

- (1) JEDEC document JEP155 states that 500-V HBM allows safe manufacturing with a standard ESD control process.
- (2) JEDEC document JEP157 states that 250-V CDM allows safe manufacturing with a standard ESD control process.

7.3 Thermal Information

THERMAL METRIC ⁽¹⁾		TL43xLI	UNIT
		DBZ	
		3 PINS	
$R_{\theta JA}$	Junction-to-ambient thermal resistance	371.7	C/W
$R_{\theta JC(top)}$	Junction-to-case (top) thermal resistance	145.9	C/W
$R_{\theta JB}$	Junction-to-board thermal resistance	104.7	C/W
Ψ_{JT}	Junction-to-top characterization resistance	23.9	C/W
Ψ_{JB}	Junction-to-board characterization resistance	102.9	C/W

- (1) For more information about traditional and new thermal metrics, see the Semiconductor and IC Package Thermal Metrics application report, [SPRA953](#).

7.4 Recommended Operating Conditions

See ⁽¹⁾

		MIN	MAX	UNIT	
V_{KA}	Cathode Voltage	V_{REF}	36	V	
I_{KA}	Continuous Cathode Current Range	1	15	mA	
T_A	Operating Free-Air Temperature	TL43xLIxC	0	70	C
		TL43xLIxI	-40	85	C
		TL43xLIxQ	-40	125	C

- (1) Maximum power dissipation is a function of $T_{J(max)}$, θ_{JA} , and T_A . The maximum allowable power dissipation at any allowable ambient temperature is $P_D = (T_{J(max)} - T_A)/\theta_{JA}$. Operating at the absolute maximum T_J of 150°C can affect reliability.

7.5 Electrical Characteristics

over recommended operating conditions, $T_A = 25^\circ\text{C}$ (unless otherwise noted)

PARAMETER		TEST CIRCUIT	TEST CONDITIONS	MIN	TYP	MAX	UNIT	
V_{ref}	Reference Voltage	See Figure 14	$V_{\text{KA}} = V_{\text{ref}}, I_{\text{KA}} = 1 \text{ mA}$	TL43xLlAx devices	2470	2495	2520	mV
				TL43xLlBx devices	2483	2495	2507	mV
$V_{\text{I(dev)}}$	Deviation of reference input voltage over full temperature range ⁽¹⁾	See Figure 14	$V_{\text{KA}} = V_{\text{ref}}, I_{\text{KA}} = 1 \text{ mA}$	TL43xLlxC devices	2.5	11	mV	
				TL43xLlLxI devices	6	17	mV	
				TL43xLlLxQ devices	10	27	mV	
$\frac{\Delta V_{\text{ref}}}{\Delta V_{\text{KA}}}$	Ratio of change in reference voltage to the change in cathode voltage	See Figure 15	$I_{\text{KA}} = 1 \text{ mA}$	$\Delta V_{\text{KA}} = 10 \text{ V} - V_{\text{ref}}$	-1.4	-2.7	mV/V	
				$\Delta V_{\text{KA}} = 36 \text{ V} - 10 \text{ V}$	-1	-2	mV/V	
I_{ref}	Reference Input Current	See Figure 15	$I_{\text{KA}} = 1 \text{ mA}, R1 = 10\text{k}\Omega, R2 = \infty$		0.2	0.4	μA	
$I_{\text{I(dev)}}$	Deviation of reference input current over full temperature range ⁽¹⁾	See Figure 15	$I_{\text{KA}} = 1 \text{ mA}, R1 = 10\text{k}\Omega, R2 = \infty$		0.1	0.3	μA	
I_{min}	Minimum cathode current for regulation	See Figure 14	$V_{\text{KA}} = V_{\text{ref}}$			1	mA	
I_{off}	Off-state cathode current	See Figure 16	$V_{\text{KA}} = 36 \text{ V}, V_{\text{ref}} = 0$		0.1	1	μA	
$ Z_{\text{KA}} $	Dynamic Impedance ⁽²⁾	See Figure 14	$V_{\text{KA}} = V_{\text{ref}}, I_{\text{KA}} = 1 \text{ mA to } 15 \text{ mA}$		0.3	0.65	Ω	

- (1) The deviation parameters $V_{\text{I(dev)}}$ and $I_{\text{I(dev)}}$ are defined as the differences between the maximum and minimum values obtained over the rated temperature range. For more details on $V_{\text{I(dev)}}$ and how it relates to the average temperature coefficient, see [Parameter Measurement Information](#).
- (2) The dynamic impedance is defined by $|Z_{\text{KA}}| = \Delta V_{\text{KA}} / \Delta I_{\text{KA}}$. For more details on $|Z_{\text{KA}}|$ and how it relates to V_{KA} , see [Parameter Measurement Information](#).

7.6 Typical Characteristics

Data at high and low temperatures are applicable only within the recommended operating free-air temperature ranges of the various devices.

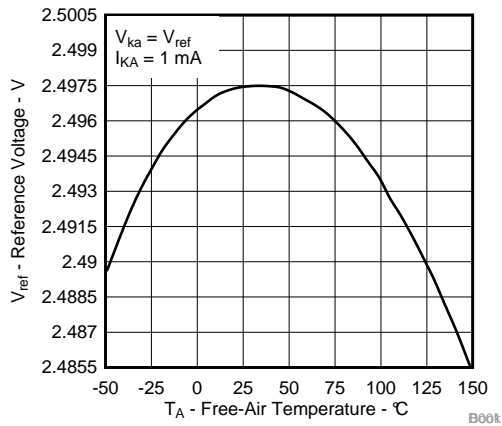

Figure 1. Reference Voltage vs Free-Air Temperature

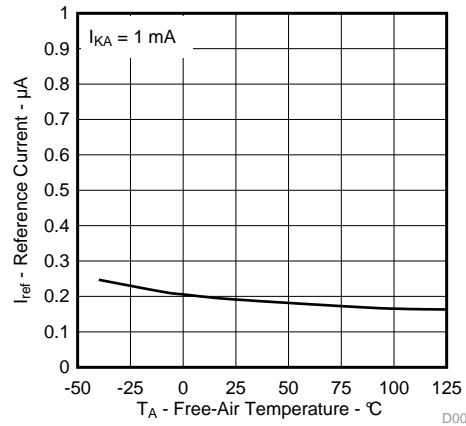

Figure 2. Reference Current vs Free-Air Temperature

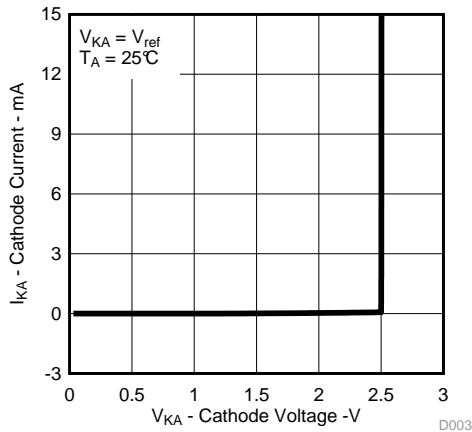

Figure 3. Cathode Current vs Cathode Voltage

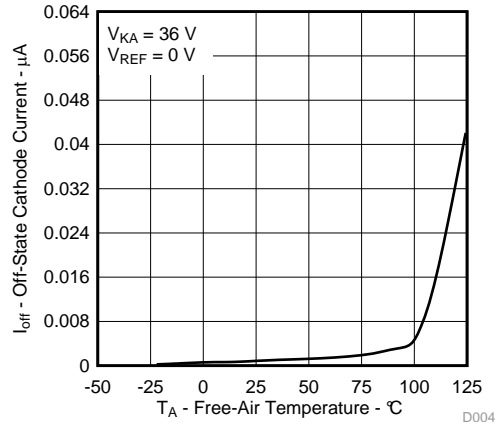

Figure 4. Off-State Cathode Current vs Free-Air Temperature

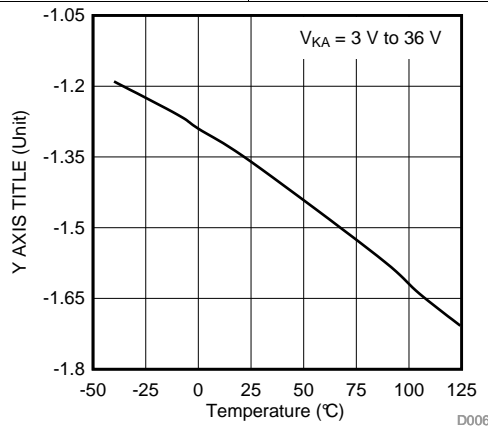

Figure 5. Ratio of Delta Reference Voltage to Delta Cathode Voltage vs Free-Air Temperature

Typical Characteristics (continued)

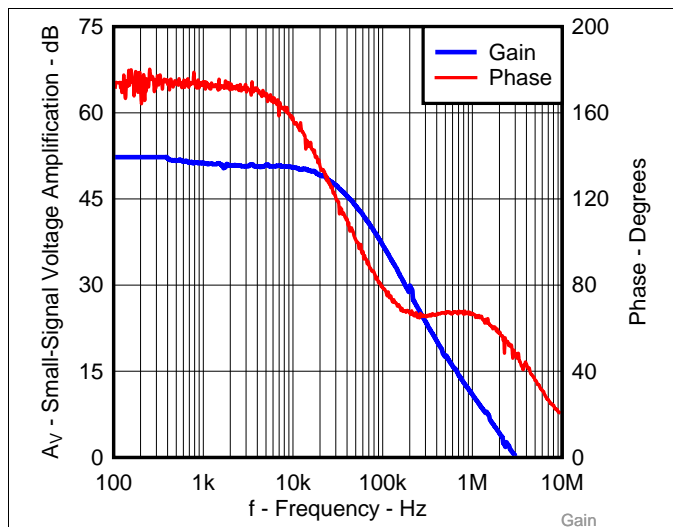

Figure 6. Small-Signal Voltage Amplification vs Frequency

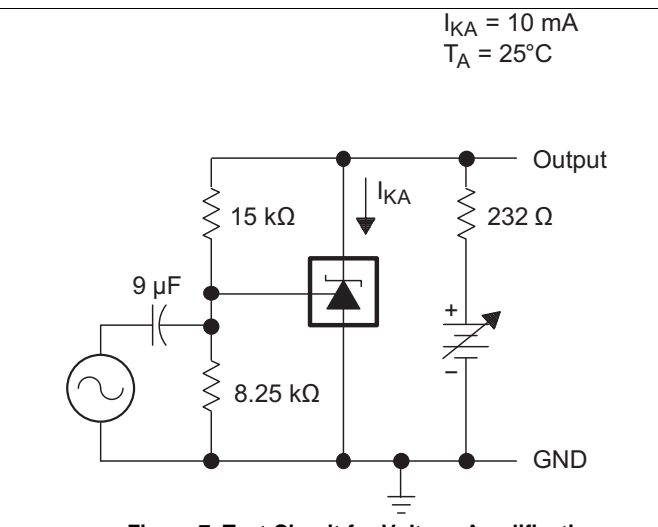

Figure 7. Test Circuit for Voltage Amplification

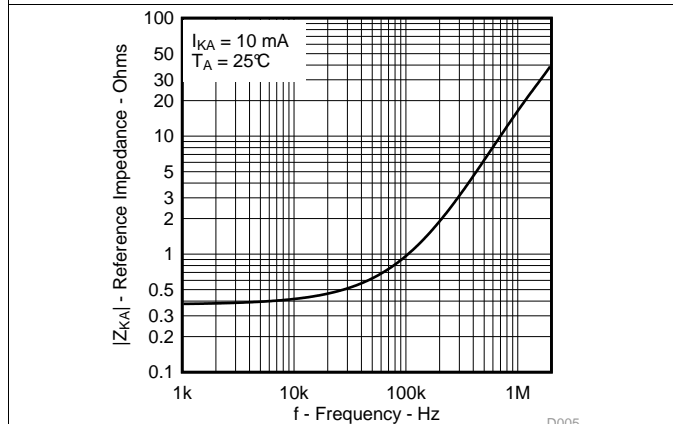

Figure 8. Reference Impedance vs Frequency

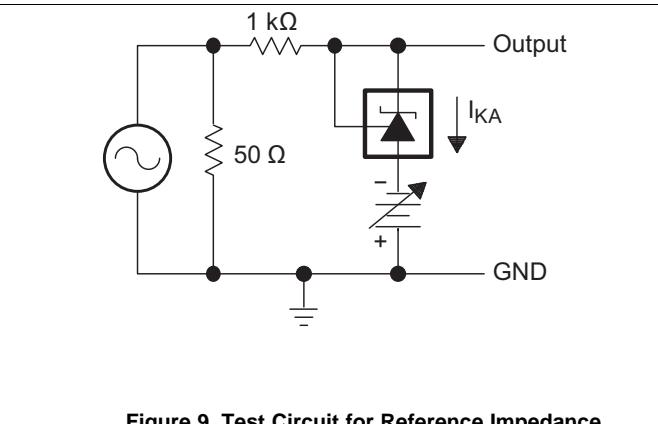

Figure 9. Test Circuit for Reference Impedance

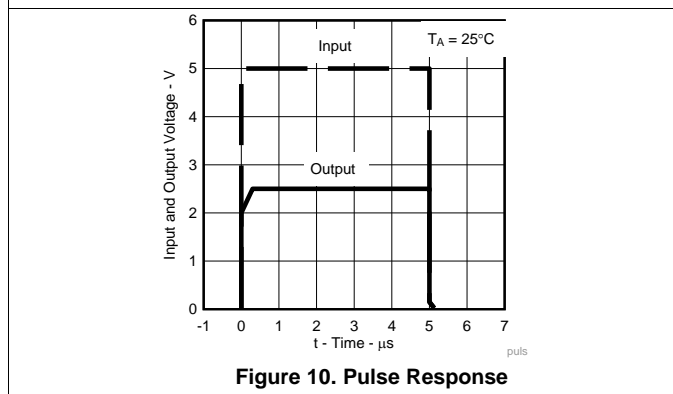

Figure 10. Pulse Response

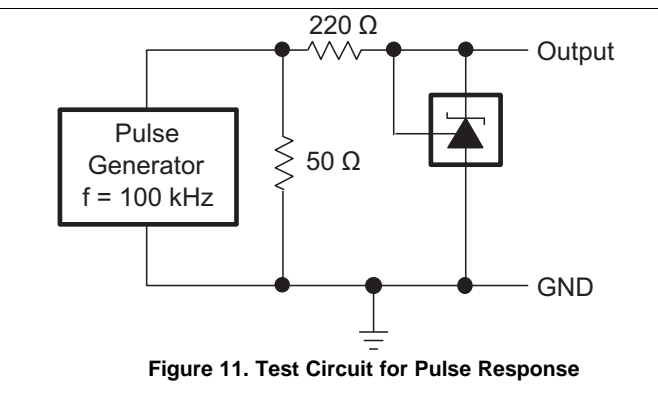
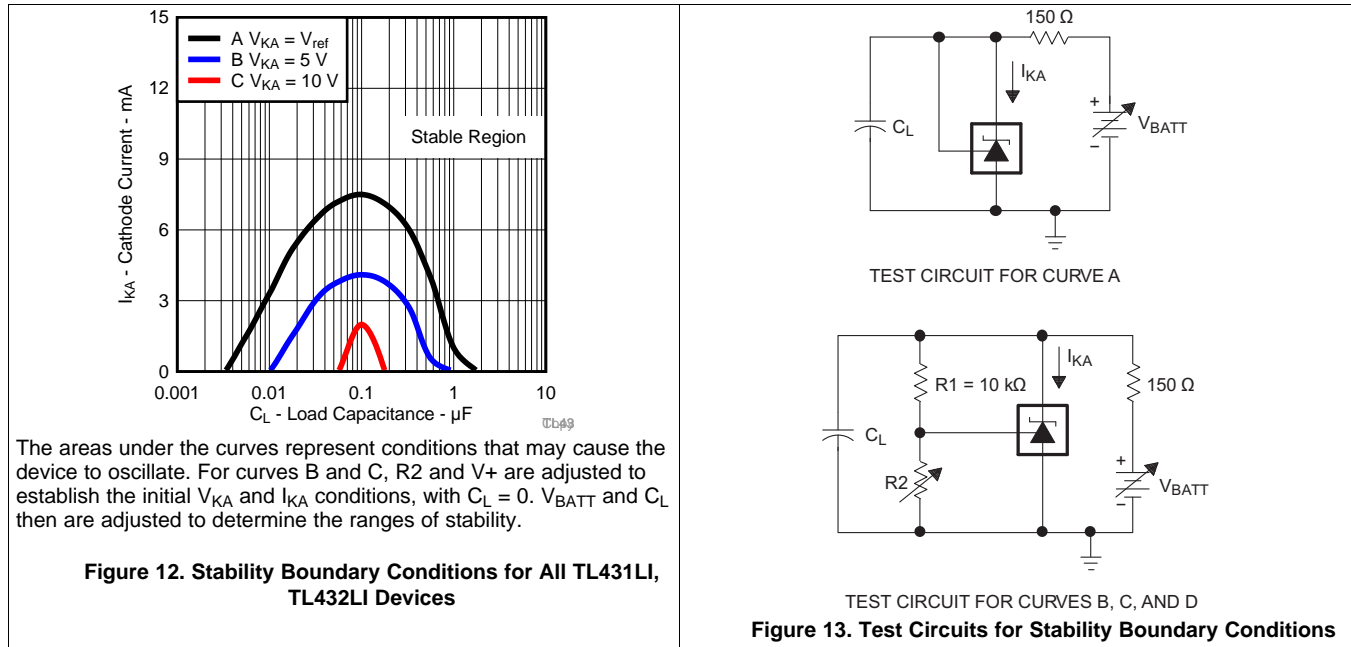

Figure 11. Test Circuit for Pulse Response

Typical Characteristics (continued)



8 Parameter Measurement Information

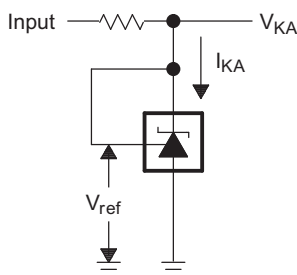

Figure 14. Test Circuit for $V_{KA} = V_{ref}$

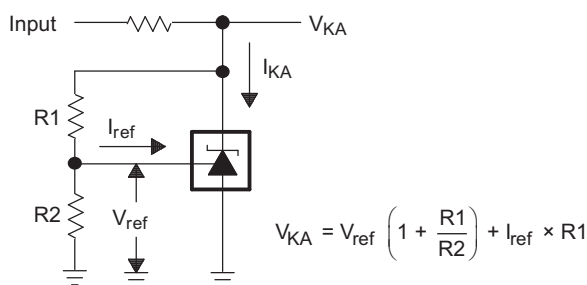

Figure 15. Test Circuit for $V_{KA} > V_{ref}$

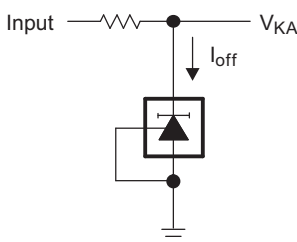

Figure 16. Test Circuit for I_{off}

8.1 Temperature Coefficient

The deviation of the reference voltage, V_{ref} , over the full temperature range is known as $V_{I(dev)}$. The parameter of $V_{I(dev)}$ can be used to find the temperature coefficient of the device. The average full-range temperature coefficient of the reference input voltage, $\alpha_{V_{ref}}$, is defined as:

$$\left| \alpha_{V_{ref}} \right| \left(\frac{\text{ppm}}{^{\circ}\text{C}} \right) = \frac{\left(\frac{V_{I(dev)}}{V_{ref \text{ at } 25^{\circ}\text{C}}} \right) \times 10^6}{\Delta T_A}$$

where:

ΔT_A is the rated operating temperature range of the device.

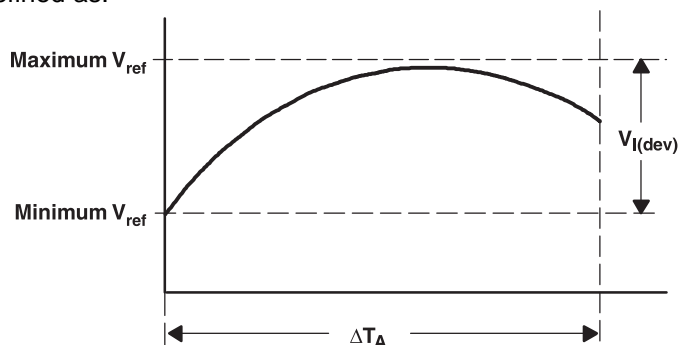

$\alpha_{V_{ref}}$ is positive or negative, depending on whether minimum V_{ref} or maximum V_{ref} , respectively, occurs at the lower temperature. The full-range temperature coefficient is an average and therefore any subsection of the rated operating temperature range can yield a value that is greater or less than the average. For more details on temperature coefficient, check out [Voltage Reference Selection Basics](#).

8.2 Dynamic Impedance

The dynamic impedance is defined as: $|Z_{KA}| = \frac{\Delta V_{KA}}{\Delta I_{KA}}$. When the device is operating with two external resistors (see [Figure 15](#)), the total dynamic impedance of the circuit is given by: $|z| = \frac{\Delta V}{\Delta I}$ which is approximately equal to $|Z_{KA}| \left(1 + \frac{R1}{R2}\right)$.

The V_{KA} of the TL431LI can be affected by the dynamic impedance. The TL431LI test current I_{test} for V_{KA} is specified on the [Electrical Characteristics](#). Any deviation from I_{test} can cause deviation on the output V_{KA} . [Figure 17](#) shows the effect of the dynamic impedance on the V_{KA} .

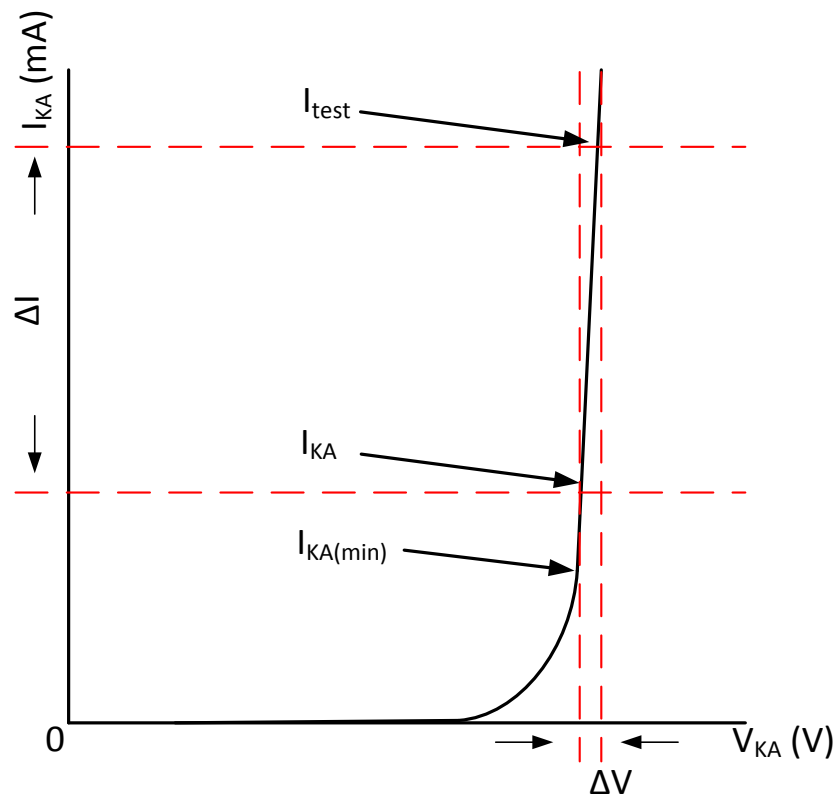

Figure 17. Dynamic Impedance

9 Detailed Description

9.1 Overview

This standard device has proven ubiquity and versatility across a wide range of applications, ranging from power to signal path. This is due to its key components containing an accurate voltage reference and op amp, which are very fundamental analog building blocks. TL43xLI is used in conjunction with its key components to behave as a single voltage reference, error amplifier, voltage clamp or comparator with integrated reference.

TL43xLI can be operated and adjusted to cathode voltages from 2.495V to 36V, making this part optimum for a wide range of end equipments in industrial, auto, telecom and computing. In order for this device to behave as a shunt regulator or error amplifier, $>1\text{mA}$ ($I_{\text{min(max)}}$) must be supplied in to the cathode pin. Under this condition, feedback can be applied from the Cathode and Ref pins to create a replica of the internal reference voltage.

Various reference voltage options can be purchased with initial tolerances (at 25°C) of 0.5%, and 1%. These reference options are denoted by B (0.5%) and A (1.0%) after the TL431LI or TL432LI. TL431LI and TL432LI are both functionally the same, but have separate pinout options.

The TL43xLIxC devices are characterized for operation from 0°C to 70°C, the TL43xLIxI devices are characterized for operation from -40°C to 85°C, and the TL43xLIxQ devices are characterized for operation from -40°C to 125°C.

9.2 Functional Block Diagram

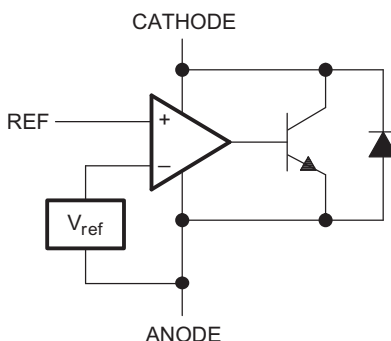

Figure 18. Equivalent Schematic

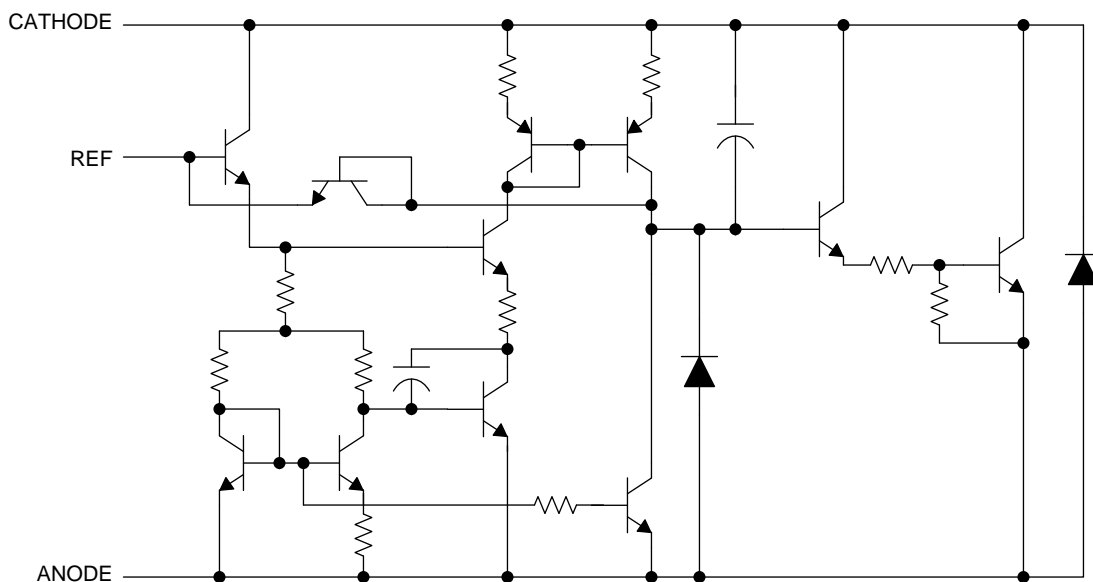

Figure 19. Detailed Schematic

9.3 Feature Description

TL43xLI consists of an internal reference and amplifier that outputs a sink current based on the difference between the reference pin and the virtual internal pin. The sink current is produced by the internal Darlington pair, shown in the above schematic ([Figure 19](#)). A Darlington pair is used in order for this device to be able to sink a maximum current of 15 mA.

When operated with enough voltage headroom (≥ 2.495 V) and cathode current (I_{KA}), TL43xLI forces the reference pin to 2.495 V. However, the reference pin can not be left floating, as it needs $I_{REF} \geq 0.4$ μ A (please see [Specifications](#)). This is because the reference pin is driven into an npn, which needs base current in order to operate properly.

When feedback is applied from the Cathode and Reference pins, TL43xLI behaves as a Zener diode, regulating to a constant voltage dependent on current being supplied into the cathode. This is due to the internal amplifier and reference entering the proper operating regions. The same amount of current needed in the above feedback situation must be applied to this device in open loop, servo or error amplifying implementations in order for it to be in the proper linear region giving TL43xLI enough gain.

Unlike many linear regulators, TL43xLI is internally compensated to be stable without an output capacitor between the cathode and anode. However, if it is desired to use an output capacitor [Figure 12](#) can be used as a guide to assist in choosing the correct capacitor to maintain stability.

9.4 Device Functional Modes

9.4.1 Open Loop (Comparator)

When the cathode/output voltage or current of TL43xLI is not being fed back to the reference/input pin in any form, this device is operating in open loop. With proper cathode current (I_{KA}) applied to this device, TL43xLI will have the characteristics shown in [Figure 18](#). With such high gain in this configuration, TL43xLI is typically used as a comparator. With the reference integrated makes TL43xLI the preferred choice when users are trying to monitor a certain level of a single signal. Look at [SLVA987](#) for more details on open loop comparator applications on the TL431LI.

9.4.2 Closed Loop

When the cathode/output voltage or current of TL43xLI is being fed back to the reference/input pin in any form, this device is operating in closed loop. The majority of applications involving TL43xLI use it in this manner to regulate a fixed voltage or current. The feedback enables this device to behave as an error amplifier, computing a portion of the output voltage and adjusting it to maintain the desired regulation. This is done by relating the output voltage back to the reference pin in a manner to make it equal to the internal reference voltage, which can be accomplished through resistive or direct feedback.

10 Applications and Implementation

NOTE

Information in the following applications sections is not part of the TI component specification, and TI does not warrant its accuracy or completeness. TI's customers are responsible for determining suitability of components for their purposes. Customers should validate and test their design implementation to confirm system functionality.

10.1 Application Information

As this device has many applications and setups, there are many situations that this datasheet can not characterize in detail. The linked application notes help the designer make the best choices when using this part.

Application note [Designing with the Improved TL431LI](#), SNOAA00 provides a deeper understanding of this device's accuracy in a flyback optocoupler application. Application note [Setting the Shunt Voltage on an Adjustable Shunt Regulator](#), SLVA445 assists designers in setting the shunt voltage to achieve optimum accuracy for this device.

10.2 Typical Applications

10.2.1 Comparator With Integrated Reference

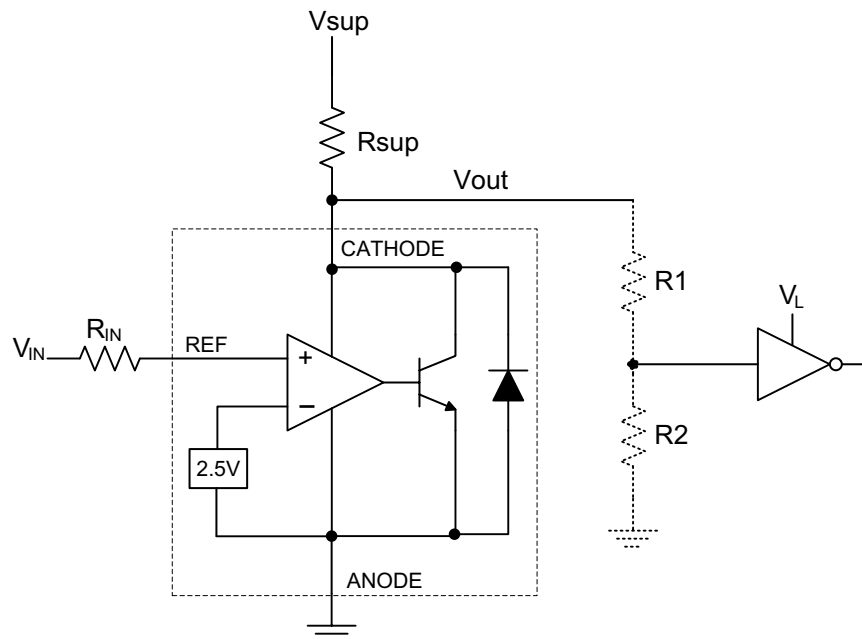

Figure 20. Comparator Application Schematic

Typical Applications (continued)

10.2.1.1 Design Requirements

For this design example, use the parameters listed in [Table 1](#) as the input parameters.

Table 1. Design Parameters

DESIGN PARAMETER	EXAMPLE VALUE
Input Voltage Range	0 V to 5 V
Input Resistance	10 k Ω
Supply Voltage	24 V
Cathode Current (I_K)	5 mA
Output Voltage Level	$\sim 2\text{ V} - V_{SUP}$
Logic Input Thresholds V_{IH}/V_{IL}	V_L

10.2.1.2 Detailed Design Procedure

When using TL43xLI as a comparator with reference, determine the following:

- Input Voltage Range
- Reference Voltage Accuracy
- Output logic input high and low level thresholds
- Current Source resistance

10.2.1.2.1 Basic Operation

In the configuration shown in [Figure 20](#) TL43xLI will behave as a comparator, comparing the V_{REF} pin voltage to the internal virtual reference voltage. When provided a proper cathode current (I_K), TL43xLI will have enough open loop gain to provide a quick response. This can be seen in [Figure 21](#), where the $R_{SUP}=10\text{ k}\Omega$ ($I_{KA}=500\text{ }\mu\text{A}$) situation responds much slower than $R_{SUP}=1\text{ k}\Omega$ ($I_{KA}=5\text{ mA}$). With the TL43xLI max Operating Current (I_{MIN}) being 1 mA, operation below that could result in low gain, leading to a slow response.

10.2.1.2.1.1 Overdrive

Slow or inaccurate responses can also occur when the reference pin is not provided enough overdrive voltage. This is the amount of voltage that is higher than the internal virtual reference. The internal virtual reference voltage will be within the range of $2.495\text{ V} \pm(0.5\% \text{ or } 1.0\%)$ depending on which version is being used. The more overdrive voltage provided, the faster the TL43xLI will respond.

For applications where TL43xLI is being used as a comparator, it is best to set the trip point to greater than the positive expected error (that is +1.0% for the A version). For fast response, setting the trip point to >10% of the internal V_{REF} should suffice.

For minimal voltage drop or difference from V_{in} to the ref pin, TI recommends to use an input resistor <10 k Ω to provide I_{ref} .

10.2.1.2.2 Output Voltage and Logic Input Level

In order for TL43xLI to properly be used as a comparator, the logic output must be readable by the receiving logic device. This is accomplished by knowing the input high and low level threshold voltage levels, typically denoted by V_{IH} and V_{IL} .

As seen in [Figure 21](#), TL43xLI's output low level voltage in open-loop/comparator mode is approximately 2 V, which is typically sufficient for 5 V supplied logic. However, would not work for 3.3 V and 1.8 V supplied logic. To accommodate this a resistive divider can be tied to the output to attenuate the output voltage to a voltage legible to the receiving low voltage logic device.

TL43xLI's output high voltage is equal to V_{SUP} due to TL43xLI being open-collector. If V_{SUP} is much higher than the receiving logic's maximum input voltage tolerance, the output must be attenuated to accommodate the outgoing logic's reliability.

When using a resistive divider on the output, be sure to make the sum of the resistive divider (R_1 and R_2 in [Figure 20](#)) is much greater than R_{SUP} in order to not interfere with TL43xLI's ability to pull close to V_{SUP} when turning off.

10.2.1.2.2.1 Input Resistance

TL43xLI requires an input resistance in this application in order to source the reference current (I_{REF}) needed from this device to be in the proper operating regions while turning on. The actual voltage seen at the ref pin will be $V_{REF} = V_{IN} - I_{REF}R_{IN}$. Because I_{REF} can be as high as $0.4 \mu A$ it is recommended to use a resistance small enough that will mitigate the error that I_{REF} creates from V_{IN} .

10.2.1.3 Application Curve

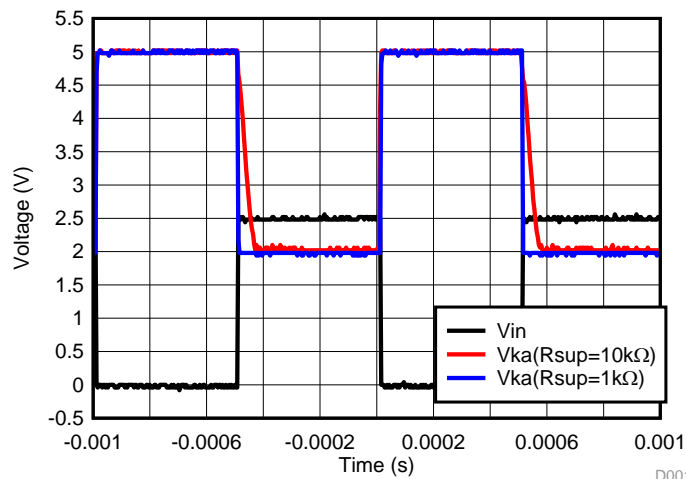
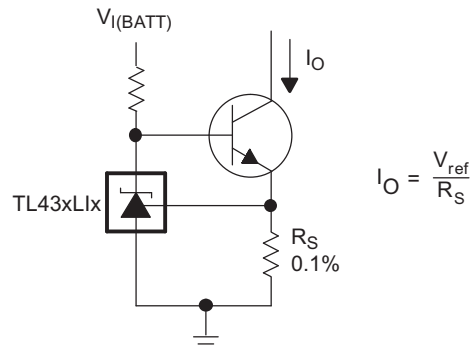

Figure 21. Output Response With Various Cathode Currents

10.2.2 Precision Constant Current Sink



Copyright © 2017, Texas Instruments Incorporated

Figure 22. Precision Constant Current Sink Application Schematic

10.2.2.1 Design Requirements

For this design example, use the parameters listed in [Table 1](#) as the input parameters.

Table 2. Design Parameters

DESIGN PARAMETER	EXAMPLE VALUE
Supply Voltage ($V_{I(BATT)}$)	5 V
Sink Current (I_O)	100mA
Cathode Current (I_k)	5 mA

10.2.2.2 Detailed Design Procedure

When using TL43xLI as a constant current sink, determine the following:

- Output Current Range
- Output Current Accuracy
- Power Consumption for TL43xLI

10.2.2.2.1 Basic Operation

In the configuration shown, TL43xLI acts as a control component within a feedback loop of the constant current sink. Working with an external passing component such as an BJT, TL43xLI provides precision current sink with accuracy set by itself and the sense resistor R_S . This circuit can also be used as LED driving circuit.

10.2.2.2.1.1 Output Current Range and Accuracy

The output current range of the circuit is determined by the equation shown in the configuration. Keep in mind that the V_{REF} equals to 2.495V. When choosing the sense resistor R_S , it needs to generate 2.495V for the TL43xLI when I_O reaches the target current. If the overhead voltage of 2.495V is not acceptable, please consider lower voltage reference devices such as TLV43x or TLVH43x.

The output current accuracy is determined by both the accuracy of TL43xLI chosen, as well as the accuracy of the sense resistor R_S . The internal virtual reference voltage of TL43xLI will be within the range of 2.495 V \pm (0.5% or 1.0%) depending on which version is being used. Another consideration for the output current accuracy is the temperature coefficient of the TL43xLI and R_S . Please refer to the electrical characterization table for the specification of these parameters.

10.2.2.2.2 Power Consumption

In order for TL43xLI to properly be used as a control component in this circuit, the minimum operating current needs to be reached. This is accomplished by setting the external biasing resistor in series with the TL43xLI.

For TL43xLI, the minimum operating current is 1mA and with margin consideration, most of the designs set this current to be higher than 1mA. To achieve lower power consumption, please consider devices such as ATL43x and ATL43xLI.

10.2.3 Shunt Regulator/Reference

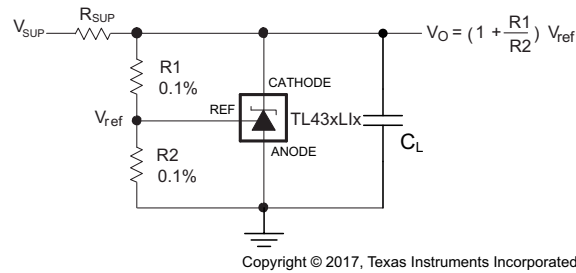

Figure 23. Shunt Regulator Schematic

10.2.3.1 Design Requirements

For this design example, use the parameters listed in [Table 1](#) as the input parameters.

Table 3. Design Parameters

DESIGN PARAMETER	EXAMPLE VALUE
Reference Initial Accuracy	1.0 %
Supply Voltage	24 V
Cathode Current (I _k)	5 mA
Output Voltage Level	2.495 V - 36 V
Load Capacitance	2 μF
Feedback Resistor Values and Accuracy (R1 and R2)	10 kΩ

10.2.3.2 Detailed Design Procedure

When using TL43xLI as a Shunt Regulator, determine the following:

- Input Voltage Range
- Temperature Range
- Total Accuracy
- Cathode Current
- Reference Initial Accuracy
- Output Capacitance

10.2.3.2.1 Programming Output/Cathode Voltage

In order to program the cathode voltage to a regulated voltage a resistive bridge must be shunted between the cathode and anode pins with the mid point tied to the reference pin. This can be seen in [Figure 23](#), with R1 and R2 being the resistive bridge. The cathode/output voltage in the shunt regulator configuration can be approximated by the equation shown in [Figure 23](#). The cathode voltage can be more accurately determined by taking in to account the cathode current:

$$V_O = (1 + R1/R2)V_{REF} - I_{REF}R1 \quad (1)$$

In order for this equation to be valid, TL43xLI must be fully biased so that it has enough open loop gain to mitigate any gain error. This can be done by meeting the I_{min} spec denoted in [Specifications](#).

10.2.3.2.2 Total Accuracy

When programming the output above unity gain ($V_{KA}=V_{REF}$), TL43xLI is susceptible to other errors that may effect the overall accuracy beyond V_{REF} . These errors include:

- R1 and R2 accuracies
- $V_{I(dev)}$ - Change in reference voltage over temperature
- $\Delta V_{REF} / \Delta V_{KA}$ - Change in reference voltage to the change in cathode voltage
- $|z_{KA}|$ - Dynamic impedance, causing a change in cathode voltage with cathode current

Worst case cathode voltage can be determined taking all of the variables in to account. Application note [Setting the Shunt Voltage on an Adjustable Shunt Regulator](#), SLVA445 assists designers in setting the shunt voltage to achieve optimum accuracy for this device.

10.2.3.2.3 Stability

Though TL43xLI is stable with no capacitive load, the device that receives the shunt regulator's output voltage could present a capacitive load that is within the TL43xLI region of stability, shown in [Figure 12](#). Also, designers may use capacitive loads to improve the transient response or for power supply decoupling. When using additional capacitance between Cathode and Anode, refer to [Figure 12](#). Also, application note [Understanding Stability Boundary Conditions Charts in TL431, TL432 Data Sheet](#), SLVA482 provides a deeper understanding of this devices stability characteristics and aid the user in making the right choices when choosing a load capacitor.

10.2.3.2.4 Start-up Time

As shown in [Figure 24](#), TL43xLI has a fast response up to approximately 2 V and then slowly charges to it's programmed value. This is due to the compensation capacitance (shown in [Figure 19](#)) the TL43xLI has to meet it's stability criteria. Despite the secondary delay, TL43xLI still has a fast response suitable for many clamp applications.

10.2.3.3 Application Curve

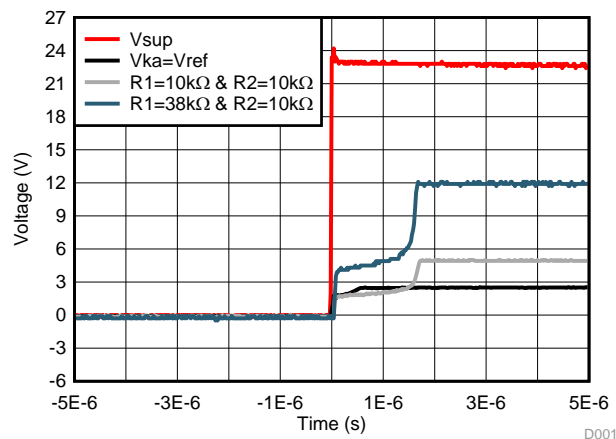
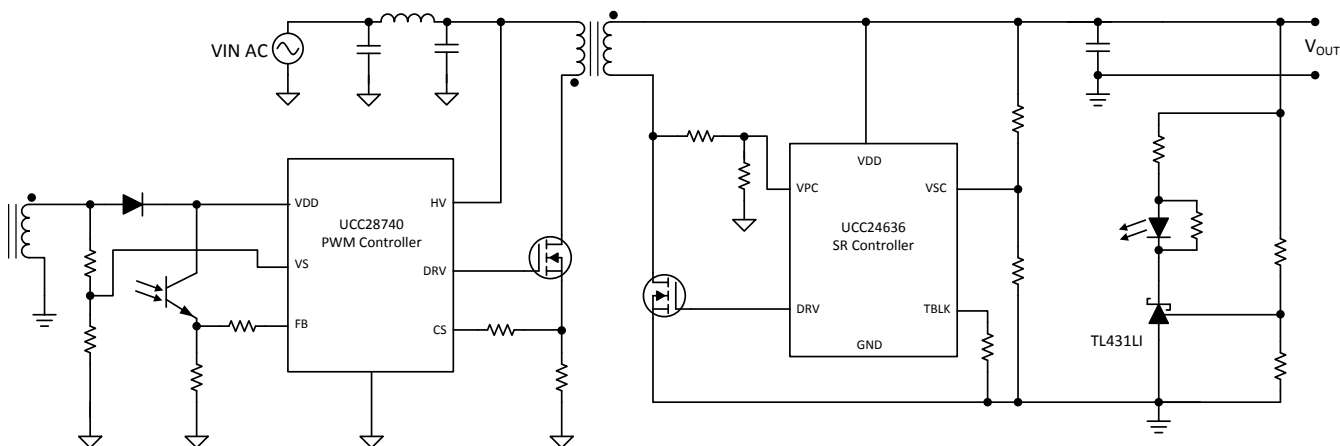

Figure 24. TL43xLI Start-Up Response

10.2.4 Isolated Flyback with Optocoupler



Copyright © 2018, Texas Instruments Incorporated

Figure 25. Isolated Flyback with Optocoupler

10.2.4.1 Design Requirements

The TL431LI is used in the feedback network on the secondary side in an isolated flyback with optocoupler design. Figure 25 shows the simplified flyback converter with the TL431LI. For this design example, use the parameters in Table 4 as the input parameters. In this example, a simplified design procedure will be discussed. The compensation network for the feedback network is beyond the scope of this section. Details on compensation network can be found on SLUA671.

Table 4. Design Parameters

DESIGN PARAMETER	EXAMPLE VALUE
Voltage Output	15 V
Secondary Side Feedback Loop Accuracy	< 3%

10.2.4.1.1 Detailed Design Procedure

The goal of this design is to design a high accuracy feedback network to meet 3% V_{OUT} accuracy requirements over the full temperature range. To meet the design requirements, the total secondary side feedback loop error will have to be below 3%. In order to meet these requirements it is necessary to take full advantage of the improved temperature drift, $I_{ref(min)}$, and $I_{I(dev)}$ of the TL431LI.

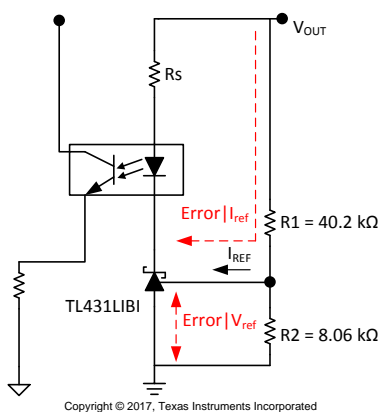

Copyright © 2017, Texas Instruments Incorporated

Figure 26. Feedback Quiescent Current

10.2.4.1.1.1 TL431 Feedback Loop Error Calculation

Figure 26 shows the simplified version of the feedback network. The accuracy of the output voltage is dependent on the regulation voltage accuracy of the TL431LI. A simplified V_{OUT} can be seen in Equation 2 but this equation does not include errors that will deviate the output.

$$V_{OUT} = V_{ref} \times \left(1 + \frac{R1}{R2}\right) + R1 \times (I_{ref})$$

$$V_{OUT} = (2.495 \text{ V}) \times \left(1 + \frac{40.2 \text{ k}\Omega}{8.06 \text{ k}\Omega}\right) + 40.2 \text{ k}\Omega \times (0.4 \mu\text{A})$$

$$V_{OUT} = 14.955 \text{ V} \tag{2}$$

The primary sources of error are the $\text{Error}|_{V_{ref}}$ and $\text{Error}|_{I_{ref}}$. The $\text{Error}|_{V_{ref}}$ primarily consists of the errors that affect the internal bandgap voltage reference of the TL431LI. This consists of errors from the initial accuracy, temperature drift, ratio of change in reference voltage to the change in cathode voltage, and dynamic impedance. The benefit of the TL431LI is its low temperature drift, $V_{I(dev)}$, which allows the V_{ref} to be more accurate across the full temperature range compared to typical TL431LI devices. Equation 3 shows a simplified worst case V_{ref} with initial accuracy and temperature drift.

$$V_{ref}(\text{Error}|_{V_{ref}}) = V_{ref} \times (1 + \text{Initial Accuracy}) + V_{I(dev)} + \dots$$

$$V_{ref}(\text{Error}|_{V_{ref}}) = 2.495 \text{ V} \times (1 + 0.5\%) + 17 \text{ mV} + \dots$$

$$V_{ref}(\text{Error}|_{V_{ref}}) \approx 2.524 \text{ V} \tag{3}$$

The $\text{Error}|_{I_{ref}}$ in Figure 26 is dependent on the I_{ref} and $I_{I(dev)}$ along with R1. The TL431LI has improved I_{ref} and $I_{I(dev)}$ which allows the values of the resistor R1 to be increased to save power. Typically optocoupler feedback design requires the I_{ref} to be taken into account when doing V_{OUT} calculations but the error comes from the deviation from the maximum to typical value of I_{ref} . In addition to this, the $I_{I(dev)}$ is the temperature deviation on the I_{ref} current which will affect the overall reference current into the TL431LI. Equation 4 shows the V_{OUT} of the TL431LI for Figure 26 which includes the improved I_{ref} and $I_{I(dev)}$. The V_{OUT} equation assumes that the resistors R1 and R2 have a 0.5% accuracy tolerance.

$$V_{OUT}(\text{Error}|_{I_{ref}}) = V_{ref}(\text{Error}|_{V_{ref}}) \times \left(1 + \frac{R1}{R2}\right) + R1 \times (I_{ref} + I_{I(dev)})$$

$$V_{OUT}(\text{Error}|_{I_{ref}}) = (2.495 \text{ V} \times (1 + 0.5\%) + 0.017 \text{ V}) \times \left(1 + \frac{40.2 \text{ k}\Omega \times (1 + 0.5\%)}{8.06 \text{ k}\Omega \times (1 - 0.5\%)}\right)$$

$$+ 40.2 \text{ k}\Omega \times (1 + 0.5\%) \times (0.4 \mu\text{A} + 0.3 \mu\text{A})$$

$$V_{OUT} = 15.270 \text{ V} \tag{4}$$

Comparing the calculated V_{OUT} without and without error the expected worst case max error is 2.1% which meets the 3% error target.

10.3 System Examples

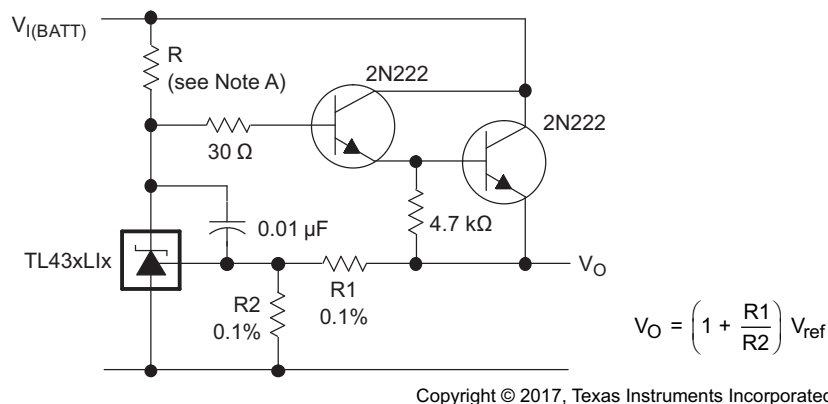

A. R should provide cathode current ≥ 1 mA to the TL431LI at minimum $V_{(BATT)}$.

Figure 27. Precision High-Current Series Regulator

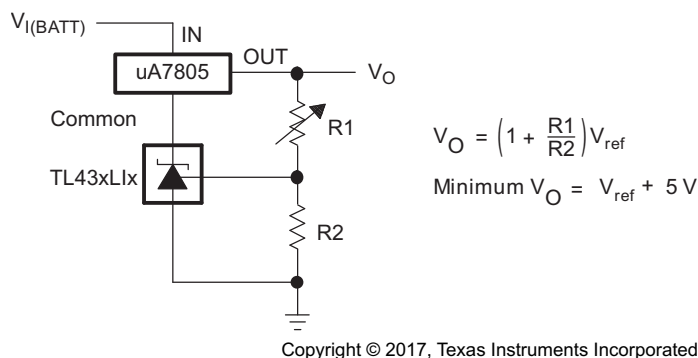

Figure 28. Output Control of a Three-Terminal Fixed Regulator

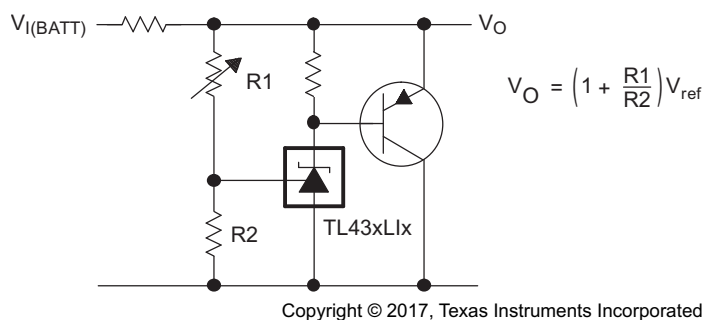
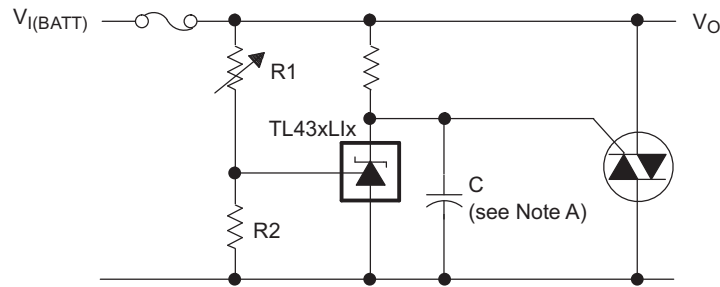

Figure 29. High-Current Shunt Regulator

System Examples (continued)



Copyright © 2017, Texas Instruments Incorporated

- A. Refer to the stability boundary conditions in [Figure 12](#) to determine allowable values for C.

Figure 30. Crowbar Circuit

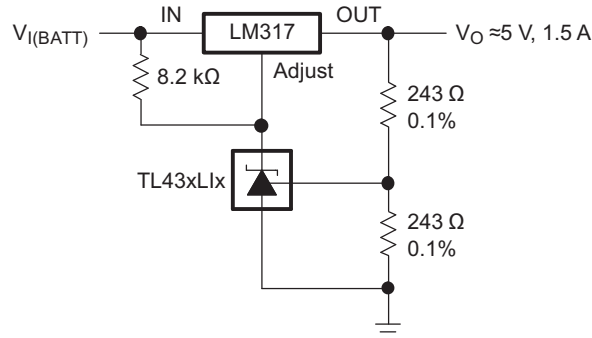

Copyright © 2017, Texas Instruments Incorporated

Figure 31. Precision 5-V, 1.5-A Regulator

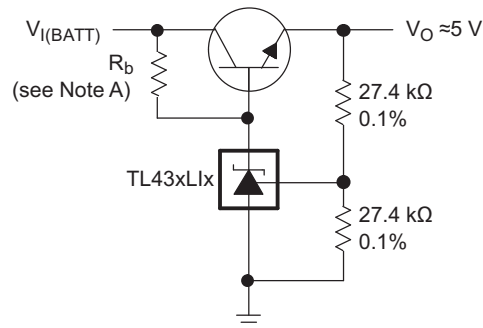

Copyright © 2017, Texas Instruments Incorporated

- A. R_b should provide cathode current ≥ 1 mA to the TL431LI.

Figure 32. Efficient 5-V Precision Regulator

System Examples (continued)

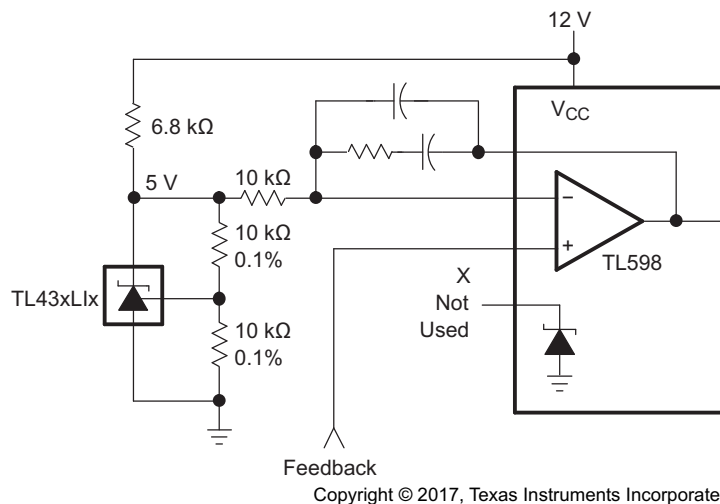
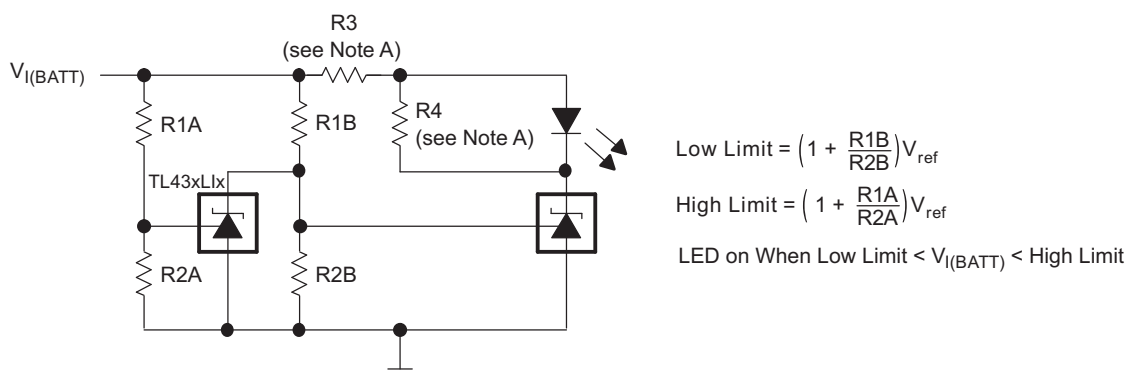

Figure 33. PWM Converter With Reference



- A. Select R3 and R4 to provide the desired LED intensity and cathode current ≥ 1 mA to the TL431LI at the available V_{I(BATT)}.

Figure 34. Voltage Monitor

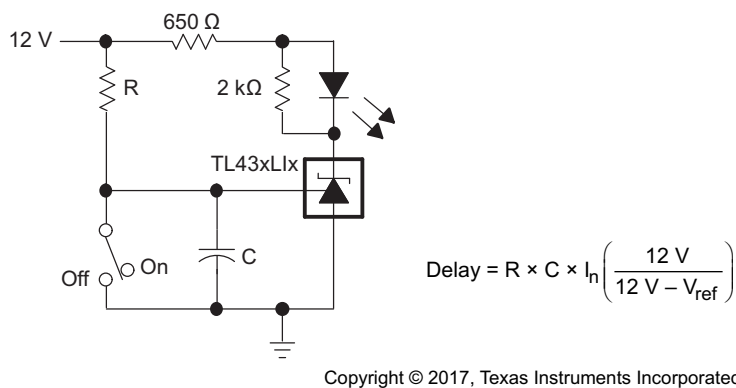

Figure 35. Delay Timer

System Examples (continued)

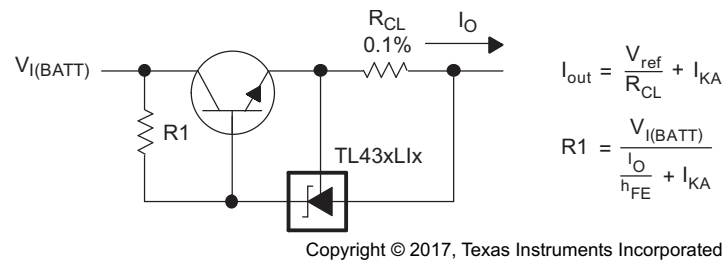

Figure 36. Precision Current Limiter

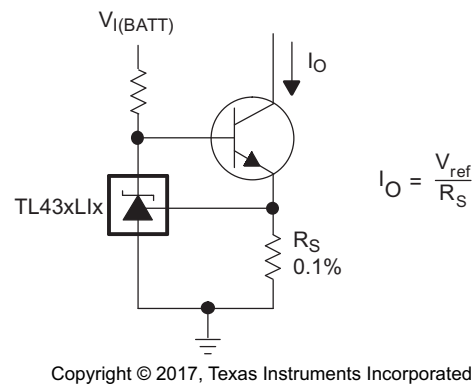

Figure 37. Precision Constant-Current Sink

11 Power Supply Recommendations

When using TL43xLI as a Linear Regulator to supply a load, designers typically use a bypass capacitor on the output/cathode pin. When doing this, be sure that the capacitance is within the stability criteria shown in [Figure 12](#).

In order to not exceed the maximum cathode current, be sure that the supply voltage is current limited. Also, be sure to limit the current being driven into the Ref pin, as not to exceed its absolute maximum rating.

For applications shunting high currents, pay attention to the cathode and anode trace lengths, adjusting the width of the traces to have the proper current density.

12 Layout

12.1 Layout Guidelines

Bypass capacitors should be placed as close to the part as possible. Current-carrying traces need to have widths appropriate for the amount of current they are carrying; in the case of the TL43xLI, these currents are low.

12.2 Layout Example

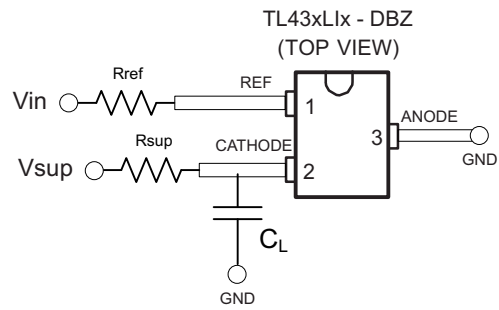

Copyright © 2017, Texas Instruments Incorporated

Figure 38. DBZ Layout example

13 Device and Documentation Support

13.1 Related Links

The table below lists quick access links. Categories include technical documents, support and community resources, tools and software, and quick access to order now.

Table 5. Related Links

PARTS	PRODUCT FOLDER	ORDER NOW	TECHNICAL DOCUMENTS	TOOLS & SOFTWARE	SUPPORT & COMMUNITY
TL431LI	Click here	Click here	Click here	Click here	Click here
TL432LI	Click here	Click here	Click here	Click here	Click here

13.2 Documentation Support

13.2.1 Device Nomenclature

TI assigns suffixes and prefixes to differentiate all the combinations of the TL43xLI family. More details and possible orderable combinations are located in the Package Option Addendum.

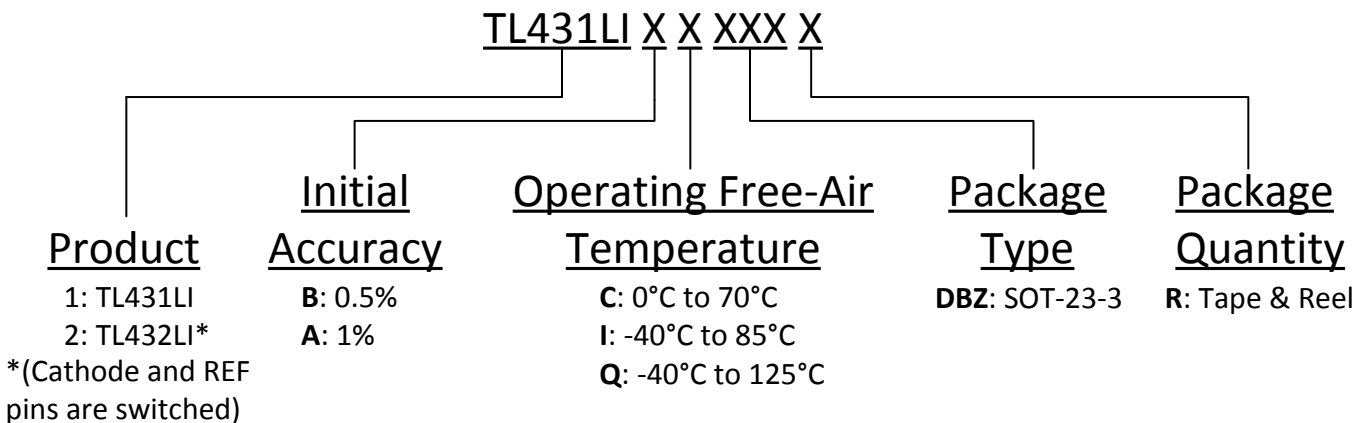

13.2.2 Related Documentation

For related documentation see the following:

- [Understanding Stability Boundary Conditions Charts in TL431, TL432 Data Sheet](#), SLVA482
- [Setting the Shunt Voltage on an Adjustable Shunt Regulator](#), SLVA445
- [Designing With the Improved TL431LI](#), SNOAA00

13.3 Receiving Notification of Documentation Updates

To receive notification of documentation updates, navigate to the device product folder on ti.com. In the upper right corner, click on *Alert me* to register and receive a weekly digest of any product information that has changed. For change details, review the revision history included in any revised document.

13.4 Community Resources

The following links connect to TI community resources. Linked contents are provided "AS IS" by the respective contributors. They do not constitute TI specifications and do not necessarily reflect TI's views; see TI's [Terms of Use](#).

TI E2E™ Online Community *TI's Engineer-to-Engineer (E2E) Community*. Created to foster collaboration among engineers. At e2e.ti.com, you can ask questions, share knowledge, explore ideas and help solve problems with fellow engineers.

Design Support *TI's Design Support* Quickly find helpful E2E forums along with design support tools and contact information for technical support.

13.5 Trademarks

E2E is a trademark of Texas Instruments.

13.6 Electrostatic Discharge Caution



This integrated circuit can be damaged by ESD. Texas Instruments recommends that all integrated circuits be handled with appropriate precautions. Failure to observe proper handling and installation procedures can cause damage.

ESD damage can range from subtle performance degradation to complete device failure. Precision integrated circuits may be more susceptible to damage because very small parametric changes could cause the device not to meet its published specifications.

13.7 Glossary

[SLYZ022](#) — *TI Glossary*.

This glossary lists and explains terms, acronyms, and definitions.

14 Mechanical, Packaging, and Orderable Information

The following pages include mechanical, packaging, and orderable information. This information is the most current data available for the designated devices. This data is subject to change without notice and revision of this document. For browser-based versions of this data sheet, refer to the left-hand navigation.

PACKAGING INFORMATION

Orderable Device	Status (1)	Package Type	Package Drawing	Pins	Package Qty	Eco Plan (2)	Lead finish/ Ball material (6)	MSL Peak Temp (3)	Op Temp (°C)	Device Marking (4/5)	Samples
TL431LIACDBZR	ACTIVE	SOT-23	DBZ	3	3000	RoHS & Green	NIPDAU SN	Level-1-260C-UNLIM	0 to 70	1TMP	Samples
TL431LIAIDBZR	ACTIVE	SOT-23	DBZ	3	3000	RoHS & Green	NIPDAU SN	Level-1-260C-UNLIM	-40 to 85	1TOP	Samples
TL431LIAQDBZR	ACTIVE	SOT-23	DBZ	3	3000	RoHS & Green	NIPDAU SN	Level-1-260C-UNLIM	-40 to 125	1BLP	Samples
TL431LIBCDBZR	ACTIVE	SOT-23	DBZ	3	3000	RoHS & Green	NIPDAU SN	Level-1-260C-UNLIM	0 to 70	1TNP	Samples
TL431LIBIDBZR	ACTIVE	SOT-23	DBZ	3	3000	RoHS & Green	NIPDAU SN	Level-1-260C-UNLIM	-40 to 85	1TPP	Samples
TL431LIBQDBZR	ACTIVE	SOT-23	DBZ	3	3000	RoHS & Green	NIPDAU SN	Level-1-260C-UNLIM	-40 to 125	1BMP	Samples
TL432LIACDBZR	ACTIVE	SOT-23	DBZ	3	3000	RoHS & Green	NIPDAU SN	Level-1-260C-UNLIM	0 to 70	1TQP	Samples
TL432LIAIDBZR	ACTIVE	SOT-23	DBZ	3	3000	RoHS & Green	NIPDAU SN	Level-1-260C-UNLIM	-40 to 85	1TSP	Samples
TL432LIAQDBZR	ACTIVE	SOT-23	DBZ	3	3000	RoHS & Green	NIPDAU SN	Level-1-260C-UNLIM	-40 to 125	1BNP	Samples
TL432LIBCDBZR	ACTIVE	SOT-23	DBZ	3	3000	RoHS & Green	NIPDAU SN	Level-1-260C-UNLIM	0 to 70	1TRP	Samples
TL432LIBIDBZR	ACTIVE	SOT-23	DBZ	3	3000	RoHS & Green	NIPDAU SN	Level-1-260C-UNLIM	-40 to 85	1TTP	Samples
TL432LIBQDBZR	ACTIVE	SOT-23	DBZ	3	3000	RoHS & Green	NIPDAU SN	Level-1-260C-UNLIM	-40 to 125	1BOP	Samples

(1) The marketing status values are defined as follows:

ACTIVE: Product device recommended for new designs.

LIFEBUY: TI has announced that the device will be discontinued, and a lifetime-buy period is in effect.

NRND: Not recommended for new designs. Device is in production to support existing customers, but TI does not recommend using this part in a new design.

PREVIEW: Device has been announced but is not in production. Samples may or may not be available.

OBSELETE: TI has discontinued the production of the device.

(2) **RoHS:** TI defines "RoHS" to mean semiconductor products that are compliant with the current EU RoHS requirements for all 10 RoHS substances, including the requirement that RoHS substance do not exceed 0.1% by weight in homogeneous materials. Where designed to be soldered at high temperatures, "RoHS" products are suitable for use in specified lead-free processes. TI may reference these types of products as "Pb-Free".

RoHS Exempt: TI defines "RoHS Exempt" to mean products that contain lead but are compliant with EU RoHS pursuant to a specific EU RoHS exemption.

Green: TI defines "Green" to mean the content of Chlorine (Cl) and Bromine (Br) based flame retardants meet JS709B low halogen requirements of <=1000ppm threshold. Antimony trioxide based flame retardants must also meet the <=1000ppm threshold requirement.

- (3) MSL, Peak Temp. - The Moisture Sensitivity Level rating according to the JEDEC industry standard classifications, and peak solder temperature.
- (4) There may be additional marking, which relates to the logo, the lot trace code information, or the environmental category on the device.
- (5) Multiple Device Markings will be inside parentheses. Only one Device Marking contained in parentheses and separated by a "-" will appear on a device. If a line is indented then it is a continuation of the previous line and the two combined represent the entire Device Marking for that device.
- (6) Lead finish/Ball material - Orderable Devices may have multiple material finish options. Finish options are separated by a vertical ruled line. Lead finish/Ball material values may wrap to two lines if the finish value exceeds the maximum column width.

Important Information and Disclaimer:The information provided on this page represents TI's knowledge and belief as of the date that it is provided. TI bases its knowledge and belief on information provided by third parties, and makes no representation or warranty as to the accuracy of such information. Efforts are underway to better integrate information from third parties. TI has taken and continues to take reasonable steps to provide representative and accurate information but may not have conducted destructive testing or chemical analysis on incoming materials and chemicals. TI and TI suppliers consider certain information to be proprietary, and thus CAS numbers and other limited information may not be available for release.

In no event shall TI's liability arising out of such information exceed the total purchase price of the TI part(s) at issue in this document sold by TI to Customer on an annual basis.

OTHER QUALIFIED VERSIONS OF TL431LI, TL432LI :

- Automotive: [TL431LI-Q1](#), [TL432LI-Q1](#)

NOTE: Qualified Version Definitions:

- Automotive - Q100 devices qualified for high-reliability automotive applications targeting zero defects

TAPE AND REEL INFORMATION



QUADRANT ASSIGNMENTS FOR PIN 1 ORIENTATION IN TAPE



*All dimensions are nominal

Device	Package Type	Package Drawing	Pins	SPQ	Reel Diameter (mm)	Reel Width W1 (mm)	A0 (mm)	B0 (mm)	K0 (mm)	P1 (mm)	W (mm)	Pin1 Quadrant
TL431LIACDBZR	SOT-23	DBZ	3	3000	178.0	9.2	3.15	2.77	1.22	4.0	8.0	Q3
TL431LIACDBZR	SOT-23	DBZ	3	3000	178.0	9.0	3.15	2.77	1.22	4.0	8.0	Q3
TL431LIAIDBZR	SOT-23	DBZ	3	3000	178.0	9.2	3.15	2.77	1.22	4.0	8.0	Q3
TL431LIAIDBZR	SOT-23	DBZ	3	3000	178.0	9.0	3.15	2.77	1.22	4.0	8.0	Q3
TL431LIAQDBZR	SOT-23	DBZ	3	3000	178.0	9.0	3.15	2.77	1.22	4.0	8.0	Q3
TL431LIAQDBZR	SOT-23	DBZ	3	3000	178.0	9.2	3.15	2.77	1.22	4.0	8.0	Q3
TL431LIBCDBZR	SOT-23	DBZ	3	3000	178.0	9.2	3.15	2.77	1.22	4.0	8.0	Q3
TL431LIBCDBZR	SOT-23	DBZ	3	3000	178.0	9.0	3.15	2.77	1.22	4.0	8.0	Q3
TL431LIBIDBZR	SOT-23	DBZ	3	3000	178.0	9.2	3.15	2.77	1.22	4.0	8.0	Q3
TL431LIBIDBZR	SOT-23	DBZ	3	3000	178.0	9.0	3.15	2.77	1.22	4.0	8.0	Q3
TL431LIBQDBZR	SOT-23	DBZ	3	3000	178.0	9.0	3.15	2.77	1.22	4.0	8.0	Q3
TL431LIBQDBZR	SOT-23	DBZ	3	3000	178.0	9.2	3.15	2.77	1.22	4.0	8.0	Q3
TL432LIACDBZR	SOT-23	DBZ	3	3000	178.0	9.0	3.15	2.77	1.22	4.0	8.0	Q3
TL432LIACDBZR	SOT-23	DBZ	3	3000	178.0	9.2	3.15	2.77	1.22	4.0	8.0	Q3
TL432LIAIDBZR	SOT-23	DBZ	3	3000	178.0	9.2	3.15	2.77	1.22	4.0	8.0	Q3
TL432LIAIDBZR	SOT-23	DBZ	3	3000	178.0	9.0	3.15	2.77	1.22	4.0	8.0	Q3
TL432LIAQDBZR	SOT-23	DBZ	3	3000	178.0	9.2	3.15	2.77	1.22	4.0	8.0	Q3
TL432LIAQDBZR	SOT-23	DBZ	3	3000	178.0	9.0	3.15	2.77	1.22	4.0	8.0	Q3

Device	Package Type	Package Drawing	Pins	SPQ	Reel Diameter (mm)	Reel Width W1 (mm)	A0 (mm)	B0 (mm)	K0 (mm)	P1 (mm)	W (mm)	Pin1 Quadrant
TL432LBCDBZR	SOT-23	DBZ	3	3000	178.0	9.2	3.15	2.77	1.22	4.0	8.0	Q3
TL432LBCDBZR	SOT-23	DBZ	3	3000	178.0	9.0	3.15	2.77	1.22	4.0	8.0	Q3
TL432LIBIDBZR	SOT-23	DBZ	3	3000	178.0	9.0	3.15	2.77	1.22	4.0	8.0	Q3
TL432LIBIDBZR	SOT-23	DBZ	3	3000	178.0	9.2	3.15	2.77	1.22	4.0	8.0	Q3
TL432LIBQDBZR	SOT-23	DBZ	3	3000	178.0	9.0	3.15	2.77	1.22	4.0	8.0	Q3
TL432LIBQDBZR	SOT-23	DBZ	3	3000	178.0	9.2	3.15	2.77	1.22	4.0	8.0	Q3

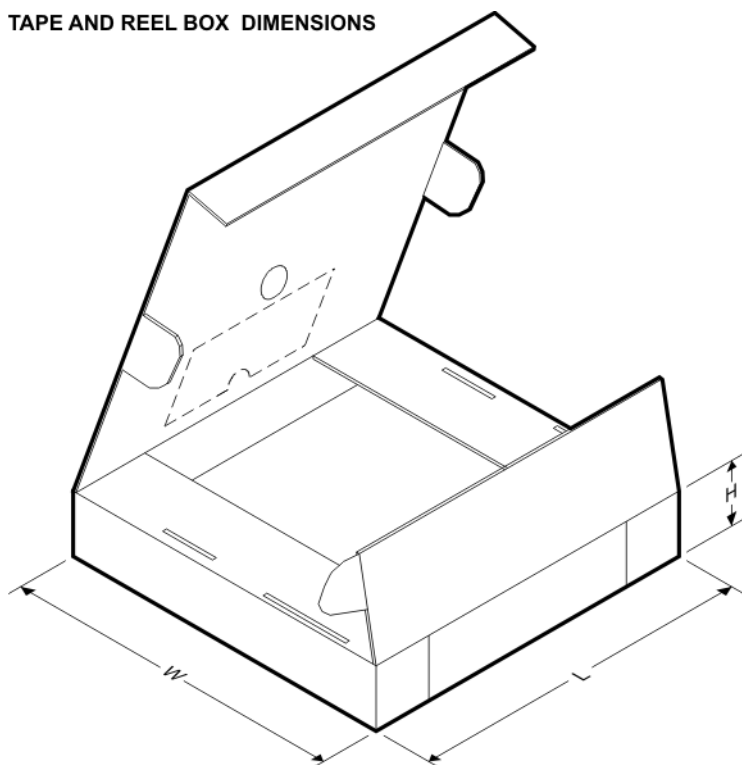
TAPE AND REEL BOX DIMENSIONS

*All dimensions are nominal

Device	Package Type	Package Drawing	Pins	SPQ	Length (mm)	Width (mm)	Height (mm)
TL431LIACDBZR	SOT-23	DBZ	3	3000	180.0	180.0	18.0
TL431LIACDBZR	SOT-23	DBZ	3	3000	180.0	180.0	18.0
TL431LIAIDBZR	SOT-23	DBZ	3	3000	180.0	180.0	18.0
TL431LIAIDBZR	SOT-23	DBZ	3	3000	180.0	180.0	18.0
TL431LIAQDBZR	SOT-23	DBZ	3	3000	180.0	180.0	18.0
TL431LIAQDBZR	SOT-23	DBZ	3	3000	180.0	180.0	18.0
TL431LBCDBZR	SOT-23	DBZ	3	3000	180.0	180.0	18.0
TL431LBCDBZR	SOT-23	DBZ	3	3000	180.0	180.0	18.0
TL431LIBIDBZR	SOT-23	DBZ	3	3000	180.0	180.0	18.0
TL431LIBIDBZR	SOT-23	DBZ	3	3000	180.0	180.0	18.0
TL431LIBQDBZR	SOT-23	DBZ	3	3000	180.0	180.0	18.0

Device	Package Type	Package Drawing	Pins	SPQ	Length (mm)	Width (mm)	Height (mm)
TL431LIBQDBZR	SOT-23	DBZ	3	3000	180.0	180.0	18.0
TL432LIACDBZR	SOT-23	DBZ	3	3000	180.0	180.0	18.0
TL432LIACDBZR	SOT-23	DBZ	3	3000	180.0	180.0	18.0
TL432LIAIDBZR	SOT-23	DBZ	3	3000	180.0	180.0	18.0
TL432LIAIDBZR	SOT-23	DBZ	3	3000	180.0	180.0	18.0
TL432LIAQDBZR	SOT-23	DBZ	3	3000	180.0	180.0	18.0
TL432LIAQDBZR	SOT-23	DBZ	3	3000	180.0	180.0	18.0
TL432LIBCDBZR	SOT-23	DBZ	3	3000	180.0	180.0	18.0
TL432LIBCDBZR	SOT-23	DBZ	3	3000	180.0	180.0	18.0
TL432LIBIDBZR	SOT-23	DBZ	3	3000	180.0	180.0	18.0
TL432LIBIDBZR	SOT-23	DBZ	3	3000	180.0	180.0	18.0
TL432LIBQDBZR	SOT-23	DBZ	3	3000	180.0	180.0	18.0
TL432LIBQDBZR	SOT-23	DBZ	3	3000	180.0	180.0	18.0

DBZ0003A



PACKAGE OUTLINE

SOT-23 - 1.12 mm max height

SMALL OUTLINE TRANSISTOR

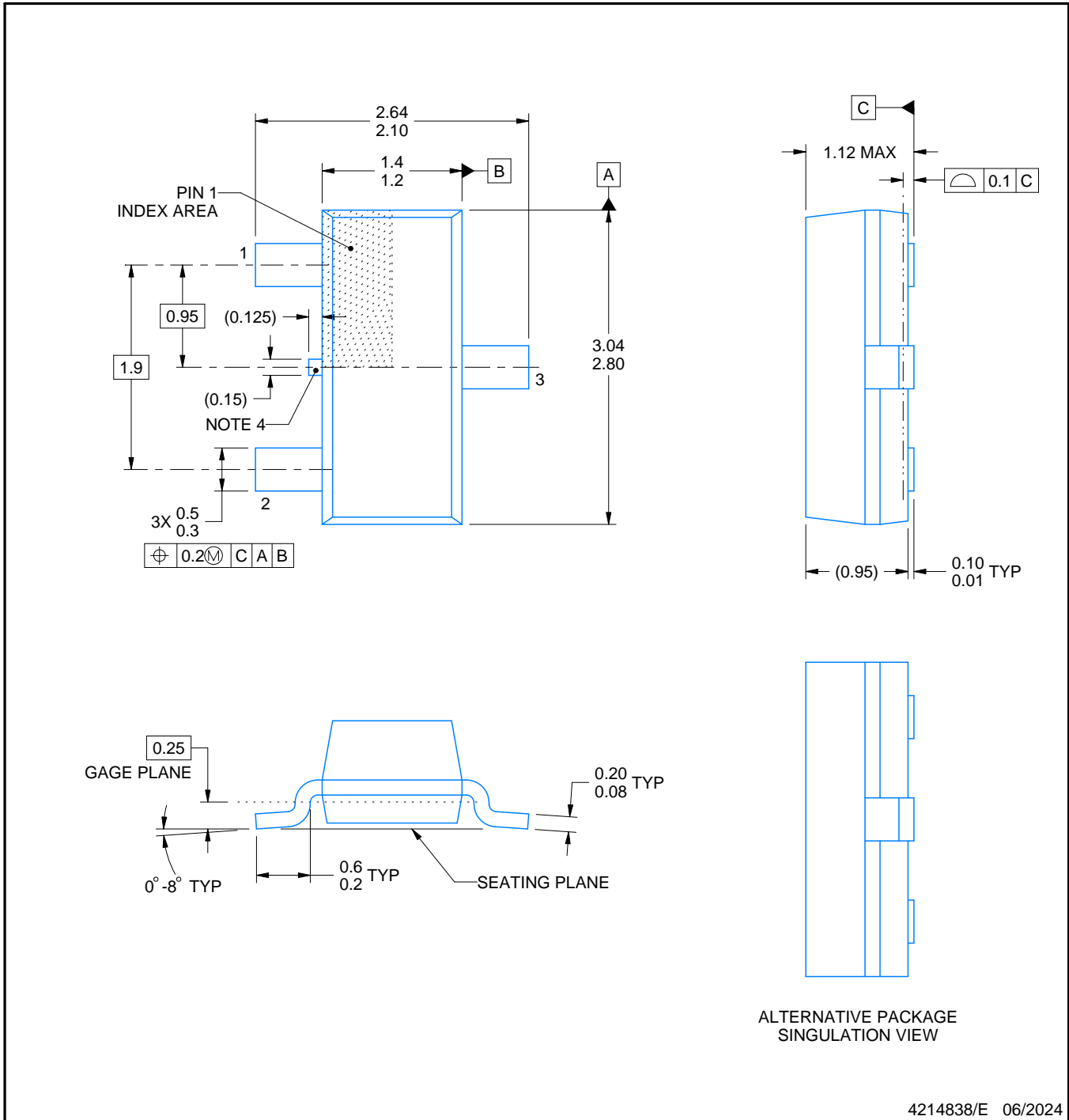

4214838/E 06/2024

NOTES:

1. All linear dimensions are in millimeters. Any dimensions in parenthesis are for reference only. Dimensioning and tolerancing per ASME Y14.5M.
2. This drawing is subject to change without notice.
3. Reference JEDEC registration TO-236, except minimum foot length.
4. Support pin may differ or may not be present.
5. Body dimensions do not include mold flash, protrusions, or gate burrs. Mold flash, protrusions, or gate burrs shall not exceed 0.25mm per side

EXAMPLE BOARD LAYOUT

DBZ0003A

SOT-23 - 1.12 mm max height

SMALL OUTLINE TRANSISTOR

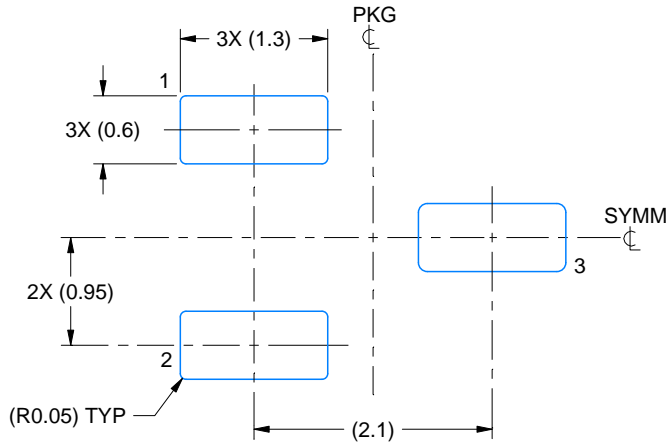

LAND PATTERN EXAMPLE
SCALE:15X

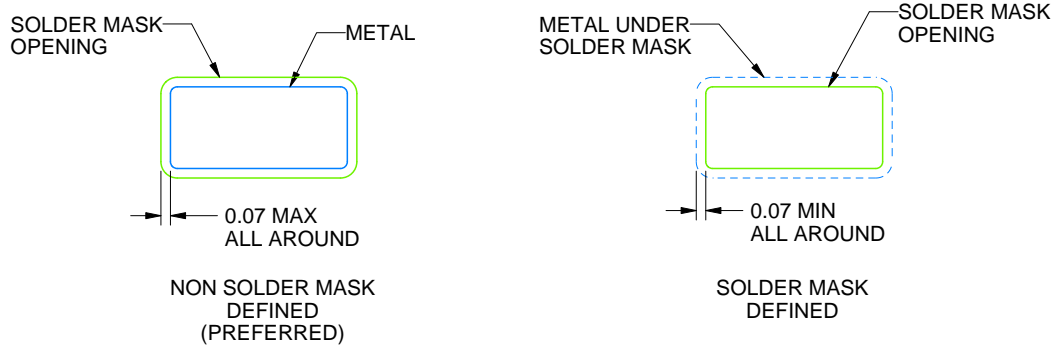

SOLDER MASK DETAILS

4214838/E 06/2024

NOTES: (continued)

5. Publication IPC-7351 may have alternate designs.
6. Solder mask tolerances between and around signal pads can vary based on board fabrication site.

EXAMPLE STENCIL DESIGN

DBZ0003A

SOT-23 - 1.12 mm max height

SMALL OUTLINE TRANSISTOR

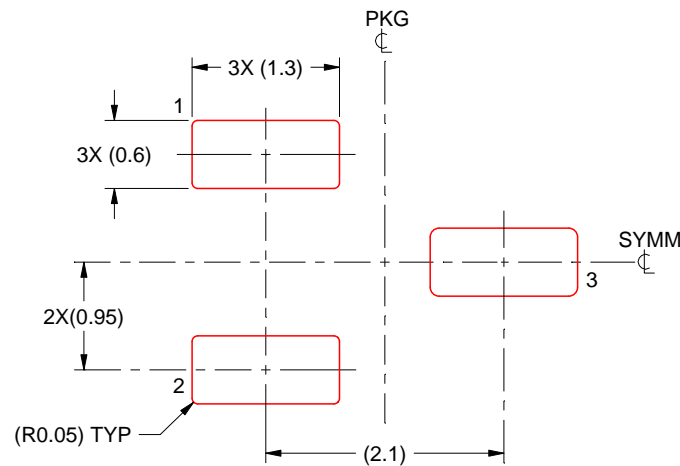

SOLDER PASTE EXAMPLE
BASED ON 0.125 THICK STENCIL
SCALE:15X

4214838/E 06/2024

NOTES: (continued)

7. Laser cutting apertures with trapezoidal walls and rounded corners may offer better paste release. IPC-7525 may have alternate design recommendations.
8. Board assembly site may have different recommendations for stencil design.

IMPORTANT NOTICE AND DISCLAIMER

TI PROVIDES TECHNICAL AND RELIABILITY DATA (INCLUDING DATA SHEETS), DESIGN RESOURCES (INCLUDING REFERENCE DESIGNS), APPLICATION OR OTHER DESIGN ADVICE, WEB TOOLS, SAFETY INFORMATION, AND OTHER RESOURCES "AS IS" AND WITH ALL FAULTS, AND DISCLAIMS ALL WARRANTIES, EXPRESS AND IMPLIED, INCLUDING WITHOUT LIMITATION ANY IMPLIED WARRANTIES OF MERCHANTABILITY, FITNESS FOR A PARTICULAR PURPOSE OR NON-INFRINGEMENT OF THIRD PARTY INTELLECTUAL PROPERTY RIGHTS.

These resources are intended for skilled developers designing with TI products. You are solely responsible for (1) selecting the appropriate TI products for your application, (2) designing, validating and testing your application, and (3) ensuring your application meets applicable standards, and any other safety, security, regulatory or other requirements.

These resources are subject to change without notice. TI grants you permission to use these resources only for development of an application that uses the TI products described in the resource. Other reproduction and display of these resources is prohibited. No license is granted to any other TI intellectual property right or to any third party intellectual property right. TI disclaims responsibility for, and you will fully indemnify TI and its representatives against, any claims, damages, costs, losses, and liabilities arising out of your use of these resources.

TI's products are provided subject to [TI's Terms of Sale](#) or other applicable terms available either on [ti.com](https://www.ti.com) or provided in conjunction with such TI products. TI's provision of these resources does not expand or otherwise alter TI's applicable warranties or warranty disclaimers for TI products.

TI objects to and rejects any additional or different terms you may have proposed.

Mailing Address: Texas Instruments, Post Office Box 655303, Dallas, Texas 75265
Copyright © 2024, Texas Instruments Incorporated

Looking for pricing, stock, or lifecycle information?

Click below to explore more details on WIN SOURCE:

 [View CC0603ZRY5V6BB225 on WIN SOURCE](#)

 [Yageo Information](#)

Optimize Your Supply Chain with WIN SOURCE Solutions

-  Global Sourcing Solution
-  Obsolete Management
-  Cost Control Management
-  Shortage Management
-  Alternative Solution
-  Excess Inventory Management