



THE DATASHEET OF CAS-220TB



SLIDE SWITCHES (SMD)



RoHS compliant

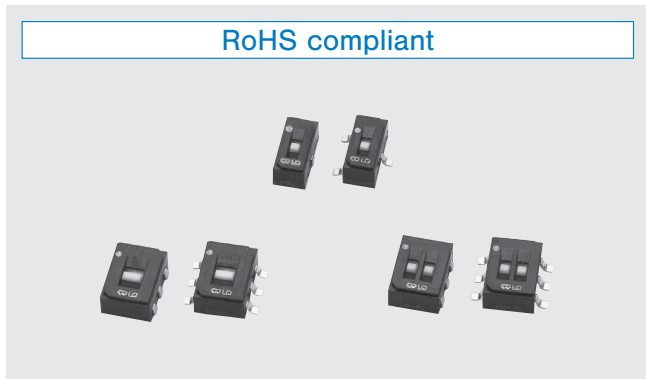

INTERNAL STRUCTURE

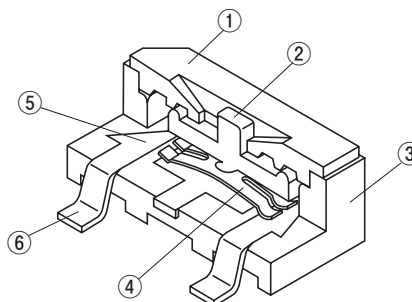

Part name	Material
① Cover	Polyphenylenesulfide
② Slider	Polyamide
③ Housing	Polyphenylenesulfide
④ Slider contact	Copper alloy, Gold-plated
⑤ Fixed contact	
⑥ Terminal pin	

FEATURES

- RoHS compliant
- Compatible with most automatic pick & place machinery
- Compact and space saving SMD type
- Excellent contact stability by twin Gold-plated contact
- Low profile design of 2.5 mm
- Resin material is UL Recognized 94V-0

PART NUMBER DESIGNATION

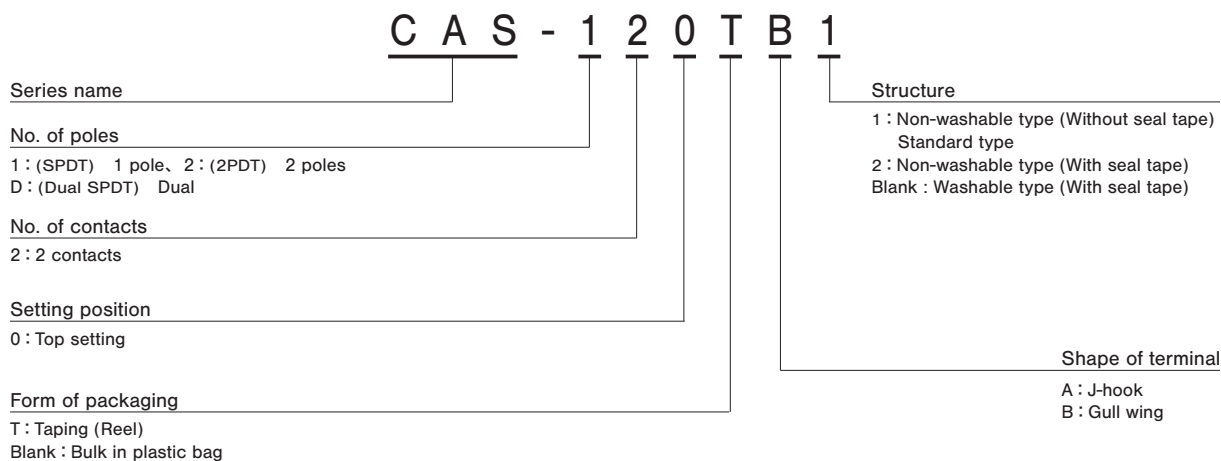

SPDT : Single Pole Double Throw 2PDT : Two Poles Double Throw

※ Please refer to the LIST OF PART NUMBERS when placing orders.

CAS

SLIDE SWITCHES (SMD)

LIST OF PART NUMBERS

No. of poles	No. of contacts	Setting position	Form of packaging	Non-washable type (Without seal tape)		Non-washable type (With seal tape)		Packaging quantity
				A (J-hook)	B (Gull wing)	A (J-hook)	B (Gull wing)	
1	2	Top setting	Taping	CAS-120TA1	CAS-120TB1	CAS-120TA2	CAS-120TB2	1000pcs./reel
			Plastic bag	CAS-120A1	CAS-120B1	CAS-120A2	CAS-120B2	100pcs./pack
2			Taping	CAS-220TA1	CAS-220TB1	CAS-220TA2	CAS-220TB2	1000pcs./reel
			Plastic bag	CAS-220A1	CAS-220B1	CAS-220A2	CAS-220B2	100pcs./pack
Dual			Taping	CAS-D20TA1	CAS-D20TB1	CAS-D20TA2	CAS-D20TB2	1000pcs./reel
			Plastic bag	CAS-D20A1	CAS-D20B1	CAS-D20A2	CAS-D20B2	100pcs./pack

No. of poles	No. of contacts	Setting position	Form of packaging	Washable type (With seal tape)		Packaging quantity
				A (J-hook)	B (Gull wing)	
1	2	Top setting	Taping	CAS-120TA	CAS-120TB	1000pcs./reel
			Plastic bag	CAS-120A	CAS-120B	100pcs./pack
2			Taping	CAS-220TA	CAS-220TB	1000pcs./reel
			Plastic bag	CAS-220A	CAS-220B	100pcs./pack
Dual			Taping	CAS-D20TA	CAS-D20TB	1000pcs./reel
			Plastic bag	CAS-D20A	CAS-D20B	100pcs./pack

※ Verify the above part numbers when placing orders.
Taping version can be supplied only in reel unit.

STANDARD SPECIFICATIONS

Operating temp. range	- 40 ~ 85 °C
Storage temp. range	
Sealing	Washable type available with seal tape
Net weight	Approx. 0.05g (CAS-120) Approx. 0.08g (CAS-220/D20)

ELECTRICAL CHARACTERISTICS

Contact rating Non-switching Switching Minimum	DC50 V, 100 mA DC6 V, 100 mA / DC24 V, 25 mA DC20 mV , 1 μA
Contact resistance	50 mΩ maximum
Insulation resistance	1000 MΩ (DC100 V) minimum
Dielectric strength	AC500 V, 60 s

MECHANICAL CHARACTERISTICS

Operating force	0.5 ~ 5 N {0.05 ~ 0.51 kgf}
Stop strength	10 N {1.02 kgf}, 60 s
Solderability	245 ± 3 °C, 2 ~ 3 s
Soldering heat	Reflow : 255 °C (Peak temperature) (Please refer to the profile below)
	Manual soldering : 350 ± 10 °C, 3 ~ 4 s
Shear (Adhesion)	5 N {0.51 kgf} 10 s
Substrate bending	Width 90 mm, bend 3 mm, 5 s, 1 time
Pull-off strength	5 N {0.51 kgf} 10 s

{ } :Reference only

ENVIRONMENTAL CHARACTERISTICS

Vibration	(Amplitude) 1.5 mm or (Acceleration) 98 m/s ² , 10-500 Hz, 3 directions for 10 cycles each
Shock	490 m/s ² , 11 ms 6 directions for 3 times each
Load life	Continuous load 2000 cycles, DC6 ± 0.5 V, 100 ± 10 mA
Humidity	-10 ~ 65 °C, Relative humidity 0 ~ 96 %, 24 h for 10 cycles
High temp. exposure	85 °C, 96 h
Low temp. exposure	-40 °C, 96 h
Thermal shock	-40 (0.5 h) ~ 85 °C (0.5 h), 5 cycles

〈Reflow profile for soldering heat evaluation〉

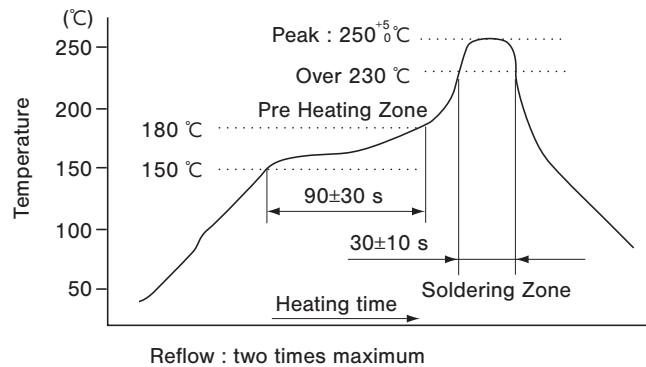

CAS

SLIDE SWITCHES (SMD)

OUTLINE DIMENSIONS

Unless otherwise specified, tolerance : ± 0.3 (Unit : mm)

CAS-120A1

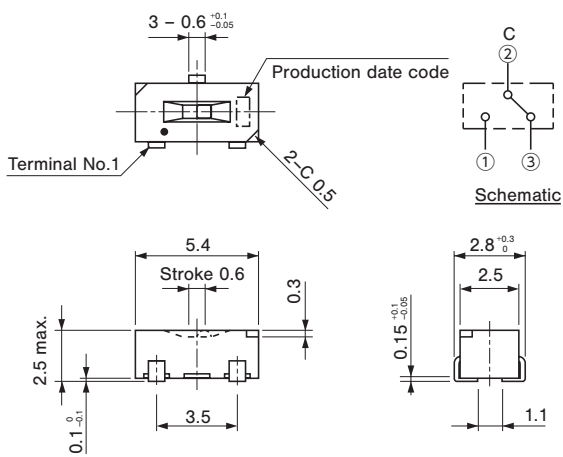

CAS-120B1

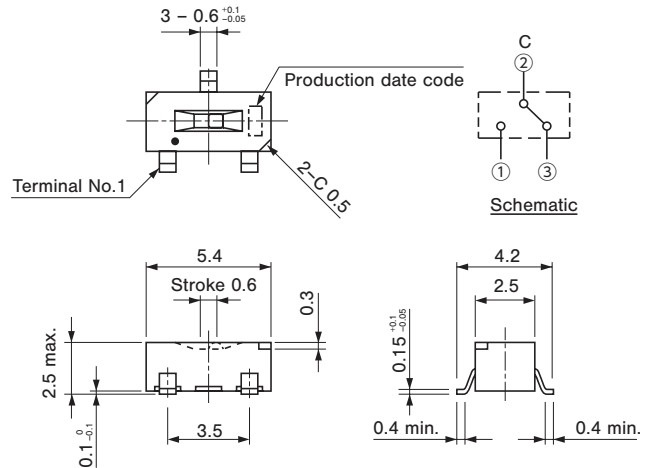

CAS-220A1

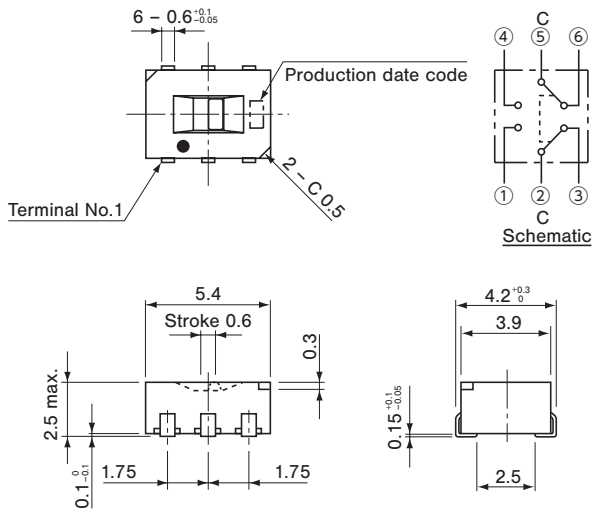

CAS-220B1

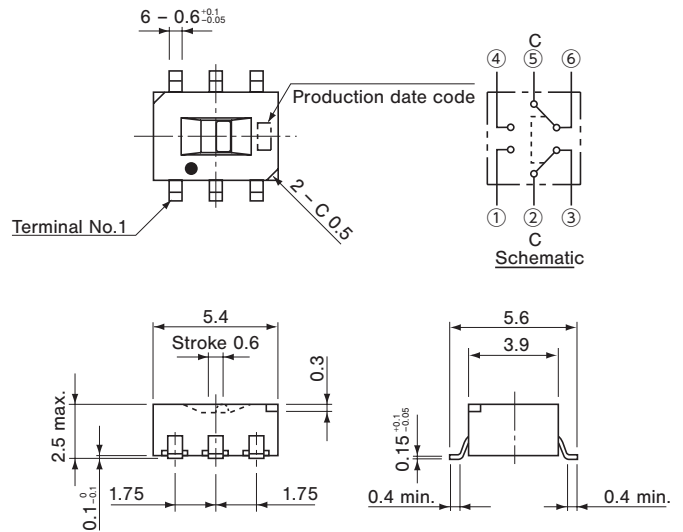

CAS-D20A1

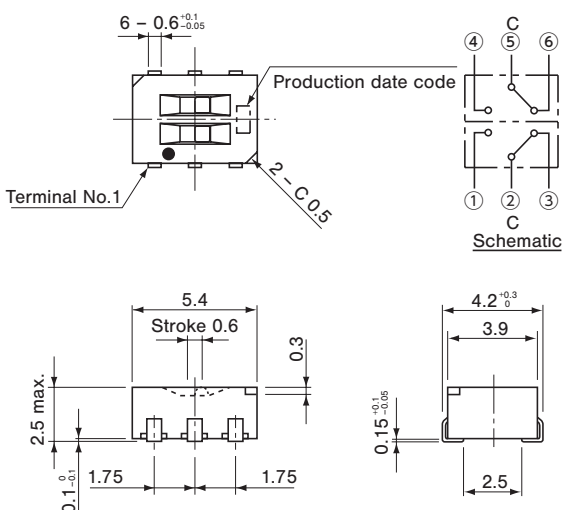

CAS-D20B1

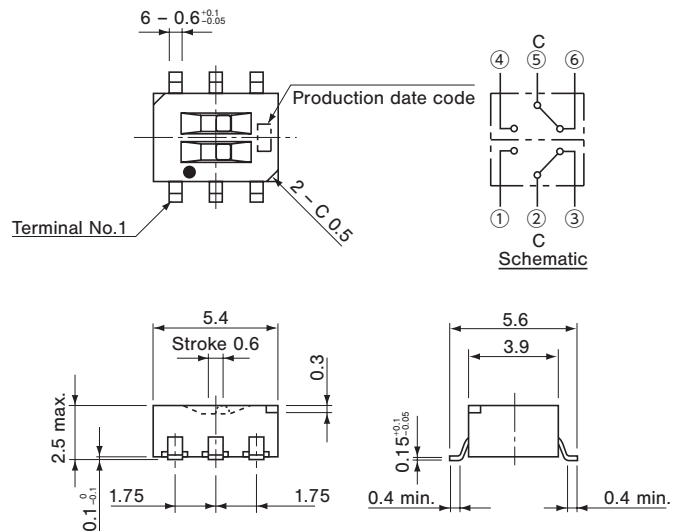

RECOMMENDED P.C.B. PAD OUTLINE DIMENSIONS

● CAS-120

(Unit : mm)

A Type

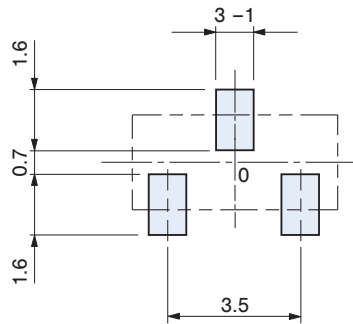

B Type

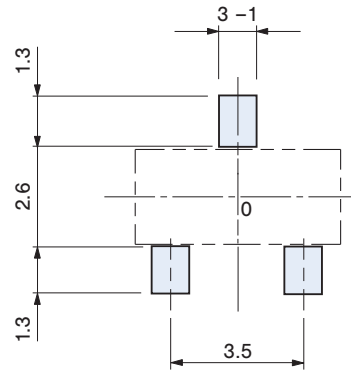

● CAS-220 • D20

A Type

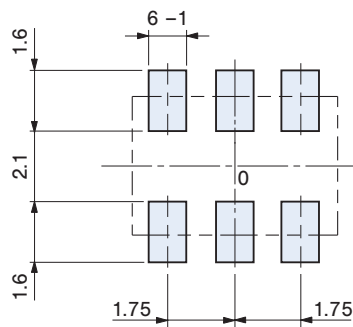

B Type

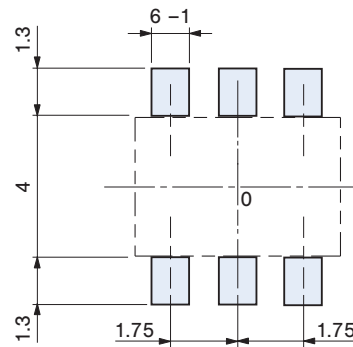

Note) The zero point is the center of mounting.

CAS

SLIDE SWITCHES (SMD)

PACKAGING SPECIFICATIONS

<Taping packaging specifications>

- Taping version is packaged in 1000 pcs. per reel.
Orders will be accepted for units of 1000 pcs., i.e., 1000, 2000, 3000 pcs., etc.
- Taping version is boxed with two reels (2000 pcs.).

Maximum number of consecutive missing pieces=2
Leader length and reel dimension are shown in the diagrams below:

● Embossed tape dimensions

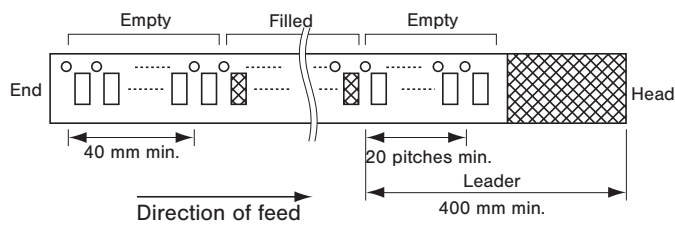

● Reel dimensions

(Unit: mm)
(Conforms to JIS C 0806-3)

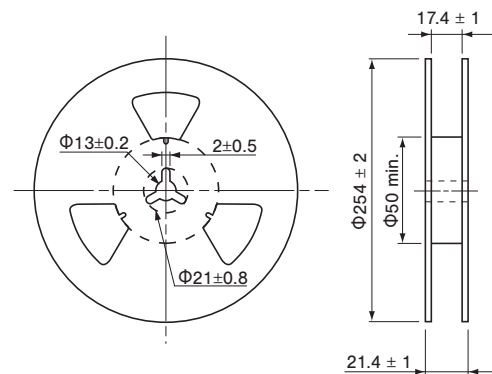

● CAS-120TA, TB

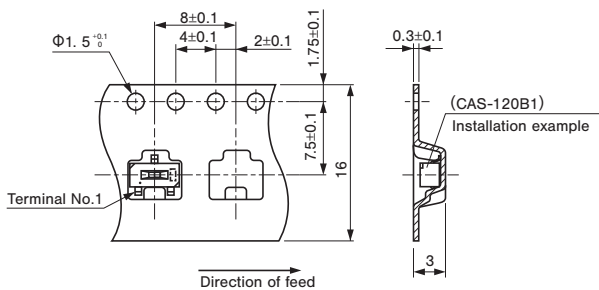

● CAS-220TA, TB • D20TA, TB

(Unit: mm)

(Conforms to JIS C 0806-3)

(In accordance with EIAJ ET-7200A)

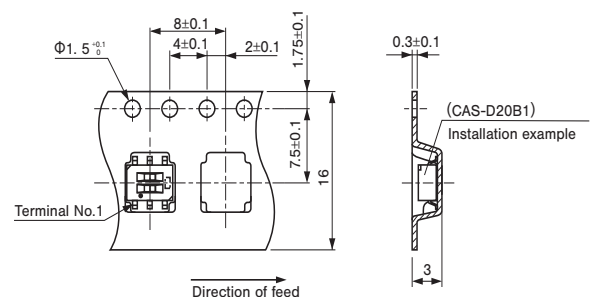

<Bulk pack specifications>

- Boxing of bulk pack in a plastic bag is performed with 100 pcs. (standard 500 pcs.) per box.

Looking for pricing, stock, or lifecycle information?

Click below to explore more details on WIN SOURCE:

- ⊖ [View CAS-220TB on WIN SOURCE](#)
- ⊖ [Nidec Copal Electronics Information](#)

Optimize Your Supply Chain with WIN SOURCE Solutions

- ✓ Global Sourcing Solution
- ✓ Obsolete Management
- ✓ Cost Control Management
- ✓ Shortage Management
- ✓ Alternative Solution
- ✓ Excess Inventory Management