



**THE DATASHEET OF
C3216X5R0J336M130AC**



8-Bit

XC87xCLM

8-Bit Single-Chip Microcontroller

Data Sheet

V1.5 2011-03

Microcontrollers

Edition 2011-03

**Published by
Infineon Technologies AG
81726 Munich, Germany**

**© 2011 Infineon Technologies AG
All Rights Reserved.**

Legal Disclaimer

The information given in this document shall in no event be regarded as a guarantee of conditions or characteristics. With respect to any examples or hints given herein, any typical values stated herein and/or any information regarding the application of the device, Infineon Technologies hereby disclaims any and all warranties and liabilities of any kind, including without limitation, warranties of non-infringement of intellectual property rights of any third party.

Information

For further information on technology, delivery terms and conditions and prices, please contact the nearest Infineon Technologies Office (www.infineon.com).

Warnings

Due to technical requirements, components may contain dangerous substances. For information on the types in question, please contact the nearest Infineon Technologies Office.

Infineon Technologies components may be used in life-support devices or systems only with the express written approval of Infineon Technologies, if a failure of such components can reasonably be expected to cause the failure of that life-support device or system or to affect the safety or effectiveness of that device or system. Life support devices or systems are intended to be implanted in the human body or to support and/or maintain and sustain and/or protect human life. If they fail, it is reasonable to assume that the health of the user or other persons may be endangered.

8-Bit

XC87xCLM

8-Bit Single-Chip Microcontroller

Data Sheet

V1.5 2011-03

Microcontrollers

XC87x Data Sheet**Revision History: V1.5 2011-03**

Previous Versions: V1.4

Page	Subjects (major changes since last revision)
------	--

Changes from V1.4 2010-08 to V1.5 2011-03

Page 3	A new variant, SAF-XC874CM-13FVA 5V, has been added in Table 2.
---------------	---

We Listen to Your Comments

Any information within this document that you feel is wrong, unclear or missing at all? Your feedback will help us to continuously improve the quality of this document. Please send your proposal (including a reference to this document) to:

mcdocu.comments@infineon.com

Table of Contents

1	Summary of Features	1
2	General Device Information	6
2.1	Block Diagram	6
2.2	Logic Symbol	7
2.3	Pin Configuration	8
2.4	Pin Definitions and Functions	10
3	Functional Description	21
3.1	Processor Architecture	21
3.2	Memory Organization	22
3.2.1	Memory Protection Strategy	24
3.2.1.1	Flash Memory Protection	24
3.2.2	Special Function Register	26
3.2.2.1	Address Extension by Mapping	26
3.2.2.2	Address Extension by Paging	28
3.2.3	Bit Protection Scheme	32
3.2.3.1	Password Register	33
3.2.4	XC87x Register Overview	34
3.2.4.1	CPU Registers	34
3.2.4.2	MDU Registers	35
3.2.4.3	CORDIC Registers	36
3.2.4.4	System Control Registers	37
3.2.4.5	WDT Registers	40
3.2.4.6	Port Registers	40
3.2.4.7	ADC Registers	43
3.2.4.8	Timer 2 Compare/Capture Unit Registers	47
3.2.4.9	Timer 21 Registers	49
3.2.4.10	CCU6 Registers	50
3.2.4.11	UART1 Registers	54
3.2.4.12	SSC Registers	54
3.2.4.13	MultiCAN Registers	55
3.2.4.14	OCDS Registers	55
3.2.4.15	Flash Registers	57
3.3	Flash Memory	58
3.3.1	Flash Bank Pagination	60
3.4	Interrupt System	61
3.4.1	Interrupt Source	61
3.4.2	Interrupt Source and Vector	67
3.4.3	Interrupt Priority	69
3.5	Parallel Ports	70
3.6	Power Supply System with Embedded Voltage Regulator	72

Table of Contents

3.7	Reset Control	73
3.7.1	Module Reset Behavior	73
3.7.2	Bootling Scheme	74
3.8	Clock Generation Unit	75
3.8.1	Recommended External Oscillator Circuits	77
3.8.2	Clock Management	79
3.9	Power Saving Modes	82
3.10	Watchdog Timer	83
3.11	Multiplication/Division Unit	86
3.12	CORDIC Coprocessor	87
3.13	UART and UART1	88
3.13.1	Baud-Rate Generator	88
3.13.2	Baud Rate Generation using Timer 1	91
3.14	Normal Divider Mode (8-bit Auto-reload Timer)	91
3.15	LIN Protocol	92
3.15.1	LIN Header Transmission	92
3.16	High-Speed Synchronous Serial Interface	94
3.17	Timer 0 and Timer 1	96
3.18	Timer 2 and Timer 21	97
3.19	Timer 2 Capture/Compare Unit	98
3.20	Capture/Compare Unit 6	99
3.21	Controller Area Network (MultiCAN)	101
3.22	Analog-to-Digital Converter	103
3.22.1	ADC Clocking Scheme	103
3.22.2	ADC Conversion Sequence	104
3.23	On-Chip Debug Support	106
3.23.1	JTAG ID Register	107
3.24	Chip Identification Number	108
4	Electrical Parameters	108
4.1	General Parameters	108
4.1.1	Parameter Interpretation	108
4.1.2	Absolute Maximum Rating	109
4.1.3	Operating Conditions	110
4.2	DC Parameters	111
4.2.1	Input/Output Characteristics	111
4.2.2	Supply Threshold Characteristics	114
4.2.3	ADC Characteristics	115
4.2.3.1	ADC Conversion Timing	117
4.2.4	Power Supply Current	118
4.3	AC Parameters	122
4.3.1	Testing Waveforms	122
4.3.2	Output Rise/Fall Times	123

Table of Contents

4.3.3	Power-on Reset and PLL Timing	124
4.3.4	On-Chip Oscillator Characteristics	125
4.3.5	External Data Memory Characteristics	126
4.3.6	External Clock Drive XTAL1	128
4.3.7	JTAG Timing	129
4.3.8	SSC Master Mode Timing	131
5	Package and Quality Declaration	133
5.1	Package Parameters	133
5.2	Package Outline	134
5.3	Quality Declaration	136

1 Summary of Features

The XC87x has the following features:

- High-performance XC800 Core
 - compatible with standard 8051 processor
 - two clocks per machine cycle architecture (for memory access without wait state)
 - two data pointers
- On-chip memory
 - 8 Kbytes of Boot ROM
 - 256 bytes of RAM
 - 3 Kbytes of XRAM
 - 64/52 Kbytes of Flash;
 (includes memory protection strategy)
- I/O port supply at 3.3 V or 5.0 V and core logic supply at 2.5 V (generated by embedded voltage regulator)

(more features on next page)



Figure 1 XC87x Functional Units

Summary of Features

Features: (continued)

- Power-on reset generation
- Brownout detection for core logic supply
- On-chip OSC and PLL for clock generation
 - Loss-of-Clock detection
- Power saving modes
 - slow-down mode
 - idle mode
 - power-down mode with wake-up capability via RXD or EXINT0¹⁾
 - clock gating control to each peripheral
- Programmable 16-bit Watchdog Timer (WDT)
- Five ports
 - Up to 40 pins as digital I/O
 - 8 dedicated analog inputs used as A/D converter input
- 8-channel, 10-bit ADC
- Four 16-bit timers
 - Timer 0 and Timer 1 (T0 and T1)
 - Timer 2 and Timer 21 (T2 and T21)
- Multiplication/Division Unit for arithmetic operations (MDU)
- CORDIC Coprocessor for computation of trigonometric, hyperbolic and linear functions
- MultiCAN with 2 nodes, 32 message objects
- Two Capture/compare units
 - Capture/compare unit 6 for PWM signal generation (CCU6)
 - Timer 2 Capture/compare unit for various digital signal generation (T2CCU)
- Two full-duplex serial interfaces (UART and UART1)
- Synchronous serial channel (SSC)
- On-chip debug support
 - 1 Kbyte of monitor ROM (part of the 8-Kbyte Boot ROM)
 - 64 bytes of monitor RAM
- Packages:
 - PG-LQFP-64
 - PG-VQFN-48
- Temperature range T_A :
 - SAF (-40 to 85 °C)
 - SAX (-40 to 105 °C)
 - SAK (-40 to 125 °C)

1) SAK product variant does not support power-down mode.

Summary of Features
XC87x Variant Devices

The XC87x product family features devices with different configurations, program memory sizes, package options, power supply voltage, temperature and quality profiles (Automotive or Industrial), to offer cost-effective solutions for different application requirements.

The list of XC87x device configurations are summarized in [Table 1](#). 2 types of packages are available :

- PG-LQFP-64, which is denoted by XC878 and;
- PG-VQFN-48, which is denoted by XC874

Table 1 Device Configuration

Device Name	CAN Module	LIN BSL Support	MDU Module
XC87x	No	No	No
XC87xM	No	No	Yes
XC87xCM	Yes	No	Yes
XC87xLM	No	Yes	Yes
XC87xCLM	Yes	Yes	Yes

From these 5 different combinations of configuration, each are further made available in many sales types, which are grouped according to device type, program memory sizes, power supply voltage, temperature and quality profiles (Automotive or Industrial), as shown in [Table 2](#).

Table 2 Device Profile

Sales Type	Device Type	Program Memory (Kbytes)	Power Supply (V)	Temperature (°C)	Quality Profile
SAF-XC878-13FFI 5V	Flash	52	5.0	-40 to 85	Industrial
SAF-XC878M-13FFI 5V	Flash	52	5.0	-40 to 85	Industrial
SAF-XC878CM-13FFI 5V	Flash	52	5.0	-40 to 85	Industrial
SAF-XC878-16FFI 5V	Flash	64	5.0	-40 to 85	Industrial
SAF-XC878M-16FFI 5V	Flash	64	5.0	-40 to 85	Industrial
SAF-XC878CM-16FFI 5V	Flash	64	5.0	-40 to 85	Industrial
SAF-XC878-13FFI 3V3	Flash	52	3.3	-40 to 85	Industrial
SAF-XC878M-13FFI 3V3	Flash	52	3.3	-40 to 85	Industrial

Summary of Features
Table 2 Device Profile (cont'd)

Sales Type	Device Type	Program Memory (Kbytes)	Power Supply (V)	Temperature (°C)	Quality Profile
SAF-XC878CM-13FFI 3V3	Flash	52	3.3	-40 to 85	Industrial
SAF-XC878-16FFI 3V3	Flash	64	3.3	-40 to 85	Industrial
SAF-XC878M-16FFI 3V3	Flash	64	3.3	-40 to 85	Industrial
SAF-XC878CM-16FFI 3V3	Flash	64	3.3	-40 to 85	Industrial
SAF-XC878-13FFA 5V	Flash	52	5.0	-40 to 85	Automotive
SAF-XC878CM-13FFA 5V	Flash	52	5.0	-40 to 85	Automotive
SAF-XC878LM-13FFA 5V	Flash	52	5.0	-40 to 85	Automotive
SAF-XC878CLM-13FFA 5V	Flash	52	5.0	-40 to 85	Automotive
SAF-XC878-16FFA 5V	Flash	64	5.0	-40 to 85	Automotive
SAF-XC878CM-16FFA 5V	Flash	64	5.0	-40 to 85	Automotive
SAF-XC878LM-16FFA 5V	Flash	64	5.0	-40 to 85	Automotive
SAF-XC878CLM-16FFA 5V	Flash	64	5.0	-40 to 85	Automotive
SAX-XC878-13FFA 5V	Flash	52	5.0	-40 to 105	Automotive
SAX-XC878CM-13FFA 5V	Flash	52	5.0	-40 to 105	Automotive
SAX-XC878LM-13FFA 5V	Flash	52	5.0	-40 to 105	Automotive
SAX-XC878CLM-13FFA 5V	Flash	52	5.0	-40 to 105	Automotive
SAX-XC878-16FFA 5V	Flash	64	5.0	-40 to 105	Automotive
SAX-XC878CM-16FFA 5V	Flash	64	5.0	-40 to 105	Automotive
SAX-XC878LM-16FFA 5V	Flash	64	5.0	-40 to 105	Automotive
SAX-XC878CLM-16FFA 5V	Flash	64	5.0	-40 to 105	Automotive
SAK-XC878-13FFA 5V	Flash	52	5.0	-40 to 125	Automotive
SAK-XC878CM-13FFA 5V	Flash	52	5.0	-40 to 125	Automotive
SAK-XC878LM-13FFA 5V	Flash	52	5.0	-40 to 125	Automotive
SAK-XC878CLM-13FFA 5V	Flash	52	5.0	-40 to 125	Automotive
SAK-XC878-16FFA 5V	Flash	64	5.0	-40 to 125	Automotive
SAK-XC878CM-16FFA 5V	Flash	64	5.0	-40 to 125	Automotive
SAK-XC878LM-16FFA 5V	Flash	64	5.0	-40 to 125	Automotive
SAK-XC878CLM-16FFA 5V	Flash	64	5.0	-40 to 125	Automotive
SAF-XC874LM-16FVA 5V	Flash	64	5.0	-40 to 85	Automotive

Summary of Features
Table 2 Device Profile (cont'd)

Sales Type	Device Type	Program Memory (Kbytes)	Power Supply (V)	Temperature (°C)	Quality Profile
SAF-XC874CM-16FVA 5V	Flash	64	5.0	-40 to 85	Automotive
SAF-XC874CM-13FVA 5V	Flash	52	5.0	-40 to 85	Automotive
SAK-XC874LM-16FVA 5V	Flash	64	5.0	-40 to 125	Automotive
SAK-XC874CM-16FVA 5V	Flash	64	5.0	-40 to 125	Automotive
SAK-XC874-16FVA 5V	Flash	64	5.0	-40 to 125	Automotive
SAK-XC874LM-13FVA 5V	Flash	52	5.0	-40 to 125	Automotive
SAK-XC874CM-13FVA 5V	Flash	52	5.0	-40 to 125	Automotive
SAK-XC874-13FVA 5V	Flash	52	5.0	-40 to 125	Automotive

As this document refers to all the derivatives, some description may not apply to a specific product. For simplicity, all versions are referred to by the term XC87x throughout this document.

Ordering Information

The ordering code for Infineon Technologies microcontrollers provides an exact reference to the required product. This ordering code identifies:

- The derivative itself, i.e. its function set, the temperature range, and the supply voltage
- The package and the type of delivery

For the available ordering codes for the XC87x, please refer to your responsible sales representative or your local distributor.

2 General Device Information

Chapter 2 contains the block diagram, pin configurations, definitions and functions of the XC87x.

2.1 Block Diagram

The block diagram of the XC87x is shown in **Figure 2**.

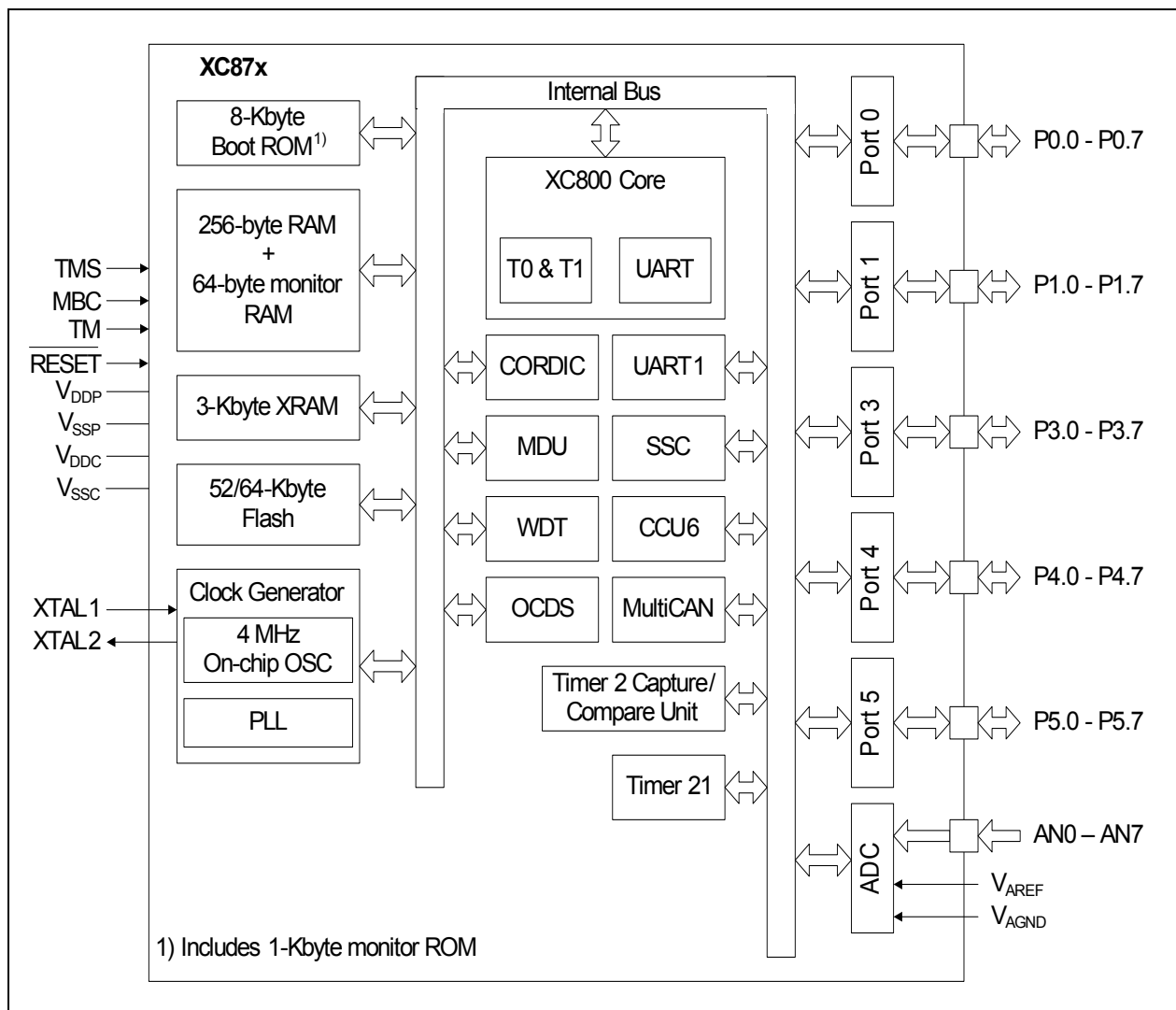

Figure 2 XC87x Block Diagram

2.2 Logic Symbol

The logic symbols of the XC878 and XC874 are shown in [Figure 3](#).



Figure 3 XC878 and XC874 Logic Symbol

2.3 Pin Configuration

The pin configuration of the XC878, which is based on the PG-LQFP-64, is shown in **Figure 4**, while that of the XC874, which is based on the PG-VQFN-48 package, is shown in **Figure 5**.



Figure 4 XC878 Pin Configuration, PG-LQFP-64 Package (top view)

2.4 Pin Definitions and Functions

The functions and default states of the XC87x external pins are provided in [Table 3](#).

Table 3 Pin Definitions and Functions

Symbol	Pin Number (LQFP-64 / VQFN-48)	Type	Reset State	Function
P0		I/O		Port 0 Port 0 is an 8-bit bidirectional general purpose I/O port. It can be used as alternate functions for the JTAG, CCU6, UART, UART1, T2CCU, Timer 21, MultiCAN, SSC and External Bus Interface. <i>Note: External Bus Interface is not available in XC874.</i>
P0.0	17/12		Hi-Z	TCK_0 JTAG Clock Input T12HR_1 CCU6 Timer 12 Hardware Run Input CC61_1 Input/Output of Capture/Compare channel 1 CLKOUT_0 Clock Output RXDO_1 UART Transmit Data Output
P0.1	21/14		Hi-Z	TDI_0 JTAG Serial Data Input T13HR_1 CCU6 Timer 13 Hardware Run Input RXD_1 UART Receive Data Input RXDC1_0 MultiCAN Node 1 Receiver Input COUT61_1 Output of Capture/Compare channel 1 EXF2_1 Timer 2 External Flag Output
P0.2	18/13		PU	CTRAP_2 CCU6 Trap Input TDO_0 JTAG Serial Data Output TXD_1 UART Transmit Data Output/Clock Output TXDC1_0 MultiCAN Node 1 Transmitter Output

General Device Information
Table 3 Pin Definitions and Functions (cont'd)

Symbol	Pin Number (LQFP-64 / VQFN-48)	Type	Reset State	Function
P0.3	63/1		Hi-Z	SCK_1 SSC Clock Input/Output COUT63_1 Output of Capture/Compare channel 3 RXD01_0 UART1 Transmit Data Output A17 Address Line 17 Output
P0.4	64/2		Hi-Z	MTSR_1 SSC Master Transmit Output/ Slave Receive Input CC62_1 Input/Output of Capture/Compare channel 2 TXD1_0 UART1 Transmit Data Output/Clock Output A18 Address Line 18 Output
P0.5	1/3		Hi-Z	MRST_1 SSC Master Receive Input/Slave Transmit Output EXINT0_0 External Interrupt Input 0 T2EX1_1 Timer 21 External Trigger Input RXD1_0 UART1 Receive Data Input COUT62_1 Output of Capture/Compare channel 2 A19 Address Line 19 Output
P0.6	2/4		PU	T2CC4_1 Compare Output Channel 4 WR External Data Write Control Output
P0.7	62/48		PU	CLKOUT_1 Clock Output T2CC5_1 Compare Output Channel 5 RD External Data Read Control Output

General Device Information
Table 3 Pin Definitions and Functions (cont'd)

Symbol	Pin Number (LQFP-64 / VQFN-48)	Type	Reset State	Function
P1		I/O		Port 1 Port 1 is an 8-bit bidirectional general purpose I/O port. It can be used as alternate functions for the JTAG, CCU6, UART, Timer 0, Timer 1, T2CCU, Timer 21, MultiCAN, SSC and External Bus Interface. <i>Note: External Bus Interface is not available in XC874.</i>
P1.0	34/25		PU	RXD_0 UART Receive Data Input T2EX_0 Timer 2 External Trigger Input RXDC0_0 MultiCAN Node 0 Receiver Input A8 Address Line 8 Output
P1.1	35/26		PU	EXINT3_0 External Interrupt Input 3 T0_1 Timer 0 Input TXD_0 UART Transmit Data Output/Clock Output TXDC0_0 MultiCAN Node 0 Transmitter Output A9 Address Line 9 Output
P1.2	36/27		PU	SCK_0 SSC Clock Input/Output A10 Address Line 10 Output
P1.3	37/28		PU	MTSR_0 SSC Master Transmit Output/Slave Receive Input SCK_2 SSC Clock Input/Output TXDC1_3 MultiCAN Node 1 Transmitter Output A11 Address Line 11 Output
P1.4	38/29		PU	MRST_0 SSC Master Receive Input/ Slave Transmit Output EXINT0_1 External Interrupt Input 0 RXDC1_3 MultiCAN Node 1 Receiver Input MTSR_2 SSC Master Transmit Output/Slave Receive Input A12 Address Line 12 Output

General Device Information
Table 3 Pin Definitions and Functions (cont'd)

Symbol	Pin Number (LQFP-64 / VQFN-48)	Type	Reset State	Function
P1.5	39/30		PU	CCPOS0_1 CCU6 Hall Input 0 EXINT5_0 External Interrupt Input 5 T1_1 Timer 1 Input MRST_2 SSC Master Receive Input/ Slave Transmit Output EXF2_0 Timer 2 External Flag Output RXDO_0 UART Transmit Data Output
P1.6	10/9		PU	CCPOS1_1 CCU6 Hall Input 1 T12HR_0 CCU6 Timer 12 Hardware Run Input EXINT6_0 External Interrupt Input 6 RXDC0_2 MultiCAN Node 0 Receiver Input T21_1 Timer 21 Input
P1.7	11/10		PU	CCPOS2_1 CCU6 Hall Input 2 T13HR_0 CCU6 Timer 13 Hardware Run Input T2_1 Timer 2 Input TXDC0_2 MultiCAN Node 0 Transmitter Output P1.5 and P1.6 can be used as a software chip select output for the SSC.

General Device Information
Table 3 Pin Definitions and Functions (cont'd)

Symbol	Pin Number (LQFP-64 / VQFN-48)	Type	Reset State	Function
P3		I/O		Port 3 Port 3 is an 8-bit bidirectional general purpose I/O port. It can be used as alternate functions for CCU6, UART1, T2CCU, Timer 21, MultiCAN and External Bus Interface. <i>Note: External Bus Interface is not available in XC874.</i>
P3.0	43/33		Hi-Z	CCPOS1_2 CCU6 Hall Input 1 CC60_0 Input/Output of Capture/Compare channel 0 RXD01_1 UART1 Transmit Data Output T2CC0_1/ EXINT3_2 External Interrupt Input 3/T2CCU Capture/Compare Channel 0
P3.1	44/34		Hi-Z	CCPOS0_2 CCU6 Hall Input 0 CC61_2 Input/Output of Capture/Compare channel 1 COUT60_0 Output of Capture/Compare channel 0 TXD1_1 UART1 Transmit Data Output/Clock Output
P3.2	49/35		Hi-Z	CCPOS2_2 CCU6 Hall Input 2 RXDC1_1 MultiCAN Node 1 Receiver Input RXD1_1 UART1 Receive Data Input CC61_0 Input/Output of Capture/Compare channel 1 T2CC1_1/ EXINT4_2 External Interrupt Input 4/T2CCU Capture/Compare Channel 1
P3.3	50/36		Hi-Z	COUT61_0 Output of Capture/Compare channel 1 TXDC1_1 MultiCAN Node 1 Transmitter Output T2CC2_1/ EXINT5_2 External Interrupt Input 5/T2CCU Capture/Compare Channel 2 A13 Address Line 13 Output

General Device Information
Table 3 Pin Definitions and Functions (cont'd)

Symbol	Pin Number (LQFP-64 / VQFN-48)	Type	Reset State	Function
P3.4	51/37		Hi-Z	CC62_0 Input/Output of Capture/Compare channel 2 RXDC0_1 MultiCAN Node 0 Receiver Input T2EX1_0 Timer 21 External Trigger Input T2CC3_1/ External Interrupt Input 6/T2CCU EXINT6_3 Capture/Compare Channel 3 A14 Address Line 14 Output
P3.5	52/38		Hi-Z	COUT62_0 Output of Capture/Compare channel 2 EXF21_0 Timer 21 External Flag Output TXDC0_1 MultiCAN Node 0 Transmitter Output A15 Address Line 15 Output
P3.6	41/32		PU	$\overline{\text{CTRAP}}_0$ CCU6 Trap Input
P3.7	42/-		Hi-Z	EXINT4_0 External Interrupt Input 4 COUT63_0 Output of Capture/Compare channel 3 A16 Address Line 16 Output

General Device Information
Table 3 Pin Definitions and Functions (cont'd)

Symbol	Pin Number (LQFP-64 / VQFN-48)	Type	Reset State	Function
P4		I/O		Port 4 Port 4 is an 8-bit bidirectional general purpose I/O port. It can be used as alternate functions for CCU6, Timer 0, Timer 1, T2CCU, Timer 21, MultiCAN and External Bus Interface. <i>Note: External Bus Interface is not available in XC874.</i>
P4.0	59/45		Hi-Z	RXDC0_3 MultiCAN Node 0 Receiver Input CC60_1 Output of Capture/Compare channel 0 T2CC0_0/ External Interrupt Input 3/T2CCU EXINT3_1 Capture/Compare Channel 0 D0 Data Line 0 Input/Output
P4.1	60/46		Hi-Z	TXDC0_3 MultiCAN Node 0 Transmitter Output COU60_1 Output of Capture/Compare channel 0 T2CC1_0/ External Interrupt Input 4/T2CCU EXINT4_1 Capture/Compare Channel 1 D1 Data Line 1 Input/Output
P4.2	61/47		PU	EXINT6_1 External Interrupt Input 6 T21_0 Timer 21 Input D2 Data Line 2 Input/Output
P4.3	40/31		Hi-Z	T2EX_1 Timer 2 External Trigger Input EXF21_1 Timer 21 External Flag Output COU63_2 Output of Capture/Compare channel 3 D3 Data Line 3 Input/Output
P4.4	45/-		Hi-Z	CCPOS0_3 CCU6 Hall Input 0 T0_0 Timer 0 Input CC61_4 Output of Capture/Compare channel 1 T2CC2_0/ External Interrupt Input 5/T2CCU EXINT5_1 Capture/Compare Channel 2 D4 Data Line 4 Input/Output

General Device Information
Table 3 Pin Definitions and Functions (cont'd)

Symbol	Pin Number (LQFP-64 / VQFN-48)	Type	Reset State	Function
P4.5	46/-		Hi-Z	CCPOS1_3 CCU6 Hall Input 1 T1_0 Timer 1 Input COUT61_2 Output of Capture/Compare channel 1 T2CC3_0/ External Interrupt Input 6/T2CCU EXINT6_2 Capture/Compare Channel 3 D5 Data Line 5 Input/Output
P4.6	47/-		Hi-Z	CCPOS2_3 CCU6 Hall Input 2 T2_0 Timer 2 Input CC62_2 Output of Capture/Compare channel 2 T2CC4_0 Compare Output Channel 4 D6 Data Line 6 Input/Output
P4.7	48/-		Hi-Z	CTRAP_3 CCU6 Trap Input COUT62_2 Output of Capture/Compare channel 2 T2CC5_0 Compare Output Channel 5 D7 Data Line 7 Input/Output

General Device Information
Table 3 Pin Definitions and Functions (cont'd)

Symbol	Pin Number (LQFP-64 / VQFN-48)	Type	Reset State	Function
P5		I/O		Port 5 Port 5 is an 8-bit bidirectional general purpose I/O port. It can be used as alternate functions for UART, UART1, T2CCU, JTAG and External Interface.
P5.0	8/-		PU	EXINT1_1 External Interrupt Input 1 A0 Address Line 0 Output
P5.1	9/-		PU	EXINT2_1 External Interrupt Input 2 A1 Address Line 1 Output
P5.2	12/-		PU	RXD_2 UART Receive Data Input T2CC2_2/ External Interrupt Input 5/T2CCU EXINT5_3 Capture/Compare Channel 2 A2 Address Line 2 Output
P5.3	13/-		PU	CCPOS0_0 CCU6 Hall Input 0 EXINT1_0 External Interrupt Input 1 T12HR_2 CCU6 Timer 12 Hardware Run Input CC61_3 Input of Capture/Compare channel 1 TXD_2 UART Transmit Data Output/Clock Output T2CC5_2 Compare Output Channel 5 A3 Address Line 3 Output
P5.4	14/-		PU	CCPOS1_0 CCU6 Hall Input 1 EXINT2_0 External Interrupt Input 2 T13HR_2 CCU6 Timer 13 Hardware Run Input CC62_3 Input of Capture/Compare channel 2 RXDO_2 UART Transmit Data Output T2CC4_2 Compare Output Channel 4 A4 Address Line 4 Output

General Device Information
Table 3 Pin Definitions and Functions (cont'd)

Symbol	Pin Number (LQFP-64 / VQFN-48)	Type	Reset State	Function
P5.5	15/-		PU	CCPOS2_0 CCU6 Hall Input 2 CTRAP_1 CCU6 Trap Input CC60_3 Input of Capture/Compare channel 0 TDO_1 JTAG Serial Data Output TXD1_2 UART1 Transmit Data Output/ Clock Output T2CC0_2/ EXINT3_3 External Interrupt Input 3/T2CCU Capture/Compare Channel 0 A5 Address Line 5 Output
P5.6	19/-		PU	TCK_1 JTAG Clock Input RXD01_2 UART1 Transmit Data Output T2CC1_2/ EXINT4_3 External Interrupt Input 4/T2CCU Capture/Compare Channel 1 A6 Address Line 6 Output
P5.7	20/-		PU	TDI_1 JTAG Serial Data Input RXD1_2 UART1 Receive Data Input T2CC3_2/ EXINT6_4 External Interrupt Input 6/T2CCU Capture/Compare Channel 3 A7 Address Line 7 Output

General Device Information

Table 3 Pin Definitions and Functions (cont'd)

Symbol	Pin Number (LQFP-64 / VQFN-48)	Type	Reset State	Function
V_{DDP}	7, 25, 55/ 17, 41	–	–	I/O Port Supply (3.3 or 5.0 V) Also used by EVR and analog modules. All pins must be connected.
V_{SSP}	26, 54/ 18, 40	–	–	I/O Ground All pins must be connected.
V_{DDC}	6/8	–	–	Core Supply Monitor (2.5 V)
V_{SSC}	5/7	–	–	Core Supply Ground
V_{AREF}	32/23	–	–	ADC Reference Voltage
V_{AGND}	31/22	–	–	ADC Reference Ground
AN0	22/-	I	Hi-Z	Analog Input 0
AN1	23/15	I	Hi-Z	Analog Input 1
AN2	24/16	I	Hi-Z	Analog Input 2
AN3	27/-	I	Hi-Z	Analog Input 3
AN4	28/19	I	Hi-Z	Analog Input 4
AN5	29/20	I	Hi-Z	Analog Input 5
AN6	30/21	I	Hi-Z	Analog Input 6
AN7	33/24	I	Hi-Z	Analog Input 7
XTAL1	4/6	I	Hi-Z	External Oscillator Input (Feedback resistor required, normally NC)
XTAL2	3/5	O	Hi-Z	External Oscillator Output (Feedback resistor required, normally NC)
TMS	16/11	I	PD	JTAG Test Mode Select
RESET	53/39	I	PU	Reset Input
MBC	58/44	I	PU	Monitor & BootStrap Loader Control
TM	57/43	–	–	Test Mode (External pull down device required)
NC	56/42	–	–	No Connection

3 Functional Description

Chapter 3 provides an overview of the XC87x functional description.

3.1 Processor Architecture

The XC87x is based on a high-performance 8-bit Central Processing Unit (CPU) that is compatible with the standard 8051 processor. While the standard 8051 processor is designed around a 12-clock machine cycle, the XC87x CPU uses a 2-clock machine cycle. This allows fast access to ROM or RAM memories without wait state. The instruction set consists of 45% one-byte, 41% two-byte and 14% three-byte instructions. The XC87x CPU provides a range of debugging features, including basic stop/start, single-step execution, breakpoint support and read/write access to the data memory, program memory and Special Function Registers (SFRs).

Figure 6 shows the CPU functional blocks.

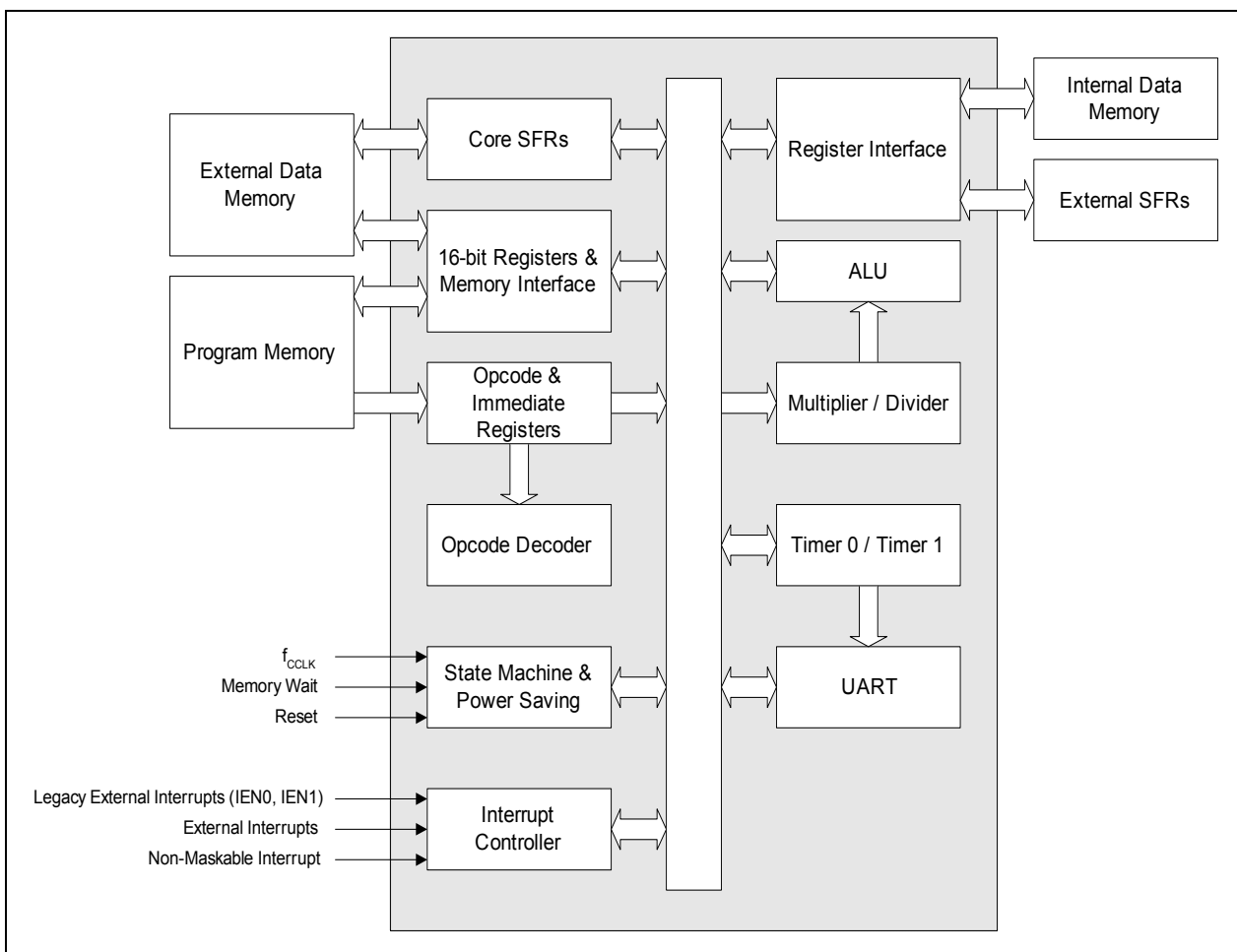

Figure 6 CPU Block Diagram

3.2 Memory Organization

The XC87x CPU operates in the following address spaces:

- 8 Kbytes of Boot ROM program memory
- 256 bytes of internal RAM data memory
- 3 Kbytes of XRAM memory
(XRAM can be read/written as program memory or external data memory)
- A 128-byte Special Function Register area
- 64/52 Kbytes of Flash program memory (Flash devices)

Figure 7 and Figure 8 illustrate the memory address spaces of the XC87x with 64Kbytes and 52Kbytes embedded Flash respectively.

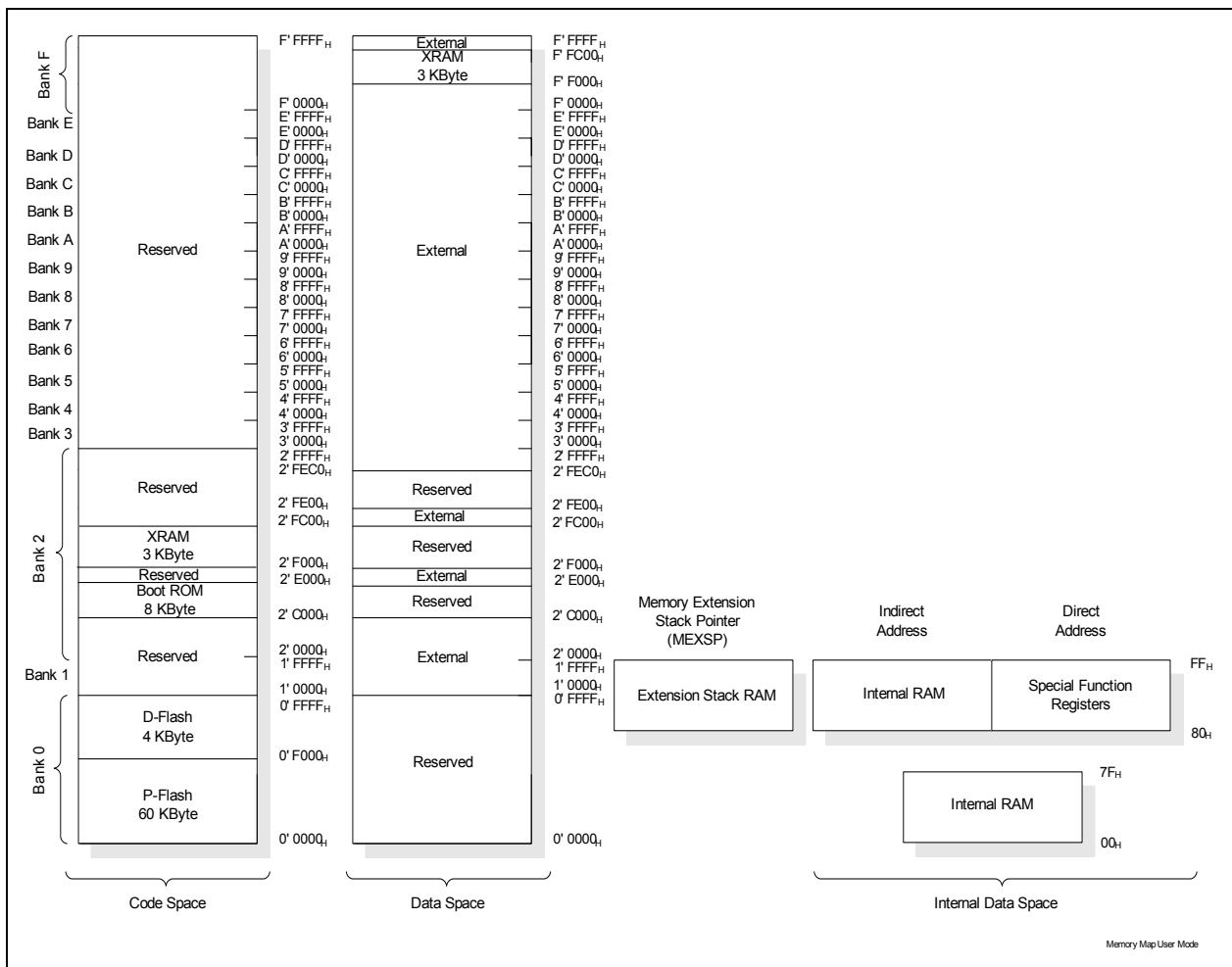

Figure 7 Memory Map of XC87x with 64K Flash Memory in user mode

Functional Description



Figure 8 Memory Map of XC87x with 52K Flash Memory in user mode

3.2.1 Memory Protection Strategy

The XC87x memory protection strategy includes:

- Basic protection: The user is able to block any external access via the boot option to any memory
- Read-out protection: The user is able to protect the contents in the Flash
- Flash program and erase protection

These protection strategies are enabled by programming a valid password (16-bit non-one value) via Bootstrap Loader (BSL) mode 6.

3.2.1.1 Flash Memory Protection

As long as a valid password is available, all external access to the device, including the Flash, will be blocked.

For additional security, the Flash hardware protection can be enabled to implement a second layer of read-out protection, as well as to enable program and erase protection.

Flash hardware protection is available only for Flash devices and comes in two modes:

- Mode 0: Only the P-Flash is protected; the D-Flash is unprotected
- Mode 1: Both the P-Flash and D-Flash are protected

The selection of each protection mode and the restrictions imposed are summarized in [Table 4](#).

Table 4 Flash Protection Modes

Flash Protection	Without hardware protection	With hardware protection	
Hardware Protection Mode	-	0	1
Activation	Program a valid password via BSL mode 6		
Selection	Bit 13 of password = 0	Bit 13 of password = 1 MSB of password = 0	Bit 13 of password = 1 MSB of password = 1
P-Flash contents can be read by	Read instructions in any program memory	Read instructions in the P-Flash	Read instructions in the P-Flash or D-Flash
External access to P-Flash	Not possible	Not possible	Not possible

Functional Description
Table 4 Flash Protection Modes (cont'd)

Flash Protection	Without hardware protection		With hardware protection	
P-Flash program and erase	Possible		Possible only on the condition that MSB - 1 of password is set to 1	Possible only on the condition that MSB - 1 of password is set to 1
D-Flash contents can be read by	Read instructions in any program memory		Read instructions in any program memory	Read instructions in the P-Flash or D-Flash
External access to D-Flash	Not possible		Not possible	Not possible
D-Flash program	Possible		Possible	Possible, on the condition that MSB - 1 of password is set to 1
D-Flash erase	Possible		Possible, on these conditions: <ul style="list-style-type: none"> • MISC_CON.DFLASH EN bit is set to 1 prior to each erase operation; or • the MSB - 1 of password is set to 1 	Possible, on the condition that MSB - 1 of password is set to 1

BSL mode 6, which is used for enabling Flash protection, can also be used for disabling Flash protection. Here, the programmed password must be provided by the user. To disable the flash protection, a password match is required. A password match triggers an automatic erase of the protected P-Flash and D-Flash contents, including the programmed password. With a valid password, the Flash hardware protection is then enabled or disabled upon next reset. For the other protection strategies, no reset is necessary.

Although no protection scheme can be considered infallible, the XC87x memory protection strategy provides a very high level of protection for a general purpose microcontroller.

Note: If ROM read-out protection is enabled, only read instructions in the ROM memory can target the ROM contents.

3.2.2 Special Function Register

The Special Function Registers (SFRs) occupy direct internal data memory space in the range 80_{H} to FF_{H} . All registers, except the program counter, reside in the SFR area. The SFRs include pointers and registers that provide an interface between the CPU and the on-chip peripherals. As the 128-SFR range is less than the total number of registers required, address extension mechanisms are required to increase the number of addressable SFRs. The address extension mechanisms include:

- Mapping
- Paging

3.2.2.1 Address Extension by Mapping

Address extension is performed at the system level by mapping. The SFR area is extended into two portions: the standard (non-mapped) SFR area and the mapped SFR area. Each portion supports the same address range 80_{H} to FF_{H} , bringing the number of addressable SFRs to 256. The extended address range is not directly controlled by the CPU instruction itself, but is derived from bit RMAP in the system control register SYSCON0 at address 8F_{H} . To access SFRs in the mapped area, bit RMAP in SFR SYSCON0 must be set. Alternatively, the SFRs in the standard area can be accessed by clearing bit RMAP. The SFR area can be selected as shown in [Figure 9](#).

As long as bit RMAP is set, the mapped SFR area can be accessed. This bit is not cleared automatically by hardware. Thus, before standard/mapped registers are accessed, bit RMAP must be cleared/set, respectively, by software.

Functional Description



Figure 9 Address Extension by Mapping

Functional Description

SYSCON0

System Control Register 0

Reset Value: 04_H

7	6	5	4	3	2	1	0
	0		IMODE	0	1	0	RMAP
	r		rw	r	r	r	rw

Field	Bits	Type	Description
RMAP	0	rw	Interrupt Node XINTR0 Enable 0 The access to the standard SFR area is enabled 1 The access to the mapped SFR area is enabled
1	2	r	Reserved Returns 1 if read; should be written with 1.
0	[7:5], 3,1	r	Reserved Returns 0 if read; should be written with 0.

Note: The RMAP bit should be cleared/set by ANL or ORL instructions. The rest bits of SYSCON0 should not be modified.

3.2.2.2 Address Extension by Paging

Address extension is further performed at the module level by paging. With the address extension by mapping, the XC87x has a 256-SFR address range. However, this is still less than the total number of SFRs needed by the on-chip peripherals. To meet this requirement, some peripherals have a built-in local address extension mechanism for increasing the number of addressable SFRs. The extended address range is not directly controlled by the CPU instruction itself, but is derived from bit field PAGE in the module page register MOD_PAGE. Hence, the bit field PAGE must be programmed before accessing the SFR of the target module. Each module may contain a different number of pages and a different number of SFRs per page, depending on the specific requirement. Besides setting the correct RMAP bit value to select the SFR area, the user must also ensure that a valid PAGE is selected to target the desired SFR. A page inside the extended address range can be selected as shown in [Figure 10](#).



Figure 10 Address Extension by Paging

In order to access a register located in a page different from the actual one, the current page must be exited. This is done by reprogramming the bit field PAGE in the page register. Only then can the desired access be performed.

If an interrupt routine is initiated between the page register access and the module register access, and the interrupt needs to access a register located in another page, the current page setting can be saved, the new one programmed and the old page setting restored. This is possible with the storage fields STx (x = 0 - 3) for the save and restore action of the current page setting. By indicating which storage bit field should be used in parallel with the new page value, a single write operation can:

- Save the contents of PAGE in STx before overwriting with the new value (this is done in the beginning of the interrupt routine to save the current page setting and program the new page number); or

Functional Description

- Overwrite the contents of PAGE with the contents of STx, ignoring the value written to the bit positions of PAGE
(this is done at the end of the interrupt routine to restore the previous page setting before the interrupt occurred)



Figure 11 Storage Elements for Paging

With this mechanism, a certain number of interrupt routines (or other routines) can perform page changes without reading and storing the previously used page information. The use of only write operations makes the system simpler and faster. Consequently, this mechanism significantly improves the performance of short interrupt routines.

The XC87x supports local address extension for:

- Parallel Ports
- Analog-to-Digital Converter (ADC)
- Capture/Compare Unit 6 (CCU6)
- System Control Registers

Functional Description

The page register has the following definition:

MOD_PAGE

Page Register for module MOD

Reset Value: 00_H



Field	Bits	Type	Description
PAGE	[2:0]	rw	<p>Page Bits When written, the value indicates the new page. When read, the value indicates the currently active page.</p>
STNR	[5:4]	w	<p>Storage Number This number indicates which storage bit field is the target of the operation defined by bit field OP. If OP = 10_B, the contents of PAGE are saved in STx before being overwritten with the new value. If OP = 11_B, the contents of PAGE are overwritten by the contents of STx. The value written to the bit positions of PAGE is ignored.</p> <p>00 ST0 is selected. 01 ST1 is selected. 10 ST2 is selected. 11 ST3 is selected.</p>

Functional Description

Field	Bits	Type	Description
OP	[7:6]	w	Operation 0X Manual page mode. The value of STNR is ignored and PAGE is directly written. 10 New page programming with automatic page saving. The value written to the bit positions of PAGE is stored. In parallel, the previous contents of PAGE are saved in the storage bit field STx indicated by STNR. 11 Automatic restore page action. The value written to the bit positions PAGE is ignored and instead, PAGE is overwritten by the contents of the storage bit field STx indicated by STNR.
0	3	r	Reserved Returns 0 if read; should be written with 0.

3.2.3 Bit Protection Scheme

The bit protection scheme prevents direct software writing of selected bits (i.e., protected bits) using the PASSWD register. When the bit field MODE is 11_B, writing 10011_B to the bit field PASS opens access to writing of all protected bits, and writing 10101_B to the bit field PASS closes access to writing of all protected bits. In both cases, the value of the bit field MODE is not changed even if PASSWD register is written with 98_H or A8_H. It can only be changed when bit field PASS is written with 11000_B, for example, writing D0_H to PASSWD register disables the bit protection scheme.

Note that access is opened for maximum 32 CCLKs if the “close access” password is not written. If “open access” password is written again before the end of 32 CCLK cycles, there will be a recount of 32 CCLK cycles. The protected bits include the N- and K-Divider bits, NDIV and KDIV; the Watchdog Timer enable bit, WDTEN; and the power-down and slow-down enable bits, PD and SD.

Functional Description

3.2.3.1 Password Register

PASSWD

Password Register

Reset Value: 07_H

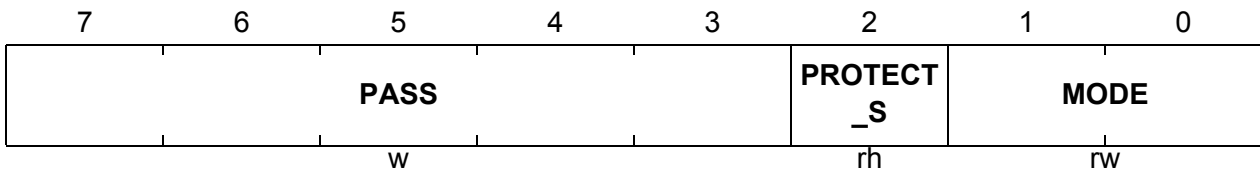

Field	Bits	Type	Description
MODE	[1:0]	rw	<p>Bit Protection Scheme Control Bits</p> <p>00 Scheme disabled - direct access to the protected bits is allowed.</p> <p>11 Scheme enabled - the bit field PASS has to be written with the passwords to open and close the access to protected bits. (default)</p> <p>Others: Scheme Enabled.</p> <p>These two bits cannot be written directly. To change the value between 11_B and 00_B, the bit field PASS must be written with 11000_B; only then, will the MODE[1:0] be registered.</p>
PROTECT_S	2	rh	<p>Bit Protection Signal Status Bit</p> <p>This bit shows the status of the protection.</p> <p>0 Software is able to write to all protected bits.</p> <p>1 Software is unable to write to any protected bits.</p>
PASS	[7:3]	w	<p>Password Bits</p> <p>The Bit Protection Scheme only recognizes three patterns.</p> <p>11000_B Enables writing of the bit field MODE.</p> <p>10011_B Opens access to writing of all protected bits.</p> <p>10101_B Closes access to writing of all protected bits</p>

Functional Description
3.2.4 XC87x Register Overview

The SFRs of the XC87x are organized into groups according to their functional units. The contents (bits) of the SFRs are summarized in [Chapter 3.2.4.1](#) to [Chapter 3.2.4.15](#).

Note: The addresses of the bitaddressable SFRs appear in bold typeface.

3.2.4.1 CPU Registers

The CPU SFRs can be accessed in both the standard and mapped memory areas (RMAP = 0 or 1).

Table 5 CPU Register Overview

Addr	Register Name	Bit	7	6	5	4	3	2	1	0	
RMAP = 0 or 1											
81 _H	SP Stack Pointer Register Reset: 07 _H	Bit Field	SP								
		Type	rw								
82 _H	DPL Data Pointer Register Low Reset: 00 _H	Bit Field	DPL7	DPL6	DPL5	DPL4	DPL3	DPL2	DPL1	DPL0	
		Type	rw	rw	rw	rw	rw	rw	rw	rw	
83 _H	DPH Data Pointer Register High Reset: 00 _H	Bit Field	DPH7	DPH6	DPH5	DPH4	DPH3	DPH2	DPH1	DPH0	
		Type	rw	rw	rw	rw	rw	rw	rw	rw	
87 _H	PCON Power Control Register Reset: 00 _H	Bit Field	SMOD	0			GF1	GF0	0	IDLE	
		Type	rw	r			rw	rw	r	rw	
88 _H	TCON Timer Control Register Reset: 00 _H	Bit Field	TF1	TR1	TF0	TR0	IE1	IT1	IE0	IT0	
		Type	rwh	rw	rwh	rw	rwh	rw	rwh	rw	
89 _H	TMOD Timer Mode Register Reset: 00 _H	Bit Field	GATE 1	T1S	T1M		GATE 0	T0S	T0M		
		Type	rw	rw	rw		rw	rw	rw		
8A _H	TL0 Timer 0 Register Low Reset: 00 _H	Bit Field	VAL								
		Type	rwh								
8B _H	TL1 Timer 1 Register Low Reset: 00 _H	Bit Field	VAL								
		Type	rwh								
8C _H	TH0 Timer 0 Register High Reset: 00 _H	Bit Field	VAL								
		Type	rwh								
8D _H	TH1 Timer 1 Register High Reset: 00 _H	Bit Field	VAL								
		Type	rwh								
94 _H	MEX1 Memory Extension Register 1 Reset: 00 _H	Bit Field	CB				NB				
		Type	r				rw				
95 _H	MEX2 Memory Extension Register 2 Reset: 00 _H	Bit Field	MCM	MCB			IB				
		Type	rw	rw			rw				
96 _H	MEX3 Memory Extension Register 3 Reset: 00 _H	Bit Field	MCB1 9	0		MXB1 9	MXM	MXB			
		Type	rw	r		rw	rw	rw			

Functional Description
Table 5 CPU Register Overview (cont'd)

Addr	Register Name	Bit	7	6	5	4	3	2	1	0
97 _H	MEXSP Reset: 7F_H Memory Extension Stack Pointer Register	Bit Field	0	MXSP						
		Type	r	rwh						
98 _H	SCON Reset: 00_H Serial Channel Control Register	Bit Field	SM0	SM1	SM2	REN	TB8	RB8	TI	RI
		Type	rw	rw	rw	rw	rw	rwh	rwh	rwh
99 _H	SBUF Reset: 00_H Serial Data Buffer Register	Bit Field	VAL							
		Type	rwh							
A2 _H	EO Reset: 00_H Extended Operation Register	Bit Field	0			TRAP_	0			DPSE
		Type	r			rw	r			rw
A8 _H	IEN0 Reset: 00_H Interrupt Enable Register 0	Bit Field	EA	0	ET2	ES	ET1	EX1	ET0	EX0
		Type	rw	r	rw	rw	rw	rw	rw	rw
B8 _H	IP Reset: 00_H Interrupt Priority Register	Bit Field	0		PT2	PS	PT1	PX1	PT0	PX0
		Type	r		rw	rw	rw	rw	rw	rw
B9 _H	IPH Reset: 00_H Interrupt Priority High Register	Bit Field	0		PT2H	PSH	PT1H	PX1H	PT0H	PX0H
		Type	r		rw	rw	rw	rw	rw	rw
D0 _H	PSW Reset: 00_H Program Status Word Register	Bit Field	CY	AC	F0	RS1	RS0	OV	F1	P
		Type	rwh	rwh	rw	rw	rw	rwh	rw	rh
E0 _H	ACC Reset: 00_H Accumulator Register	Bit Field	ACC7	ACC6	ACC5	ACC4	ACC3	ACC2	ACC1	ACC0
		Type	rw	rw	rw	rw	rw	rw	rw	rw
E8 _H	IEN1 Reset: 00_H Interrupt Enable Register 1	Bit Field	ECCIP	ECCIP	ECCIP	ECCIP	EXM	EX2	ESSC	EADC
		Type	rw	rw	rw	rw	rw	rw	rw	rw
F0 _H	B Reset: 00_H B Register	Bit Field	B7	B6	B5	B4	B3	B2	B1	B0
		Type	rw	rw	rw	rw	rw	rw	rw	rw
F8 _H	IP1 Reset: 00_H Interrupt Priority 1 Register	Bit Field	PCCIP	PCCIP	PCCIP	PCCIP	PXM	PX2	PSSC	PADC
		Type	rw	rw	rw	rw	rw	rw	rw	rw
F9 _H	IPH1 Reset: 00_H Interrupt Priority 1 High Register	Bit Field	PCCIP	PCCIP	PCCIP	PCCIP	PXMH	PX2H	PSSC	PADC
		Type	rw	rw	rw	rw	rw	rw	rw	rw

3.2.4.2 MDU Registers

The MDU SFRs can be accessed in the mapped memory area (RMAP = 1).

Table 6 MDU Register Overview

Addr	Register Name	Bit	7	6	5	4	3	2	1	0	
RMAP = 1											
B0 _H	MDUSTAT Reset: 00_H MDU Status Register	Bit Field	0				BSY	IERR	IRDY		
		Type	r				rh	rwh	rwh		

Table 6 MDU Register Overview (cont'd)

Addr	Register Name	Bit	7	6	5	4	3	2	1	0
B1 _H	MDUCON Reset: 00_H MDU Control Register	Bit Field	IE	IR	RSEL	STAR T	OPCODE			
		Type	rw	rw	rw	rwh	rw			
B2 _H	MD0 Reset: 00_H MDU Operand Register 0	Bit Field	DATA							
		Type	rw							
B2 _H	MR0 Reset: 00_H MDU Result Register 0	Bit Field	DATA							
		Type	rh							
B3 _H	MD1 Reset: 00_H MDU Operand Register 1	Bit Field	DATA							
		Type	rw							
B3 _H	MR1 Reset: 00_H MDU Result Register 1	Bit Field	DATA							
		Type	rh							
B4 _H	MD2 Reset: 00_H MDU Operand Register 2	Bit Field	DATA							
		Type	rw							
B4 _H	MR2 Reset: 00_H MDU Result Register 2	Bit Field	DATA							
		Type	rh							
B5 _H	MD3 Reset: 00_H MDU Operand Register 3	Bit Field	DATA							
		Type	rw							
B5 _H	MR3 Reset: 00_H MDU Result Register 3	Bit Field	DATA							
		Type	rh							
B6 _H	MD4 Reset: 00_H MDU Operand Register 4	Bit Field	DATA							
		Type	rw							
B6 _H	MR4 Reset: 00_H MDU Result Register 4	Bit Field	DATA							
		Type	rh							
B7 _H	MD5 Reset: 00_H MDU Operand Register 5	Bit Field	DATA							
		Type	rw							
B7 _H	MR5 Reset: 00_H MDU Result Register 5	Bit Field	DATA							
		Type	rh							

3.2.4.3 CORDIC Registers

The CORDIC SFRs can be accessed in the mapped memory area (RMAP = 1).

Table 7 CORDIC Register Overview

Addr	Register Name	Bit	7	6	5	4	3	2	1	0
RMAP = 1										
9A _H	CD_CORDXL Reset: 00_H CORDIC X Data Low Byte	Bit Field	DATA _L							
		Type	rw							
9B _H	CD_CORDXH Reset: 00_H CORDIC X Data High Byte	Bit Field	DATA _H							
		Type	rw							

Functional Description
Table 7 CORDIC Register Overview (cont'd)

Addr	Register Name	Bit	7	6	5	4	3	2	1	0
9C _H	CD_CORDYL Reset: 00 _H CORDIC Y Data Low Byte	Bit Field	DATAL							
		Type	rw							
9D _H	CD_CORDYH Reset: 00 _H CORDIC Y Data High Byte	Bit Field	DATAH							
		Type	rw							
9E _H	CD_CORDZL Reset: 00 _H CORDIC Z Data Low Byte	Bit Field	DATAL							
		Type	rw							
9F _H	CD_CORDZH Reset: 00 _H CORDIC Z Data High Byte	Bit Field	DATAH							
		Type	rw							
A0 _H	CD_STATC Reset: 00 _H CORDIC Status and Data Control Register	Bit Field	KEEP Z	KEEP Y	KEEP X	DMAP	INT_EN	EOC	ERROR	BSY
		Type	rw	rw	rw	rw	rw	rwh	rh	rh
A1 _H	CD_CON Reset: 00 _H CORDIC Control Register	Bit Field	MPS		X_USIGN	ST_MODE	ROTV EC	MODE		ST
		Type	rw		rw	rw	rw	rw		rwh

3.2.4.4 System Control Registers

The system control SFRs can be accessed in the mapped memory area (RMAP = 0).

Table 8 SCU Register Overview

Addr	Register Name	Bit	7	6	5	4	3	2	1	0
RMAP = 0 or 1										
8F _H	SYSCON0 Reset: 04 _H System Control Register 0	Bit Field	0		IMODE	0	1	0	RMAP	
		Type	r		rw	r	r	r	rw	
RMAP = 0										
BF _H	SCU_PAGE Reset: 00 _H Page Register	Bit Field	OP		STNR		0	PAGE		
		Type	w		w		r	rwh		
RMAP = 0, PAGE 0										
B3 _H	MODPSEL Reset: 00 _H Peripheral Input Select Register	Bit Field	0	URRISH	JTAGT DIS	JTAGT CKS	EXINT 2IS	EXINT 1IS	EXINT 0IS	URRIS
		Type	r	rw	rw	rw	rw	rw	rw	rw
B4 _H	IRCON0 Reset: 00 _H Interrupt Request Register 0	Bit Field	0	EXINT 6	EXINT 5	EXINT 4	EXINT 3	EXINT 2	EXINT 1	EXINT 0
		Type	r	rwh	rwh	rwh	rwh	rwh	rwh	rwh
B5 _H	IRCON1 Reset: 00 _H Interrupt Request Register 1	Bit Field	0	CANS RC2	CANS RC1	ADCS R1	ADCS R0	RIR	TIR	EIR
		Type	r	rwh	rwh	rw	rw	rwh	rwh	rw
B6 _H	IRCON2 Reset: 00 _H Interrupt Request Register 2	Bit Field	0			CANS RC3	0			CANS RC0
		Type	r			rw	r			rw

Functional Description
Table 8 SCU Register Overview (cont'd)

Addr	Register Name	Bit	7	6	5	4	3	2	1	0	
B7 _H	EXICON0 Reset: F0 _H External Interrupt Control Register 0	Bit Field	EXINT3		EXINT2		EXINT1		EXINT0		
		Type	rw		rw		rw		rw		
BA _H	EXICON1 Reset: 3F _H External Interrupt Control Register 1	Bit Field	0		EXINT6		EXINT5		EXINT4		
		Type	r		rw		rw		rw		
BB _H	NMICON Reset: 00 _H NMI Control Register	Bit Field	0	NMI ECC	NMI VDDP	0	NMI OCDS	NMI FLASH	NMI PLL	NMI WDT	
		Type	r	rw	rw	r	rw	rw	rw	rw	
BC _H	NMISR Reset: 00 _H NMI Status Register	Bit Field	0	FNMI ECC	FNMI VDDP	0	FNMI OCDS	FNMI FLASH	FNMI PLL	FNMI WDT	
		Type	r	rwh	rwh	r	rwh	rwh	rwh	rwh	
BD _H	BCON Reset: 20 _H Baud Rate Control Register	Bit Field	BGSEL		NDOV EN	BRDIS	BRPRE			R	
		Type	rw		rw	rw	rw			rw	
BE _H	BG Reset: 00 _H Baud Rate Timer/Reload Register	Bit Field	BR_VALUE								
		Type	rwh								
E9 _H	FDCON Reset: 00 _H Fractional Divider Control Register	Bit Field	BGS	SYNE N	ERRS YN	EOFS YN	BRK	NDOV	FDM	FDEN	
		Type	rw	rw	rwh	rwh	rw	rwh	rw	rw	
EA _H	FDSTEP Reset: 00 _H Fractional Divider Reload Register	Bit Field	STEP								
		Type	rw								
EB _H	FDRES Reset: 00 _H Fractional Divider Result Register	Bit Field	RESULT								
		Type	rh								
RMAP = 0, PAGE 1											
B3 _H	ID Reset: 49 _H Identity Register	Bit Field	PRODID					VERID			
		Type	r					r			
B4 _H	PMCON0 Reset: 80 _H Power Mode Control Register 0	Bit Field	VDDP WARN	WDT RST	WKRS	WK SEL	SD	PD	WS		
		Type	rh	rwh	rwh	rw	rw	rwh	rw		
B5 _H	PMCON1 Reset: 00 _H Power Mode Control Register 1	Bit Field	0	CDC_ DIS	CAN_ DIS	MDU_ DIS	T2CC U_DIS	CCU_ DIS	SSC_ DIS	ADC_ DIS	
		Type	r	rw	rw	rw	rw	rw	rw	rw	
B6 _H	OSC_CON Reset: XX _H OSC Control Register	Bit Field	PLLRD RES	PLLBY P	PLLPD	0	XPD	OSC SS	EORD RES	EXTO SCR	
		Type	rwh	rwh	rw	r	rw	rwh	rwh	rh	
B7 _H	PLL_CON Reset: 18 _H PLL Control Register	Bit Field	NDIV						PLL_R	PLL_L OCK	
		Type	rw						rh	rh	
BA _H	CMCON Reset: 10 _H Clock Control Register	Bit Field	KDIV		0	FCCF G	CLKREL				
		Type	rw		r	rw	rw				

Functional Description
Table 8 SCU Register Overview (cont'd)

Addr	Register Name	Bit	7	6	5	4	3	2	1	0
BB _H	PASSWD Reset: 07 _H Password Register	Bit Field	PASS					PROT ECT_S	MODE	
		Type	w					rh	rw	
BE _H	COCON Reset: 00 _H Clock Output Control Register	Bit Field	COU TS	TLEN	0	COREL				
		Type	rw	rw	r	rw				
E9 _H	MISC_CON Reset: 00 _H Miscellaneous Control Register	Bit Field	ADCE TR0_ MUX	ADCE TR1_ MUX	0				DFLAS HEN	
		Type	rw	rw	r				rwh	
EA _H	PLL_CON1 Reset: 20 _H PLL Control Register 1	Bit Field	NDIV			PDIV				
		Type	rw			rw				
EB _H	CR_MISC Reset: 00 _H or 01 _H Reset Status Register	Bit Field	CCCC F G	MDUC CFG	CCUC CFG	T2CCF G	0		HDRS T	
		Type	rw	rw	rw	rw	r		rwh	
RMAP = 0, PAGE 3										
B3 _H	XADDRH Reset: F0 _H On-chip XRAM Address Higher Order	Bit Field	ADDRH							
		Type	rw							
B4 _H	IRCON3 Reset: 00 _H Interrupt Request Register 3	Bit Field	0	CANS RC5	CCU6 SR1	0	CANS RC4	CCU6 SR0		
		Type	r	rwh	rwh	r	rwh	rwh		
B5 _H	IRCON4 Reset: 00 _H Interrupt Request Register 4	Bit Field	0	CANS RC7	CCU6 SR3	0	CANS RC6	CCU6 SR2		
		Type	r	rwh	rwh	r	rwh	rwh		
B6 _H	MODIEN Reset: 07 _H Peripheral Interrupt Enable Register	Bit Field	0		CM5E N	CM4E N	RIREN	TIREN	EIREN	
		Type	r		rw	rw	rw	rw	rw	
B7 _H	MODPISEL1 Reset: 00 _H Peripheral Input Select Register 1	Bit Field	EXINT6IS		UR1RIS		T21EX IS	0		
		Type	rw		rw		rw	r		
BA _H	MODPISEL2 Reset: 00 _H Peripheral Input Select Register 2	Bit Field	0		T2EXI S	T21IS	T2IS	T1IS	T0IS	
		Type	r		rw	rw	rw	rw	rw	
BB _H	PMCON2 Reset: 00 _H Power Mode Control Register 2	Bit Field	0						UART 1_DIS	T21_D IS
		Type	r						rw	rw
BD _H	MODSUSP Reset: 01 _H Module Suspend Control Register	Bit Field	0	CCTS USP	T21SU SP	T2SUS P	T13SU SP	T12SU SP	WDTS USP	
		Type	r	rw	rw	rw	rw	rw	rw	
BE _H	MODPISEL3 Reset: 00 _H Peripheral Input Select Register 3	Bit Field	0		CIS		SIS		MIS	
		Type	r		rw		rw		rw	
EA _H	MODPISEL4 Reset: 00 _H Peripheral Input Select Register 4	Bit Field	0		EXINT5IS		EXINT4IS		EXINT3IS	
		Type	r		rw		rw		rw	

Functional Description
3.2.4.5 WDT Registers

The WDT SFRs can be accessed in the mapped memory area (RMAP = 1).

Table 9 WDT Register Overview

Addr	Register Name	Bit	7	6	5	4	3	2	1	0
RMAP = 1										
BB _H	WDTCON Reset: 00_H Watchdog Timer Control Register	Bit Field	0		WINB EN	WDTP R	0	WDTE N	WDTR S	WDTI N
		Type	r		rw	rh	r	rw	rwh	rw
BC _H	WDTREL Reset: 00_H Watchdog Timer Reload Register	Bit Field	WDTREL							
		Type	rw							
BD _H	WDTWINB Reset: 00_H Watchdog Window-Boundary Count Register	Bit Field	WDTWINB							
		Type	rw							
BE _H	WDTL Reset: 00_H Watchdog Timer Register Low	Bit Field	WDT							
		Type	rh							
BF _H	WDTH Reset: 00_H Watchdog Timer Register High	Bit Field	WDT							
		Type	rh							

3.2.4.6 Port Registers

The Port SFRs can be accessed in the standard memory area (RMAP = 0).

Table 10 Port Register Overview

Addr	Register Name	Bit	7	6	5	4	3	2	1	0
RMAP = 0										
B2 _H	PORT_PAGE Reset: 00_H Page Register	Bit Field	OP		STNR		0		PAGE	
		Type	w		w		r		rwh	
RMAP = 0, PAGE 0										
80 _H	P0_DATA Reset: 00_H P0 Data Register	Bit Field	P7	P6	P5	P4	P3	P2	P1	P0
		Type	rwh	rwh	rwh	rwh	rwh	rwh	rwh	rwh
86 _H	P0_DIR Reset: 00_H P0 Direction Register	Bit Field	P7	P6	P5	P4	P3	P2	P1	P0
		Type	rw	rw	rw	rw	rw	rw	rw	rw
90 _H	P1_DATA Reset: 00_H P1 Data Register	Bit Field	P7	P6	P5	P4	P3	P2	P1	P0
		Type	rwh	rwh	rwh	rwh	rwh	rwh	rwh	rwh
91 _H	P1_DIR Reset: 00_H P1 Direction Register	Bit Field	P7	P6	P5	P4	P3	P2	P1	P0
		Type	rw	rw	rw	rw	rw	rw	rw	rw
92 _H	P5_DATA Reset: 00_H P5 Data Register	Bit Field	P7	P6	P5	P4	P3	P2	P1	P0
		Type	rwh	rwh	rwh	rwh	rwh	rwh	rwh	rwh
93 _H	P5_DIR Reset: 00_H P5 Direction Register	Bit Field	P7	P6	P5	P4	P3	P2	P1	P0
		Type	rw	rw	rw	rw	rw	rw	rw	rw

Functional Description
Table 10 Port Register Overview (cont'd)

Addr	Register Name	Bit	7	6	5	4	3	2	1	0
B0 _H	P3_DATA Reset: 00_H P3 Data Register	Bit Field	P7	P6	P5	P4	P3	P2	P1	P0
		Type	rwh	rwh	rwh	rwh	rwh	rwh	rwh	rwh
B1 _H	P3_DIR Reset: 00_H P3 Direction Register	Bit Field	P7	P6	P5	P4	P3	P2	P1	P0
		Type	rw	rw	rw	rw	rw	rw	rw	rw
C8 _H	P4_DATA Reset: 00_H P4 Data Register	Bit Field	P7	P6	P5	P4	P3	P2	P1	P0
		Type	rwh	rwh	rwh	rwh	rwh	rwh	rwh	rwh
C9 _H	P4_DIR Reset: 00_H P4 Direction Register	Bit Field	P7	P6	P5	P4	P3	P2	P1	P0
		Type	rw	rw	rw	rw	rw	rw	rw	rw
RMAP = 0, PAGE 1										
80 _H	P0_PUDEL Reset: FF_H P0 Pull-Up/Pull-Down Select Register	Bit Field	P7	P6	P5	P4	P3	P2	P1	P0
		Type	rw	rw	rw	rw	rw	rw	rw	rw
86 _H	P0_PUEN Reset: C4_H P0 Pull-Up/Pull-Down Enable Register	Bit Field	P7	P6	P5	P4	P3	P2	P1	P0
		Type	rw	rw	rw	rw	rw	rw	rw	rw
90 _H	P1_PUDEL Reset: FF_H P1 Pull-Up/Pull-Down Select Register	Bit Field	P7	P6	P5	P4	P3	P2	P1	P0
		Type	rw	rw	rw	rw	rw	rw	rw	rw
91 _H	P1_PUEN Reset: FF_H P1 Pull-Up/Pull-Down Enable Register	Bit Field	P7	P6	P5	P4	P3	P2	P1	P0
		Type	rw	rw	rw	rw	rw	rw	rw	rw
92 _H	P5_PUDEL Reset: FF_H P5 Pull-Up/Pull-Down Select Register	Bit Field	P7	P6	P5	P4	P3	P2	P1	P0
		Type	rw	rw	rw	rw	rw	rw	rw	rw
93 _H	P5_PUEN Reset: FF_H P5 Pull-Up/Pull-Down Enable Register	Bit Field	P7	P6	P5	P4	P3	P2	P1	P0
		Type	rw	rw	rw	rw	rw	rw	rw	rw
B0 _H	P3_PUDEL Reset: BF_H P3 Pull-Up/Pull-Down Select Register	Bit Field	P7	P6	P5	P4	P3	P2	P1	P0
		Type	rw	rw	rw	rw	rw	rw	rw	rw
B1 _H	P3_PUEN Reset: 40_H P3 Pull-Up/Pull-Down Enable Register	Bit Field	P7	P6	P5	P4	P3	P2	P1	P0
		Type	rw	rw	rw	rw	rw	rw	rw	rw
C8 _H	P4_PUDEL Reset: FF_H P4 Pull-Up/Pull-Down Select Register	Bit Field	P7	P6	P5	P4	P3	P2	P1	P0
		Type	rw	rw	rw	rw	rw	rw	rw	rw
C9 _H	P4_PUEN Reset: 04_H P4 Pull-Up/Pull-Down Enable Register	Bit Field	P7	P6	P5	P4	P3	P2	P1	P0
		Type	rw	rw	rw	rw	rw	rw	rw	rw
RMAP = 0, PAGE 2										
80 _H	P0_ALTSEL0 Reset: 00_H P0 Alternate Select 0 Register	Bit Field	P7	P6	P5	P4	P3	P2	P1	P0
		Type	rw	rw	rw	rw	rw	rw	rw	rw
86 _H	P0_ALTSEL1 Reset: 00_H P0 Alternate Select 1 Register	Bit Field	P7	P6	P5	P4	P3	P2	P1	P0
		Type	rw	rw	rw	rw	rw	rw	rw	rw
90 _H	P1_ALTSEL0 Reset: 00_H P1 Alternate Select 0 Register	Bit Field	P7	P6	P5	P4	P3	P2	P1	P0
		Type	rw	rw	rw	rw	rw	rw	rw	rw

Functional Description
Table 10 Port Register Overview (cont'd)

Addr	Register Name	Bit	7	6	5	4	3	2	1	0
91 _H	P1_ALTSEL1 Reset: 00 _H P1 Alternate Select 1 Register	Bit Field	P7	P6	P5	P4	P3	P2	P1	P0
		Type	rw	rw	rw	rw	rw	rw	rw	rw
92 _H	P5_ALTSEL0 Reset: 00 _H P5 Alternate Select 0 Register	Bit Field	P7	P6	P5	P4	P3	P2	P1	P0
		Type	rw	rw	rw	rw	rw	rw	rw	rw
93 _H	P5_ALTSEL1 Reset: 00 _H P5 Alternate Select 1 Register	Bit Field	P7	P6	P5	P4	P3	P2	P1	P0
		Type	rw	rw	rw	rw	rw	rw	rw	rw
B0 _H	P3_ALTSEL0 Reset: 00 _H P3 Alternate Select 0 Register	Bit Field	P7	P6	P5	P4	P3	P2	P1	P0
		Type	rw	rw	rw	rw	rw	rw	rw	rw
B1 _H	P3_ALTSEL1 Reset: 00 _H P3 Alternate Select 1 Register	Bit Field	P7	P6	P5	P4	P3	P2	P1	P0
		Type	rw	rw	rw	rw	rw	rw	rw	rw
C8 _H	P4_ALTSEL0 Reset: 00 _H P4 Alternate Select 0 Register	Bit Field	P7	P6	P5	P4	P3	P2	P1	P0
		Type	rw	rw	rw	rw	rw	rw	rw	rw
C9 _H	P4_ALTSEL1 Reset: 00 _H P4 Alternate Select 1 Register	Bit Field	P7	P6	P5	P4	P3	P2	P1	P0
		Type	rw	rw	rw	rw	rw	rw	rw	rw
RMAP = 0, PAGE 3										
80 _H	P0_OD Reset: 00 _H P0 Open Drain Control Register	Bit Field	P7	P6	P5	P4	P3	P2	P1	P0
		Type	rw	rw	rw	rw	rw	rw	rw	rw
86 _H	P0_DS Reset: FF _H P0 Drive Strength Control Register	Bit Field	P7	P6	P5	P4	P3	P2	P1	P0
		Type	rw	rw	rw	rw	rw	rw	rw	rw
90 _H	P1_OD Reset: 00 _H P1 Open Drain Control Register	Bit Field	P7	P6	P5	P4	P3	P2	P1	P0
		Type	rw	rw	rw	rw	rw	rw	rw	rw
91 _H	P1_DS Reset: FF _H P1 Drive Strength Control Register	Bit Field	P7	P6	P5	P4	P3	P2	P1	P0
		Type	rw	rw	rw	rw	rw	rw	rw	rw
92 _H	P5_OD Reset: 00 _H P5 Open Drain Control Register	Bit Field	P7	P6	P5	P4	P3	P2	P1	P0
		Type	rw	rw	rw	rw	rw	rw	rw	rw
93 _H	P5_DS Reset: FF _H P5 Drive Strength Control Register	Bit Field	P7	P6	P5	P4	P3	P2	P1	P0
		Type	rw	rw	rw	rw	rw	rw	rw	rw
B0 _H	P3_OD Reset: 00 _H P3 Open Drain Control Register	Bit Field	P7	P6	P5	P4	P3	P2	P1	P0
		Type	rw	rw	rw	rw	rw	rw	rw	rw
B1 _H	P3_DS Reset: FF _H P3 Drive Strength Control Register	Bit Field	P7	P6	P5	P4	P3	P2	P1	P0
		Type	rw	rw	rw	rw	rw	rw	rw	rw
C8 _H	P4_OD Reset: 00 _H P4 Open Drain Control Register	Bit Field	P7	P6	P5	P4	P3	P2	P1	P0
		Type	rw	rw	rw	rw	rw	rw	rw	rw
C9 _H	P4_DS Reset: FF _H P4 Drive Strength Control Register	Bit Field	P7	P6	P5	P4	P3	P2	P1	P0
		Type	rw	rw	rw	rw	rw	rw	rw	rw

3.2.4.7 ADC Registers

The ADC SFRs can be accessed in the standard memory area (RMAP = 0).

Table 11 ADC Register Overview

Addr	Register Name	Bit	7	6	5	4	3	2	1	0
RMAP = 0										
D1 _H	ADC_PAGE Reset: 00 _H Page Register	Bit Field	OP		STNR		0	PAGE		
		Type	w		w		r	rw		
RMAP = 0, PAGE 0										
CA _H	ADC_GLOBCTR Reset: 30 _H Global Control Register	Bit Field	ANON	DW	CTC		0			
		Type	rw	rw	rw		r			
CB _H	ADC_GLOBSTR Reset: 00 _H Global Status Register	Bit Field	0		CHNR			0	SAMP LE	BUSY
		Type	r		rh			r	rh	rh
CC _H	ADC_PRAR Reset: 00 _H Priority and Arbitration Register	Bit Field	ASEN 1	ASEN 0	0	ARBM	CSM1	PRI01	CSM0	PRI00
		Type	rw	rw	r	rw	rw	rw	rw	rw
CD _H	ADC_LCBR Reset: B7 _H Limit Check Boundary Register	Bit Field	BOUND1				BOUND0			
		Type	rw				rw			
CE _H	ADC_INPCR0 Reset: 00 _H Input Class 0 Register	Bit Field	STC							
		Type	rw							
CF _H	ADC_ETRCR Reset: 00 _H External Trigger Control Register	Bit Field	SYNE N1	SYNE N0	ETRSEL1			ETRSEL0		
		Type	rw	rw	rw			rw		
RMAP = 0, PAGE 1										
CA _H	ADC_CHCTR0 Reset: 00 _H Channel Control Register 0	Bit Field	0	LCC			0	RESRSEL		
		Type	r	rw			r	rw		
CB _H	ADC_CHCTR1 Reset: 00 _H Channel Control Register 1	Bit Field	0	LCC			0	RESRSEL		
		Type	r	rw			r	rw		
CC _H	ADC_CHCTR2 Reset: 00 _H Channel Control Register 2	Bit Field	0	LCC			0	RESRSEL		
		Type	r	rw			r	rw		
CD _H	ADC_CHCTR3 Reset: 00 _H Channel Control Register 3	Bit Field	0	LCC			0	RESRSEL		
		Type	r	rw			r	rw		
CE _H	ADC_CHCTR4 Reset: 00 _H Channel Control Register 4	Bit Field	0	LCC			0	RESRSEL		
		Type	r	rw			r	rw		
CF _H	ADC_CHCTR5 Reset: 00 _H Channel Control Register 5	Bit Field	0	LCC			0	RESRSEL		
		Type	r	rw			r	rw		
D2 _H	ADC_CHCTR6 Reset: 00 _H Channel Control Register 6	Bit Field	0	LCC			0	RESRSEL		
		Type	r	rw			r	rw		
D3 _H	ADC_CHCTR7 Reset: 00 _H Channel Control Register 7	Bit Field	0	LCC			0	RESRSEL		
		Type	r	rw			r	rw		

Functional Description
Table 11 ADC Register Overview (cont'd)

Addr	Register Name	Bit	7	6	5	4	3	2	1	0
RMAP = 0, PAGE 2										
CA _H	ADC_RESR0L Reset: 00 _H Result Register 0 Low	Bit Field	RESULT	0	VF	DRC	CHNR			
		Type	rh	r	rh	rh	rh			
CB _H	ADC_RESR0H Reset: 00 _H Result Register 0 High	Bit Field	RESULT							
		Type	rh							
CC _H	ADC_RESR1L Reset: 00 _H Result Register 1 Low	Bit Field	RESULT	0	VF	DRC	CHNR			
		Type	rh	r	rh	rh	rh			
CD _H	ADC_RESR1H Reset: 00 _H Result Register 1 High	Bit Field	RESULT							
		Type	rh							
CE _H	ADC_RESR2L Reset: 00 _H Result Register 2 Low	Bit Field	RESULT	0	VF	DRC	CHNR			
		Type	rh	r	rh	rh	rh			
CF _H	ADC_RESR2H Reset: 00 _H Result Register 2 High	Bit Field	RESULT							
		Type	rh							
D2 _H	ADC_RESR3L Reset: 00 _H Result Register 3 Low	Bit Field	RESULT	0	VF	DRC	CHNR			
		Type	rh	r	rh	rh	rh			
D3 _H	ADC_RESR3H Reset: 00 _H Result Register 3 High	Bit Field	RESULT							
		Type	rh							
RMAP = 0, PAGE 3										
CA _H	ADC_RESRA0L Reset: 00 _H Result Register 0, View A Low	Bit Field	RESULT		VF	DRC	CHNR			
		Type	rh		rh	rh	rh			
CB _H	ADC_RESRA0H Reset: 00 _H Result Register 0, View A High	Bit Field	RESULT							
		Type	rh							
CC _H	ADC_RESRA1L Reset: 00 _H Result Register 1, View A Low	Bit Field	RESULT		VF	DRC	CHNR			
		Type	rh		rh	rh	rh			
CD _H	ADC_RESRA1H Reset: 00 _H Result Register 1, View A High	Bit Field	RESULT							
		Type	rh							
CE _H	ADC_RESRA2L Reset: 00 _H Result Register 2, View A Low	Bit Field	RESULT		VF	DRC	CHNR			
		Type	rh		rh	rh	rh			
CF _H	ADC_RESRA2H Reset: 00 _H Result Register 2, View A High	Bit Field	RESULT							
		Type	rh							
D2 _H	ADC_RESRA3L Reset: 00 _H Result Register 3, View A Low	Bit Field	RESULT		VF	DRC	CHNR			
		Type	rh		rh	rh	rh			
D3 _H	ADC_RESRA3H Reset: 00 _H Result Register 3, View A High	Bit Field	RESULT							
		Type	rh							
RMAP = 0, PAGE 4										
CA _H	ADC_RCR0 Reset: 00 _H Result Control Register 0	Bit Field	VFCT R	WFR	0	IEN	0			DRCT R
		Type	rw	rw	r	rw	r			rw

Functional Description
Table 11 ADC Register Overview (cont'd)

Addr	Register Name	Bit	7	6	5	4	3	2	1	0
CB _H	ADC_RCR1 Reset: 00_H Result Control Register 1	Bit Field	VFCT R	WFR	0	IEN	0			DRCT R
		Type	rw	rw	r	rw	r			rw
CC _H	ADC_RCR2 Reset: 00_H Result Control Register 2	Bit Field	VFCT R	WFR	0	IEN	0			DRCT R
		Type	rw	rw	r	rw	r			rw
CD _H	ADC_RCR3 Reset: 00_H Result Control Register 3	Bit Field	VFCT R	WFR	0	IEN	0			DRCT R
		Type	rw	rw	r	rw	r			rw
CE _H	ADC_VFCR Reset: 00_H Valid Flag Clear Register	Bit Field	0				VFC3	VFC2	VFC1	VFC0
		Type	r				w	w	w	w
RMAP = 0, PAGE 5										
CA _H	ADC_CHINFR Reset: 00_H Channel Interrupt Flag Register	Bit Field	CHINF 7	CHINF 6	CHINF 5	CHINF 4	CHINF 3	CHINF 2	CHINF 1	CHINF 0
		Type	rh	rh	rh	rh	rh	rh	rh	rh
CB _H	ADC_CHINCR Reset: 00_H Channel Interrupt Clear Register	Bit Field	CHINC 7	CHINC 6	CHINC 5	CHINC 4	CHINC 3	CHINC 2	CHINC 1	CHINC 0
		Type	w	w	w	w	w	w	w	w
CC _H	ADC_CHINSR Reset: 00_H Channel Interrupt Set Register	Bit Field	CHINS 7	CHINS 6	CHINS 5	CHINS 4	CHINS 3	CHINS 2	CHINS 1	CHINS 0
		Type	w	w	w	w	w	w	w	w
CD _H	ADC_CHINPR Reset: 00_H Channel Interrupt Node Pointer Register	Bit Field	CHINP 7	CHINP 6	CHINP 5	CHINP 4	CHINP 3	CHINP 2	CHINP 1	CHINP 0
		Type	rw	rw	rw	rw	rw	rw	rw	rw
CE _H	ADC_EVINFR Reset: 00_H Event Interrupt Flag Register	Bit Field	EVINF 7	EVINF 6	EVINF 5	EVINF 4	0		EVINF 1	EVINF 0
		Type	rh	rh	rh	rh	r		rh	rh
CF _H	ADC_EVINCR Reset: 00_H Event Interrupt Clear Flag Register	Bit Field	EVINC 7	EVINC 6	EVINC 5	EVINC 4	0		EVINC 1	EVINC 0
		Type	w	w	w	w	r		w	w
D2 _H	ADC_EVINSR Reset: 00_H Event Interrupt Set Flag Register	Bit Field	EVINS 7	EVINS 6	EVINS 5	EVINS 4	0		EVINS 1	EVINS 0
		Type	w	w	w	w	r		w	w
D3 _H	ADC_EVINPR Reset: 00_H Event Interrupt Node Pointer Register	Bit Field	EVINP 7	EVINP 6	EVINP 5	EVINP 4	0		EVINP 1	EVINP 0
		Type	rw	rw	rw	rw	r		rw	rw
RMAP = 0, PAGE 6										
CA _H	ADC_CRCR1 Reset: 00_H Conversion Request Control Register 1	Bit Field	CH7	CH6	CH5	CH4	0			
		Type	rwh	rwh	rwh	rwh	r			
CB _H	ADC_CRPR1 Reset: 00_H Conversion Request Pending Register 1	Bit Field	CHP7	CHP6	CHP5	CHP4	0			
		Type	rwh	rwh	rwh	rwh	r			

Functional Description
Table 11 ADC Register Overview (cont'd)

Addr	Register Name	Bit	7	6	5	4	3	2	1	0
CC _H	ADC_CRMR1 Reset: 00 _H Conversion Request Mode Register 1	Bit Field	Rsv	LDEV	CLRP ND	SCAN	ENSI	ENTR	0	ENGT
		Type	r	w	w	rw	rw	rw	r	rw
CD _H	ADC_QMR0 Reset: 00 _H Queue Mode Register 0	Bit Field	CEV	TREV	FLUS H	CLRV	0	ENTR	0	ENGT
		Type	w	w	w	w	r	rw	r	rw
CE _H	ADC_QSR0 Reset: 20 _H Queue Status Register 0	Bit Field	Rsv	0	EMPT Y	EV	0		FILL	
		Type	r	r	rh	rh	r		rh	
CF _H	ADC_Q0R0 Reset: 00 _H Queue 0 Register 0	Bit Field	EXTR	ENSI	RF	V	0	REQCHNR		
		Type	rh	rh	rh	rh	r	rh		
D2 _H	ADC_QBUR0 Reset: 00 _H Queue Backup Register 0	Bit Field	EXTR	ENSI	RF	V	0	REQCHNR		
		Type	rh	rh	rh	rh	r	rh		
D2 _H	ADC_QINR0 Reset: 00 _H Queue Input Register 0	Bit Field	EXTR	ENSI	RF	0		REQCHNR		
		Type	w	w	w	r		w		

Functional Description
3.2.4.8 Timer 2 Compare/Capture Unit Registers

The Timer 2 Compare/Capture Unit SFRs can be accessed in the standard memory area (RMAP = 0).

Table 12 T2CCU Register Overview

Addr	Register Name	Bit	7	6	5	4	3	2	1	0
RMAP = 0										
C7 _H	T2_PAGE Page Register Reset: 00 _H	Bit Field	OP		STNR		0	PAGE		
		Type	w		w		r	rwh		
RMAP = 0, PAGE 0										
C0 _H	T2_T2CON Timer 2 Control Register Reset: 00 _H	Bit Field	TF2	EXF2	0		EXEN 2	TR2	C/T ₂	CP/ RL2
		Type	rwh	rwh	r		rw	rwh	rw	rw
C1 _H	T2_T2MOD Timer 2 Mode Register Reset: 00 _H	Bit Field	T2RE GS	T2RH EN	EDGE SEL	PREN	T2PRE			DCEN
		Type	rw	rw	rw	rw	rw			rw
C2 _H	T2_RC2L Timer 2 Reload/Capture Register Low Reset: 00 _H	Bit Field	RC2							
		Type	rwh							
C3 _H	T2_RC2H Timer 2 Reload/Capture Register High Reset: 00 _H	Bit Field	RC2							
		Type	rwh							
C4 _H	T2_T2L Timer 2 Register Low Reset: 00 _H	Bit Field	THL2							
		Type	rwh							
C5 _H	T2_T2H Timer 2 Register High Reset: 00 _H	Bit Field	THL2							
		Type	rwh							
C6 _H	T2_T2CON1 Timer 2 Control Register 1 Reset: 03 _H	Bit Field	0						TF2EN	EXF2E N
		Type	r						rw	rw
RMAP = 0, PAGE 1										
C0 _H	T2CCU_CCEN T2CCU Capture/Compare Enable Register Reset: 00 _H	Bit Field	CCM3		CCM2		CCM1		CCM0	
		Type	rw		rw		rw		rw	
C1 _H	T2CCU_CCTBSEL T2CCU Capture/Compare Time Base Select Register Reset: 00 _H	Bit Field	CASC	CCTT OV	CCTB 5	CCTB 4	CCTB 3	CCTB 2	CCTB 1	CCTB 0
		Type	rw	rwh	rw	rw	rw	rw	rw	rw
C2 _H	T2CCU_CCTRELL T2CCU Capture/Compare Timer Reload Register Low Reset: 00 _H	Bit Field	CCTREL							
		Type	rw							
C3 _H	T2CCU_CCTRELH T2CCU Capture/Compare Timer Reload Register High Reset: 00 _H	Bit Field	CCTREL							
		Type	rw							
C4 _H	T2CCU_CCTL T2CCU Capture/Compare Timer Register Low Reset: 00 _H	Bit Field	CCT							
		Type	rwh							

Functional Description
Table 12 T2CCU Register Overview (cont'd)

Addr	Register Name	Bit	7	6	5	4	3	2	1	0	
C5 _H	T2CCU_CCTH Reset: 00 _H T2CCU Capture/Compare Timer Register High	Bit Field	CCT								
		Type	rwh								
C6 _H	T2CCU_CCTCON Reset: 00 _H T2CCU Capture/Compare Timer Control Register	Bit Field	CCTPRE				CCTO VF	CCTO VEN	TIMSY N	CCTS T	
		Type	rw				rwh	rw	rw	rw	rw
RMAP = 0, PAGE 2											
C0 _H	T2CCU_COSHDW Reset: 00 _H T2CCU Capture/compare Enable Register	Bit Field	ENSH DW	TXOV	COOU T5	COOU T4	COOU T3	COOU T2	COOU T1	COOU T0	
		Type	rwh	rwh	rwh	rwh	rwh	rwh	rwh	rwh	
C1 _H	T2CCU_CC0L Reset: 00 _H T2CCU Capture/Compare Register 0 Low	Bit Field	CCVALL								
		Type	rwh								
C2 _H	T2CCU_CC0H Reset: 00 _H T2CCU Capture/compare Register 0 High	Bit Field	CCVALH								
		Type	rwh								
C3 _H	T2CCU_CC1L Reset: 00 _H T2CCU Capture/compare Register 1 Low	Bit Field	CCVALL								
		Type	rwh								
C4 _H	T2CCU_CC1H Reset: 00 _H T2CCU Capture/compare Register 1 High	Bit Field	CCVALH								
		Type	rwh								
C5 _H	T2CCU_CC2L Reset: 00 _H T2CCU Capture/compare Register 2 Low	Bit Field	CCVALL								
		Type	rwh								
C6 _H	T2CCU_CC2H Reset: 00 _H T2CCU Capture/compare Register 2 High	Bit Field	CCVALH								
		Type	rwh								
RMAP = 0, PAGE 3											
C0 _H	T2CCU_COCON Reset: 00 _H T2CCU Compare Control Register	Bit Field	CCM5	CCM4	CM5F	CM4F	POLB	POLA	COMOD		
		Type	rw	rw	rwh	rwh	rw	rw	rw		
C1 _H	T2CCU_CC3L Reset: 00 _H T2CCU Capture/compare Register 3 Low	Bit Field	CCVALL								
		Type	rwh								
C2 _H	T2CCU_CC3H Reset: 00 _H T2CCU Capture/compare Register 3 High	Bit Field	CCVALH								
		Type	rwh								
C3 _H	T2CCU_CC4L Reset: 00 _H T2CCU Capture/compare Register 4 Low	Bit Field	CCVALL								
		Type	rwh								
C4 _H	T2CCU_CC4H Reset: 00 _H T2CCU Capture/compare Register 4 High	Bit Field	CCVALH								
		Type	rwh								
C5 _H	T2CCU_CC5L Reset: 00 _H T2CCU Capture/compare Register 5 Low	Bit Field	CCVALL								
		Type	rwh								
C6 _H	T2CCU_CC5H Reset: 00 _H T2CCU Capture/compare Register 5 High	Bit Field	CCVALH								
		Type	rwh								

Functional Description
Table 12 T2CCU Register Overview (cont'd)

Addr	Register Name	Bit	7	6	5	4	3	2	1	0
RMAP = 0, PAGE 4										
C2 _H	T2CCU_CCTDTCL Reset: 00 _H T2CCU Capture/Compare Timer Dead-Time Control Register Low	Bit Field	DTM							
		Type	rw							
C3 _H	T2CCU_CCTDTCH Reset: 00 _H T2CCU Capture/Compare Timer Dead-Time Control Register High	Bit Field	DTRE S	DTR2	DTR1	DTR0	DTLEV	DTE2	DTE1	DTE0
		Type	rwh	rh	rh	rh	rw	rw	rw	rw

3.2.4.9 Timer 21 Registers

The Timer 21 SFRs can be accessed in the mapped memory area (RMAP = 1).

Table 13 T21 Register Overview

Addr	Register Name	Bit	7	6	5	4	3	2	1	0
RMAP = 1										
C0 _H	T21_T2CON Reset: 00 _H Timer 2 Control Register	Bit Field	TF2	EXF2	0	EXEN 2	TR2	$\overline{C/T2}$	$\overline{CP/RL2}$	
		Type	rwh	rwh	r	rw	rwh	rw	rw	
C1 _H	T21_T2MOD Reset: 00 _H Timer 2 Mode Register	Bit Field	T2RE GS	T2RH EN	EDGE SEL	PREN	T2PRE		DCEN	
		Type	rw	rw	rw	rw	rw	rw	rw	
C2 _H	T21_RC2L Reset: 00 _H Timer 2 Reload/Capture Register Low	Bit Field	RC2							
		Type	rwh							
C3 _H	T21_RC2H Reset: 00 _H Timer 2 Reload/Capture Register High	Bit Field	RC2							
		Type	rwh							
C4 _H	T21_T2L Reset: 00 _H Timer 2 Register Low	Bit Field	THL2							
		Type	rwh							
C5 _H	T21_T2H Reset: 00 _H Timer 2 Register High	Bit Field	THL2							
		Type	rwh							
C6 _H	T21_T2CON1 Reset: 03 _H Timer 2 Control Register 1	Bit Field	0						TF2EN	EXF2E N
		Type	r						rw	rw

Functional Description
3.2.4.10 CCU6 Registers

The CCU6 SFRs can be accessed in the standard memory area (RMAP = 0).

Table 14 CCU6 Register Overview

Addr	Register Name	Bit	7	6	5	4	3	2	1	0
RMAP = 0										
A3 _H	CCU6_PAGE Page Register Reset: 00 _H	Bit Field	OP		STNR		0	PAGE		
		Type	w		w		r	rwh		
RMAP = 0, PAGE 0										
9A _H	CCU6_CC63SRL Capture/Compare Shadow Register for Channel CC63 Low Reset: 00 _H	Bit Field	CC63SL							
		Type	rw							
9B _H	CCU6_CC63SRH Capture/Compare Shadow Register for Channel CC63 High Reset: 00 _H	Bit Field	CC63SH							
		Type	rw							
9C _H	CCU6_TCTR4L Timer Control Register 4 Low Reset: 00 _H	Bit Field	T12 STD	T12 STR	0		DT RES	T12 RES	T12R S	T12R R
		Type	w	w	r		w	w	w	w
9D _H	CCU6_TCTR4H Timer Control Register 4 High Reset: 00 _H	Bit Field	T13 STD	T13 STR	0		T13 RES	T13R S	T13R R	
		Type	w	w	r		w	w	w	
9E _H	CCU6_MCMOUTSL Multi-Channel Mode Output Shadow Register Low Reset: 00 _H	Bit Field	STRM CM	0	MCMPS					
		Type	w	r	rw					
9F _H	CCU6_MCMOUTSH Multi-Channel Mode Output Shadow Register High Reset: 00 _H	Bit Field	STRH P	0	CURHS			EXPHS		
		Type	w	r	rw			rw		
A4 _H	CCU6_ISRL Capture/Compare Interrupt Status Reset Register Low Reset: 00 _H	Bit Field	RT12 PM	RT12 OM	RCC6 2F	RCC6 2R	RCC6 1F	RCC6 1R	RCC6 0F	RCC6 0R
		Type	w	w	w	w	w	w	w	w
A5 _H	CCU6_ISRH Capture/Compare Interrupt Status Reset Register High Reset: 00 _H	Bit Field	RSTR	RIDLE	RWH E	RCHE	0	RTRP F	RT13 PM	RT13 CM
		Type	w	w	w	w	r	w	w	w
A6 _H	CCU6_CMPMODIFL Compare State Modification Register Low Reset: 00 _H	Bit Field	0	MCC6 3S	0			MCC6 2S	MCC6 1S	MCC6 0S
		Type	r	w	r			w	w	w
A7 _H	CCU6_CMPMODIFH Compare State Modification Register High Reset: 00 _H	Bit Field	0	MCC6 3R	0			MCC6 2R	MCC6 1R	MCC6 0R
		Type	r	w	r			w	w	w
FA _H	CCU6_CC60SRL Capture/Compare Shadow Register for Channel CC60 Low Reset: 00 _H	Bit Field	CC60SL							
		Type	rwh							
FB _H	CCU6_CC60SRH Capture/Compare Shadow Register for Channel CC60 High Reset: 00 _H	Bit Field	CC60SH							
		Type	rwh							

Functional Description
Table 14 CCU6 Register Overview (cont'd)

Addr	Register Name	Bit	7	6	5	4	3	2	1	0
FC _H	CCU6_CC61SRL Reset: 00_H Capture/Compare Shadow Register for Channel CC61 Low	Bit Field	CC61SL							
		Type	rwh							
FD _H	CCU6_CC61SRH Reset: 00_H Capture/Compare Shadow Register for Channel CC61 High	Bit Field	CC61SH							
		Type	rwh							
FE _H	CCU6_CC62SRL Reset: 00_H Capture/Compare Shadow Register for Channel CC62 Low	Bit Field	CC62SL							
		Type	rwh							
FF _H	CCU6_CC62SRH Reset: 00_H Capture/Compare Shadow Register for Channel CC62 High	Bit Field	CC62SH							
		Type	rwh							
RMAP = 0, PAGE 1										
9A _H	CCU6_CC63RL Reset: 00_H Capture/Compare Register for Channel CC63 Low	Bit Field	CC63VL							
		Type	rh							
9B _H	CCU6_CC63RH Reset: 00_H Capture/Compare Register for Channel CC63 High	Bit Field	CC63VH							
		Type	rh							
9C _H	CCU6_T12PRL Reset: 00_H Timer T12 Period Register Low	Bit Field	T12PVL							
		Type	rwh							
9D _H	CCU6_T12PRH Reset: 00_H Timer T12 Period Register High	Bit Field	T12PVH							
		Type	rwh							
9E _H	CCU6_T13PRL Reset: 00_H Timer T13 Period Register Low	Bit Field	T13PVL							
		Type	rwh							
9F _H	CCU6_T13PRH Reset: 00_H Timer T13 Period Register High	Bit Field	T13PVH							
		Type	rwh							
A4 _H	CCU6_T12DTCL Reset: 00_H Dead-Time Control Register for Timer T12 Low	Bit Field	DTM							
		Type	rw							
A5 _H	CCU6_T12DTCH Reset: 00_H Dead-Time Control Register for Timer T12 High	Bit Field	0	DTR2	DTR1	DTR0	0	DTE2	DTE1	DTE0
		Type	r	rh	rh	rh	r	rw	rw	rw
A6 _H	CCU6_TCTR0L Reset: 00_H Timer Control Register 0 Low	Bit Field	CTM	CDIR	STE1 2	T12R	T12 PRE	T12CLK		
		Type	rw	rh	rh	rh	rw	rw		
A7 _H	CCU6_TCTR0H Reset: 00_H Timer Control Register 0 High	Bit Field	0	STE1 3	T13R	T13 PRE	T13CLK			
		Type	r	rh	rh	rw	rw			
FA _H	CCU6_CC60RL Reset: 00_H Capture/Compare Register for Channel CC60 Low	Bit Field	CC60VL							
		Type	rh							
FB _H	CCU6_CC60RH Reset: 00_H Capture/Compare Register for Channel CC60 High	Bit Field	CC60VH							
		Type	rh							
FC _H	CCU6_CC61RL Reset: 00_H Capture/Compare Register for Channel CC61 Low	Bit Field	CC61VL							
		Type	rh							

Functional Description
Table 14 CCU6 Register Overview (cont'd)

Addr	Register Name	Bit	7	6	5	4	3	2	1	0
FD _H	CCU6_CC61RH Reset: 00_H Capture/Compare Register for Channel CC61 High	Bit Field	CC61VH							
		Type	rh							
FE _H	CCU6_CC62RL Reset: 00_H Capture/Compare Register for Channel CC62 Low	Bit Field	CC62VL							
		Type	rh							
FF _H	CCU6_CC62RH Reset: 00_H Capture/Compare Register for Channel CC62 High	Bit Field	CC62VH							
		Type	rh							
RMAP = 0, PAGE 2										
9A _H	CCU6_T12MSELL Reset: 00_H T12 Capture/Compare Mode Select Register Low	Bit Field	MSEL61				MSEL60			
		Type	rw				rw			
9B _H	CCU6_T12MSELH Reset: 00_H T12 Capture/Compare Mode Select Register High	Bit Field	DBYP	HSYNC			MSEL62			
		Type	rw	rw			rw			
9C _H	CCU6_IENL Reset: 00_H Capture/Compare Interrupt Enable Register Low	Bit Field	ENT1 2 PM	ENT1 2 OM	ENCC 62F	ENCC 62R	ENCC 61F	ENCC 61R	ENCC 60F	ENCC 60R
		Type	rw	rw	rw	rw	rw	rw	rw	rw
9D _H	CCU6_IENH Reset: 00_H Capture/Compare Interrupt Enable Register High	Bit Field	EN STR	EN IDLE	EN WHE	EN CHE	0	EN TRPF	ENT1 3PM	ENT1 3CM
		Type	rw	rw	rw	rw	r	rw	rw	rw
9E _H	CCU6_INPL Reset: 40_H Capture/Compare Interrupt Node Pointer Register Low	Bit Field	INPCHE		INPCC62		INPCC61		INPCC60	
		Type	rw		rw		rw		rw	
9F _H	CCU6_INPH Reset: 39_H Capture/Compare Interrupt Node Pointer Register High	Bit Field	0	INPT13		INPT12		INPERR		
		Type	r	rw		rw		rw		
A4 _H	CCU6_ISSL Reset: 00_H Capture/Compare Interrupt Status Set Register Low	Bit Field	ST12 PM	ST12 OM	SCC6 2F	SCC6 2R	SCC6 1F	SCC6 1R	SCC6 0F	SCC6 0R
		Type	w	w	w	w	w	w	w	w
A5 _H	CCU6_ISSH Reset: 00_H Capture/Compare Interrupt Status Set Register High	Bit Field	SSTR	SIDLE	SWHE	SCHE	SWH C	STRP F	ST13 PM	ST13 CM
		Type	w	w	w	w	w	w	w	w
A6 _H	CCU6_PSLR Reset: 00_H Passive State Level Register	Bit Field	PSL63	0	PSL					
		Type	rwh	r	rwh					
A7 _H	CCU6_MCMCTR Reset: 00_H Multi-Channel Mode Control Register	Bit Field	0		SWSYN		0	SWSEL		
		Type	r		rw		r	rw		
FA _H	CCU6_TCTR2L Reset: 00_H Timer Control Register 2 Low	Bit Field	0	T13TED		T13TEC			T13 SSC	T12 SSC
		Type	r	rw		rw			rw	rw
FB _H	CCU6_TCTR2H Reset: 00_H Timer Control Register 2 High	Bit Field	0				T13RSEL		T12RSEL	
		Type	r				rw		rw	
FC _H	CCU6_MODCTRL Reset: 00_H Modulation Control Register Low	Bit Field	MCM EN	0	T12MODEN					
		Type	rw	r	rw					

Functional Description
Table 14 CCU6 Register Overview (cont'd)

Addr	Register Name	Bit	7	6	5	4	3	2	1	0	
FD _H	CCU6_MODCTR_H Reset: 00 _H Modulation Control Register High	Bit Field	ECT1 30	0	T13MODEN						
		Type	rw	r	rw						
FE _H	CCU6_TRPCTRL Reset: 00 _H Trap Control Register Low	Bit Field	0					TRPM 2	TRPM 1	TRPM 0	
		Type	r					rw	rw	rw	
FF _H	CCU6_TRPCTR_H Reset: 00 _H Trap Control Register High	Bit Field	TRPP EN	TRPE N13	TRPEN						
		Type	rw	rw	rw						
RMAP = 0, PAGE 3											
9A _H	CCU6_MCMOUTL Reset: 00 _H Multi-Channel Mode Output Register Low	Bit Field	0	R	MCMP						
		Type	r	rh	rh						
9B _H	CCU6_MCMOUTH Reset: 00 _H Multi-Channel Mode Output Register High	Bit Field	0		CURH			EXPH			
		Type	r		rh			rh			
9C _H	CCU6_ISL Reset: 00 _H Capture/Compare Interrupt Status Register Low	Bit Field	T12 PM	T12 OM	ICC62 F	ICC62 R	ICC61 F	ICC61 R	ICC60 F	ICC60 R	
		Type	rh	rh	rh	rh	rh	rh	rh	rh	
9D _H	CCU6_ISH Reset: 00 _H Capture/Compare Interrupt Status Register High	Bit Field	STR	IDLE	WHE	CHE	TRPS	TRPF	T13 PM	T13 CM	
		Type	rh	rh	rh	rh	rh	rh	rh	rh	
9E _H	CCU6_PISEL0L Reset: 00 _H Port Input Select Register 0 Low	Bit Field	ISTRP		ISCC62		ISCC61		ISCC60		
		Type	rw		rw		rw		rw		
9F _H	CCU6_PISEL0H Reset: 00 _H Port Input Select Register 0 High	Bit Field	IST12HR		ISPOS2		ISPOS1		ISPOS0		
		Type	rw		rw		rw		rw		
A4 _H	CCU6_PISEL2 Reset: 00 _H Port Input Select Register 2	Bit Field	0						IST13HR		
		Type	r						rw		
FA _H	CCU6_T12L Reset: 00 _H Timer T12 Counter Register Low	Bit Field	T12CVL								
		Type	rwh								
FB _H	CCU6_T12H Reset: 00 _H Timer T12 Counter Register High	Bit Field	T12CVH								
		Type	rwh								
FC _H	CCU6_T13L Reset: 00 _H Timer T13 Counter Register Low	Bit Field	T13CVL								
		Type	rwh								
FD _H	CCU6_T13H Reset: 00 _H Timer T13 Counter Register High	Bit Field	T13CVH								
		Type	rwh								
FE _H	CCU6_CMPSTATL Reset: 00 _H Compare State Register Low	Bit Field	0	CC63 ST	CC POS2	CC POS1	CC POS0	CC62 ST	CC61 ST	CC60 ST	
		Type	r	rh	rh	rh	rh	rh	rh	rh	
FF _H	CCU6_CMPSTATH Reset: 00 _H Compare State Register High	Bit Field	T13IM	COU T63PS	COU T62PS	CC62 PS	COU T61PS	CC61 PS	COU T60PS	CC60 PS	
		Type	rwh	rwh	rwh	rwh	rwh	rwh	rwh	rwh	

Functional Description
3.2.4.11 UART1 Registers

The UART1 SFRs can be accessed in the mapped memory area (RMAP = 1).

Table 15 UART1 Register Overview

Addr	Register Name	Bit	7	6	5	4	3	2	1	0
RMAP = 1										
C8 _H	SCON Reset: 00_H Serial Channel Control Register	Bit Field	SM0	SM1	SM2	REN	TB8	RB8	TI	RI
		Type	rw	rw	rw	rw	rw	rwh	rwh	rwh
C9 _H	SBUF Reset: 00_H Serial Data Buffer Register	Bit Field	VAL							
		Type	rwh							
CA _H	BCON Reset: 00_H Baud Rate Control Register	Bit Field	0			BRPRE			R	
		Type	r			rw			rw	
CB _H	BG Reset: 00_H Baud Rate Timer/Reload Register	Bit Field	BR_VALUE							
		Type	rwh							
CC _H	FDCON Reset: 00_H Fractional Divider Control Register	Bit Field	0				NDOV	FDM	FDEN	
		Type	r				rwh	rw	rw	
CD _H	FDSTEP Reset: 00_H Fractional Divider Reload Register	Bit Field	STEP							
		Type	rw							
CE _H	FDRES Reset: 00_H Fractional Divider Result Register	Bit Field	RESULT							
		Type	rh							
CF _H	SCON1 Reset: 07_H Serial Channel Control Register 1	Bit Field	0				NDOV EN	TIEN	RIEN	
		Type	r				rwh	rw	rw	

3.2.4.12 SSC Registers

The SSC SFRs can be accessed in the standard memory area (RMAP = 0).

Table 16 SSC Register Overview

Addr	Register Name	Bit	7	6	5	4	3	2	1	0
RMAP = 0										
A9 _H	SSC_PISEL Reset: 00_H Port Input Select Register	Bit Field	0				CIS	SIS	MIS	
		Type	r				rw	rw	rw	
AA _H	SSC_CONL Reset: 00_H Control Register Low Programming Mode	Bit Field	LB	PO	PH	HB	BM			
		Type	rw	rw	rw	rw	rw			
AA _H	SSC_CONL Reset: 00_H Control Register Low Operating Mode	Bit Field	0				BC			
		Type	r				rh			
AB _H	SSC_CONH Reset: 00_H Control Register High Programming Mode	Bit Field	EN	MS	0	AREN	BEN	PEN	REN	TEN
		Type	rw	rw	r	rw	rw	rw	rw	rw

Functional Description
Table 16 SSC Register Overview (cont'd)

Addr	Register Name	Bit	7	6	5	4	3	2	1	0
AB _H	SSC_CONH Reset: 00 _H Control Register High Operating Mode	Bit Field	EN	MS	0	BSY	BE	PE	RE	TE
		Type	rw	rw	r	rh	rwh	rwh	rwh	rwh
AC _H	SSC_TBL Reset: 00 _H Transmitter Buffer Register Low	Bit Field	TB_VALUE							
		Type	rw							
AD _H	SSC_RBL Reset: 00 _H Receiver Buffer Register Low	Bit Field	RB_VALUE							
		Type	rh							
AE _H	SSC_BRL Reset: 00 _H Baud Rate Timer Reload Register Low	Bit Field	BR_VALUE							
		Type	rw							
AF _H	SSC_BRH Reset: 00 _H Baud Rate Timer Reload Register High	Bit Field	BR_VALUE							
		Type	rw							

3.2.4.13 MultiCAN Registers

The MultiCAN SFRs can be accessed in the standard memory area (RMAP = 0).

Table 17 CAN Register Overview

Addr	Register Name	Bit	7	6	5	4	3	2	1	0
RMAP = 0										
D8 _H	ADCON Reset: 00 _H CAN Address/Data Control Register	Bit Field	V3	V2	V1	V0	AUAD		BSY	RWEN
		Type	rw	rw	rw	rw	rw		rh	rw
D9 _H	ADL Reset: 00 _H CAN Address Register Low	Bit Field	CA9	CA8	CA7	CA6	CA5	CA4	CA3	CA2
		Type	rwh	rwh	rwh	rwh	rwh	rwh	rwh	rwh
DA _H	ADH Reset: 00 _H CAN Address Register High	Bit Field	0				CA13	CA12	CA11	CA10
		Type	r				rwh	rwh	rwh	rwh
DB _H	DATA0 Reset: 00 _H CAN Data Register 0	Bit Field	CD							
		Type	rwh							
DC _H	DATA1 Reset: 00 _H CAN Data Register 1	Bit Field	CD							
		Type	rwh							
DD _H	DATA2 Reset: 00 _H CAN Data Register 2	Bit Field	CD							
		Type	rwh							
DE _H	DATA3 Reset: 00 _H CAN Data Register 3	Bit Field	CD							
		Type	rwh							

3.2.4.14 OCDS Registers

The OCDS SFRs can be accessed in the mapped memory area (RMAP = 1).

Functional Description
Table 18 OCDS Register Overview

Addr	Register Name	Bit	7	6	5	4	3	2	1	0
RMAP = 1										
E9 _H	MMCR2 Monitor Mode Control 2 Register Reset: 8U_H	Bit Field	STMO DE	EXBC	DSUS P	MBCO N	ALTDI	MMEP	MMOD E	JENA
		Type	rw	rw	rw	rwh	rw	rwh	rh	rh
EA _H	MEXTCR Memory Extension Control Register Reset: 0U_H	Bit Field	0				BANKBPx			
		Type	r				rw			
EB _H	MMWR1 Monitor Work Register 1 Reset: 00_H	Bit Field	MMWR1							
		Type	rw							
EC _H	MMWR2 Monitor Work Register 2 Reset: 00_H	Bit Field	MMWR2							
		Type	rw							
F1 _H	MMCR Monitor Mode Control Register Reset: 00_H	Bit Field	MEXIT _P	MEXIT	0	MSTE P	MRAM S_P	MRAM S	TRF	RRF
		Type	w	rwh	r	rw	w	rwh	rh	rh
F2 _H	MMSR Monitor Mode Status Register Reset: 00_H	Bit Field	MBCA M	MBCIN	EXBF	SWBF	HWB3 F	HWB2 F	HWB1 F	HWB0 F
		Type	rw	rwh	rwh	rwh	rwh	rwh	rwh	rwh
F3 _H	MMBPCR Breakpoints Control Register Reset: 00_H	Bit Field	SWBC	HWB3C		HWB2C		HWB1 C	HWB0C	
		Type	rw	rw		rw		rw	rw	
F4 _H	MMICR Monitor Mode Interrupt Control Register Reset: 00_H	Bit Field	DVEC T	DRET R	COMR ST	MSTS EL	MMUI E_P	MMUI E	RRIE_ P	RRIE
		Type	rwh	rwh	rwh	rh	w	rw	w	rw
F5 _H	MMDR Monitor Mode Data Transfer Register Receive Reset: 00_H	Bit Field	MMRR							
		Type	rh							
F6 _H	HWBPSR Hardware Breakpoints Select Register Reset: 00_H	Bit Field	0			BPSEL _P	BPSEL			
		Type	r			w	rw			
F7 _H	HWBPDR Hardware Breakpoints Data Register Reset: 00_H	Bit Field	HWBPxx							
		Type	rw							

3.2.4.15 Flash Registers

The Flash SFRs can be accessed in the mapped memory area (RMAP = 1).

Table 19 Flash Register Overview

Addr	Register Name	Bit	7	6	5	4	3	2	1	0
RMAP = 1										
D1 _H	FCON Reset: 10_H P-Flash Control Register	Bit Field	0	FBSY	YE	1	NVST R	MAS1	ERAS E	PROG
		Type	r	rh	rwh	r	rw	rw	rw	rw
D2 _H	EECON Reset: 10_H D-Flash Control Register	Bit Field	0	EEBS Y	YE	1	NVST R	MAS1	ERAS E	PROG
		Type	r	rh	rwh	r	rw	rw	rw	rw
D3 _H	FCS Reset: 80_H Flash Control and Status Register	Bit Field	1	SBEIE	FTEN	0	EEDE RR	EESE RR	FDER R	FSER R
		Type	r	rw	rwh	r	rwh	rwh	rwh	rwh
D4 _H	FEAL Reset: 00_H Flash Error Address Register, Low Byte	Bit Field	ECCEADDR							
		Type	rh							
D5 _H	FEAH Reset: 00_H Flash Error Address Register, High Byte	Bit Field	ECCEADDR							
		Type	rh							
D6 _H	FTVAL Reset: 78_H Flash Timer Value Register	Bit Field	MODE	OFVAL						
		Type	rw	rw						
DD _H	FCS1 Reset: 00_H Flash Control and Status Register 1	Bit Field	0							EEAB ORT
		Type	r							rwh

3.3 Flash Memory

The Flash memory provides an embedded user-programmable non-volatile memory, allowing fast and reliable storage of user code and data. It is operated from a single 2.5 V supply from the Embedded Voltage Regulator (EVR) and does not require additional programming or erasing voltage. The pagination of the Flash memory allows each page to be erased independently.

Features

- In-System Programming (ISP) via UART
- In-Application Programming (IAP)
- Error Correction Code (ECC) for dynamic correction of single-bit errors
- Background program and erase operations for CPU load minimization
- Support for aborting erase operation
- Minimum program width
 - of 1-byte for D-Flash and 2-bytes for P-Flash
- 1-page minimum erase width
- 1-byte read access
- Flash is delivered in erased state (read all ones)
- Operating supply voltage: 2.5 V \pm 7.5 %
- Read access time: $1 \times t_{\text{CCLK}} = 38 \text{ ns}^1$
- Program time for 1 wordline: 1.6 ms²
- Page erase time: 20 ms
- Mass erase time: 200 ms

1) Values shown here are typical values. $f_{\text{sys}} = 144 \text{ MHz} \pm 7.5\%$ ($f_{\text{CCLK}} = 24 \text{ MHz} \pm 7.5\%$) is the maximum frequency range for Flash read access.

2) Values shown here are typical values. $f_{\text{sys}} = 144 \text{ MHz} \pm 7.5\%$ ($f_{\text{CCLK}} = 24 \text{ MHz} \pm 7.5\%$) is the typical frequency range for Flash programming and erasing. f_{sysmin} is used for obtaining the worst case timing.

Functional Description

Table 20 and **Table 21** shows the Flash data retention and endurance targets for Industrial profile and Automotive profile respectively.

Table 20 Flash Data Retention and Endurance for Industrial Profile (Operating Conditions apply)

Retention	Endurance ¹⁾²⁾	Size	Remarks
Program Flash			
15 years	1000 cycles	up to 60 Kbytes	
Data Flash			
15 years	1000 cycles	4 Kbytes	
10 years	10,000 cycles	4 Kbytes	
5 years	30,000 cycles	4 Kbytes	
1 year	100,000 cycles	4 Kbytes	SAF and SAX variant
	80,000 cycles		SAK variant

1) In Program Flash, one cycle refers to the programming of all pages in the flash bank and a mass erase.

2) In Data Flash, one cycle refers to the programming of all wordlines in a page and a page erase.

Table 21 Flash Data Retention and Endurance for Automotive Profile (Operating Conditions apply)

Retention	Endurance ¹⁾²⁾	Size	Remarks
Program Flash			
15 years	1000 cycles	up to 60 Kbytes	
Data Flash			
15 years	1000 cycles	4 Kbytes	
5 years	10,000 cycles	1 Kbytes	
2 years	15,000 cycles	512 Bytes	
2 years	30,000 cycles	256 Bytes	
1 year	100,000 cycles	128 Bytes	

1) In Program Flash, one cycle refers to the programming of all pages in the flash bank and a mass erase.

2) In Data Flash, one cycle refers to the programming of all wordlines in a page and a page erase.

3.3.1 Flash Bank Pagination

The XC87x product family offers Flash devices with either 64 Kbytes or 52 Kbytes of embedded Flash memory. Each Flash device consists of a Program Flash (P-Flash) and a single Data Flash (D-Flash) bank. P-Flash has 120 pages of 8 wordlines per page with 64 bytes per wordline. D-Flash has 64 pages of 2 wordlines per page with 32 bytes per wordline. Both types can be used for code and data storage.. The label “Data” neither implies that the D-Flash is mapped to the data memory region, nor that it can only be used for data storage. It is used to distinguish the different page width and wordline of each Flash bank.

The internal structure of each Flash bank represents a page architecture for flexible erase capability. The minimum erase width is always a complete page. The D-Flash bank is divided into smaller size for extended erasing and reprogramming capability; even numbers for each page size are provided to allow greater flexibility and the ability to adapt to a wide range of application requirements.

3.4 Interrupt System

The XC800 Core supports one non-maskable interrupt (NMI) and 14 maskable interrupt requests. In addition to the standard interrupt functions supported by the core, e.g., configurable interrupt priority and interrupt masking, the XC87x interrupt system provides extended interrupt support capabilities such as the mapping of each interrupt vector to several interrupt sources to increase the number of interrupt sources supported, and additional status registers for detecting and determining the interrupt source.

3.4.1 Interrupt Source

Figure 12 to Figure 16 give a general overview of the interrupt sources and nodes, and their corresponding control and status flags.



Figure 12 Non-Maskable Interrupt Request Sources

Functional Description



Figure 13 Interrupt Request Sources (Part 1)

Functional Description



Figure 14 Interrupt Request Sources (Part 2)

Functional Description



Figure 15 Interrupt Request Sources (Part 3)

Functional Description



Figure 16 Interrupt Request Sources (Part 4)

Functional Description



Figure 17 Interrupt Request Sources (Part 5)

3.4.2 Interrupt Source and Vector

Each interrupt event source has an associated interrupt vector address for the interrupt node it belongs to. This vector is accessed to service the corresponding interrupt node request. The interrupt service of each interrupt source can be individually enabled or disabled via an enable bit. The assignment of the XC87x interrupt sources to the interrupt vector address and the corresponding interrupt node enable bits are summarized in [Table 22](#).

Table 22 Interrupt Vector Addresses

Interrupt Source	Vector Address	Assignment for XC87x	Enable Bit	SFR
NMI	0073 _H	Watchdog Timer NMI	NMIWDT	NMICON
		PLL NMI	NMIPLL	
		Flash Timer NMI	NMIFLASH	
		V _{DDP} Prewarning NMI	NMIVDDP	
		Flash ECC NMI	NMIECC	
XINTR0	0003 _H	External Interrupt 0	EX0	IEN0
XINTR1	000B _H	Timer 0	ET0	
XINTR2	0013 _H	External Interrupt 1	EX1	
XINTR3	001B _H	Timer 1	ET1	
XINTR4	0023 _H	UART	ES	
XINTR5	002B _H	T2CCU	ET2	
		UART Fractional Divider (Normal Divider Overflow)		
		MultiCAN Node 0		
		LIN		

Functional Description
Table 22 Interrupt Vector Addresses (cont'd)

Interrupt Source	Vector Address	Assignment for XC87x	Enable Bit	SFR
XINTR6	0033 _H	MultiCAN Nodes 1 and 2	EADC	IEN1
		ADC[1:0]		
XINTR7	003B _H	SSC	ESSC	
XINTR8	0043 _H	External Interrupt 2	EX2	
		T21		
		CORDIC		
		UART1		
		UART1 Fractional Divider (Normal Divider Overflow)		
		MDU[1:0]		
XINTR9	004B _H	External Interrupt 3	EXM	
		External Interrupt 4		
		External Interrupt 5		
		External Interrupt 6		
		T2CCU		
		MultiCAN Node 3		
XINTR10	0053 _H	CCU6 INP0	ECCIP0	
		MultiCAN Node 4		
XINTR11	005B _H	CCU6 INP1	ECCIP1	
		MultiCAN Node 5		
XINTR12	0063 _H	CCU6 INP2	ECCIP2	
		MultiCAN Node 6		
XINTR13	006B _H	CCU6 INP3	ECCIP3	
		MultiCAN Node 7		

3.4.3 Interrupt Priority

An interrupt that is currently being serviced can only be interrupted by a higher-priority interrupt, but not by another interrupt of the same or lower priority. Hence, an interrupt of the highest priority cannot be interrupted by any other interrupt request.

If two or more requests of different priority levels are received simultaneously, the request of the highest priority is serviced first. If requests of the same priority are received simultaneously, then an internal polling sequence determines which request is serviced first. Thus, within each priority level, there is a second priority structure determined by the polling sequence shown in [Table 23](#).

Table 23 Priority Structure within Interrupt Level

Source	Level
Non-Maskable Interrupt (NMI)	(highest)
External Interrupt 0	1
Timer 0 Interrupt	2
External Interrupt 1	3
Timer 1 Interrupt	4
UART Interrupt	5
T2CCU, UART Normal Divider Overflow, MultiCAN, LIN Interrupt	6
ADC, MultiCAN Interrupt	7
SSC Interrupt	8
External Interrupt 2, Timer 21, UART1, UART1 Normal Divider Overflow, MDU, CORDIC Interrupt	9
External Interrupt [6:3], MultiCAN Interrupt	10
CCU6 Interrupt Node Pointer 0, MultiCAN interrupt	11
CCU6 Interrupt Node Pointer 1, MultiCAN Interrupt	12
CCU6 Interrupt Node Pointer 2, MultiCAN Interrupt	13
CCU6 Interrupt Node Pointer 3, MultiCAN Interrupt	14

3.5 Parallel Ports

The XC87x has 40 port pins organized into five parallel ports: Port 0 (P0), Port 1 (P1), Port 3 (P3), Port 4 (P4) and Port 5 (P5). Each pin has a pair of internal pull-up and pull-down devices that can be individually enabled or disabled. These ports are bidirectional and can be used as general purpose input/output (GPIO) or to perform alternate input/output functions for the on-chip peripherals. When configured as an output, the open drain mode can be selected.

Bidirectional Port Features

- Configurable pin direction
- Configurable pull-up/pull-down devices
- Configurable open drain mode
- Configurable drive strength
- Transfer of data through digital inputs and outputs (general purpose I/O)
- Alternate input/output for on-chip peripherals

Functional Description

Figure 18 shows the structure of a bidirectional port pin.



Figure 18 General Structure of Bidirectional Port

3.6 Power Supply System with Embedded Voltage Regulator

The XC87x microcontroller requires two different levels of power supply:

- 3.3 V or 5.0 V for the Embedded Voltage Regulator (EVR) and Ports
- 2.5 V for the core, memory, on-chip oscillator, and peripherals

Figure 19 shows the XC87x power supply system. A power supply of 3.3 V or 5.0 V must be provided from the external power supply pin. The 2.5 V power supply for the logic is generated by the EVR. The EVR helps to reduce the power consumption of the whole chip and the complexity of the application board design.

The EVR consists of a main voltage regulator and a low power voltage regulator. In active mode, both voltage regulators are enabled. In power-down mode¹⁾, the main voltage regulator is switched off, while the low power voltage regulator continues to function and provide power supply to the system with low power consumption.



Figure 19 XC87x Power Supply System

EVR Features

- Input voltage (V_{DDP}): 3.3 V/5.0 V
- Output voltage (V_{DDC}): 2.5 V \pm 7.5%
- Low power voltage regulator provided in power-down mode¹⁾
- V_{DDP} prewarning detection
- V_{DDC} brownout detection

1) SAK product variant does not support power-down mode.

3.7 Reset Control

The XC87x has five types of reset: power-on reset, hardware reset, watchdog timer reset, power-down wake-up reset, and brownout reset.

When the XC87x is first powered up, the status of certain pins (see [Table 25](#)) must be defined to ensure proper start operation of the device. At the end of a reset sequence, the sampled values are latched to select the desired boot option, which cannot be modified until the next power-on reset or hardware reset. This guarantees stable conditions during the normal operation of the device.

The second type of reset in XC87x is the hardware reset. This reset function can be used during normal operation or when the chip is in power-down mode. A reset input pin RESET is provided for the hardware reset.

The Watchdog Timer (WDT) module is also capable of resetting the device if it detects a malfunction in the system.

Another type of reset that needs to be detected is a reset while the device is in power-down mode (wake-up reset). While the contents of the static RAM are undefined after a power-on reset, they are well defined after a wake-up reset from power-down mode.

3.7.1 Module Reset Behavior

[Table 24](#) lists the functions of the XC87x and the various reset types that affect these functions. The symbol “■” signifies that the particular function is reset to its default state.

Table 24 Effect of Reset on Device Functions

Module/ Function	Wake-Up Reset	Watchdog Reset	Hardware Reset	Power-On Reset	Brownout Reset
CPU Core	■	■	■	■	■
Peripherals	■	■	■	■	■
On-Chip Static RAM	Not affected, Reliable	Not affected, Reliable	Not affected, Reliable	Affected, un- reliable	Affected, un- reliable
Oscillator, PLL	■	Not affected	■	■	■
Port Pins	■	■	■	■	■
EVR	The voltage regulator is switched on	Not affected	Not affected	■	■
FLASH	■	■	■	■	■
NMI	Disabled	Disabled	■	■	■

3.7.2 Booting Scheme

When the XC87x is reset, it must identify the type of configuration with which to start the different modes once the reset sequence is complete. Thus, boot configuration information that is required for activation of special modes and conditions needs to be applied by the external world through input pins. After power-on reset or hardware reset, the pins MBC, TMS and P0.0 collectively select the different boot options. **Table 25** shows the available boot options in the XC87x.

Table 25 XC87x Boot Selection ¹⁾

MBC	TMS	P0.0	Type of Mode	PC Start Value
1	0	X	User Mode ²⁾ ; on-chip OSC/PLL non-bypassed	0000 _H
0	0	X	BSL Mode; (LIN Mode ³⁾ , UART/ MultiCAN Mode ⁴⁾⁵⁾ and Alternate BSL Mode ⁶⁾); on-chip OSC/PLL non-bypassed	0000 _H
0	1	0	OCDS Mode; on-chip OSC/PLL non-bypassed	0000 _H
1	1	0	User (JTAG) Mode ⁷⁾ ; on-chip OSC/PLL non-bypassed (normal)	0000 _H

1) In addition to the pins MBC, TMS and P0.0, TM pin also requires an external pull down for all the boot options.

2) BSL mode is automatically entered if no valid password is installed and data at memory address 0000H equals zero.

3) If a device is programmed as LIN, LIN BSL is always used instead of UART/MultiCAN.

4) UART or MultiCAN BSL is decoded by firmware based on the protocol for product variant with MultiCAN. If no MultiCAN and LIN variant, UART BSL is used.

5) In MultiCAN BSL mode, the clock source is switched to XTAL by firmware, bypassing the on-chip oscillator. This avoids any frequency invariance with the on-chip oscillator and allows other frequency clock input, thus ensuring accurate baud rate detection (especially at high bit rates).

6) Alternate BSL Mode is a user defined BSL code programmed in Flash. It is entered if the AltBSLPassword is valid.

7) Normal user mode with standard JTAG (TCK,TDI,TDO) pins for hot-attach purpose.

Note: The boot options are valid only with the default set of UART and JTAG pins.

3.8 Clock Generation Unit

The Clock Generation Unit (CGU) allows great flexibility in the clock generation for the XC87x. The power consumption is indirectly proportional to the frequency, whereas the performance of the microcontroller is directly proportional to the frequency. During user program execution, the frequency can be programmed for an optimal ratio between performance and power consumption. Therefore the power consumption can be adapted to the actual application state.

Features

- Phase-Locked Loop (PLL) for multiplying clock source by different factors
- PLL Base Mode
- Prescaler Mode
- PLL Mode
- Power-down mode support¹⁾

The CGU consists of an oscillator circuit and a PLL. In the XC87x, the oscillator can be from either of these two sources: the on-chip oscillator (4 MHz) or the external oscillator (2 MHz to 20 MHz). The term “oscillator” is used to refer to both on-chip oscillator and external oscillator, unless otherwise stated. After the reset, the on-chip oscillator will be used by default. The external oscillator can be selected via software. In addition, the PLL provides a fail-safe logic to perform oscillator run and loss-of-lock detection. This allows emergency routines to be executed for system recovery or to perform system shut down.

1) SAK product variant does not support power-down mode.



Figure 20 CGU Block Diagram

Direct Drive (PLL Bypass Operation)

During PLL bypass operation, the system clock has the same frequency as the external clock source.

$$(3.1)$$

$$f_{\text{SYS}} = f_{\text{OSC}}$$

PLL Mode

The CPU clock is derived from the oscillator clock, divided by the NR factor (PDIV), multiplied by the NF factor (NDIV), and divided by the OD factor (KDIV). PLL output must

Functional Description

not be bypassed for this PLL mode. The PLL mode is used during normal system operation.

(3.2)

$$f_{\text{SYS}} = f_{\text{OSC}} \times \frac{\text{NF}}{\text{NR} \times \text{OD}}$$

System Frequency Selection

For the XC87x, the value of NF, NR and OD can be selected by bits NDIV, PDIV and KDIV respectively for different oscillator inputs in order to obtain the required f_{sys} . But the combination of these factors must fulfill the following condition:

- $100 \text{ MHz} < f_{\text{VCO}} < 175 \text{ MHz}$
- $800 \text{ KHz} < f_{\text{OSC}} / (2 * \text{NR}) < 8 \text{ MHz}$

Table 26 provides examples on how the typical system frequency of $f_{\text{sys}} = 144 \text{ MHz}$ and maximum frequency of 160 MHz (CPU clock = 26.67 MHz) can be obtained for the different oscillator sources.

Table 26 System frequency ($f_{\text{sys}} = 144 \text{ MHz}$)

Oscillator	fosc	N	P	K	f _{sys}
On-chip	4 MHz	72	2	1	144 MHz
	4 MHz	80	2	1	160 MHz
External	8 MHz	72	4	1	144 MHz
	6 MHz	72	3	1	144 MHz
	4 MHz	72	2	1	144 MHz

3.8.1 Recommended External Oscillator Circuits

The oscillator circuit, a Pierce oscillator, is designed to work with both, an external crystal oscillator or an external stable clock source. It basically consists of an inverting amplifier and a feedback element with XTAL1 as input, and XTAL2 as output.

When using a crystal, a proper external oscillator circuitry must be connected to both pins, XTAL1 and XTAL2. The crystal frequency can be within the range of 2 MHz to 20 MHz . Additionally, it is necessary to have two load capacitances C_{X1} and C_{X2} , and depending on the crystal type, a series resistor R_{X2} , to limit the current. A test resistor R_Q may be temporarily inserted to measure the oscillation allowance (negative resistance) of the oscillator circuitry. R_Q values are typically specified by the crystal vendor. An external feedback resistor R_f is also required in the external oscillator circuitry. The exact values and related operating range are dependent on the crystal frequency and have to be determined and optimized together with the crystal vendor using the negative

Functional Description

resistance method. Oscillation measurement with the final target system is strongly recommended to verify the input amplitude at XTAL1 and to determine the actual oscillation allowance (margin negative resistance) for the oscillator-crystal system.

When using an external clock signal, the signal must be connected to XTAL1. XTAL2 is left open (unconnected).

The oscillator can also be used in combination with a ceramic resonator. The final circuitry must also be verified by the resonator vendor. **Figure 21** shows the recommended external oscillator circuitries for both operating modes, external crystal mode and external input clock mode.

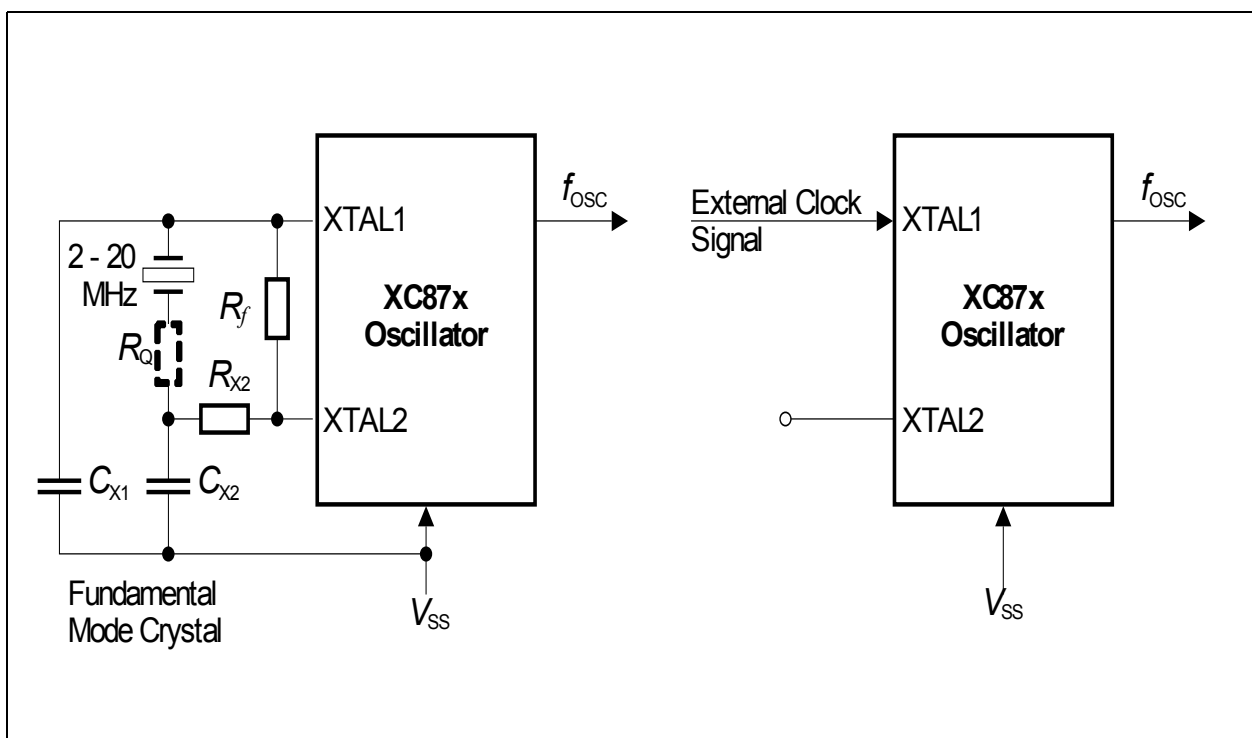

Figure 21 External Oscillator Circuitry

Note: For crystal operation, it is strongly recommended to measure the negative resistance in the final target system (layout) to determine the optimum parameters for the oscillator operation. Please refer to the minimum and maximum values of the negative resistance specified by the crystal supplier.

3.8.2 Clock Management

The CGU generates all clock signals required within the microcontroller from a single clock, f_{sys} . During normal system operation, the typical frequencies of the different modules are as follow:

- CPU clock: CCLK, SCLK = 24 MHz
- MultiCAN clock : MCANCLK = 24 or 48 MHz
- MDU clock : MDUCLK = 24 or 48 MHz
- CORDIC clock : CORDICCLK = 24 or 48 MHz
- CCU6 clock : CCU6CLK = 24 or 48 MHz
- T2CCU clock : T2CCUCLK = 24 or 48 MHz
- Peripheral clock: PCLK = 24 MHz

In addition, different clock frequencies can be output to pin CLKOUT (P0.0 or P0.7). The clock output frequency, which is derived from the clock output divider (bit COREL), can further be divided by 2 using toggle latch (bit TLEN is set to 1). The resulting output frequency has a 50% duty cycle. [Figure 22](#) shows the clock distribution of the XC87x.

Functional Description



Figure 22 Clock Generation from f_{sys}

Functional Description

For power saving purposes, the clocks may be disabled or slowed down according to [Table 27](#).

Table 27 System frequency ($f_{\text{sys}} = 144 \text{ MHz}$)

Power Saving Mode	Action
Idle	Clock to the CPU is disabled.
Slow-down	Clocks to the CPU and all the peripherals are divided by a common programmable factor defined by bit field CMCON.CLKREL.
Power-down ¹⁾	Oscillator and PLL are switched off.

1) SAK product variant does not support power-down mode.

3.9 Power Saving Modes

The power saving modes of the XC87x provide flexible power consumption through a combination of techniques, including:

- Stopping the CPU clock
- Stopping the clocks of individual system components
- Reducing clock speed of some peripheral components
- Power-down of the entire system with fast restart capability

After a reset, the active mode (normal operating mode) is selected by default (see [Figure 23](#)) and the system runs in the main system clock frequency. From active mode, different power saving modes can be selected by software. They are:

- Idle mode
- Slow-down mode
- Power-down mode



Figure 23 Transition between Power Saving Modes

Note: SAK product variant does not support power-down mode.

3.10 Watchdog Timer

The Watchdog Timer (WDT) provides a highly reliable and secure way to detect and recover from software or hardware failures. The WDT is reset at a regular interval that is predefined by the user. The CPU must service the WDT within this interval to prevent the WDT from causing an XC87x system reset. Hence, routine service of the WDT confirms that the system is functioning properly. This ensures that an accidental malfunction of the XC87x will be aborted in a user-specified time period.

In debug mode, the WDT is default suspended and stops counting. Therefore, there is no need to refresh the WDT during debugging.

Features

- 16-bit Watchdog Timer
- Programmable reload value for upper 8 bits of timer
- Programmable window boundary
- Selectable input frequency of $f_{PCLK}/2$ or $f_{PCLK}/128$
- Time-out detection with NMI generation and reset prewarning activation (after which a system reset will be performed)

The WDT is a 16-bit timer incremented by a count rate of $f_{PCLK}/2$ or $f_{PCLK}/128$. This 16-bit timer is realized as two concatenated 8-bit timers. The upper 8 bits of the WDT can be preset to a user-programmable value via a watchdog service access in order to modify the watchdog expire time period. The lower 8 bits are reset on each service access.

Figure 24 shows the block diagram of the WDT unit.

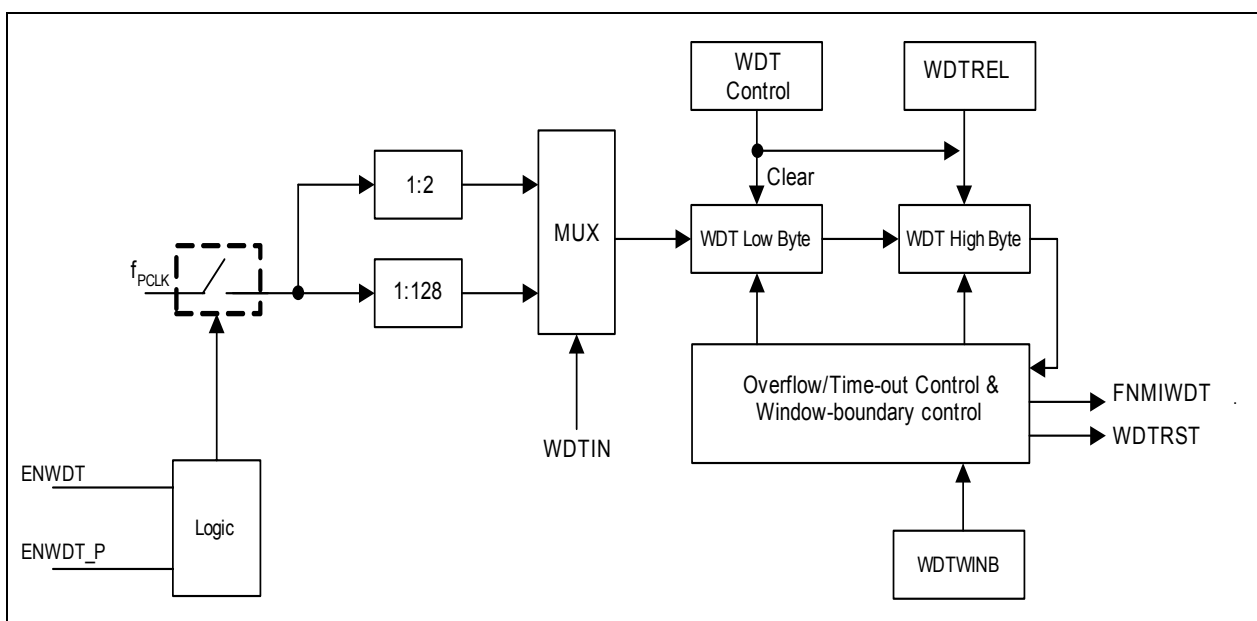

Figure 24 WDT Block Diagram

Functional Description

If the WDT is not serviced before the timer overflow, a system malfunction is assumed. As a result, the WDT NMI is triggered (assert FNMIWDT) and the reset prewarning is entered. The prewarning period lasts for 30_H count, after which the system is reset (assert WDTRST).

The WDT has a “programmable window boundary” which disallows any refresh during the WDT’s count-up. A refresh during this window boundary constitutes an invalid access to the WDT, causing the reset prewarning to be entered but without triggering the WDT NMI. The system will still be reset after the prewarning period is over. The window boundary is from 0000_H to the value obtained from the concatenation of WDTWINB and 00_H.

After being serviced, the WDT continues counting up from the value (<WDTREL> * 2⁸). The time period for an overflow of the WDT is programmable in two ways:

- The input frequency to the WDT can be selected to be either $f_{PCLK}/2$ or $f_{PCLK}/128$
- The reload value WDTREL for the high byte of WDT can be programmed in register WDTREL

The period, P_{WDT} , between servicing the WDT and the next overflow can be determined by the following formula:

$$P_{WDT} = \frac{2^{(1 + WDTIN \times 6)} \times (2^{16} - WDTREL \times 2^8)}{f_{PCLK}} \quad (3.3)$$

If the Window-Boundary Refresh feature of the WDT is enabled, the period P_{WDT} between servicing the WDT and the next overflow is shortened if WDTWINB is greater than WDTREL, see [Figure 25](#). This period can be calculated using the same formula by replacing WDTREL with WDTWINB. For this feature to be useful, WDTWINB cannot be smaller than WDTREL.



Figure 25 WDT Timing Diagram

Table 28 lists the possible watchdog time ranges that can be achieved using a certain module clock. Some numbers are rounded to 3 significant digits.

Table 28 Watchdog Time Ranges

Reload value In WDTREL	Prescaler for f_{PCLK}	
	2 (WDTIN = 0)	128 (WDTIN = 1)
	24 MHz	24 MHz
FF _H	21.3 μ s	1.37 ms
7F _H	2.75 ms	176 ms
00 _H	5.46 ms	350 ms

3.11 Multiplication/Division Unit

The Multiplication/Division Unit (MDU) provides fast 16-bit multiplication, 16-bit and 32-bit division as well as shift and normalize features. It has been integrated to support the XC87x Core in real-time control applications, which require fast mathematical computations.

Features

- Fast signed/unsigned 16-bit multiplication
- Fast signed/unsigned 32-bit divide by 16-bit and 16-bit divide by 16-bit operations
- 32-bit unsigned normalize operation
- 32-bit arithmetic/logical shift operations

Table 29 specifies the number of clock cycles used for calculation in various operations.

Table 29 MDU Operation Characteristics

Operation	Result	Remainder	No. of Clock Cycles used for calculation
Signed 32-bit/16-bit	32-bit	16-bit	33
Signed 16-bit/16bit	16-bit	16-bit	17
Signed 16-bit x 16-bit	32-bit	-	16
Unsigned 32-bit/16-bit	32-bit	16-bit	32
Unsigned 16-bit/16-bit	16-bit	16-bit	16
Unsigned 16-bit x 16-bit	32-bit	-	16
32-bit normalize	-	-	No. of shifts + 1 (Max. 32)
32-bit shift L/R	-	-	No. of shifts + 1 (Max. 32)

3.12 CORDIC Coprocessor

The CORDIC Coprocessor provides CPU with hardware support for the solving of circular (trigonometric), linear (multiply-add, divide-add) and hyperbolic functions.

Features

- Modes of operation
 - Supports all CORDIC operating modes for solving circular (trigonometric), linear (multiply-add, divide-add) and hyperbolic functions
 - Integrated look-up tables (LUTs) for all operating modes
- Circular vectoring mode: Extended support for values of initial X and Y data up to full range of $[-2^{15}, (2^{15}-1)]$ for solving angle and magnitude
- Circular rotation mode: Extended support for values of initial Z data up to full range of $[-2^{15}, (2^{15}-1)]$, representing angles in the range $[-\pi, ((2^{15}-1)/2^{15})\pi]$ for solving trigonometry
- Implementation-dependent operational frequency of up to 80 MHz
- Gated clock input to support disabling of module
- 16-bit accessible data width
 - 24-bit kernel data width plus 2 overflow bits for X and Y each
 - 20-bit kernel data width plus 1 overflow bit for Z
 - With KEEP bit to retain the last value in the kernel register for a new calculation
- 16 iterations per calculation: Approximately 41 clock-cycles or less, from set of start (ST) bit to set of end-of-calculation flag, excluding time taken for write and read access of data bytes.
- Twos complement data processing
 - Only exception: X result data with user selectable option for unsigned result
- X and Y data generally accepted as integer or rational number; X and Y must be of the same data form
- Entries of LUTs are 20-bit signed integers
 - Entries of atan and atanh LUTs are integer representations (S19) of angles with the scaling such that $[-2^{15}, (2^{15}-1)]$ represents the range $[-\pi, ((2^{15}-1)/2^{15})\pi]$
 - Accessible Z result data for circular and hyperbolic functions is integer in data form of S15
- Emulated LUT for linear function
 - Data form is 1 integer bit and 15-bit fractional part (1.15)
 - Accessible Z result data for linear function is rational number with fixed data form of S4.11 (signed 4Q16)
- Truncation Error
 - The result of a CORDIC calculation may return an approximation due to truncation of LSBs
 - Good accuracy of the CORDIC calculated result data, especially in circular mode
- Interrupt
 - On completion of a calculation

- Interrupt enabling and corresponding flag

3.13 UART and UART1

The XC87x provides two Universal Asynchronous Receiver/Transmitter (UART and UART1) modules for full-duplex asynchronous reception/transmission. Both are also receive-buffered, i.e., they can commence reception of a second byte before a previously received byte has been read from the receive register. However, if the first byte still has not been read by the time reception of the second byte is complete, one of the bytes will be lost.

Features

- Full-duplex asynchronous modes
 - 8-bit or 9-bit data frames, LSB first
 - Fixed or variable baud rate
- Receive buffered
- Multiprocessor communication
- Interrupt generation on the completion of a data transmission or reception

The UART modules can operate in the four modes shown in [Table 30](#).

Table 30 **UART Modes**

Operating Mode	Baud Rate
Mode 0: 8-bit shift register	$f_{PCLK}/2$
Mode 1: 8-bit shift UART	Variable
Mode 2: 9-bit shift UART	$f_{PCLK}/32$ or $f_{PCLK}/64$ ¹⁾
Mode 3: 9-bit shift UART	Variable

1) For UART1 module, the baud rate is fixed at $f_{PCLK}/64$.

There are several ways to generate the baud rate clock for the serial port, depending on the mode in which it is operating. In mode 0, the baud rate for the transfer is fixed at $f_{PCLK}/2$. In mode 2, the baud rate is generated internally based on the UART input clock and can be configured to either $f_{PCLK}/32$ or $f_{PCLK}/64$. For UART1 module, only $f_{PCLK}/64$ is available. The variable baud rate is set by the underflow rate on the dedicated baud-rate generator. For UART module, the variable baud rate alternatively can be set by the overflow rate on Timer 1.

3.13.1 Baud-Rate Generator

Both UART modules have their own dedicated baud-rate generator, which is based on a programmable 8-bit reload value, and includes divider stages (i.e., prescaler and

Functional Description

fractional divider) for generating a wide range of baud rates based on its input clock f_{PCLK} , see [Figure 26](#).



Figure 26 Baud-rate Generator Circuitry

The baud rate timer is a count-down timer and is clocked by either the output of the fractional divider (f_{MOD}) if the fractional divider is enabled ($FDCON.FDEN = 1$), or the output of the prescaler (f_{DIV}) if the fractional divider is disabled ($FDEN = 0$). For baud rate generation, the fractional divider must be configured to fractional divider mode ($FDCON.FDM = 0$). This allows the baud rate control run bit $BCON.R$ to be used to start or stop the baud rate timer. At each timer underflow, the timer is reloaded with the 8-bit reload value in register BG and one clock pulse is generated for the serial channel.

Enabling the fractional divider in normal divider mode ($FDEN = 1$ and $FDM = 1$) stops the baud rate timer and nullifies the effect of bit $BCON.R$. See [Section 3.14](#).

The baud rate (f_{BR}) value is dependent on the following parameters:

- Input clock f_{PCLK}
- Prescaling factor (2^{BRPRE}) defined by bit field BRPRE in register BCON
- Fractional divider (STEP/256) defined by register FDSTEP (to be considered only if fractional divider is enabled and operating in fractional divider mode)
- 8-bit reload value (BR_VALUE) for the baud rate timer defined by register BG

Functional Description

The following formulas calculate the final baud rate without and with the fractional divider respectively:

$$\text{baud rate} = \frac{f_{\text{PCLK}}}{16 \times 2^{\text{BRPRE}} \times (\text{BR_VALUE} + 1)} \quad \text{where } 2^{\text{BRPRE}} \times (\text{BR_VALUE} + 1) > 1 \quad (3.4)$$

$$\text{baud rate} = \frac{f_{\text{PCLK}}}{16 \times 2^{\text{BRPRE}} \times (\text{BR_VALUE} + 1)} \times \frac{\text{STEP}}{256} \quad (3.5)$$

The maximum baud rate that can be generated is limited to $f_{\text{PCLK}}/32$. Hence, for a module clock of 24 MHz, the maximum achievable baud rate is 0.75 MBaud.

Standard LIN protocol can support a maximum baud rate of 20 kHz, the baud rate accuracy is not critical and the fractional divider can be disabled. Only the prescaler is used for auto baud rate calculation. For LIN fast mode, which supports the baud rate of 20 kHz to 57.6 kHz, the higher baud rates require the use of the fractional divider for greater accuracy.

Table 31 lists the various commonly used baud rates with their corresponding parameter settings and deviation errors. The fractional divider is disabled and a module clock of 24 MHz is used.

Table 31 Typical Baud rates for UART with Fractional Divider disabled

Baud rate	Prescaling Factor (2BRPRE)	Reload Value (BR_VALUE + 1)	Deviation Error
19.2 kBaud	1 (BRPRE=000 _B)	78 (4E _H)	0.17 %
9600 Baud	1 (BRPRE=000 _B)	156 (9C _H)	0.17 %
4800 Baud	2 (BRPRE=001 _B)	156 (9C _H)	0.17 %
2400 Baud	4 (BRPRE=010 _B)	156 (9C _H)	0.17 %

The fractional divider allows baud rates of higher accuracy (lower deviation error) to be generated. **Table 32** lists the resulting deviation errors from generating a baud rate of 57.6 kHz, using different module clock frequencies. The fractional divider is enabled (fractional divider mode) and the corresponding parameter settings are shown.

Table 32 Deviation Error for UART with Fractional Divider enabled

f_{PCLK}	Prescaling Factor (2BRPRE)	Reload Value (BR_VALUE + 1)	STEP	Deviation Error
24 MHz	1	6 (6 _H)	59 (3B _H)	+0.03 %
12 MHz	1	3 (3 _H)	59 (3B _H)	+0.03 %
8 MHz	1	2 (2 _H)	59 (3B _H)	+0.03 %
6 MHz	1	6 (6 _H)	236 (EC _H)	+0.03 %

3.13.2 Baud Rate Generation using Timer 1

In UART modes 1 and 3 of UART module, Timer 1 can be used for generating the variable baud rates. In theory, this timer could be used in any of its modes. But in practice, it should be set into auto-reload mode (Timer 1 mode 2), with its high byte set to the appropriate value for the required baud rate. The baud rate is determined by the Timer 1 overflow rate and the value of SMOD as follows:

$$\text{Mode 1, 3 baud rate} = \frac{2^{\text{SMOD}} \times f_{PCLK}}{32 \times 2 \times (256 - \text{TH1})} \quad (3.6)$$

3.14 Normal Divider Mode (8-bit Auto-reload Timer)

Setting bit FDM in register FDCON to 1 configures the fractional divider to normal divider mode, while at the same time disables baud rate generation (see [Figure 26](#)). Once the fractional divider is enabled (FDEN = 1), it functions as an 8-bit auto-reload timer (with no relation to baud rate generation) and counts up from the reload value with each input clock pulse. Bit field RESULT in register FDRES represents the timer value, while bit field STEP in register FDSTEP defines the reload value. At each timer overflow, an overflow flag (FDCON.NDOV) will be set and an interrupt request generated. This gives an output clock f_{MOD} that is 1/n of the input clock f_{DIV} , where n is defined by 256 - STEP. The output frequency in normal divider mode is derived as follows:

$$f_{MOD} = f_{DIV} \times \frac{1}{256 - \text{STEP}} \quad (3.7)$$

3.15 LIN Protocol

The UART module can be used to support the Local Interconnect Network (LIN) protocol for both master and slave operations. The LIN baud rate detection feature, which consists of the hardware logic for Break and Synch Byte detection, provides the capability to detect the baud rate within LIN protocol using Timer 2. This allows the UART to be synchronized to the LIN baud rate for data transmission and reception.

Note: The LIN baud rate detection feature is available for use only with UART. To use UART1 for LIN communication, software has to be implemented to detect the Break and Synch Byte.

LIN is a holistic communication concept for local interconnected networks in vehicles. The communication is based on the SCI (UART) data format, a single-master/multiple-slave concept, a clock synchronization for nodes without stabilized time base. An attractive feature of LIN is self-synchronization of the slave nodes without a crystal or ceramic resonator, which significantly reduces the cost of hardware platform. Hence, the baud rate must be calculated and returned with every message frame.

The structure of a LIN frame is shown in **Figure 27**. The frame consists of the:

- Header, which comprises a Break (13-bit time low), Synch Byte (55_H), and ID field
- Response time
- Data bytes (according to UART protocol)
- Checksum



Figure 27 Structure of LIN Frame

3.15.1 LIN Header Transmission

LIN header transmission is only applicable in master mode. In the LIN communication, a master task decides when and which frame is to be transferred on the bus. It also identifies a slave task to provide the data transported by each frame. The information

Functional Description

needed for the handshaking between the master and slave tasks is provided by the master task through the header portion of the frame.

The header consists of a break and synch pattern followed by an identifier. Among these three fields, only the break pattern cannot be transmitted as a normal 8-bit UART data. The break must contain a dominant value of 13 bits or more to ensure proper synchronization of slave nodes.

In the LIN communication, a slave task is required to be synchronized at the beginning of the protected identifier field of frame. For this purpose, every frame starts with a sequence consisting of a break field followed by a synch byte field. This sequence is unique and provides enough information for any slave task to detect the beginning of a new frame and be synchronized at the start of the identifier field.

Upon entering LIN communication, a connection is established and the transfer speed (baud rate) of the serial communication partner (host) is automatically synchronized in the following steps:

STEP 1: Initialize interface for reception and timer for baud rate measurement

STEP 2: Wait for an incoming LIN frame from host

STEP 3: Synchronize the baud rate to the host

STEP 4: Enter for Master Request Frame or for Slave Response Frame

Note: Re-synchronization and setup of baud rate are always done for every Master Request Header or Slave Response Header LIN frame.

3.16 High-Speed Synchronous Serial Interface

The High-Speed Synchronous Serial Interface (SSC) supports full-duplex and half-duplex synchronous communication. The serial clock signal can be generated by the SSC internally (master mode), using its own 16-bit baud-rate generator, or can be received from an external master (slave mode). Data width, shift direction, clock polarity and phase are programmable. This allows communication with SPI-compatible devices or devices using other synchronous serial interfaces.

Features

- Master and slave mode operation
 - Full-duplex or half-duplex operation
- Transmit and receive buffered
- Flexible data format
 - Programmable number of data bits: 2 to 8 bits
 - Programmable shift direction: LSB or MSB shift first
 - Programmable clock polarity: idle low or high state for the shift clock
 - Programmable clock/data phase: data shift with leading or trailing edge of the shift clock
- Variable baud rate
- Compatible with Serial Peripheral Interface (SPI)
- Interrupt generation
 - On a transmitter empty condition
 - On a receiver full condition
 - On an error condition (receive, phase, baud rate, transmit error)

Data is transmitted or received on lines TXD and RXD, which are normally connected to the pins MTSR (Master Transmit/Slave Receive) and MRST (Master Receive/Slave Transmit). The clock signal is output via line MS_CLK (Master Serial Shift Clock) or input via line SS_CLK (Slave Serial Shift Clock). Both lines are normally connected to the pin SCLK. Transmission and reception of data are double-buffered.

Figure 28 shows the block diagram of the SSC.

Functional Description

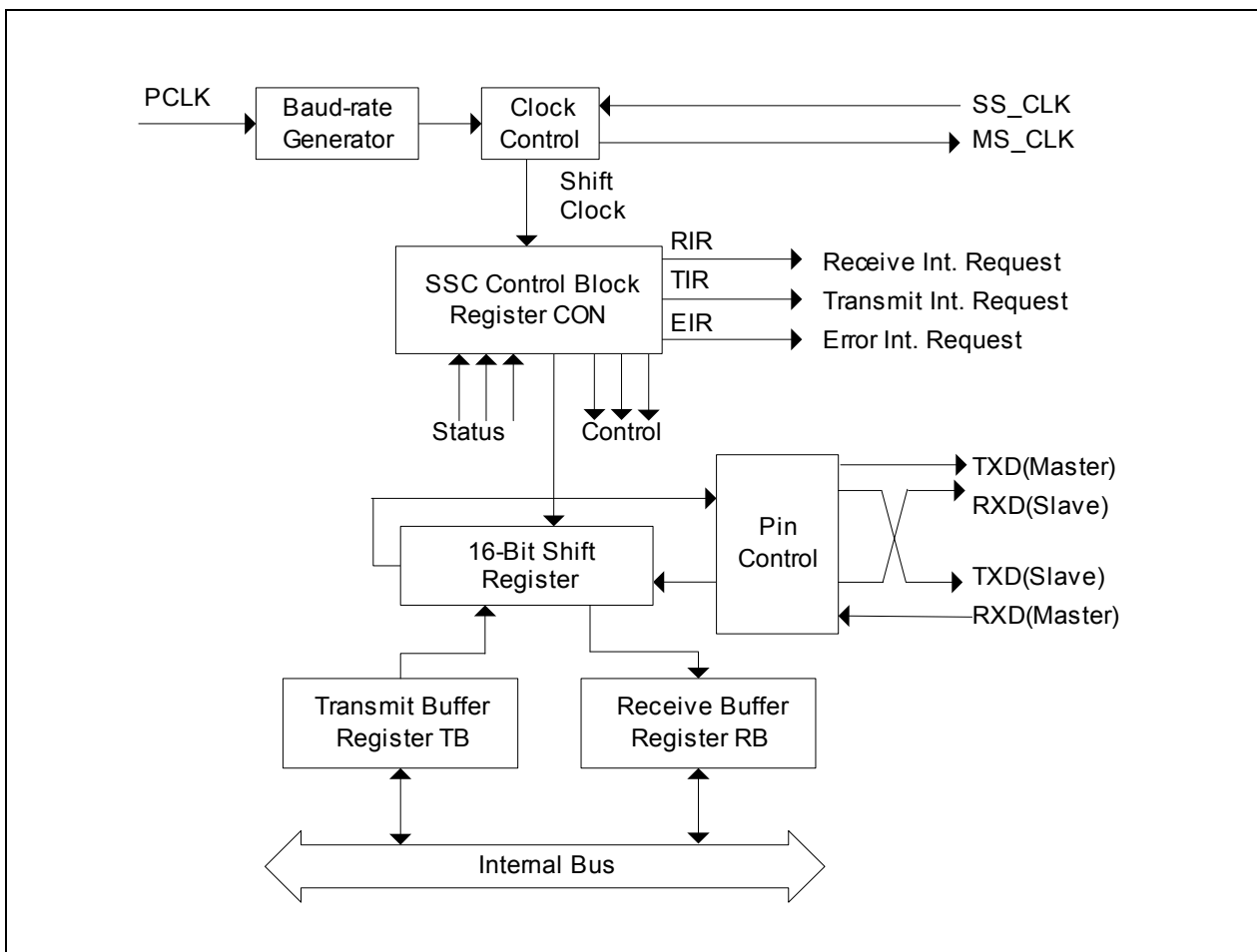

Figure 28 SSC Block Diagram

3.17 Timer 0 and Timer 1

Timer 0 and Timer 1 can function as both timers or counters. When functioning as a timer, Timer 0 and Timer 1 are incremented every machine cycle, i.e. every 2 input clocks (or 2 PCLKs). When functioning as a counter, Timer 0 and Timer 1 are incremented in response to a 1-to-0 transition (falling edge) at their respective external input pins, T0 or T1.

Timer 0 and 1 are fully compatible and can be configured in four different operating modes for use in a variety of applications, see [Table 33](#). In modes 0, 1 and 2, the two timers operate independently, but in mode 3, their functions are specialized.

Table 33 Timer 0 and Timer 1 Modes

Mode	Operation
0	13-bit timer The timer is essentially an 8-bit counter with a divide-by-32 prescaler. This mode is included solely for compatibility with Intel 8048 devices.
1	16-bit timer The timer registers, TLx and THx, are concatenated to form a 16-bit counter.
2	8-bit timer with auto-reload The timer register TLx is reloaded with a user-defined 8-bit value in THx upon overflow.
3	Timer 0 operates as two 8-bit timers The timer registers, TL0 and TH0, operate as two separate 8-bit counters. Timer 1 is halted and retains its count even if enabled.

3.18 Timer 2 and Timer 21

Timer 2 and Timer 21 are 16-bit general purpose timers (THL2) that are fully compatible and have two modes of operation, a 16-bit auto-reload mode and a 16-bit one channel capture mode, see [Table 34](#). As a timer, the timers count with an input clock of PCLK/12 (if prescaler is disabled). As a counter, they count 1-to-0 transitions on pin T2. In the counter mode, the maximum resolution for the count is PCLK/24 (if prescaler is disabled).

Table 34 Timer 2 Modes

Mode	Description
Auto-reload	Up/Down Count Disabled <ul style="list-style-type: none"> • Count up only • Start counting from 16-bit reload value, overflow at FFFF_H • Reload event configurable for trigger by overflow condition only, or by negative/positive edge at input pin T2EX as well • Programmable reload value in register RC2 • Interrupt is generated with reload event
	Up/Down Count Enabled <ul style="list-style-type: none"> • Count up or down, direction determined by level at input pin T2EX • No interrupt is generated • Count up <ul style="list-style-type: none"> – Start counting from 16-bit reload value, overflow at FFFF_H – Reload event triggered by overflow condition – Programmable reload value in register RC2 • Count down <ul style="list-style-type: none"> – Start counting from FFFF_H, underflow at value defined in register RC2 – Reload event triggered by underflow condition – Reload value fixed at FFFF_H
Channel capture	<ul style="list-style-type: none"> • Count up only • Start counting from 0000_H, overflow at FFFF_H • Reload event triggered by overflow condition • Reload value fixed at 0000_H • Capture event triggered by falling/rising edge at pin T2EX • Captured timer value stored in register RC2 • Interrupt is generated with reload or capture event

3.19 Timer 2 Capture/Compare Unit

The T2CCU (Timer 2 Capture/Compare Unit) consists of the standard Timer 2 unit and a Capture/compare unit (CCU). The Capture/Compare Timer (CCT) is part of the CCU. Control is available in the T2CCU to select individually for each of its 16-bit capture/compare channel, either the Timer 2 or the Capture/Compare Timer (CCT) as the time base. Both timers have a resolution of 16 bits. The clock frequency of T2CCU, f_{T2CCU} , could be set at PCLK frequency or 2 times the PCLK frequency.

The T2CCU can be used for various digital signal generation and event capturing like pulse generation, pulse width modulation, pulse width measuring etc. Target applications include various automotive control as well as industrial (frequency generation, digital-to-analog conversion, process control etc.).

T2CCU Features

- Option to select individually for each channel, either Timer 2 or Capture/Compare Timer as time base
- Extremely flexible Capture/Compare Timer count rate by cascading with Timer 2
- Capture/Compare Timer may be 'reset' immediately by triggering overflow event
- 16-bit resolution
- Six compare channels in total
- Four capture channels multiplexed with the compare channels, in total
- Shadow register for each compare register
 - Transfer via software control or on timer overflow.
- Compare Mode 0: Compare output signal changes from the inactive level to active level on compare match. Returns to inactive level on timer overflow.
 - Active level can be defined by register bit for channel groups A and B.
 - Support of 0% to 100% duty cycle in compare mode 0.
- Compare Mode 1: Full control of the software on the compare output signal level, for the next compare match.
- Concurrent Compare Mode with channel 0
- Capture Mode 0: Capture on any external event (rising/falling/both edge) at the 4 pins T2CC0 to T2CC3.
- Capture Mode 1: Capture upon writing to the low byte of the corresponding channel capture register.
- Capture mode 0 or 1 can be established independently on the 4 capture channels.

3.20 Capture/Compare Unit 6

The Capture/Compare Unit 6 (CCU6) provides two independent timers (T12, T13), which can be used for Pulse Width Modulation (PWM) generation, especially for AC-motor control. The CCU6 also supports special control modes for block commutation and multi-phase machines.

The timer T12 can function in capture and/or compare mode for its three channels. The timer T13 can work in compare mode only.

The multi-channel control unit generates output patterns, which can be modulated by T12 and/or T13. The modulation sources can be selected and combined for the signal modulation.

Timer T12 Features

- Three capture/compare channels, each channel can be used either as a capture or as a compare channel
- Supports generation of a three-phase PWM (six outputs, individual signals for highside and lowside switches)
- 16-bit resolution, maximum count frequency = peripheral clock frequency
- Dead-time control for each channel to avoid short-circuits in the power stage
- Concurrent update of the required T12/13 registers
- Generation of center-aligned and edge-aligned PWM
- Supports single-shot mode
- Supports many interrupt request sources
- Hysteresis-like control mode

Timer T13 Features

- One independent compare channel with one output
- 16-bit resolution, maximum count frequency = peripheral clock frequency
- Can be synchronized to T12
- Interrupt generation at period-match and compare-match
- Supports single-shot mode

Additional Features

- Implements block commutation for Brushless DC-drives
- Position detection via Hall-sensor pattern
- Automatic rotational speed measurement for block commutation
- Integrated error handling
- Fast emergency stop without CPU load via external signal ($\overline{\text{CTRAP}}$)
- Control modes for multi-channel AC-drives
- Output levels can be selected and adapted to the power stage

The block diagram of the CCU6 module is shown in [Figure 29](#).

Functional Description



Figure 29 CCU6 Block Diagram

Functional Description

3.21 Controller Area Network (MultiCAN)

The MultiCAN module contains two Full-CAN nodes operating independently or exchanging data and remote frames via a gateway function. Transmission and reception of CAN frames is handled in accordance to CAN specification V2.0 B active. Each CAN node can receive and transmit standard frames with 11-bit identifiers as well as extended frames with 29-bit identifiers.

Both CAN nodes share a common set of message objects, where each message object may be individually allocated to one of the CAN nodes. Besides serving as a storage container for incoming and outgoing frames, message objects may be combined to build gateways between the CAN nodes or to setup a FIFO buffer.

The message objects are organized in double chained lists, where each CAN node has it's own list of message objects. A CAN node stores frames only into message objects that are allocated to the list of the CAN node. It only transmits messages from objects of this list. A powerful, command driven list controller performs all list operations.

The bit timings for the CAN nodes are derived from the peripheral clock (f_{CAN}) and are programmable up to a data rate of 1 Mbaud. A pair of receive and transmit pins connects each CAN node to a bus transceiver.



Figure 30 Overview of the MultiCAN

Features

- Compliant to ISO 11898.

Functional Description

- CAN functionality according to CAN specification V2.0 B active.
- Dedicated control registers are provided for each CAN node.
- A data transfer rate up to 1 MBaud is supported.
- Flexible and powerful message transfer control and error handling capabilities are implemented.
- Advanced CAN bus bit timing analysis and baud rate detection can be performed for each CAN node via the frame counter.
- Full-CAN functionality: A set of 32 message objects can be individually
 - allocated (assigned) to any CAN node
 - configured as transmit or receive object
 - setup to handle frames with 11-bit or 29-bit identifier
 - counted or assigned a timestamp via a frame counter
 - configured to remote monitoring mode
- Advanced Acceptance Filtering:
 - Each message object provides an individual acceptance mask to filter incoming frames.
 - A message object can be configured to accept only standard or only extended frames or to accept both standard and extended frames.
 - Message objects can be grouped into 4 priority classes.
 - The selection of the message to be transmitted first can be performed on the basis of frame identifier, IDE bit and RTR bit according to CAN arbitration rules.
- Advanced Message Object Functionality:
 - Message Objects can be combined to build FIFO message buffers of arbitrary size, which is only limited by the total number of message objects.
 - Message objects can be linked to form a gateway to automatically transfer frames between 2 different CAN buses. A single gateway can link any two CAN nodes. An arbitrary number of gateways may be defined.
- Advanced Data Management:
 - The Message objects are organized in double chained lists.
 - List reorganizations may be performed any time, even during full operation of the CAN nodes.
 - A powerful, command driven list controller manages the organization of the list structure and ensures consistency of the list.
 - Message FIFOs are based on the list structure and can easily be scaled in size during CAN operation.
 - Static Allocation Commands offer compatibility with TwinCAN applications, which are not list based.
- Advanced Interrupt Handling:
 - Up to 8 interrupt output lines are available. Most interrupt requests can be individually routed to one of the 8 interrupt output lines.
 - Message postprocessing notifications can be flexibly aggregated into a dedicated register field of 64 notification bits.

3.22 Analog-to-Digital Converter

The XC87x includes a high-performance 10-bit Analog-to-Digital Converter (ADC) with eight multiplexed analog input channels. The ADC uses a successive approximation technique to convert the analog voltage levels from up to eight different sources. The analog input channels of the ADC are available at AN0 - AN7.

Features

- Successive approximation
- 8-bit or 10-bit resolution
- Eight analog channels
- Four independent result registers
- Result data protection for slow CPU access (wait-for-read mode)
- Single conversion mode
- Autoscan functionality
- Limit checking for conversion results
- Data reduction filter (accumulation of up to 2 conversion results)
- Two independent conversion request sources with programmable priority
- Selectable conversion request trigger
- Flexible interrupt generation with configurable service nodes
- Programmable sample time
- Programmable clock divider
- Cancel/restart feature for running conversions
- Integrated sample and hold circuitry
- Compensation of offset errors
- Low power modes

3.22.1 ADC Clocking Scheme

A common module clock f_{ADC} generates the various clock signals used by the analog and digital parts of the ADC module:

- f_{ADCA} is input clock for the analog part.
- f_{ADCI} is internal clock for the analog part (defines the time base for conversion length and the sample time). This clock is generated internally in the analog part, based on the input clock f_{ADCA} to generate a correct duty cycle for the analog components.
- f_{ADCD} is input clock for the digital part.

Figure 31 shows the clocking scheme of the ADC module. The prescaler ratio is selected by bit field CTC in register GLOBCTR. A prescaling ratio of 32 can be selected when the maximum performance of the ADC is not required.

Functional Description



Figure 31 ADC Clocking Scheme

For module clock $f_{ADC} = 24$ MHz, the analog clock f_{ADCl} frequency can be selected as shown in [Table 35](#).

Table 35 f_{ADCl} Frequency Selection

Module Clock f_{ADC}	CTC	Prescaling Ratio	Analog Clock f_{ADCl}
24 MHz	00 _B	÷ 2	12 MHz
	01 _B	÷ 3	8 MHz
	10 _B	÷ 4	6 MHz
	11 _B (default)	÷ 32	750 kHz

During slow-down mode, f_{ADC} may be reduced further, for example, to 12 MHz or 6 MHz. However, it is important to note that the conversion error could increase due to loss of charges on the capacitors, if f_{ADC} becomes too low during slow-down mode.

3.22.2 ADC Conversion Sequence

The analog-to-digital conversion procedure consists of the following phases:

Functional Description

- Synchronization phase (t_{SYN})
- Sample phase (t_S)
- Conversion phase
- Write result phase (t_{WR})



Figure 32 ADC Conversion Timing

3.23 On-Chip Debug Support

The On-Chip Debug Support (OCDS) provides the basic functionality required for the software development and debugging of XC800-based systems.

The OCDS design is based on these principles:

- Use the built-in debug functionality of the XC800 Core
- Add a minimum of hardware overhead
- Provide support for most of the operations by a Monitor Program
- Use standard interfaces to communicate with the Host (a Debugger)

Features

- Set breakpoints on instruction address and on address range within the Program Memory
- Set breakpoints on internal RAM address range
- Support unlimited software breakpoints in Flash/RAM code region
- Process external breaks via JTAG and upon activating a dedicated pin
- Step through the program code

The OCDS functional blocks are shown in [Figure 33](#). The Monitor Mode Control (MMC) block at the center of OCDS system brings together control signals and supports the overall functionality. The MMC communicates with the XC800 Core, primarily via the Debug Interface, and also receives reset and clock signals.

After processing memory address and control signals from the core, the MMC provides proper access to the dedicated extra-memories: a Monitor ROM (holding the code) and a Monitor RAM (for work-data and Monitor-stack).

The OCDS system is accessed through the JTAG¹⁾, which is an interface dedicated exclusively for testing and debugging activities and is not normally used in an application. The dedicated MBC pin is used for external configuration and debugging control.

Note: All the debug functionality described here can normally be used only after XC87x has been started in OCDS mode.

1) The pins of the JTAG port can be assigned to either the primary port (Port 0) or either of the secondary ports (Ports 1 and 2/Port 5).

User must set the JTAG pins (TCK and TDI) as input during connection with the OCDS system.

Functional Description

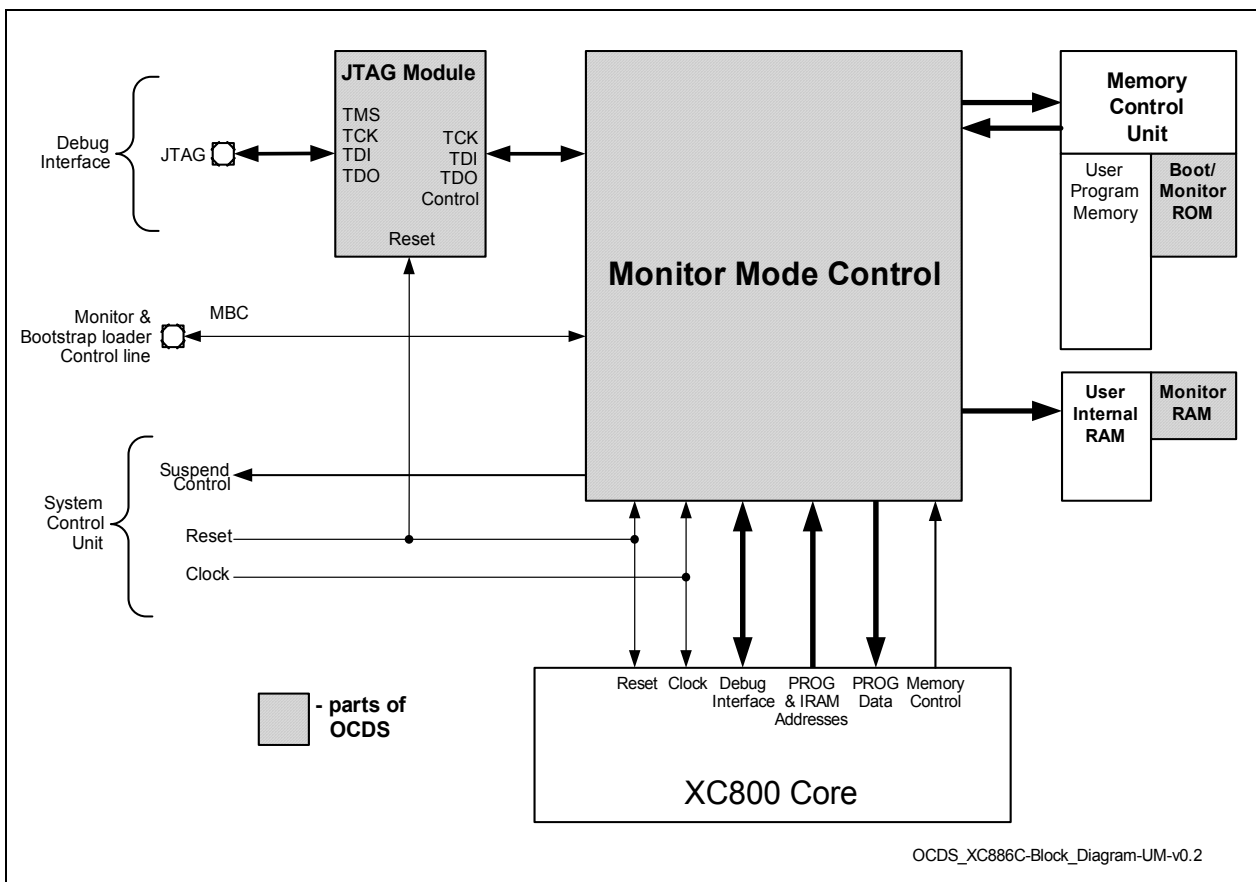

Figure 33 OCDS Block Diagram

3.2.3.1 JTAG ID Register

This is a read-only register located inside the JTAG module, and is used to recognize the device(s) connected to the JTAG interface. Its content is shifted out when INSTRUCTION register contains the IDCODE command (opcode 04_H), and the same is also true immediately after reset.

The JTAG ID register contents for the XC87x Flash devices are given in [Table 36](#).

Table 36 JTAG ID Summary

Device Type	Device Name	JTAG ID
Flash	XC87x*-16FF	1018 2083 _H
	XC87x*-13FF	1018 3083 _H

Note: The asterisk () above denotes all possible device configurations.*

3.24 Chip Identification Number

The XC87x identity (ID) register is located at Page 1 of address B3_H. The value of ID register is 49_H. However, for easy identification of product variants, the Chip Identification Number, which is a unique number assigned to each product variant, is available. The differentiation is based on the product, variant type and device step information.

Two methods are provided to read a device's chip identification number:

- In-application subroutine, GET_CHIP_INFO
- Bootstrap loader (BSL) mode A

Table 37 lists the chip identification numbers of available XC87x Flash device variants.

Table 37 Chip Identification Number

Product Variant	Chip Identification Number
	AC-step
Flash Devices	
XC878-16FF 5V	4B580063 _H
XC878M-16FF 5V	4B580023 _H
XC878CM-16FF 5V	4B580003 _H
XC878LM-16FF 5V	4B500023 _H
XC878CLM-16FF 5V	4B500003 _H
XC878-13FF 5V	4B590463 _H
XC878M-13FF 5V	4B590423 _H
XC878CM-13FF 5V	4B590403 _H
XC878LM-13FF 5V	4B510423 _H
XC878CLM-13FF 5V	4B510403 _H
XC878-16FF 3V3	4B180063 _H
XC878M-16FF 3V3	4B180023 _H
XC878CM-16FF 3V3	4B180003 _H
XC878-13FF 3V3	4B190463 _H
XC878M-13FF 3V3	4B190423 _H
XC878CM-13FF 3V3	4B190403 _H
XC874CM-16FV 5V	4B580002 _H
XC874LM-16FV 5V	4B500022 _H
XC874-16FV 5V	4B580062 _H

Table 37 Chip Identification Number (cont'd)

Product Variant	Chip Identification Number
	AC-step
XC874CM-13FV 5V	4B590402 _H
XC874LM-13FV 5V	4B510422 _H
XC874-13FV 5V	4B590462 _H

4 Electrical Parameters

Chapter 4 provides the characteristics of the electrical parameters which are implementation-specific for the XC87x.

4.1 General Parameters

The general parameters are described here to aid the users in interpreting the parameters mainly in [Section 4.2](#) and [Section 4.3](#).

4.1.1 Parameter Interpretation

The parameters listed in this section represent partly the characteristics of the XC87x and partly its requirements on the system. To aid interpreting the parameters easily when evaluating them for a design, they are indicated by the abbreviations in the "Symbol" column:

- **CC**
These parameters indicate **C**ontroller **C**haracteristics, which are distinctive features of the XC87x and must be regarded for a system design.
- **SR**
These parameters indicate **S**ystem **R**equirements, which must be provided by the microcontroller system in which the XC87x is designed in.

4.1.2 Absolute Maximum Rating

Maximum ratings are the extreme limits to which the XC87x can be subjected to without permanent damage.

Table 38 Absolute Maximum Rating Parameters

Parameter	Symbol	Limit Values		Unit	Notes
		min.	max.		
Ambient temperature	T_A	-40	125	°C	under bias
Storage temperature	T_{ST}	-65	150	°C	
Junction temperature	T_J	-40	140	°C	under bias
Voltage on power supply pin with respect to V_{SS}	V_{DDP}	-0.5	6	V	
Voltage on any pin with respect to V_{SS}	V_{IN}	-0.5	$V_{DDP} + 0.5$ or max. 6	V	Whatever is lower
Input current on any pin during overload condition	I_{IN}	-10	10	mA	
Absolute sum of all input currents during overload condition	$\Sigma I_{IN} $	–	50	mA	

Note: Stresses above those listed under “Absolute Maximum Ratings” may cause permanent damage to the device. This is a stress rating only and functional operation of the device at these or any other conditions above those indicated in the operational sections of this specification is not implied. Exposure to absolute maximum rating conditions for extended periods may affect device reliability. During absolute maximum rating overload conditions ($V_{IN} > V_{DDP}$ or $V_{IN} < V_{SS}$) the voltage on V_{DDP} pin with respect to ground (V_{SS}) must not exceed the values defined by the absolute maximum ratings.

4.1.3 Operating Conditions

The following operating conditions must not be exceeded in order to ensure correct operation of the XC87x. All parameters mentioned in the following table refer to these operating conditions, unless otherwise noted.

Table 39 Operating Condition Parameters

Parameter	Symbol	Limit Values		Unit	Notes/ Conditions
		min.	max.		
Digital power supply voltage	V_{DDP}	4.5	5.5	V	5V Device
Digital power supply voltage	V_{DDP}	3.0	3.6	V	3.3V Device
Digital ground voltage	V_{SS}	0		V	
CPU Clock Frequency ¹⁾	f_{CCLK}		26.67 ²⁾	MHz	
Ambient temperature	T_A	-40	85	°C	SAF-XC878/874...
		-40	105	°C	SAX-XC878...
		-40	125	°C	SAK-XC878/874...

1) f_{CCLK} is the input frequency to the XC800 core. Please refer to [Figure 22](#) for detailed description.

2) Default setting of f_{CCLK} upon reset is 24 MHz.

4.2 DC Parameters

The electrical characteristics of the DC Parameters are detailed in this section.

4.2.1 Input/Output Characteristics

Table 40 provides the characteristics of the input/output pins of the XC87x.

Table 40 Input/Output Characteristics (Operating Conditions apply)

Parameter	Symbol		Limit Values		Unit	Test Conditions
			min.	max.		
$V_{DDP} = 5\text{ V Range}$						
Output low voltage	V_{OL}	CC	–	0.6	V	$I_{OL} = 9\text{ mA (DS = 0)}^{1)}$ $I_{OL} = 12\text{ mA (DS = 1)}^{2)}$
Output high voltage	V_{OH}	CC	2.4	–	V	$I_{OH} = -20\text{ mA (DS = 0)}^{1)}$ $I_{OH} = -25\text{ mA (DS = 1)}^{2)}$
Input low voltage	V_{IL}	SR	-0.3	0.8	V	CMOS Mode
Input high voltage	V_{IH}	SR	2.2	V_{DDP}	V	CMOS Mode
Input Hysteresis	HYS	CC	0.35	–	V	CMOS Mode ³⁾⁷⁾
Input low voltage at XTAL1	V_{ILX}	SR	-0.3	0.8	V	
Input high voltage at XTAL1	V_{IHX}	SR	3.4	V_{DDP}	V	
Pull-up current	I_{PU}	SR	–	-20	μA	$V_{IH,min}$
			-88	–	μA	$V_{IL,max}$
Pull-down current	I_{PD}	SR	–	10	μA	$V_{IL,max}$
			66	–	μA	$V_{IH,min}$
Input leakage current	I_{OZ1}	CC	-1	1	μA	$0 < V_{IN} < V_{DDP}$, $T_A \leq 105^\circ\text{C}^{4)}$
Overload current on any pin	I_{OV}	SR	-5	5	mA	
Absolute sum of overload currents	$\Sigma I_{OV} $	SR	–	25	mA	⁵⁾
Voltage on any pin during V_{DDP} power off	V_{PO}	SR	–	0.3	V	⁶⁾

Electrical Parameters
Table 40 Input/Output Characteristics (Operating Conditions apply) (cont'd)

Parameter	Symbol		Limit Values		Unit	Test Conditions
			min.	max.		
Maximum current per pin (excluding V_{DDP} and V_{SS})	I_M	SR SR	–	25	mA	
Maximum current for all pins (excluding V_{DDP} and V_{SS})	$\Sigma I_M $	SR	–	150	mA	
Maximum current into V_{DDP}	I_{MVDDP}	SR	–	200	mA	⁵⁾
Maximum current out of V_{SS}	I_{MVSS}	SR	–	200	mA	⁵⁾
$V_{DDP} = 3.3$ V Range						
Output low voltage	V_{OL}	CC	–	0.5	V	$I_{OL} = 6$ mA (DS = 0) ¹⁾ $I_{OL} = 8$ mA (DS = 1) ²⁾
Output high voltage	V_{OH}	CC	2.2	–	V	$I_{OH} = -5$ mA (DS = 0) ¹⁾ $I_{OH} = -7$ mA (DS = 1) ²⁾
Input low voltage	V_{IL}	SR	-0.3	0.7	V	CMOS Mode
Input high voltage	V_{IH}	SR	2	V_{DDP}	V	CMOS Mode
Input Hysteresis	<i>HYS</i>	CC	0.28	–	V	CMOS Mode ³⁾⁷⁾
Input low voltage at XTAL1	V_{ILX}	SR	-0.3	0.7	V	
Input high voltage at XTAL1	V_{IHx}	SR	2.3	V_{DDP}	V	
Pull-up current	I_{PU}	SR	–	-7	μ A	$V_{IH,min}$
			-35	–	μ A	$V_{IL,max}$
Pull-down current	I_{PD}	SR	–	12	μ A	$V_{IL,max}$
			60	–	μ A	$V_{IH,min}$
Input leakage current	I_{OZ1}	CC	-1	1	μ A	$0 < V_{IN} < V_{DDP}$, $T_A \leq 105^\circ\text{C}^4)$
Overload current on any pin	I_{OV}	SR	-5	5	mA	
Absolute sum of overload currents	$\Sigma I_{OV} $	SR	–	25	mA	⁵⁾

Electrical Parameters
Table 40 Input/Output Characteristics (Operating Conditions apply) (cont'd)

Parameter	Symbol	SR	Limit Values		Unit	Test Conditions
			min.	max.		
Voltage on any pin during V_{DDP} power off	V_{PO}	SR	–	0.3	V	6)
Maximum current per pin (excluding V_{DDP} and V_{SS})	I_M	SR SR	–	8	mA	
Maximum current for all pins (excluding V_{DDP} and V_{SS})	$\Sigma I_M $	SR	–	150	mA	
Maximum current into V_{DDP}	I_{MVDDP}	SR	–	200	mA	5)
Maximum current out of V_{SS}	I_{MVSS}	SR	–	200	mA	5)

- 1) DS = 0 refers to the pin having a weak drive strength which is programmable via Px_DS register.
- 2) DS = 1 refers to the pin having a strong drive strength which is programmable via Px_DS register.
- 3) Not subjected to production test, verified by design/characterization. Hysteresis is implemented to avoid meta stable states and switching due to internal ground bounce. It cannot be guaranteed that it suppresses switching due to external system noise.
- 4) An additional error current (I_{INJ}) will flow if an overload current flows through an adjacent pin. TMS pin and $\overline{\text{RESET}}$ pin have internal pull devices and are not included in the input leakage current characteristic.
- 5) Not subjected to production test, verified by design/characterization.
- 6) Not subjected to production test, verified by design/characterization. However, for applications with strict low power-down current requirements, it is mandatory that no active voltage source is supplied at any GPIO pin when V_{DDP} is powered off.
- 7) P0.1 has a minimum input hysteresis of 0.25V.

4.2.2 Supply Threshold Characteristics

Table 41 provides the characteristics of the supply threshold in the XC87x.

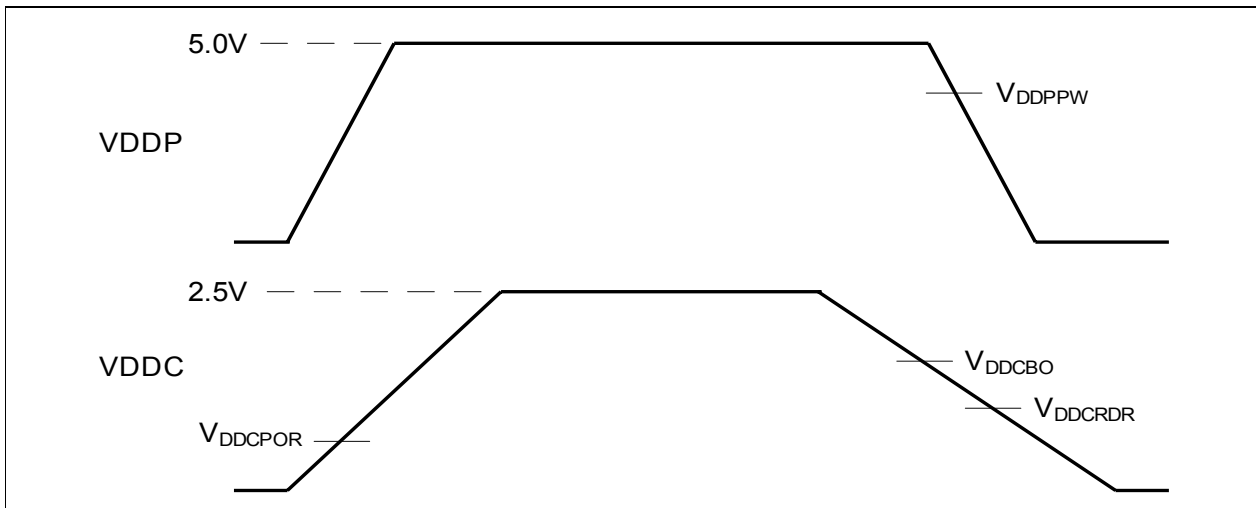

Figure 34 Supply Threshold Parameters

Table 41 Supply Threshold Parameters (Operating Conditions apply)

Parameters	Symbol		Limit Values			Unit
			min.	typ.	max.	
V_{DDC} brownout voltage ¹⁾	V_{DDCBO}	CC	1.7	1.9	2.2	V
RAM data retention voltage	V_{DDCRDR}	CC	1.2	–	–	V
V_{DDP} prewarning voltage ²⁾	V_{DDPPW}	CC	3.8	4.2	4.5	V
Power-on reset voltage ¹⁾³⁾	V_{DDCPOR}	CC	1.7	1.9	2.2	V

1) Detection is enabled in both active and power-down mode.

2) Detection is enabled for 5.0V power supply variant.
Detection is disabled for 3.3V power supply variant.

3) The reset of EVR is extended by 300 μ s typically after the VDDC reaches the power-on reset voltage.

Electrical Parameters
4.2.3 ADC Characteristics

The values in the table below are given for an analog power supply between 4.5 V to 5.5 V. The ADC can be used with an analog power supply down to 3 V. But in this case, the analog parameters may show a reduced performance. All ground pins (V_{SS}) must be externally connected to one single star point in the system. The voltage difference between the ground pins must not exceed 200mV.

Table 42 ADC Characteristics (Operating Conditions apply; $V_{DDP} = 5V$ Range)

Parameter	Symbol		Limit Values			Unit	Test Conditions/ Remarks
			min.	typ .	max.		
Analog reference voltage	V_{AREF}	SR	$V_{AGND} + 1$	V_{DDP}	$V_{DDP} + 0.05$	V	¹⁾
Analog reference ground	V_{AGND}	SR	$V_{SS} - 0.05$	V_{SS}	$V_{AREF} - 1$	V	¹⁾
Analog input voltage range	V_{AIN}	SR	V_{AGND}	–	V_{AREF}	V	
ADC clocks	f_{ADC}		–	24	–	MHz	module clock ¹⁾
	f_{ADCI}		–	–	14 ²⁾	MHz	internal analog clock ¹⁾ See Figure 31
Sample time	t_S	CC	$(2 + INPCR0.STC) \times t_{ADCI}$			μs	¹⁾
Conversion time	t_C	CC	See Section 4.2.3.1			μs	¹⁾
Differential Nonlinearity	$ EA_{DNL} $	CC	–	–	1.5	LSB	10-bit conversion
Integral Nonlinearity	$ EA_{INL} $	CC	–	–	2	LSB	10-bit conversion
Offset	$ EA_{OFF} $	CC	–	–	3	LSB	10-bit conversion
Gain	$ EA_{GAIN} $	CC	–	–	2.5	LSB	10-bit conversion
Switched capacitance at the reference voltage input	C_{AREFSW}	CC	–	10	14	pF	¹⁾³⁾
Switched capacitance at the analog voltage inputs	C_{AINSW}	CC	–	4	5	pF	¹⁾⁴⁾

Electrical Parameters

Table 42 ADC Characteristics (Operating Conditions apply; $V_{DDP} = 5V$ Range)

Parameter	Symbol		Limit Values			Unit	Test Conditions/ Remarks
			min.	typ .	max.		
Input resistance of the reference input	R_{AREF}	CC	–	1	2	k Ω	1)
Input resistance of the selected analog channel	R_{AIN}	CC	–	1	3	k Ω	1)

- 1) Not subjected to production test, verified by design/characterization.
- 2) This value includes the maximum oscillator deviation.
- 3) This represents an equivalent switched capacitance. This capacitance is not switched to the reference voltage at once. Instead of this, smaller capacitances are successively switched to the reference voltage.
- 4) The sampling capacity of the conversion C-Network is pre-charged to $V_{AREF}/2$ before connecting the input to the C-Network. Because of the parasitic elements, the voltage measured at ANx is lower than $V_{AREF}/2$.

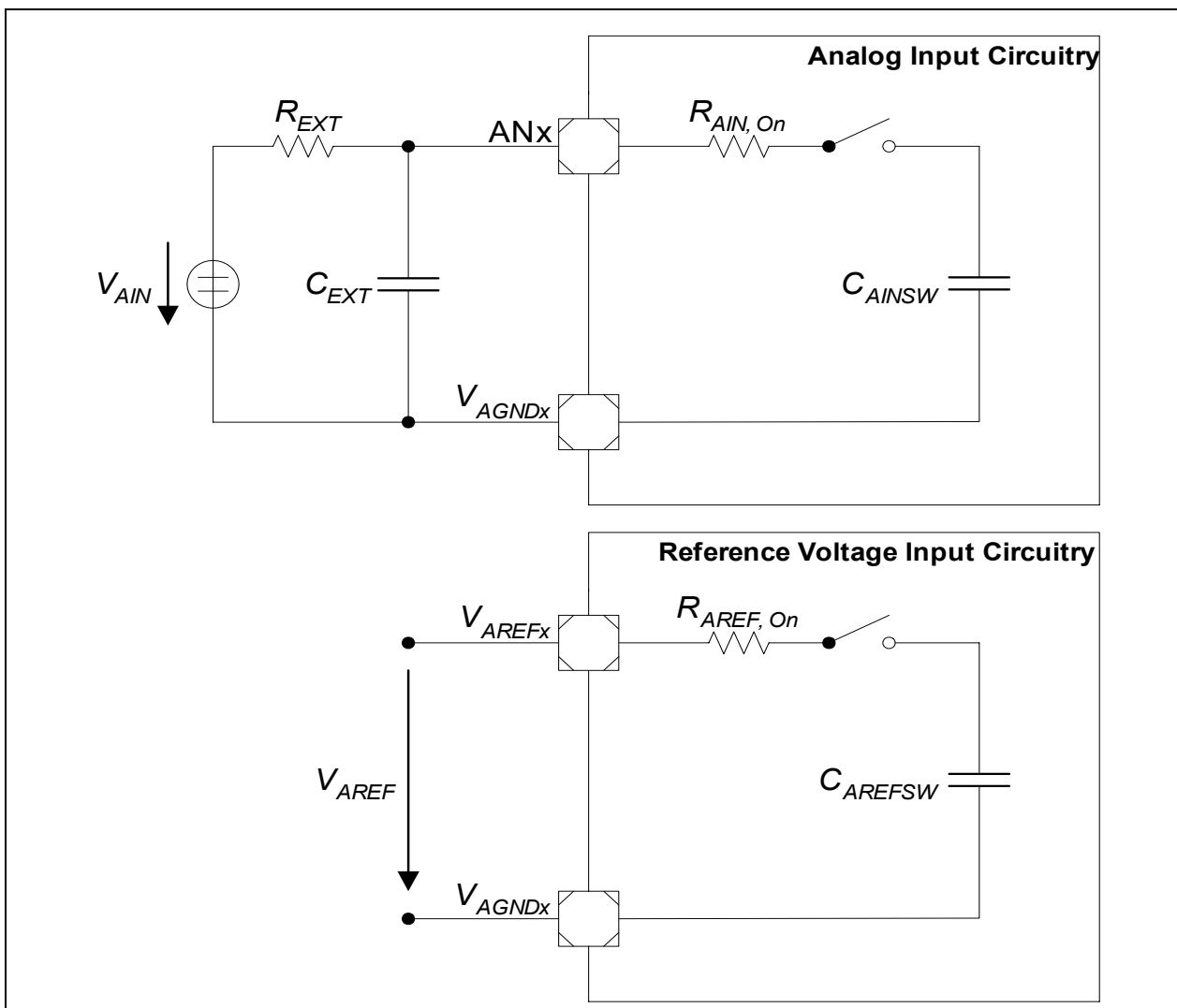

Figure 35 ADC Input Circuits

4.2.3.1 ADC Conversion Timing

Conversion time, $t_C = t_{ADC} \times (1 + r \times (3 + n + STC))$, where

$r = CTC + 2$ for $CTC = 00_B, 01_B$ or 10_B ,

$r = 32$ for $CTC = 11_B$,

$CTC =$ Conversion Time Control (GLOBCTR.CTC),

$STC =$ Sample Time Control (INPCR0.STC),

$n = 8$ or 10 (for 8-bit and 10-bit conversion respectively),

$t_{ADC} = 1 / f_{ADC}$

4.2.4 Power Supply Current

Table 43, **Table 44**, **Table 45** and **Table 46** provide the characteristics of the power supply current in the XC87x.

**Table 43 Power Supply Current Parameters (Operating Conditions apply;
 $V_{DDP} = 5V$ range)**

Parameter	Symbol	Limit Values		Unit	Test Conditions
		typ. ¹⁾	max. ²⁾		
$V_{DDP} = 5V$ Range					
Active Mode	I_{DDP}	37.5	45	mA	³⁾ SAF and SAX variants
		40.5	48	mA	³⁾ SAK variant
Idle Mode	I_{DDP}	29.2	35	mA	⁴⁾ SAF and SAX variants
		32.2	38	mA	⁴⁾ SAK variant
Active Mode with slow-down enabled	I_{DDP}	10	15	mA	⁵⁾ SAF and SAX variants
		13	18	mA	⁵⁾ SAK variant
Idle Mode with slow-down enabled	I_{DDP}	9.2	14	mA	⁶⁾ SAF and SAX variants
		12.2	17	mA	⁶⁾ SAK variant

1) The typical I_{DDP} values are based on preliminary measurements and are to be used as reference only. These values are periodically measured at $T_A = +25\text{ °C}$ and $V_{DDP} = 5.0\text{ V}$.

2) The maximum I_{DDP} values are measured under worst case conditions ($T_A = +105\text{ °C}$ and $V_{DDP} = 5.5\text{ V}$).

3) I_{DDP} (active mode) is measured with: CPU clock and input clock to all peripherals running at 24 MHz with on-chip oscillator of 4 MHz, $\overline{\text{RESET}} = V_{DDP}$; all other pins are disconnected, no load on ports.

4) I_{DDP} (idle mode) is measured with: CPU clock disabled, watchdog timer disabled, input clock to all peripherals enabled and running at 24 MHz, $\overline{\text{RESET}} = V_{DDP}$; all other pins are disconnected, no load on ports.

5) I_{DDP} (active mode with slow-down mode) is measured with: CPU clock and input clock to all peripherals running at 1 MHz by setting CLKREL in CMCON to 1000_B, $\overline{\text{RESET}} = V_{DDP}$; all other pins are disconnected, no load on ports.

6) I_{DDP} (idle mode with slow-down mode) is measured with: CPU clock disabled, watchdog timer disabled, input clock to all peripherals enabled and running at 1 MHz by setting CLKREL in CMCON to 1000_B, $\overline{\text{RESET}} = V_{DDP}$; all other pins are disconnected, no load on ports.

Electrical Parameters
Table 44 Power Down Current¹⁾(Operating Conditions apply; $V_{DDP} = 5V$ range)

Parameter	Symbol	Limit Values		Unit	Test Conditions
		typ. ²⁾	max. ³⁾		
$V_{DDP} = 5V$ Range					
Power-Down Mode	I_{PDP}	20	80	μA	$T_A = + 25\text{ }^{\circ}C^{4)5)}$
		-	250	μA	$T_A = + 85\text{ }^{\circ}C^{5)6)}$

- 1) The table is only applicable to SAF and SAX variants. SAK variant does not support power-down mode
- 2) The typical I_{PDP} values are based on preliminary measurements and are to be used as reference only. These values are measured at $V_{DDP} = 5.0\text{ V}$.
- 3) The maximum I_{PDP} values are measured at $V_{DDP} = 5.5\text{ V}$.
- 4) I_{PDP} has a maximum value of $450\text{ }\mu A$ at $T_A = + 105\text{ }^{\circ}C$.
- 5) I_{PDP} is measured with: $\overline{RESET} = V_{DDP}$, $V_{AGND} = V_{SS}$, $RXD/INT0 = V_{DDP}$; rest of the ports are programmed to be input with either internal pull devices enabled or driven externally to ensure no floating inputs.
- 6) Not subjected to production test, verified by design/characterization.

Electrical Parameters
**Table 45 Power Supply Current Parameters¹⁾ (Operating Conditions apply;
 $V_{DDP} = 3.3V$ range)**

Parameter	Symbol	Limit Values		Unit	Test Conditions
		typ. ²⁾	max. ³⁾		
$V_{DDP} = 3.3V$ Range					
Active Mode	I_{DDP}	35.4	43	mA	4)
Idle Mode	I_{DDP}	27.6	33	mA	5)
Active Mode with slow-down enabled	I_{DDP}	8.6	13	mA	6)
Idle Mode with slow-down enabled	I_{DDP}	8	12	mA	7)

1) The table is only applicable to SAF and SAX variants.

2) The typical I_{DDP} values are based on preliminary measurements and are to be used as reference only. These values are periodically measured at $T_A = +25^\circ\text{C}$ and $V_{DDP} = 3.3\text{V}$.

3) The maximum I_{DDP} values are measured under worst case conditions ($T_A = +105^\circ\text{C}$ and $V_{DDP} = 3.6\text{V}$).

4) I_{DDP} (active mode) is measured with: CPU clock and input clock to all peripherals running at 24 MHz with on-chip oscillator of 4 MHz, $\overline{\text{RESET}} = V_{DDP}$; all other pins are disconnected, no load on ports.

5) I_{DDP} (idle mode) is measured with: CPU clock disabled, watchdog timer disabled, input clock to all peripherals enabled and running at 24 MHz, $\overline{\text{RESET}} = V_{DDP}$; all other pins are disconnected, no load on ports.

6) I_{DDP} (active mode with slow-down mode) is measured with: CPU clock and input clock to all peripherals running at 1 MHz by setting CLKREL in CMCON to 1000_B, $\overline{\text{RESET}} = V_{DDP}$; all other pins are disconnected, no load on ports.

7) I_{DDP} (idle mode with slow-down mode) is measured with: CPU clock disabled, watchdog timer disabled, input clock to all peripherals enabled and running at 1 MHz by setting CLKREL in CMCON to 1000_B, $\overline{\text{RESET}} = V_{DDP}$; all other pins are disconnected, no load on ports.

Electrical Parameters
Table 46 Power Down Current¹⁾(Operating Conditions apply; $V_{DDP} = 3.3V$ range)

Parameter	Symbol	Limit Values		Unit	Test Conditions
		typ. ²⁾	max. ³⁾		
$V_{DDP} = 3.3V$ Range					
Power-Down Mode	I_{PDP}	20	80	μA	$T_A = + 25\text{ }^\circ C^{4)5)}$
		-	250	μA	$T_A = + 85\text{ }^\circ C^{5)6)}$

1) The table is only applicable to SAF and SAX variants.

2) The typical I_{PDP} values are based on preliminary measurements and are to be used as reference only. These values are measured at $V_{DDP} = 3.3 V$.

3) The maximum I_{PDP} values are measured at $V_{DDP} = 3.6 V$.

4) I_{PDP} has a maximum value of $450\text{ }\mu A$ at $T_A = + 105\text{ }^\circ C$.

5) I_{PDP} is measured with: $\overline{RESET} = V_{DDP}$, $V_{AGND} = V_{SS}$, $RXD/INT0 = V_{DDP}$; rest of the ports are programmed to be input with either internal pull devices enabled or driven externally to ensure no floating inputs.

6) Not subjected to production test, verified by design/characterization.

4.3 AC Parameters

The electrical characteristics of the AC Parameters are detailed in this section.

4.3.1 Testing Waveforms

The testing waveforms for rise/fall time, output delay and output high impedance are shown in [Figure 36](#), [Figure 37](#) and [Figure 38](#).



Figure 36 Rise/Fall Time Parameters



Figure 37 Testing Waveform, Output Delay



Figure 38 Testing Waveform, Output High Impedance

4.3.2 Output Rise/Fall Times

Table 47 provides the characteristics of the output rise/fall times in the XC87x.

Table 47 Output Rise/Fall Times Parameters (Operating Conditions apply)

Parameter	Symbol	Limit Values		Unit	Test Conditions
		min.	max.		
$V_{DDP} = 5V$ Range					
Rise/fall times	t_R, t_F	–	10	ns	20 pF. ^{1) 2)3)}
$V_{DDP} = 3.3V$ Range					
Rise/fall times	t_R, t_F	–	10	ns	20 pF. ^{1) 2)4)}

- 1) Rise/Fall time measurements are taken with 10% - 90% of pad supply.
- 2) Not all parameters are 100% tested, but are verified by design/characterization and test correlation.
- 3) Additional rise/fall time valid for $C_L = 20pF - 100pF @ 0.125 ns/pF$.
- 4) Additional rise/fall time valid for $C_L = 20pF - 100pF @ 0.225 ns/pF$.



Figure 39 Rise/Fall Times Parameters

4.3.3 Power-on Reset and PLL Timing

Table 48 provides the characteristics of the power-on reset and PLL timing in the XC87x.

Table 48 Power-On Reset and PLL Timing (Operating Conditions apply)

Parameter	Symbol	CC	Limit Values			Unit	Test Conditions
			min.	typ.	max.		
On-Chip Oscillator start-up time	t_{OSCST}	CC	–	–	500	ns	1)
PLL lock-in in time	t_{LOCK}	CC	–	–	200	μ s	1)
PLL accumulated jitter	D_P		–	–	1.8	ns	1)2)

1) Not all parameters are 100% tested, but are verified by design/characterization and test correlation.

2) PLL lock at 144 MHz using a 4 MHz external oscillator. The PLL Divider settings are K = 2, N = 72 and P = 1.

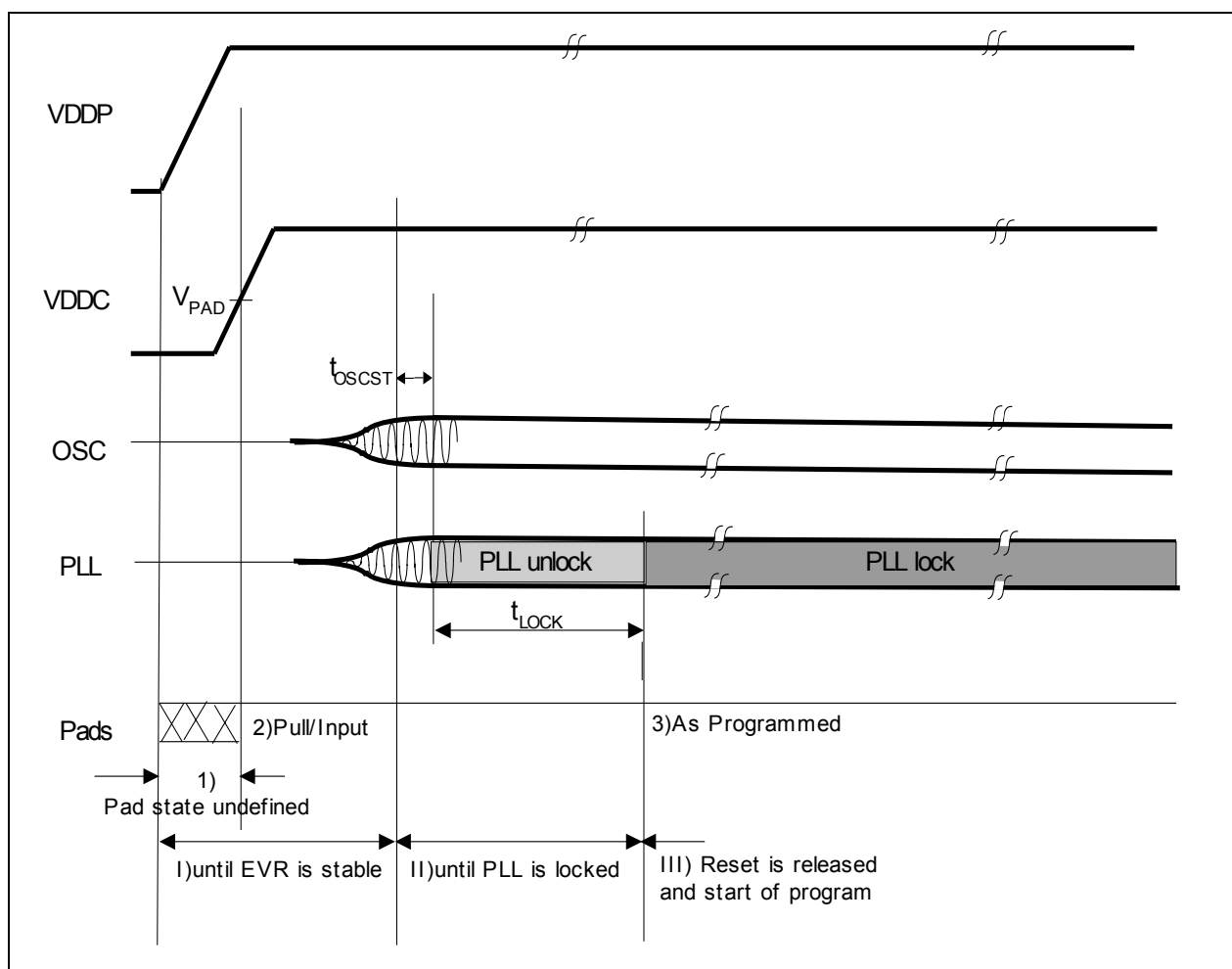

Figure 40 Power-on Reset Timing

4.3.4 On-Chip Oscillator Characteristics

Table 49 provides the characteristics of the on-chip oscillator in the XC87x.

Table 49 On-chip Oscillator Characteristics (Operating Conditions apply)

Parameter	Symbol	Limit Values			Unit	Test Conditions
		min.	typ.	max.		
Nominal frequency	f_{NOM} CC	3.88	4	4.12	MHz	under nominal conditions ¹⁾ after IFX-backend trimming
Long term frequency deviation	Δf_{LT} CC	-5	–	5	%	with respect to f_{NOM} , over lifetime and temperature (-40°C to 105°C), for one given device after trimming
Short term frequency deviation	Δf_{ST} CC	-1.0	–	1.0	%	within one LIN message (<10 ms 100 ms)

1) Nominal condition: $V_{\text{DDC}} = 2.5 \text{ V}$, $T_{\text{A}} = + 25^{\circ}\text{C}$.

4.3.5 External Data Memory Characteristics

Table 50 shows the timing of the external data memory read cycle.

Table 50 External Data Memory Read Timing¹⁾ (Operating Conditions apply)

Parameter	Symbol		Limit Values		Unit	Test Conditions
			Min.	Max.		
\overline{RD} pulse width	t_1	CC	$2 \cdot f_{CCLK} - 17$	-	ns	2)
Address valid to \overline{RD}	t_2	CC	$f_{CCLK} - 12$	-	ns	2)
\overline{RD} to valid data in	t_3	SR	-	$1.5 \cdot f_{CCLK} - 27$	ns	2)
Address to valid data in	t_4	SR	-	$3 \cdot f_{CCLK} - 7$	ns	2)
Data hold after \overline{RD}	t_5	SR	$0.5 \cdot f_{CCLK} - 17$	-	ns	2)

1) External Bus Interface is not available in XC874.

2) Not all parameters are 100% tested, but are verified by design/characterization and test correlation.

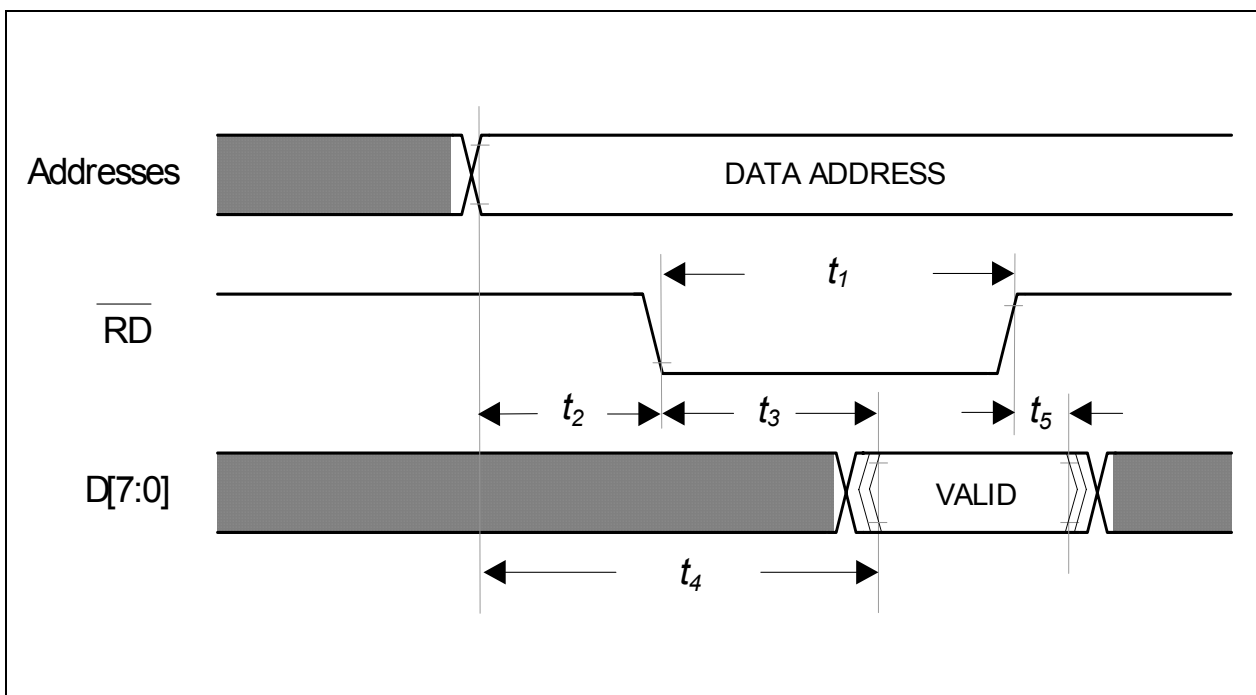

Figure 41 External Data Memory Read Cycle

Electrical Parameters

Table 51 shows the timing of the external data memory write cycle.

Table 51 External Data Memory Write Timing¹⁾ (Operating Conditions apply)

Parameter	Symbol	CC	Limit Values		Unit	Test Conditions
			Min.	Max.		
WR pulse width	t_1	CC	$f_{CCLK} - 10$	-	ns	2)
Address valid to WR	t_2	CC	$2 * f_{CCLK} - 7$	-	ns	2)
Data valid to WR transition	t_3	SR	$f_{CCLK} - 5$	-	ns	2)
Data setup before WR	t_4	SR	$9 * f_{CCLK} - 13$	-	ns	2)
Data hold after WR	t_5	SR	$6 * f_{CCLK} - 3$	-	ns	2)

1) External Bus Interface is not available in XC874.

2) Not all parameters are 100% tested, but are verified by design/characterization and test correlation.

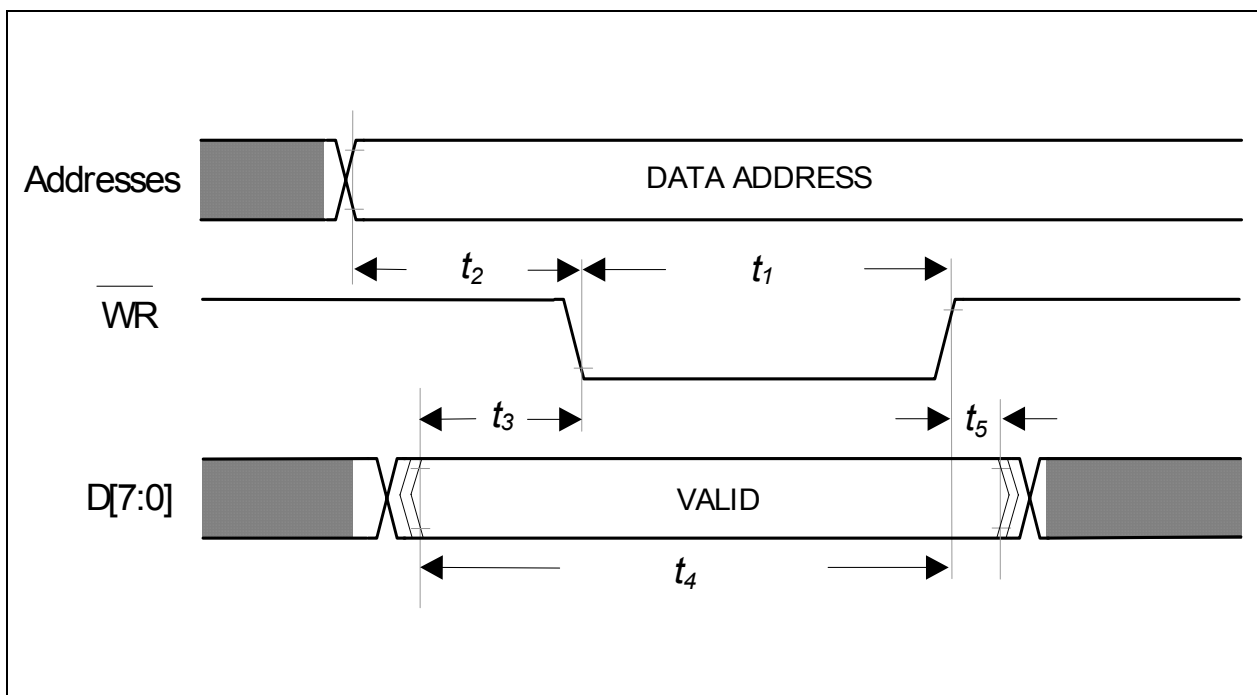

Figure 42 External Data Memory Write Cycle

4.3.6 External Clock Drive XTAL1

Table 52 shows the parameters that define the external clock supply for XC87x. These timing parameters are based on the direct XTAL1 drive of clock input signals. They are not applicable if an external crystal or ceramic resonator is considered.

Table 52 External Clock Drive Characteristics (Operating Conditions apply)

Parameter	Symbol	SR	Limit Values		Unit	Test Conditions
			Min.	Max.		
Oscillator period	t_{osc}	SR	50	500	ns	1)2)
High time	t_1	SR	15	-	ns	2)3)
Low time	t_2	SR	15	-	ns	2)3)
Rise time	t_3	SR	-	10	ns	2)3)
Fall time	t_4	SR	-	10	ns	2)3)

1) The clock input signals with 45-55% duty cycle are used.

2) Not all parameters are 100% tested, but are verified by design/characterization and test correlation.

3) The clock input signal must reach the defined levels V_{ILX} and V_{IHx} .

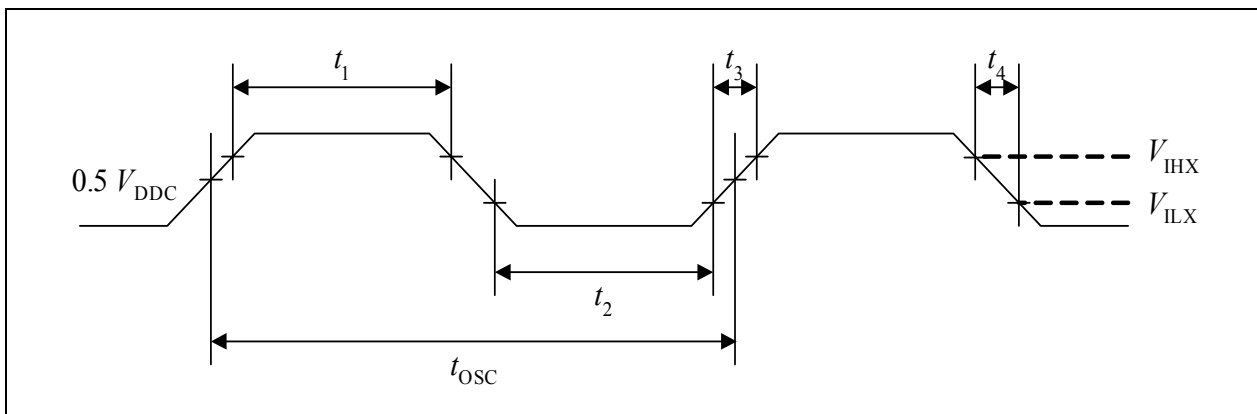

Figure 43 External Clock Drive XTAL1

4.3.7 JTAG Timing

Table 53 provides the characteristics of the JTAG timing in the XC87x.

Table 53 TCK Clock Timing (Operating Conditions apply; CL = 50 pF)

Parameter	Symbol	Limits		Unit	Test Conditions
		min	max		
TCK clock period	t_{TCK} SR	50	-	ns	1)
TCK high time	t_1 SR	20	-	ns	1)
TCK low time	t_2 SR	20	-	ns	1)
TCK clock rise time	t_3 SR	-	4	ns	1)
TCK clock fall time	t_4 SR	-	4	ns	1)

1) Not all parameters are 100% tested, but are verified by design/characterization and test correlation.



Figure 44 TCK Clock Timing

Table 54 JTAG Timing (Operating Conditions apply; CL = 50 pF)

Parameter	Symbol	Limits		Unit	Test Conditions
		min	max		
TMS setup to TCK	t_1 SR	8	-	ns	1)
TMS hold to TCK	t_2 SR	0	-	ns	1)
TDI setup to TCK	t_1 SR	8	-	ns	1)
TDI hold to TCK	t_2 SR	4	-	ns	1)
TDO valid output from TCK	t_3 CC	-	24	ns	5V Device ¹⁾
		-	31	ns	3.3V Device ¹⁾

Electrical Parameters

Table 54 JTAG Timing (Operating Conditions apply; CL = 50 pF) (cont'd)

Parameter	Symbol	Limits		Unit	Test Conditions
		min	max		
TDO high impedance to valid output from TCK	t_4 CC	-	18	ns	5V Device ¹⁾
		-	21	ns	3.3V Device ¹⁾
TDO valid output to high impedance from TCK	t_5 CC	-	21	ns	5V Device ¹⁾
		-	20	ns	3.3V Device ¹⁾

1) Not all parameters are 100% tested, but are verified by design/characterization and test correlation.



Figure 45 JTAG Timing

4.3.8 SSC Master Mode Timing

Table 55 provides the characteristics of the SSC timing in the XC87x.

Table 55 SSC Master Mode Timing (Operating Conditions apply; CL = 50 pF)

Parameter	Symbol		Limit Values		Unit	Test Conditions
			min.	max.		
SCLK clock period	t_0	CC	$2 \cdot T_{SSC}$	–	ns	1)2)
MTSR delay from SCLK	t_1	CC	0	5	ns	2)
MRST setup to SCLK	t_2	SR	13	–	ns	2)
MRST hold from SCLK	t_3	SR	0	–	ns	2)

1) $T_{SSCmin} = T_{CPU} = 1/f_{CPU}$. When $f_{CPU} = 24\text{ MHz}$, $t_0 = 83.3\text{ ns}$. T_{CPU} is the CPU clock period.

2) 1)Not all parameters are 100% tested, but are verified by design/characterization and test correlation.



Figure 46 SSC Master Mode Timing

5 Package and Quality Declaration

Chapter 5 provides the information of the XC87x package and reliability section.

5.1 Package Parameters

Table 56 provides the thermal characteristics of the package used in XC878 and XC874.

Table 56 Thermal Characteristics of the Packages

Parameter	Symbol	Limit Values		Unit	Notes
		Min.	Max.		
PG-LQFP-64-4 (XC878)					
Thermal resistance junction case ¹⁾	R_{TJC} CC	-	13.8	K/W	-
Thermal resistance junction lead ¹⁾	R_{TJL} CC	-	34.6	K/W	-
PG-VQFN-48-22 (XC874)					
Thermal resistance junction case ¹⁾	R_{TJC} CC	-	16.6	K/W	-
Thermal resistance junction lead ¹⁾	R_{TJL} CC	-	30.7	K/W	-

1) The thermal resistances between the case and the ambient (R_{TCA}), the lead and the ambient (R_{TLA}) are to be combined with the thermal resistances between the junction and the case (R_{TJC}), the junction and the lead (R_{TJL}) given above, in order to calculate the total thermal resistance between the junction and the ambient (R_{TJA}). The thermal resistances between the case and the ambient (R_{TCA}), the lead and the ambient (R_{TLA}) depend on the external system (PCB, case) characteristics, and are under user responsibility.

The junction temperature can be calculated using the following equation: $T_J = T_A + R_{TJA} \times P_D$, where the R_{TJA} is the total thermal resistance between the junction and the ambient. This total junction ambient resistance R_{TJA} can be obtained from the upper four partial thermal resistances, by

- simply adding only the two thermal resistances (junction lead and lead ambient), or
- by taking all four resistances into account, depending on the precision needed.

5.2 Package Outline

Figure 47 shows the package outlines of the XC878.

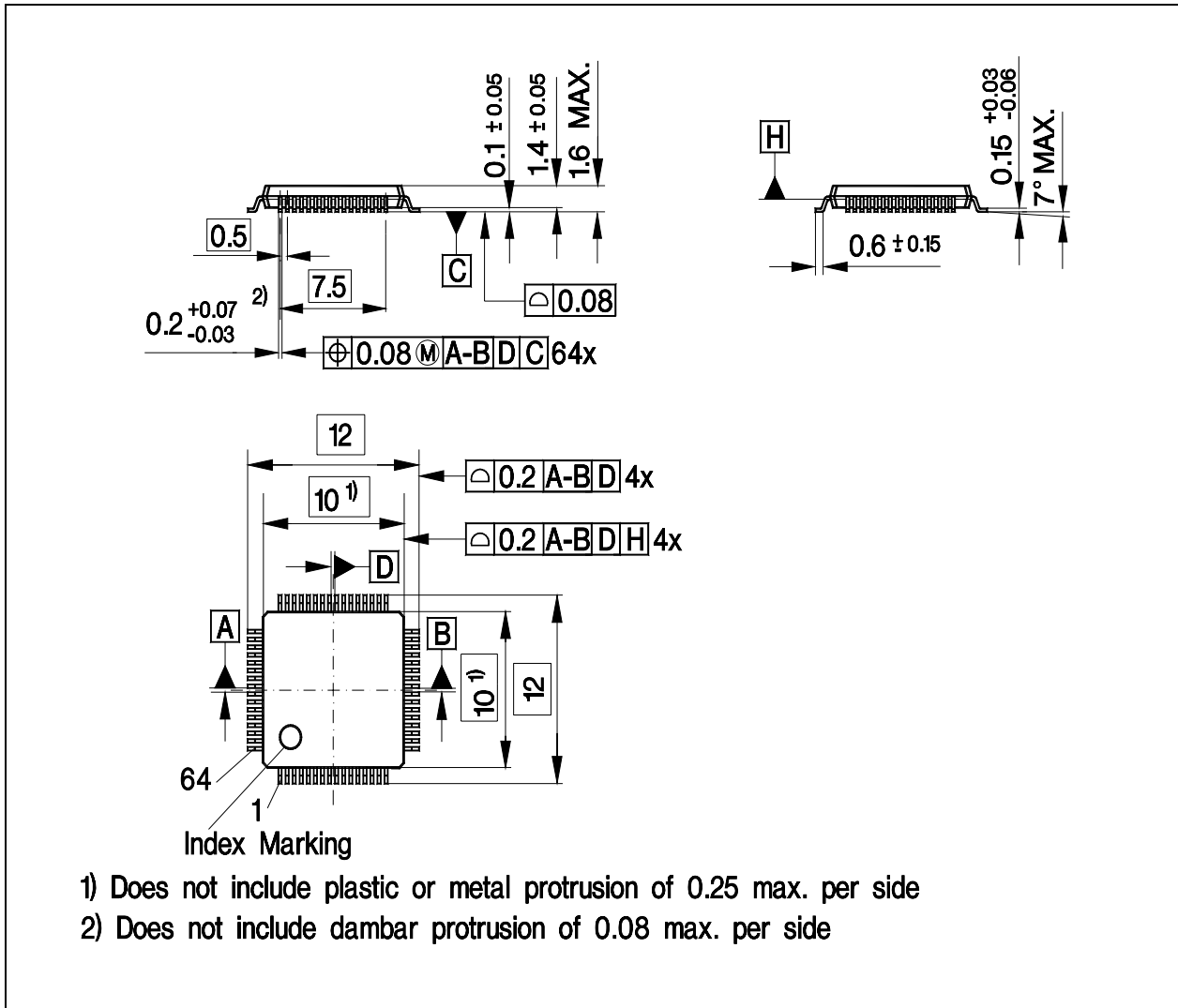

Figure 47 PG-LQFP-64-4 Package Outline

Package and Quality Declaration

Figure 48 shows the package outlines of the XC874.

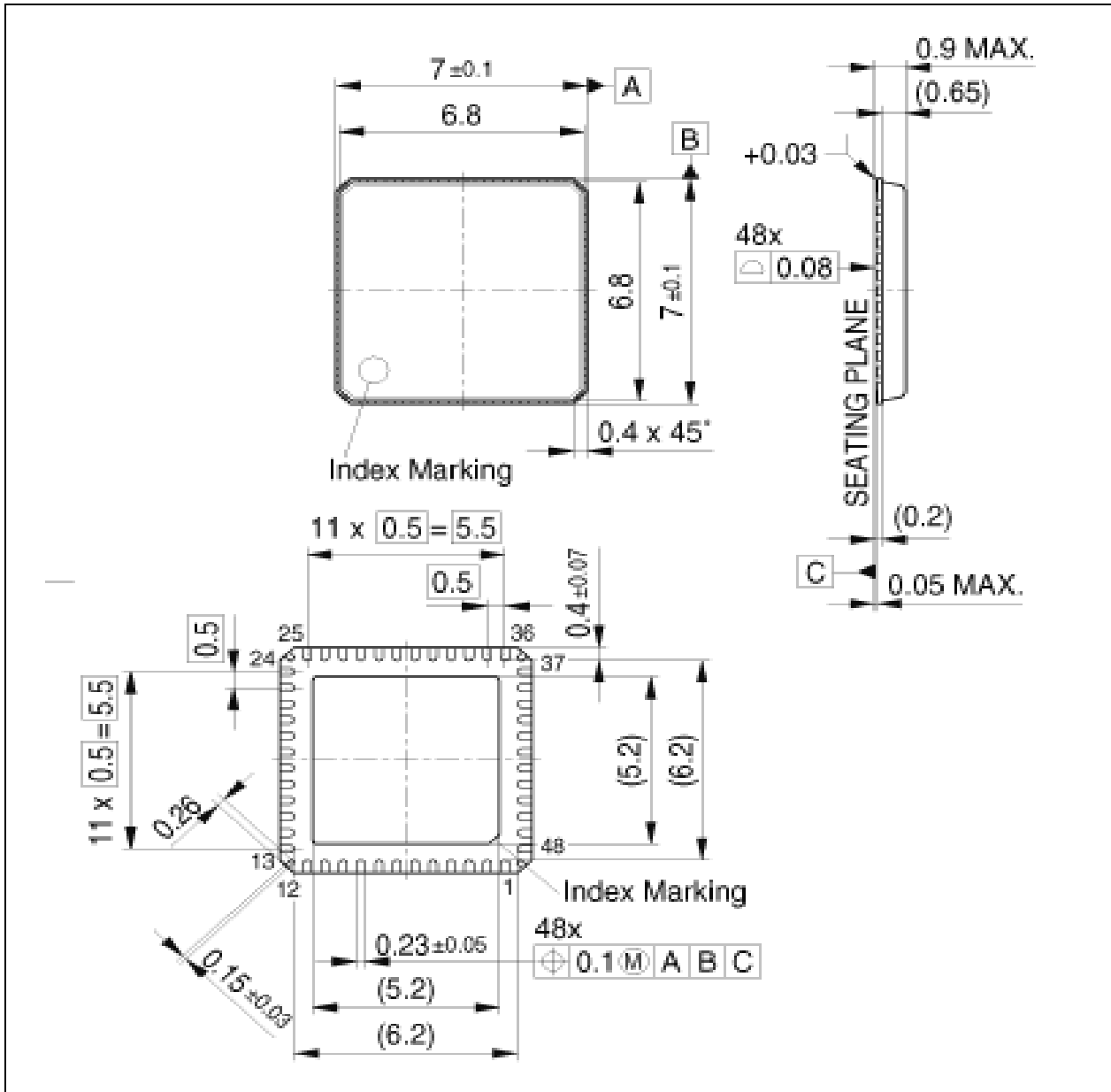

Figure 48 PG-VQFN-48-22 Package Outline

5.3 Quality Declaration

Table 57 shows the characteristics of the quality parameters in the XC87x.

Table 57 Quality Parameters

Parameter	Symbol	Limit Values		Unit	Notes
		Min.	Max.		
Operation Lifetime when the device is used at the two stated T_J ¹⁾	t_{OP1}	-	15000	hours	$T_J = 110^\circ\text{C}$
		-	2000	hours	$T_J = -40^\circ\text{C}$
Operation Lifetime when the device is used at the five stated T_J ¹⁾	t_{OP2}	-	120	hours	$T_J = 140^\circ\text{C}$
		-	960	hours	$T_J = 135^\circ\text{C}$
		-	7800	hours	$T_J = 91^\circ\text{C}$
		-	2400	hours	$T_J = 38^\circ\text{C}$
		-	720	hours	$T_J = -25^\circ\text{C}$
ESD susceptibility according to Human Body Model (HBM)	V_{HBM}	-	2000	V	Conforming to EIA/JESD22-A114-B
ESD susceptibility according to Charged Device Model (CDM) pins	V_{CDM}	-	750	V	Conforming to JESD22-C101-C



1) This lifetime refers only to the time when device is powered-on.

www.infineon.com

Published by Infineon Technologies AG

Looking for pricing, stock, or lifecycle information?

Click below to explore more details on WIN SOURCE:

-  [View C3216X5R0J336M130AC on WIN SOURCE](#)
-  [TDK Corporation Information](#)

Optimize Your Supply Chain with WIN SOURCE Solutions

-  Global Sourcing Solution
-  Obsolete Management
-  Cost Control Management
-  Shortage Management
-  Alternative Solution
-  Excess Inventory Management