

STRUCTURE Silicon Monolithic Integrated Circuit
 TYPE Single Channel Series Regulator Driver IC
 PRODUCT SERIES **BD3521FVM**
 FEATURES
 • Non Rush Current on Start up (NRCS)
 • N channel MOSFET driver
 • Output Voltage : 1.5V (±1%)

○ ABSOLUTE MAXIMUM RATINGS (Ta=25°C)

Parameter	Symbol	Limit	Unit
Supply Voltage	VCC	7 ^{*1}	V
Drain Voltage (VIN)	VD	7	V
Enable Input Voltage	Ven	7	V
Power Dissipation	Pd	437.5 ^{*2}	mW
Operating Temperature Range	Topr	-10~+100	°C
Storage Temperature Range	Tstg	-55~+150	°C
Maximum Junction Temperature	Tjmax	+150	°C

*1 Operating temperature range should not exceed Tjmax=150°C

*2 Pd derating at 3.5mW/°C for temperature above Ta=25°C

○ RECOMMENDED OPERATING CONDITIONS (Ta=25°C)

PARAMETER	SYMBOL	MIN	MAX	UNIT
Supply Voltage	VCC	4.5	5.5	V
Drain Voltage (VIN)	VD	1.5	5.5	V
Enable Input Voltage	Ven	-0.3	5.5	V
Capacitor on NRCS Terminal	CNRCS	0.001	1	uF

★ This product is not designed for protection against radioactive rays.

○ ELECTRICAL CHARACTERISTICS

(Unless otherwise specified, Ta=25°C VCC=5V VIN=3.3V Ven=3V)

PARAMETER	SYMBOL	LIMIT			UNIT	CONDITIONS
		MIN	TYP	MAX		
Bias Current	ICC	-	0.85	1.7	mA	
Shut Down Mode Current	IST	-	0	10	uA	Ven=0V
Output Voltage 1	Vo1	1.485	1.500	1.515	V	Io=50mA
Output Voltage 2	Vo2	1.470	1.500	1.530	V	Vcc=4.5V to 5.5V , Ta=-10°C to 100°C(※)
Line Regulation	Reg.I	-	0.1	0.5	%/V	VCC=4.5V to 5.5V
Load Regulation	Reg.L	-	0.5	10	mV	Io=0 to 3A
[Enable]						
High Level Enable Input Voltage	Enhi	2	-	Vcc	V	
Low Level Enable Input Voltage	Enlow	-0.3	-	0.8	V	
Enable pin Input Current	Ien	-	7	10	uA	Ven=3V
[Source Voltage]						
VS Input Bias Current	ISBIAS	-	1.2	2.4	mA	
VS Standby Current	ISSTB	150	-	-	mA	VS=1V Ven=0V
[Output MOSFET Driver]						
MOSFET Driver Source Current	IGSO	2	3	4	mA	VFB=1.4V, VGATE=2.5V
MOSFET Driver Sink Current	IGSI	2	3	4	mA	VFB=1.6V, VGATE=2.5V
[UVLO]						
VCC UVLO	VccUVLO	4.20	4.35	4.50	V	Vcc:Sweep up
VCC UVLO Hysteresis	Vcchys	100	160	220	mV	Vcc:Sweep down
VD UVLO	VDUVLO	Vo × 0.6	Vo × 0.7	Vo × 0.8	V	VD:Sweep up
[Drain Voltage Sensing]						
VD Input bias Current	Ivd	7	13	19	uA	VD=3.3V
[NRCS/SCP]						
NRCS Charge Current	Inrcs	14	20	26	uA	VNRCS=0.5V
SCP Charge Current	Iscpch	14	20	26	uA	VNRCS=0.5V
SCP Discharge Current	IscpDi	0.3	-	-	mA	VNRCS=0.5V
SCP Threshold Voltage	Vscp	1.2	1.3	1.4	V	
Short Detect Voltage	Voscp	Vo × 0.3	Vo × 0.35	Vo × 0.4	V	
NRCS Stand-by Voltage	VSTB	-	-	50	mV	

(※) Design Guarantee

○ PHYSICAL DIMENSIONS

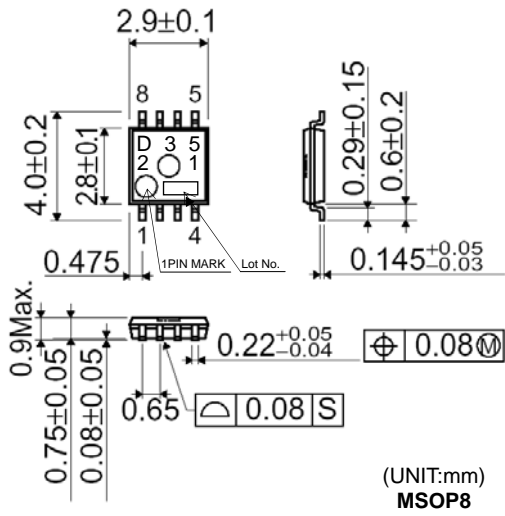

○ BLOCK DIAGRAM

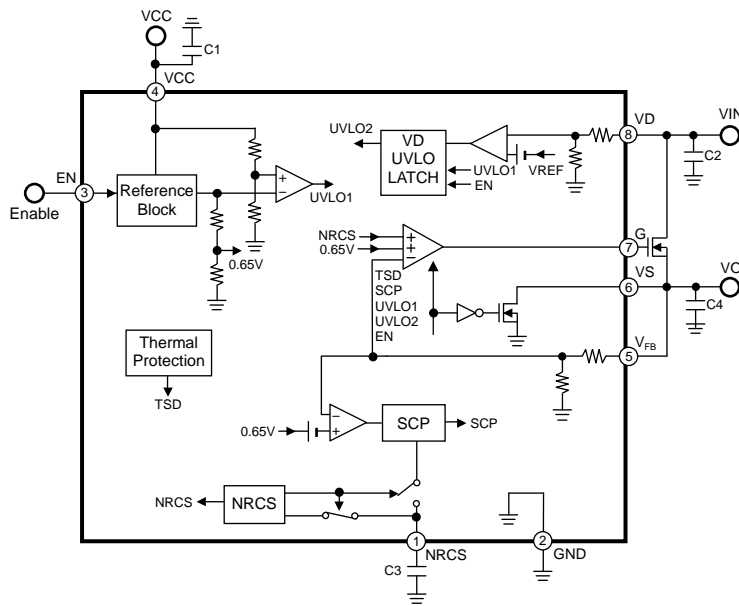

○ Pin number Pin name

PIN No.	PIN Name
1	NRCS
2	GND
3	EN
4	VCC
5	VFB
6	VS
7	G
8	VD

ONOTES FOR USE

- (1) Absolute maximum range
Although the quality of this product is rigorously controlled, and circuit operation is guaranteed within the operation ambient temperature range, the device may be destroyed when applied voltage or operating temperature exceeds its absolute maximum rating. Because the failure mode (such as short mode or open mode) cannot be identified in this instance, it is important to take physical safety measures such as fusing if a specific mode in excess of absolute rating limits is considered for implementation.
- (2) Ground potential
Make sure the potential for the GND pin is always kept lower than the potentials of all other pins, regardless of the operating mode, including transient conditions.
- (3) Thermal Design
Provide sufficient margin in the thermal design to account for the allowable power dissipation (Pd) expected in actual use.
- (4) Using in the strong electromagnetic field
Use in strong electromagnetic fields may cause malfunctions.
- (5) ASO
Be sure that the output transistor for this IC does not exceed the absolute maximum ratings or ASO value.
- (6) Thermal Protection Circuit
A thermal shutdown circuit (T.S.D) is built into the IC to prevent damage due to overheating. Therefore, all the outputs are turned off when the T.S.D circuit is activated. (This IC latches output to off mode when the temperature recedes to the specified level. To release latch mode, EN or UVLO is re-operated.) However, the T.S.D circuit is used only for extreme conditions, and the regulator circuit should still be designed for the IC not to exceed $T_j(\text{max})=150^{\circ}\text{C}$.
- (7) GND pattern
When both a small-signal GND and high current GND are present, single-point grounding (at the set standard point) is recommended, in order to separate the small-signal and high current patterns, and to be sure the voltage change stemming from the wiring resistance and high current does not cause any voltage change in the small-signal GND. In the same way, care must be taken to avoid wiring pattern fluctuations in any connected external component GND.
- (8) Output Capacitor (C4)
Mount an output capacitor between VS and GND for stability purposes. The output capacitor is for the open loop gain phase compensation and reduces the output voltage load regulation. If the capacitor value is not large enough, the output voltage may oscillate. And if the equivalent series resistance (ESR) is too large, the output voltage rise/drop increases during a sudden load change. A 220uF polymer capacitor is recommended. However, the stability depends on the characteristics of temperature, load, the gate capacitance of the external MOSFET, and the mutual conductance (gm). And if a small ESR capacitor such as a ceramic capacitor is utilized (several kind of capacitors are utilized in parallel), the output voltage may oscillate due to lack of phase margin. In this case, measures can be taken by adding a capacitor and a resistor in series with this capacitor between the gate of MOSFET and GND. Please confirm operation across a variety of temperature, load conditions, and MOSFET characteristics.
- (9) Input Capacitor (C1, C2)
The input capacitor reduces the output impedance of the voltage supply source connected in the VCC and VIN. If the output impedance of this power supply increases, the input voltage (VCC,VIN) may become unstable. This may result in the output voltage oscillation or lowering ripple rejection. A low ESR 10uF capacitor with minimal susceptibility to temperature is preferable, but stability depends on power supply characteristics, the substrate wiring pattern, and the parasitic capacitor between Gate and Drain of MOSFET. Please confirm operation across a variety of temperature, load, and MOSFET conditions.
- (10) NRCS (Non Rush Current on Start-up) Setting (C3)
The NRCS function is built in this IC to prevent rush current from going through the load (VIN to Vo) for start-up. The constant current comes from the NRCS pin when EN is high or UVLO function is deactivated. Temporary reference voltage is made proportional to time due to current charge the NRCS pin capacitor and make output voltage start up proportional to this reference voltage.
Timer latch short circuit protection function is built in this IC (NRCS is also working at the same time.) to protect the breakdown of the power MOSFET caused by rush current when the output is shorted to GND. This function becomes active when the output voltage level goes under by 30% of specified Vout. The constant current comes from the NRCS pin in this case. When the reference voltage made by the current charge of the NRCS pin hits 1.3V (Typ.), the gate voltage becomes low. To obtain a stable SCP delay time, a capacitor (B) with susceptibility to temperature is recommended.
- (11) Input Terminal (VCC,VD,EN)
The EN, VD, and VCC are isolated. The UVLO protects incorrect operation when the voltage level of VD and VCC are low. The output becomes high when these pins reach the individual threshold level independent of the start-up pin order. However, if VIN shut down while the IC works under the normal operation, SCP function becomes active and latches the status. And the output does not come back active even though VIN goes up high again. In this case, start VCC or EN up again to deactivate this latch function.
- (12) Maximum Output Current (Maximum Load)
The maximum output current of the power supply utilizing the IC depends on external MOSFET. The MOSFET should be chosen based on a required power supply characteristics for an actual application.
- (13) Please add a protection diode when a large inductance component is connected to the output terminal, and reverse-polarity power is possible at startup or in output OFF condition.

(Example)

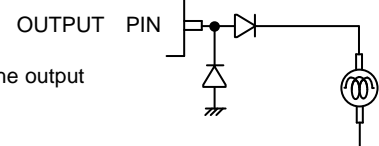

Notes

No copying or reproduction of this document, in part or in whole, is permitted without the consent of ROHM Co.,Ltd.

The content specified herein is subject to change for improvement without notice.

The content specified herein is for the purpose of introducing ROHM's products (hereinafter "Products"). If you wish to use any such Product, please be sure to refer to the specifications, which can be obtained from ROHM upon request.

Examples of application circuits, circuit constants and any other information contained herein illustrate the standard usage and operations of the Products. The peripheral conditions must be taken into account when designing circuits for mass production.

Great care was taken in ensuring the accuracy of the information specified in this document. However, should you incur any damage arising from any inaccuracy or misprint of such information, ROHM shall bear no responsibility for such damage.

The technical information specified herein is intended only to show the typical functions of and examples of application circuits for the Products. ROHM does not grant you, explicitly or implicitly, any license to use or exercise intellectual property or other rights held by ROHM and other parties. ROHM shall bear no responsibility whatsoever for any dispute arising from the use of such technical information.

The Products specified in this document are intended to be used with general-use electronic equipment or devices (such as audio visual equipment, office-automation equipment, communication devices, electronic appliances and amusement devices).

The Products specified in this document are not designed to be radiation tolerant.

While ROHM always makes efforts to enhance the quality and reliability of its Products, a Product may fail or malfunction for a variety of reasons.

Please be sure to implement in your equipment using the Products safety measures to guard against the possibility of physical injury, fire or any other damage caused in the event of the failure of any Product, such as derating, redundancy, fire control and fail-safe designs. ROHM shall bear no responsibility whatsoever for your use of any Product outside of the prescribed scope or not in accordance with the instruction manual.

The Products are not designed or manufactured to be used with any equipment, device or system which requires an extremely high level of reliability the failure or malfunction of which may result in a direct threat to human life or create a risk of human injury (such as a medical instrument, transportation equipment, aerospace machinery, nuclear-reactor controller, fuel-controller or other safety device). ROHM shall bear no responsibility in any way for use of any of the Products for the above special purposes. If a Product is intended to be used for any such special purpose, please contact a ROHM sales representative before purchasing.

If you intend to export or ship overseas any Product or technology specified herein that may be controlled under the Foreign Exchange and the Foreign Trade Law, you will be required to obtain a license or permit under the Law.



Thank you for your accessing to ROHM product informations.
More detail product informations and catalogs are available, please contact us.

ROHM Customer Support System

<http://www.rohm.com/contact/>

Looking for pricing, stock, or lifecycle information?

Click below to explore more details on WIN SOURCE:

-  [View BD3521FVM-TR on WIN SOURCE](#)
-  [Rohm Semiconductor](#) Information

Optimize Your Supply Chain with WIN SOURCE Solutions

-  Global Sourcing Solution
-  Obsolete Management
-  Cost Control Management
-  Shortage Management
-  Alternative Solution
-  Excess Inventory Management