



**THE DATASHEET OF  
BQ20Z70EVM-001**



# ***bq20z70EVM-001 SBS 1.1 Impedance Track™ Technology Enabled Battery Management Solution Evaluation Module***

This EVM is a complete evaluation system for the bq20z70/bq29330/bq29412 battery management system. The EVM includes one bq20z70/bq29330/bq29412 circuit module, a current sense resistor, two thermistors, and Windows®-based PC software. The circuit module includes one bq20z70 IC, one bq29330 IC, one bq29412 IC, and all other onboard components necessary to monitor and predict capacity, perform cell balancing, monitor critical parameters, protect the cells from overcharge, over discharge, short circuit, and overcurrent in 2-, 3- or 4-series cell Li-ion or Li-polymer battery packs. The circuit module connects directly across the cells in a battery. An EV2300 board for gas gauge interface is required to interface this EVM with the PC and can be purchased separately. With the EV2300 interface board and software, the user can read the bq20z70 data registers, program the chipset for different pack configurations, log cycling data for further evaluation, and evaluate the overall functionality of the bq20z70/bq29330/bq29412 solution under different charge and discharge conditions.

### Contents

1	Features .....	2
2	bq20z70/bq29330-Based Circuit Module .....	2
3	bq20z70/bq29330 Circuit Module Schematic .....	3
4	Circuit Module Physical Layouts and Bill of Materials .....	3
5	EVM Hardware and Software Setup .....	9
6	Troubleshooting Unexpected Dialog Boxes .....	9
7	Hardware Connection .....	9
8	Operation .....	11
9	Calibration Screen .....	14
10	Pro (Advanced) Screen .....	16
11	Related Documentation from Texas Instruments .....	17

### List of Figures

1	bq20z70EVM-001 Layout (Silk Screen).....	4
2	Top Assembly .....	4
3	Top Layer .....	4
4	Bottom Layer .....	5
5	Bottom Assembly .....	5
6	Schematic.....	8
7	bq20z70/bq29330 Circuit Module Connection to Cells and System Load/Charger.....	10
8	SBS Data Screen.....	12
9	Data Flash Screen, 1st Level Safety Class .....	13
10	Calibration Screen.....	15
11	Pro (Advanced) Screen.....	16

### List of Tables

1	Ordering Information.....	2
2	Bill of Materials .....	6

Impedance Track is a trademark of Texas Instruments.  
Windows is a registered trademark of Microsoft Corporation.

3	Performance Specification Summary.....	9
4	Circuit Module to EV2300 Connections .....	10

## 1 Features

- Complete evaluation system for the bq20z70 SBS 1.1-compliant advanced gas gauge with Impedance Track Technology, bq29330 analog front end (AFE) and protection IC, and bq29412 independent overvoltage protection IC
- Populated circuit module for quick setup
- PC software and interface board for easy evaluation
- Software that allows data logging for system analysis

### 1.1 Kit Contents

- bq20z70/bq29330/bq29412 circuit module
- Software CD with the evaluation software
- Set of support documentation

### 1.2 Ordering Information

**Table 1. Ordering Information**

EVM PART NUMBER	CHEMISTRY	CONFIGURATION	CAPACITY
bq20z70EVM-001	Li-ion	2, 3, or 4 cell	Any

## 2 bq20z70/bq29330-Based Circuit Module

The bq20z70/bq29330/bq29412-based circuit module is a complete and compact example solution of a bq20z70 and bq29330 circuit for battery management and protection of Li-ion or Li-polymer packs. The circuit module incorporates a bq20z70 battery monitor IC, bq29330 AFE and protection IC, bq29412 independent overvoltage protection IC, and all other components necessary to accurately predict the capacity of 2-, 3-, or 4-series cells.

### 2.1 Circuit Module Connections

Contacts on the circuit module provide the following connections:

- Direct connection to the cells: 1N (BAT-), 1P, 2P, 3P, 4P (BAT+)
- To the serial communications port (SMBC, SMBD, VSS)
- The system load and charger connect across PACK+ and PACK-
- To the system present pin (SYS PRES)

## 2.2 Pin Descriptions

PIN NAME	DESCRIPTION
1N	–ve connection of first (bottom) cell
1P	+ve connection of first (bottom) cell
2P	+ve connection of second cell
3P	+ve connection of third cell
4P	+ve connection of fourth (top) cell
SMBC	Serial communication port clock
SMBD	Serial communication data port
VSS	Pack negative terminal
PACK–	Pack negative terminal
SYS PRES	System present pin (if low, system is present)
PACK+	Pack positive terminal

## 3 bq20z70/bq29330 Circuit Module Schematic

This section contains information for modifying and choosing a precharge mode for bq20z70/bq29330/bq29412 implementation.

### 3.1 Schematic

The schematic follows the bill of materials in this user's guide.

### 3.2 Choosing Particular Precharge Mode

The chipset supports both a charger that has a precharge mode and one that does not. The EVM by default supports a charger that does not have a precharge mode. This is configured by grounding the PMS pin with a resistor. R12 and Q2 are used as the precharge current path in order to sustain sufficient Pack+ voltage when the battery voltage is too low to power up the bq29330 IC.

If the charger has a precharge function, R12 and FET Q2 are not used. The PMS pin must be pulled high to disable ZVCHG output. The charge FET Q1 is used as the precharge FET, and the charger must control the precharge current and voltage.

Note: The configuration at PMS pin is a hardware level control. Once the bq20z70 is up and running, the firmware may change the precharge settings. Please refer to bq20z70 datasheet for further information.

### 3.3 Testing Fuse-Blowing Circuit

To prevent the loss of board functionality during the fuse-blowing test, the actual chemical fuse is not provided in the circuit. FET Q4 drives TP3 low if a fuse-blow condition occurs; so monitoring TP3 can be used to test this condition.

## 4 Circuit Module Physical Layouts and Bill of Materials

This section contains the board layout, bill of materials, and assembly drawings for the bq20z70/ bq29330/ bq29412 circuit module.

---

**NOTE:** For the battery pack designer: D3 is not recommended, and should be shorted out if the DSG FET does not have built-in zener diode protection.

---

## 4.1 Board Layout

This section shows the dimensions, PCB layers, and assembly drawing for the bq20z70/bq29330 module.

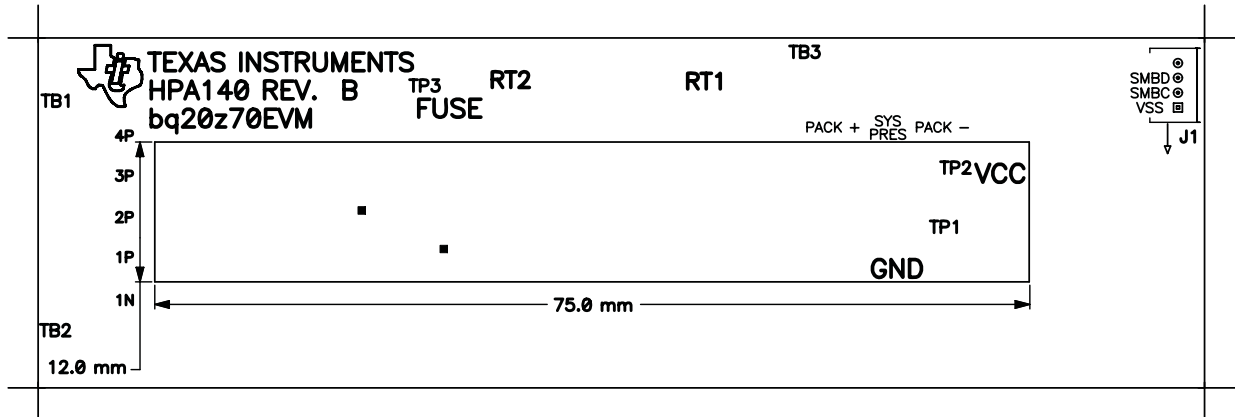

Figure 1. bq20z70EVM-001 Layout (Silk Screen)

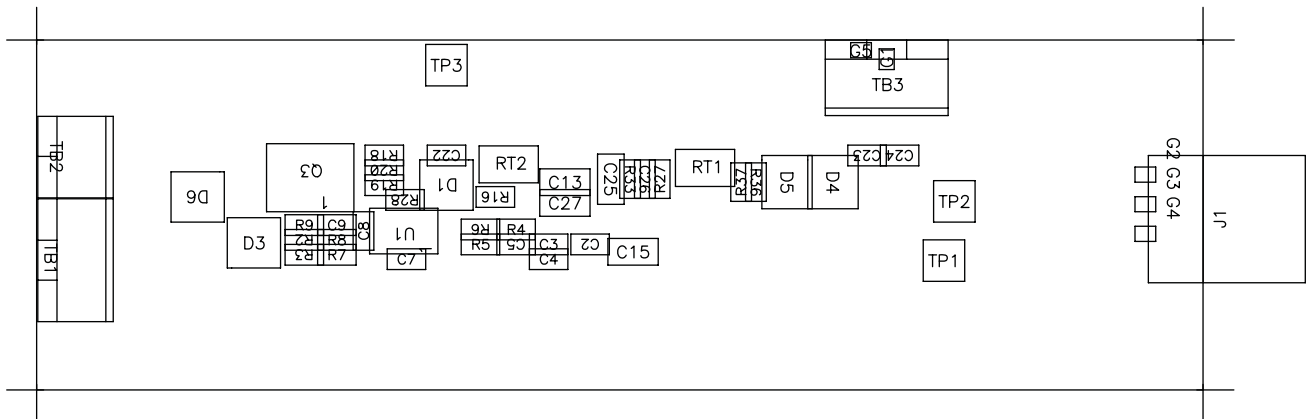

Figure 2. Top Assembly

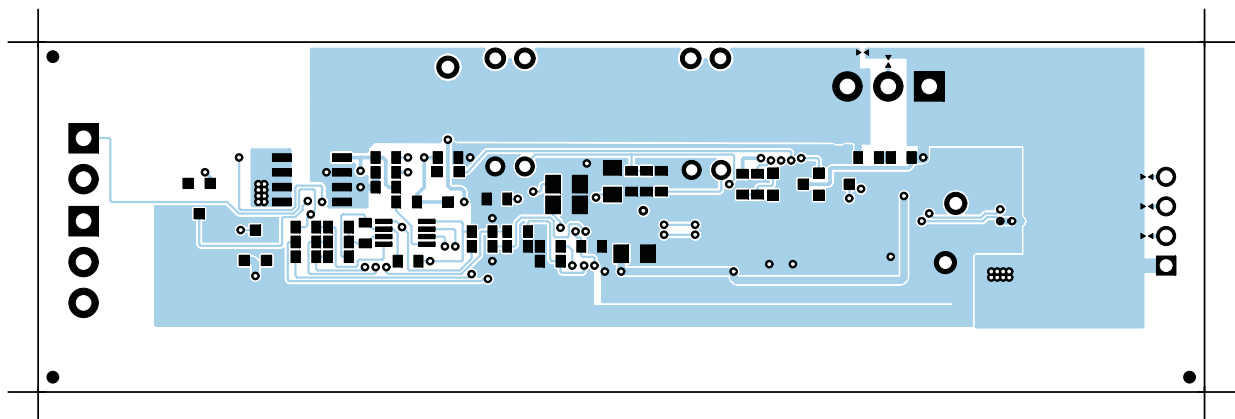
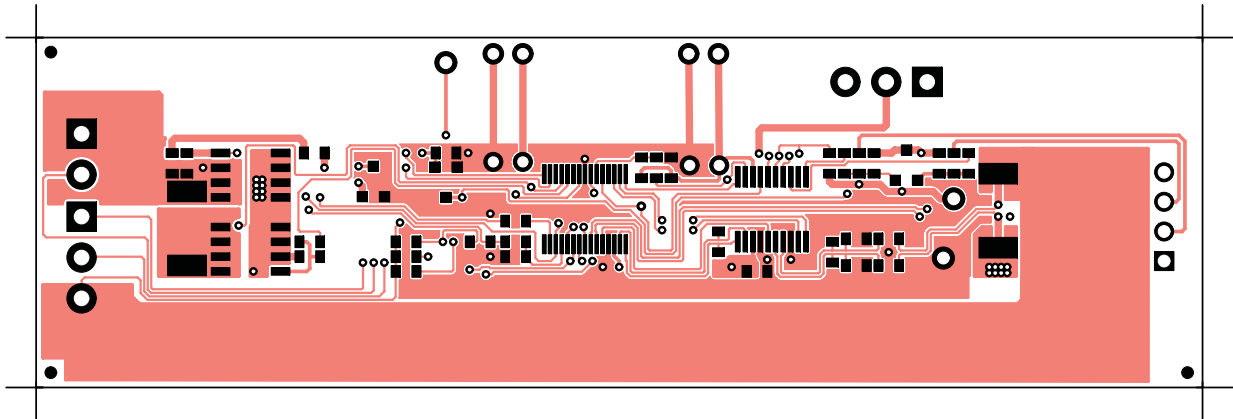
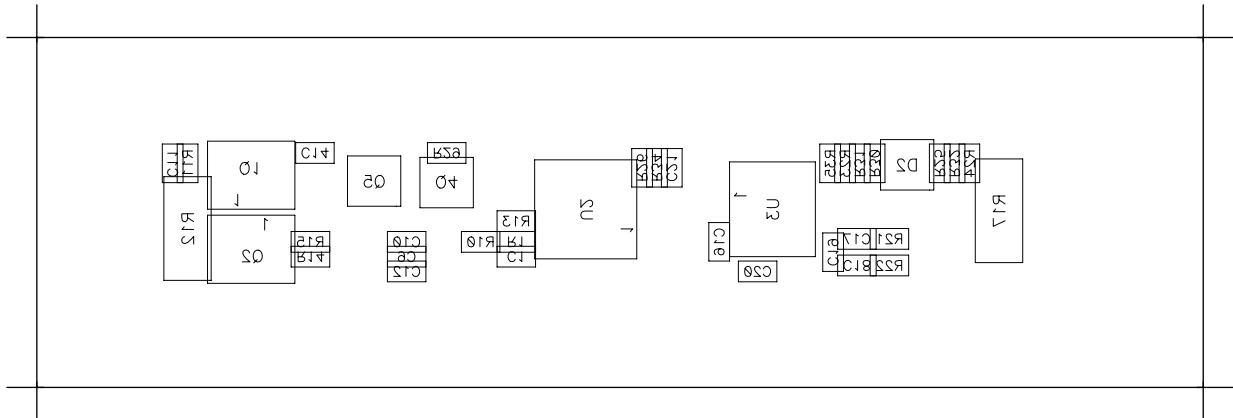

Figure 3. Top Layer



**Figure 4. Bottom Layer**



**Figure 5. Bottom Assembly**

## 4.2 Bill of Materials

**Table 2. Bill of Materials**

Count	Ref Des	Value	Description	Size	Part No.	MFR
20	C1–C11, C14, C16–C20, C22–C24	0.1 $\mu$ F	Capacitor, ceramic, 0.1 $\mu$ F, 50 V, X7R, 20%	0603	STD	Any
1	C12	0.22 $\mu$ F	Capacitor, ceramic, 0.22 $\mu$ F, 25 V, X7R, 20%	0603	STD	Any
3	C13, C15, C27	1.0 $\mu$ F	Capacitor, ceramic, 1.0 $\mu$ F, 25 V, X7R, 20%	0805	STD	Any
2	C21, C26	0.47 $\mu$ F	Capacitor, ceramic, 0.47 $\mu$ F, 16 V, X7R, 20%	0603	STD	Any
1	C25	2.2 $\mu$ F	Capacitor, ceramic, 2.2 $\mu$ F, 10 V, X7R, 20%	0805	STD	Any
4	D1, D3, D4, D6	BAS16	Diode, Switching, 150-mA, 75-V, 350 mW	SOT23	BAS16	Vishay-Liteon
2	D2, D5	AZ23C5V6	Diode, dual, zener, 5.6V, 300mW	SOT23	AZ23C5V6	Vishay-Telefunken
1	J1	22-05-3041	Header, friction lock assembly, 4-pin right angle	0.400 x 0.500	22-05-3041	Molex
2	Q1, Q3	FDS6690A	MOSFET, N-ch, Logic Level, Power Trench, 30 V, 11 A, 12.5 m $\Omega$	SO8	FDS6690A	Fairchild
1	Q2	Si4435DY	MOSFET, P-ch, 30 V, 8 A, 20 m $\Omega$	SO8	Si4435DY	Siliconix
1	Q4	NDS331N	MOSFET, N-ch, 20 V, 1.3 A, 0.16 $\Omega$	SOT23	NDS331N	Fairchild
1	Q5	BSS138	MOSFET, N-ch, 50 V, 0.22 A, 6 $\Omega$	SOT23	BSS138	Fairchild
12	R1–R5, R21–R24, R31, R32, R36	100	Resistor, chip, 100 $\Omega$ , 1/16 W, 5%	0603	STD	STD
2	R11, R19	3M	Resistor, chip, 3 M $\Omega$ , 1/16 W, 5%	0603	STD	STD
1	R12	301	Resistor, chip, 301 $\Omega$ , 1 W, 1%	2512	WSL-2512-301	Vishay
3	R13, R15, R18	5.1K	Resistor, chip, 5.1 k $\Omega$ , 1/16 W, 5%	0603	STD	STD
3	R14, R25, R30	1M	Resistor, chip, 1 M $\Omega$ , 1/16 W, 5%	0603	STD	STD
1	R16	100K	Resistor, chip, 100 k $\Omega$ , 1/16 W, 5%	0603	STD	STD
1	R17	0.010 75ppm	Resistor, chip, 0.010 $\Omega$ , 1 W, 1%	2512	WSL-2512-010	Vishay
1	R20	10K	Resistor, chip, 10 k $\Omega$ , 1/16 W, 5%	0603	STD	STD
2	R26, R34	8.45K	Resistor, chip, 8.45 k $\Omega$ , 1/16 W, 1%	0603	STD	STD
2	R27, R33	61.9K	Resistor, chip, 61.9 k $\Omega$ , 1/16 W, 1%	0603	STD	STD
3	R28, R29, R35	220K	Resistor, chip, 220 k $\Omega$ , 1/16 W, 5%	0603	STD	STD
6	R6–R10, R37	1K	Resistor, Chip 1 k $\Omega$ , 1/16W, 5%	0603	STD	STD
2	RT1, RT2	10K	Thermistor, 10 k $\Omega$	0.095 x 0.150	NTC103AT	Sematec
2	TB1, TB3	ED1515	Terminal block, 3 pin, 6 A, 3.5 mm	0.41 x 0.25	ED1515	OST
1	TB2	ED1514	Terminal block, 2 pin, 6 A, 3.5 mm	0.27 x 0.25	ED1514	OST
1	TP1	GND	Test point, White, Thru Hole Color Keyed	0.100 x 0.100 in	5002	Keystone
1	TP2	VCC	Test point, White, Thru Hole Color Keyed	0.100 x 0.100 in	5002	Keystone
1	TP3	~FUUSE	Test point, White, Thru Hole Color Keyed	0.100 x 0.100 in	5002	Keystone
1	U1		IC, voltage protection for 2, 3, or 4 cell Li-Ion, 2nd protection, 4.45 OVP $\pm$ 25 mV	MSOP-08 (DCT3)	BA29412DT3R	TI
1	U2		IC, 2, 3, or 4 cell series protection control AFE	TSSOP-30	bq29330DBT	TI
1	U3		IC, SBS 1.1-Compliant GG Enabled with Impedance Track™ technology, use with the bq29330	TSSOP-20	bq20z70PW	TI
<b>Connector</b>						
2	J5 mate	Connector, Female, 0.100 centers			Molex	22-01-3407
8	N/A	Terminals, crimp, tin			Molex	08-50-0114
	N/A	Wire, insulated 24 AWG. red, 18 inches ( $\pm$ 3 inches) (USB_5V)			Alpha	1854-3
	N/A	Wire, insulated 24 AWG. white, 18 inches ( $\pm$ 3 inches) (SCL)			Alpha	1854-1
	N/A	Wire, insulated 24 AWG. black, 18 inches ( $\pm$ 3 inches) (GND)			Alpha	1854-2
	N/A	Wire, insulated 24 AWG. brown, 18 inches ( $\pm$ 3 inches) (SDA)			Alpha	1854-7
1	N/A	Heatsink, 1 inch			Any	Any
<b>Notes:</b>						
1. These assemblies are ESD sensitive; observe ESD precautions.						
2. This assembly must be clean and free from flux and all contaminants. Use of no clean flux is not acceptable.						

**Table 2. Bill of Materials (continued)**

Count	Ref Des	Value	Description	Size	Part No.	MFR
3.			This assembly must comply with workmanship standards IPC-A-610 Class 2.			
4.			Reference designators marked with an asterisk (**) cannot be substituted. All other components can be substituted with equivalent MFG's components.			
5.			<p>Make one SMBus connector wire assembly for each assembly produced, from J5 mate, 4-24 AWG wires, and crimp terminals. Wire colors for pin numbers are listed below. The wire assembly shall have a J5 mate on each end.</p> <ul style="list-style-type: none"> <li>• Red – Pin 4 (Signal USB_5V)</li> <li>• Brown – Pin 3 (Signal Data)</li> <li>• White – Pin 2 (Signal Clock)</li> <li>• Black – Pin 1 (GND)</li> </ul>			
6.			RT1/RT2 should be assembled horizontally laying flat against the board edge with the sensing tip out.			

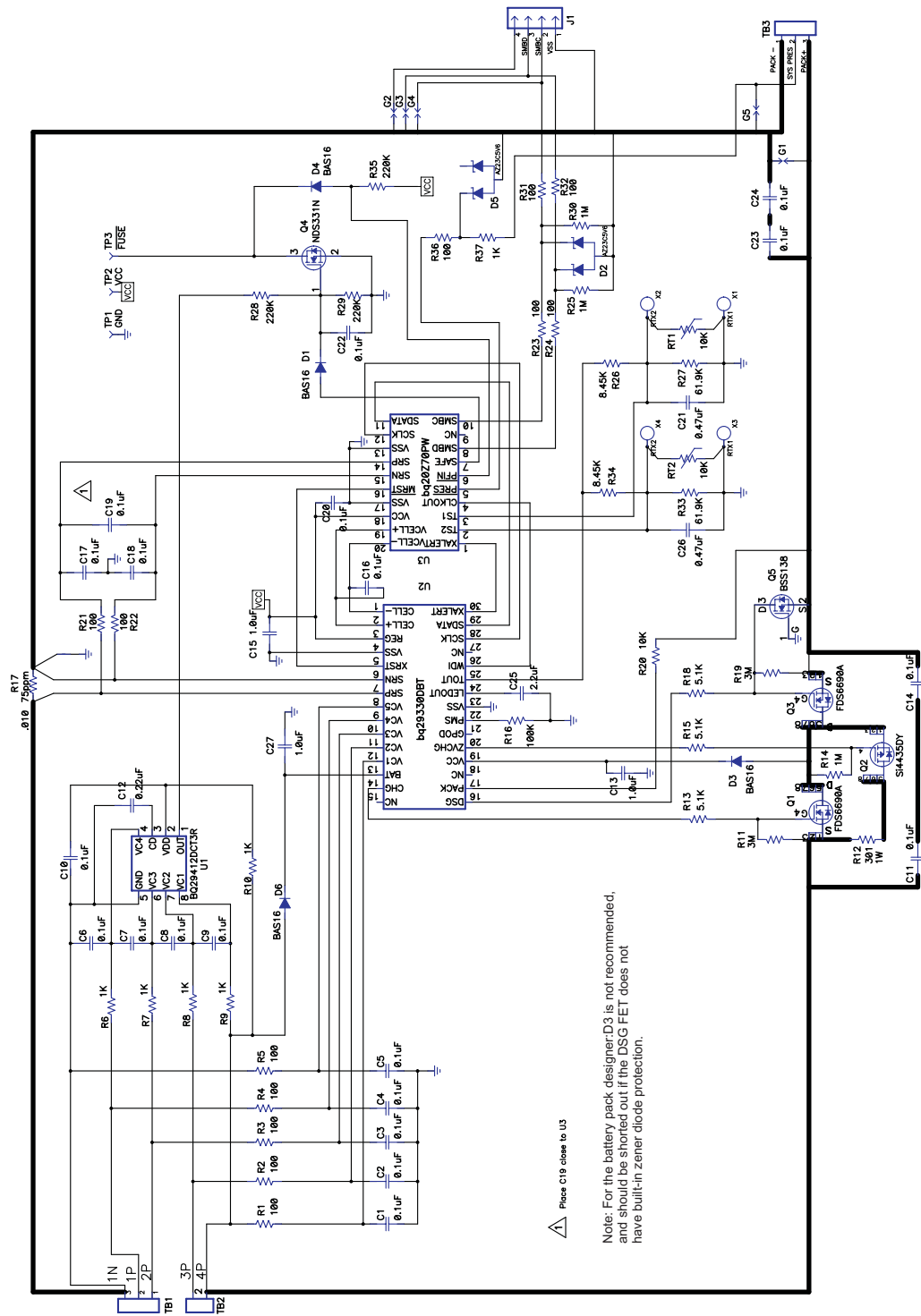

Figure 6. Schematic

### 4.3 bq20z70/bq29330/bq29412 Circuit Module Performance Specification Summary

This section summarizes the performance specifications of the bq20z70/ bq29330/bq29412 circuit module.

**Table 3. Performance Specification Summary**

Specification	Min	Typ	Max	Units
Input voltage Pack+ to Pack-	6	15	25	V
Charge and discharge current	0	2	7	A

## 5 EVM Hardware and Software Setup

This section describes how to install the bq20z70EVM-001 PC software, and how to connect the different components of the EVM.

### 5.1 System Requirements

The bq20z70EVSUW requires Windows 2000 or Windows XP. Drivers for Windows 98SE are provided, but Microsoft no longer supports Windows 98; and there may be issues in Windows 98 with USB driver support. The EV2300 USB drivers have been tested for Windows 98SE, but no assurance is made for problem-free operation with specific system configurations.

### 5.2 Software Installation

Find the latest software version in the bq20z70 tool folder on [power.ti.com](http://power.ti.com). Use the following steps to install the bq20z70EVSUW software:

1. Copy the files from the CD into the temporary directory you selected, in the folder "bq20z70 EV SW Install", double-click on *bqEVSUWSetup00.09.32.exe* and follow the installer instructions to complete the bq20z70 EVSUW installation.
2. If the EV2300 was not previously installed, after bq20z70 EVSUW installation, a TI USB DRIVER INSTALLER will pop up. Click "Yes" for the agreement message and follow its instructions.
3. Plug the EV2300 into a USB port.
4. The Win98 Driver can be found in the archive Win98EV2300Drivers-DocUpdateDec1703.zip under the "EV2300 Drivers" folder.

If files were downloaded from the Web:

1. Open the archive containing the installation package, and copy its contents in a temporary directory.
2. Follow the preceding steps 1 - 4.

## 6 Troubleshooting Unexpected Dialog Boxes

Ensure that the files were extracted from the zip file using the *Preserve Folder names* option.

Ensure that all the files were extracted from the zip file.

The user that is downloading the files must be logged in as the administrator.

The driver is not signed, so the administrator must allow installation of unsigned drivers in the operating system policy.

## 7 Hardware Connection

The bq20z70EVM-001 comprises three hardware components: the bq20z70/bq29330/bq29412 circuit module, the EV2300 PC interface board (purchased separately), and the PC.

## 7.1 Connecting the bq20z70/bq29330/bq29412 Circuit Module to a Battery Pack

Figure 7 shows how to connect the bq20z70/bq29330/bq29412 circuit module to the cells and system load/charger.

The cells should be connected in the following order:

1. 4-Cell Pack: 1N (BAT-), 1P, and 2P (see Section 2.1 for definitions).
2. 3-Cell Pack: 1N (BAT-), 1P, 2P, and then connect 4P and 3P together.
3. 2-Cell Pack: 1N (BAT-), 1P, and then connect 4P, 3P, and 2P together

To start charge or discharge test, connect SYS PRES pin to PACK- pin to set SYS PRES state. To test sleep mode, disconnect the SYS PRES pin.

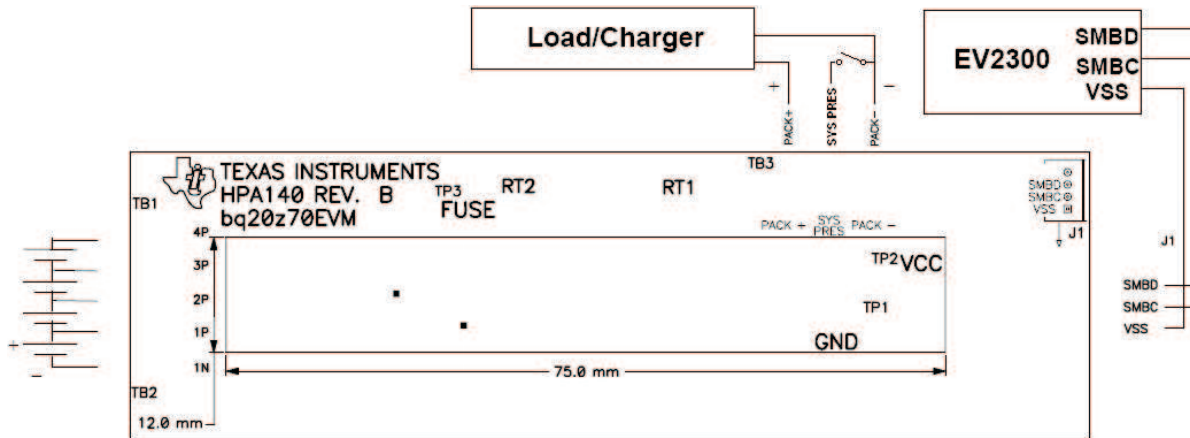

Figure 7. bq20z70/bq29330 Circuit Module Connection to Cells and System Load/Charger

## 7.2 PC Interface Connection

The following steps configure the hardware for interface to the PC:

1. Connect the bq20z70/bq29330-based smart battery to the EV2300 using wire leads as shown in Table 4.

Table 4. Circuit Module to EV2300 Connections

bq20z70/bq29330-Based Battery	EV2300
SMBD	SMBD
SMBC	SMBC
VSS	GND

2. Connect the PC USB cable to the EV2300 and the PC USB port.

The bq20z70EVM-001 is now set up for operation.

## 8 Operation

This section details the operation of the bq20z70 EVSW software. Note: the EV2300 driver does not support Windows Sleep or Hibernate. In case there is a problem communicating with the EV2300 or the EVM, first unplug the USB cable then plug it back in. If the problem persists, check whether the EVM is in Shutdown mode. The bq20z70 can be waken up by momentarily applying a voltage higher than 5.5V (but less than 25V) at Pack+ pin of the EVM.

### 8.1 Starting the Program

With the EV2300 and the bq20z70 EVM connected to the computer, run bq20z70 EVSW from the Start | Programs | Texas Instruments | bq20z70 EVSW menu sequence. The SBS Data screen appears. Data begins to appear once the <Refresh> (single time scan) button is clicked, or when the <Keep Scanning> check box is checked. To disable the scan feature, deselect <Keep Scanning>.

The continuous scanning period can be set via the |Options| and |Set Scan Interval| menu selections. The range for this interval is 0 ms to 65535 ms. Only items that are selected for scanning are scanned within this period.

The bq20z70 EVSW provides a logging function which logs the values that were last scanned by EVSW. To enable this function, select the *Start Logging* button; this causes the *Keep Scanning* button to be selected. When logging is *Stopped*, the keep scanning button is still selected and has to be manually unchecked.

The logging interval are specified under the |Options| menu with the maximum value of 65535 milliseconds. The *Log* interval cannot be smaller than the scan interval because this results in the same value being logged at least twice.



Figure 8. SBS Data Screen

This screen shows the SBS data set along with additional ManufacturersAccess() command information such as individual cell measurements. Additional Flag and Static data can be viewed by selecting the appropriate tab at the bottom of the SBS screen.

Data such as SBS.ManufacturerName( ) is static and does not change. This data is viewed separately using the *Static Data* tab available at the bottom of the screen.

Dragging the splitter bar (line that separates the Flags/Static data from SBS values) changes the height of the Flags/Static Data display. Selecting [View] then [Auto Arrange] returns the splitter bar to its original location.

## 8.2 Setting Programmable bq20z70 and bq29330 Options

The bq20z70 data flash comes configured per the default settings detailed in the bq20z70 data sheet (SLUS686). Ensure that the settings are correctly changed to match the pack and application for the bq20z70/bq29330 solution being evaluated.

**IMPORTANT:** The correct setting of these options is essential to get the best performance.

The settings can be configured using the Data Flash screen.

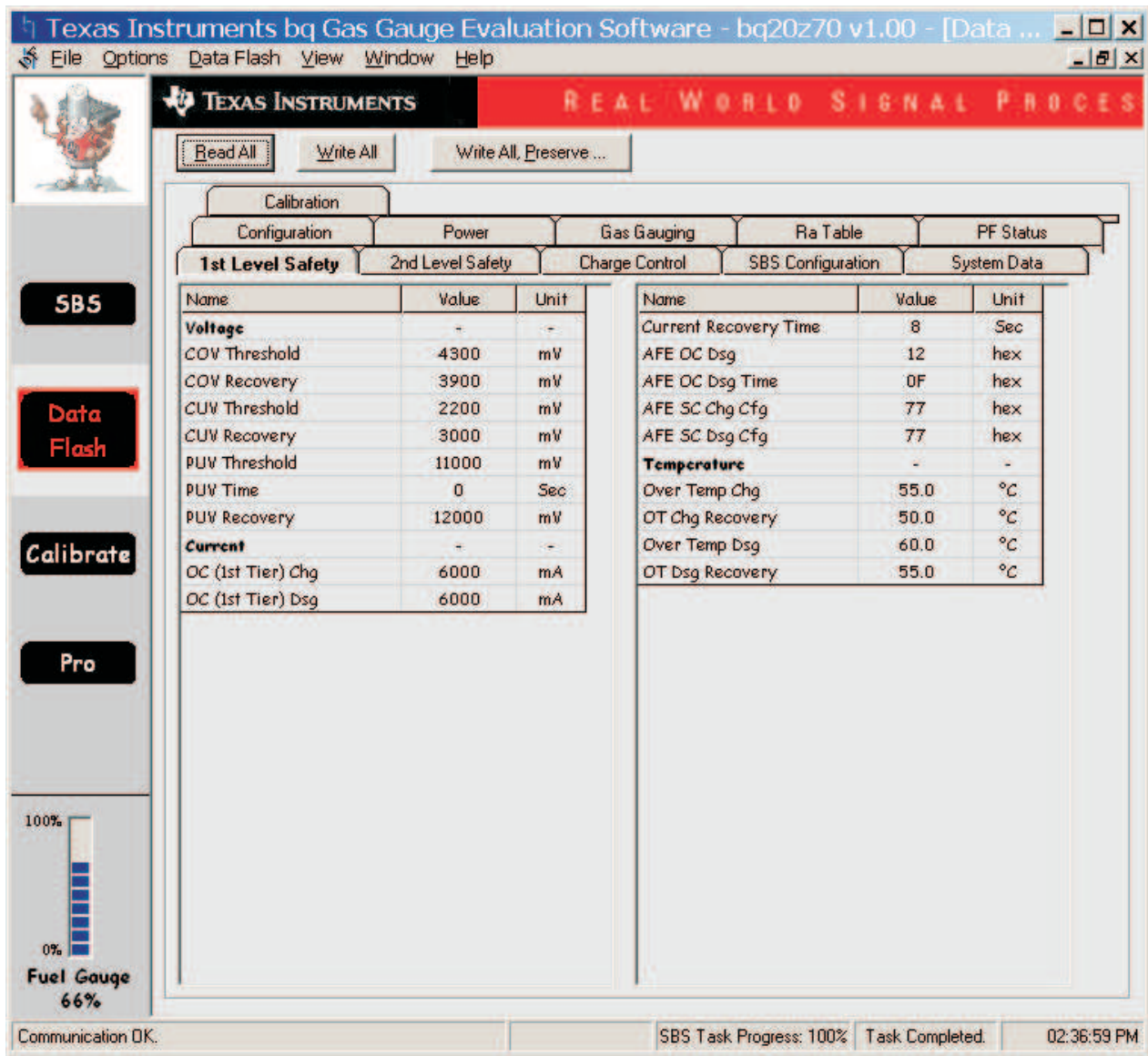

Figure 9. Data Flash Screen, 1st Level Safety Class

To read all the data from the bq20z70 data flash, click on menu option | Data Flash | Read All |.

To write to a data flash location, click on the desired location, enter the data, and press <Enter>, which writes the entire tab of flash data, or select menu option |Data Flash|Write All|. The data flash must be read before any writes are performed to avoid any incorrect data being written to the device.

The | File | Special Export | menu options allows the data flash to be exported, but it configures the exported data flash to a learned state ready for mass production use.

The data flash configuration can be saved to a file by selecting | File | Export |, and entering a file name. A data flash file can also be retrieved in this way, imported, and written to the bq20z70 using the | Write All | button.

The configuration information of the bq29330 and module calibration data is also held in the bq20z70 data flash.

The bq20z70 allows for an automatic data flash export function, similar to the SBS Data logging function. This feature, when selected via | Options | Auto Export |, exports Data Flash to a sequential series of files named as *FilenameNNNNN.gg* where N = a decimal number from 0 to 9.

The AutoExport interval is set under the | Options menu | with a minimum value of 15 seconds. The AutoExport filename is also set under the | Options menu |.

When there is a check next to | AutoExport |, the AutoExport is in progress. The same menu selection is used to turn on/off AutoExport.

If the data flash screen is blank, then the bq20z70 that is being used may not be supported by the bqEVSW version that is being used. An upgrade may be required.

## 9 Calibration Screen

### 9.1 How to Calibrate

Before the bq20z70 is calibrated:

- Connect a load to Pack- and Pack+ that draws approximately 2 A and measures discharge current to use the FETs.
- Connect a current source to Batt- and Pack- to calibrate without using the FETs.
- Measure the pack voltage from Batt+ to Batt- (Total of Cell voltages).
- Measure the temperature of the pack.
- These steps may or may not be required, depending on the type of calibration being performed.

### 9.2 To Calibrate the bq20z70

Select the types of calibration to be performed.

Enter the measured values for the types selected (Except for *CC Offset Calibration*).

If *Voltage Calibration* is selected, then enter the number of cells on the pack.

If *Temperature Calibration* is selected, then select the sensor that is to be calibrated.

If the load is connected between Pack+ and Pack-, then select the *Use FETs* check box.

Press the *Calibrate Part* button.

### 9.3 Board Offset Calibration

This performs the offset calibration for the current offset of the board.

Remove load/external voltage.

Press the *Software Board Offset Calibration* button.

### 9.4 Pack Voltage Calibration

This calibrates the voltage at the AFE Pack pin.

Make sure *Voltage Calibration* has been performed for the pack. If *Voltage Calibration* is not performed, then *Pack Voltage Calibration* calibrates incorrectly.

Remove load/external voltage applied between Pack+ and Pack-.

Press the *Pack Voltage* button to calibrate.

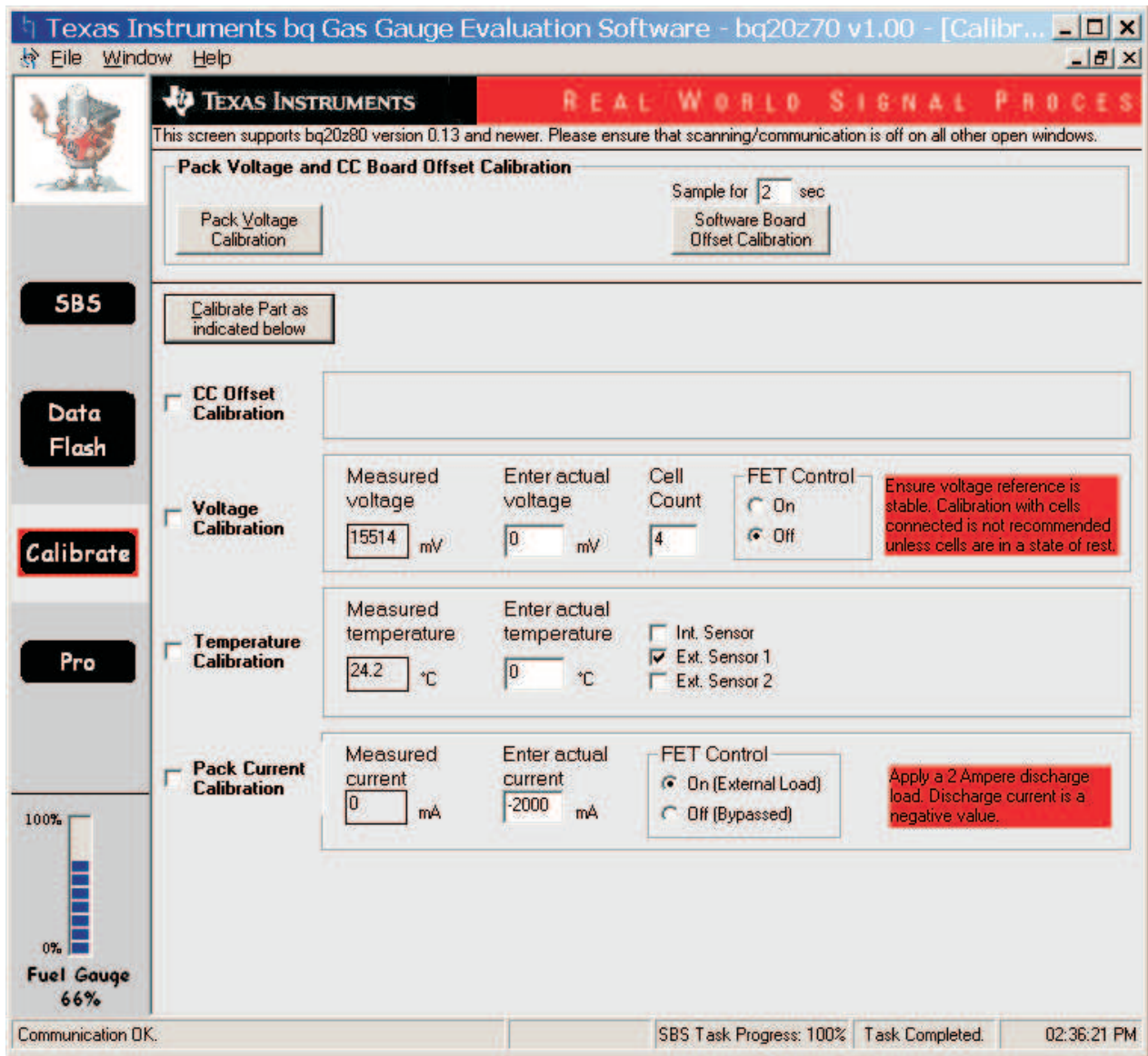

Figure 10. Calibration Screen

## 10 Pro (Advanced) Screen

### 10.1 SMB Communication

The set of read/write operations over SMBus are not specific to any gas gauge. These are provided as general-purpose communication tools.

### 10.2 Hex/Decimal Converter

These two boxes convert between hexadecimal (hex) and decimal as soon as values are typed into the boxes. Invalid values may cause erroneous results.

When scaling converted hex values to a higher number of bytes, follow these rules:

- When unsigned is selected, the left pad contains zeroes.
- When signed is selected, the left pad contains zeroes for a positive number, or the left pad contains *F* for negative numbers.

### 10.3 Programming

Allows for device reprogramming from unencrypted and encrypted files.

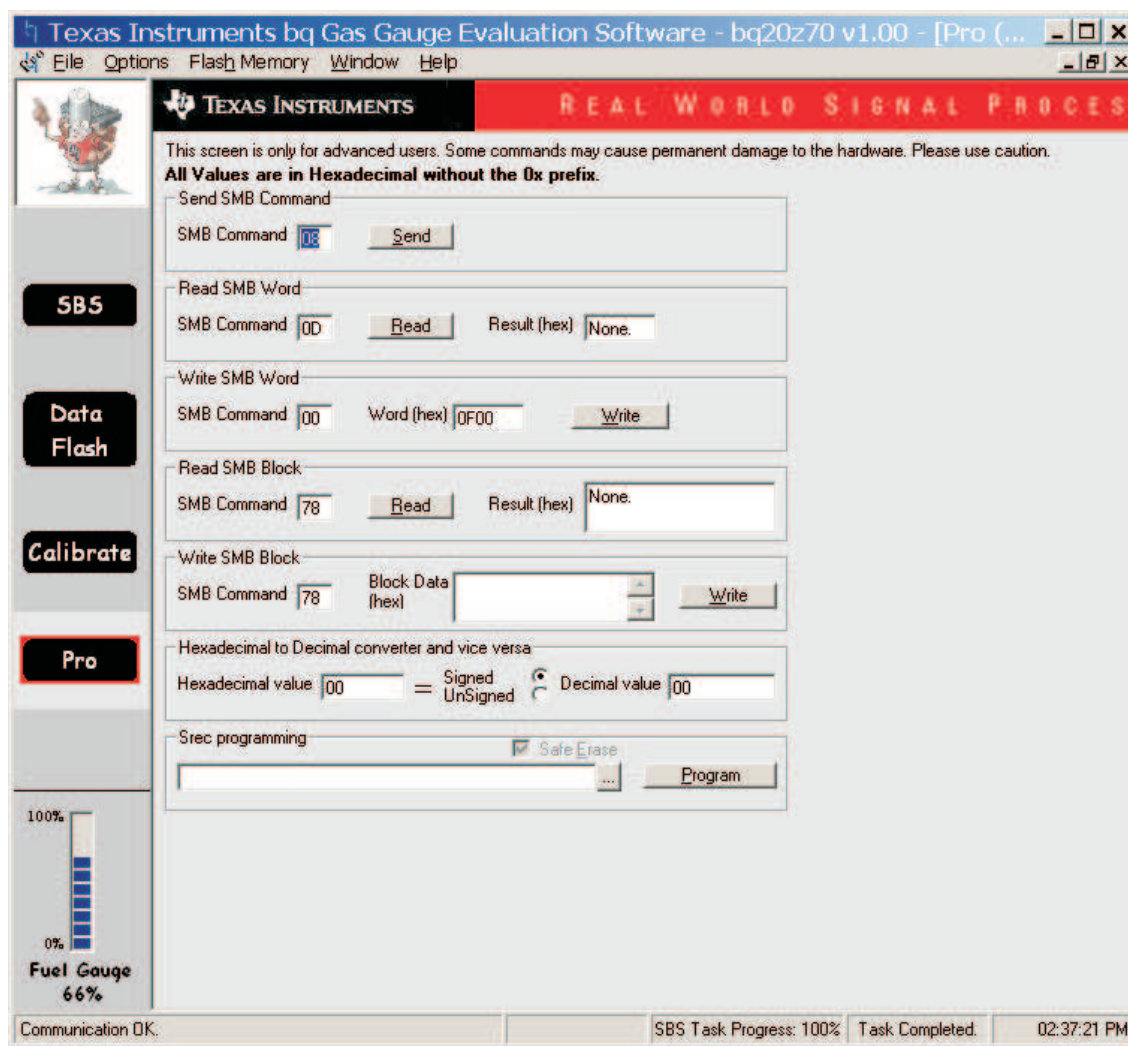

Figure 11. Pro (Advanced) Screen

## 11 Related Documentation from Texas Instruments

To obtain a copy of any of the following TI document, call the Texas Instruments Literature Response Center at (800) 477-8924 or the Product Information Center (PIC) at (972) 644-5580. When ordering, identify this document by its title and literature number. Updated documents can also be obtained through the TI Web site at [www.ti.com](http://www.ti.com).

**Documents:**

bq20z70 Data Sheet

bq20z70 Technical Reference

bq29330 Data Sheet

**Literature Number:**[SLUS686](#)[SLUU250](#)[SLUS673](#)

## IMPORTANT NOTICE

Texas Instruments Incorporated and its subsidiaries (TI) reserve the right to make corrections, enhancements, improvements and other changes to its semiconductor products and services per JESD46, latest issue, and to discontinue any product or service per JESD48, latest issue. Buyers should obtain the latest relevant information before placing orders and should verify that such information is current and complete. All semiconductor products (also referred to herein as "components") are sold subject to TI's terms and conditions of sale supplied at the time of order acknowledgment.

TI warrants performance of its components to the specifications applicable at the time of sale, in accordance with the warranty in TI's terms and conditions of sale of semiconductor products. Testing and other quality control techniques are used to the extent TI deems necessary to support this warranty. Except where mandated by applicable law, testing of all parameters of each component is not necessarily performed.

TI assumes no liability for applications assistance or the design of Buyers' products. Buyers are responsible for their products and applications using TI components. To minimize the risks associated with Buyers' products and applications, Buyers should provide adequate design and operating safeguards.

TI does not warrant or represent that any license, either express or implied, is granted under any patent right, copyright, mask work right, or other intellectual property right relating to any combination, machine, or process in which TI components or services are used. Information published by TI regarding third-party products or services does not constitute a license to use such products or services or a warranty or endorsement thereof. Use of such information may require a license from a third party under the patents or other intellectual property of the third party, or a license from TI under the patents or other intellectual property of TI.

Reproduction of significant portions of TI information in TI data books or data sheets is permissible only if reproduction is without alteration and is accompanied by all associated warranties, conditions, limitations, and notices. TI is not responsible or liable for such altered documentation. Information of third parties may be subject to additional restrictions.

Resale of TI components or services with statements different from or beyond the parameters stated by TI for that component or service voids all express and any implied warranties for the associated TI component or service and is an unfair and deceptive business practice. TI is not responsible or liable for any such statements.

Buyer acknowledges and agrees that it is solely responsible for compliance with all legal, regulatory and safety-related requirements concerning its products, and any use of TI components in its applications, notwithstanding any applications-related information or support that may be provided by TI. Buyer represents and agrees that it has all the necessary expertise to create and implement safeguards which anticipate dangerous consequences of failures, monitor failures and their consequences, lessen the likelihood of failures that might cause harm and take appropriate remedial actions. Buyer will fully indemnify TI and its representatives against any damages arising out of the use of any TI components in safety-critical applications.

In some cases, TI components may be promoted specifically to facilitate safety-related applications. With such components, TI's goal is to help enable customers to design and create their own end-product solutions that meet applicable functional safety standards and requirements. Nonetheless, such components are subject to these terms.

No TI components are authorized for use in FDA Class III (or similar life-critical medical equipment) unless authorized officers of the parties have executed a special agreement specifically governing such use.

Only those TI components which TI has specifically designated as military grade or "enhanced plastic" are designed and intended for use in military/aerospace applications or environments. Buyer acknowledges and agrees that any military or aerospace use of TI components which have **not** been so designated is solely at the Buyer's risk, and that Buyer is solely responsible for compliance with all legal and regulatory requirements in connection with such use.

TI has specifically designated certain components as meeting ISO/TS16949 requirements, mainly for automotive use. In any case of use of non-designated products, TI will not be responsible for any failure to meet ISO/TS16949.

### Products

Audio	<a href="http://www.ti.com/audio">www.ti.com/audio</a>
Amplifiers	<a href="http://amplifier.ti.com">amplifier.ti.com</a>
Data Converters	<a href="http://dataconverter.ti.com">dataconverter.ti.com</a>
DLP® Products	<a href="http://www.dlp.com">www.dlp.com</a>
DSP	<a href="http://dsp.ti.com">dsp.ti.com</a>
Clocks and Timers	<a href="http://www.ti.com/clocks">www.ti.com/clocks</a>
Interface	<a href="http://interface.ti.com">interface.ti.com</a>
Logic	<a href="http://logic.ti.com">logic.ti.com</a>
Power Mgmt	<a href="http://power.ti.com">power.ti.com</a>
Microcontrollers	<a href="http://microcontroller.ti.com">microcontroller.ti.com</a>
RFID	<a href="http://www.ti-rfid.com">www.ti-rfid.com</a>
OMAP Applications Processors	<a href="http://www.ti.com/omap">www.ti.com/omap</a>
Wireless Connectivity	<a href="http://www.ti.com/wirelessconnectivity">www.ti.com/wirelessconnectivity</a>

### Applications

Automotive and Transportation	<a href="http://www.ti.com/automotive">www.ti.com/automotive</a>
Communications and Telecom	<a href="http://www.ti.com/communications">www.ti.com/communications</a>
Computers and Peripherals	<a href="http://www.ti.com/computers">www.ti.com/computers</a>
Consumer Electronics	<a href="http://www.ti.com/consumer-apps">www.ti.com/consumer-apps</a>
Energy and Lighting	<a href="http://www.ti.com/energy">www.ti.com/energy</a>
Industrial	<a href="http://www.ti.com/industrial">www.ti.com/industrial</a>
Medical	<a href="http://www.ti.com/medical">www.ti.com/medical</a>
Security	<a href="http://www.ti.com/security">www.ti.com/security</a>
Space, Avionics and Defense	<a href="http://www.ti.com/space-avionics-defense">www.ti.com/space-avionics-defense</a>
Video and Imaging	<a href="http://www.ti.com/video">www.ti.com/video</a>

### TI E2E Community

[e2e.ti.com](http://e2e.ti.com)

## Looking for pricing, stock, or lifecycle information?

Click below to explore more details on WIN SOURCE:

 [View BQ20Z70EVM-001](#) on WIN SOURCE

 [Texas Instruments](#) Information

## Optimize Your Supply Chain with WIN SOURCE Solutions

-  Global Sourcing Solution
-  Obsolete Management
-  Cost Control Management
-  Shortage Management
-  Alternative Solution
-  Excess Inventory Management