

○ Electrical Characteristics

(Unless otherwise specified, Ta = 25°C; VCC = 5 V; Vbias = 2.5 V; Vmode = 5 V)

Parameter	Symbol	Limit			Unit	Conditions
		Min.	Typ.	Max.		
[Overall]						
Power supply voltage range	Vcc	3	5	28	V	
Current consumption (STBY)	ISC	-	0	1.0	μA	VST=0V
Current consumption (Normal)	Icc	-	60	100	μA	ΔVin=0V
Voltage gain (100x)	Gv1	98	100	102	mV/mV	※Ta=-30~85°C
Voltage gain (50x)	Gv2	49	50	51	mV/mV	※Ta=-30~85°C
[NEG, POS pins]						
Input conversion offset voltage	Voff	-0.5	0	0.5	mV	ΔVin=0V
In-phase input voltage range	Vicm	1.8	-	28	V	
Differential input voltage range	Vidf	-200	-	200	mV	
Input bias current	Ib1	-	1.2	1.6	μA	ΔVin=0V, POS, Neg=25V
Input impedance	Zi	100	-	-	kΩ	
[BIAS pin]						
BIAS pin set voltage range	Vbias	1.2	-	Vcc-1.2	V	
BIAS pin sinking current	Ibias	-	0	0.1	uA	Vbias=2.5V
[ST pin]						
ST pin sinking current	IST	-	1.5	10	uA	VST=5V
ST pin threshold	VST	0.3	1.0	2.7	V	
[MODE pin] (BD3180FV only)						
MODE pin sinking current	Imode	-	0	1.0	uA	Vmode=5V
MODE pin set voltage range 1 (100x)	Vmode1	2.2	-	VCC	V	
MODE pin set voltage range 2 (50x)	Vmode2	0	-	1.0	V	
[OUT pin]						
High output voltage	VoutH	VCC-0.1	Vcc	-	V	
Low output voltage	VoutL	-	0	0.1	V	VCC=3V, Vbias=1.2V
Output source current	Isrc	0.5	1.0	-	mA	Vout=Vcc-0.1V
Output sinking current	Isink	-0.5	-1.0	-	mA	Vout=0.1V

○ PACKAGE

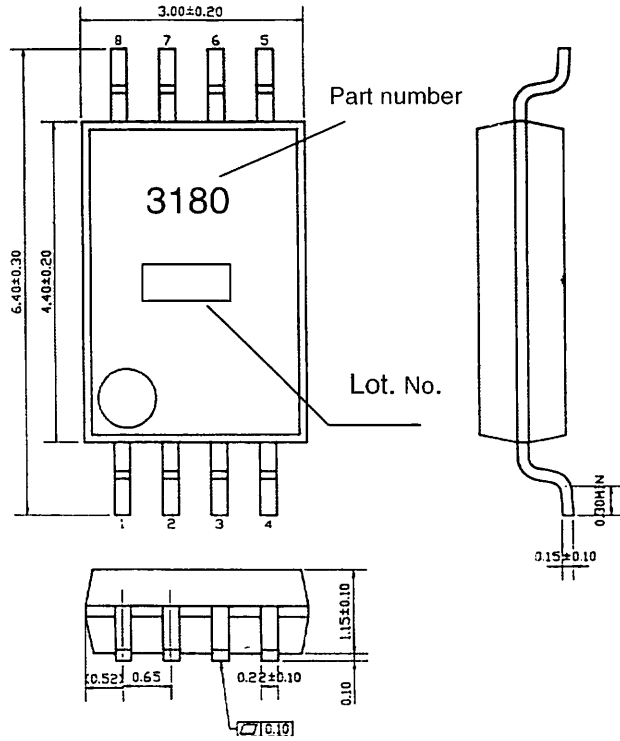

SSOP-B8 (UNIT : mm)

○ Block Diagram

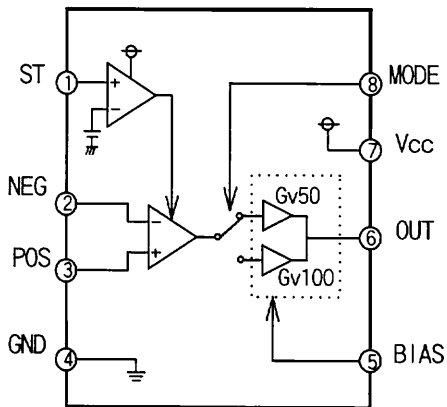

○ Pin No.

Pin No.	Pin Name	Function
1	ST	Standby pin
2	NEG	Inverted input pin
3	POS	Non-inverted input pin
4	GND	Ground pin
5	BIAS	Reference voltage input pin
6	OUT	Output pin
7	Vcc	Power supply pin
8	MODE	Gain selection pin

○ Operation Notes

1. Absolute maximum ratings

Use of the IC in excess of absolute maximum ratings such as the applied voltage or operating temperature range may result in IC deterioration or damage. Assumptions should not be made regarding the state of the IC (short mode or open mode) when such damage is suffered. A physical safety measure such as a fuse should be implemented when use of the IC in a special mode where the absolute maximum ratings may be exceeded is anticipated.

2. GND potential

Ensure a minimum GND pin potential in all operating conditions. In addition, ensure that no pins other than the GND pin carry a voltage less than or equal to the GND pin, including during actual transient phenomena.

3. Setting of heat

Use a thermal design that allows for a sufficient margin in light of the power dissipation (Pd) in actual operating conditions.

4. Protection circuit

The IC does not incorporate built-in malfunction protection such as overcurrent protection, short detection, or thermal shutdown circuitry. For this reason, the IC may be damaged if it is shorted or subjected to a load that exceeds the package power. The design of peripheral application circuits should reflect these potential risks.

5. Pin short and mistake fitting

Use caution when orienting and positioning the IC for mounting on PCBs. Improper mounting may result in damage to the IC. Shorts between output pins or between output pins and the power supply and GND pin caused by the presence of a foreign object may result in damage to the IC.

6. Mutual impedance

Power supply and ground wiring should reflect consideration of the need to lower mutual impedance and minimize ripple as much as possible (by making wiring as short and thick as possible or rejecting ripple by incorporating inductance and capacitance).

Notes

- No technical content pages of this document may be reproduced in any form or transmitted by any means without prior permission of ROHM CO.,LTD.
- The contents described herein are subject to change without notice. The specifications for the product described in this document are for reference only. Upon actual use, therefore, please request that specifications to be separately delivered.
- Application circuit diagrams and circuit constants contained herein are shown as examples of standard use and operation. Please pay careful attention to the peripheral conditions when designing circuits and deciding upon circuit constants in the set.
- Any data, including, but not limited to application circuit diagrams information, described herein are intended only as illustrations of such devices and not as the specifications for such devices. ROHM CO.,LTD. disclaims any warranty that any use of such devices shall be free from infringement of any third party's intellectual property rights or other proprietary rights, and further, assumes no liability of whatsoever nature in the event of any such infringement, or arising from or connected with or related to the use of such devices.
- Upon the sale of any such devices, other than for buyer's right to use such devices itself, resell or otherwise dispose of the same, no express or implied right or license to practice or commercially exploit any intellectual property rights or other proprietary rights owned or controlled by
- ROHM CO., LTD. is granted to any such buyer.
- Products listed in this document are no antiradiation design.

The products listed in this document are designed to be used with ordinary electronic equipment or devices (such as audio visual equipment, office-automation equipment, communications devices, electrical appliances and electronic toys).

Should you intend to use these products with equipment or devices which require an extremely high level of reliability and the malfunction of which would directly endanger human life (such as medical instruments, transportation equipment, aerospace machinery, nuclear-reactor controllers, fuel controllers and other safety devices), please be sure to consult with our sales representative in advance.

About Export Control Order in Japan

Products described herein are the objects of controlled goods in Annex 1 (Item 16) of Export Trade Control Order in Japan.

In case of export from Japan, please confirm if it applies to "objective" criteria or an "informed" (by MITI clause) on the basis of "catch all controls for Non-Proliferation of Weapons of Mass Destruction.

Thank you for your accessing to ROHM product informations.
More detail product informations and catalogs are available,
please contact your nearest sales office.

Please contact our sales offices for details ;

U.S.A / San Diego	TEL : +1(858)625-3630	FAX : +1(858)625-3670
Atlanta	TEL : +1(770)754-5972	FAX : +1(770)754-0691
Dallas	TEL : +1(972)312-8818	FAX : +1(972)312-0330
Germany / Dusseldorf	TEL : +49(2154)9210	FAX : +49(2154)921400
United Kingdom / London	TEL : +44(1)908-282-666	FAX : +44(1)908-282-528
France / Paris	TEL : +33(0)1 56 97 30 60	FAX : +33(0) 1 56 97 30 80
China / Hong Kong	TEL : +852(2)740-6262	FAX : +852(2)375-8971
Shanghai	TEL : +86(21)6279-2727	FAX : +86(21)6247-2066
Dilian	TEL : +86(411)8230-8549	FAX : +86(411)8230-8537
Beijing	TEL : +86(10)8525-2483	FAX : +86(10)8525-2489
Taiwan / Taipei	TEL : +866(2)2500-6956	FAX : +866(2)2503-2869
Korea / Seoul	TEL : +82(2)8182-700	FAX : +82(2)8182-715
Singapore	TEL : +65-6332-2322	FAX : +65-6332-5662
Malaysia / Kuala Lumpur	TEL : +60(3)7958-8355	FAX : +60(3)7958-8377
Philippines / Manila	TEL : +63(2)807-6872	FAX : +63(2)809-1422
Thailand / Bangkok	TEL : +66(2)254-4890	FAX : +66(2)256-6334

Japan /
(Internal Sales)

Tokyo	2-1-1, Yaesu, Chuo-ku, Tokyo 104-0082	TEL : +81(3)5203-0321	FAX : +81(3)5203-0300
Yokohama	2-4-8, Shin Yokohama, Kohoku-ku, Yokohama, Kanagawa 222-8575	TEL : +81(45)476-2131	FAX : +81(45)476-2128
Nagoya	Dainagayo Building 9F 3-28-12, Meieki, Nakamura-ku, Nagoya, Aichi 450-0002	TEL : +81(52)581-8521	FAX : +81(52)561-2173
Kyoto	579-32 Higashi Shiokouji-cho, Karasuma Nishi-iru, Shiokoujidori, Shimogyo-ku, Kyoto 600-8216	TEL : +81(75)311-2121	FAX : +81(75)314-6559

(Contact address for overseas customers in Japan)

Yokohama	TEL : +81(45)476-9270	FAX : +81(045)476-9271
----------	-----------------------	------------------------

Looking for pricing, stock, or lifecycle information?

Click below to explore more details on WIN SOURCE:

- [View BD3180FV-E2 on WIN SOURCE](#)
- [Rohm Semiconductor Information](#)

Optimize Your Supply Chain with WIN SOURCE Solutions

- ✓ Global Sourcing Solution
- ✓ Obsolete Management
- ✓ Cost Control Management
- ✓ Shortage Management
- ✓ Alternative Solution
- ✓ Excess Inventory Management