



# THE DATASHEET OF BD65D00MUV-E2



# 4-Channel White LED Driver with Integrated FET for up to 40 LEDs

## BD65D00MUV

### General Description

This IC is white LED driver IC with PWM step-up DC/DC converter that can boost max 41V and current driver that can drive max 100mA. The wide and precision brightness can be controlled by external PWM pulse. This IC has very accurate current drivers, and it has few current errors between each strings. So, it will be helpful to reduce brightness spots on the LCD panel. Small package is suited for saving space. It can respond to the application according to the application to be able to switch to external/internal NchFET boosting.

- PWM dimming(100Hz - 25kHz) Analog Brightness Control

### Key Specifications

- Operating power supply voltage range: 6V to 27V
- LED maximum current: 100mA/ch
- Quiescent Current: 1.6μA (typ.)
- Operating temperature range: -40 to +85

### Package

W(typ.) x D(typ.) x H(Max.)



**VQFN028V5050**  
5.00mm x 5.00mm x 1.00mm

Figure 1.

### Features

- High efficiency PWM step-up DC/DC converter (fsw=typ 1.25MHz, 0.60MHz to 1.6MHz)
- High accuracy & good matching current drivers 4ch (MAX100mA/ch)
- Integrated 50V power Nch MOSFET
- Soft Start function
- Drive up to 10 LEDs in series, 4 strings in parallel
- Various safety functions
  - Over-voltage protection
  - External SBD open detect / Output Short protection
  - Over current limit
  - CH Terminal open / GND short protect
  - CH over voltage protect / LED short protect
  - Thermal shutdown
  - UVLO
  - ISET short protection

### Applications

All LCD equipments, Backlight of Notebook PC, Amusement, net book, monitor, TV, Portable DVD player, light source etc.

### Typical Application Circuit (4 parallel)

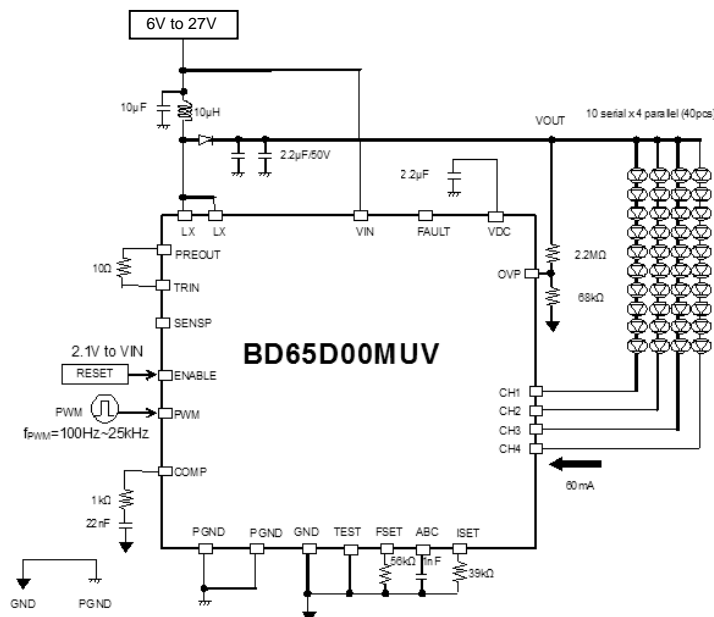

Figure 2. Typical Application Circuit

Product structure : Silicon monolithic integrated circuit This product is not designed protection against radioactive rays

**Absolute Maximum Ratings** (Ta=25 )

Parameter	Symbol	Ratings	Unit	Conditions
Terminal voltage 1	VMAX1	7	V	VDC, ISET, ABC, COMP, FSET, TEST, FAULT, PREOUT, TRIN, SENSP
Terminal voltage 2	VMAX2	45	V	CH1 to CH4, LX, OVP
Terminal voltage 3	VMAX3	30.5	V	VIN, ENABLE
Terminal voltage 4	VMAX4	15	V	PWM
Power dissipation 1	Pd1	380 <sup>*1</sup>	mW	
Power dissipation 2	Pd2	880 <sup>*2</sup>	mW	
Power dissipation 3	Pd3	3264 <sup>*3</sup>	mW	
Operating temperature range	Topr	-40 to +85		
Storage temperature range	Tstg	-55 to +150		

\*1 Reduced 3.0mW/ With Ta>25 when not mounted on a heat radiation Board.

\*2 1 layer (ROHM Standard board) has been mounted. Copper foil area 0mm<sup>2</sup>, When it's used by more than Ta=25, it's reduced by 7.0mW/

\*3 4 layer (JEDEC Compliant board) has been mounted. Copper foil area 1.4layer 20.2mm<sup>2</sup>, Copper foil area 2 to 3layers 5505mm<sup>2</sup>, When it's used by more than Ta=25, it's reduced by 26.1mW/

\*Power dissipation is calculated by formula : (Storage temperature max - 25 )/ ja (ex. Pd1=3.0mW/ )

**Recommended Operating Ratings** (Ta=-40 to +85 )

Parameter	Symbol	Limits			Unit	Conditions
		Min.	Typ.	Max.		
Power supply voltage	VINL	6.0	12.0	27.0	V	Coil power supply
	VIN	4.5	5	27.0	V	IC power supply

**Electrical Characteristics**

(Unless otherwise specified, VIN=12V, Ta = +25 )

Parameter	Symbol	Limits			Unit	Conditions
		Min.	Typ.	Max.		
<b>[General]</b>						
Quiescent Current	Iq	-	1.6	4.4	μA	ENABLE=0V
Current Consumption	Idd	-	3.6	5.4	mA	OVP=0V,ISET=39kΩ
Max. Output Voltage	MOV	-	-	41	V	
Under Voltage Lock Out	UVLO	-	3.7	4.1	V	VIN falling edge
<b>[ENABLE Terminal]</b>						
Low Level Input Voltage	EnL	0.0	-	0.8	V	
High Level Input Voltage 1	EnH	2.0	-	VIN	V	
ENABLE Pull down resistor	EnR	100	300	500	kΩ	ENABLE =3V
Output Current	ENIout	-	0	2	μA	ENABLE=0V
<b>[PWM Terminal]</b>						
Low Level Input Voltage	PWML	0.0	-	0.8	V	
High Level Input Voltage 2	PWMH	1.3	-	14.5	V	
PWM Pull down resistor	PWMR	100	300	500	kΩ	PWM=3V
Output Current	PWMIout	-	0	2	μA	PWM=0V
<b>[FAULT]</b>						
Nch RON	FFCR	-	-	3	kΩ	ENABLE=PWM=3V, OVP=2V
<b>[Regulator]</b>						
VDC Voltage	VREG	4.2	5.0	6.0	V	No load, VIN > 6V

**Electrical Characteristics - continued**

(Unless otherwise specified, VIN=12V, Ta = +25 )

Parameter	Symbol	Limits			Unit	Conditions
		Min.	Typ.	Max.		
<b>[Switching Regulator]</b>						
LED Control voltage	VLED	0.64	0.80	0.96	V	
Switching frequency accuracy	Fsw	1.00	1.25	1.50	MHz	FSET=56kΩ
Duty cycle limit	Duty	91.0	95.0	99.0	%	CH1-4=0.3V, FSET=56kΩ
LX Nch FET RON	RON	-	0.3	0.5	Ω	ILX=80mA
<b>[Protection]</b>						
Over Current Limit	Ocp	1.5	2.5	-	A	*1
Over voltage limit Input	OVP	1.16	1.20	1.24	V	Detect voltage of OVP pin
Output Short Protect	OVPfault	0.02	0.05	0.08	V	Detect voltage of OVP pin
OVP leak current	OVIL	-	0.1	1.0	μA	
CH Terminal Over Voltage Protect accuracy	VSC	-15	0	+15	%	VSC=8V
<b>[Current driver]</b>						
LED maximum current	ILMAX	-	-	100	mA	This is current driver's characteristics. This IC may not output current according to application.
LED current accuracy	ILACCU	-	-	±5.0	%	ILED=60mA (39kΩ)
LED current matching	ILMAT	-	-	3.0	%	(Max LED current – Min LED current)/ Ideal current (60mA) ILED=60mA
LED current limiter	ILOCP	-	0	0.1	mA	Current limit value at ISET Resistance 1kΩ setting
ISET voltage	Iset	-	0.733	-	V	
LED current accuracy2	ILACCU2	-	±3.0	-	%	ILED=60mA, ABC=0.733V

\*1 This parameter is tested with DC measurement.

**Block Diagram**

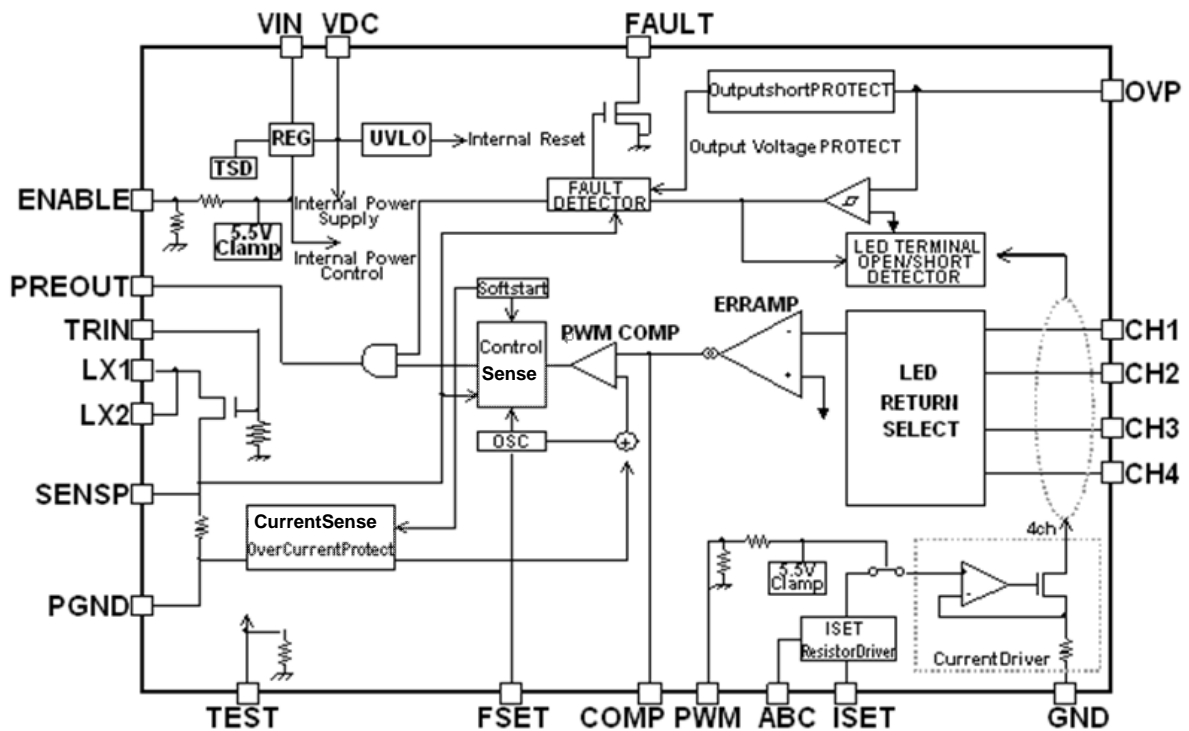

Pin number 22pin  
Figure 3. Block Diagram

Pin Descriptions

PIN No.	PIN Name	IO	Function	Terminal diagram
1	VDC	Out	Regulator output / Internal power-supply	C
2	TEST	In	TEST signal (Pull down 100kΩ within IC)	E
3	FSET	In	Resistor connection for frequency setting	A
4	ABC	In	PIN for Analog Brightness Control	C
5	GND	-	GND for Switching Regulator	B
6	COMP	Out	ERRAMP output	A
7	ISET	In	Resistor connection for LED current setting	A
8	CH4	In	Current driver sink for CH4	C
9	NC	-	-	-
10	CH3	In	Current driver sink for CH3	C
11	NC	-	-	-
12	CH2	In	Current driver sink for CH2	C
13	NC	-	-	-
14	CH1	In	Current driver sink for CH1	C
15	NC	-	-	-
16	GND	-	GND for Current Driver	B
17	FAULT	Out	Fault signal	C
18	PREOUT	Out	Signal output pin for internal switching Tr	A
19	TRIN	In	Gate terminal for switching Tr	A
20	SENSP	In	Source terminal for external switching Tr	A
21	PGND	-	PGND for switching Tr	D
22	LX	Out	Switching Tr drive terminal	F
23	LX			
24	NC	-	-	-
25	OVP	In	Detect input for SBD open and OVP	C
26	PWM	In	Input pin for current driver power ON/OFF	E
27	ENABLE	In	Pin for power ON/OFF or Power control	E
28	VIN	In	Battery input	G
-	Thermal PAD	-	Heat radiation PAD of back side Connect to GND	

Pin ESD Type

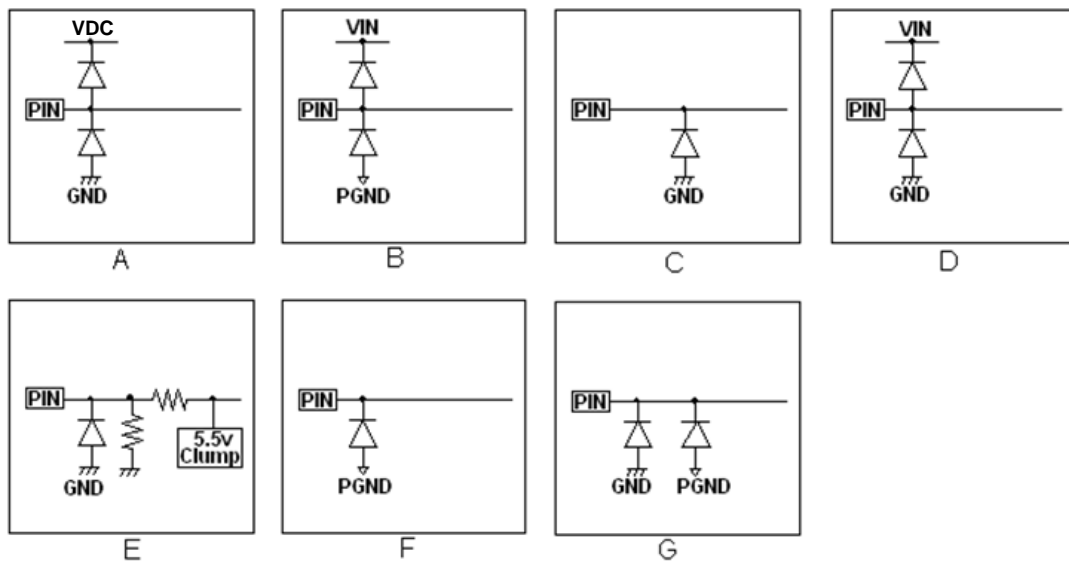

Figure 4. Pin ESD Type

Typical Performance Curves

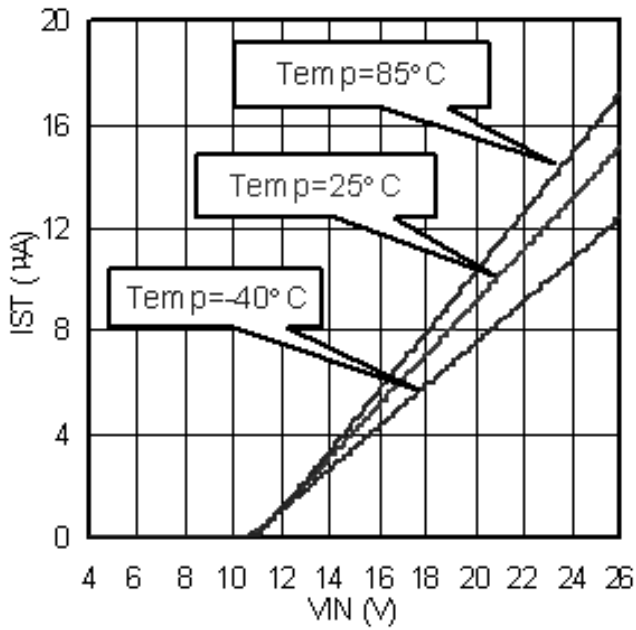

Figure 5. Quiescent Current

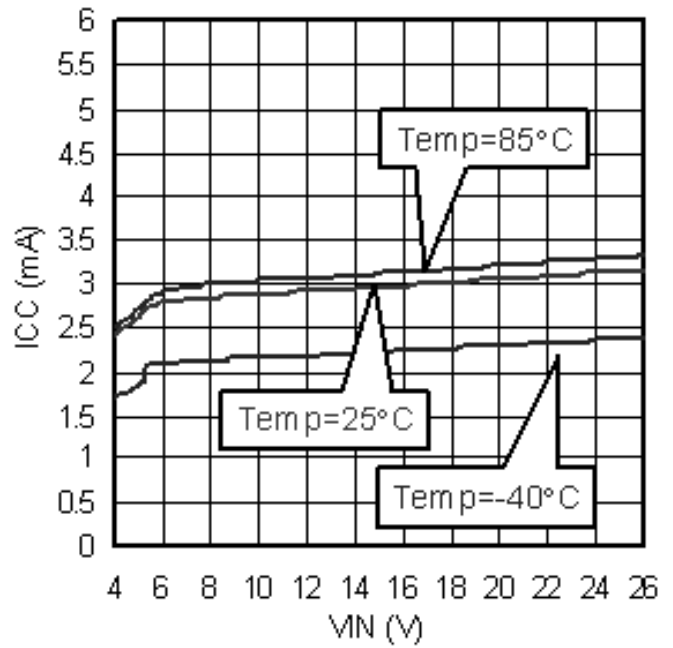

Figure 6. Current Consumption

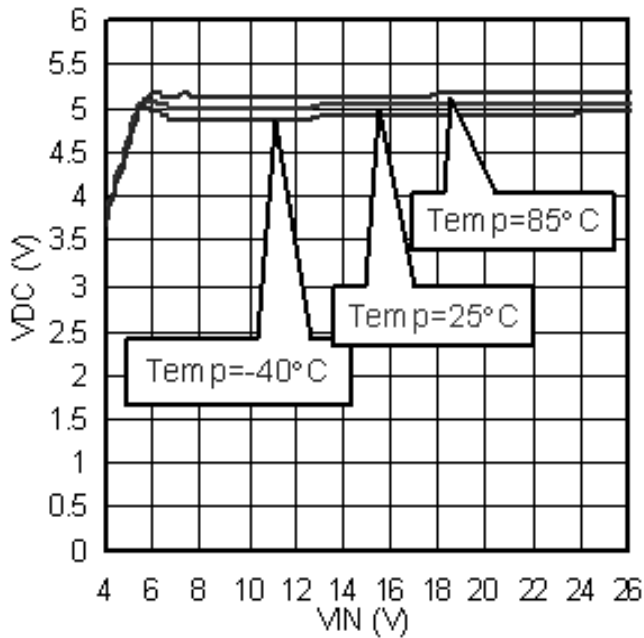

Figure 7. VDC Voltage

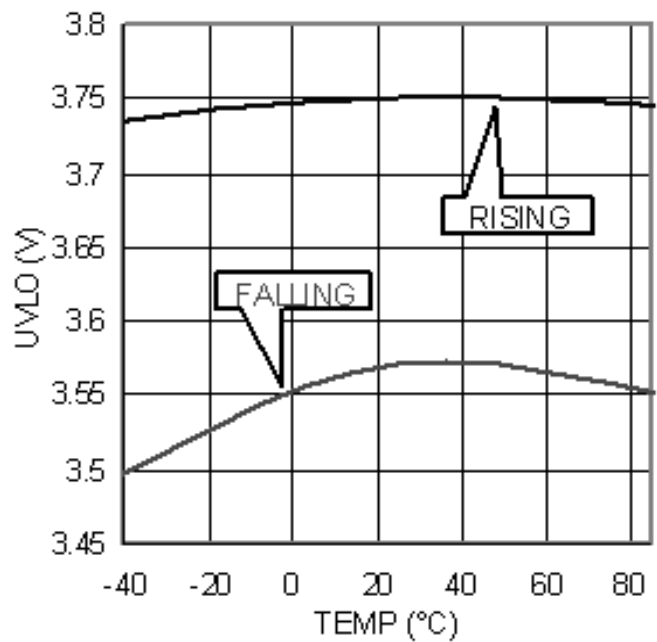

Figure 8. Under Voltage Lock Out

Typical Performance Curves

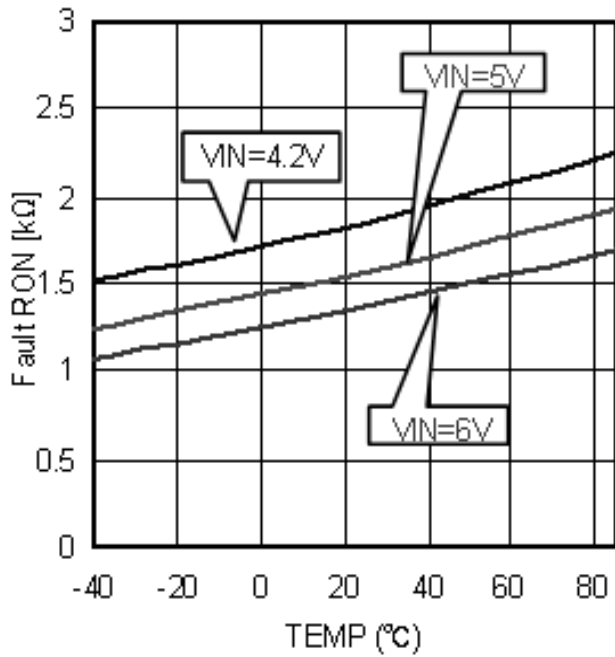

Figure 9. Fault RON

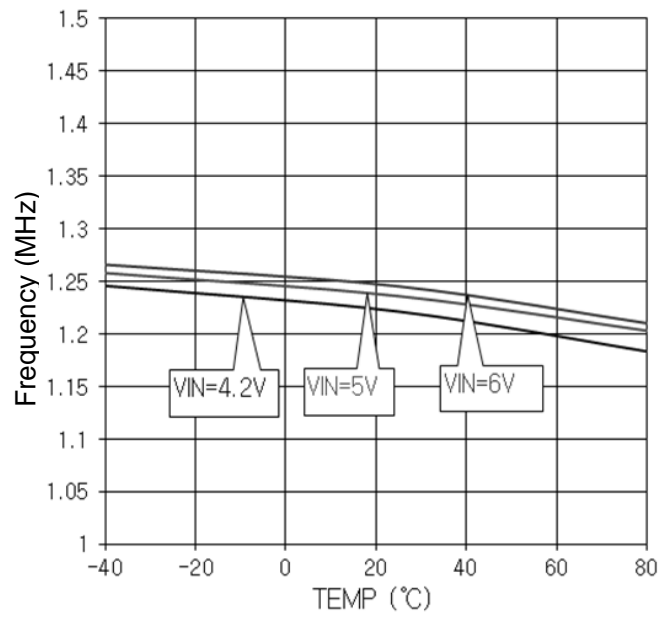

Figure 10. Switching Frequency

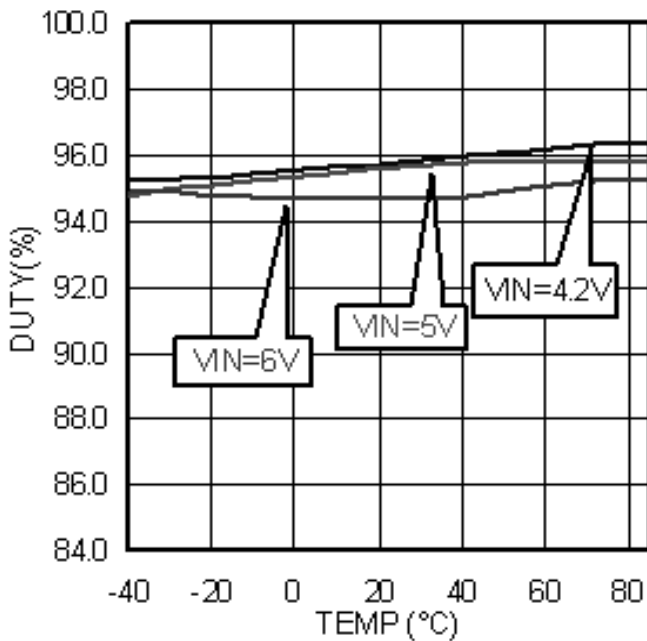

Figure 11. Max Duty

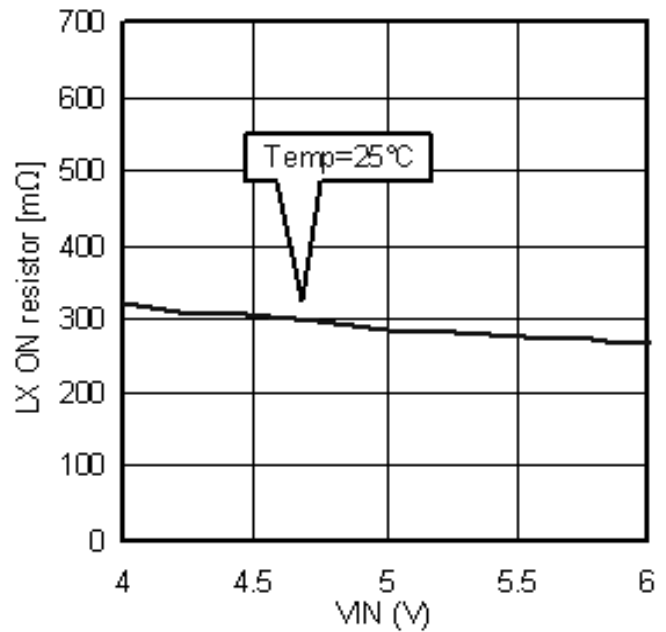

Figure 12. LX Nch RON

Typical Performance Curves - continued

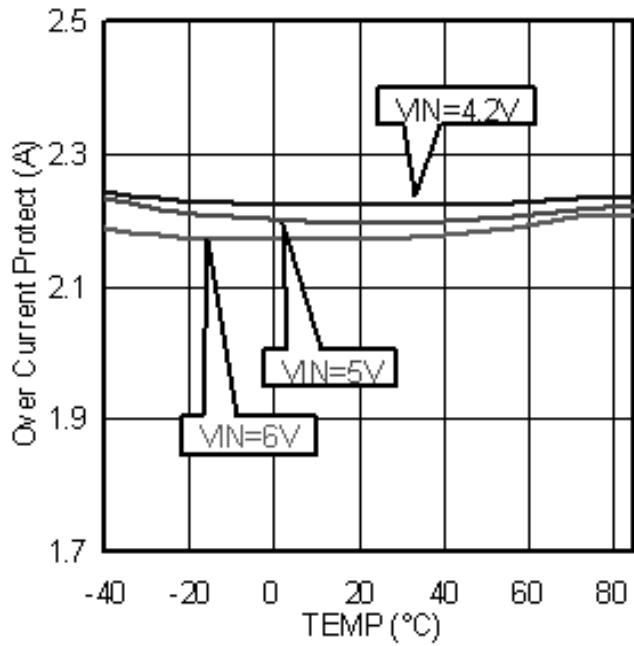

Figure 13. Over Current Limit

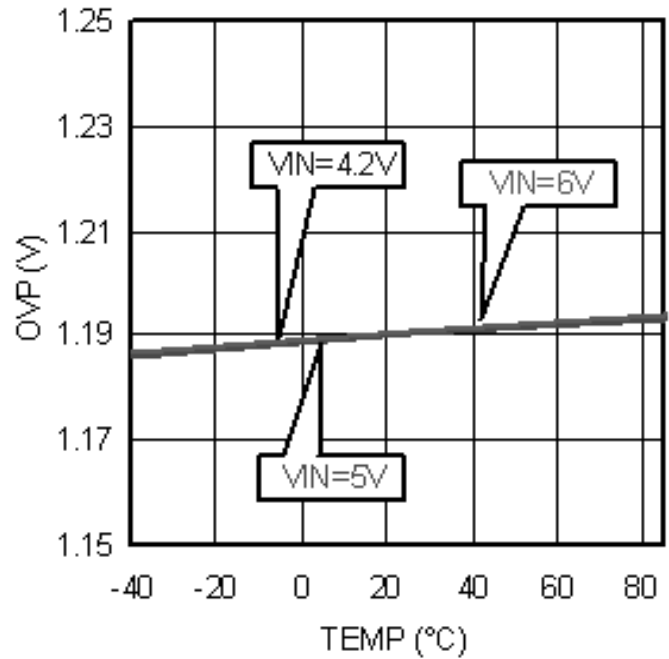

Figure 14. Over Voltage Protect

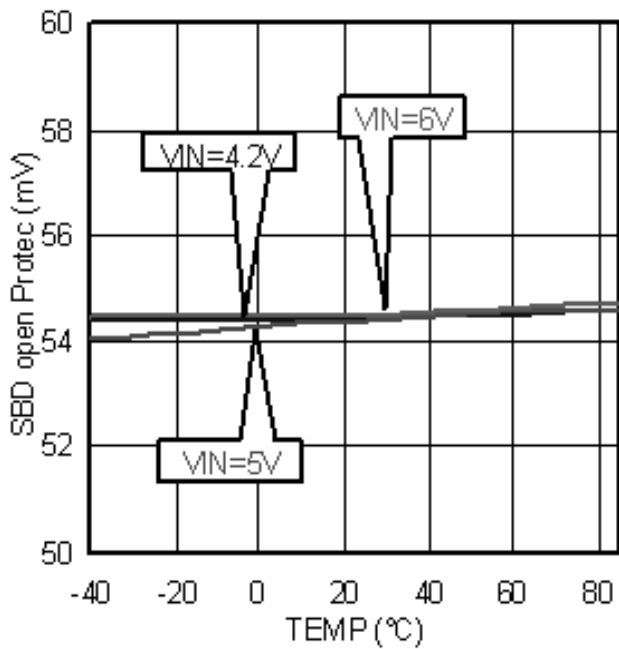

Figure 15. Output Short Protect

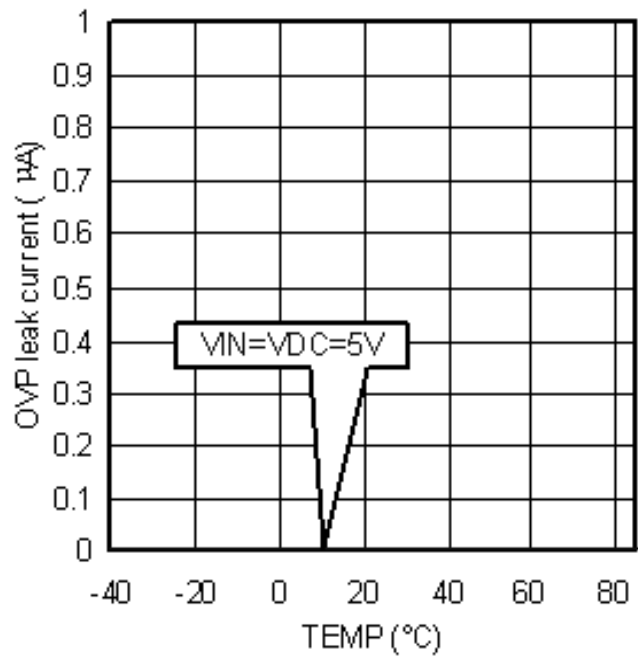

Figure 16. OVP Leak Current

Typical Performance Curves - continued

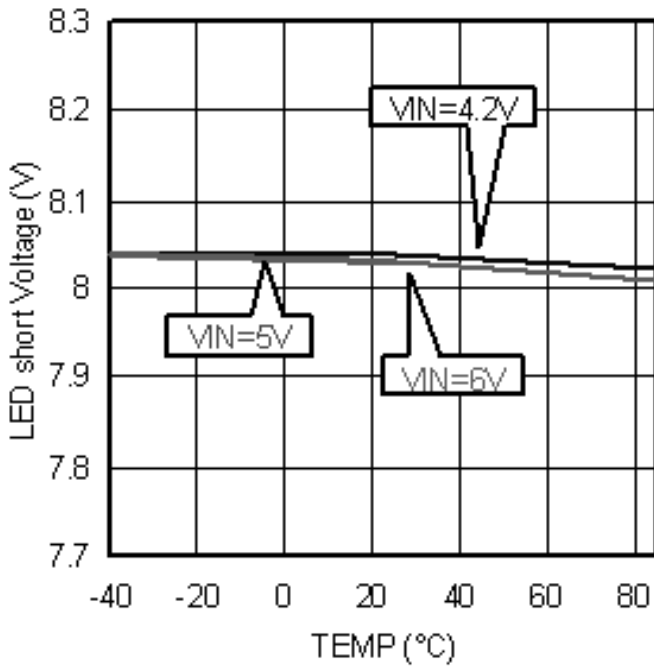

Figure 17. CH Terminal OVP

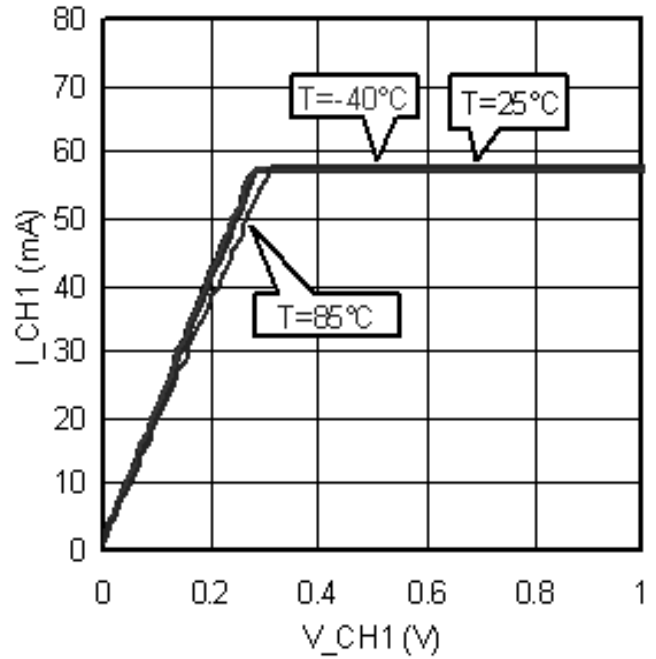

Figure 18. LED Current vs. CH Voltage

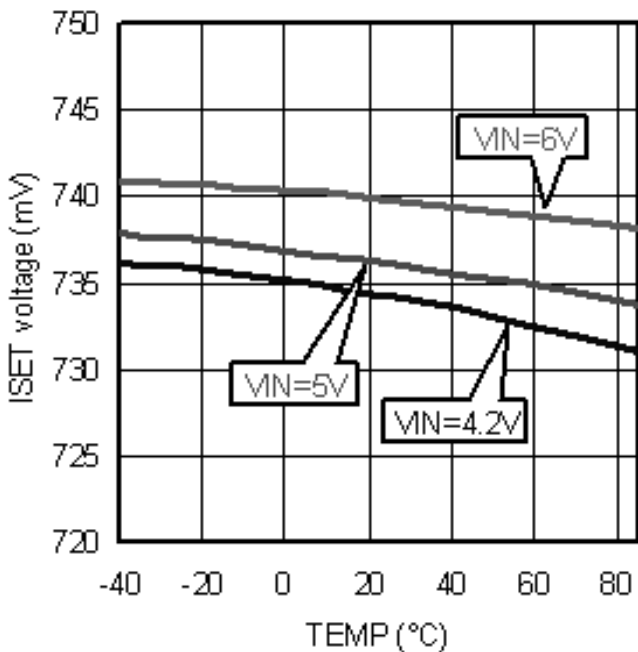

Figure 19. ISET Voltage

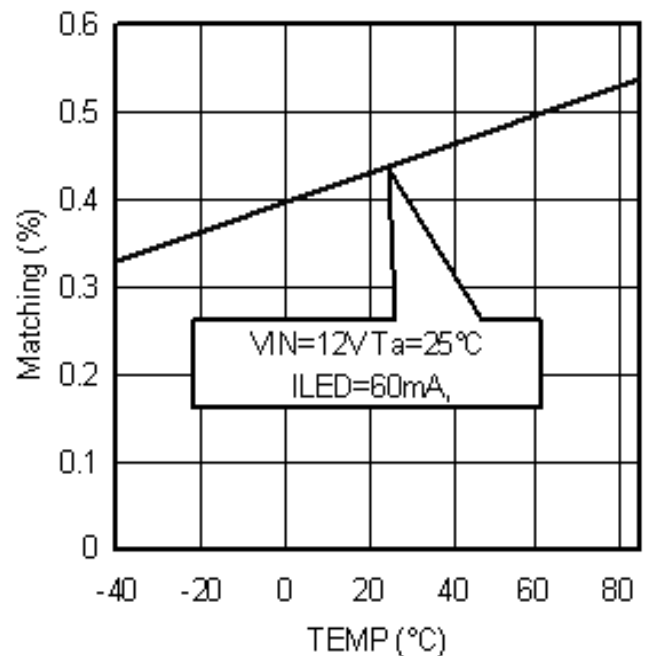

Figure 20. LED Current Matching

Typical Performance Curves - continued

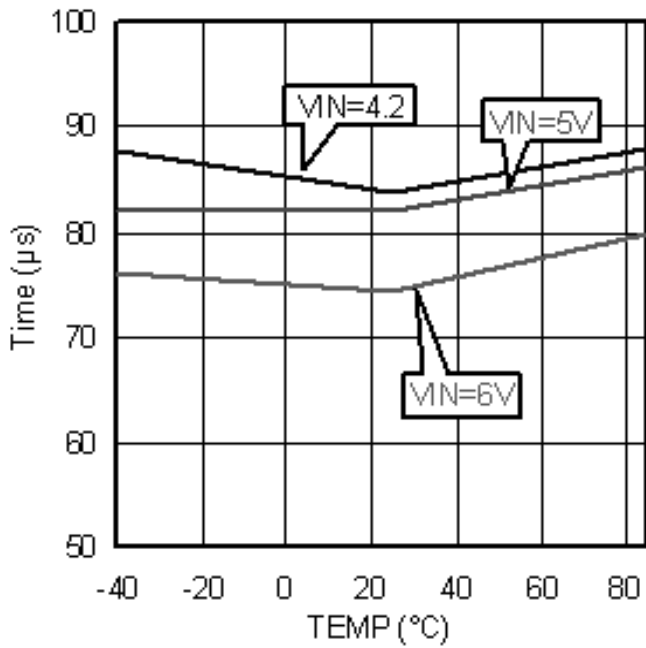

Figure 21. LED Open Time vs. Temp

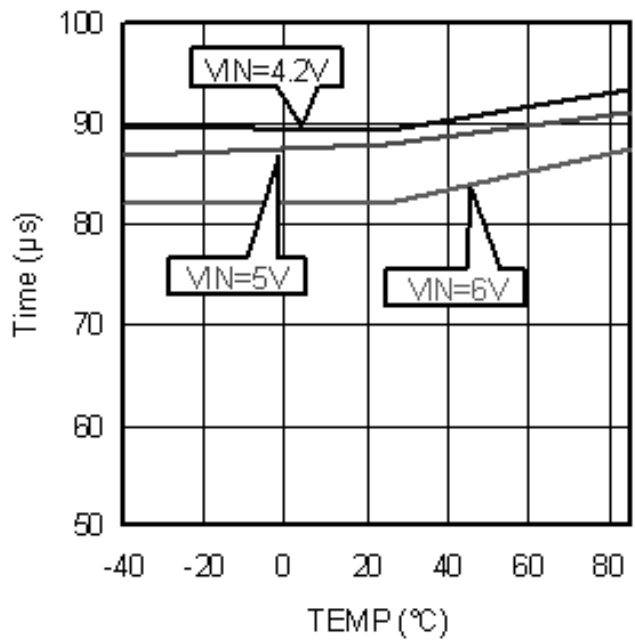

Figure 22. LED Short Time vs. Temp

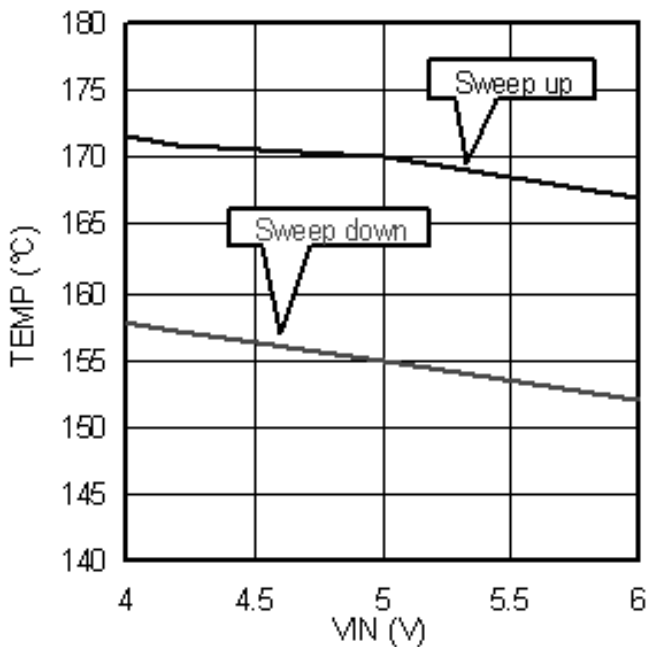

Figure 23. Thermal Shut Down

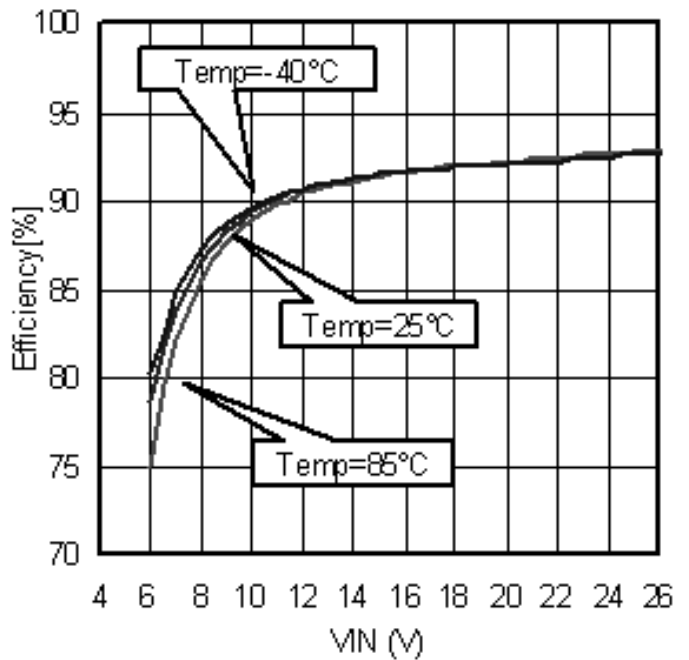

Figure 24. Efficiency 10LEDx4CH  
ILED=60mA

Typical Performance Curves - continued

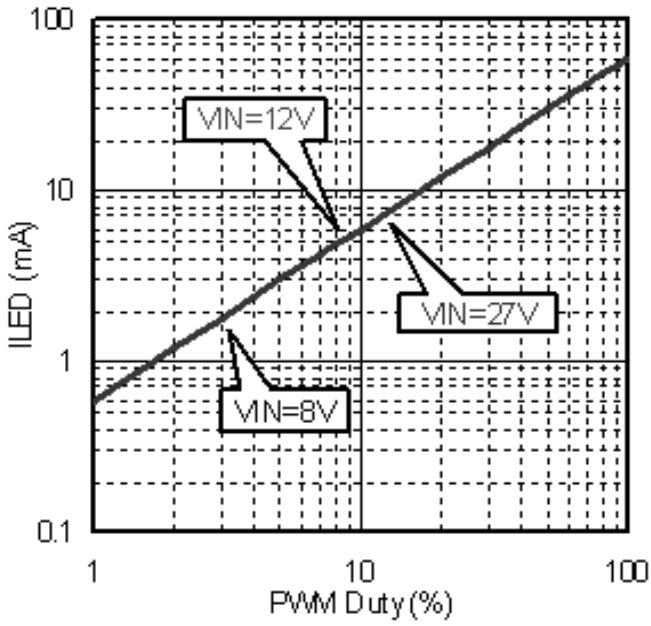

Figure 25. LED Current vs. PWM Duty  
 PWM Freq=200Hz FSET=56kΩ

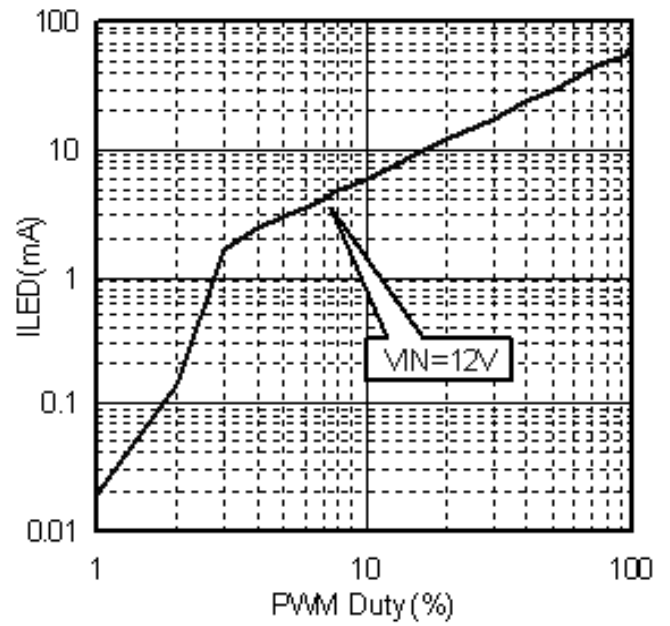

Figure 26. LED Current vs. PWM Duty  
 PWM Freq=30kHz FSET=56kΩ

Application Example

Figure 27, Figure 28 and Figure 29 are Application examples. Recommended schematics and Layout are shown in page 29, 31.

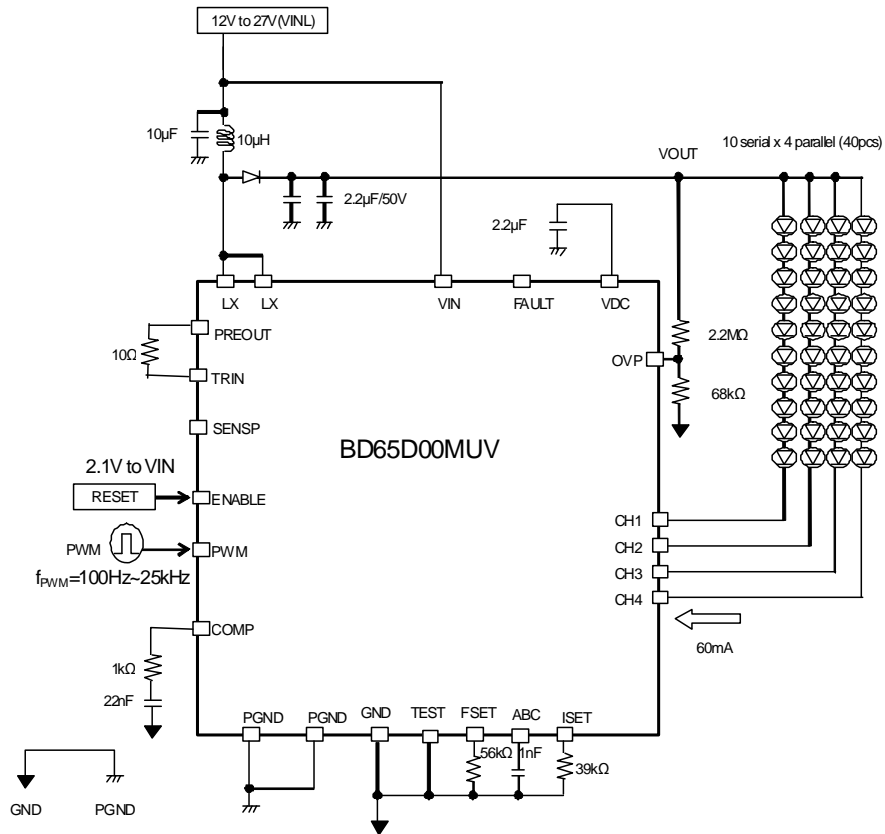

Figure 27. BD65D00 Application example (4 parallel)

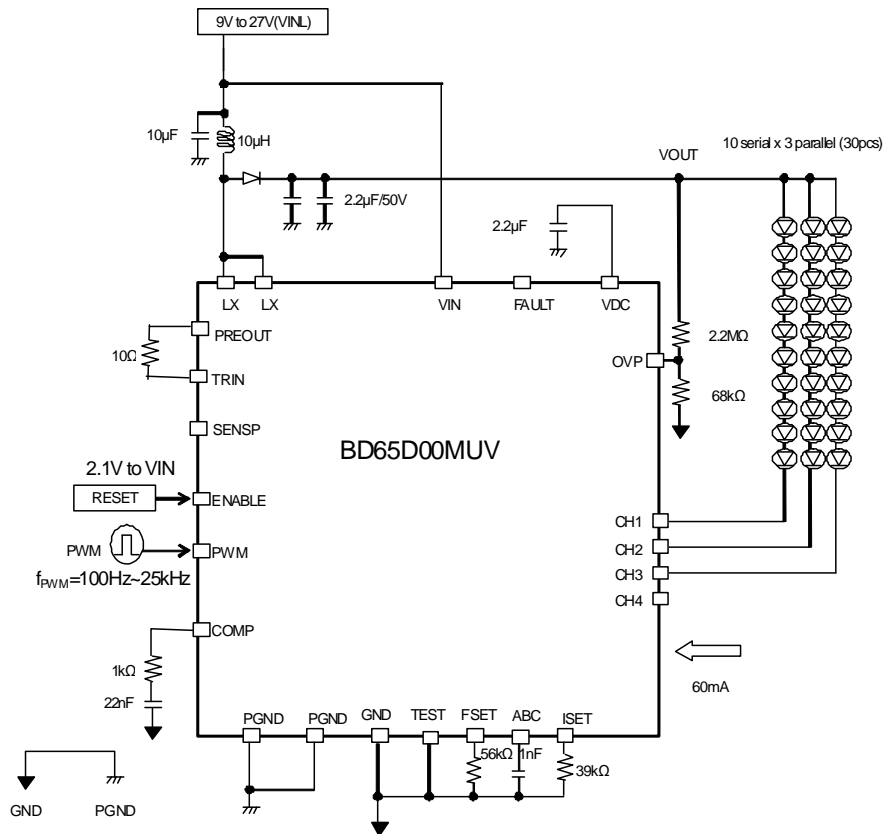

Figure 28. BD65D00 Application example (3 parallel)

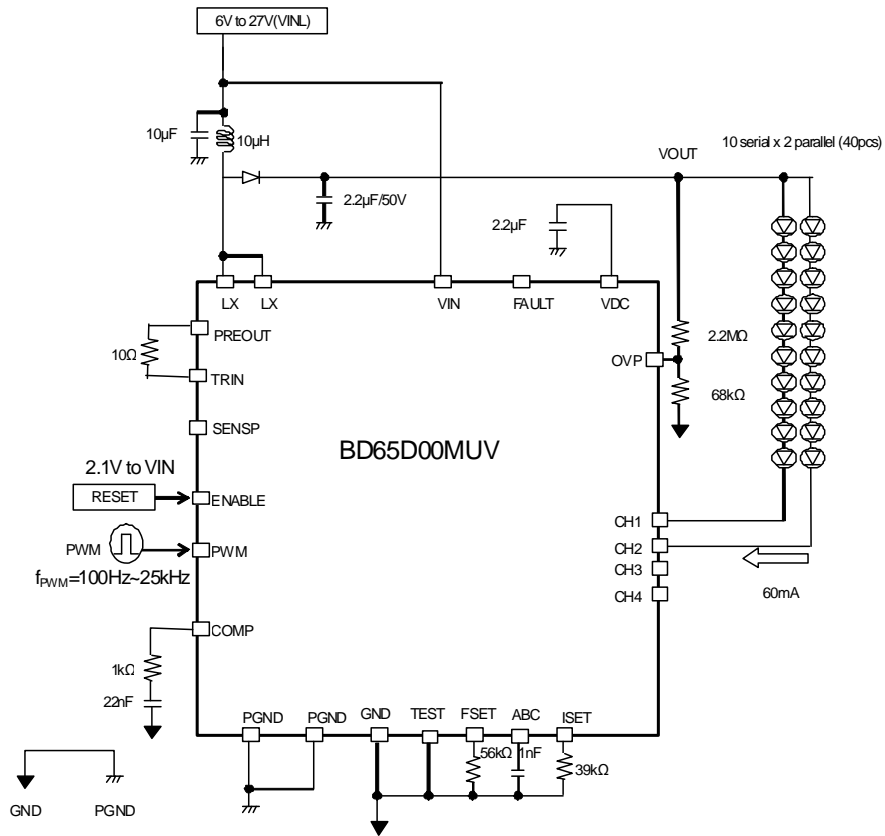

Figure 29. BD65D00 Application example (2 parallel)

Functional Descriptions

1) PWM current mode DC/DC converter

This detects the lowest voltage inside CH 1,2,3,4 pin voltage during power on. PWM duty is decided to be 0.8V and output voltage is kept invariably. As for the input soft the PWM comparator as the feature of the PWM current mode, one is overlapped with error components from the error amplifier, and the other is overlapped with a current sense signal that controls the inductor current into Slope waveform to prevent sub harmonic oscillation. This output controls internal Nch Tr via the RS latch. In the period where internal Nch Tr gate is ON, energy is accumulated in the external inductor, and in the period where internal Nch Tr gate is OFF, energy is transferred to the output capacitor via external SBD. This IC has many safety functions, and their detection signals stop switching operation at once.

2) Pulse skip control

This IC regulates the output voltage using an improved pulse-skip. In “pulse-skip” mode the error amplifier disables “switching” of the power stages when it detects low output voltage and high input voltage. The oscillator halts and the controller skip switching cycles. The error amplifier reactivates the oscillator and starts switching of the power stages again when this IC detects low input voltage.

At light loads a conventional “pulse-skip” regulation mode is used. The “pulse-skip” regulation minimizes the operating current because this IC does not switch continuously and hence the losses of the switching are reduced. When the error amplifier disables “switching”, the load is also isolated from the input. This improved “pulse-skip” control is also referred to as active-cycle control.

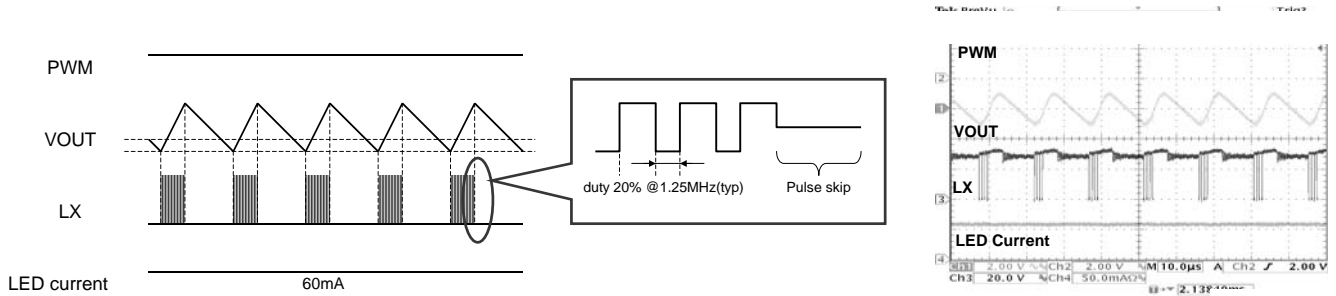

Figure 30. Pulse-skip

3) Soft start

This IC has soft start function.

The soft start function prevents large coil current.

Rush current at turning on is prevented by the soft start function.

The soft start of this IC controls over-current setting hence peak is controlled. Therefore, before switching phenomenon (not pulse-skip phenomenon) occurs, soft start (the phenomenon where-in current flows to the coil) will not start (stop).

Pulse-skip can release soft-start if the switching ON/OFF time is set.

After changing ENABLE pin, PWM pin from ‘L’→ ‘H’, regulator (VDC) voltage increases. Soft start is effective within the period 4.3ms when UVLO is detected and when it exceeds VDC=3.9V (typ.). Once soft start is finished, even if you change PWM from ‘L’ → ‘H’, soft start does not work.

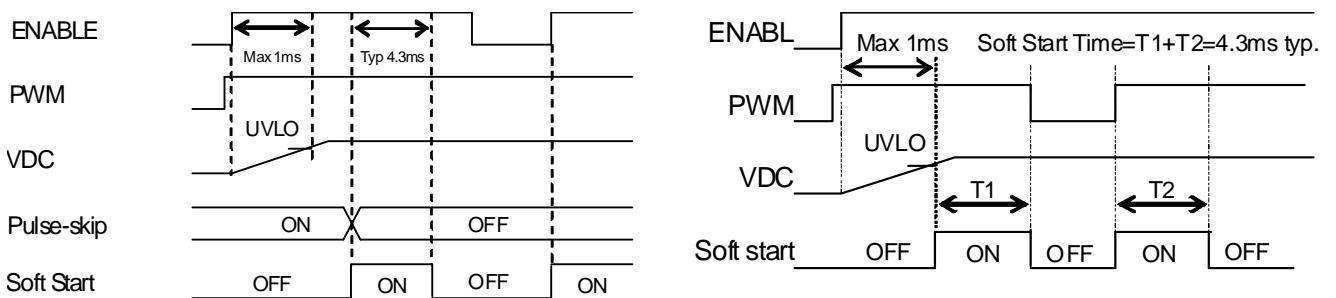

Figure 31. Soft start

4) FAULT

When the error condition occurs, boost operating is stopped by the protection function avoiding error condition. "L" is outputted from FAULT pin when an error occurs. After power-on, until soft start is released, around 4.3ms (typ.), protection functions do not operate (except TSD).

When ENABLE pin is changed to 'L', even if output of Fault pin latches, it will still reset to the initial status.

(In pulse-skip state, while the switching is stopped, the mask time of the FAULT pin becomes longer since the soft start is also stopped.) When using 3 parallel connection of LED in less than 4.3ms (typ.), the FAULT pin will output "L" if the process of the unused pin is not yet finished. Evaluate sufficiently the start up time when the connected capacitor between COMP pin & GND starts up smoothly.

Object of protect function is as shown below.

- Over-voltage protection (OVP)
- Thermal shut down (OTP)
- Over current protect (OCP)
- Output short protect
- LED Short (Latch)
- LED Open (Latch)

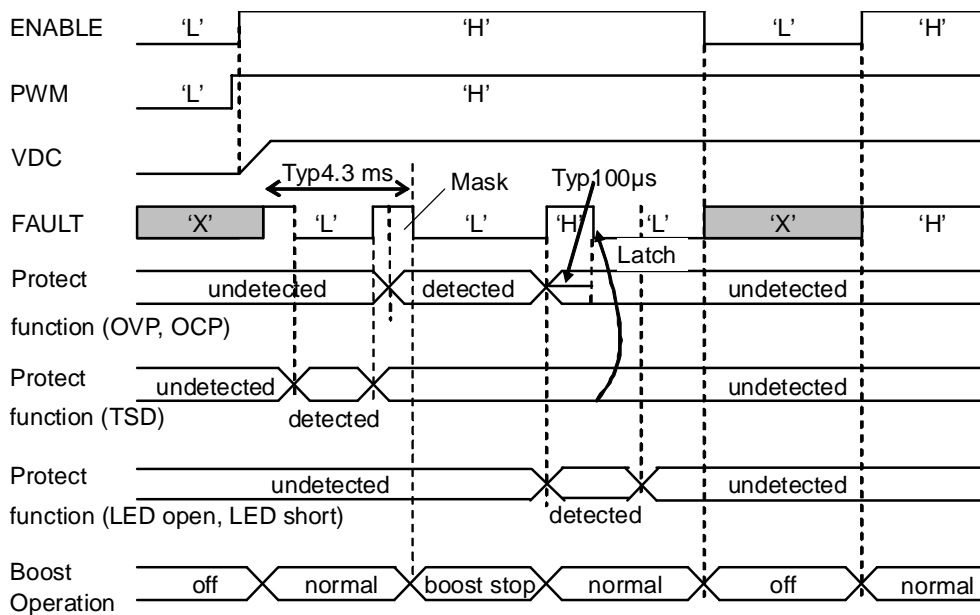

Figure 32. FAULT operating description

Protection

PROTECTION TABLE

CASE	FAILURE MODE	DETECTION MODE	CH1 pin	CH2 to 4 Pin	VOUT Adjustment	FAULT Terminal
1	LED Short ( LED CH1 is Short)	CH1 > VSC	LED current stop and DC/DC feedback doesn't return	Normal Burning DC/DC feedbacks at CH2 to CH4	Adjust VF of LED at CH2 to CH4 at the biggest line	'H' → 'L' (Latch)
2	LED OPEN ( LED CH1 is Open)	CH1 < 0.2V(typ.) and OVP > 1.2V(typ.)	LED current stop and DC/DC feedback doesn't return	Normal Burning DC/DC feedbacks at CH2 to CH4	Adjust VF of LED at CH2 to CH4 at the biggest line	'H' → 'L' (Latch)
3	VOUT/LX GND SHORT	OVP < 50mV(typ.)	FAULT change from 'H' to 'L', and switching is stopped. When OVP>50mV, FAULT return 'H'		-	'H' → 'L'
4	Output LED stack voltage too high	OVP > 1.2V(typ.)	FAULT change from 'H' to 'L', and switching is stopped. OVP<1.2V, FAULT returns to 'H' (does not return when it occurs at the same time with LED open)		-	'H' → 'L'
5	LX current too high	OCP > 2.5A or OTP > 175°C(typ.)	FAULT change from 'H' to 'L', and switching is stopped. Fault pin does not returns to 'H' because IC shutdowns and when ENABLE is from 'H' to L until 'H'.		-	'H' → 'L'

▪ Over voltage protection (OVP)

When LED is separated it will result to output open and over step-up. When the built-in (external) Tr and OVP pin exceed the absolute maximum rating, the built-in (external) Tr and IC will break down. Thus, OVP pin when more than the detect voltage will turn into over voltage protection status turning off switching and stopping DC/DC.

After over voltage protection, as shown in Figure 33, the IC changes from activation into non-activation, and the output voltage goes down slowly. And when the Feedback of CH1 isn't returned, feedback takes place in CH2.

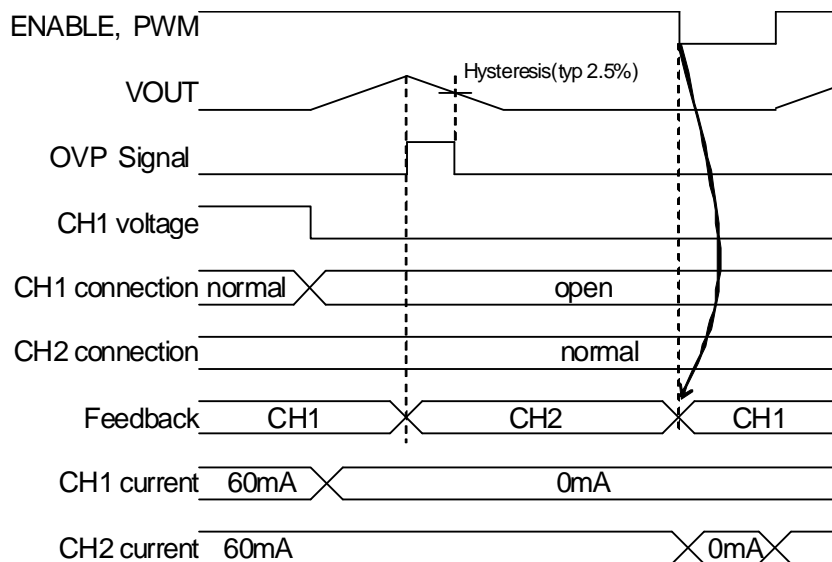

Figure 33. OVP operating description

The value shown in electrical characteristics is used here.

Over voltage limit	min 1.16V	typ 1.20V	max 1.24V
LED control voltage	min 0.64V	typ 0.80V	max 0.96V
LED terminal over voltage protect	min 6.80V	typ 8.00 V	max 9.20V

- Calculate the condition of the total value of LED VF.  
Example) In the case of serial 8 LEDs with VF=2.9V (min), 3.2V (typ.), 3.5V (max) => 3.5V x 8=28V
- Then calculate the biggest value of output with the following formula.  
The biggest value of output = the biggest value calculated in #1 + the biggest value of LED terminal voltage. (0.96V)  
Example) The biggest value of output = 28V + 0.96V =28.96V
- Set the smallest value of over voltage larger than the biggest value of output.  
If over voltage is closer to the total value of VF, it could be occurred to detect over voltage by ripple, noise, and so on. It is recommended that some margins should be left on the difference between over voltage and the total value of VF. This time around 6% margin is placed.  
Example) Output largest value = 28.96V, the smallest value of over voltage = 28.96V x 1.06 = 30.70V  
Ic over voltage limit min=1.16V, typ=1.20V, max=1.24V  
typ = 30.70Vx(1.20V/1.16V) = 31.76V  
max = 31.76Vx(1.26V/1.20V) = 33.35V
- Below shows how to adjust setting resistor value.  
Please fix resistor high between OVP terminal and output and then set over voltage after changing resistor between OVP terminal and GND. If this resistor value is decreased, output voltage will also decrease while PWM is turned OFF, hence ripple of output voltage becomes larger and the sound/noise of output capacitor also increases.

Example) Selecting OVP resistor (R1 and R2).

#### • OVP resistor selection

(Example. 1) VF=3.5V max, serial = 7 LED  
OVP = 1.2V, R1 = 2.2MΩ, R2 = 95.3kΩ  
VOUT = 1.2 x (2.2MΩ + 95.3kΩ)/ 95.3kΩ = 28.90V

(Example. 2) VF=3.5V max, serial = 8 LED  
OVP = 1.2V, R1 = 2.2MΩ, R2 = 82kΩ  
VOUT = 1.2 x (2.2MΩ + 82kΩ)/ 82kΩ = 33.40V

(Example. 3) VF=3.5V max, serial = 9 LED  
OVP = 1.2V, R1 = 2.2MΩ, R2 = 73.2kΩ  
VOUT = 1.2 x (2.2MΩ + 73.2kΩ)/ 73.2kΩ = 37.27V

(Example. 4) VF=3.5V max, serial = 10 LED  
OVP = 1.2V, R1 = 2.2MΩ, R2 = 68kΩ  
VOUT = 1.2 x (2.2MΩ + 68kΩ)/ 68kΩ = 40.02V

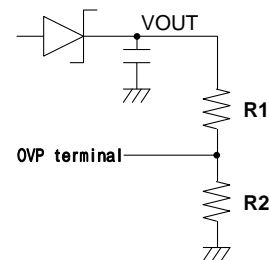

▪ Over Current Protection

Over current flows in current detect resistor that is connected between internal switching Tr source and PGND. When it increases beyond detect voltage, over current protect operates. Over current protect prevents it becoming more than detect voltage by reducing on Duty of switching Tr without stopping boosting operation.

Since the over current detector of this IC detects peak current, more than setting value of over current doesn't flow.

If both PWM=H (boosting condition) and over current situation keep going during continuous 2ms, the IC shuts down. By making ENABLE 'H'-'L'-'>'H', the IC activates again. The IC might shut down if boosting operation starts with slow speed of power supply activation and also low voltage. Please operate after setting input voltage that is required for application.

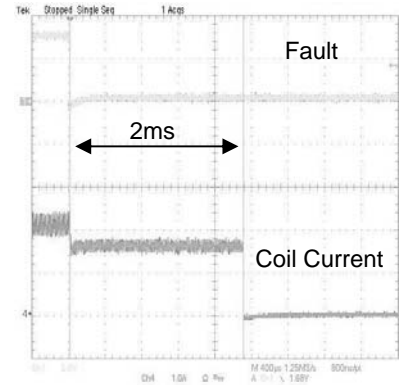
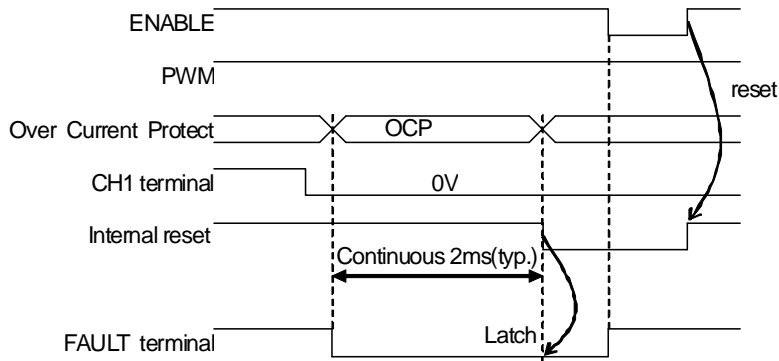

▪ External SBD open detect / Output Short protection

If in case external SBD and DC/DC output (VOUT) connection is open, or VOUT is shorted in GND, there is a risk that coil and the internal Tr might break down. Therefore, at such an error as OVP becoming 50mV (typ.) or below, turns off the output Tr, and prevents the coil and the IC from being destructed.

And the IC changes from activation into non-activation, current does not flow to the coil (0mA).

▪ Thermal shut down

This IC has thermal shut down function.

The thermal shut down works at 175°C (typ.) or higher, and the IC changes from activation into non-activation.

**Operating of the Application Deficiency**

1) When 1 LED or 1string OPEN during the operation

The LED string which became OPEN isn't lighting (e.g. CH1), but other LED strings are lighting.

As shown in Figure 34, when the strings in CH1 are open, CH1 pin become 0V. The lowest voltage is below 0.8V thus the output will boost up to over voltage protection voltage. When over voltage protect is detected, open process starts. Once OPEN, since the pin which is the object of the feedback is excluded, VOUT returns to normal voltage.

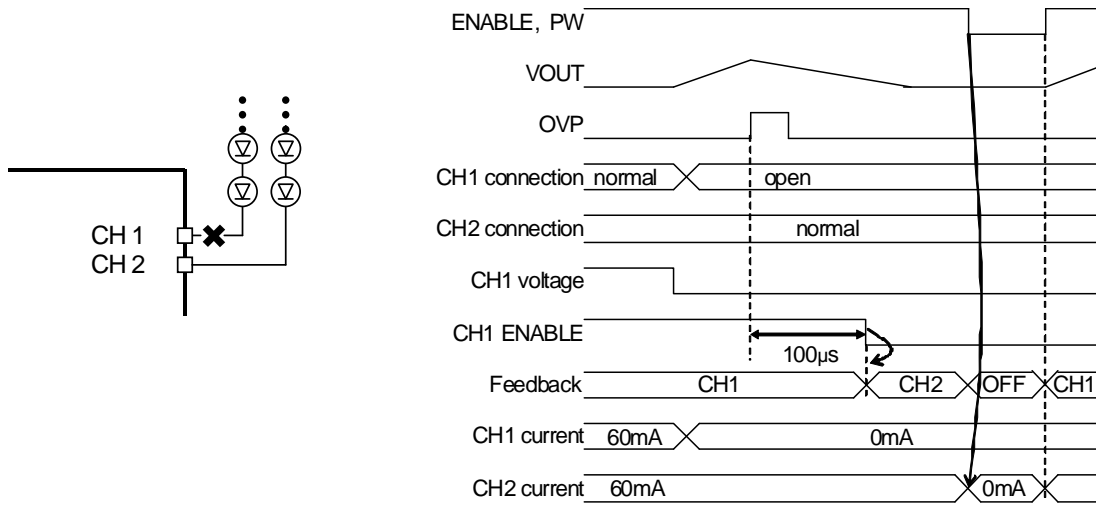

Figure 34. LED open protect

2)When LED short-circuited in multiple

All LED strings are lighted unless CH1 to 4 terminal voltage is more than 8V(typ.).

When it was more than 8V only the strings which short-circuited are turned off, LED current strings of other lines continue to turn on normally. Short line (CH1) current is changed from 60mA to 0.05mA (typ.), so CH1 terminal don't heat.

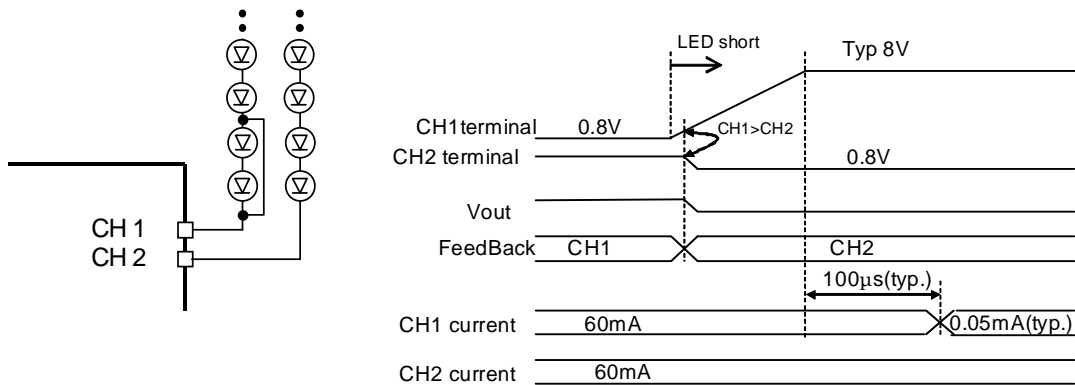

Figure 35. LED short protect

3)When Schottky diode remove

IC breakdown is prevented by stopping boost operation thru Schottky diode protection function (OVP pin <50mV).

Control Signal Input Timing

Timing sequence1

Figure 36. shows the Power ON sequence. ENABLE and PWM signal from 'L' to 'H' after charging current (VIN ON). Power OFF sequence, on the other hand, is turning OFF power supply (VIN) after ENABLE and PWM Signal turns from H to L.

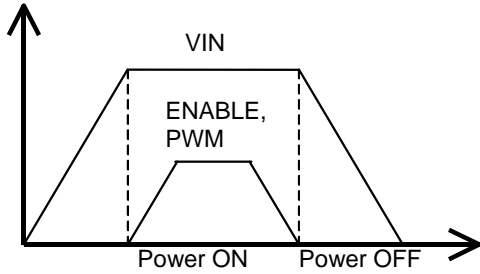
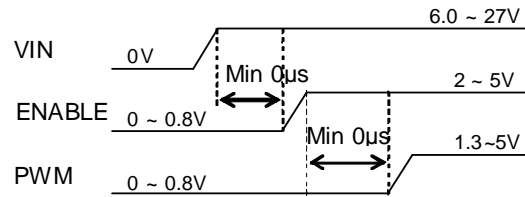

Figure 36. Timing sequence1

LED IC Timing Sequence for PWM Control Turn-on



\*other signals are inputted after signals are turned on.

LED IC Timing Sequence for PWM Control Turn-off

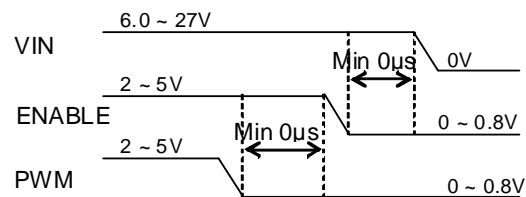

\*other signals are inputted after signals are turned off.

Timing sequence2

Figure 37. shows the Power ON sequence. Power Supply charge (VIN ON), ENABLE signals from L to H, then PWM signal from L to H. Power OFF sequence, on the other hand, is turning OFF power supply (VIN) and ENABLE, PWM signal from H to L.

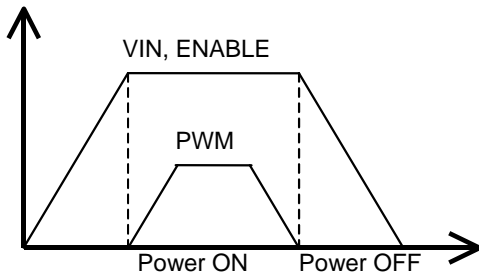
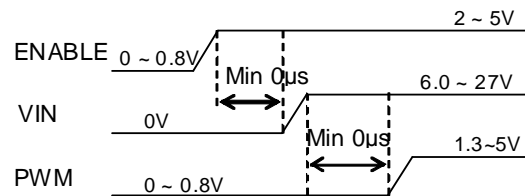

Figure 37. Timing sequence2

LED IC Timing Sequence for PWM Control Turn-on



\*other signals are inputted after signals are turned on.

LED IC Timing Sequence for PWM Control Turn-off

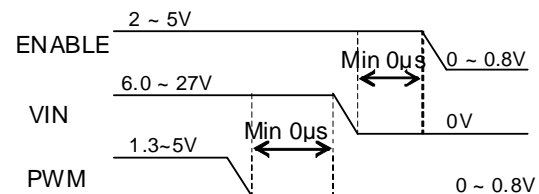

\*other signals are inputted after signals are turned off.

Timing sequence3

Figure 38.shows Power ON sequence. Power supply charge (VIN ON), PWM from L to H, then afterwards ENABLE signal from L to H. Power OFF sequence is power supply (VIN) OFF, PWM signal from H to L then ENABLE signal from H to L.

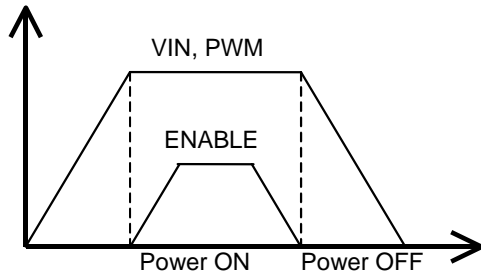
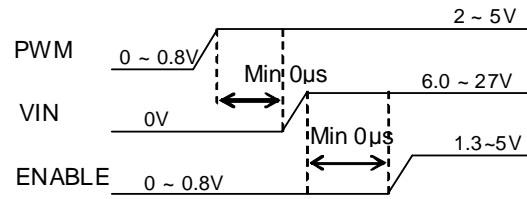

Figure 38. Timing sequence3

LED IC Timing Sequence for PWM Control Turn-on



\*other signals are inputted after signals are turned on.

LED IC Timing Sequence for PWM Control Tn

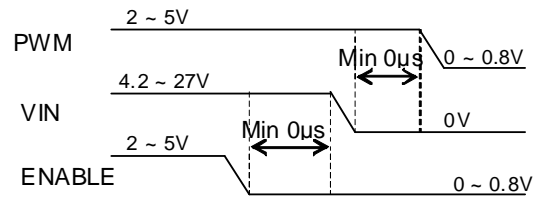

\*other signals are inputted after signals are turned off.

VIN wake up speed

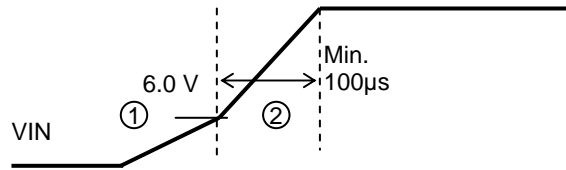

Figure 39. Control Signal timing

In case there is PWM OFF status (min: 10ms) during operation, ENABLE is reset ('H' to 'L') as shown in Figure 40. If PWM stops and VOUT voltage is dropped, this IC will be in current limiter state when PWM starts (no soft start). If soft start is not necessary, there is no need also to reset.

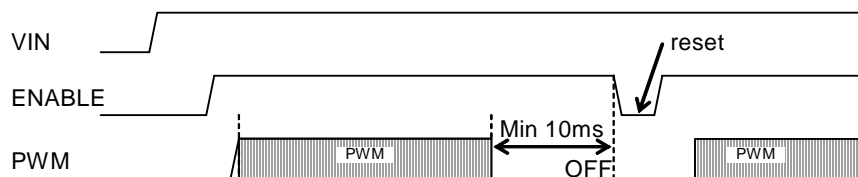

Figure 40. PWM stop and ENABLE turn "off"

**How to Activate**

Pay attention to the following when activating.

- Regulator (VDC) is operated after ENABLE=H. Inner circuit is operated after releasing UVLO. When boosting after releasing UVLO, soft start function is operated. Soft start circuit needs  $t_{15}$  (more than  $5\mu s$ ) such as Figure 41. Soft start is operated during  $t_{soft}$  time. Set PWM width "H" until soft start finishes.

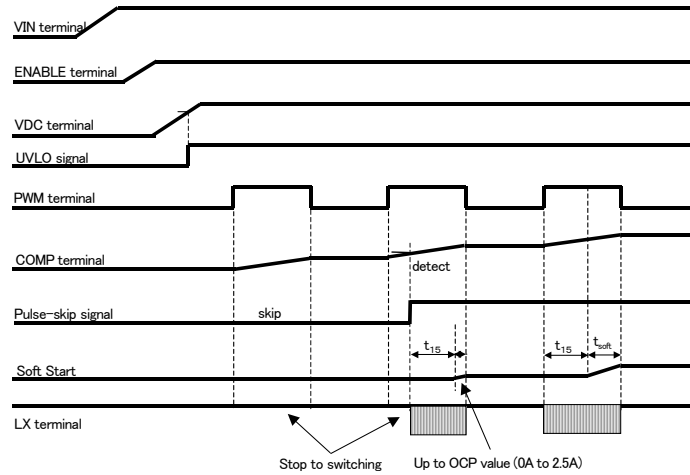

Figure 41. Soft Start

Example: Time until soft start finishes at PWM frequency 25kHz and PWM=H time is  $6\mu s$

By soft start time typ 4.3ms

$t_{soft} = 6\mu s - 5\mu s = 1\mu s$

Soft start time /  $t_{soft}$  / PWM frequency =  $4300\mu s / 1\mu s / 25kHz = 172ms$

At dimming with PWM terminal (after soft start finishes)

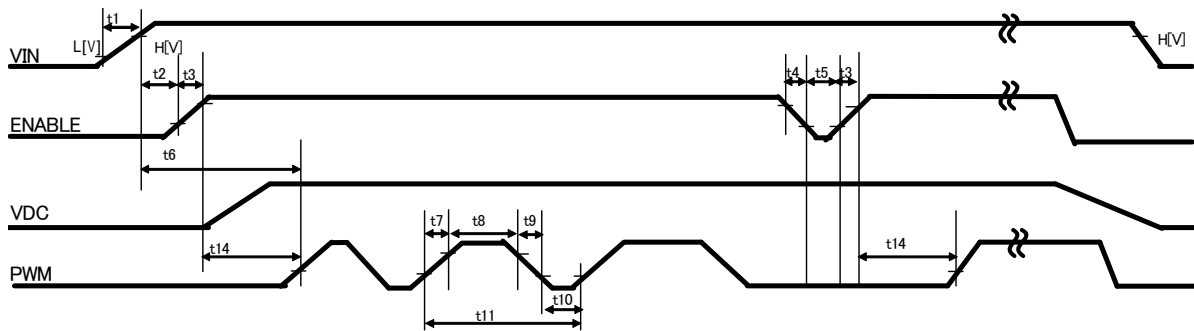

Figure 42. Timing Input (after soft start)

	Name	Unit	Min.	Typ.	Max.
t1	Power Supply Rise Time	$\mu s$	100	-	-
t2	Power Supply - ENABLE Rise Time	$\mu s$	0	-	-
t3	ENABLE Rise Time	$\mu s$	0	-	100
t4	ENABLE Fall Time	$\mu s$	0	-	100
t5	ENABLE Low Width	$\mu s$	50	-	-
t6	Power Supply - PWM Time	$\mu s$	0	-	-
t7	PWM Rise Time	$\mu s$	0	-	100
t8	PWM High Width	$\mu s$	5	-	-
t9	PWM Fall Time	$\mu s$	0	-	100
t10	PWM Low Width	$\mu s$	5	-	-
t11	PWM Cycle	$\mu s$	40	5000	10000
t12	ENABLE(H)->PWM(H) Time	$\mu s$	0	-	-
t13	ENABLE(L)->PWM(L) Time	$\mu s$	0	-	-
t14	PWM(L)->ENABLE(L) Time	$\mu s$	0	-	-
t15	Soft Start Set Up Time	$\mu s$	5	-	-
H	Operation Voltage	V	4.2	12	27
L	No Operation Voltage	V	-	-	4.2

**How to Select the Number of LED Strings of the Current Driver**

In order to reduce the number of strings of current driver, open unnecessary CH1 to 4 pins for them not to be selected. When using 2 strings, open the unnecessary 2 strings.

During VOUT wake up in an open state, VOUT boost up until OVP voltage. Once IC detect OVP, VOUT don't boost up until OVP from next start up. If ENABLE set to 'L,' IC resets CH4 status as shown Figure 43. Also during VOUT wake up, CH4 (open terminal) and CH1 are selected as shown Figure 44.

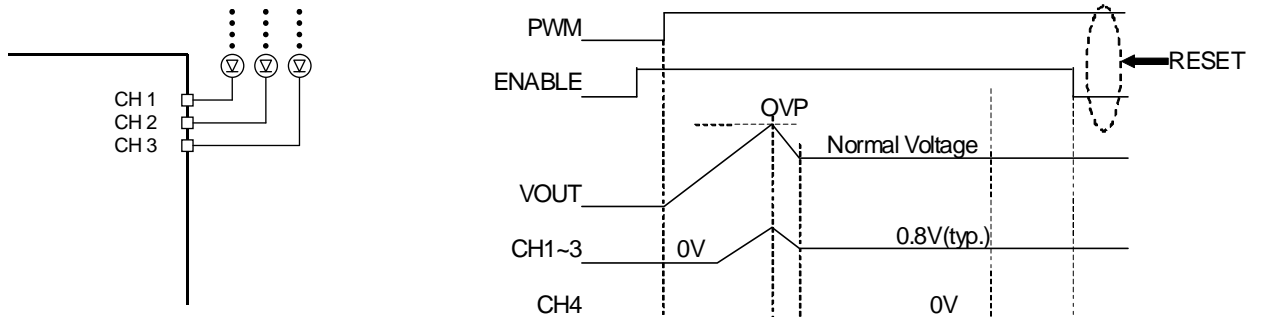

Figure 43. Select the number of CH1 strings

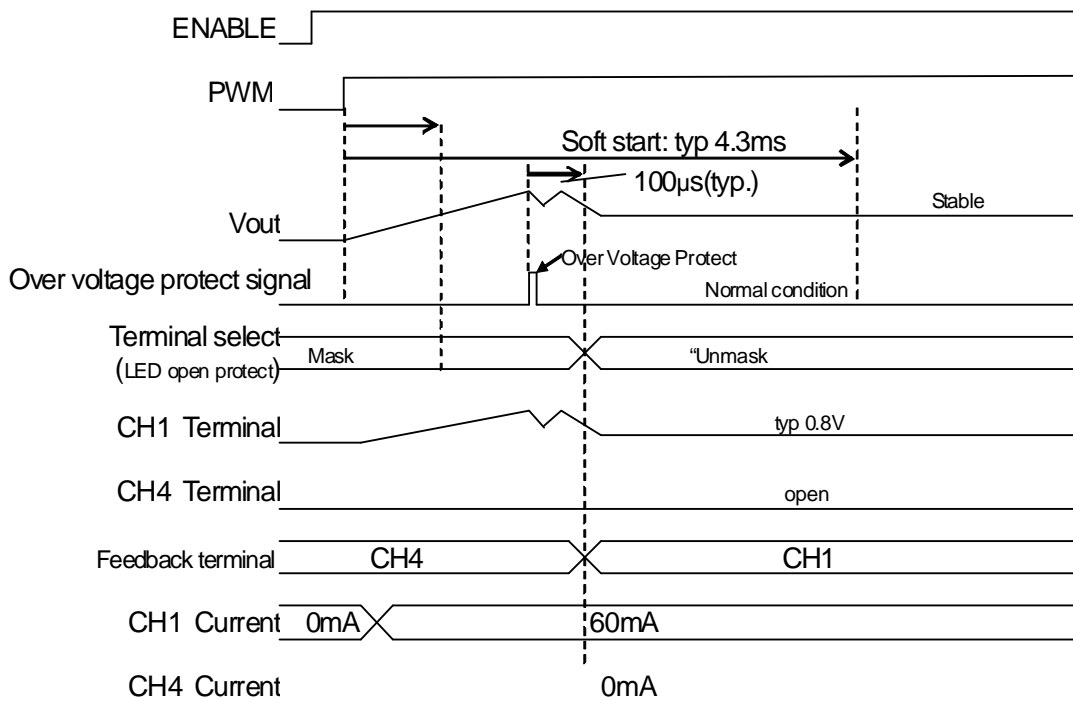

Figure 44. Select the number of CH4 strings (wake up)

**Start Control (ENABLE) and LED Current Driver Selection (PWM)**

This IC can control the IC system by ENABLE, and IC can power off compulsory by setting 0.8V or below. Also, It powers on ENABLE is at more than 2.0V.  
 After it's selected to ENABLE=H, When it is selected at PWM=H, LED current decided with ISET resistance flow.  
 Next, When it is selected at PWM=L, LED current stop to flow.

ENABLE	PWM	IC	LED current
0	0	Off	OFF
1	0	On	OFF
0	1	Off	OFF
1	1	On	Current decided with ISET

**LED Current Setting Range**

Normal Current setting is done thru resistor (RISET) connected to voltage of ISET.  
 Setting of each LED current is given as shown below.

$$RISET = 2340 / ILEDmax$$

Also, Normal current setting range is 30mA to 100mA. LED current becomes a leak current MAX 2µA at OFF setting.

**ISET Normal current setting example**

RISET	LED current
24kΩ (E24)	97.5mA
30kΩ (E24)	78.0mA
39kΩ (E24)	60.0mA
43kΩ (E24)	54.4mA
68kΩ (E24)	34.4mA

**Frequency Setting Range**

Switching frequency can be set by connecting the resistor to FSET pin.  
 Also, Frequency setting range is 0.60MHz to 1.60MHz.

The below diagrams are the reference data that shows what happens when FSET terminal is connected to resistor.

**FSET frequency setting example**

RFSET	Frequency
130kΩ (E96)	0.57MHz
56kΩ (E24)	1.25MHz
43kΩ (E24)	1.59MHz

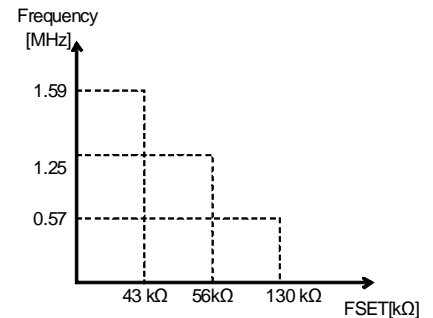

**Max Duty example**

Frequency	Max Duty[%]		
	Min	Typ	Max
600MHz	-	96.0	-
1.25MHz	91.0	95.0	99.0
1.6MHz	-	92.0	-

**Min Duty example**

Frequency	Min Duty[%]		
	Min	Typ	Max
1.25MHz	-	20	-

**PWM Dimming**

Current driver PWM control is controlled by providing PWM signal to PWM port, as it is shown Figure 45. The current set up with ISET is chosen as the H section of PWM and the current is off as the L section. Therefore, the average LED current is increasing in proportion to duty cycle of PWM signal. This method that it lets internal circuit and DC/DC to work, because it becomes to switch the driver, the current tolerance is a few when the PWM brightness is adjusted, it makes it possible to brightness control until 5μs (Min 0.1% at 200Hz). And, don't use for the brightness control, because effect of ISET changeover is big under 1μs ON time and under 1μs OFF time. Typical PWM frequency is 100Hz to 25kHz.

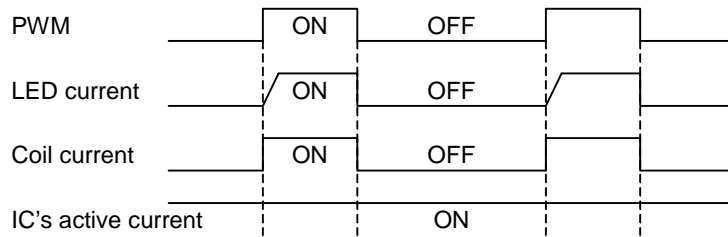

Figure 45. PWM sequence

**Analog Dimming**

This IC controls LED current thru an analog input (ABC terminal). LED current is determined thru the resistor connected to ISET. Normal state is ABC voltage= typ 0.733V. Decrease LED current to decrease ABC voltage and increase LED current to increase ABC voltage.

In order to get the MAX value of LED current, follow the setting range of LED current found in page 18. Be careful that the setting LED current Max value is ABC voltage=0.733V (typ.). ABC input range is 0.05V ~ 0.9V. This dimming is effected by ISET tolerance.

When analog dimming is not used, connect capacitor to ABC terminal. LED current increases until charging of the capacitor at the ABC terminal is finished. The resistor between 1.2V and ABC terminal is 120.9kΩ. Take into consideration the charge time before deciding the capacitor value.

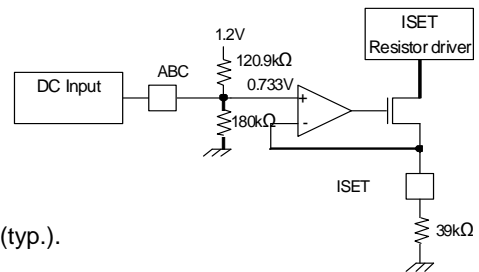

Figure 46. Analog dimming application

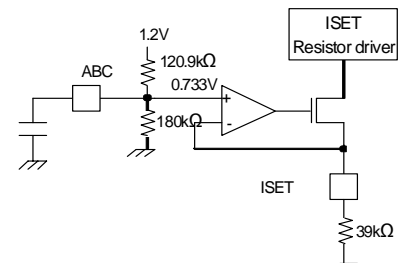

Figure 47. PWM dimming application

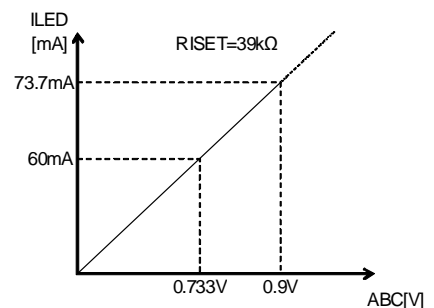

Figure 48. ILED vs. ABC voltage

## Coil Selection

The DC/DC is designed by more than 4.7μH. When "L" value sets to a lower value, it is possibility that the specific sub-harmonic oscillation of current mode DC / DC will be happened. Do not let "L" value to 3.3μH or below.

When "L" value increases, the phase margin of DC / DC becomes zero. Please enlarge the output capacitor value when you increase "L" value. Make the resistor component smaller in order to increase the efficiency of DCR Inductor. Please estimate Peak Current of Coil as shown in the examples below.

### Peak Current calculation

<Estimate of the current value which is needed for the normal operation>

As over current detector of this IC is detected the peak current, it have to estimate peak current to flow to the coil by operating condition.

In case of,

- Supply voltage of coil =  $V_{in}$
- Switching frequency = fsw (Min=1.0MHz, Typ = 1.25MHz, Max = 1.5MHz)
- Output voltage =  $V_{OUT}$
- Average current of coil =  $I_{ave}$
- Cycle of Switching = T
- ON time of switching transistor =  $T_{on}$
- Inductance value of coil = L
- Total LED current =  $I_{LED}$
- Peak current of coil =  $I_{peak}$
- Efficiency = eff (Please set up having margin)
- ON Duty = D

The relation is shown below:

CCM:  $I_{peak} = (V_{in} / L) \times (1 / f_{sw}) \times (1 - (V_{in} / V_{OUT}))$ , DCM:  $I_{peak} = (V_{in} / L) \times T_{on}$

$I_{ave} = (V_{OUT} \times I_{OUT} / V_{in}) / \text{eff}$

$T_{on} = (I_{ave} \times (1 - V_{in} / V_{OUT}) \times (1 / f_{sw}) \times (L / V_{in}) \times 2)^{1/2}$

Each current is calculated.

As peak current varies according to whether there is the direct current superposed, the next is decided.

CCM:  $(1 - V_{in} / V_{OUT}) \times (1 / f_{sw}) < T_{on} \rightarrow \text{peak current} = I_{peak} / 2 + I_{ave}$

DCM:  $(1 - V_{in} / V_{OUT}) \times (1 / f_{sw}) > T_{on} \rightarrow \text{peak current} = V_{in} / L \times T_{on}$

(Example 1)

In case of,  $V_{in} = 12V$ ,  $L = 10\mu H$ ,  $f_{sw} = 1.25MHz$ ,  $V_{OUT} = 32V$ ,  $I_{LED} = 240mA$ , Efficiency = 88%

$I_{ave} = (32 \times 240m / 12) / 88\% = 0.7273A$

$T_{on} = (0.7273 \times (1 - 12 / 32) \times (1 / 1.25M) \times (10\mu / 12) \times 2)^{1/2} = 0.78\mu s$

$(1 - V_{in} / V_{OUT}) \times (1 / f_{sw}) = 0.5\mu s < T_{on}(0.78\mu s)$  CCM

$I_{peak} = (12 / 10\mu) \times (1 / 1.25M) \times (1 - (12 / 32)) = 0.6A$

Peak current =  $0.6A / 2 + 0.727A = 1.027A$

(Example 2)

In case of,  $V_{in} = 24.0V$ ,  $L = 10\mu H$ ,  $f_{sw} = 1.25MHz$ ,  $V_{OUT} = 32V$ ,  $I_{LED} = 120mA$ , Efficiency = 88%

$I_{ave} = (32 \times 120m / 24.0) / 88\% = 0.1818A$

$T_{on} = (0.1818 \times (1 - 24 / 32) \times (1 / 1.25M) \times (10\mu / 24) \times 2)^{1/2} = 0.17\mu s$

$(1 - V_{in} / V_{OUT}) \times (1 / f_{sw}) = 0.20\mu s > T_{on}(0.17\mu s)$  DCM

$I_{peak} = V_{in} / L \times T_{on} = 24 / 10\mu \times 0.17\mu s = 0.42A$

Peak current = 0.42A

### DCM/CCM calculation

Discontinuous Condition Mode (DCM) and Continuous Condition Mode (CCM) are calculated as following.

CCM:  $L > V_{OUT} \times D \times (1 - D)^2 \times T / (2 \times I_{LED})$

DCM:  $L < V_{OUT} \times D \times (1 - D)^2 \times T / (2 \times I_{LED})$

\* $D = 1 - V_{in} / V_{OUT}$

(Example 1)

In case of,  $V_{in} = 7.0V$ ,  $L = 10\mu H$ ,  $f_{sw} = 1.2MHz$ ,  $V_{OUT} = 32V$ ,  $I_{LED} = 240mA$

$V_{OUT} \times D \times (1 - D)^2 \times T / (2 \times I_{LED}) = 32 \times (1 - 7 / 32) \times (7 / 32)^2 \times 1 / (1.2 \times 10^6) / (2 \times 0.24) = 4.69\mu < L(10\mu H)$

$\rightarrow$  CCM

(Example 2)

In case of,  $V_{in} = 12.0V$ ,  $L = 10\mu H$ ,  $f_{sw} = 1.2MHz$ ,  $V_{OUT} = 32V$ ,  $I_{LED} = 60mA$

$V_{OUT} \times D \times (1 - D)^2 \times T / (2 \times I_{LED}) = 32 \times (1 - 12 / 32) \times (12 / 32)^2 \times 1 / (1.2 \times 10^6) / (2 \times 0.12) = 15\mu > L(10\mu H)$

$\rightarrow$  DCM

**OUTPUT Capacitor Selection**

Output Capacitor smoothly keeps output voltage and supplies LED current. Output Voltage consists of Charge (FET ON) and Discharge (LED current). So Output voltage has Output ripple Voltage in every FET switching. Output ripple voltage is calculated as following.

Output ripple Voltage

- Switching cycle = T
- Switching ON duty = D
- Output Capacitor = C<sub>OUT</sub>
- Decreasing ratio of Capacitor = C<sub>error</sub>
- Total LED current = I<sub>LED</sub>
- Output ripple Voltage = V<sub>ripple</sub>
- Output Capacitor (real value) = C<sub>real</sub>

$C_{real} = C_{OUT} \times C_{error}$  (Capacitor value is decreased by Bias, so)

$C_{real} = I_{LED} \times (1-D) \times T / V_{ripple}$

$C_{OUT} = I_{LED} \times (1-D) \times T / V_{ripple} / C_{error}$

(Example 1)

In case of, V<sub>IN</sub>=12.0V, f<sub>sw</sub> = 1.2MHz, V<sub>OUT</sub> =32V, I<sub>LED</sub> =120mA, C<sub>OUT</sub> = 8.8μF, C<sub>error</sub> = 50%

$T = 1 / 1.2MHz$

$D = 1 - V_{IN} / V_{OUT} = 1 - 12/32$

$V_{ripple} = I_{LED} \times (1-D) \times T / (C_{OUT} \times C_{error}) = 120mA \times (12/32) / 1.2MHz / (8.8\mu F \times 0.5)$   
 $= 8.5mV$

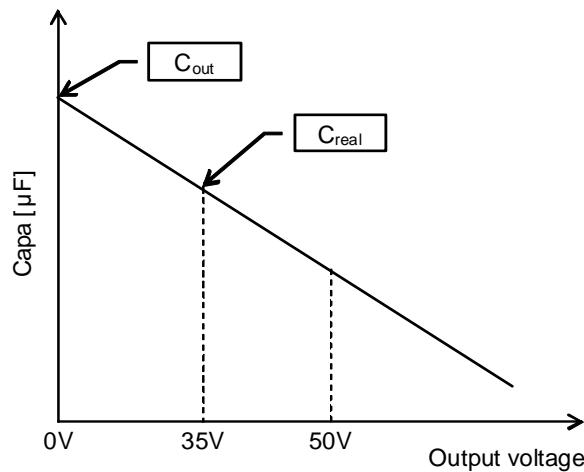

Figure 49. Bias Characteristics of Capacitor

**The Separations of the IC Power Supply and Coil Power Supply**

This IC can work in separating the power source in both IC power supply and coil power supply. With this application, it can decrease IC power consumption, and can correspond to applied voltage exceeds IC rating 27V.

That application is shown in below Figure 50. The higher voltage source is applied to the power source of coil that is connected from an adapter etc. Next, the IC power supply is connected with a different coil power supply. Under the conditions for inputting from 4.5V to 5.5V into IC VIN, please follow the recommend design in Figure 50. It connects VIN terminal and VDC terminal together at IC outside.

When the coil power supply is applied, there is no any problem even though IC power supply is the state of 0V. Although IC power supply is set to 0V, pull-down resistance is arranged for the power off which cuts off the leak route from coil power supply in IC inside, the leak route is cut off. And, there is no power on-off sequence of coil power supply and IC power supply.

However, there's an instance where the over current protection may be affected if the power supply was inputted last in the coil because the ENABLE and PWM were inputted already and also because of under voltage that was detected before the power supply stabilizes. Before it reaches the needed voltage in the applications to be used, turn OFF the ENABLE and PWM input.

**Separate VIN and Coil power supply**

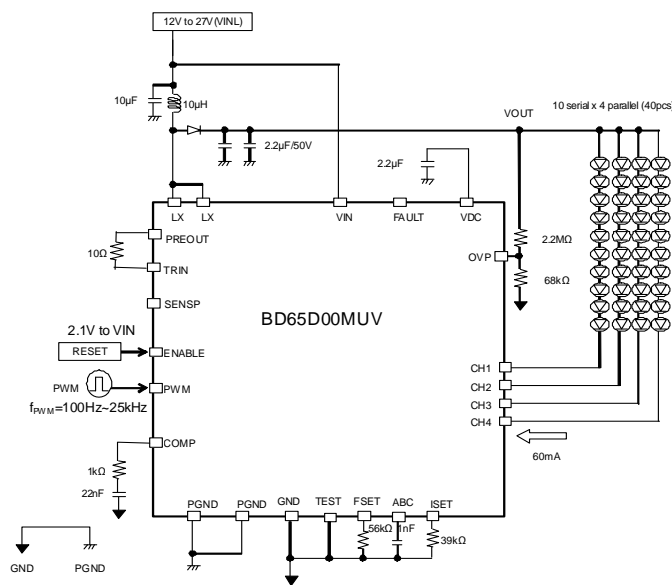

**Connect VIN and VDC terminals**

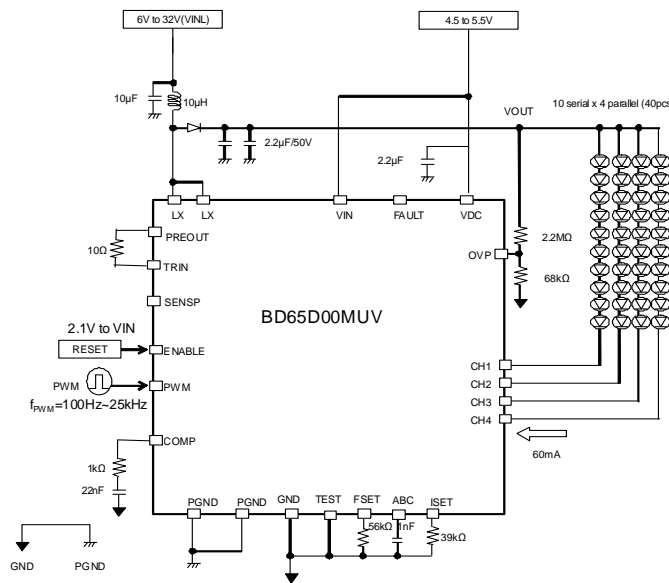

Figure 50. Application at the time of power supply isolation

## PCB Layout

In order to make the most of the performance of this IC, its PCB layout is very important. Characteristics such as efficiency and ripple and the likes change greatly with layout patterns, which please note carefully.

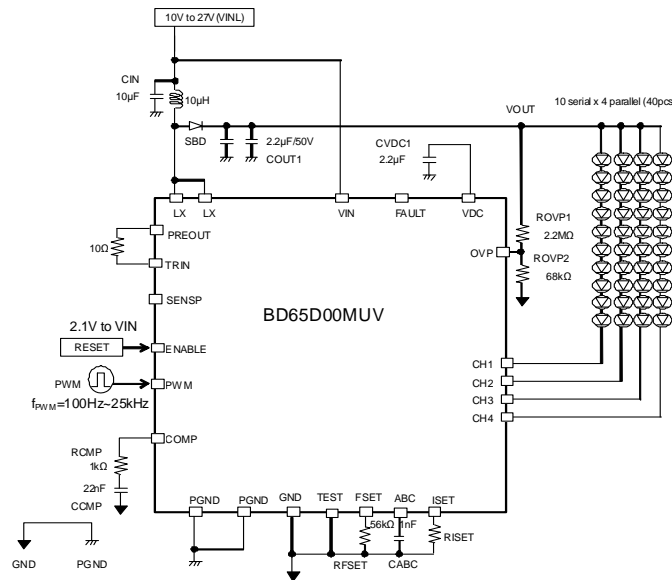

Figure 51. Schematic

<Coil's Input bypass capacitor CIN (10µF)>

Put input bypass capacitor CIN (10µF) as close as possible between coil1 and PGND pin.

<Smoothing capacitor CVDC1(2.2µF) of the regulator>

Connect smoothing capacitor CVDC1(2.2µF) as close as possible between VDC pin and GND.

<Schottky barrier diode SBD>

Connect schottky barrier diode SBD as close as possible between coil1 and LX pin.

<Output capacitor COUT1>

Connect output capacitor COUT1 between cathode of SBD and PGND.

Make both PGND sides of CVIN and COUT1 as close as possible.

<LED current setting resistor RASET(39kΩ)>>

Connect LED current setting resistor RASET(39kΩ) as close as possible between ISET pin and GND.

There is possibility to oscillate when capacity is added to ISET terminal, so pay attention that capacity isn't added.

<Analog dimming pin smoothing capacitor CABC (1nF)>

Put analog dimming pin smoothing capacitor CABC (1nF) close to ABC pin and do not extend the wiring to prevent noise increasing and also LED current waving.

<Frequency setting resistor(56KΩ)>

Put frequency setting resistor(56KΩ) as close as possible between FSET pin and GND.

<Over voltage limit setting resistor ROVP1(2.2MΩ) and ROVP2(68KΩ)>

Put over voltage limit setting resistor ROVP1(2.2MΩ) and ROVP2(68KΩ) as close as possible to

OVP pin and do not extend the wiring to prevent noise increasing and also detecting over voltage protection in error.

<GMAMP setting resistor RCMP(1kΩ) and CCMP(1nF) for phase compensation >

Put GMAMP setting resistor RCMP(1KΩ) and CCMP(22nF) as close as possible to COMP pin and do not extend the wiring to prevent noise increasing and also oscillating.

<GND and PGND connection>

GND is analog ground, and PGND is power ground. PGND might cause a lot of noise due to the coil current of PGND.

Try to connect with analog ground, after smoothing with input bypath capacitor CVIN and output capacitor COUT1.

<Heat radiation of back side PAD>

PAD is used for improving the efficiency of IC heat radiation. Solder PAD to GND pin (analog ground).

Moreover, connect ground plane of board using via as shown in the patterns of next page.

The efficiency of heat radiation improves according to the area of ground plane.

<Others>

When those pins are not connected directly near the chip, influence is give to the performance of BD65D00MUV, and limit the current drive performance. As for the wire to the inductor, make its resistance component small so as to reduce electric power consumption and increase the entire efficiency.

Recommended PCB Layout

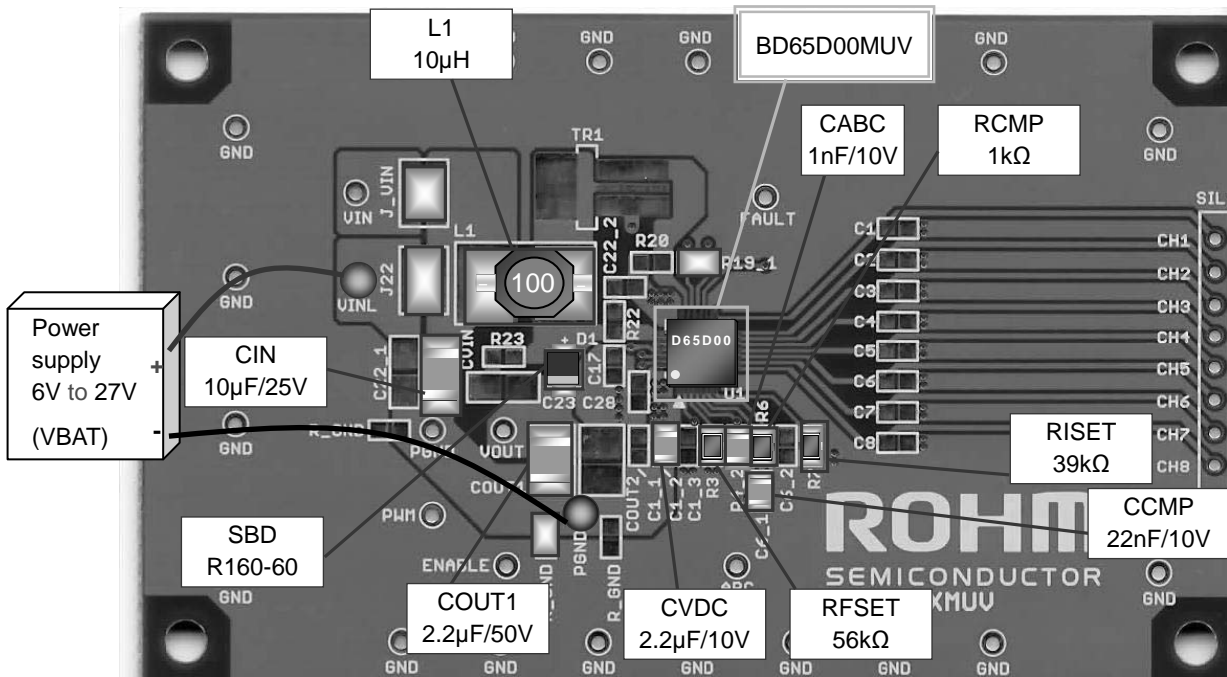

Figure 52. TOP

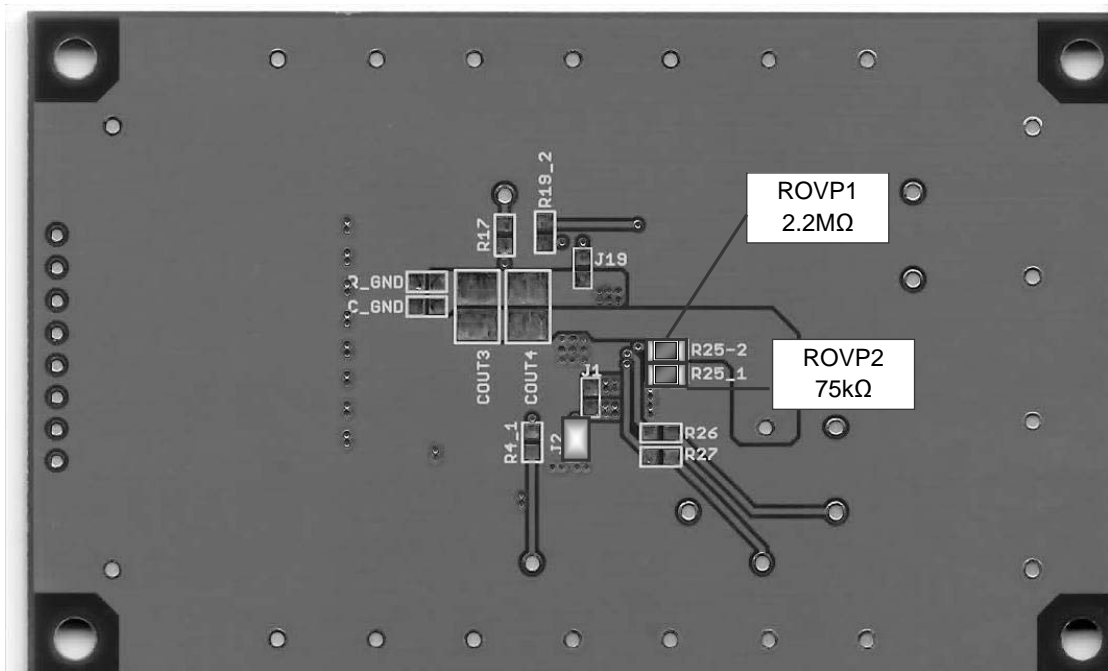

Figure 53. BOTTOM

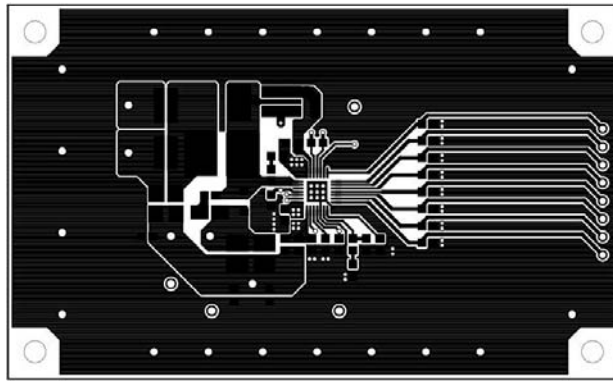

Figure 54. Top Copper trace layer

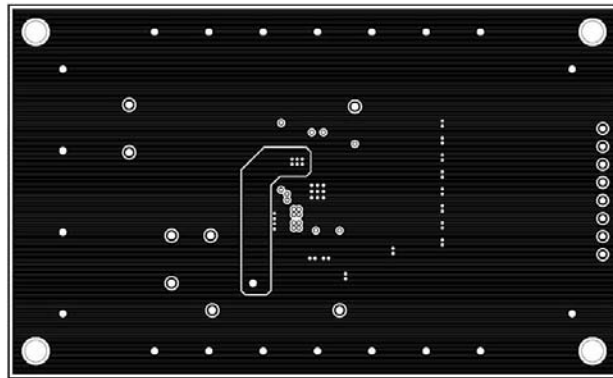

Figure 55. Middle1 Copper trace layer

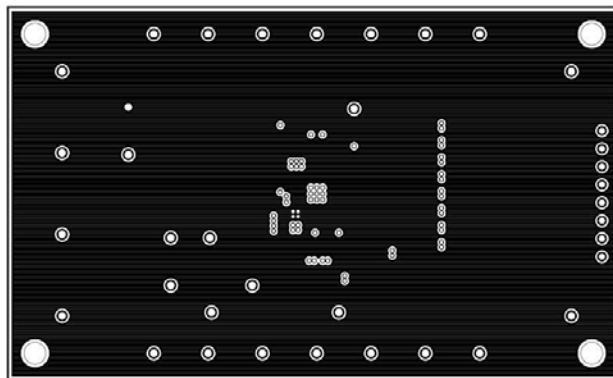

Figure 56. Middle2 Copper trace layer

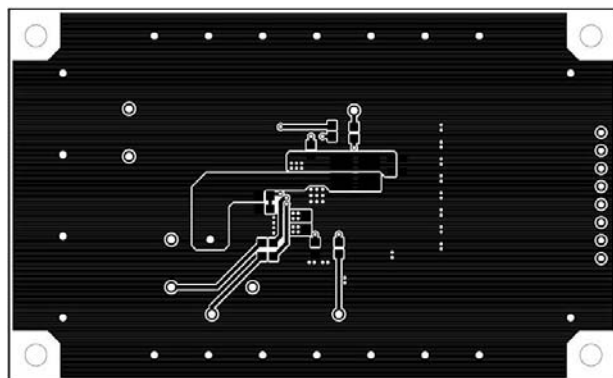

Figure 57. Bottom Copper trace layer

### Selection of External Parts

Recommended external parts are as shown below.

When to use other parts than these, select the following equivalent parts.

#### •Coil

Value	Manufacturer	Product number	Size (mm)			DC current (mA)	DCR (Ω)
			L	W	H (Max.)		
4.7μH	TDK	LTF5022T-4R7N2R0-LC	5.0	5.2	2.2	2000	0.073
4.7μH	TOKO	A915AY-4R7M	5.2	5.2	3.0	1870	0.045
4.7μH	TOKO	B1015AS-4R7M	8.4	8.3	4.0	3300	0.038
10μH	TDK	LTF5022T-100M1R4-LC	5.0	5.2	2.2	1400	0.140
10μH	TOKO	A915AY-100M	5.2	5.2	3.0	1400	0.140
10μH	TOKO	B1047AS-100M	7.6	7.6	5.0	2700	0.053

#### •Capacitor

Value	Pressure	Manufacturer	Product number	Size		
				L	W	H
10μF	25V	MURATA	GRM31CB31E106KA75	3.2	1.6	1.6
4.7μF	25V	MURATA	GRM319R61E475K	3.2	1.6	0.85±0.1
2.2μF	50V	TDK	C3225JB1H225K	3.2	2.5	2.0±0.2
2.2μF	50V	MURATA	GRM31CB31H225K	3.2	1.6	1.6
2.2μF	50V	Panasonic	ECJHVB1H225K	3.2	1.6	0.85
2.2μF	10V	MURATA	GRM188B31A225K	1.6	0.8	0.8
0.1μF	50V	MURATA	GRM188B31H104K	1.6	0.8	0.8
0.1μF	10V	MURATA	GRM188B31A104K	1.6	0.8	0.8
0.022μF	10V	MURATA	GRM155B31H223K	1.0	0.5	0.5
470pF	50V	MURATA	GRM155B11H471K	1.0	0.5	0.5

#### •Resistor

Value	Tolerance	Manufacturer	Product number	Size (mm)		
				L	W	H
2.2MΩ	±1.0%	ROHM	MCR03PZPZFX2204	1.6	0.8	0.45
91kΩ	±0.5%	ROHM	MCR03PZPZD9102	1.6	0.8	0.45
75kΩ	±0.5%	ROHM	MCR03PZPZD7502	1.6	0.8	0.45
68kΩ	±0.5%	ROHM	MCR03PZPZD6802	1.6	0.8	0.45
56kΩ	±0.5%	ROHM	MCR03PZPZD5602	1.6	0.8	0.45
36kΩ	±0.5%	ROHM	MCR03PZPZD3602	1.6	0.8	0.45
10kΩ	±1.0%	ROHM	MCR03PZPZF103	1.6	0.8	0.45
1kΩ	±0.5%	ROHM	MCR03PZPZD1002	1.6	0.8	0.45
330Ω	±0.5%	ROHM	MCR03PZPZD3300	1.6	0.8	0.45

#### •SBD

Pressure	Manufacturer	Product number	Size (mm)		
			L	W	H (Max.)
60V	ROHM	RB160M-60	3.5	1.6	0.8

#### MOS FET Nch

Pressure	Manufacturer	Product number	Size (mm)			I <sub>D</sub> (A)	Drive voltage (V)
			L	W	H (Max.)		
45V	ROHM	RTR020N05	2.8	2.9	1.0	2	2.5
45V	ROHM	RTR030N05	2.8	2.9	1.0	3	2.5

The coil is the part that is most influential to efficiency. Select the coil whose direct current resistor (DCR) is small and current - inductance characteristic is excellent. BD65D00 is designed for the inductance value of 10μH. Don't use the inductance value less than 3.3μH. Select a capacitor of ceramic type with excellent frequency and temperature characteristics. Further, select Capacitor to be used with small direct current resistance.

### About Heat Loss

In heat design, operate the DC/DC converter in the following condition.

(The following temperature is a guarantee temperature, so consider the margin.)

1. Ambient temperature Ta must be less than 85 .
2. The loss of IC must be less than dissipation Pd.

**Application Example**

Nch FET using internal/external

This IC can be changed with the internal/external NchFET for switching to suit your application.

It is possible when the heat dispersion of a package of cases, such as light, LED current is used, and we use the external NchFET.

**1. External FET application**

LED current: 60mA (ISET = 39kΩ)

LED: 15 LEDs in series, 4 strings in parallel

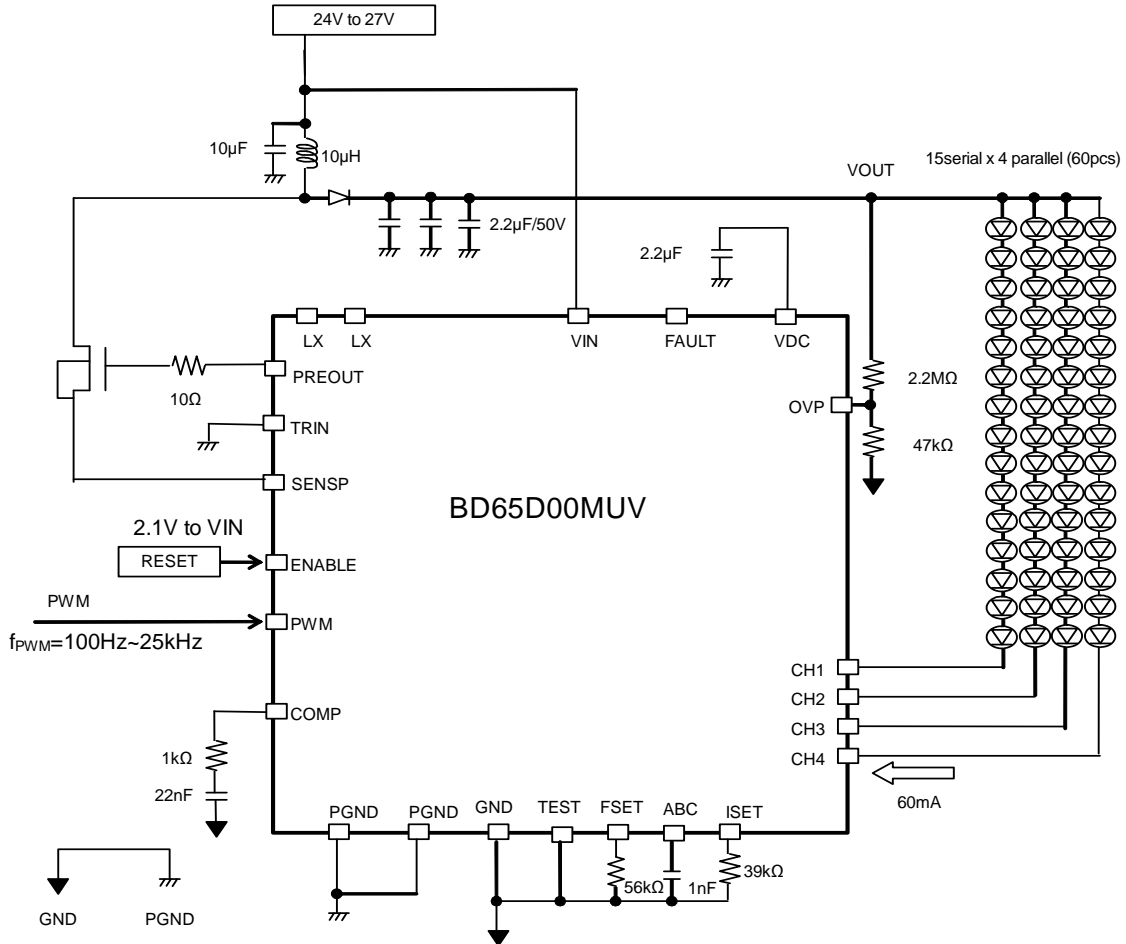

Figure 58. Application example of external FET

2. Analog Dimming and monitoring FAULT terminal  
 LED current: 60mA (ISET = 39kΩ)  
 LED: 10 LEDs in series, 4 strings in parallel

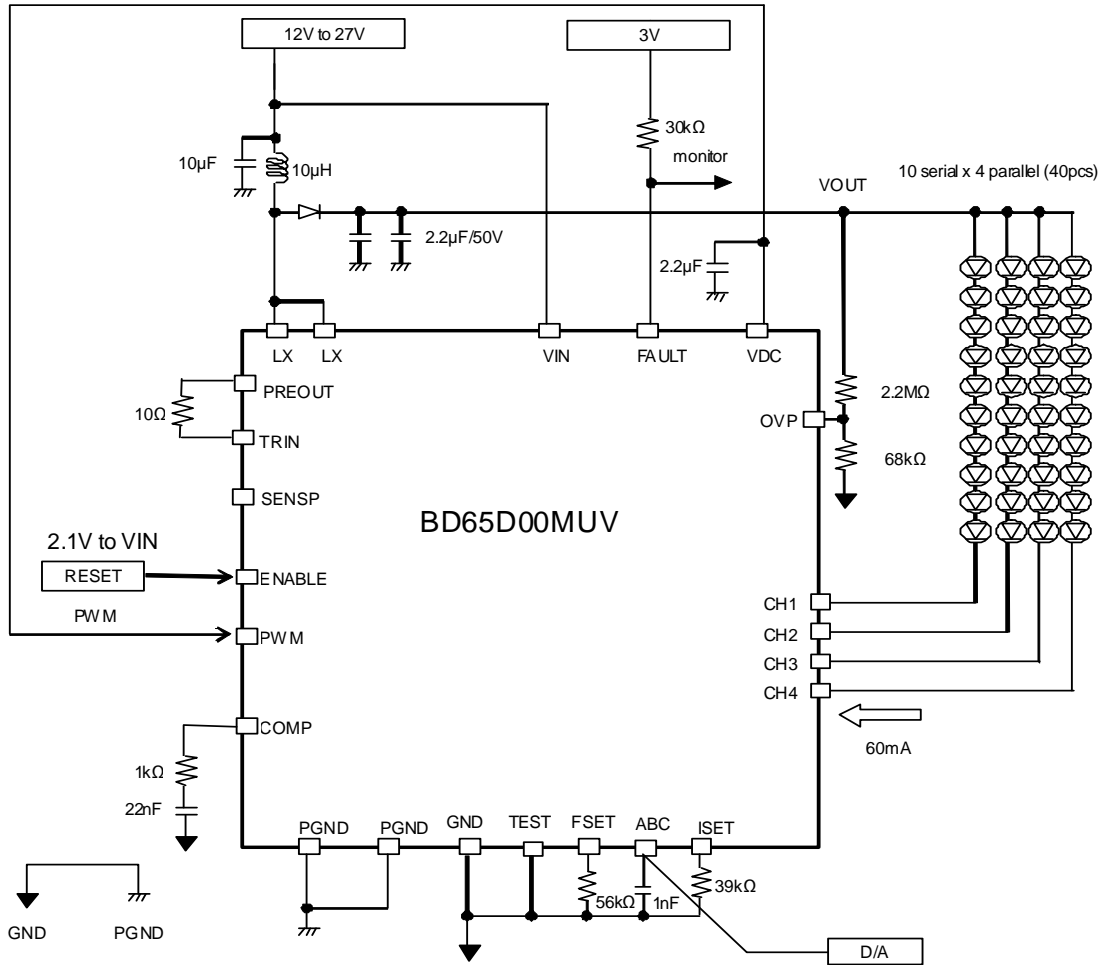

Figure 59. Application example of Analog dimming

## Operational Notes

- (1) Absolute Maximum Ratings  
An excess in the absolute maximum ratings, such as supply voltage (VIN), temperature range of operating conditions (Topr), etc., can break down devices, thus making impossible to identify breaking mode such as a short circuit or an open circuit. If any special mode exceeding the absolute maximum ratings is assumed, consideration should be given to take physical safety measures including the use of fuses, etc.
- (2) Operating conditions  
These conditions represent a range within which characteristics can be provided approximately as expected. The electrical characteristics are guaranteed under the conditions of each parameter.
- (3) Reverse connection of power supply connector  
The reverse connection of power supply connector can break down ICs. Take protective measures against the breakdown due to the reverse connection, such as mounting an external diode between the power supply and the IC's power supply terminal.
- (4) Power supply line  
Design PCB pattern to provide low impedance for the wiring between the power supply and the GND lines. Furthermore, for all power supply terminals to ICs, mount a capacitor between the power supply and the GND terminal. At the same time, in order to use an electrolytic capacitor, thoroughly check to be sure the characteristics of the capacitor to be used present no problem including the occurrence of capacity dropout at a low temperature, thus determining the constant.
- (5) GND voltage  
Make setting of the potential of the GND terminal so that it will be maintained at the minimum in any operating state. Furthermore, check to be sure no terminals are at a potential lower than the GND voltage including an actual electric transient.
- (6) Short circuit between terminals and erroneous mounting  
In order to mount ICs on a set PCB, pay thorough attention to the direction and offset of the ICs. Erroneous mounting can break down the ICs. Furthermore, if a short circuit occurs due to foreign matters entering between terminals or between the terminal and the power supply or the GND terminal, the ICs can break down.
- (7) Operation in strong electromagnetic field  
Be noted that using ICs in the strong electromagnetic field can malfunction them.
- (8) Inspection with set PCB  
On the inspection with the set PCB, if a capacitor is connected to a low-impedance IC terminal, the IC can suffer stress. Therefore, be sure to discharge from the set PCB by each process. Furthermore, in order to mount or dismount the set PCB to/from the jig for the inspection process, be sure to turn OFF the power supply and then mount the set PCB to the jig. After the completion of the inspection, be sure to turn OFF the power supply and then dismount it from the jig. In addition, for protection against static electricity, establish a ground for the assembly process and pay thorough attention to the transportation and the storage of the set PCB.
- (9) Input terminals  
In terms of the construction of IC, parasitic elements are inevitably formed in relation to potential. The operation of the parasitic element can cause interference with circuit operation, thus resulting in a malfunction and then breakdown of the input terminal. Therefore, pay thorough attention not to handle the input terminals, such as to apply to the input terminals a voltage lower than the GND respectively, so that any parasitic element will operate. Furthermore, do not apply a voltage to the input terminals when no power supply voltage is applied to the IC. In addition, even if the power supply voltage is applied, apply to the input terminals a voltage lower than the power supply voltage or within the guaranteed value of electrical characteristics.
- (10) Ground wiring pattern  
If small-signal GND and large-current GND are provided, It will be recommended to separate the large-current GND pattern from the small-signal GND pattern and establish a single ground at the reference point of the set PCB so that resistance to the wiring pattern and voltage fluctuations due to a large current will cause no fluctuations in voltages of the small-signal GND. Pay attention not to cause fluctuations in the GND wiring pattern of external parts as well.
- (11) External capacitor  
In order to use a ceramic capacitor as the external capacitor, determine the constant with consideration given to a degradation in the nominal capacitance due to DC bias and changes in the capacitance due to temperature, etc.
- (12) Thermal shutdown circuit (TSD)  
When junction temperatures become 175 (typ.) or higher, the thermal shutdown circuit operates and turns a switch OFF. The thermal shutdown circuit, which is aimed at isolating the LSI from thermal runaway as much as possible, is not aimed at the protection or guarantee of the LSI. Therefore, do not continuously use the LSI with this circuit operating or use the LSI assuming its operation.
- (13) Thermal design  
Perform thermal design in which there are adequate margins by taking into account the permissible dissipation (Pd) in actual states of use.
- (14) Selection of coil  
Select the low DCR inductors to decrease power loss for DC/DC converter.

Status of this document

The Japanese version of this document is formal specification. A customer may use this translation version only for a reference to help reading the formal version.

If there are any differences in translation version of this document formal version takes priority.

Ordering Information

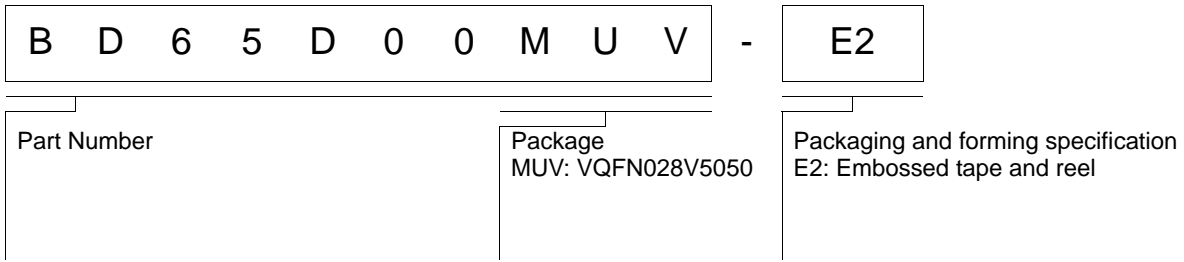

Marking Diagram

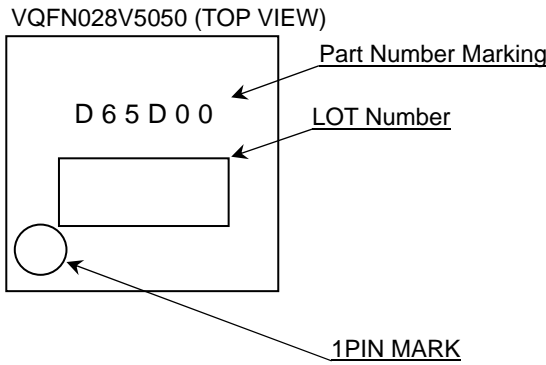

Figure 60. Marking Diagram

Physical Dimension Tape and Reel Information

VQFN028V5050

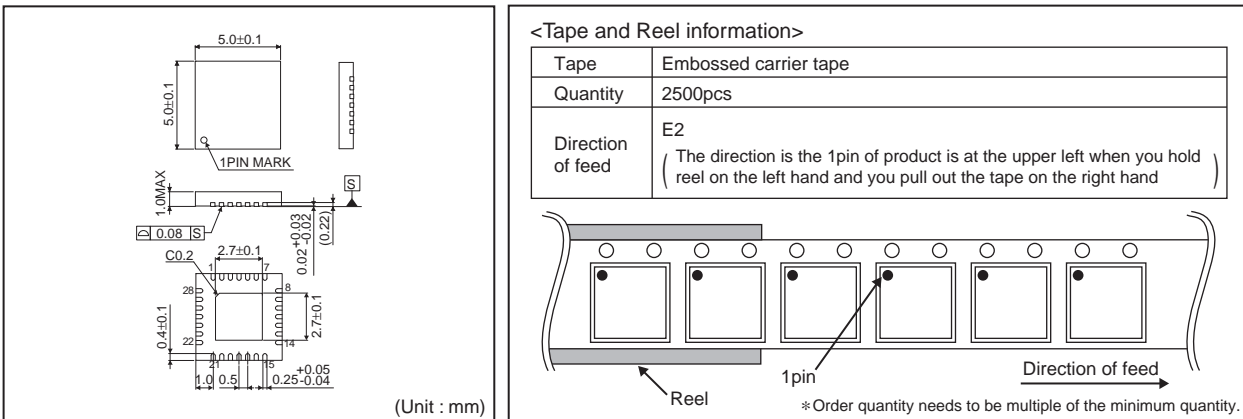

Figure 61. VQFN028V5050

**Revision History**

Date	Revision	Changes
07.Dec.2012	001	New Release

# Notice

## Precaution on using ROHM Products

- Our Products are designed and manufactured for application in ordinary electronic equipments (such as AV equipment, OA equipment, telecommunication equipment, home electronic appliances, amusement equipment, etc.). If you intend to use our Products in devices requiring extremely high reliability (such as medical equipment <sup>(Note 1)</sup>, transport equipment, traffic equipment, aircraft/spacecraft, nuclear power controllers, fuel controllers, car equipment including car accessories, safety devices, etc.) and whose malfunction or failure may cause loss of human life, bodily injury or serious damage to property ("Specific Applications"), please consult with the ROHM sales representative in advance. Unless otherwise agreed in writing by ROHM in advance, ROHM shall not be in any way responsible or liable for any damages, expenses or losses incurred by you or third parties arising from the use of any ROHM's Products for Specific Applications.

(Note1) Medical Equipment Classification of the Specific Applications

JAPAN	USA	EU	CHINA
CLASS III	CLASS III	CLASS II b	CLASS III
CLASS IV		CLASS III	

- ROHM designs and manufactures its Products subject to strict quality control system. However, semiconductor products can fail or malfunction at a certain rate. Please be sure to implement, at your own responsibilities, adequate safety measures including but not limited to fail-safe design against the physical injury, damage to any property, which a failure or malfunction of our Products may cause. The following are examples of safety measures:
  - Installation of protection circuits or other protective devices to improve system safety
  - Installation of redundant circuits to reduce the impact of single or multiple circuit failure
- Our Products are designed and manufactured for use under standard conditions and not under any special or extraordinary environments or conditions, as exemplified below. Accordingly, ROHM shall not be in any way responsible or liable for any damages, expenses or losses arising from the use of any ROHM's Products under any special or extraordinary environments or conditions. If you intend to use our Products under any special or extraordinary environments or conditions (as exemplified below), your independent verification and confirmation of product performance, reliability, etc. prior to use, must be necessary:
  - Use of our Products in any types of liquid, including water, oils, chemicals, and organic solvents
  - Use of our Products outdoors or in places where the Products are exposed to direct sunlight or dust
  - Use of our Products in places where the Products are exposed to sea wind or corrosive gases, including Cl<sub>2</sub>, H<sub>2</sub>S, NH<sub>3</sub>, SO<sub>2</sub>, and NO<sub>2</sub>
  - Use of our Products in places where the Products are exposed to static electricity or electromagnetic waves
  - Use of our Products in proximity to heat-producing components, plastic cords, or other flammable items
  - Sealing or coating our Products with resin or other coating materials
  - Use of our Products without cleaning residue of flux (even if you use no-clean type fluxes, cleaning residue of flux is recommended); or Washing our Products by using water or water-soluble cleaning agents for cleaning residue after soldering
  - Use of the Products in places subject to dew condensation
- The Products are not subject to radiation-proof design.
- Please verify and confirm characteristics of the final or mounted products in using the Products.
- In particular, if a transient load (a large amount of load applied in a short period of time, such as pulse. is applied, confirmation of performance characteristics after on-board mounting is strongly recommended. Avoid applying power exceeding normal rated power; exceeding the power rating under steady-state loading condition may negatively affect product performance and reliability.
- De-rate Power Dissipation (Pd) depending on Ambient temperature (Ta). When used in sealed area, confirm the actual ambient temperature.
- Confirm that operation temperature is within the specified range described in the product specification.
- ROHM shall not be in any way responsible or liable for failure induced under deviant condition from what is defined in this document.

## Precaution for Mounting / Circuit board design

- When a highly active halogenous (chlorine, bromine, etc.) flux is used, the residue of flux may negatively affect product performance and reliability.
- In principle, the reflow soldering method must be used; if flow soldering method is preferred, please consult with the ROHM representative in advance.

For details, please refer to ROHM Mounting specification

**Precautions Regarding Application Examples and External Circuits**

1. If change is made to the constant of an external circuit, please allow a sufficient margin considering variations of the characteristics of the Products and external components, including transient characteristics, as well as static characteristics.
2. You agree that application notes, reference designs, and associated data and information contained in this document are presented only as guidance for Products use. Therefore, in case you use such information, you are solely responsible for it and you must exercise your own independent verification and judgment in the use of such information contained in this document. ROHM shall not be in any way responsible or liable for any damages, expenses or losses incurred by you or third parties arising from the use of such information.

**Precaution for Electrostatic**

This Product is electrostatic sensitive product, which may be damaged due to electrostatic discharge. Please take proper caution in your manufacturing process and storage so that voltage exceeding the Products maximum rating will not be applied to Products. Please take special care under dry condition (e.g. Grounding of human body / equipment / solder iron, isolation from charged objects, setting of Ionizer, friction prevention and temperature / humidity control).

**Precaution for Storage / Transportation**

1. Product performance and soldered connections may deteriorate if the Products are stored in the places where:
  - [a] the Products are exposed to sea winds or corrosive gases, including Cl<sub>2</sub>, H<sub>2</sub>S, NH<sub>3</sub>, SO<sub>2</sub>, and NO<sub>2</sub>
  - [b] the temperature or humidity exceeds those recommended by ROHM
  - [c] the Products are exposed to direct sunshine or condensation
  - [d] the Products are exposed to high Electrostatic
2. Even under ROHM recommended storage condition, solderability of products out of recommended storage time period may be degraded. It is strongly recommended to confirm solderability before using Products of which storage time is exceeding the recommended storage time period.
3. Store / transport cartons in the correct direction, which is indicated on a carton with a symbol. Otherwise bent leads may occur due to excessive stress applied when dropping of a carton.
4. Use Products within the specified time after opening a humidity barrier bag. Baking is required before using Products of which storage time is exceeding the recommended storage time period.

**Precaution for Product Label**

QR code printed on ROHM Products label is for ROHM's internal use only.

**Precaution for Disposition**

When disposing Products please dispose them properly using an authorized industry waste company.

**Precaution for Foreign Exchange and Foreign Trade act**

Since our Products might fall under controlled goods prescribed by the applicable foreign exchange and foreign trade act, please consult with ROHM representative in case of export.

**Precaution Regarding Intellectual Property Rights**

1. All information and data including but not limited to application example contained in this document is for reference only. ROHM does not warrant that foregoing information or data will not infringe any intellectual property rights or any other rights of any third party regarding such information or data. ROHM shall not be in any way responsible or liable for infringement of any intellectual property rights or other damages arising from use of such information or data.:
2. No license, expressly or implied, is granted hereby under any intellectual property rights or other rights of ROHM or any third parties with respect to the information contained in this document.

**Other Precaution**



1. This document may not be reprinted or reproduced, in whole or in part, without prior written consent of ROHM.
2. The Products may not be disassembled, converted, modified, reproduced or otherwise changed without prior written consent of ROHM.
3. In no event shall you use in any way whatsoever the Products and the related technical information contained in the Products or this document for any military purposes, including but not limited to, the development of mass-destruction weapons.
4. The proper names of companies or products described in this document are trademarks or registered trademarks of ROHM, its affiliated companies or third parties.

**General Precaution**

1. Before you use our Products, you are requested to carefully read this document and fully understand its contents. ROHM shall not be in any way responsible or liable for failure, malfunction or accident arising from the use of any ROHM's Products against warning, caution or note contained in this document.
2. All information contained in this document is current as of the issuing date and subject to change without any prior notice. Before purchasing or using ROHM's Products, please confirm the latest information with a ROHM sales representative.
3. The information contained in this document is provided on an "as is" basis and ROHM does not warrant that all information contained in this document is accurate and/or error-free. ROHM shall not be in any way responsible or liable for any damages, expenses or losses incurred by you or third parties resulting from inaccuracy or errors of or concerning such information.

## Looking for pricing, stock, or lifecycle information?

Click below to explore more details on WIN SOURCE:

-  [View BD65D00MUV-E2 on WIN SOURCE](#)
-  [Rohm Semiconductor](#) Information

## Optimize Your Supply Chain with WIN SOURCE Solutions

-  Global Sourcing Solution
-  Obsolete Management
-  Cost Control Management
-  Shortage Management
-  Alternative Solution
-  Excess Inventory Management