

# 6-Channel Charge Pump White LED Driver with 64 Dimming Steps and I<sup>2</sup>C Compatible Interface

## BD2606MVV

### General Description

BD2606MVV is a multi-level brightness control white LED driver that not only ensures efficient boost by automatically changing the boost rate but also works as a constant current driver with 64 steps, so that the driving current can be adjusted finely. This IC is best suited to turn ON white LEDs that require high-accuracy LED brightness control.

### Features

- 6-Ch Parallel LED Driver
- 64-Step LED Current Adjust Function
- Inter-LED Relative Current Accuracy: 3% or less
- LED Individual Lighting/Dimming Control via I<sup>2</sup>C BUS Interface
- Automatic Transition Charge Pump Type DC/DC Converter (x1, x1.5 and x2)
- High Efficiency (90% or More at Maximum)
- Various Protection Functions such as Output Voltage Protection, Over-Current Limiter and Thermal Shutdown Circuit

### Key Specifications

- Power Supply Voltage Range: 2.7V to 5.5V
- Oscillation Frequency: 1.0MHz(Typ)
- Quiescent Current: 0μA(Typ)
- Operating Temperature Range: -30°C to +85°C

### Package

W(Typ) x D(Typ) x H(Max)



SQFN016V4040  
4.00mm x 4.00mm x 1.00mm

### Applications

This driver is applicable for various fields such as mobile phones, portable game machines and white LED products.

### Typical Application Circuit

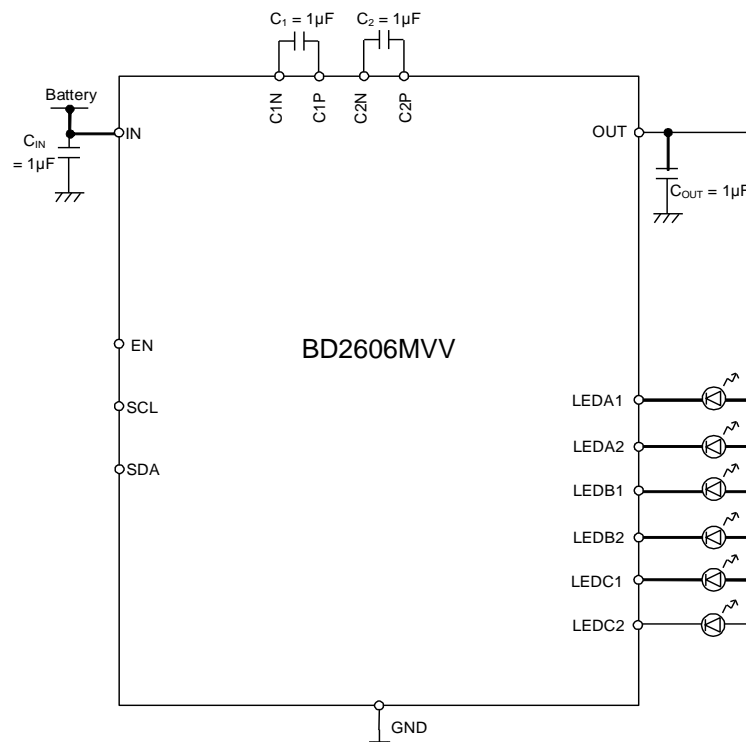

○Product structure : Silicon monolithic integrated circuit ○This product has no designed protection against radioactive rays

## Absolute Maximum Ratings (Ta=25°C)

Parameter	Symbol	Ratings	Unit	Condition
Power Supply Voltage	V <sub>MAX</sub>	7	V	
Operating Temperature Range	Topr	-30 to +85	°C	
Storage Temperature Range	Tstg	-55 to +150	°C	
Power Dissipation	Pd	0.78 (Note 1)	W	

(Note 1) When mounted on a glass epoxy substrate (70mm x 70mm x 1.6mm), derate by 6.2mW/°C for Ta is higher than 25°C.

**Caution:** Operating the IC over the absolute maximum ratings may damage the IC. The damage can either be a short circuit between pins or an open circuit between pins and the internal circuitry. Therefore, it is important to consider circuit protection measures such as adding a fuse, in case the IC is operated over the absolute maximum ratings.

## Recommended Operating Conditions (Ta=-30°C to +85°C)

Parameter	Symbol	Ratings	Unit	Condition
Operating power supply voltage	V <sub>CC</sub>	2.7 to 5.5	V	

Electrical Characteristics (Unless otherwise specified, Ta = 25°C and V<sub>IN</sub> = 3.6V.)

Parameter	Symbol	Limit			Unit	Conditions
		Min	Typ	Max		
Quiescent Current	I <sub>DDQ</sub>	-	0	7	µA	V <sub>EN</sub> =0V, V <sub>IN</sub> =3.6V
Circuit Current 1	I <sub>DD1</sub>	-	1.0	2.6	mA	x1 mode, I <sub>OUT</sub> =0mA, V <sub>IN</sub> =3.6V
[Charge Pump]						
Output Current	I <sub>OUT</sub>	-	-	120	mA	V <sub>OUT</sub> =4.0V, V <sub>IN</sub> =3.6V
Oscillation Frequency	f <sub>OSC</sub>	0.8	1.0	1.2	MHz	Add=0 x 03, D6='0'
[LED Driver]						
LED Current Absolute Precision	I <sub>LED-ERR</sub>	-	-	±6.5	%	I <sub>LED</sub> = 16.5mA (LEDx_CNT=0x20), LED pin voltage 1.0V
LED Current Relative Precision	I <sub>LED-10-LED</sub>	-	0.5	±3.75 (Note 2)	%	I <sub>LED</sub> = 16.5mA (LEDx_CNT=0x20), LED pin voltage 1.0V
LED Control Voltage	V <sub>LED</sub>	-	0.2	0.25	V	I <sub>LEDA1</sub> , I <sub>LEDA2</sub> , I <sub>LEDB1</sub> , I <sub>LEDB2</sub> , I <sub>LEDC1</sub> , I <sub>LEDC2</sub>
[Logic Interface]						
Input 'L' Voltage	V <sub>IL</sub>	-	-	0.4	V	EN, SCL, SDA
Input 'H' Voltage	V <sub>IH</sub>	1.6	-	-	V	EN, SCL, SDA
Input 'H' Current	I <sub>IH</sub>	-	-	10	µA	EN, SCL, SDA=V <sub>IN</sub>
Input 'L' Current	I <sub>IL</sub>	-10	-	-	µA	EN, SCL, SDA=GND
'L' Level SDA Output	V <sub>OL</sub>	-	-	0.4	V	SDA, 3mA source
		-	-	0.6	V	SDA, 6mA source
[I <sup>2</sup> C BUS Interface (Standard Mode)]						
SCL Clock Frequency	f <sub>SCLC</sub>	0	-	100	kHz	
SCL Low Duration	t <sub>LOW</sub>	4.7	-	-	µs	
SCL High Duration	t <sub>HIGH</sub>	4.0	-	-	µs	
Data Hold Time	t <sub>HD;DAT</sub>	0	-	3.45	µs	
Data Setup Time	t <sub>SU;DAT</sub>	250	-	-	ns	
Setup Time – Restart Condition	t <sub>SU;STA</sub>	4.7	-	-	µs	
Hold Time – Restart Condition	t <sub>HD;STA</sub>	4.0	-	-	µs	
Setup Time – Stop Condition	t <sub>SU;STO</sub>	4.0	-	-	µs	
Bus Free Time Between Start and Stop	t <sub>BUF</sub>	4.7	-	-	µs	
[I <sup>2</sup> C BUS Interface (Fast Mode)]						
SCL Clock Frequency	f <sub>SCL</sub>	0	-	400	kHz	
SCL Low Duration	t <sub>LOW</sub>	1.3	-	-	µs	
SCL High Duration	t <sub>HIGH</sub>	0.6	-	-	µs	
Data Hold Time	t <sub>HD;DAT</sub>	0	-	0.9	µs	
Data Setup Time	t <sub>SU;DAT</sub>	100	-	-	ns	
Setup Time – Restart Condition	t <sub>SU;STA</sub>	0.6	-	-	µs	
Hold Time – Restart Condition	t <sub>HD;STA</sub>	0.6	-	-	µs	
Setup Time – Stop Condition	t <sub>SU;STO</sub>	0.6	-	-	µs	
Bus Free Time Between Start and Stop	t <sub>BUF</sub>	1.3	-	-	µs	
Interface Startup Time	t <sub>EN</sub>	-	-	350	µs	Bus startup time (after EN='H')

(Note 2) The following expression is used for calculation:

$$I_{LED-match} = \frac{(I_{MAX} - I_{MIN})}{(I_{MAX} + I_{MIN})} \times 100$$

I<sub>MAX</sub> = Current value in a channel with the maximum current value among all channels

I<sub>MIN</sub> = Current value in a channel with the minimum current value among all channels

Pin Description

Pin Number	Pin Name	In/Out	Function	Pin Number	Pin Name	In/Out	Function
1	LEDA1	Out	LED current driver output	9	C2N	In/Out	Flying capacitor pin negative (-) side
2	SDA	In	I <sup>2</sup> C BUS control pin	10	C2P	In/Out	Flying capacitor pin positive (+) side
3	SCL	In	I <sup>2</sup> C BUS control pin	11	GND	-	GND
4	EN	In	ON/OFF control	12	LEDC2	Out	LED current driver output
5	OUT	Out	Charge pump output	13	LEDC1	Out	LED current driver output
6	IN	-	Power supply	14	LEDB2	Out	LED current driver output
7	C1N	In/Out	Flying capacitor pin negative (-) side	15	LEDB1	Out	LED current driver output
8	C1P	In/Out	Flying capacitor pin positive (+) side	16	LEDA2	Out	LED current driver output
-	Thermal PAD	-	Heat radiation PAD of back side. Connect to GND	-	-	-	-

Block Diagram

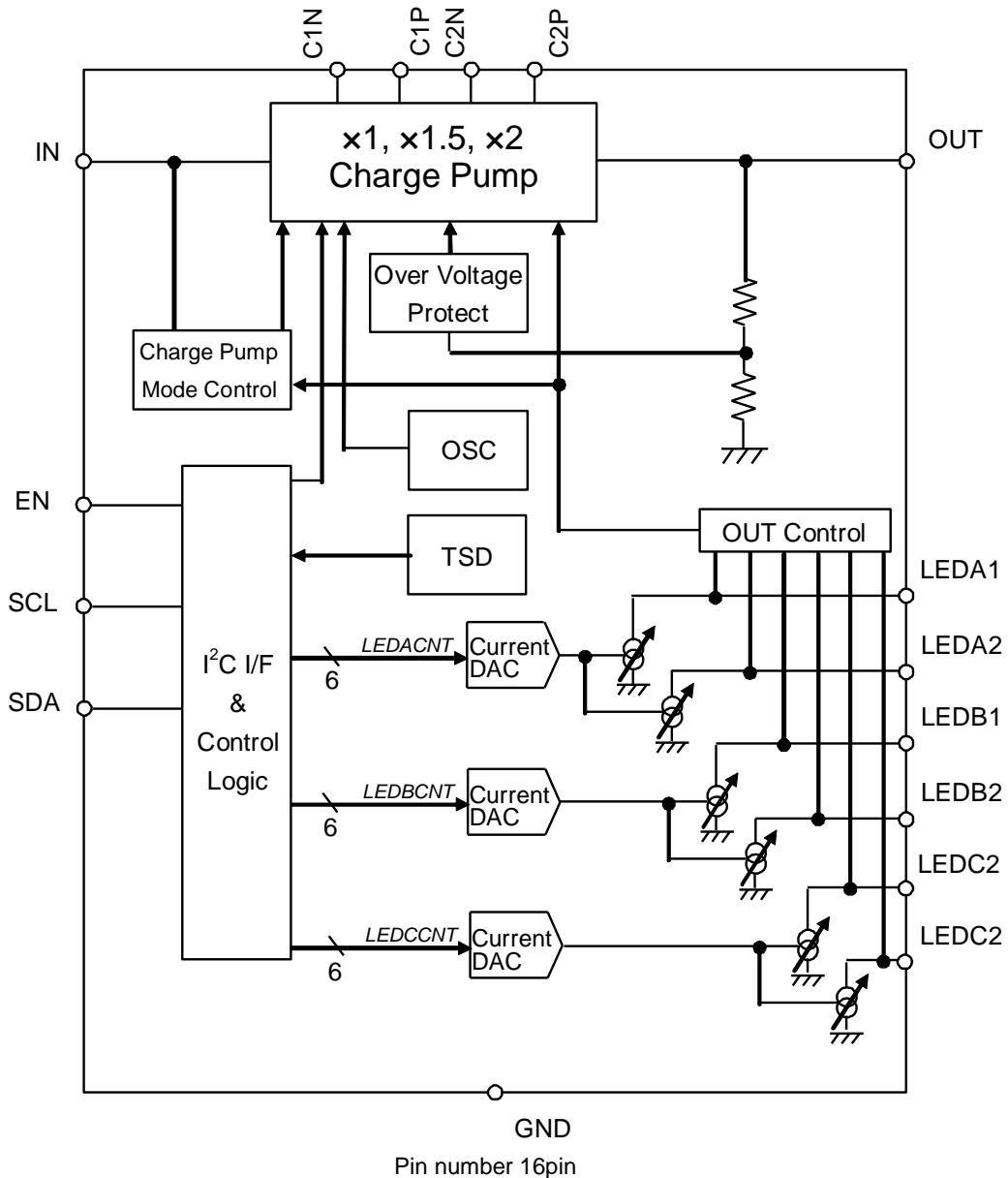

Typical Performance Curves

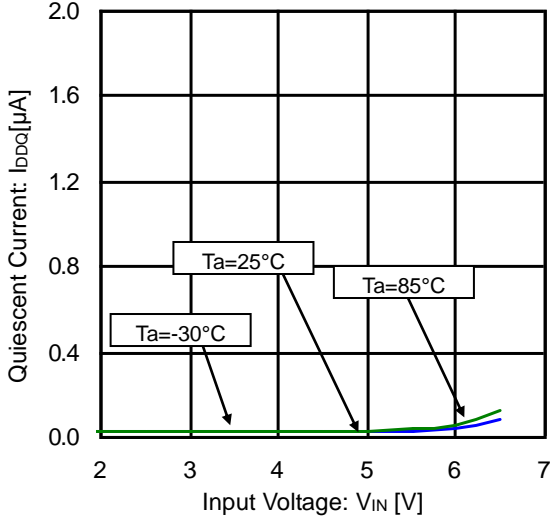

Figure 1. Quiescent Current vs Input Voltage (Standby)

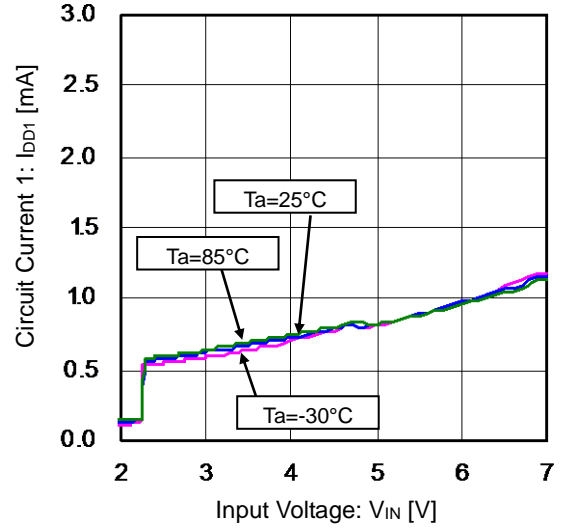

Figure 2. Circuit Current 1 vs Input Voltage (Operation in x1.0 Mode)

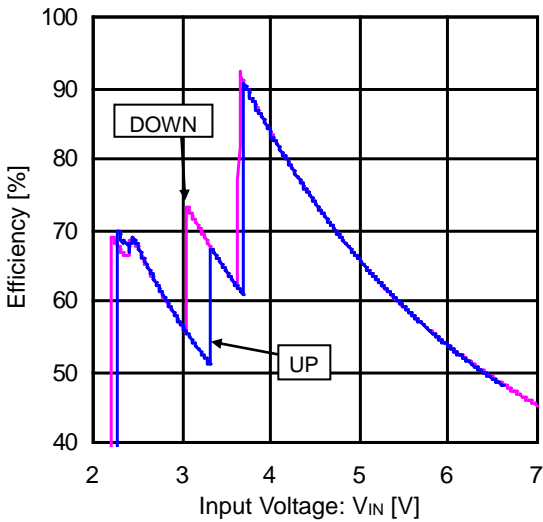

Figure 3. Efficiency Hysteresis vs Input Voltage (13mA x 6 Lights)

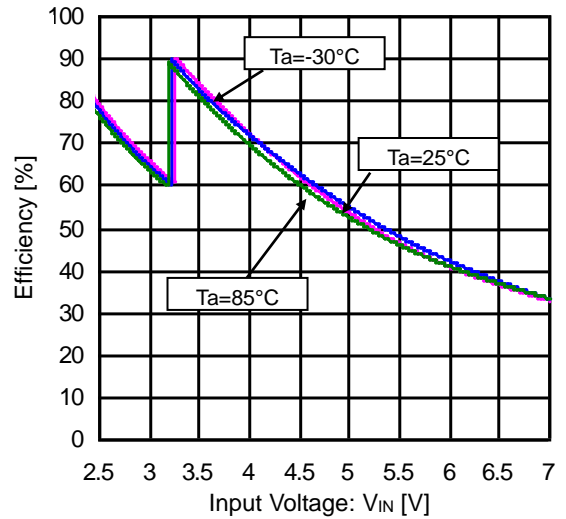

Figure 4. Efficiency vs Input Voltage (3.5mA x 6 Lights)

Typical Performance Curves - continued

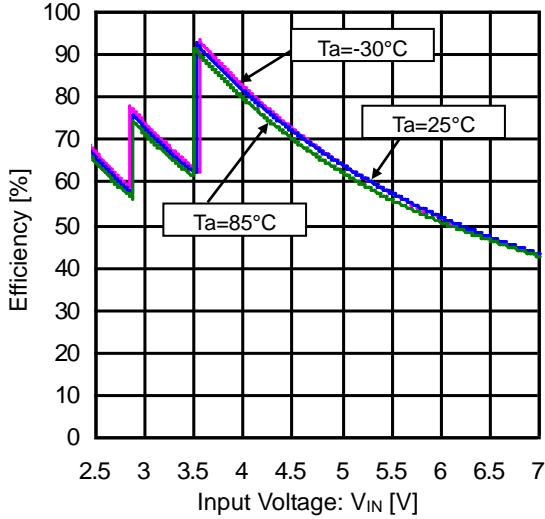

Figure 5. Efficiency vs Input Voltage (10mA x 6 Lights)

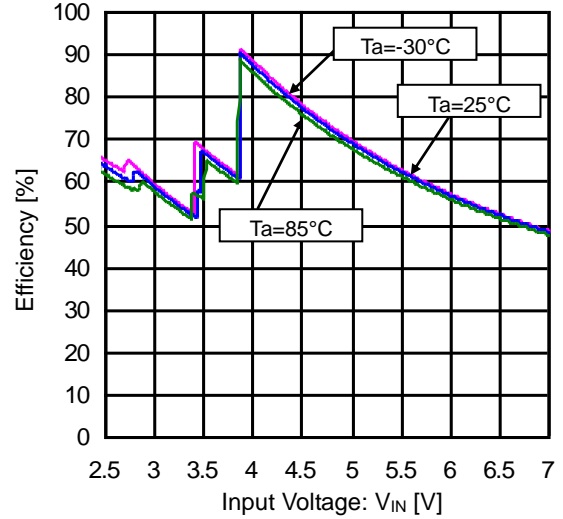

Figure 6. Efficiency vs Input Voltage (20mA x 6 Lights)

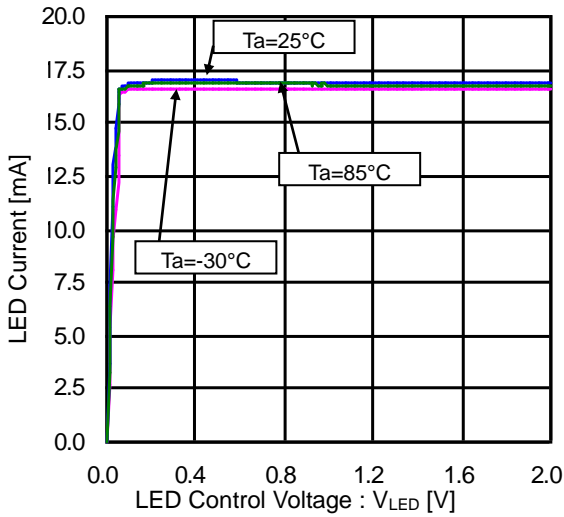

Figure 7. LED Current Characteristics vs LED Control Voltage (LED Current 16.5mA)

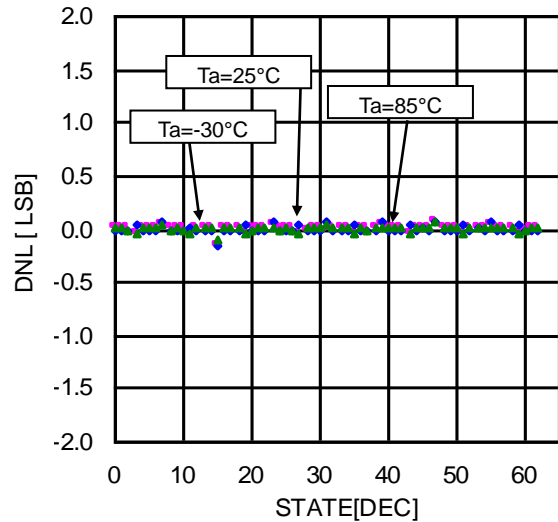

Figure 8. LED Current Characteristics (Differential Linearity Error)

Typical Performance Curves - continued

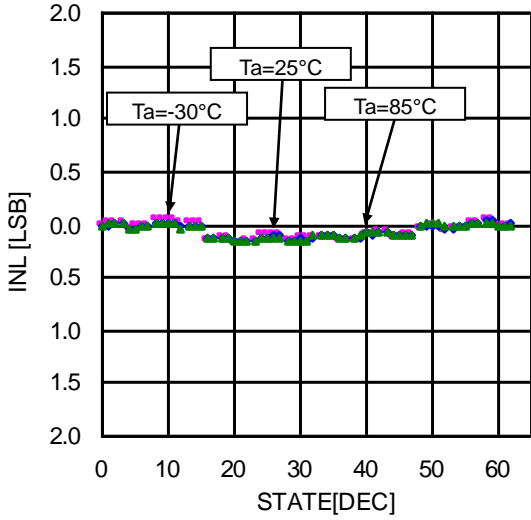

Figure 9. LED Current Characteristics (Integral Linearity Error)

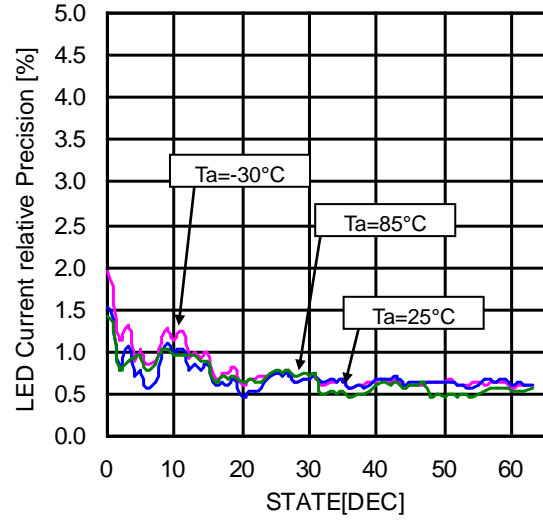

Figure 10. LED Current Matching

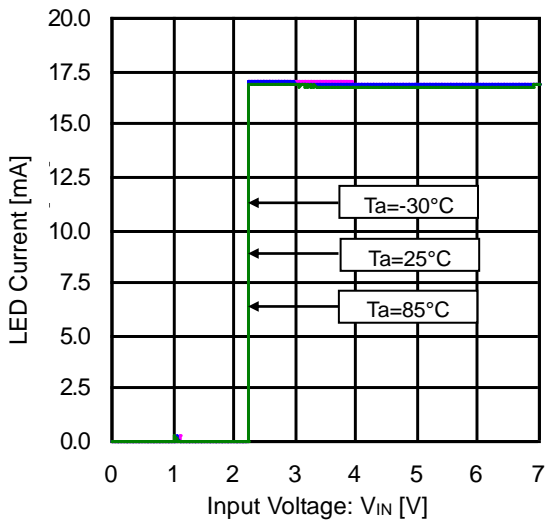

Figure 11. LED Current vs Input Voltage (LED Current 16.5mA)

Application Information

1. Description of Operations

- (1) LED Driver
  - (a) I<sup>2</sup>C BUS Interface

BD2606MVV can control the LED ON/OFF, brightness and charge pump switching frequency by writing to the register via the I<sup>2</sup>C BUS interface. Control by the I<sup>2</sup>C BUS interface is effective when EN is at 'H' level. When EN is at 'L' level, this LSI is completely shut down and the control and associated functions via the I<sup>2</sup>C BUS interface are all stopped.

As shown in Figure 12 below, the I<sup>2</sup>C BUS interface of BD2606MVV operates using the V<sub>EN</sub> voltage (buffering the EN pin voltage) as supply voltage. For this reason, it is desirable that the 'H' voltage in the I<sup>2</sup>C BUS interface is equal to the EN pin voltage.

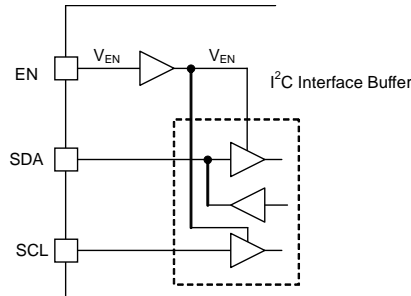

Figure 12. I<sup>2</sup>C BUS Interface Buffer

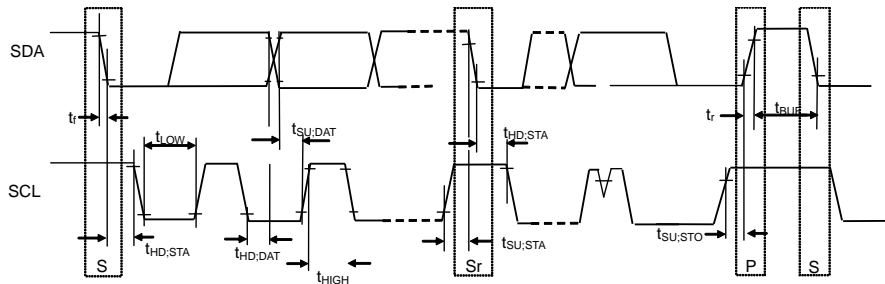

Figure 13. I<sup>2</sup>C BUS Interface Timing

BD2606MVV operates as a slave device for the I<sup>2</sup>C BUS interface.

● Slave Address

A7	A6	A5	A4	A3	A2	A1	R/W
1	1	0	0	1	1	0	1/0

● Data Format

The data format is shown below.

Write format:

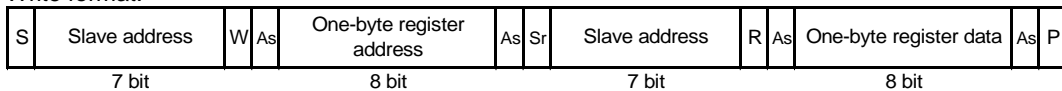

Or

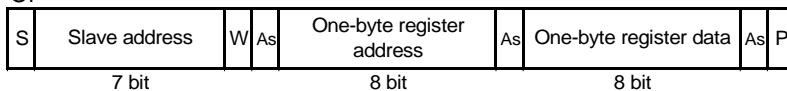

Read format:

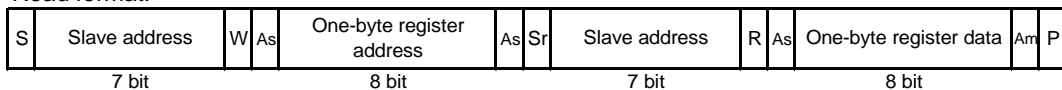

- (Note)
- S: Start condition
  - W: '0'=Write
  - R: '1'=Read
  - As: Acknowledge (slave -> master)
  - Am: No acknowledge
  - Sr: Repeated start condition
  - P: Stop condition

## (b) Register Table

## ● Register Map

Address Hex	Register name	D7	D6	D5	D4	D3	D2	D1	D0	Function
0x00	LEDACNT	-	-	LEDACNT					Current setting of ILEDA1/2	
0x01	LEDBCNT	-	-	LEDBCNT					Current setting of ILEDB1/2	
0x02	LEDCCNT	-	-	LEDCCNT					Current setting of ILEDC1/2	
0x03	LEDPWR CNT	-	FREQNT 1/0	LEDC2	LEDC1	LEDB2	LEDB1	LEDA2	LEDA1	Current driver ON/OFF control

(Note) 'L': Invalid at write time  
'L': 'L' at read time

## ● Description of Registers

LEDACNT (initial value: undefined) --- <Address: 0x00, Data: [D5: D0]>

LEDBCNT (initial value: undefined) --- <Address: 0x01, Data: [D5: D0]>

LEDCCNT (initial value: undefined) --- <Address: 0x02, Data: [D5: D0]>

LED current values are controlled. LEDA1/A2, LEDB1/B2 and LEDC1/C2 are controlled through the registers LEDACNT, LEDBCNT and LEDCCNT respectively, and the current setting can be switched every 2 channels.

For the current setting value in each register setting, refer to 'LED Current Setting Table' on page 9.

LEDA1 (initial value: '0') --- <Address: 0x03, Data: D0>

LEDA2 (initial value: '0') --- <Address: 0x03, Data: D1>

LEDB1 (initial value: '0') --- <Address: 0x03, Data: D2>

LEDB2 (initial value: '0') --- <Address: 0x03, Data: D3>

LEDC1 (initial value: '0') --- <Address: 0x03, Data: D4>

LEDC2 (initial value: '0') --- <Address: 0x03, Data: D5>

The ON/OFF setting of each LED driver channel is as follows:

'0': OFF

'1': ON

FREQCNT (initial value: '0') --- <Address: 0x03, Data: D6>

The switching frequency of a charge pump is set as follows:

'0': 1MHz

'1': 250kHz

When '250kHz' is selected, the flying capacitor of C<sub>1</sub>, C<sub>2</sub> and C<sub>OUT</sub> must be set to 10μF.

- LED Current Setting Table

The following table lists the current setting values for the respective register settings.

Initially, these registers have not been initialized. For this reason, they are not initialized under EN= '0'.

D5	D4	D3	D2	D1	D0	Output Current (mA)	D5	D4	D3	D2	D1	D0	Output Current (mA)
0	0	0	0	0	0	0.5	1	0	0	0	0	0	16.5
0	0	0	0	0	1	1.0	1	0	0	0	0	1	17.0
0	0	0	0	1	0	1.5	1	0	0	0	1	0	17.5
0	0	0	0	1	1	2.0	1	0	0	0	1	1	18.0
0	0	0	1	0	0	2.5	1	0	0	1	0	0	18.5
0	0	0	1	0	1	3.0	1	0	0	1	0	1	19.0
0	0	0	1	1	0	3.5	1	0	0	1	1	0	19.5
0	0	0	1	1	1	4.0	1	0	0	1	1	1	20.0
0	0	1	0	0	0	4.5	1	0	1	0	0	0	20.5
0	0	1	0	0	1	5.0	1	0	1	0	0	1	21.0
0	0	1	0	1	0	5.5	1	0	1	0	1	0	21.5
0	0	1	0	1	1	6.0	1	0	1	0	1	1	22.0
0	0	1	1	0	0	6.5	1	0	1	1	0	0	22.5
0	0	1	1	0	1	7.0	1	0	1	1	0	1	23.0
0	0	1	1	1	0	7.5	1	0	1	1	1	0	23.5
0	0	1	1	1	1	8.0	1	0	1	1	1	1	24.0
0	1	0	0	0	0	8.5	1	1	0	0	0	0	24.5
0	1	0	0	0	1	9.0	1	1	0	0	0	1	25.0
0	1	0	0	1	0	9.5	1	1	0	0	1	0	25.5
0	1	0	0	1	1	10.0	1	1	0	0	1	1	26.0
0	1	0	1	0	0	10.5	1	1	0	1	0	0	26.5
0	1	0	1	0	1	11.0	1	1	0	1	0	1	27.0
0	1	0	1	1	0	11.5	1	1	0	1	1	0	27.5
0	1	0	1	1	1	12.0	1	1	0	1	1	1	28.0
0	1	1	0	0	0	12.5	1	1	1	0	0	0	28.5
0	1	1	0	0	1	13.0	1	1	1	0	0	1	29.0
0	1	1	0	1	0	13.5	1	1	1	0	1	0	29.5
0	1	1	0	1	1	14.0	1	1	1	0	1	1	30.0
0	1	1	1	0	0	14.5	1	1	1	1	0	0	30.5
0	1	1	1	0	1	15.0	1	1	1	1	0	1	31.0
0	1	1	1	1	0	15.5	1	1	1	1	1	0	31.5
0	1	1	1	1	1	16.0	1	1	1	1	1	1	32.0

## (2) Charge Pump

## (a) Description of Operations

Pin voltage comparison takes place at OUT control section, and then  $V_{OUT}$  generation takes place so that the LED cathode voltage with the highest  $V_F$  is set to 0.1V. A boost rate is changed automatically to a proper one at the Charge Pump Mode Control section so that operation can take place at possible low boost rate. When the current taken from the IN pin exceeds 600mA, the overcurrent limiter is activated and the IC resets. In addition, if the output voltage falls below 1.5V, the IC will reset due to short-circuit at the output.

## (b) Soft-Start Function

BD2606MVV has a soft start function that prevents rush current.

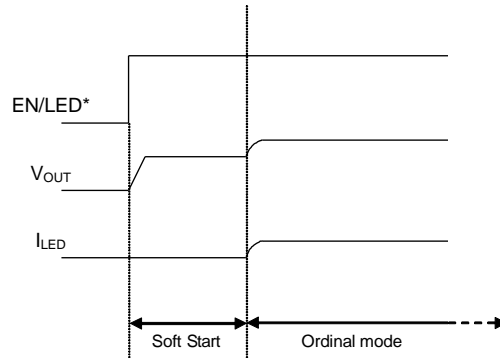

Figure 14. Soft-Start

## (c) Automatic Boost Rate Change

The boost rate automatically switches to the best mode.

- (x1 mode → x1.5 mode) or (x1.5 mode → x2 mode)  
If a battery voltage drop occurs, BD2606MVV cannot maintain the LED constant current and then mode transition begins.
- (x1.5 mode → x1 mode) or (x2 mode → x1.5 mode)  
If a battery voltage rise occurs, the output voltage ( $V_{OUT}$ ) and the supply voltage ( $V_{IN}$ ) detection are activated and then mode transition begins.

## (3) UVLO (Ultra Low Voltage Lock Out)

If the input voltage falls below 2.2V, BD2606MVV is shut down to prevent malfunction due to ultra-low voltage.

## (4) OVP (Over Voltage Protection)

This circuit protects the IC against damage when the C/P output voltage ( $V_{OUT}$ ) rises extremely for some external factors.

## (5) Thermal Shutdown (TSD)

To protect the IC against thermal damage or heat-driven uncontrolled operations, this circuit turns OFF the output if the chip temperature rises over 150°C.

**2. Recommended PCB Layout**

In PCB design, wire the power supply line in a way that the PCB impedance goes low and provide a bypass capacitor if needed. Heat radiation of back side PAD is used for improving the efficiency of IC heat radiation. Solder PAD to GND pin. Moreover, connect ground plane of board using via as shown in the patterns of below page. The efficiency of heat radiation improves according to the area of ground plane.

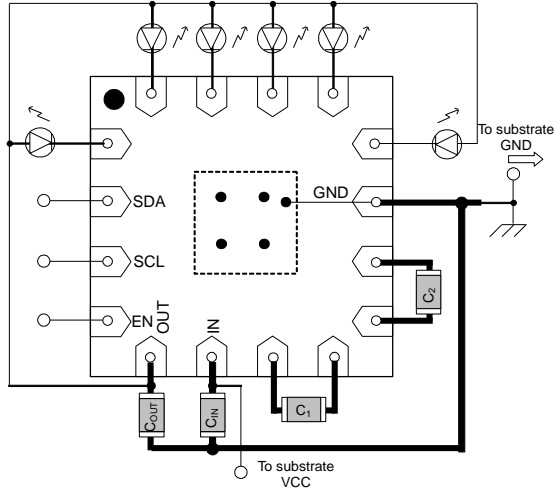

Figure 15. Application Layout Image (Top View)

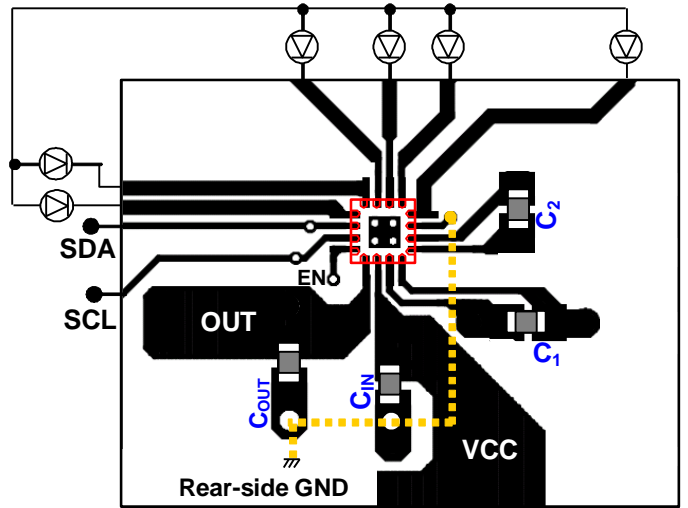

Figure 16. Front (Top View)

**3. Application Parts Selection Method**

Capacitor (Use a ceramic capacitor with good frequency and temperature characteristics)

Symbol	Recommended Value	Recommended Parts	Type
C <sub>OUT</sub> , C <sub>IN</sub> , C <sub>1</sub> , C <sub>2</sub>	1μF	GRM188B11A105KA61B(MURATA)	Ceramic capacitor

Connect an input bypass capacitor C<sub>IN</sub> between IN and GND pin and an output capacitor between OUT and GND pin in proximity. Place both C<sub>1P</sub>-C<sub>1N</sub> and C<sub>2P</sub>-C<sub>2N</sub> capacitors in proximity to the chip. Furthermore, select a ceramic capacitor with a sufficient rating for the voltage to be applied.

When other than these parts are used, the equivalent parts must be used.

## Operational Notes

### 1. Reverse Connection of Power Supply

Connecting the power supply in reverse polarity can damage the IC. Take precautions against reverse polarity when connecting the power supply, such as mounting an external diode between the power supply and the IC's power supply pins.

### 2. Power Supply Lines

Design the PCB layout pattern to provide low impedance supply lines. Separate the ground and supply lines of the digital and analog blocks to prevent noise in the ground and supply lines of the digital block from affecting the analog block. Furthermore, connect a capacitor to ground at all power supply pins. Consider the effect of temperature and aging on the capacitance value when using electrolytic capacitors.

### 3. Ground Voltage

Ensure that no pins are at a voltage below that of the ground pin at any time, even during transient condition.

### 4. Ground Wiring Pattern

When using both small-signal and large-current ground traces, the two ground traces should be routed separately but connected to a single ground at the reference point of the application board to avoid fluctuations in the small-signal ground caused by large currents. Also ensure that the ground traces of external components do not cause variations on the ground voltage. The ground lines must be as short and thick as possible to reduce line impedance.

### 5. Thermal Consideration

Should by any chance the power dissipation rating be exceeded the rise in temperature of the chip may result in deterioration of the properties of the chip. In case of exceeding this absolute maximum rating, increase the board size and copper area to prevent exceeding the Pd rating.

### 6. Recommended Operating Conditions

These conditions represent a range within which the expected characteristics of the IC can be approximately obtained. The electrical characteristics are guaranteed under the conditions of each parameter.

### 7. Inrush Current

When power is first supplied to the IC, it is possible that the internal logic may be unstable and inrush current may flow instantaneously due to the internal powering sequence and delays, especially if the IC has more than one power supply. Therefore, give special consideration to power coupling capacitance, power wiring, width of ground wiring, and routing of connections.

### 8. Operation Under Strong Electromagnetic Field

Operating the IC in the presence of a strong electromagnetic field may cause the IC to malfunction.

### 9. Testing on Application Boards

When testing the IC on an application board, connecting a capacitor directly to a low-impedance output pin may subject the IC to stress. Always discharge capacitors completely after each process or step. The IC's power supply should always be turned off completely before connecting or removing it from the test setup during the inspection process. To prevent damage from static discharge, ground the IC during assembly and use similar precautions during transport and storage.

### 10. Inter-pin Short and Mounting Errors

Ensure that the direction and position are correct when mounting the IC on the PCB. Incorrect mounting may result in damaging the IC. Avoid nearby pins being shorted to each other especially to ground, power supply and output pin. Inter-pin shorts could be due to many reasons such as metal particles, water droplets (in very humid environment) and unintentional solder bridge deposited in between pins during assembly to name a few.

Operational Notes – continued

11. **Unused Input Pins**

Input pins of an IC are often connected to the gate of a MOS transistor. The gate has extremely high impedance and extremely low capacitance. If left unconnected, the electric field from the outside can easily charge it. The small charge acquired in this way is enough to produce a significant effect on the conduction through the transistor and cause unexpected operation of the IC. So unless otherwise specified, unused input pins should be connected to the power supply or ground line.

12. **Regarding the Input Pin of the IC**

This monolithic IC contains P+ isolation and P substrate layers between adjacent elements in order to keep them isolated. P-N junctions are formed at the intersection of the P layers with the N layers of other elements, creating a parasitic diode or transistor. For example (refer to figure below):

When  $GND > Pin A$  and  $GND > Pin B$ , the P-N junction operates as a parasitic diode.  
 When  $GND > Pin B$ , the P-N junction operates as a parasitic transistor.

Parasitic diodes inevitably occur in the structure of the IC. The operation of parasitic diodes can result in mutual interference among circuits, operational faults, or physical damage. Therefore, conditions that cause these diodes to operate, such as applying a voltage lower than the GND voltage to an input pin (and thus to the P substrate) should be avoided.

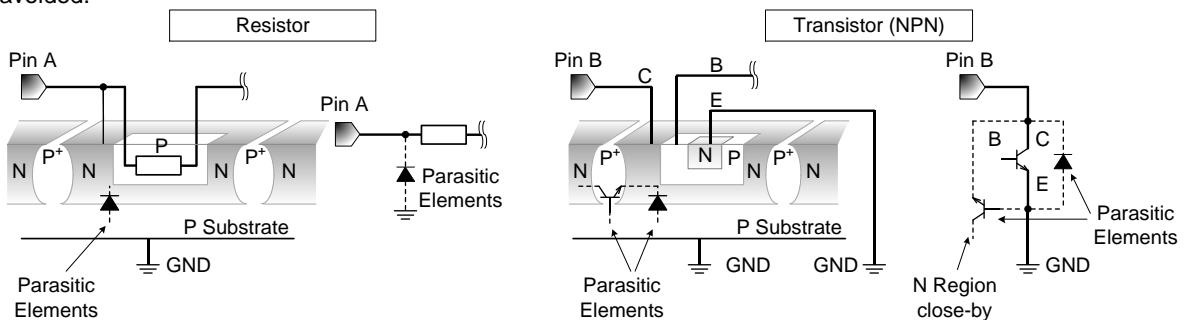

Figure 17. Example of monolithic IC structure

13. **Ceramic Capacitor**

When using a ceramic capacitor, determine the dielectric constant considering the change of capacitance with temperature and the decrease in nominal capacitance due to DC bias and others.

14. **Thermal Shutdown Circuit(TSD)**

This IC has a built-in thermal shutdown circuit that prevents heat damage to the IC. Normal operation should always be within the IC's power dissipation rating. If however the rating is exceeded for a continued period, the junction temperature ( $T_j$ ) will rise which will activate the TSD circuit that will turn OFF all output pins. When the  $T_j$  falls below the TSD threshold, the circuits are automatically restored to normal operation.

Note that the TSD circuit operates in a situation that exceeds the absolute maximum ratings and therefore, under no circumstances, should the TSD circuit be used in a set design or for any purpose other than protecting the IC from heat damage.

	TSD ON Temp. [°C] (typ)
BD2606MVV	175

Ordering Information

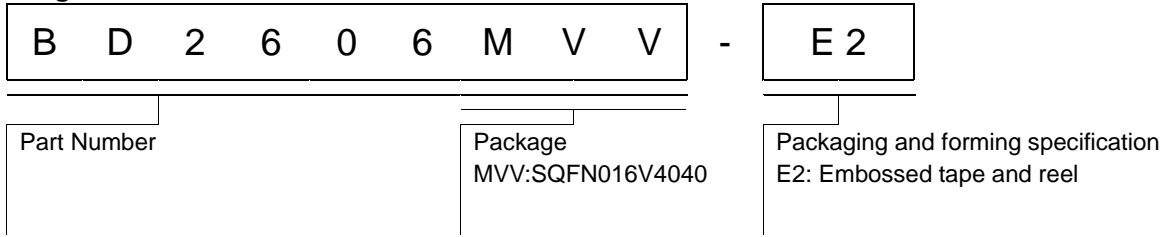

Marking Diagram

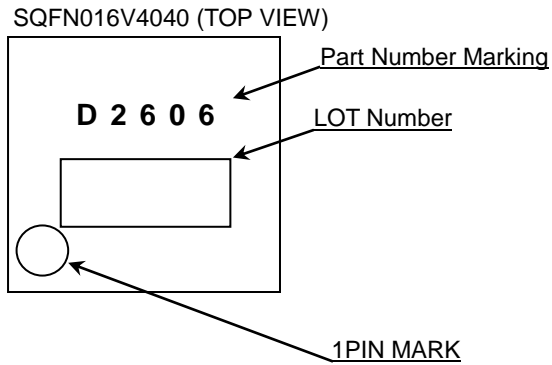

Physical Dimension, Tape and Reel Information

Package Name	SQFN016V4040
--------------	--------------

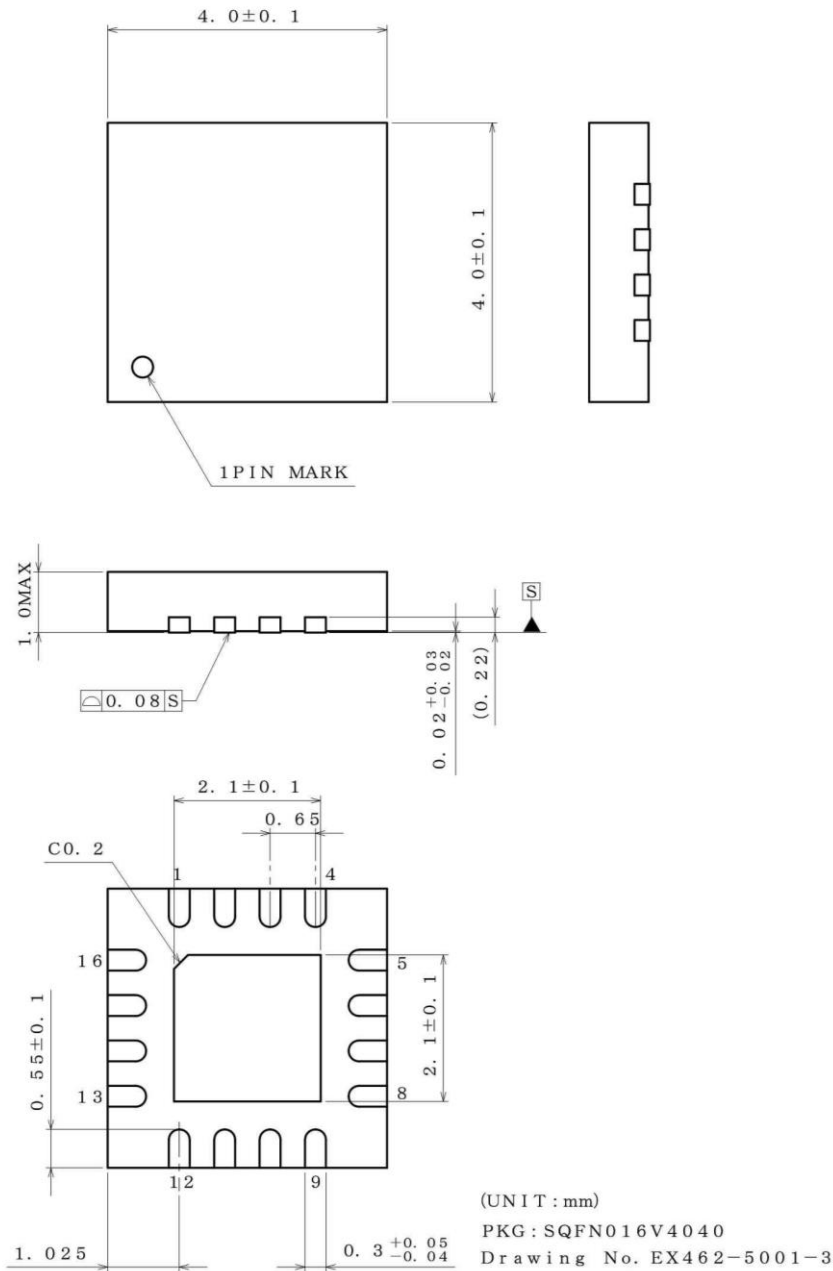

**<Tape and Reel information>**

Tape	Embossed carrier tape
Quantity	2500pcs
Direction of feed	E2 (The direction is the 1pin of product is at the upper left when you hold reel on the left hand and you pull out the tape on the right hand)

\*Order quantity needs to be multiple of the minimum quantity.

Revision History

Date	Revision	Changes
03.Dec.2012	001	New Release
10.Dec.2015	002	Applied the ROHM Standard Style and improved understandability.

# Notice

## Precaution on using ROHM Products

- Our Products are designed and manufactured for application in ordinary electronic equipments (such as AV equipment, OA equipment, telecommunication equipment, home electronic appliances, amusement equipment, etc.). If you intend to use our Products in devices requiring extremely high reliability (such as medical equipment <sup>(Note 1)</sup>, transport equipment, traffic equipment, aircraft/spacecraft, nuclear power controllers, fuel controllers, car equipment including car accessories, safety devices, etc.) and whose malfunction or failure may cause loss of human life, bodily injury or serious damage to property ("Specific Applications"), please consult with the ROHM sales representative in advance. Unless otherwise agreed in writing by ROHM in advance, ROHM shall not be in any way responsible or liable for any damages, expenses or losses incurred by you or third parties arising from the use of any ROHM's Products for Specific Applications.

(Note1) Medical Equipment Classification of the Specific Applications

JAPAN	USA	EU	CHINA
CLASS III	CLASS III	CLASS II b	CLASS III
CLASS IV		CLASS III	

- ROHM designs and manufactures its Products subject to strict quality control system. However, semiconductor products can fail or malfunction at a certain rate. Please be sure to implement, at your own responsibilities, adequate safety measures including but not limited to fail-safe design against the physical injury, damage to any property, which a failure or malfunction of our Products may cause. The following are examples of safety measures:
  - Installation of protection circuits or other protective devices to improve system safety
  - Installation of redundant circuits to reduce the impact of single or multiple circuit failure
- Our Products are designed and manufactured for use under standard conditions and not under any special or extraordinary environments or conditions, as exemplified below. Accordingly, ROHM shall not be in any way responsible or liable for any damages, expenses or losses arising from the use of any ROHM's Products under any special or extraordinary environments or conditions. If you intend to use our Products under any special or extraordinary environments or conditions (as exemplified below), your independent verification and confirmation of product performance, reliability, etc. prior to use, must be necessary:
  - Use of our Products in any types of liquid, including water, oils, chemicals, and organic solvents
  - Use of our Products outdoors or in places where the Products are exposed to direct sunlight or dust
  - Use of our Products in places where the Products are exposed to sea wind or corrosive gases, including Cl<sub>2</sub>, H<sub>2</sub>S, NH<sub>3</sub>, SO<sub>2</sub>, and NO<sub>2</sub>
  - Use of our Products in places where the Products are exposed to static electricity or electromagnetic waves
  - Use of our Products in proximity to heat-producing components, plastic cords, or other flammable items
  - Sealing or coating our Products with resin or other coating materials
  - Use of our Products without cleaning residue of flux (even if you use no-clean type fluxes, cleaning residue of flux is recommended); or Washing our Products by using water or water-soluble cleaning agents for cleaning residue after soldering
  - Use of the Products in places subject to dew condensation
- The Products are not subject to radiation-proof design.
- Please verify and confirm characteristics of the final or mounted products in using the Products.
- In particular, if a transient load (a large amount of load applied in a short period of time, such as pulse. is applied, confirmation of performance characteristics after on-board mounting is strongly recommended. Avoid applying power exceeding normal rated power; exceeding the power rating under steady-state loading condition may negatively affect product performance and reliability.
- De-rate Power Dissipation depending on ambient temperature. When used in sealed area, confirm that it is the use in the range that does not exceed the maximum junction temperature.
- Confirm that operation temperature is within the specified range described in the product specification.
- ROHM shall not be in any way responsible or liable for failure induced under deviant condition from what is defined in this document.

## Precaution for Mounting / Circuit board design

- When a highly active halogenous (chlorine, bromine, etc.) flux is used, the residue of flux may negatively affect product performance and reliability.
- In principle, the reflow soldering method must be used on a surface-mount products, the flow soldering method must be used on a through hole mount products. If the flow soldering method is preferred on a surface-mount products, please consult with the ROHM representative in advance.

For details, please refer to ROHM Mounting specification

**Precautions Regarding Application Examples and External Circuits**

1. If change is made to the constant of an external circuit, please allow a sufficient margin considering variations of the characteristics of the Products and external components, including transient characteristics, as well as static characteristics.
2. You agree that application notes, reference designs, and associated data and information contained in this document are presented only as guidance for Products use. Therefore, in case you use such information, you are solely responsible for it and you must exercise your own independent verification and judgment in the use of such information contained in this document. ROHM shall not be in any way responsible or liable for any damages, expenses or losses incurred by you or third parties arising from the use of such information.

**Precaution for Electrostatic**

This Product is electrostatic sensitive product, which may be damaged due to electrostatic discharge. Please take proper caution in your manufacturing process and storage so that voltage exceeding the Products maximum rating will not be applied to Products. Please take special care under dry condition (e.g. Grounding of human body / equipment / solder iron, isolation from charged objects, setting of Ionizer, friction prevention and temperature / humidity control).

**Precaution for Storage / Transportation**

1. Product performance and soldered connections may deteriorate if the Products are stored in the places where:
  - [a] the Products are exposed to sea winds or corrosive gases, including Cl<sub>2</sub>, H<sub>2</sub>S, NH<sub>3</sub>, SO<sub>2</sub>, and NO<sub>2</sub>
  - [b] the temperature or humidity exceeds those recommended by ROHM
  - [c] the Products are exposed to direct sunshine or condensation
  - [d] the Products are exposed to high Electrostatic
2. Even under ROHM recommended storage condition, solderability of products out of recommended storage time period may be degraded. It is strongly recommended to confirm solderability before using Products of which storage time is exceeding the recommended storage time period.
3. Store / transport cartons in the correct direction, which is indicated on a carton with a symbol. Otherwise bent leads may occur due to excessive stress applied when dropping of a carton.
4. Use Products within the specified time after opening a humidity barrier bag. Baking is required before using Products of which storage time is exceeding the recommended storage time period.

**Precaution for Product Label**

QR code printed on ROHM Products label is for ROHM's internal use only.

**Precaution for Disposition**

When disposing Products please dispose them properly using an authorized industry waste company.

**Precaution for Foreign Exchange and Foreign Trade act**

Since concerned goods might be fallen under listed items of export control prescribed by Foreign exchange and Foreign trade act, please consult with ROHM in case of export.

**Precaution Regarding Intellectual Property Rights**

1. All information and data including but not limited to application example contained in this document is for reference only. ROHM does not warrant that foregoing information or data will not infringe any intellectual property rights or any other rights of any third party regarding such information or data.
2. ROHM shall not have any obligations where the claims, actions or demands arising from the combination of the Products with other articles such as components, circuits, systems or external equipment (including software).
3. No license, expressly or implied, is granted hereby under any intellectual property rights or other rights of ROHM or any third parties with respect to the Products or the information contained in this document. Provided, however, that ROHM will not assert its intellectual property rights or other rights against you or your customers to the extent necessary to manufacture or sell products containing the Products, subject to the terms and conditions herein.

**Other Precaution**



1. This document may not be reprinted or reproduced, in whole or in part, without prior written consent of ROHM.
2. The Products may not be disassembled, converted, modified, reproduced or otherwise changed without prior written consent of ROHM.
3. In no event shall you use in any way whatsoever the Products and the related technical information contained in the Products or this document for any military purposes, including but not limited to, the development of mass-destruction weapons.
4. The proper names of companies or products described in this document are trademarks or registered trademarks of ROHM, its affiliated companies or third parties.

**General Precaution**

1. Before you use our Products, you are requested to carefully read this document and fully understand its contents. ROHM shall not be in any way responsible or liable for failure, malfunction or accident arising from the use of any ROHM's Products against warning, caution or note contained in this document.
2. All information contained in this document is current as of the issuing date and subject to change without any prior notice. Before purchasing or using ROHM's Products, please confirm the latest information with a ROHM sales representative.
3. The information contained in this document is provided on an "as is" basis and ROHM does not warrant that all information contained in this document is accurate and/or error-free. ROHM shall not be in any way responsible or liable for any damages, expenses or losses incurred by you or third parties resulting from inaccuracy or errors of or concerning such information.

## Looking for pricing, stock, or lifecycle information?

Click below to explore more details on WIN SOURCE:

-  [View BD2606MVV-E2 on WIN SOURCE](#)
-  [Rohm Semiconductor](#) Information

## Optimize Your Supply Chain with WIN SOURCE Solutions

-  Global Sourcing Solution
-  Obsolete Management
-  Cost Control Management
-  Shortage Management
-  Alternative Solution
-  Excess Inventory Management