



**THE DATASHEET OF  
BCR402UW6-7**



## Description

The BCR402UW6 monolithically integrates a transistor, diodes, and resistors to function as a Constant Current Regulator (CCR) for LED driving. The device regulates with a preset 20mA nominal that can be adjusted with an external resistor up to 100mA. It is designed for driving LEDs in strings and reduces current at increasing temperatures to self-protect. Operating as a series linear CCR for LED string current control, it can be used in applications with supply voltages up to 40V.

Without requiring additional external components, this CCR is fully integrated into the SOT26 package, minimizing PCB area and component count.

## Features

- LED Constant Current Regulator Using PNP Emitter-Follower with Emitter Resistor to Current Limit
- $I_{OUT} = 20mA \pm 10\%$  Constant Current (Preset)
- $I_{OUT}$  up to 100mA Adjustable with an External Resistor
- $V_S - 40V$  Supply Voltage
- $P_D$  up to 1W in SOT26
- LED Dimming Using PWM up to 25kHz
- Negative Temperature Coefficient (NTC) Reduces  $I_{OUT}$  with Increasing Temperature
- Parallel Devices to Increase Regulated Current
- **Totally Lead-Free & Fully RoHS Compliant (Notes 1 & 2)**
- **Halogen and Antimony Free. "Green" Device (Note 3)**
- **An automotive-compliant part is available under separate datasheet ([BCR402UW6Q](#))**

## Applications

Constant Current Regulation (CCR) in:

- Emergency lighting
- Signage, advertising, and decorative/architectural lighting
- Retail lighting in refrigerators, freezer cases, and vending machines

## Mechanical Data

- Package: SOT26
- Package Material: Molded Plastic. "Green" Molding Compound. UL Flammability Rating 94V-0
- Moisture Sensitivity: Level 1 per J-STD-020
- Terminals: Finish - Matte Tin Plated Leads, Solderable per MIL-STD-202, Method 208 Ⓢ3
- Weight: 0.018 grams (Approximate)

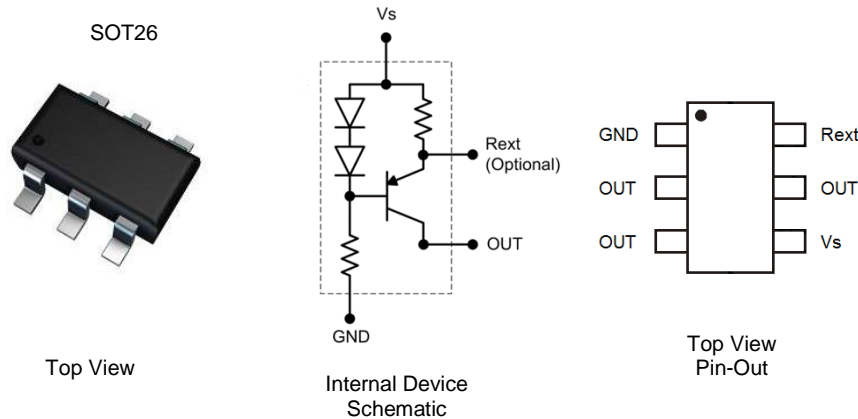

Pin Name	Pin Function
$V_S$	Supply Voltage
OUT	Regulated Output Current
Rext	External resistor for adjusting Output Current
GND	Power Ground

## Ordering Information (Note 4)

Orderable Part Number	Marking	Reel Size (inches)	Tape Width (mm)	Packing	
				Quantity	Carrier
BCR402UW6-7	402	7	8	3,000	Reel

- Notes:
1. No purposely added lead. Fully EU Directive 2002/95/EC (RoHS), 2011/65/EU (RoHS 2) & 2015/863/EU (RoHS 3) compliant.
  2. See <https://www.diodes.com/quality/lead-free/> for more information about Diodes Incorporated's definitions of Halogen- and Antimony-free, "Green" and Lead-free.
  3. Halogen- and Antimony-free "Green" products are defined as those which contain <900ppm bromine, <900ppm chlorine (<1500ppm total Br + Cl) and <1000ppm antimony compounds.
  4. For packaging details, go to our website at <https://www.diodes.com/design/support/packaging/diodes-packaging/>.

## Marking Information

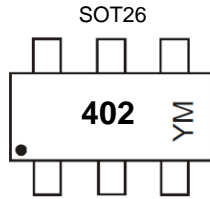

402 = Part Marking (See Ordering Information)  
 YM = Date Code Marking  
 Y = Year (ex: 1 = 2021)  
 M = Month (ex: 9 = September)

### Date Code Key

Year	2016	...	2021	2022	2023	2024	2025	2026	2027	2028	2029	2030
Code	D	...	I	J	K	L	M	N	P	R	S	T

Month	Jan	Feb	Mar	Apr	May	Jun	Jul	Aug	Sep	Oct	Nov	Dec
Code	1	2	3	4	5	6	7	8	9	O	N	D

## Absolute Maximum Ratings (Voltage relative to GND, @T<sub>A</sub> = +25°C, unless otherwise specified.)

Characteristic	Symbol	Value	Unit
Supply Voltage	V <sub>S</sub>	40	V
Output Current	I <sub>OUT</sub>	100	mA
Output Voltage	V <sub>OUT</sub>	40	V
Reverse Voltage Between All Terminals	V <sub>R</sub>	0.5	V

## Thermal Characteristics

Characteristic	Symbol	Value	Unit
Power Dissipation	P <sub>D</sub>	(Note 5)	1190
		(Note 6)	912
Thermal Resistance, Junction to Ambient	R <sub>θJA</sub>	(Note 5)	105
		(Note 6)	137
Thermal Resistance, Junction to Lead	R <sub>θJL</sub>	50	°C/W
Recommended Operating Junction Temperature Range	T <sub>J</sub>	-55 to +150	°C
Maximum Operating Junction and Storage Temperature Range	T <sub>J</sub> , T <sub>STG</sub>	-65 to +150	

Notes: 5. For a device mounted with the OUT leads on 50mm x 50mm 1oz copper that is on a single-sided 1.6mm FR4 PCB; device is measured under still air conditions while operating in steady-state.  
 6. Same as Note 5, except mounted on 25mm x 25mm 1oz copper.  
 7. R<sub>θJL</sub> = Thermal resistance from junction to solder-point (at the end of the OUT leads).

## ESD Ratings (Note 8)

Characteristics	Symbols	Value	Unit	JEDEC Class
Electrostatic Discharge – Human Body Model	ESD HBM	800	V	1B
Electrostatic Discharge – Machine Model	ESD MM	300	V	B
Electrostatic Discharge – Charged Device Model	ESD CDM	1000	V	C6

Notes: 8. Refer to JEDEC specification JESD22-A114 and JESD22-A115.

## Electrical Characteristics (@ T<sub>A</sub> = +25°C, unless otherwise specified.)

Characteristic	Symbol	Min	Typ	Max	Unit	Test Condition
Collector-Emitter Breakdown Voltage	BV <sub>CEO</sub>	40	—	—	V	I <sub>C</sub> = 1mA
GND (Enable) Current	I <sub>GND</sub>	340	420	500	μA	V <sub>S</sub> = 10V; V <sub>OUT</sub> = Open
GND (Enable) Current	I <sub>GND</sub>	—	380	—	μA	V <sub>S</sub> = 10V; V <sub>OUT</sub> = 8.6V
DC Current Gain	h <sub>FE</sub>	100	220	470	—	I <sub>C</sub> = 50mA; V <sub>CE</sub> = 1V
Internal Resistor	R <sub>INT</sub>	38	44	52	Ω	I <sub>RINT</sub> = 20mA
Output Current (Nominal)	I <sub>OUT</sub>	18	20	22	mA	V <sub>OUT</sub> = 8.6V; V <sub>S</sub> = 10V
Output Current	I <sub>OUT</sub>	25	28	31	mA	V <sub>S</sub> = 12V; R <sub>ext</sub> = 95Ω
		31	35	39	mA	V <sub>S</sub> = 12V; R <sub>ext</sub> = 53Ω
		57	63	69	mA	V <sub>S</sub> = 10V; R <sub>ext</sub> = 17Ω
Voltage Drop (V <sub>REXT</sub> )	V <sub>DROP</sub>	—	0.88	—	V	I <sub>OUT</sub> = 20mA
Lowest Sufficient Supply Voltage (V <sub>S</sub> -V <sub>OUT</sub> )	V <sub>SMIN</sub>	—	1.4	—	V	I <sub>OUT</sub> > 18mA
Output Current Change vs. Temperature	ΔI <sub>OUT</sub> /I <sub>OUT</sub>	—	-0.25	—	%/°C	V <sub>S</sub> = 10V
Output Current Change vs. Supply Voltage	ΔI <sub>OUT</sub> /I <sub>OUT</sub>	—	1	—	%/V	V <sub>S</sub> = 10V

**Typical Thermal Characteristics** (@  $T_A = +25^\circ\text{C}$ , unless otherwise specified.)

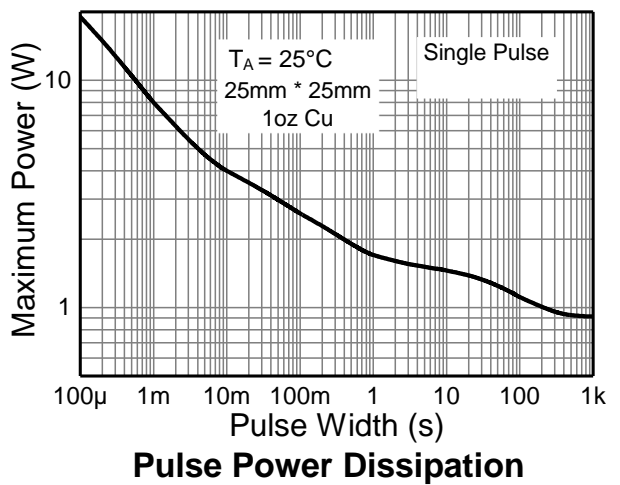
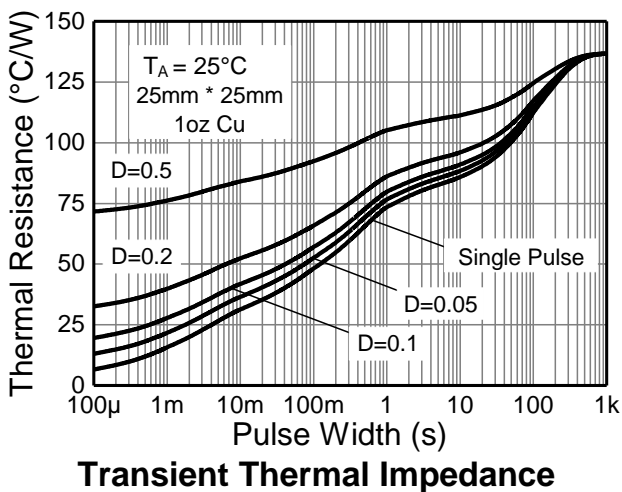
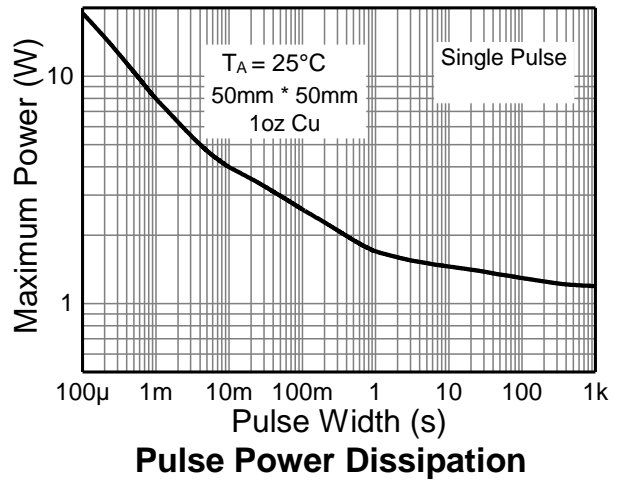
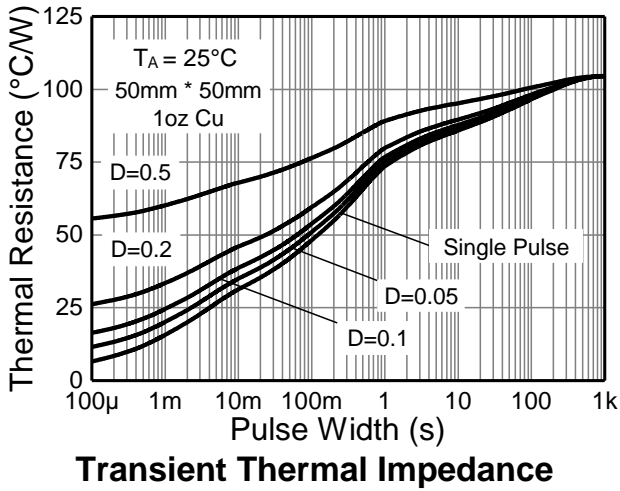
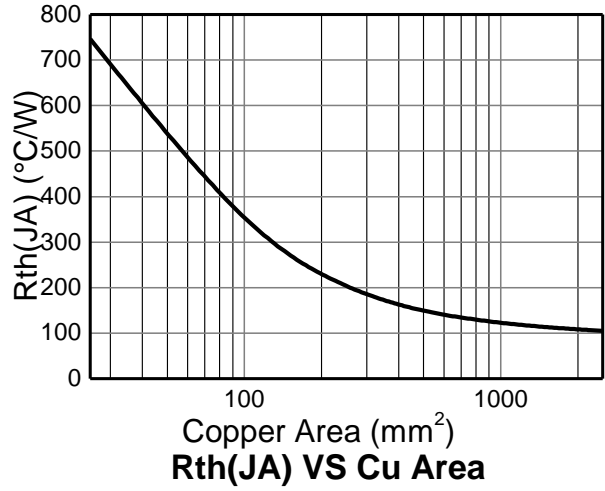
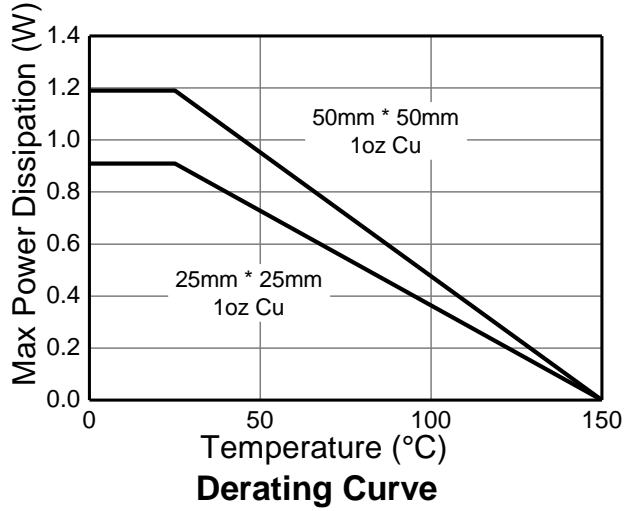

**Typical Electrical Characteristics** (@  $T_A = +25^\circ\text{C}$ , unless otherwise specified.) (continued)

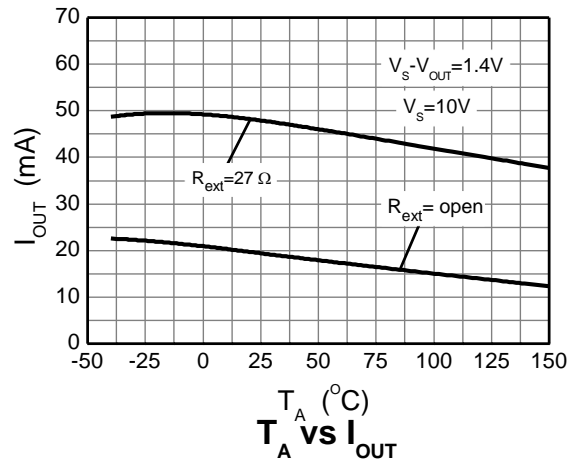
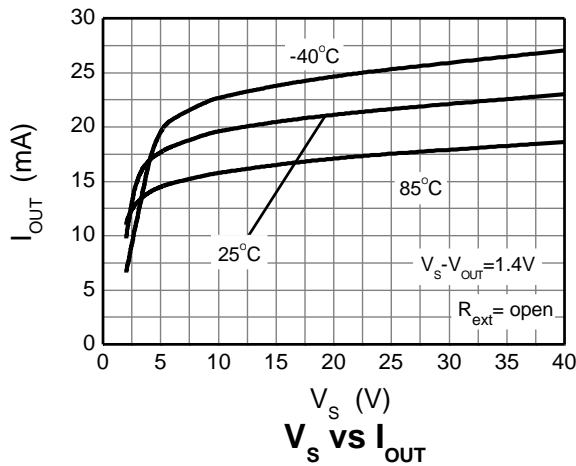
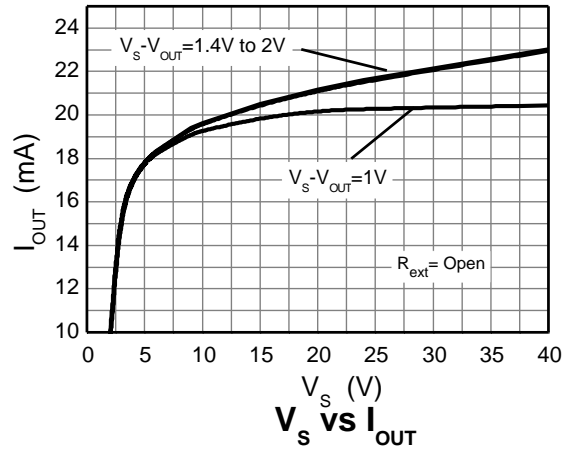
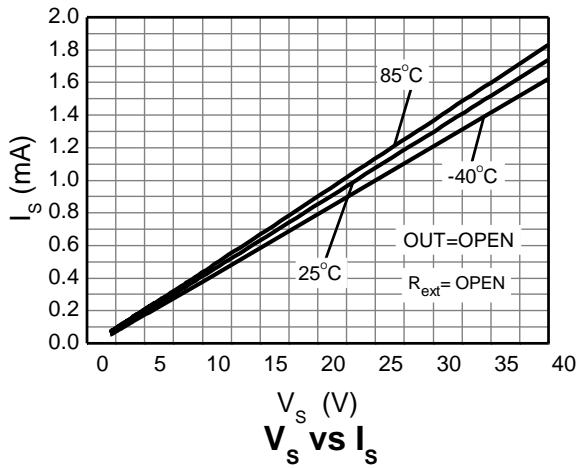
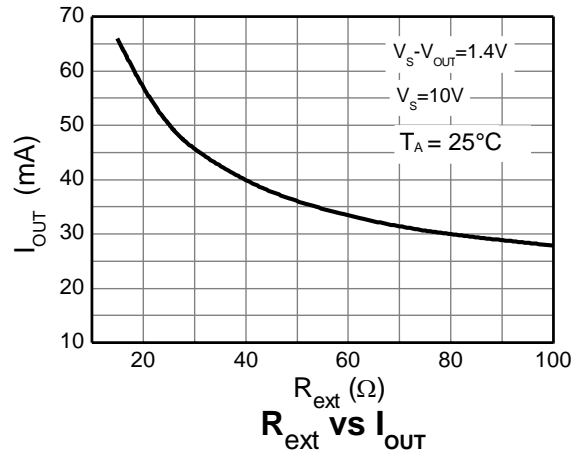
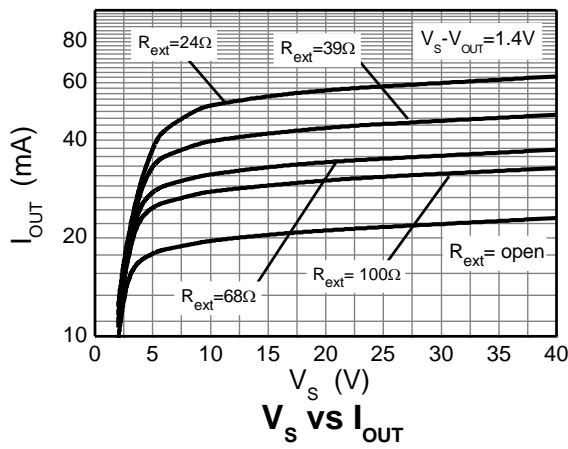

**Application Information**

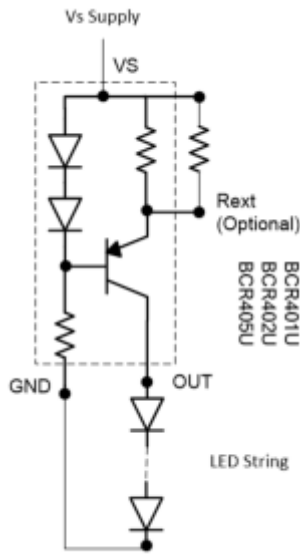

Figure 1 Typical Application Circuit for BCR40x LED Driver

The BCR401/2/5 are designed for driving low-current LEDs with typical LED currents of 10mA to 100mA. They provide a cost-effective way for driving low-current LEDs compared to more complex switching regulator solutions. Furthermore, they reduce the PCB board area of the solution as there is no requirement for external components like inductors, capacitors, and switching diodes.

Figure 1 shows a typical application circuit diagram for driving an LED or string of LEDs. The devices come with an internal resistor ( $R_{INT}$ ) of typically 91Ω, 44Ω, or 16.5Ω which, in the absence of an external resistor, sets an LED current of 10mA, 20mA, 50mA, respectively. LED current can be increased to a desired value by choosing an appropriate external resistor,  $R_{ext}$ .

The  $R_{ext}$  vs.  $I_{OUT}$  graphs should be used to select the appropriate resistor. Choosing a low tolerance  $R_{ext}$  improves the overall accuracy of the current sense formed by the parallel connection of  $R_{INT}$  and  $R_{ext}$ .

The negative temperature coefficient of the BCR series allows easy paralleling of BCR410/2/5s. In applications where current sharing is required either due to high current requirements of LED strings or for power sharing, two or more BCR401/2/5s can be connected in parallel, as shown in Figure 2. Power dissipation capability must be factored into the design with respect to the BCR401/2/5's thermal resistance. The maximum voltage across the device can be calculated by taking the maximum supply voltage and subtracting the voltage across the LED string.

$$V_{DEVICE} = V_S - V_{OUT}$$

$$P_D = (V_{DEVICE} \times I_{LED}) + (V_S \times I_{GND})$$

As the output current of BCR401/2/5 increases, it is necessary to connect an appropriate heat sink to the OUT pins of the device. The power dissipation supported by the device is dependent upon the PCB board material, the copper area, and the ambient temperature. The maximum dissipation the device can handle is given by:

$$P_D = (T_{J(MAX)} - T_A) / R_{\theta JA}$$

See the thermal characteristic graphs on page 4 for selecting the appropriate PCB copper area.

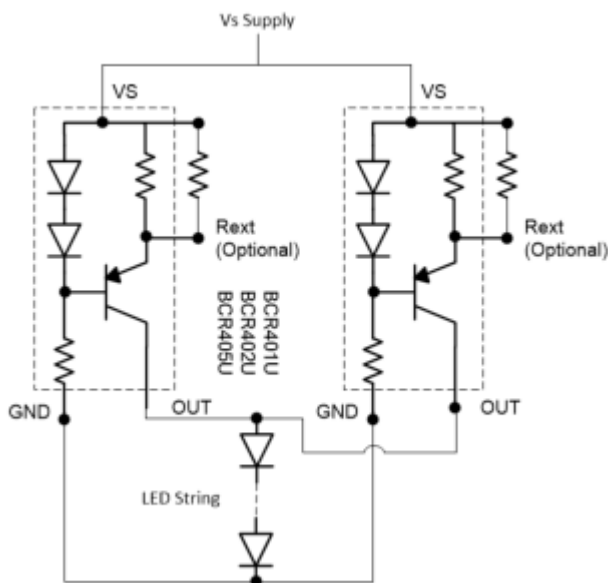

Figure 2 Application Circuit for Increasing LED Current

**Application Information** (continued)

PWM is the most pursued method for LED dimming. In the PWM method, dimming is achieved by turning the LEDs ON and OFF for a portion of a single cycle. PWM dimming can be achieved by enabling/disabling the LED driver itself (see Figure 3a ,3b) or by the switching the power path on and off (see Figure 3c). The PWM signal can be provided by a microcontroller or analog circuitry; typical circuits are shown in Figure 3. Figure 4 is a typical response of LED current vs. PWM duty cycle. Figure 3b shows the PWM method that is used for generating the graphs.

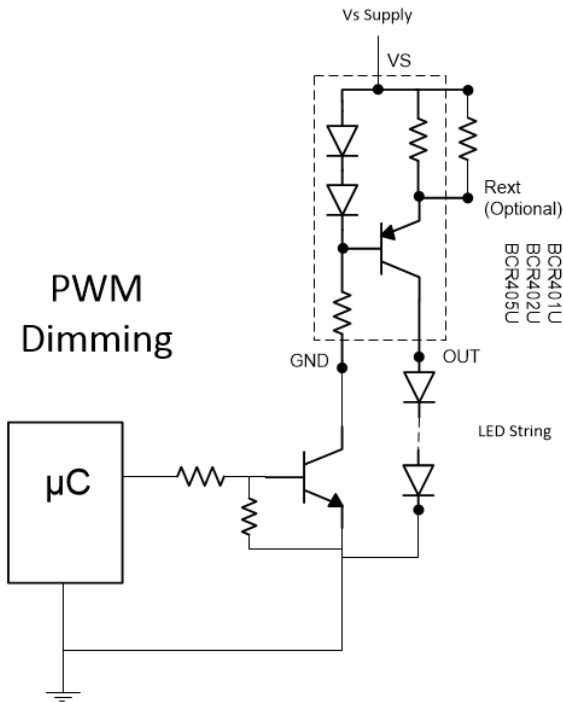

Figure 3a

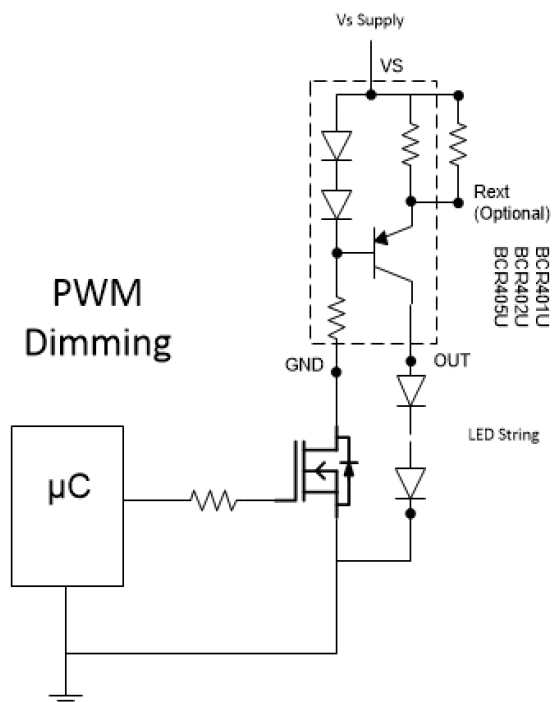

Figure 3b

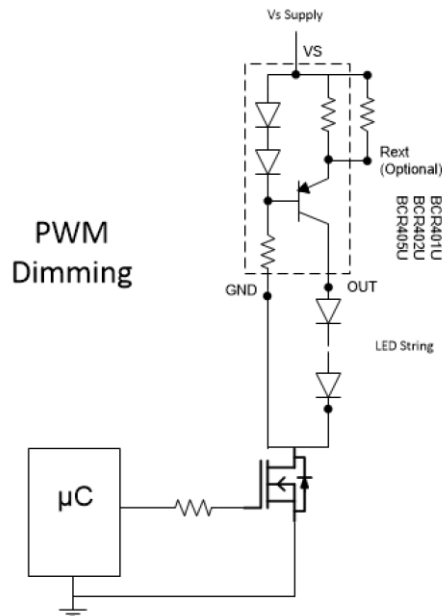

Figure 3c

Figure 3a, 3b, & 3c. Application Circuits for LED Driver with PWM Dimming Functionality

**Application Information** (continued)

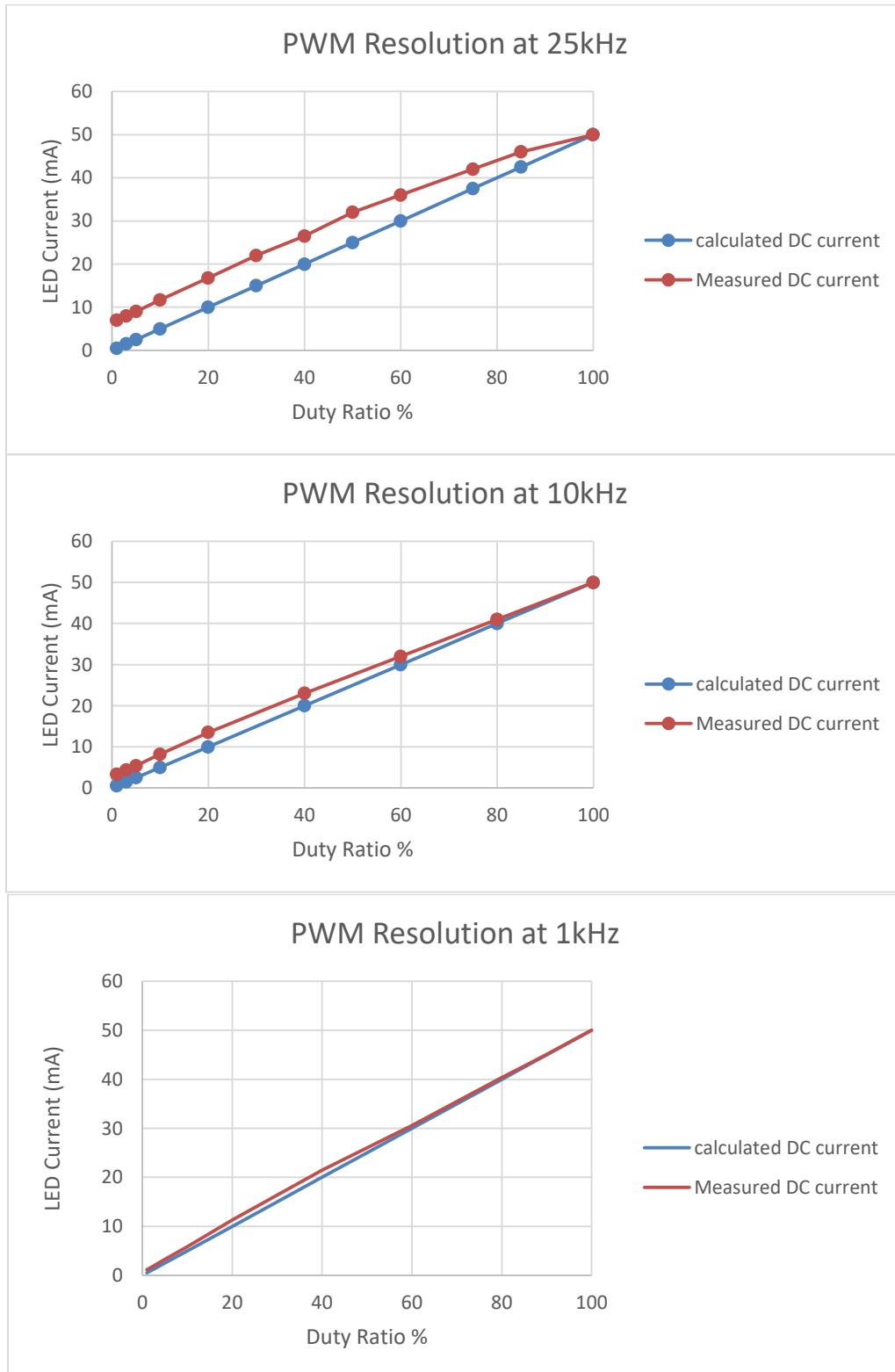

Figure 4 Typical LED Current Response vs. PWM Duty Cycle for 25kHz, 10kHz, and 1kHz PWM Frequency (See Figure 3b)

**Application Information** (continued)

The error between the calculated theoretical value and the measured value is due to the turn-on and turn-off times of the BCR401/2/5. There is a small contribution from the switches (a pre-biased transistor or a MOSFET), shown in Figure 3a and 3b, towards the total turn-on and turn-off times of the BCR401/2/5. It is recommended to keep the external switching delays to the lowest possible value to improve PWM accuracy. The typical switching times of the BCR401/2/5 for the configuration shown in Figure 3b are;

Turn-On Time = 200ns  
Turn-Off Time = 10µs

See figures 5 and 6 for the switching time performance. Figure 4 shows the percentage contribution of these switching delays increases with increasing frequency and decreasing duty ratio.

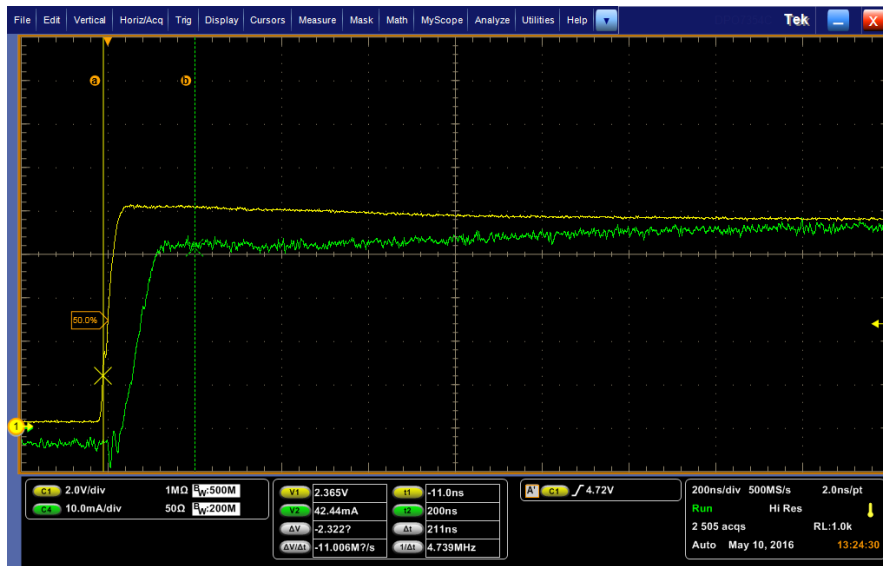

Figure 5 Turn-On Time of BCR401/2/5 (PWM Method Shown in Figure 3b)



Figure 6 Turn-On Time of BCR401/2/5 (PWM Method Shown in Figure 3c)

However, where possible, the switching performance of the BCR401/2/5 can be significantly improved by switching the power path as shown in Figure 3c. Figure 7 shows the resulting turn-off time. This results in an improved PWM resolution at 25kHz as shown in Figure 8.

Turn-Off Time = ~200ns

**Application Information** (continued)

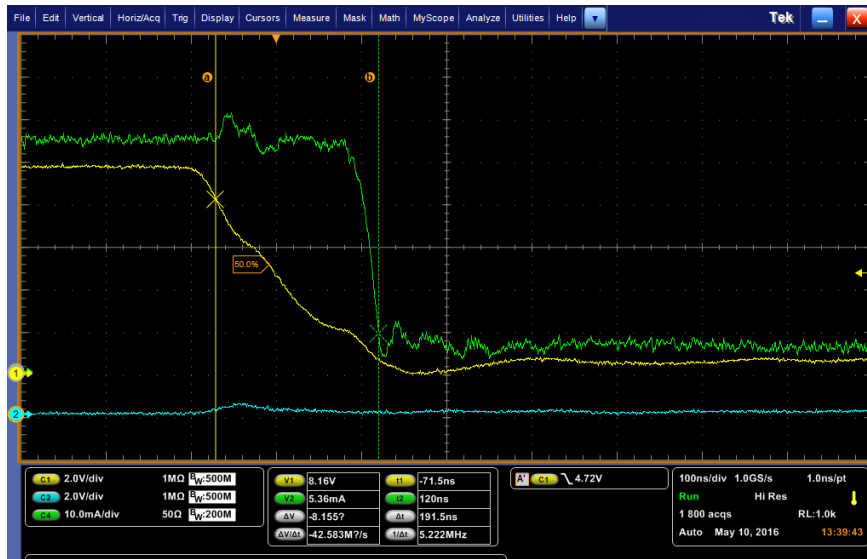

Figure 7 Turn-Off Time of BCR401/2/5 while Switching the Power Path as Shown in Figure 3c

Yellow → PWM Signal  
 Green → LED Current  
 Blue → No Connection Made to this Probe Channel



Figure 8 PWM Resolution with Power Path Switching (Refer to Figure 3c)

**Application Information** (continued)

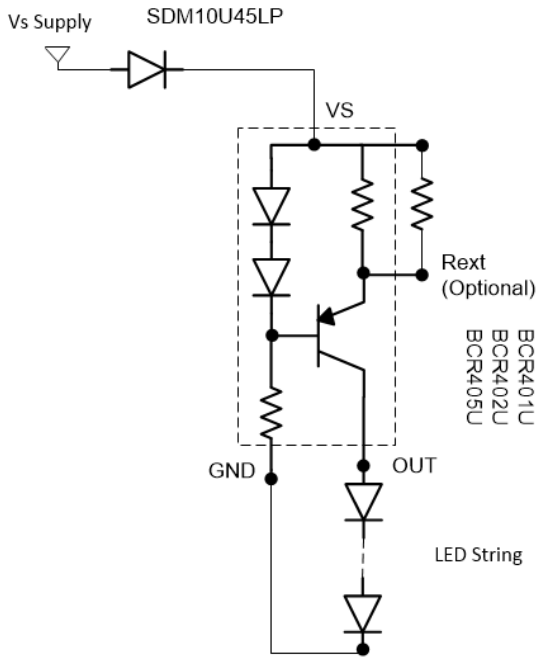

Figure 9 Application Circuit for LED Driver with Reverse Polarity Protection

To remove the potential damage to the lamp's LED due to an incorrect connection of the power supply, many systems use some form of reverse polarity protection.

One solution for reverse input polarity protection is to simply use a diode with a low  $V_F$  in line with the driver/LED combination. The low  $V_F$  increases the available voltage to the LED stack and dissipates less power. Figure 9 shows a circuit example that protects the light engine; however, it will not function until the problem is diagnosed and corrected. Figure 9 shows an SDM10U45LP (0.1A/45V), which provides exceptionally low  $V_F$  for its package size of 1mm x 0.6mm. Other reverse voltage ratings are available from Diodes Incorporated's website, such as the SBR02U100LP (0.2A/100V) or SBR0220LP (0.2A/20V).

While automotive applications commonly use this method for reverse battery protection, an alternative approach, shown in Figure 10, provides reverse polarity protection and corrects the reversed polarity, allowing the light engine to function.

The BAS40BRW incorporates four low  $V_F$  Schottky diodes in a single package, reducing the power dissipated and maximizes the voltage across the LED stack.

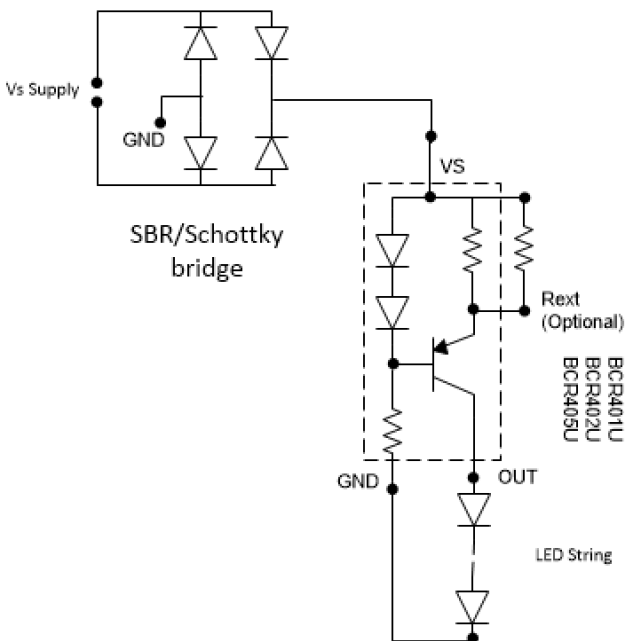
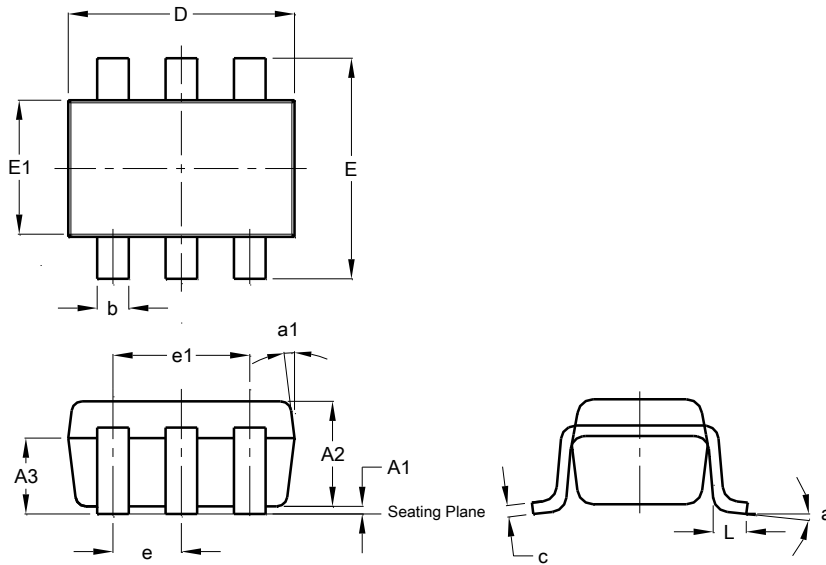

Figure 10 Application Circuit for LED Driver with Assured Operation Regardless of Polarity

**Package Outline Dimensions**

Please see <http://www.diodes.com/package-outlines.html> for the latest version.

**SOT26**



SOT26			
Dim	Min	Max	Typ
A1	0.013	0.10	0.05
A2	1.00	1.30	1.10
A3	0.70	0.80	0.75
b	0.35	0.50	0.38
c	0.10	0.20	0.15
D	2.90	3.10	3.00
e	-	-	0.95
e1	-	-	1.90
E	2.70	3.00	2.80
E1	1.50	1.70	1.60
L	0.35	0.55	0.40
a	-	-	8°
a1	-	-	7°
All Dimensions in mm			

**Suggested Pad Layout**

Please see <http://www.diodes.com/package-outlines.html> for the latest version.

**SOT26**

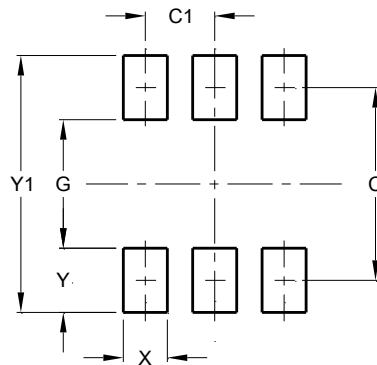

Dimensions	Value (in mm)
C	2.40
C1	0.95
G	1.60
X	0.55
Y	0.80
Y1	3.20

**IMPORTANT NOTICE**



1. DIODES INCORPORATED (Diodes) AND ITS SUBSIDIARIES MAKE NO WARRANTY OF ANY KIND, EXPRESS OR IMPLIED, WITH REGARDS TO ANY INFORMATION CONTAINED IN THIS DOCUMENT, INCLUDING, BUT NOT LIMITED TO, THE IMPLIED WARRANTIES OF MERCHANTABILITY, FITNESS FOR A PARTICULAR PURPOSE OR NON-INFRINGEMENT OF THIRD PARTY INTELLECTUAL PROPERTY RIGHTS (AND THEIR EQUIVALENTS UNDER THE LAWS OF ANY JURISDICTION).
2. The Information contained herein is for informational purpose only and is provided only to illustrate the operation of Diodes' products described herein and application examples. Diodes does not assume any liability arising out of the application or use of this document or any product described herein. This document is intended for skilled and technically trained engineering customers and users who design with Diodes' products. Diodes' products may be used to facilitate safety-related applications; however, in all instances customers and users are responsible for (a) selecting the appropriate Diodes products for their applications, (b) evaluating the suitability of Diodes' products for their intended applications, (c) ensuring their applications, which incorporate Diodes' products, comply the applicable legal and regulatory requirements as well as safety and functional-safety related standards, and (d) ensuring they design with appropriate safeguards (including testing, validation, quality control techniques, redundancy, malfunction prevention, and appropriate treatment for aging degradation) to minimize the risks associated with their applications.
3. Diodes assumes no liability for any application-related information, support, assistance or feedback that may be provided by Diodes from time to time. Any customer or user of this document or products described herein will assume all risks and liabilities associated with such use, and will hold Diodes and all companies whose products are represented herein or on Diodes' websites, harmless against all damages and liabilities.
4. Products described herein may be covered by one or more United States, international or foreign patents and pending patent applications. Product names and markings noted herein may also be covered by one or more United States, international or foreign trademarks and trademark applications. Diodes does not convey any license under any of its intellectual property rights or the rights of any third parties (including third parties whose products and services may be described in this document or on Diodes' website) under this document.
5. Diodes' products are provided subject to Diodes' Standard Terms and Conditions of Sale (<https://www.diodes.com/about/company/terms-and-conditions/terms-and-conditions-of-sales/>) or other applicable terms. This document does not alter or expand the applicable warranties provided by Diodes. Diodes does not warrant or accept any liability whatsoever in respect of any products purchased through unauthorized sales channel.
6. Diodes' products and technology may not be used for or incorporated into any products or systems whose manufacture, use or sale is prohibited under any applicable laws and regulations. Should customers or users use Diodes' products in contravention of any applicable laws or regulations, or for any unintended or unauthorized application, customers and users will (a) be solely responsible for any damages, losses or penalties arising in connection therewith or as a result thereof, and (b) indemnify and hold Diodes and its representatives and agents harmless against any and all claims, damages, expenses, and attorney fees arising out of, directly or indirectly, any claim relating to any noncompliance with the applicable laws and regulations, as well as any unintended or unauthorized application.
7. While efforts have been made to ensure the information contained in this document is accurate, complete and current, it may contain technical inaccuracies, omissions and typographical errors. Diodes does not warrant that information contained in this document is error-free and Diodes is under no obligation to update or otherwise correct this information. Notwithstanding the foregoing, Diodes reserves the right to make modifications, enhancements, improvements, corrections or other changes without further notice to this document and any product described herein. This document is written in English but may be translated into multiple languages for reference. Only the English version of this document is the final and determinative format released by Diodes.
8. Any unauthorized copying, modification, distribution, transmission, display or other use of this document (or any portion hereof) is prohibited. Diodes assumes no responsibility for any losses incurred by the customers or users or any third parties arising from any such unauthorized use.
9. This Notice may be periodically updated with the most recent version available at <https://www.diodes.com/about/company/terms-and-conditions/important-notice>

The Diodes logo is a registered trademark of Diodes Incorporated in the United States and other countries.  
All other trademarks are the property of their respective owners.  
© 2023 Diodes Incorporated. All Rights Reserved.

[www.diodes.com](http://www.diodes.com)

## Looking for pricing, stock, or lifecycle information?

Click below to explore more details on WIN SOURCE:

-  [View BCR402UW6-7 on WIN SOURCE](#)
-  [Diodes Incorporated Information](#)

## Optimize Your Supply Chain with WIN SOURCE Solutions

-  Global Sourcing Solution
-  Obsolete Management
-  Cost Control Management
-  Shortage Management
-  Alternative Solution
-  Excess Inventory Management