



**THE DATASHEET OF  
AT28C040-20BI**



## Features

- Read Access Time - 200 ns
- Automatic Page Write Operation
  - Internal Address and Data Latches for 256 Bytes
  - Internal Control Timer
- Fast Write Cycle Time
  - Page Write Cycle Time - 10 ms Maximum
  - 1 to 256 Byte Page Write Operation
- Low Power Dissipation
  - 80 mA Active Current
- Hardware and Software Data Protection
- DATA Polling for End of Write Detection
- High Reliability CMOS Technology
  - Endurance: 10,000 Cycles
  - Data Retention: 10 Years
- Single 5V ± 10% Supply
- CMOS and TTL Compatible Inputs and Outputs
- JEDEC Approved Byte-Wide Pinout

## Description

The AT28C040 is a high-performance electrically erasable and programmable read only memory (EEPROM). Its 4 megabits of memory is organized as 524,288 words by 8 bits. Manufactured with Atmel's advanced nonvolatile CMOS technology, the device offers access times to 200 ns with power dissipation of just 440 mW.

(continued)

## Pin Configurations

Pin Name	Function
A0 - A18	Addresses
$\overline{CE}$	Chip Enable
$\overline{OE}$	Output Enable
$\overline{WE}$	Write Enable
I/O0 - I/O7	Data Inputs/Outputs
NC	No Connect

LCC  
Top View

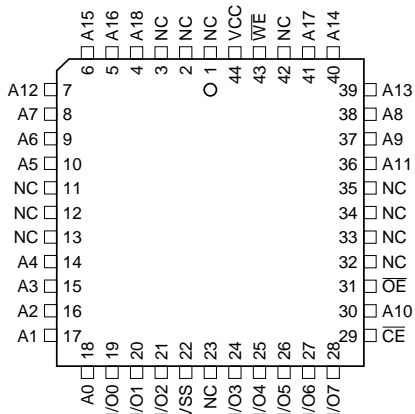

SIDE BRAZE,  
FLATPACK  
Top View

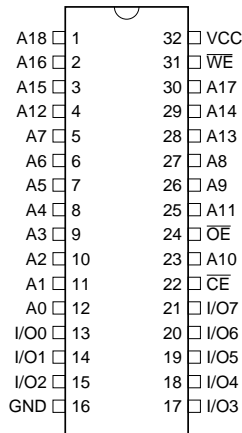

# 4-Megabit (512K x 8) Paged Parallel EEPROMs

## AT28C040



The AT28C040 is accessed like a static RAM for the read or write cycle without the need for external components. The device contains a 256-byte page register to allow writing of up to 256 bytes simultaneously. During a write cycle, the address and 1 to 256 bytes of data are internally latched, freeing the address and data bus for other operations. Following the initiation of a write cycle, the device will automatically write the latched data using an internal control timer. The end of a write cycle can be detected by

$\overline{\text{DATA POLLING}}$  of I/O7. Once the end of a write cycle has been detected, a new access for a read or write can begin. Atmel's AT28C040 has additional features to ensure high quality and manufacturability. The device utilizes internal error correction for extended endurance and improved data retention characteristics. An optional software data protection mechanism is available to guard against inadvertent writes. The device also includes an extra 256 bytes of EEPROM for device identification or tracking.

## Block Diagram

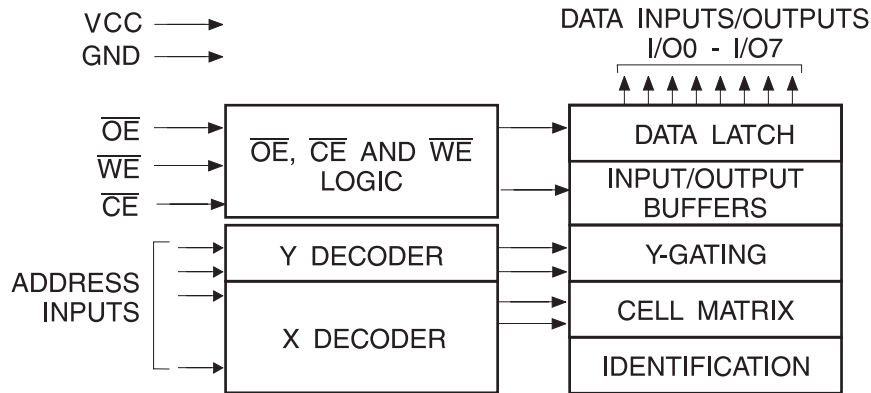

## Absolute Maximum Ratings\*

Temperature Under Bias .....	-55°C to +125°C
Storage Temperature .....	-65°C to +150°C
All Input Voltages (including NC pins) with Respect to Ground .....	-0.6V to +6.25V
All Output Voltages with Respect to Ground .....	-0.6V to $V_{CC} + 0.6V$
Voltage on $\overline{\text{OE}}$ and A9 with Respect to Ground .....	-0.6V to +13.5V

\*NOTICE: Stresses beyond those listed under "Absolute Maximum Ratings" may cause permanent damage to the device. This is a stress rating only and functional operation of the device at these or any other conditions beyond those indicated in the operational sections of this specification is not implied. Exposure to absolute maximum rating conditions for extended periods may affect device reliability.

## Device Operation

**READ:** The AT28C040 is accessed like a static RAM. When  $\overline{CE}$  and  $\overline{OE}$  are low and  $\overline{WE}$  is high, the data stored at the memory location determined by the address pins is asserted on the outputs. The outputs are put in the high impedance state when either  $\overline{CE}$  or  $\overline{OE}$  is high. This dual-line control gives designers flexibility in preventing bus contention in their systems.

**BYTE WRITE:** A low pulse on the  $\overline{WE}$  or  $\overline{CE}$  input with  $\overline{CE}$  or  $\overline{WE}$  low (respectively) and  $\overline{OE}$  high initiates a write cycle. The address is latched on the falling edge of  $\overline{CE}$  or  $\overline{WE}$ , whichever occurs last. The data is latched by the first rising edge of  $\overline{CE}$  or  $\overline{WE}$ . Once a byte write has been started, it will automatically time itself to completion. Once a programming operation has been initiated and for the duration of  $t_{WC}$ , a read operation will effectively be a polling operation.

**PAGE WRITE:** The page write operation of the AT28C040 allows 1 to 256 bytes of data to be written into the device during a single internal programming period. A page write operation is initiated in the same manner as a byte write; the first byte written can then be followed by 1 to 255 additional bytes. Each successive byte must be written within 150  $\mu$ s ( $t_{BLC}$ ) of the previous byte. If the  $t_{BLC}$  limit is exceeded, the AT28C040 will cease accepting data and commence the internal programming operation. All bytes during a page write operation must reside on the same page as defined by the state of the A8 - A18 inputs. For each  $\overline{WE}$  high to low transition during the page write operation, A8 - A18 must be the same.

The A0 to A7 inputs specify which bytes within the page are to be written. The bytes may be loaded in any order and may be altered within the same load period. Only bytes which are specified for writing will be written; unnecessary cycling of other bytes within the page does not occur.

**DATA POLLING:** The AT28C040 features  $\overline{DATA}$  Polling to indicate the end of a write cycle. During a byte or page write cycle an attempted read of the last byte written will result in the complement of the written data to be presented on I/O7. Once the write cycle has been completed, true data is valid on all outputs, and the next write cycle may begin.  $\overline{DATA}$  Polling may begin at anytime during the write cycle.

**TOGGLE BIT:** In addition to  $\overline{DATA}$  Polling, the AT28C040 provides another method for determining the end of a write cycle. During the write operation, successive attempts to read data from the device will result in I/O6 toggling between one and zero. Once the write has completed, I/O6 will stop toggling and valid data will be read. Reading the toggle bit may begin at any time during the write cycle.

**DATA PROTECTION:** If precautions are not taken, inadvertent writes may occur during transitions of the host system power supply. Atmel has incorporated both hardware

and software features that will protect the memory against inadvertent writes.

**HARDWARE PROTECTION:** Hardware features protect against inadvertent writes to the AT28C040 in the following ways: (a)  $V_{CC}$  sense - if  $V_{CC}$  is below 3.8V (typical) the write function is inhibited; (b)  $V_{CC}$  power-on delay - once  $V_{CC}$  has reached 3.8V the device will automatically time out 5 ms (typical) before allowing a write; (c) write inhibit - holding any one of  $\overline{OE}$  low,  $\overline{CE}$  high or  $\overline{WE}$  high inhibits write cycles; (d) noise filter - pulses of less than 15 ns (typical) on the  $\overline{WE}$  or  $\overline{CE}$  inputs will not initiate a write cycle.

**SOFTWARE DATA PROTECTION:** A software controlled data protection feature has been implemented on the AT28C040. When enabled, the software data protection (SDP), will prevent inadvertent writes. The SDP feature may be enabled or disabled by the user; the AT28C040 is shipped from Atmel with SDP disabled.

SDP is enabled when the host system issues a series of three write commands; three specific bytes of data are written to three specific addresses (refer to Software Data Protection Algorithm). After writing the 3-byte command sequence and after  $t_{WC}$ , the entire AT28C040 will be protected against inadvertent write operations. It should be noted that once protected, the host can still perform a byte or page write to the AT28C040. To do so, the same 3-byte command sequence used to enable SDP must precede the data to be written.

Once set, SDP will remain active unless the disable command sequence is issued. Power transitions do not disable SDP, and SDP will protect the AT28C040 during power-up and power-down conditions. All command sequences must conform to the page write timing specifications. The data in the enable and disable command sequences is not written to the device, and the memory addresses used in the sequence may be written with data in either a byte or page write operation.

After setting SDP, any attempt to write to the device without the 3-byte command sequence will start the internal write timers. No data will be written to the device; however, for the duration of  $t_{WC}$ , read operations will effectively be polling operations.

**DEVICE IDENTIFICATION:** An extra 256 bytes of EEPROM memory are available to the user for device identification. By raising A9 to 12V  $\pm$  0.5V and using address locations 7FF80H to 7FFFFH, the bytes may be written to or read from in the same manner as the regular memory array.

**OPTIONAL CHIP ERASE MODE:** The entire device can be erased using a 6-byte software erase code. Please see Software Chip Erase application note for details.



## DC and AC Operating Range

		AT28C040-20		AT28C040-25	
		Operation		Operation	
		Read	Program	Read	Program
Operating Temperature (Case)	Commercial	0°C - 70°C	0°C - 70°C	0°C - 70°C	0°C - 70°C
	Industrial	-40°C - 85°C	-40°C - 85°C	-40°C - 85°C	-40°C - 85°C
	Extended	-55°C - 125°C	-40°C - 85°C	-55°C - 125°C	-40°C - 85°C
V <sub>CC</sub> Power Supply		5V ± 10%	5V ± 10%	5V ± 10%	5V ± 10%

## Operating Modes

Mode	$\overline{CE}$	$\overline{OE}$	$\overline{WE}$	I/O
Read	V <sub>IL</sub>	V <sub>IL</sub>	V <sub>IH</sub>	D <sub>OUT</sub>
Write <sup>(2)</sup>	V <sub>IL</sub>	V <sub>IH</sub>	V <sub>IL</sub>	D <sub>IN</sub>
Standby/Write Inhibit	V <sub>IH</sub>	X <sup>(1)</sup>	X	High Z
Write Inhibit	X	X	V <sub>IH</sub>	
Write Inhibit	X	V <sub>IL</sub>	X	
Output Disable	X	V <sub>IH</sub>	X	High Z

Notes: 1. X can be V<sub>IL</sub> or V<sub>IH</sub>.

2. Refer to AC Programming Waveforms.

## DC Characteristics

Symbol	Parameter	Condition	Min	Max	Units
I <sub>LI</sub>	Input Load Current	V <sub>IN</sub> = 0V to V <sub>CC</sub> + 1V		10	μA
I <sub>LO</sub>	Output Leakage Current	V <sub>I/O</sub> = 0V to V <sub>CC</sub>		10	μA
I <sub>SB1</sub>	V <sub>CC</sub> Standby Current CMOS	$\overline{CE} = V_{CC} - 0.3V$ to V <sub>CC</sub> + 1V		3	mA
I <sub>SB2</sub>	V <sub>CC</sub> Standby Current TTL	$\overline{CE} = 2.0V$ to V <sub>CC</sub> + 1V		3	mA
I <sub>CC</sub>	V <sub>CC</sub> Active Current	f = 5 MHz; I <sub>OUT</sub> = 0 mA		80	mA
V <sub>IL</sub>	Input Low Voltage			0.8	V
V <sub>IH</sub>	Input High Voltage		2.0		V
V <sub>OL</sub>	Output Low Voltage	I <sub>OL</sub> = 2.1 mA		0.45	V
V <sub>OH1</sub>	Output High Voltage	I <sub>OH</sub> = -400 μA	2.4		V
V <sub>OH2</sub>	Output High Voltage CMOS	I <sub>OH</sub> = -100 μA; V <sub>CC</sub> = 4.5V	4.2		V

## AC Read Characteristics

Symbol	Parameter	AT28C040-20		AT28C040-25		Units
		Min	Max	Min	Max	
$t_{ACC}$	Address to Output Delay		200		250	ns
$t_{CE}^{(1)}$	$\overline{CE}$ to Output Delay		200		250	ns
$t_{OE}^{(2)}$	$\overline{OE}$ to Output Delay	0	55	0	55	ns
$t_{DF}^{(3)(4)}$	$\overline{CE}$ or $\overline{OE}$ to Output Float	0	55	0	55	ns
$t_{OH}$	Output Hold from $\overline{OE}$ , $\overline{CE}$ or Address, whichever occurred first	0		0		ns

## AC Read Waveforms<sup>(1)(2)(3)(4)</sup>

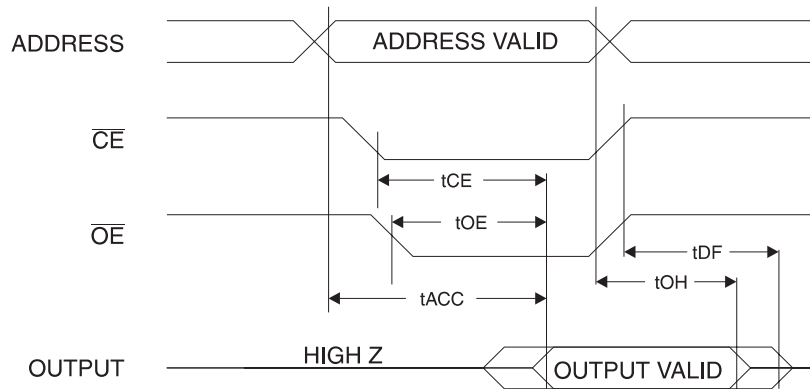

- Note:
- $\overline{CE}$  May be delayed up to  $t_{ACC} - t_{CE}$  after the address transition without impact on  $t_{ACC}$ .
  - $\overline{OE}$  may be delayed up to  $t_{CE} - t_{OE}$  after the falling edge of  $\overline{CE}$  without impact on  $t_{CE}$  or by  $t_{ACC} - t_{OE}$  after an address change without impact on  $t_{ACC}$ .
  - $t_{DF}$  is specified from  $\overline{OE}$  or  $\overline{CE}$ , whichever occurs first ( $C_L = 5 \text{ pF}$ ).
  - This parameter is characterized and is not 100% tested.

## Input Test Waveforms and Measurement Level

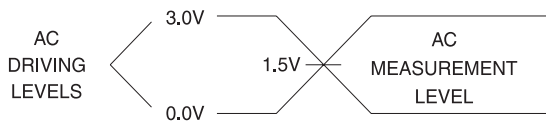

$t_R, t_F < 5 \text{ ns}$

## Output Test Load

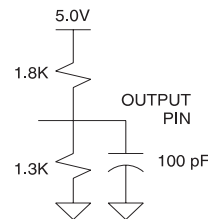

## Pin Capacitance

$f = 1 \text{ MHz}, T = 25^\circ\text{C}^{(1)}$

Symbol	Typ	Max	Units	Conditions
$C_{IN}$	4	10	pF	$V_{IN} = 0V$
$C_{OUT}$	8	12	pF	$V_{OUT} = 0V$

- Note:
- This parameter is characterized and is not 100% tested.

## AC Write Characteristics

Symbol	Parameter	Min	Max	Units
$t_{AS}, t_{OES}$	Address, $\overline{OE}$ Set-up Time	0		ns
$t_{AH}$	Address Hold Time	50		ns
$t_{CS}$	Chip Select Set-up Time	0		ns
$t_{CH}$	Chip Select Hold Time	0		ns
$t_{WP}$	Write Pulse Width ( $\overline{WE}$ or $\overline{CE}$ )	100		ns
$t_{DS}$	Data Set-up Time	50		ns
$t_{DH}, t_{OEH}$	Data, $\overline{OE}$ Hold Time	0		ns

## AC Write Waveforms

### $\overline{WE}$ Controlled

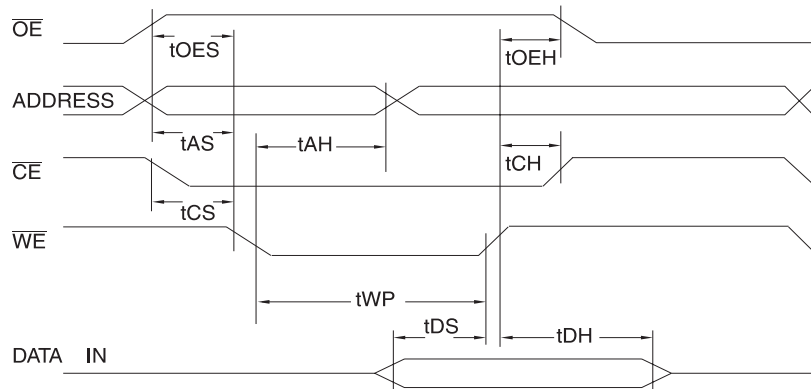

### $\overline{CE}$ Controlled

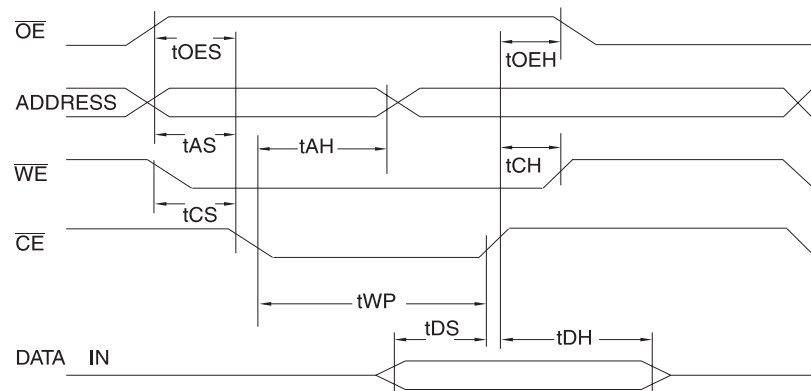

Page Mode Characteristics

Symbol	Parameter	Min	Max	Units
$t_{WC}$	Write Cycle Time		10	ms
$t_{AS}$	Address Set-up Time	0		ns
$t_{AH}$	Address Hold Time	50		ns
$t_{DS}$	Data Set-up Time	50		ns
$t_{DH}$	Data Hold Time	0		ns
$t_{WPH}$	Write Pulse Width High	100		ns
$t_{BLC}$	Byte Load Cycle Time		150	$\mu$ s
$t_{WPH}$	Write Pulse Width High	50		ns

Page Mode Write Waveforms<sup>(1)(2)</sup>

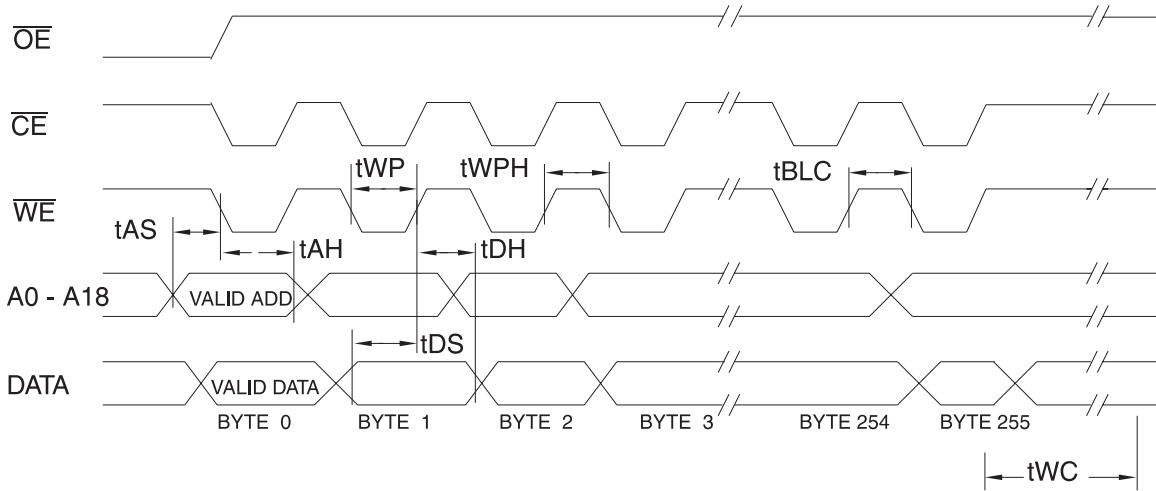

- Notes:
1. A8 through A18 must specify the page address during each high to low transition of  $\overline{WE}$  (or  $\overline{CE}$ ).
  2.  $\overline{OE}$  must be high only when  $\overline{WE}$  and  $\overline{CE}$  are both low.

## Software Data Protection Enable Algorithm<sup>(1)</sup>

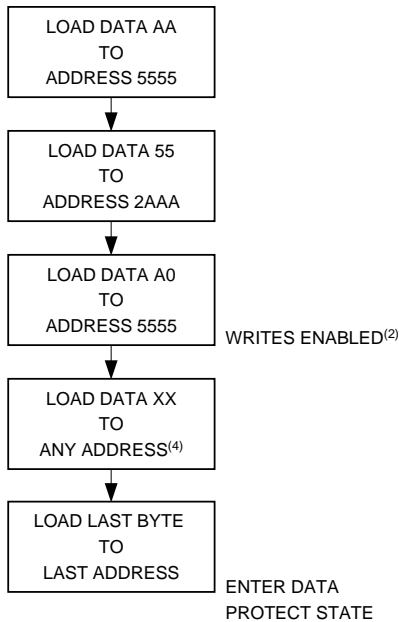

## Software Data Protection Disable Algorithm<sup>(1)</sup>

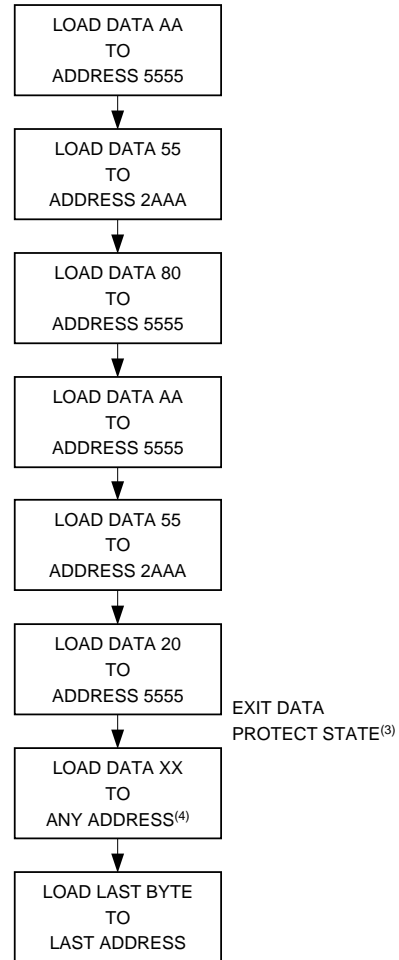

- Notes:
1. Data Format: I/O7 - I/O0 (Hex); Address Format: A14 - A0 (Hex).
  2. Write Protect state will be activated at end of write even if no other data is loaded.
  3. Write Protect state will be deactivated at end of write period even if no other data is loaded.
  4. 1 to 256 bytes of data are loaded.

## Software Protected Program Cycle Waveform<sup>(1)(2)(3)</sup>

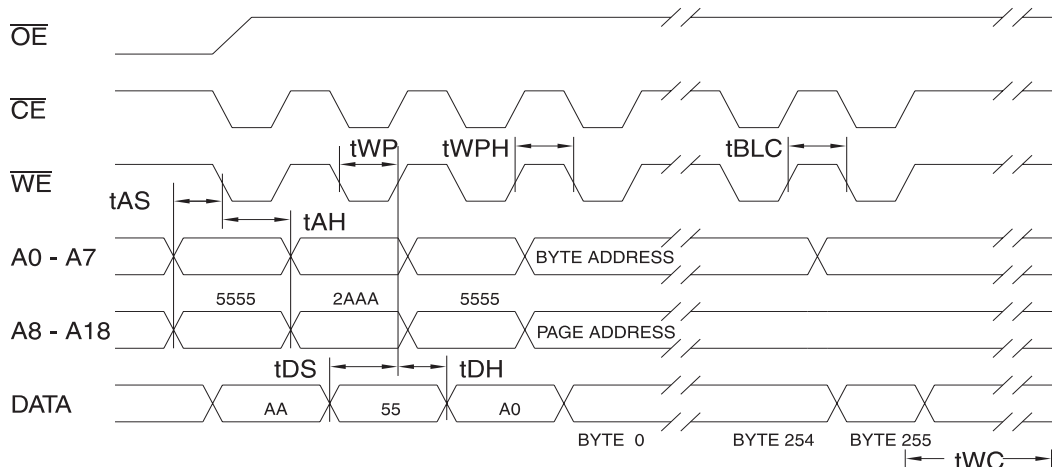

- Notes:
1. A0 - A14 must conform to the addressing sequence for the first 3 bytes as shown above.
  2. After the command sequence has been issued and a page write operation follows, the page address inputs (A8 - A18) must be the same for each high to low transition of  $\overline{WE}$  (or  $\overline{CE}$ ).
  3.  $\overline{OE}$  must be high only when  $\overline{WE}$  and  $\overline{CE}$  are both low.

## Data Polling Characteristics<sup>(1)</sup>

Symbol	Parameter	Min	Typ	Max	Units
$t_{DH}$	Data Hold Time	10			ns
$t_{OE\overline{H}}$	$\overline{OE}$ Hold Time	10			ns
$t_{OE}$	$\overline{OE}$ to Output Delay <sup>(2)</sup>				ns
$t_{WR}$	Write Recovery Time	0			ns

Notes: 1. These parameters are characterized and not 100% tested.  
 2. See AC Read Characteristics.

## Data Polling Waveforms

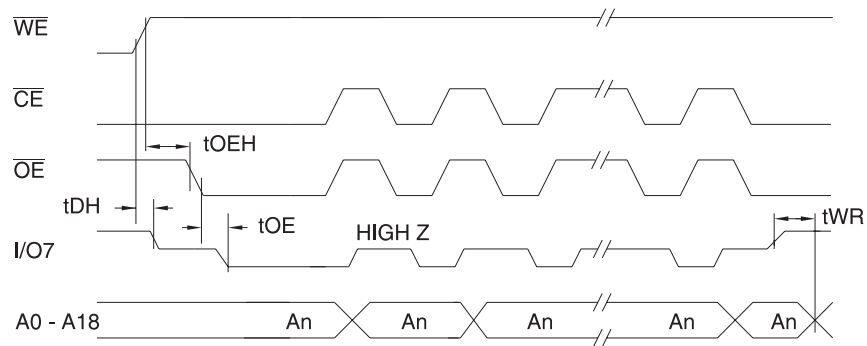

## Toggle Bit Characteristics<sup>(1)</sup>

Symbol	Parameter	Min	Typ	Max	Units
$t_{DH}$	Data Hold Time	10			ns
$t_{OE\overline{H}}$	$\overline{OE}$ Hold Time	10			ns
$t_{OE}$	$\overline{OE}$ to Output Delay <sup>(2)</sup>				ns
$t_{OEHP}$	$\overline{OE}$ High Pulse	150			ns
$t_{WR}$	Write Recovery Time	0			ns

Notes: 1. These parameters are characterized and not 100% tested.  
 2. See AC Read Characteristics.

## Toggle Bit Waveforms<sup>(1)(2)(3)</sup>

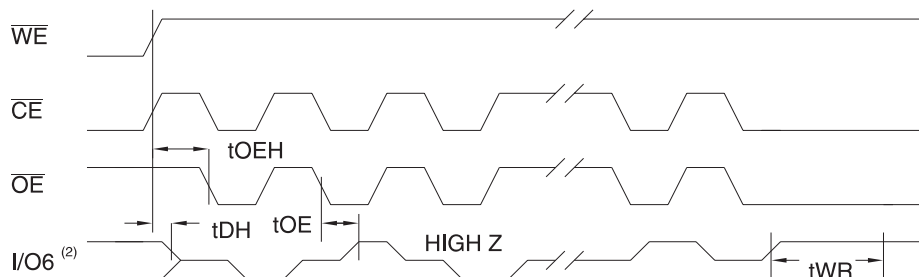

Notes: 1. Toggling either OE or CE or both OE and CE will operate toggle bit.  
 2. Beginning and ending state of I/O6 will vary.  
 3. Any address location may be used but the address should not vary.



## Ordering Information<sup>(1)</sup>

t <sub>ACC</sub> (ns)	I <sub>CC</sub> (mA)		Ordering Code	Package	Operation Range
	Active	Standby			
200	80	3	AT28C040-20BC	32B	Commercial (0° to 70°C)
			AT28C040-20FC	32F	
			AT28C040-20LC	44L	
	80	3	AT28C040-20BI	32B	Industrial (-40° to 85°C)
			AT28C040-20FI	32F	
			AT28C040-20LI	44L	
	80	3	AT28C040-20BI SL703	32B	Extended (See DC and AC Operating Range Table)
			AT28C040-20FI SL703	32F	
			AT28C040-20LI SL703	44L	
250	80	3	AT28C040-25BC	32B	Commercial (0° to 70°C)
			AT28C040-25FC	32F	
			AT28C040-25LC	44L	
	80	3	AT28C040-25BI	32B	Industrial (-40° to 85°C)
			AT28C040-25FI	32F	
			AT28C040-25LI	44L	
	80	3	AT28C040-25BI SL703	32B	Extended (See DC and AC Operating Range Table)
			AT28C040-25FI SL703	32F	
			AT28C040-25LI SL703	44L	

Note: 1. See Valid Part Numbers.

## Valid Part Numbers

The following table lists standard Atmel products that can be ordered.

Device Numbers	Speed	Package and Temperature Combinations
AT28C040	20	BC, BI, FC, FI, LC, LI, BI SL703, FI SL703, LI SL703
AT28C040	25	BC, BI, FC, FI, LC, LI, BI SL703, FI SL703, LI SL703

## Die Products

Reference Section: Parallel EEPROM Die Products

Package Type	
<b>32B</b>	32-Lead, 0.600" Wide, Ceramic Side Braze Dual Inline (Side Braze)
<b>32F</b>	32-Lead, Non-Windowed, Ceramic Bottom-Brazed Flat Package (Flatpack)
<b>44L</b>	44-Pad, Non-Windowed, Ceramic Leadless Chip Carrier (LCC)
Options	
<b>Blank</b>	Standard Device: Endurance = 10K Write Cycles; Write Time = 10 ms

## Packaging Information

**32B**, 32-Lead, 0.600" Wide, Ceramic Side Braze Dual Inline (Side Braze)  
 Dimensions in Inches and (Millimeters)

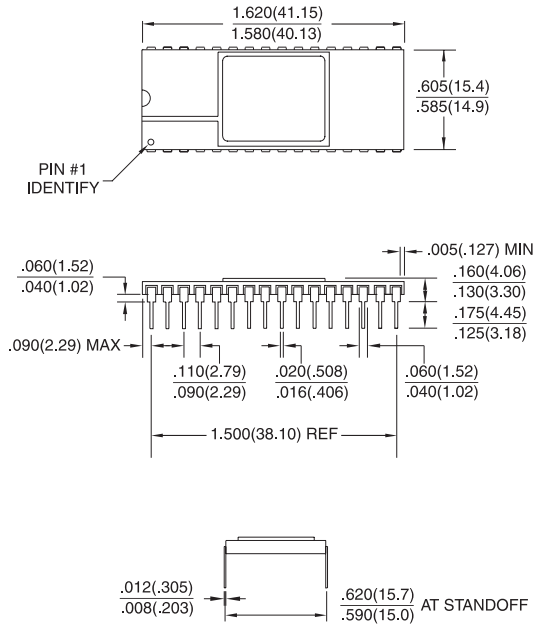

**32F**, 32-Lead, Non-Windowed, Ceramic Bottom-Brazed Flat Package (Flatpack)  
 Dimension in Inches and (Millimeters)  
 JEDEC OUTLINE MO-115

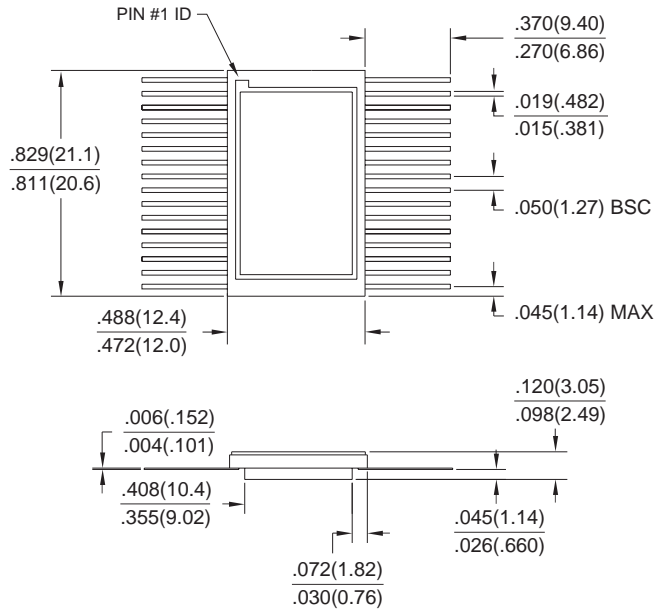

**44L**, 44-Pad, Non-Windowed, Ceramic Leadless Chip Carrier (LCC)  
 Dimensions in Inches and (Millimeters)\*  
 MIL-STD-1835 C-5

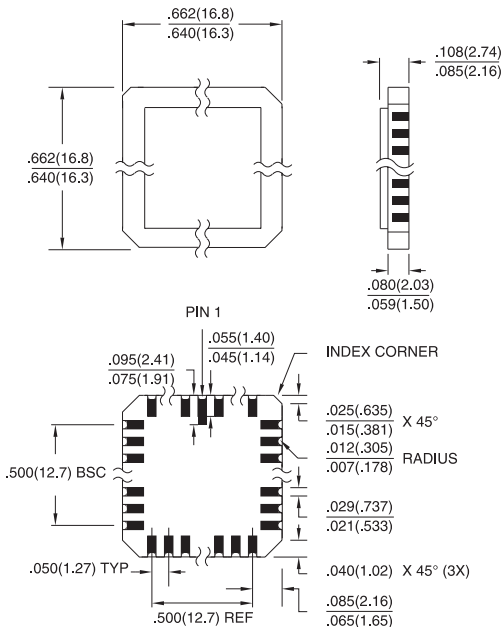

\*Ceramic lid standard unless specified.



## Atmel Headquarters

**Corporate Headquarters**  
2325 Orchard Parkway  
San Jose, CA 95131  
TEL (408) 441-0311  
FAX (408) 487-2600

### Europe

Atmel U.K., Ltd.  
Coliseum Business Centre  
Riverside Way  
Camberley, Surrey GU15 3YL  
England  
TEL (44) 1276-686677  
FAX (44) 1276-686697

### Asia

Atmel Asia, Ltd.  
Room 1219  
Chinachem Golden Plaza  
77 Mody Road  
Tsimshatsui East  
Kowloon, Hong Kong  
TEL (852) 27219778  
FAX (852) 27221369

### Japan

Atmel Japan K.K.  
Tonetsu Shinkawa Bldg., 9F  
1-24-8 Shinkawa  
Chuo-ku, Tokyo 104-0033  
Japan  
TEL (81) 3-3523-3551  
FAX (81) 3-3523-7581

## Atmel Operations

**Atmel Colorado Springs**  
1150 E. Cheyenne Mtn. Blvd.  
Colorado Springs, CO 80906  
TEL (719) 576-3300  
FAX (719) 540-1759

### Atmel Rousset

Zone Industrielle  
13106 Rousset Cedex, France  
TEL (33) 4 42 53 60 00  
FAX (33) 4 42 53 60 01

---

### **Fax-on-Demand**

North America:  
1-(800) 292-8635  
International:  
1-(408) 441-0732

### **e-mail**

[literature@atmel.com](mailto:literature@atmel.com)

### **Web Site**

<http://www.atmel.com>

### **BBS**

1-(408) 436-4309

### © Atmel Corporation 1998.

Atmel Corporation makes no warranty for the use of its products, other than those expressly contained in the Company's standard warranty which is detailed in Atmel's Terms and Conditions located on the Company's website. The Company assumes no responsibility for any errors which may appear in this document, reserves the right to change devices or specifications detailed herein at any time without notice, and does not make any commitment to update the information contained herein. No licenses to patents or other intellectual property of Atmel are granted by the Company in connection with the sale of Atmel products, expressly or by implication. Atmel's products are not authorized for use as critical components in life support devices or systems.

Marks bearing ® and/or ™ are registered trademarks and trademarks of Atmel Corporation.

Terms and product names in this document may be trademarks of others.



Printed on recycled paper.

0542B-10/98/xM

## Looking for pricing, stock, or lifecycle information?

Click below to explore more details on WIN SOURCE:

- ⊖ [View AT28C040-20BI](#) on WIN SOURCE
- ⊖ [Microchip Technology](#) Information

## Optimize Your Supply Chain with WIN SOURCE Solutions

- ✓ Global Sourcing Solution
- ✓ Obsolete Management
- ✓ Cost Control Management
- ✓ Shortage Management
- ✓ Alternative Solution
- ✓ Excess Inventory Management