



**THE DATASHEET OF  
AT27BV256-12JC**



## Features

- Fast Read Access Time - 70 ns
- Dual Voltage Range Operation
  - Unregulated Battery Power Supply Range, 2.7V to 3.6V
  - or Standard 5V  $\pm$  10% Supply Range
- Pin Compatible with JEDEC Standard AT27C256R
- Low Power CMOS Operation
  - 20  $\mu$ A max. (less than 1  $\mu$ A typical) Standby for  $V_{CC} = 3.6V$
  - 29 mW max. Active at 5 MHz for  $V_{CC} = 3.6V$
- JEDEC Standard Surface Mount Packages
  - 32-Lead PLCC
  - 28-Lead 330-mil SOIC
  - 28-Lead TSOP
- High Reliability CMOS Technology
  - 2,000V ESD Protection
  - 200 mA Latchup Immunity
- Rapid™ Programming Algorithm - 100  $\mu$ s/byte (typical)
- CMOS and TTL Compatible Inputs and Outputs
  - JEDEC Standard for LVTTTL and LVBO
- Integrated Product Identification Code
- Commercial and Industrial Temperature Ranges

## Description

The AT27BV256 is a high performance, low power, low voltage 262,144-bit one-time programmable read only memory (OTP EPROM) organized as 32K by 8 bits. It requires only one supply in the range of 2.7V to 3.6V in normal read mode operation, making it ideal for fast, portable systems using either regulated or unregulated battery power.

*(continued)*

## Pin Configurations

Pin Name	Function
A0 - A14	Addresses
O0 - O7	Outputs
$\overline{CE}$	Chip Enable
$\overline{OE}$	Output Enable
NC	No Connect

PLCC Top View

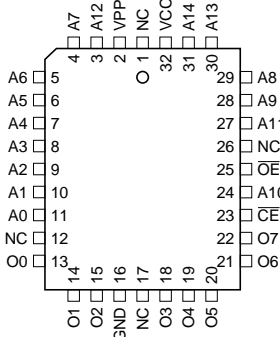

Note: PLCC package pins 1 and 17 are DON'T CONNECT.

SOIC Top View

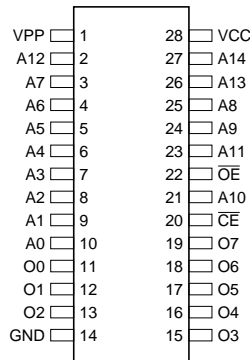

TSOP Top View

Type 1

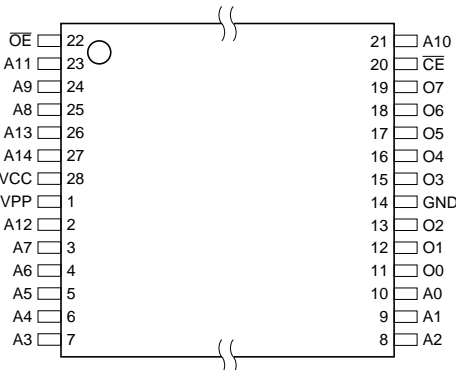

**256K (32K x 8)**  
**Unregulated**  
**Battery-Voltage™**  
**High Speed**  
**OTP EPROM**

**AT27BV256**



Atmel's innovative design techniques provide fast speeds that rival 5V parts while keeping the low power consumption of a 3V supply. At  $V_{CC} = 2.7V$ , any word can be accessed in less than 70 ns. With a typical power dissipation of only 18 mW at 5 MHz and  $V_{CC} = 3V$ , the AT27BV256 consumes less than one fifth the power of a standard 5V EPROM.

Standby mode supply current is typically less than 1  $\mu A$  at 3V. The AT27BV256 simplifies system design and stretches battery lifetime even further by eliminating the need for power supply regulation.

The AT27BV256 is available in industry standard JEDEC-approved one-time programmable (OTP) plastic PLCC, SOIC and TSOP packages. All devices feature two-line control ( $\overline{CE}$ ,  $\overline{OE}$ ) to give designers the flexibility to prevent bus contention.

The AT27BV256 operating with  $V_{CC}$  at 3.0V produces TTL level outputs that are compatible with standard TTL logic devices operating at  $V_{CC} = 5.0V$ . At  $V_{CC} = 2.7V$ , the part is compatible with JEDEC approved low voltage battery operation (LVBO) interface specifications. The device is also capable of standard 5-volt operation making it ideally suited for dual supply range systems or card products that are pluggable in both 3-volt and 5-volt hosts.

Atmel's AT27BV256 has additional features to ensure high quality and efficient production use. The Rapid™ Program-

ming Algorithm reduces the time required to program the part and guarantees reliable programming. Programming time is typically only 100  $\mu s$ /byte. The Integrated Product Identification Code electronically identifies the device and manufacturer. This feature is used by industry standard programming equipment to select the proper programming algorithms and voltages. The AT27BV256 programs exactly the same way as a standard 5V AT27C256R and uses the same programming equipment.

## System Considerations

Switching between active and standby conditions via the Chip Enable pin may produce transient voltage excursions. Unless accommodated by the system design, these transients may exceed data sheet limits, resulting in device non-conformance. At a minimum, a 0.1  $\mu F$  high frequency, low inherent inductance, ceramic capacitor should be utilized for each device. This capacitor should be connected between the  $V_{CC}$  and Ground terminals of the device, as close to the device as possible. Additionally, to stabilize the supply voltage level on printed circuit boards with large EPROM arrays, a 4.7  $\mu F$  bulk electrolytic capacitor should be utilized, again connected between the  $V_{CC}$  and Ground terminals. This capacitor should be positioned as close as possible to the point where the power supply is connected to the array.

## Block Diagram

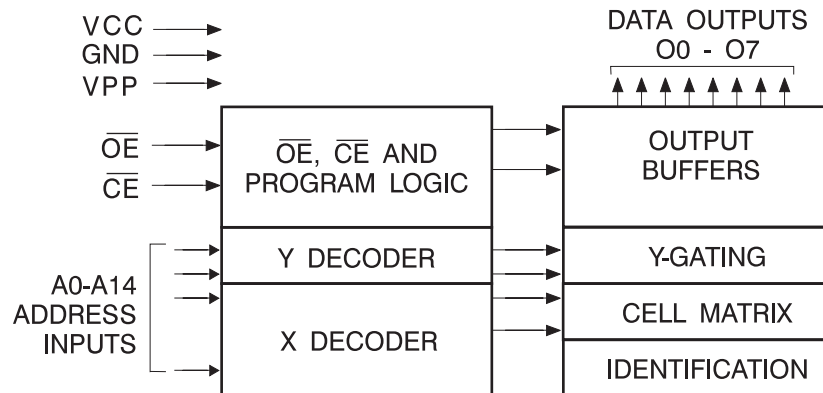

## Absolute Maximum Ratings\*

Temperature Under Bias .....	-40°C to +85°C
Storage Temperature .....	-65°C to +125°C
Voltage on Any Pin with Respect to Ground .....	-2.0V to +7.0V <sup>(1)</sup>
Voltage on A9 with Respect to Ground .....	-2.0V to +14.0V <sup>(1)</sup>
V <sub>PP</sub> Supply Voltage with Respect to Ground .....	-2.0V to +14.0V <sup>(1)</sup>

\*NOTICE: Stresses beyond those listed under “Absolute Maximum Ratings” may cause permanent damage to the device. This is a stress rating only and functional operation of the device at these or any other conditions beyond those indicated in the operational sections of this specification is not implied. Exposure to absolute maximum rating conditions for extended periods may affect device reliability

Note: 1. Minimum voltage is -0.6V dc which may undershoot to -2.0V for pulses of less than 20 ns. Maximum output pin voltage is V<sub>CC</sub> + 0.75V dc which may be exceeded if certain precautions are observed (consult application notes) and which may overshoot to +7.0V for pulses of less than 20 ns.

## Operating Modes

Mode \ Pin	$\overline{CE}$	$\overline{OE}$	Ai	V <sub>PP</sub>	V <sub>CC</sub>	Outputs
Read <sup>(2)</sup>	V <sub>IL</sub>	V <sub>IL</sub>	Ai	V <sub>CC</sub>	V <sub>CC</sub> <sup>(2)</sup>	D <sub>OUT</sub>
Output Disable <sup>(2)</sup>	V <sub>IL</sub>	V <sub>IH</sub>	X <sup>(1)</sup>	V <sub>CC</sub>	V <sub>CC</sub> <sup>(2)</sup>	High Z
Standby <sup>(2)</sup>	V <sub>IH</sub>	X	X	V <sub>CC</sub>	V <sub>CC</sub> <sup>(2)</sup>	High Z
Rapid Program <sup>(3)</sup>	V <sub>IL</sub>	V <sub>IH</sub>	Ai	V <sub>PP</sub>	V <sub>CC</sub> <sup>(3)</sup>	D <sub>IN</sub>
PGM Verify <sup>(3)</sup>	X	V <sub>IL</sub>	Ai	V <sub>PP</sub>	V <sub>CC</sub> <sup>(3)</sup>	D <sub>OUT</sub>
Optional PGM Verify <sup>(3)</sup>	V <sub>IL</sub>	V <sub>IL</sub>	Ai	V <sub>CC</sub>	V <sub>CC</sub> <sup>(3)</sup>	D <sub>OUT</sub>
PGM Inhibit <sup>(3)</sup>	V <sub>IH</sub>	V <sub>IH</sub>	X	V <sub>PP</sub>	V <sub>CC</sub> <sup>(3)</sup>	High Z
Product Identification <sup>(3)(5)</sup>	V <sub>IL</sub>	V <sub>IL</sub>	A9 = V <sub>H</sub> <sup>(4)</sup> A0 = V <sub>IH</sub> or V <sub>IL</sub> A1 - A14 = V <sub>IL</sub>	V <sub>CC</sub>	V <sub>CC</sub> <sup>(3)</sup>	Identification Code

- Notes: 1. X can be V<sub>IL</sub> or V<sub>IH</sub>.  
 2. Read, output disable, and standby modes require, 2.7V ≤ V<sub>CC</sub> ≤ 3.6V, or 4.5V ≤ V<sub>CC</sub> ≤ 5.5V.  
 3. Refer to Programming Characteristics. Programming modes require V<sub>CC</sub> = 6.5V.  
 4. V<sub>H</sub> = 12.0 ± 0.5V.  
 5. Two identifier bytes may be selected. All Ai inputs are held low (V<sub>IL</sub>), except A9 which is set to V<sub>H</sub> and A0 which is toggled low (V<sub>IL</sub>) to select the Manufacturers' Identification byte and high (V<sub>IH</sub>) to select the Device Code byte.



## DC and AC Operating Conditions for Read Operation

		AT27BV256			
		-70	-90	-12	-15
Operating Temperature (Case)	Com.	0°C - 70°C	0°C - 70°C	0°C - 70°C	0°C - 70°C
	Ind.	-40°C - 85°C	-40°C - 85°C	-40°C - 85°C	-40°C - 85°C
$V_{CC}$ Power Supply		2.7V to 3.6V	2.7V to 3.6V	2.7V to 3.6V	2.7V to 3.6V
		5V $\pm$ 10%	5V $\pm$ 10%	5V $\pm$ 10%	5V $\pm$ 10%

## DC and Operating Characteristics for Read Operation

Symbol	Parameter	Condition	Min	Max	Units
<b><math>V_{CC} = 2.7V</math> to <math>3.6V</math></b>					
$I_{LI}$	Input Load Current	$V_{IN} = 0V$ to $V_{CC}$		$\pm 1$	$\mu A$
$I_{LO}$	Output Leakage Current	$V_{OUT} = 0V$ to $V_{CC}$		$\pm 5$	$\mu A$
$I_{PP1}^{(2)}$	$V_{PP}^{(1)}$ Read/Standby Current	$V_{PP} = V_{CC}$		10	$\mu A$
$I_{SB}$	$V_{CC}^{(1)}$ Standby Current	$I_{SB1}$ (CMOS), $\overline{CE} = V_{CC} \pm 0.3V$		20	$\mu A$
		$I_{SB2}$ (TTL), $\overline{CE} = 2.0$ to $V_{CC} + 0.5V$		100	$\mu A$
$I_{CC}$	$V_{CC}$ Active Current	$f = 5$ MHz, $I_{OUT} = 0$ mA, $\overline{CE} = V_{IL}$ , $V_{CC} = 3.6V$		8	mA
$V_{IL}$	Input Low Voltage	$V_{CC} = 3.0$ to $3.6V$	-0.6	0.8	V
		$V_{CC} = 2.7$ to $3.6V$	-0.6	$0.2 \times V_{CC}$	V
$V_{IH}$	Input High Voltage	$V_{CC} = 3.0$ to $3.6V$	2.0	$V_{CC} + 0.5$	V
		$V_{CC} = 2.7$ to $3.6V$	$0.7 \times V_{CC}$	$V_{CC} + 0.5$	V
$V_{OL}$	Output Low Voltage	$I_{OL} = 2.0$ mA		0.4	V
		$I_{OL} = 100$ $\mu A$		0.2	V
		$I_{OL} = 20$ $\mu A$		0.1	V
$V_{OH}$	Output High Voltage	$I_{OH} = -2.0$ mA	2.4		V
		$I_{OH} = -100$ $\mu A$	$V_{CC} - 0.2$		V
		$I_{OH} = -20$ $\mu A$	$V_{CC} - 0.1$		V
<b><math>V_{CC} = 4.5V</math> to <math>5.5V</math></b>					
$I_{LI}$	Input Load Current	$V_{IN} = 0V$ to $V_{CC}$		$\pm 1$	$\mu A$
$I_{LO}$	Output Leakage Current	$V_{OUT} = 0V$ to $V_{CC}$		$\pm 5$	$\mu A$
$I_{PP1}^{(2)}$	$V_{PP}^{(1)}$ Read/Standby Current	$V_{PP} = V_{CC}$		10	$\mu A$
$I_{SB}$	$V_{CC}^{(1)}$ Standby Current	$I_{SB1}$ (CMOS), $\overline{CE} = V_{CC} \pm 0.3V$		100	$\mu A$
		$I_{SB2}$ (TTL), $\overline{CE} = 2.0$ to $V_{CC} + 0.5V$		1	mA
$I_{CC}$	$V_{CC}$ Active Current	$f = 5$ MHz, $I_{OUT} = 0$ mA, $\overline{CE} = V_{IL}$		20	mA
$V_{IL}$	Input Low Voltage		-0.6	0.8	V
$V_{IH}$	Input High Voltage		2.0	$V_{CC} + 0.5$	V
$V_{OL}$	Output Low Voltage	$I_{OL} = 2.1$ mA		0.4	V
$V_{OH}$	Output High Voltage	$I_{OH} = -400$ $\mu A$	2.4		V

- Notes: 1.  $V_{CC}$  must be applied simultaneously with or before  $V_{PP}$  and removed simultaneously with or after  $V_{PP}$   
 2.  $V_{PP}$  may be connected directly to  $V_{CC}$ , except during programming. The supply current would then be the sum of  $I_{CC}$  and  $I_{PP}$

## AC Characteristics for Read Operation

$V_{CC} = 2.7V$  to  $3.6V$  and  $4.5V$  to  $5.5V$

Symbol	Parameter	Condition	AT27BV256								Units
			-70		-90		-12		-15		
			Min	Max	Min	Max	Min	Max	Min	Max	
$t_{ACC}^{(3)}$	Address to Output Delay	$\overline{CE} = \overline{OE} = V_{IL}$		70		90		120		150	ns
$t_{CE}^{(2)}$	$\overline{CE}$ to Output Delay	$\overline{OE} = V_{IL}$		70		90		120		150	ns
$t_{OE}^{(2)(3)}$	$\overline{OE}$ to Output Delay	$\overline{CE} = V_{IL}$		50		50		50		60	ns
$t_{DF}^{(4)(5)}$	$\overline{OE}$ or $\overline{CE}$ High to Output Float, whichever occurred first			40		40		40		50	ns
$t_{OH}$	Output Hold from Address, $\overline{CE}$ or $\overline{OE}$ , whichever occurred first		0		0		0		0		ns

## AC Waveforms for Read Operation<sup>(1)</sup>

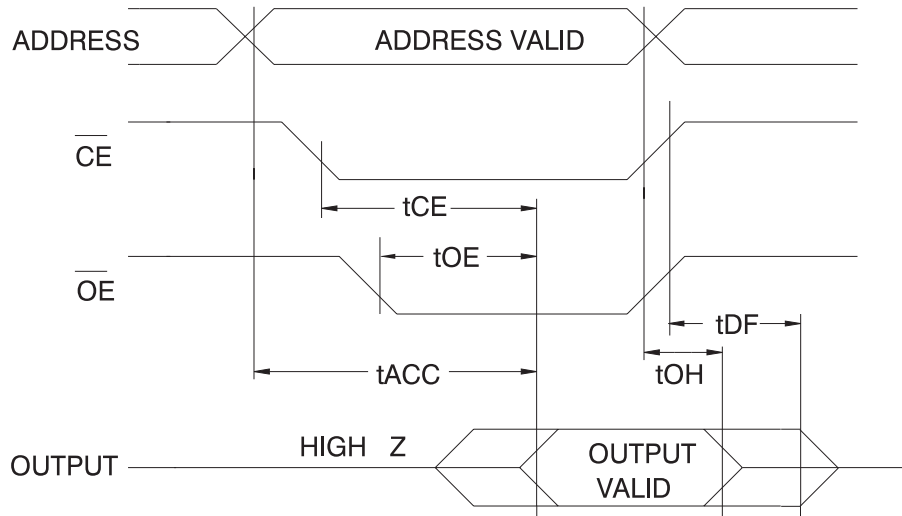

- Notes:
1. Timing measurement references are 0.8V and 2.0V. Input AC drive levels are 0.45V and 2.4V, unless otherwise specified.
  2.  $\overline{OE}$  may be delayed up to  $t_{CE} - t_{OE}$  after the falling edge of  $\overline{CE}$  without impact on  $t_{CE}$ .
  3.  $\overline{OE}$  may be delayed up to  $t_{ACC} - t_{OE}$  after the address is valid without impact on  $t_{ACC}$ .
  4. This parameter is only sampled and is not 100% tested.
  5. Output float is defined as the point when data is no longer driven.
  6. When reading a 27BV256, a 0.1  $\mu F$  capacitor is required across  $V_{CC}$  and ground to suppress spurious voltage transients.

### Input Test Waveform and Measurement Level

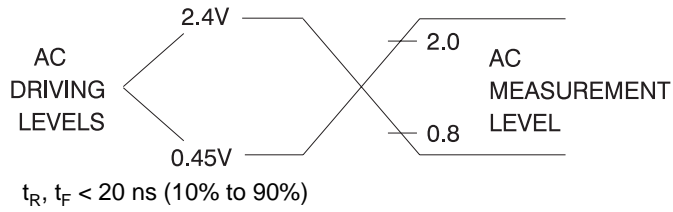

### Output Test Load

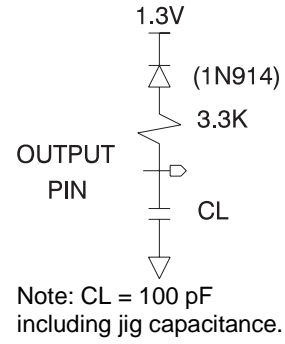

### Pin Capacitance

$f = 1 \text{ MHz}$ ,  $T = 25^\circ\text{C}^{(1)}$

Symbol	Typ	Max	Units	Conditions
$C_{IN}$	4	8	pF	$V_{IN} = 0V$
$C_{OUT}$	8	12	pF	$V_{OUT} = 0V$

Note: 1. Typical values for nominal supply voltage. This parameter is only sampled and is not 100% tested.

## Programming Waveforms<sup>(1)</sup>

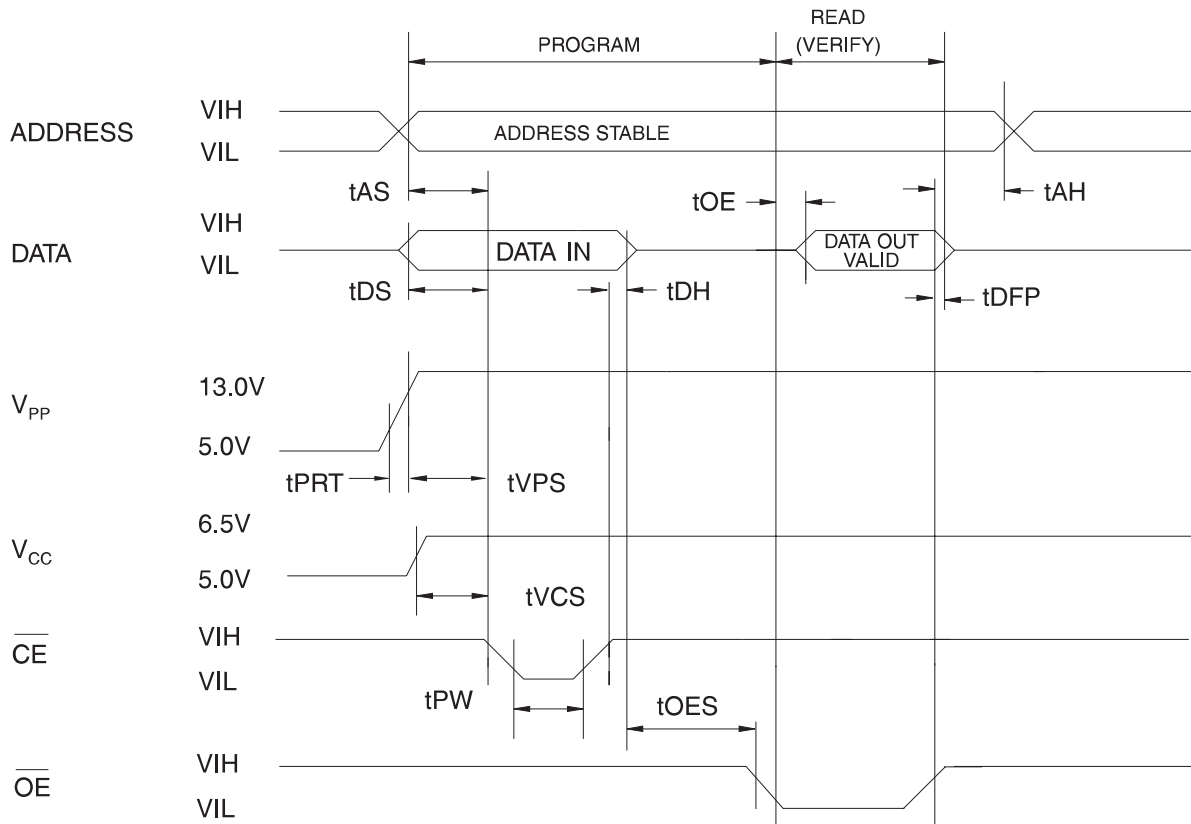

- Notes:
1. The Input Timing Reference is 0.8V for V<sub>IL</sub> and 2.0V for V<sub>IH</sub>.
  2. t<sub>OE</sub> and t<sub>DFP</sub> are characteristics of the device but must be accommodated by the programmer.
  3. When programming the AT27BV256 a 0.1 μF capacitor is required across V<sub>PP</sub> and ground to suppress spurious voltage transients.

## DC Programming Characteristics

TA = 25 ± 5°C, V<sub>CC</sub> = 6.5 ± 0.25V, V<sub>PP</sub> = 13.0 ± 0.25V

Symbol	Parameter	Test Conditions	Limits		Units
			Min	Max	
I <sub>LI</sub>	Input Load Current	V <sub>IN</sub> = V <sub>IL</sub> , V <sub>IH</sub>		±10	μA
V <sub>IL</sub>	Input Low Level		-0.6	0.8	V
V <sub>IH</sub>	Input High Level		2.0	V <sub>CC</sub> + 0.5	V
V <sub>OL</sub>	Output Low Voltage	I <sub>OL</sub> = 2.1 mA		0.4	V
V <sub>OH</sub>	Output High Voltage	I <sub>OH</sub> = -400 μA	2.4		V
I <sub>CC2</sub>	V <sub>CC</sub> Supply Current (Program and Verify)			25	mA
I <sub>PP2</sub>	V <sub>PP</sub> Current	CE = V <sub>IL</sub>		25	mA
V <sub>ID</sub>	A9 Product Identification Voltage		11.5	12.5	V



## AC Programming Characteristics

$T_A = 25 \pm 5^\circ\text{C}$ ,  $V_{CC} = 6.5 \pm 0.25\text{V}$ ,  $V_{PP} = 13.0 \pm 0.25\text{V}$

Symbol	Parameter	Test Conditions <sup>(1)</sup>	Limits		Units
			Min	Max	
$t_{AS}$	Address Setup Time	Input Rise and Fall Times: (10% to 90%) 20 ns	2		$\mu\text{s}$
$t_{OES}$	$\overline{OE}$ Setup Time		2		$\mu\text{s}$
$t_{DS}$	Data Setup Time		2		$\mu\text{s}$
$t_{AH}$	Address Hold Time	Input Pulse Levels: 0.45V to 2.4V	0		$\mu\text{s}$
$t_{DH}$	Data Hold Time		2		$\mu\text{s}$
$t_{DFP}$	$\overline{OE}$ High to Output Float Delay <sup>(2)</sup>		0	130	ns
$t_{VPS}$	$V_{PP}$ Setup Time	Input Timing Reference Level: 0.8V to 2.0V	2		$\mu\text{s}$
$t_{VCS}$	$V_{CC}$ Setup Time		2		$\mu\text{s}$
$t_{PW}$	$\overline{CE}$ Program Pulse Width <sup>(3)</sup>	Output Timing Reference Level: 0.8V to 2.0V	95	105	$\mu\text{s}$
$t_{OE}$	Data Valid from $\overline{OE}$ <sup>(2)</sup>			150	ns
$t_{PRT}$	$V_{PP}$ Pulse Rise Time During Programming		50		ns

- Notes:
- $V_{CC}$  must be applied simultaneously or before  $V_{PP}$  and removed simultaneously or after  $V_{PP}$ .
  - This parameter is only sampled and is not 100% tested. Output Float is defined as the point where data is no longer driven—see timing diagram.
  - Program Pulse width tolerance is  $100 \mu\text{sec} \pm 5\%$ .

## Atmel's 27BV256 Integrated Product Identification Code<sup>(1)</sup>

Codes	Pins									Hex Data
	A0	O7	O6	O5	O4	O3	O2	O1	O0	
Manufacturer	0	0	0	0	1	1	1	1	0	1E
Device Type	1	1	0	0	0	1	1	0	0	8C

- Note:
- The AT27BV256 has the same Product Identification Code as the AT27C256R and AT27LV256A. They are all programming compatible.

### Rapid Programming Algorithm

A 100  $\mu\text{s}$   $\overline{\text{CE}}$  pulse width is used to program. The address is set to the first location.  $V_{\text{CC}}$  is raised to 6.5V and  $V_{\text{PP}}$  is raised to 13.0V. Each address is first programmed with one 100  $\mu\text{s}$   $\overline{\text{CE}}$  pulse without verification. Then a verification/reprogramming loop is executed for each address. In the event a byte fails to pass verification, up to 10 successive 100  $\mu\text{s}$  pulses are applied with a verification after each

pulse. If the byte fails to verify after 10 pulses have been applied, the part is considered failed. After the byte verifies properly, the next address is selected until all have been checked.  $V_{\text{PP}}$  is then lowered to 5.0V and  $V_{\text{CC}}$  to 5.0V. All bytes are read again and compared with the original data to determine if the device passes or fails.

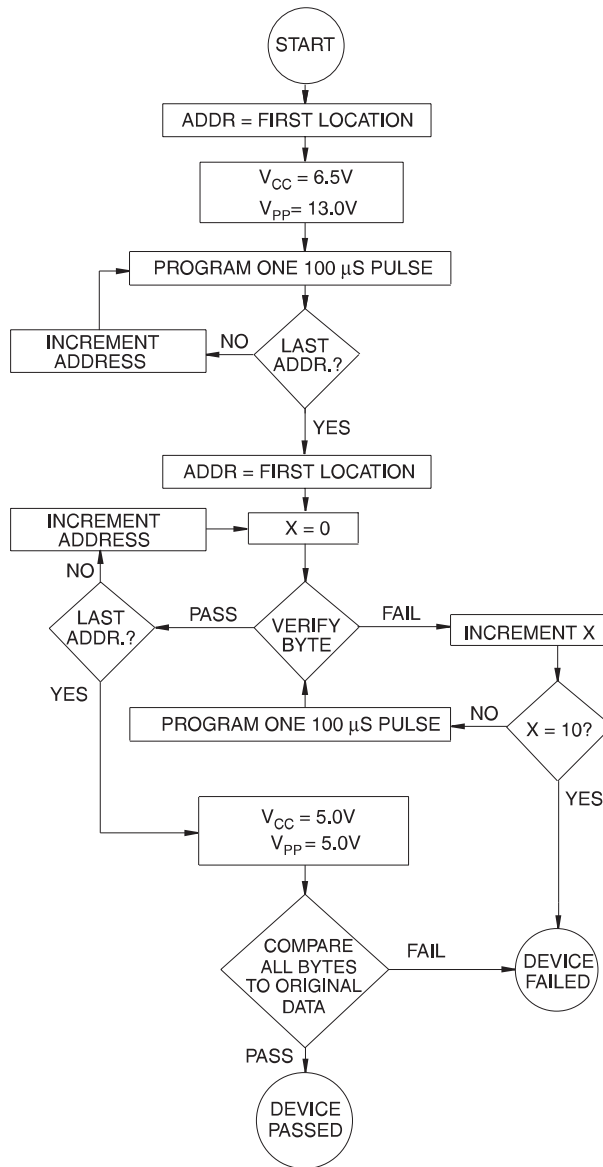



## Ordering Information

t <sub>ACC</sub> (ns)	I <sub>CC</sub> (mA)		Ordering Code	Package	Operation Range
	Active	Standby			
70	8	0.02	AT27BV256-70JC AT27BV256-70RC AT27BV256-70TC	32J 28R 28T	Commercial (0°C to 70°C)
	8	0.02	AT27BV256-70JI AT27BV256-70RI AT27BV256-70TI	32J 28R 28T	Industrial (-40°C to 85°C)
90	8	0.02	AT27BV256-90JC AT27BV256-90RC AT27BV256-90TC	32J 28R 28T	Commercial (0°C to 70°C)
	8	0.02	AT27BV256-90JI AT27BV256-90RI AT27BV256-90TI	32J 28R 28T	Industrial (-40°C to 85°C)
120	8	0.02	AT27BV256-12JC AT27BV256-12RC AT27BV256-12TC	32J 28R 28T	Commercial (0°C to 70°C)
	8	0.02	AT27BV256-12JI AT27BV256-12RI AT27BV256-12TI	32J 28R 28T	Industrial (-40°C to 85°C)
150	8	0.02	AT27BV256-15JC AT27BV256-15RC AT27BV256-15TC	32J 28R 28T	Commercial (0°C to 70°C)
	8	0.02	AT27BV256-15JI AT27BV256-15RI AT27BV256-15TI	32J 28R 28T	Industrial (-40°C to 85°C)

Package Type	
<b>32J</b>	32-Lead, Plastic J-Leaded Chip Carrier (PLCC)
<b>28R</b>	28-Lead, 0.330" Wide, Plastic Gull Wing Small Package (SOIC)
<b>28T</b>	28-Lead, Plastic Thin Small Outline Package

Packaging Information

**32J, 32-Lead, Plastic J-Leaded Chip Carrier (PLCC)**  
 Dimensions in Inches and (Millimeters)  
 JEDEC STANDARD MS-016 AE

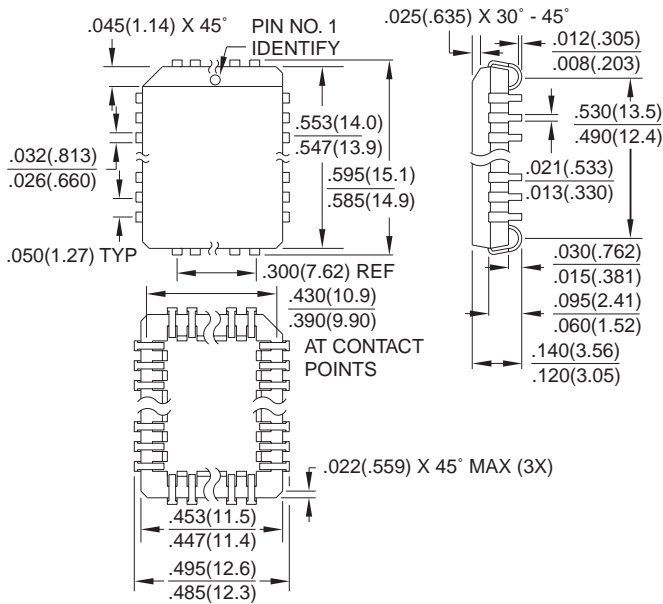

**28R, 28-Lead, 0.330" Wide, Plastic Gull Wing Small Outline (SOIC)**  
 Dimensions in Inches and (Millimeters)

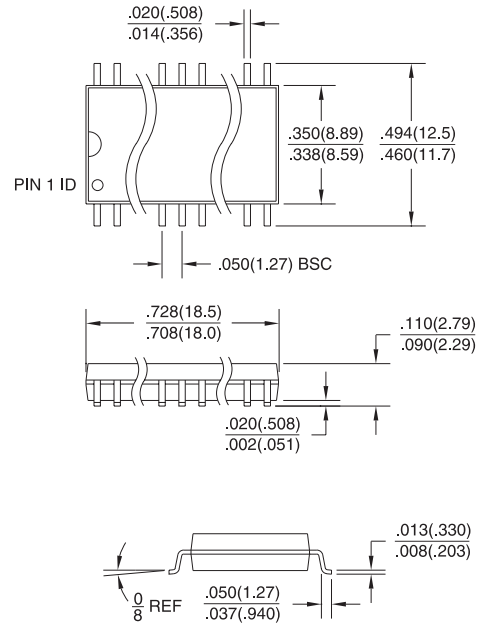

**28T, 28-Lead, Plastic Thin Small Outline Package (TSOP)**  
 Dimensions in Millimeters and (Inches)\*

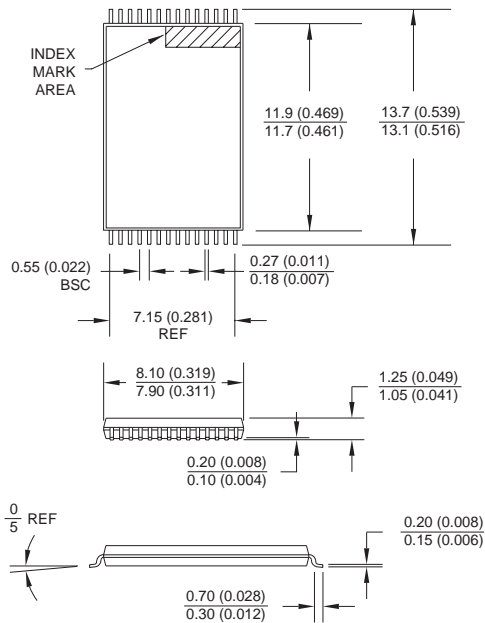

\*Controlling dimension: millimeters



## Atmel Headquarters

**Corporate Headquarters**  
2325 Orchard Parkway  
San Jose, CA 95131  
TEL (408) 441-0311  
FAX (408) 487-2600

### Europe

Atmel U.K., Ltd.  
Coliseum Business Centre  
Riverside Way  
Camberley, Surrey GU15 3YL  
England  
TEL (44) 1276-686677  
FAX (44) 1276-686697

### Asia

Atmel Asia, Ltd.  
Room 1219  
Chinachem Golden Plaza  
77 Mody Road  
Tsimshatsui East  
Kowloon, Hong Kong  
TEL (852) 27219778  
FAX (852) 27221369

### Japan

Atmel Japan K.K.  
Tonetsu Shinkawa Bldg., 9F  
1-24-8 Shinkawa  
Chuo-ku, Tokyo 104-0033  
Japan  
TEL (81) 3-3523-3551  
FAX (81) 3-3523-7581

## Atmel Operations

**Atmel Colorado Springs**  
1150 E. Cheyenne Mtn. Blvd.  
Colorado Springs, CO 80906  
TEL (719) 576-3300  
FAX (719) 540-1759

### Atmel Rousset

Zone Industrielle  
13106 Rousset Cedex, France  
TEL (33) 4 42 53 60 00  
FAX (33) 4 42 53 60 01

---

### ***Fax-on-Demand***

North America:  
1-(800) 292-8635  
International:  
1-(408) 441-0732

### ***e-mail***

[literature@atmel.com](mailto:literature@atmel.com)

### ***Web Site***

<http://www.atmel.com>

### ***BBS***

1-(408) 436-4309

### © Atmel Corporation 1998.

Atmel Corporation makes no warranty for the use of its products, other than those expressly contained in the Company's standard warranty which is detailed in Atmel's Terms and Conditions located on the Company's website. The Company assumes no responsibility for any errors which may appear in this document, reserves the right to change devices or specifications detailed herein at any time without notice, and does not make any commitment to update the information contained herein. No licenses to patents or other intellectual property of Atmel are granted by the Company in connection with the sale of Atmel products, expressly or by implication. Atmel's products are not authorized for use as critical components in life support devices or systems.

Marks bearing ® and/or ™ are registered trademarks and trademarks of Atmel Corporation.

Terms and product names in this document may be trademarks of others.



Printed on recycled paper.

0601B-05/98/xM

## Looking for pricing, stock, or lifecycle information?

Click below to explore more details on WIN SOURCE:

- ⊖ [View AT27BV256-12JC on WIN SOURCE](#)
- ⊖ [Microchip Technology](#) Information

## Optimize Your Supply Chain with WIN SOURCE Solutions

- ✓ Global Sourcing Solution
- ✓ Obsolete Management
- ✓ Cost Control Management
- ✓ Shortage Management
- ✓ Alternative Solution
- ✓ Excess Inventory Management