



**THE DATASHEET OF  
ASP-184330-01**



NOTES:

1. VITA 57.4 CONNECTOR.
2.  $\text{\textcircled{C}}$  REPRESENTS A CRITICAL DIMENSION.
3. MINIMUM PUSHOUT FORCE: 0.50 LBS.
4. NOTE DELETED.
5. NOTE DELETED.
6. NOTE DELETED.
7. ATTACH LABEL "SEAX-0001" TO EACH TAPE & REEL PACKAGE.
8. NOTE DELETED.
9.  $\text{\textcircled{C}}$  MAXIMUM ROW TO ROW VARIATION .003[0.08], MEASURED FIRST & LAST POSITIONS ONLY, ALL ROWS.
10. PARTS TO BE PACKAGED IN TAPE AND REEL.
11. NOTE DELETED.

**Pb** THIS PRODUCT MANUFACTURED WITH LEAD-FREE PROCESSING

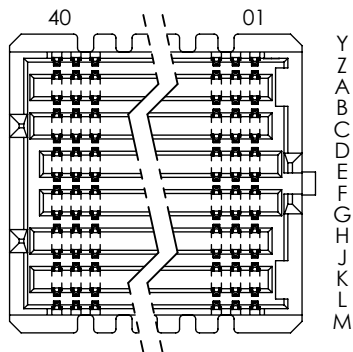
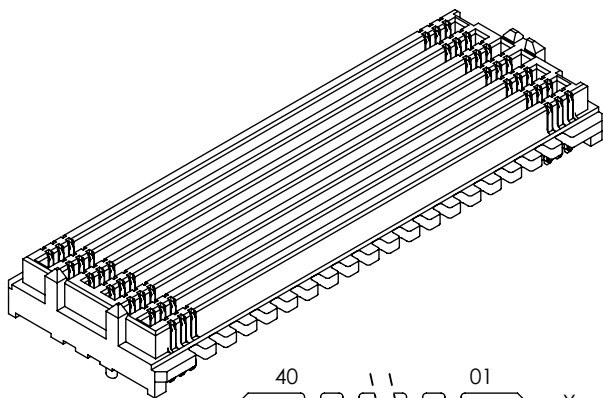

VITA 57.4 DETAIL

BY SIGNING THIS DOCUMENT YOU ARE ACCEPTING THE CONDITIONS SET WITHIN. YOUR REQUIREMENTS MUST BE LISTED WITHIN THIS DRAWING. WHERE NO DIRECTION FROM THE CUSTOMER IS IDENTIFIED SAMTEC'S PROCESS REQUIREMENTS WILL BE USED.

DATE: \_\_\_\_\_  
 COMPANY: \_\_\_\_\_  
 CUSTOMER SIGNATURE: \_\_\_\_\_  
 PRINTED NAME: \_\_\_\_\_  
 PHONE NO: \_\_\_\_\_  
 EXCEPTIONS: \_\_\_\_\_

ANY REV MADE TO THIS PRINT MUST HAVE AN UPDATED MKT PRINT

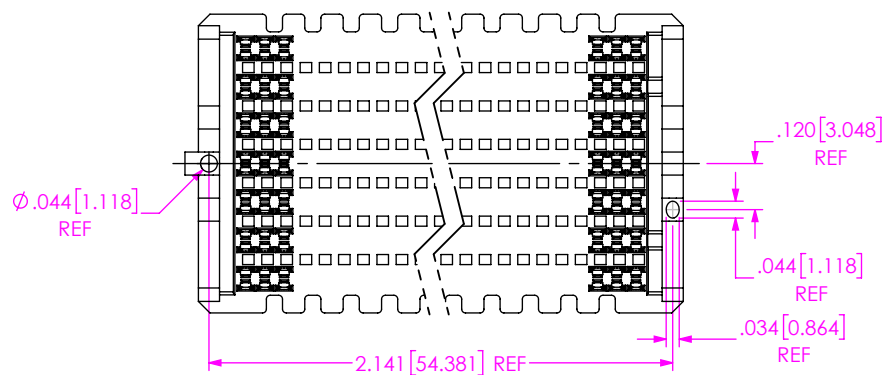
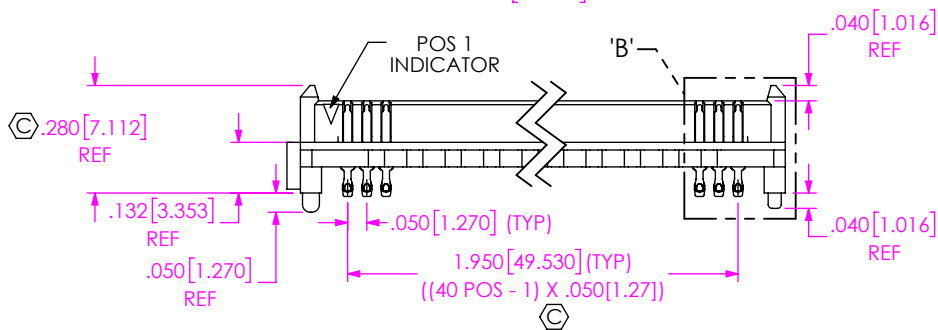
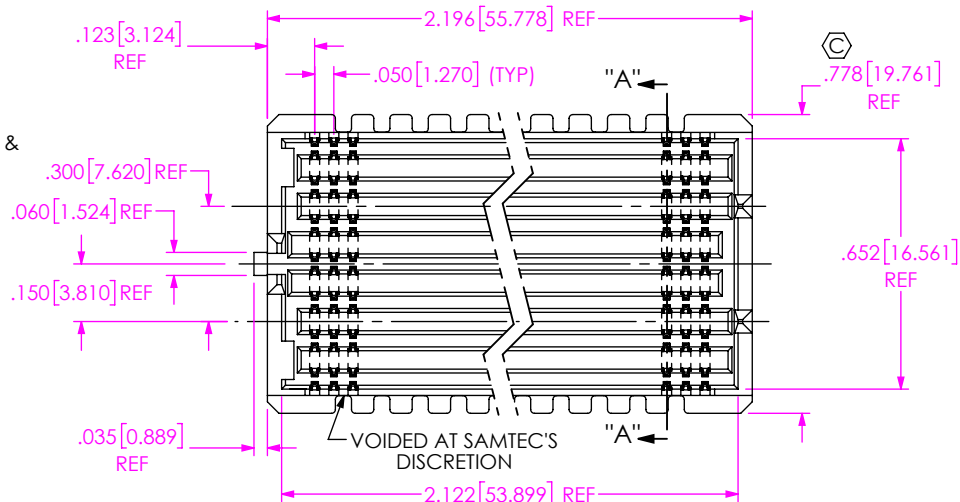

ITEM NO.	PART NUMBER	QUANTITY	MATERIAL
1	SEAM-40-03.5-14-A	1.0000	LCP, UL 94 VO, COLOR: BLACK
2	NEW-SUB-T-1M36-03.5-S-2	560.00	COPPER ALLOY / LEAD FREE SOLDER
3	K-DOT-.404-.500-.005	1.0000	POLYIMIDE FILM
4	CT-SEAM182MS	.00667	CONDUCTIVE POLYMER

UNLESS OTHERWISE SPECIFIED, DIMENSIONS ARE IN INCHES. TOLERANCES ARE:  
 DECIMALS ANGLES  
 .XX: ±.01 [0.3] 2°  
 .XXX: ±.005 [0.13]  
 .XXXX: ±.0020 [0.051]

PROPRIETARY NOTE  
 THIS DOCUMENT CONTAINS CONFIDENTIAL AND PROPRIETARY INFORMATION AND ALL DESIGN, MANUFACTURING, REPRODUCTION, USE, PATENT RIGHTS AND SALES RIGHTS ARE EXPRESSLY RESERVED BY SAMTEC, INC. THIS DOCUMENT SHALL NOT BE DISCLOSED, IN WHOLE OR PART, TO ANY UNAUTHORIZED PERSON OR ENTITY NOR REPRODUCED, TRANSFERRED OR INCORPORATED IN ANY OTHER PROJECT IN ANY MANNER WITHOUT THE EXPRESS WRITTEN CONSENT OF SAMTEC, INC.

DO NOT SCALE DRAWING SHEET SCALE: 2:1

PLATING:  
 CONTACT AREA: .00030 GOLD OVER .000050 NICKEL  
 REMAINDER: .000200 REF TIN OVER .000050 NICKEL

DESCRIPTION:  
 14 ROW .050 PITCH TERMINAL ARRAY ASM  
 DWG. NO. ASP-184330-01  
 BY: A ZAMORA 11/18/2014 SHEET 1 OF 4

520 PARK EAST BLVD, NEW ALBANY, IN 47150  
 PHONE: 812-944-6733 FAX: 812-948-5047  
 e-Mail: info@SAMTEC.com code 55322

F:\DWG\MISC\MKTG\ASP-184330-01-MKT.SLDDRW

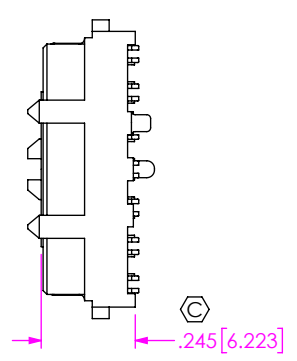
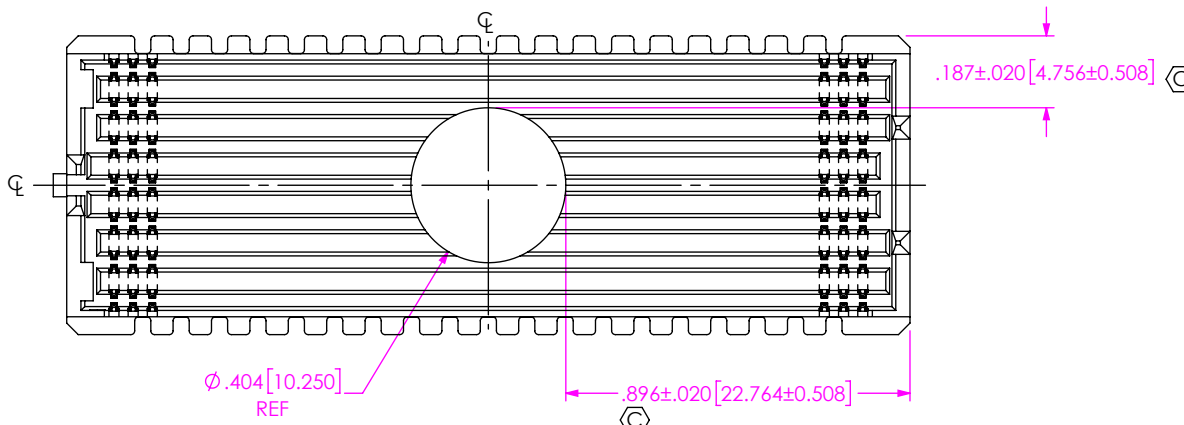
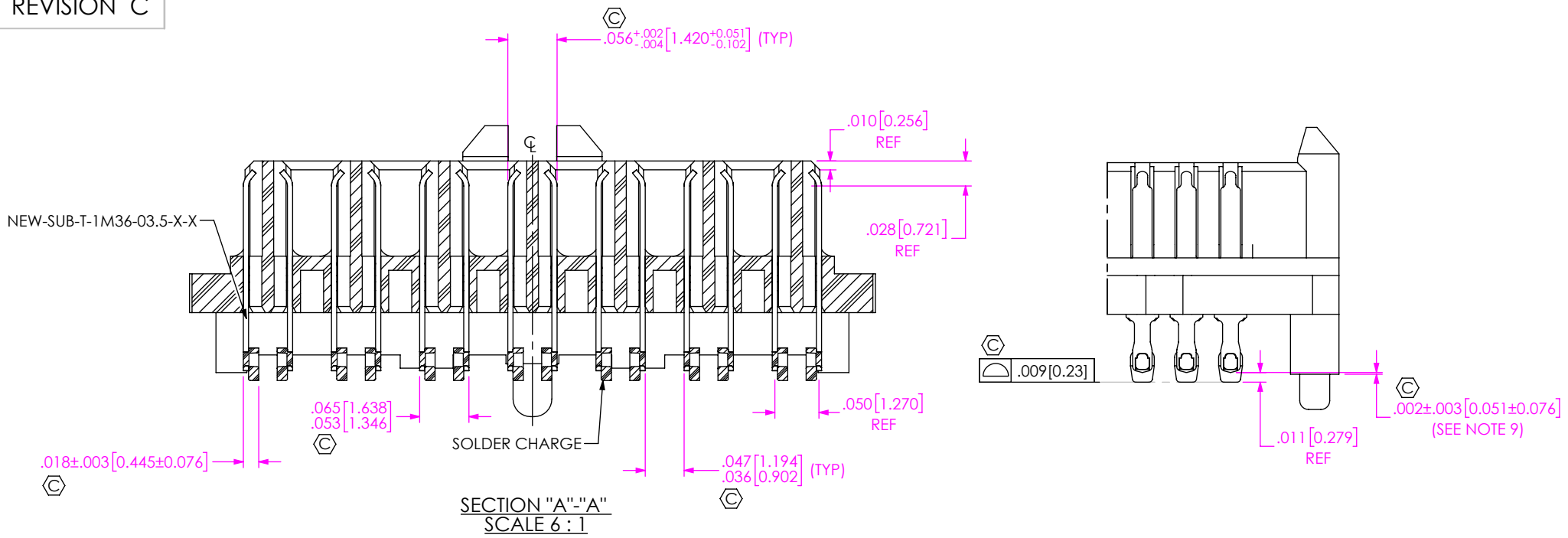

PAD VIEW

<p><b>PROPRIETARY NOTE</b></p> <p>THIS DOCUMENT CONTAINS CONFIDENTIAL AND PROPRIETARY INFORMATION AND ALL DESIGN, MANUFACTURING, REPRODUCTION, USE, PATENT RIGHTS AND SALES RIGHTS ARE EXPRESSLY RESERVED BY SAMTEC, INC. THIS DOCUMENT SHALL NOT BE DISCLOSED, IN WHOLE OR PART, TO ANY UNAUTHORIZED PERSON OR ENTITY NOR REPRODUCED, TRANSFERRED OR INCORPORATED IN ANY OTHER PROJECT IN ANY MANNER WITHOUT THE EXPRESS WRITTEN CONSENT OF SAMTEC, INC.</p> <p>DO NOT SCALE DRAWING</p> <p>SHEET SCALE: 2:1</p>		
	<p>520 PARK EAST BLVD. NEW ALBANY, IN 47150                  PHONE: 812-944-6733 FAX: 812-948-5047                  e-Mail info@SAMTEC.com code 55322</p>	
	<p>DESCRIPTION:                  14 ROW .050 PITCH TERMINAL ARRAY ASM</p>	
<p>DWG. NO. <b>ASP-184330-01</b></p>		<p>BY: A ZAMORA 11/18/2014 SHEET 2 OF 4</p>



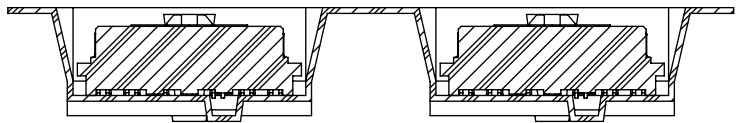
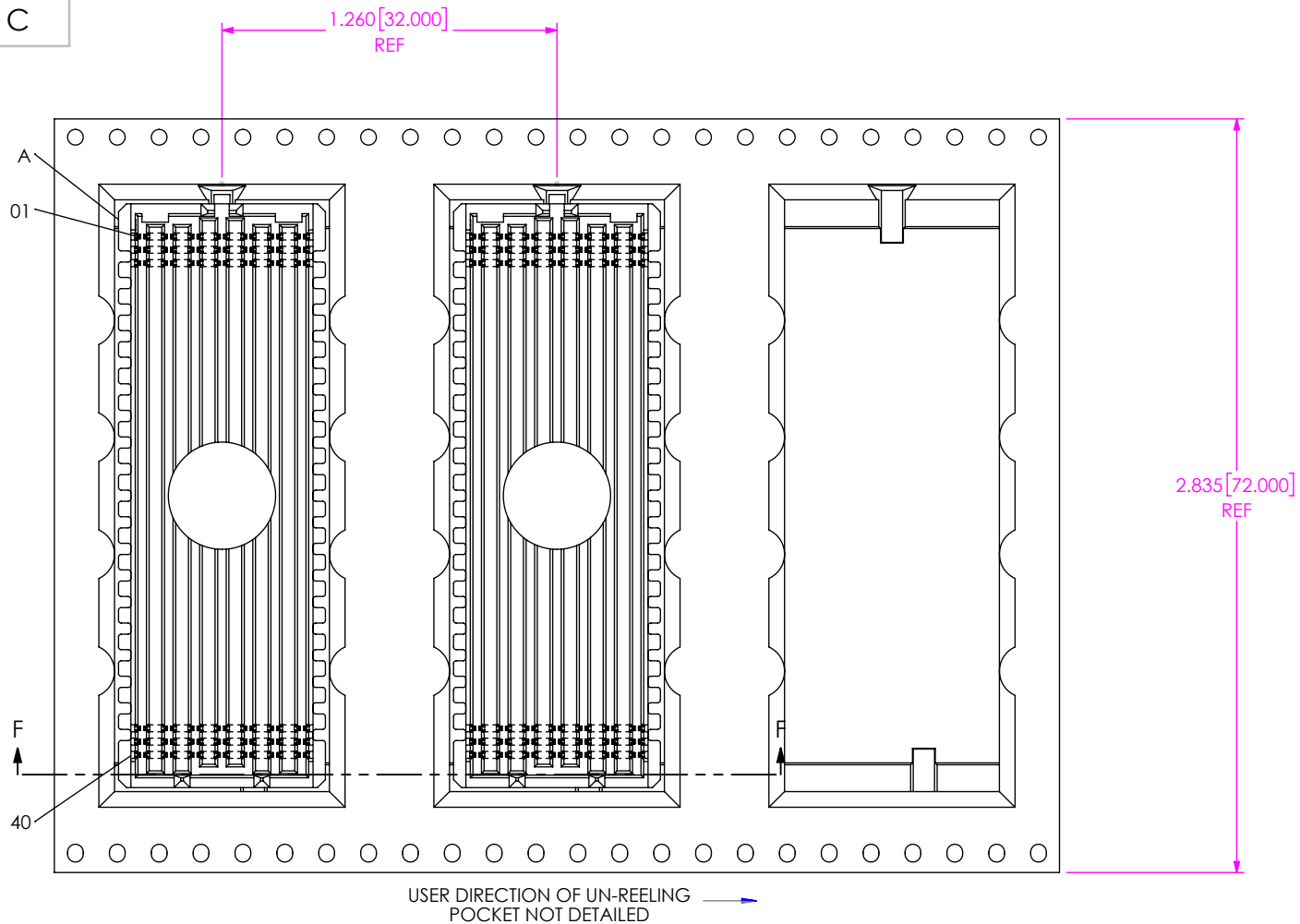

SECTION F-F  
SCALE 1.5 : 1

CRITICAL DIMENSION INSPECTION INSTRUCTION TABLE	
ASSEMBLY OPERATION	IN-PROCESS INSPECTION
FILL NEW-SUB-T-1M36-03.5-S-2	C1, C2, C3, C4, C6, C7, C8, C9, C10
ADD K DOT	C11, C12, C13
FINISHED GOOD INSPECTION	C14

**PROPRIETARY NOTE**  
 \* THIS DOCUMENT CONTAINS CONFIDENTIAL AND PROPRIETARY INFORMATION AND ALL DESIGN, MANUFACTURING, REPRODUCTION, USE, PATENT RIGHTS AND SALES RIGHTS ARE EXPRESSLY RESERVED BY SAMTEC, INC. THIS DOCUMENT SHALL NOT BE DISCLOSED, IN WHOLE OR PART, TO ANY UNAUTHORIZED PERSON OR ENTITY NOR REPRODUCED, TRANSFERRED OR INCORPORATED IN ANY OTHER PROJECT IN ANY MANNER WITHOUT THE EXPRESS WRITTEN CONSENT OF SAMTEC, INC. \*

**samtec**  
 520 PARK EAST BLVD., NEW ALBANY, IN 47150  
 PHONE: 812-944-6733 FAX: 812-948-5047  
 e-Mail info@SAMTEC.com code 55322

SHEET SCALE: 3:1  
 F:\DWG\MISC\MKTG\ASP-184330-01-MKT.SLDDRW

DESCRIPTION:  
 14 ROW .050 PITCH TERMINAL ARRAY ASM  
 DWG. NO.  
**ASP-184330-01**  
 BY: A ZAMORA 11/18/2014 SHEET 4 OF 4

## Looking for pricing, stock, or lifecycle information?

Click below to explore more details on WIN SOURCE:

 [View ASP-184330-01](#) on WIN SOURCE

 [Samtec Inc.](#) Information

## Optimize Your Supply Chain with WIN SOURCE Solutions

-  Global Sourcing Solution
-  Obsolete Management
-  Cost Control Management
-  Shortage Management
-  Alternative Solution
-  Excess Inventory Management