



**THE DATASHEET OF
AS7C1026C-15JIN**





5 V 64K X 16 CMOS SRAM

Features

- Industrial (-40° to 85°C) temperature
- Organization: 65,536 words × 16 bits
- Center power and ground pins for low noise
- High speed
 - 15 ns address access time
 - 6 ns output enable access time
- Low power consumption via chip deselect
- Easy memory expansion with \overline{CE} , \overline{OE} inputs
- TTL-compatible, three-state I/O
- Upper and Lower byte pin
- JEDEC standard packaging
 - 44-pin 400 mil SOJ
 - 44-pin TSOP 2-400
- ESD protection ≥ 2000 volts

Pin arrangement

44-Pin SOJ (400 mil), TSOP 2

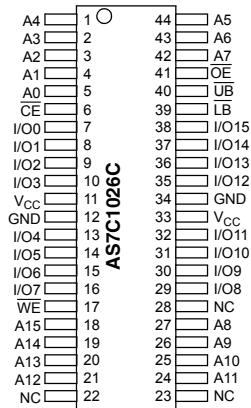

Logic block diagram

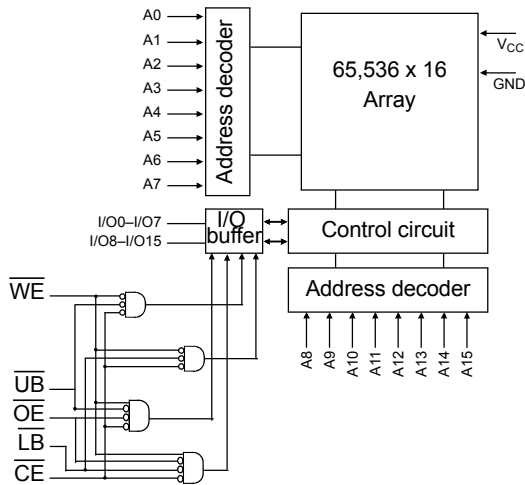



Functional description

The AS7C1026C is a 5V high-performance CMOS 1,048,576-bit Static Random Access Memory (SRAM) device organized as 65,536 words × 16 bits. It is designed for memory applications where fast data access, low power, and simple interfacing are desired.

Equal address access and cycle times (t_{AA} , t_{RC} , t_{WC}) of 15 ns with output enable access times (t_{OE}) of 6 ns are ideal for high-performance applications.

When \overline{CE} is high, the device enters standby mode. If inputs are still toggling, the device will consume I_{SB} power. If the bus is static, then full standby power is reached (I_{SB1}).

A write cycle is accomplished by asserting write enable (\overline{WE}) and chip enable (\overline{CE}). Data on the input pins I/O0 through I/O15 is written on the rising edge of \overline{WE} (write cycle 1) or \overline{CE} (write cycle 2). To avoid bus contention, external devices should drive I/O pins only after outputs have been disabled with output enable (\overline{OE}) or write enable (\overline{WE}).

A read cycle is accomplished by asserting output enable (\overline{OE}) and chip enable (\overline{CE}) with write enable (\overline{WE}) high. The chip drives I/O pins with the data word referenced by the input address. When either chip enable or output enable is inactive or write enable is active, output drivers stay in high-impedance mode.

The device provides multiple center power and ground pins, and separate byte enable controls, allowing individual bytes to be written and read. \overline{LB} controls the lower bits, I/O0 through I/O7, and \overline{UB} controls the higher bits, I/O8 through I/O15.

All chip inputs and outputs are TTL-compatible, and operation is from a single 5 V supply. The AS7C1026C is packaged in common industry standard packages.

Absolute maximum ratings

Parameter	Symbol	Min	Max	Unit
Voltage on V_{CC} relative to GND	V_{t1}	-0.50	+7.0	V
Voltage on any pin relative to GND	V_{t2}	-0.50	$V_{CC} + 0.50$	V
Power dissipation	P_D	-	1.25	W
Storage temperature (plastic)	T_{stg}	-55	+125	°C
Ambient temperature with VCC applied	T_{bias}	-55	+125	°C
DC current into outputs (low)	I_{OUT}	-	50	mA

Note:

Stresses greater than those listed under *Absolute Maximum Ratings* may cause permanent damage to the device. This is a stress rating only and functional operation of the device at these or any other conditions outside those indicated in the operational sections of this specification is not implied. Exposure to absolute maximum rating conditions for extended periods may affect reliability.

Truth table

\overline{CE}	\overline{WE}	\overline{OE}	\overline{LB}	\overline{UB}	I/O0–I/O7	I/O8–I/O15	Mode
H	X	X	X	X	High Z	High Z	Standby (I_{SB}), I_{SB1})
L	H	L	L	H	D_{OUT}	High Z	Read I/O0–I/O7 (I_{CC})
L	H	L	H	L	High Z	D_{OUT}	Read I/O8–I/O15 (I_{CC})
L	H	L	L	L	D_{OUT}	D_{OUT}	Read I/O0–I/O15 (I_{CC})
L	L	X	L	L	D_{IN}	D_{IN}	Write I/O0–I/O15 (I_{CC})
L	L	X	L	H	D_{IN}	High Z	Write I/O0–I/O7 (I_{CC})
L	L	X	H	L	High Z	D_{IN}	Write I/O8–I/O15 (I_{CC})
L	H	H	X	X	High Z	High Z	Output disable (I_{CC})
L	X	X	H	H	High Z	High Z	

Key: H = high, L = low, X = don't care.



Recommended operating conditions

Parameter	Symbol	Min	Nominal	Max	Unit
Supply voltage	V_{CC}	4.5	5.0	5.5	V
Input voltage	V_{IH}	2.2	–	$V_{CC} + 0.5$	V
	V_{IL}	–0.5	–	0.8	V
Ambient operating temperature (Industrial)	T_A	–40	–	85	°C

Notes:

V_{IL} min = –1.5V for pulse width less than 5ns, once per cycle.

V_{IH} max = $V_{CC} + 2.0V$ for pulse width less than 5ns, once per cycle.

DC operating characteristics (over the operating range)¹

Parameter	Sym	Test conditions	AS7C1026C-15		Unit
			Min	Max	
Input leakage current	$ I_{LI} $	$V_{CC} = \text{Max},$ $V_{IN} = \text{GND to } V_{CC}$	–	5	μA
Output leakage current	$ I_{LO} $	$V_{CC} = \text{Max}, \overline{CE} = V_{IH},$ $V_{OUT} = \text{GND to } V_{CC}$	–	5	μA
Operating power supply current	I_{CC}	$V_{CC} = \text{Max},$ $\overline{CE} ? V_{IL}, I_{OUT} = 0\text{mA},$ $f = f_{\text{Max}}$	–	210	mA
Standby power supply current	I_{SB}	$V_{CC} = \text{Max},$ $\overline{CE} ? V_{IH}, f = f_{\text{Max}}$	–	60	mA
	I_{SB1}	$V_{CC} = \text{Max}, \overline{CE} ? V_{CC} - 0.2 \text{ V},$ $V_{IN} ? 0.2 \text{ V or}$ $V_{IN} ? V_{CC} - 0.2 \text{ V}, f = 0$	–	10	mA
Output voltage	V_{OL}	$I_{OL} = 8 \text{ mA}, V_{CC} = \text{Min}$	–	0.4	V
	V_{OH}	$I_{OH} = -4 \text{ mA}, V_{CC} = \text{Min}$	2.4	–	V

Capacitance ($f = 1\text{MHz}, T_a = 25^\circ\text{C}, V_{CC} = \text{NOMINAL}$)²

Parameter	Symbol	Signals	Test conditions	Max	Unit
Input capacitance	C_{IN}	A, \overline{CE} , \overline{WE} , \overline{OE} , \overline{LB} , \overline{UB}	$V_{IN} = 0 \text{ V}$	6	pF
I/O capacitance	$C_{I/O}$	I/O	$V_{OUT} = 0 \text{ V}$	7	pF

Note:

This parameter is guaranteed by device characterization, but is not production tested.



Write cycle (over the operating range) ¹¹

Parameter	Symbol	AS7C1026C-15		Unit	Notes
		Min	Max		
Write cycle time	t_{WC}	15	–	ns	
Chip enable (\overline{CE}) to write end	t_{CW}	9	–	ns	
Address setup to write end	t_{AW}	9	–	ns	
Address setup time	t_{AS}	0	–	ns	
Write pulse width	t_{WP}	9	–	ns	
Write recovery time	t_{WR}	0	–	ns	
Address hold from end of write	t_{AH}	0	–	ns	
Data valid to write end	t_{DW}	7	–	ns	
Data hold time	t_{DH}	0	–	ns	5
Write enable to output in high Z	t_{WZ}	–	6	ns	4, 5
Output active from write end	t_{OW}	1	–	ns	4, 5
Byte select low to end of write	t_{BW}	9	–	ns	

Write waveform 1 (\overline{WE} controlled) ¹¹

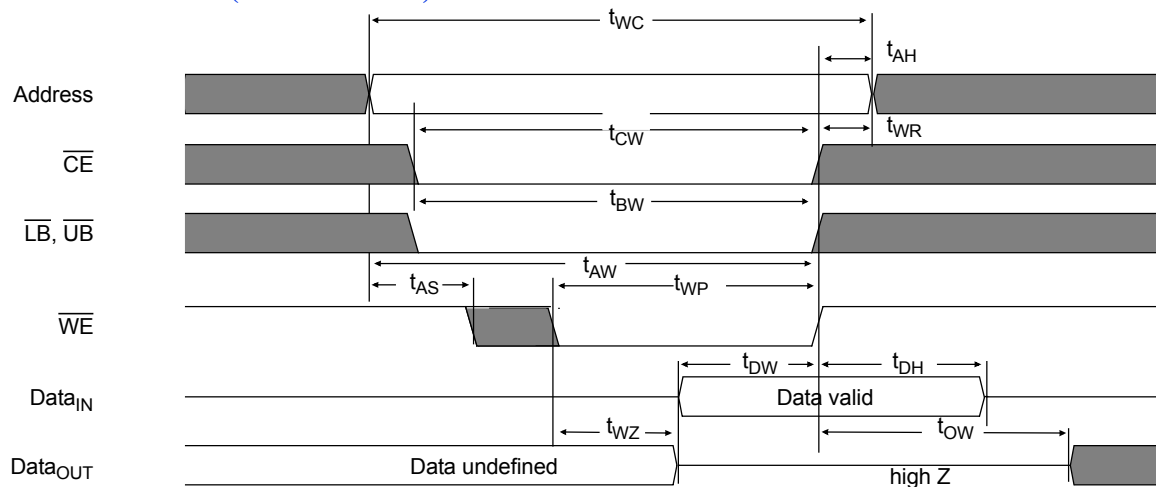



Write waveform 2 ($\overline{\text{CE}}$ controlled)¹¹

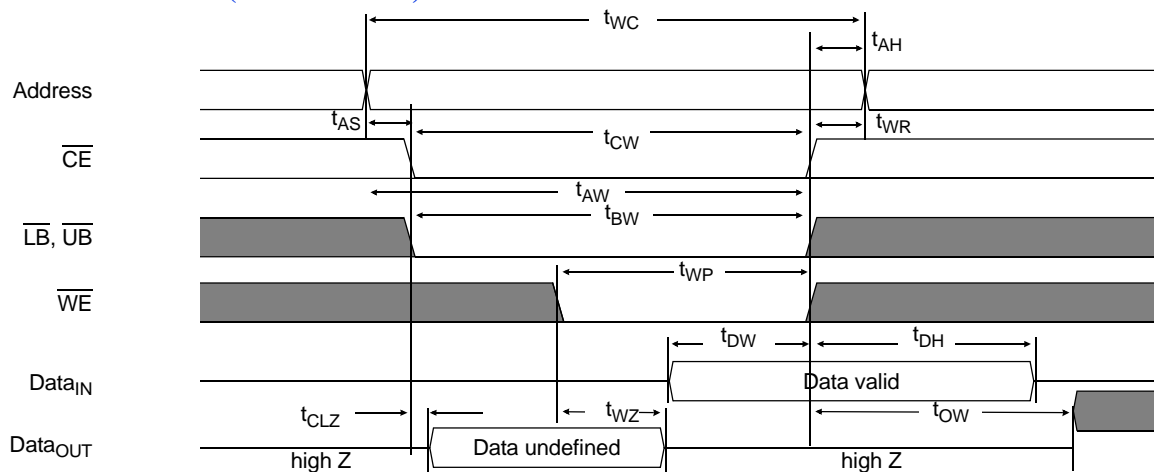

AC test conditions

- Output load: see Figure B.
- Input pulse level: GND to 3.0 V. See Figure A.
- Input rise and fall times: 3 ns. See Figure A.
- Input and output timing reference levels: 1.5

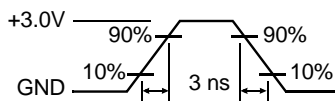

Figure A: Input pulse

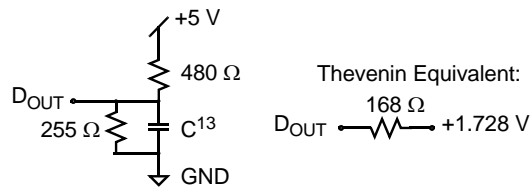

Figure B: 5 V Output load

Notes:

- 1 During V_{CC} power-up, a pull-up resistor to V_{CC} on $\overline{\text{CE}}$ is required to meet I_{SB} specification.
- 2 This parameter is sampled, but not 100% tested.
- 3 For test conditions, see *AC Test Conditions*, Figures A and B.
- 4 These parameters are specified with $C_L = 5$ pF, as in Figures B. Transition is measured ± 200 mV from steady-state voltage.
- 5 This parameter is guaranteed, but not tested.
- 6 $\overline{\text{WE}}$ is high for read cycle.
- 7 $\overline{\text{CE}}$ and $\overline{\text{OE}}$ are low for read cycle.
- 8 Address is valid prior to or coincident with $\overline{\text{CE}}$ transition low.
- 9 All read cycle timings are referenced from the last valid address to the first transitioning address.
- 10 N/A.
- 11 All write cycle timings are referenced from the last valid address to the first transitioning address.
- 12 Not applicable.
- 13 $C = 30$ pF, except all high Z and low Z parameters where $C = 5$ pF.



Package dimensions

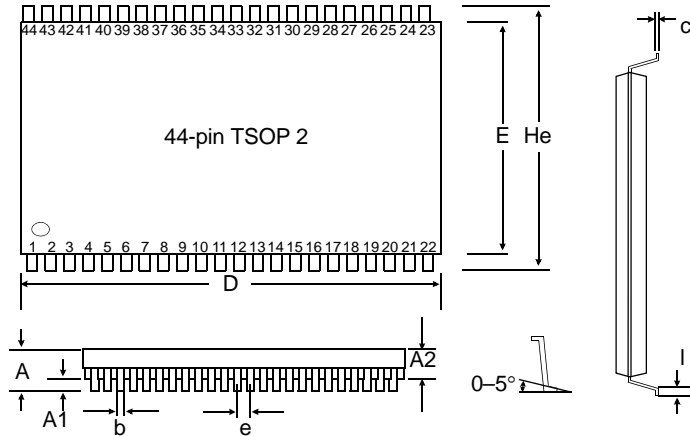

	44-pin TSOP 2	
	Min (mm)	Max (mm)
A		1.2
A1	0.05	0.15
A2	0.95	1.05
b	0.30	0.45
c	0.120	0.21
D	18.31	18.52
E	10.06	10.26
He	11.68	11.94
e	0.80 (typical)	
l	0.40	0.60

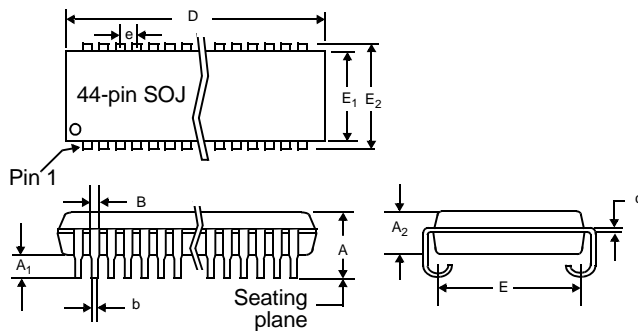

	44-pin SOJ 400 mil	
	Min (in)	Max (in)
A	0.128	0.148
A ₁	0.025	—
A ₂	0.105	0.115
B	0.026	0.032
b	0.015	0.020
c	0.007	0.013
D	1.120	1.130
E	0.370 NOM	
E ₁	0.395	0.405
E ₂	0.435	0.445
e	0.050 NOM	



Ordering codes

Package	Volt/Temp	15 ns
Plastic SOJ, 400 mil	5V Industrial	AS7C1026C-15JIN
TSOP 2, 10.2 x 18.4 mm	5V Industrial	AS7C1026C-15TIN

Part numbering system

AS7C	1026C	-XX	X	X	X
SRAM prefix	Device number	Access time	Package: J = SOJ 400 mil T = TSOP 2, 10.2 x 18.4 mm	Temperature range: I = industrial: -40° C to 85° C	N = LEAD FREE PART

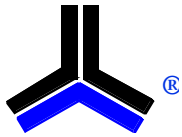

Alliance Memory, Inc.
1116 South Amphlett
San Mateo, CA 94402
Tel: 650-525-3737
Fax: 650-525-0449
www.alliancememory.com

Copyright © Alliance Memory
All Rights Reserved
Part Number: AS7C1026C
Document Version: v 1.0

© Copyright 2003 Alliance Memory, Inc. All rights reserved. Our three-point logo, our name and Intelliwatt are trademarks or registered trademarks of Alliance. All other brand and product names may be the trademarks of their respective companies. Alliance reserves the right to make changes to this document and its products at any time without notice. Alliance assumes no responsibility for any errors that may appear in this document. The data contained herein represents Alliance's best data and/or estimates at the time of issuance. Alliance reserves the right to change or correct this data at any time, without notice. If the product described herein is under development, significant changes to these specifications are possible. The information in this product data sheet is intended to be general descriptive information for potential customers and users, and is not intended to operate as, or provide, any guarantee or warranty to any user or customer. Alliance does not assume any responsibility or liability arising out of the application or use of any product described herein, and disclaims any express or implied warranties related to the sale and/or use of Alliance products including liability or warranties related to fitness for a particular purpose, merchantability, or infringement of any intellectual property rights, except as express agreed to in Alliance's Terms and Conditions of Sale (which are available from Alliance). All sales of Alliance products are made exclusively according to Alliance's Terms and Conditions of Sale. The purchase of products from Alliance does not convey a license under any patent rights, copyrights; mask works rights, trademarks, or any other intellectual property rights of Alliance or third parties. Alliance does not authorize its products for use as critical components in life-supporting systems where a malfunction or failure may reasonably be expected to result in significant injury to the user, and the inclusion of Alliance products in such life-supporting systems implies that the manufacturer assumes all risk of such use and agrees to indemnify Alliance against all claims arising from such use.

Looking for pricing, stock, or lifecycle information?

Click below to explore more details on WIN SOURCE:

 [View AS7C1026C-15JIN on WIN SOURCE](#)

 [Alliance Memory, Inc. Information](#)

Optimize Your Supply Chain with WIN SOURCE Solutions

-  Global Sourcing Solution
-  Obsolete Management
-  Cost Control Management
-  Shortage Management
-  Alternative Solution
-  Excess Inventory Management