



# THE DATASHEET OF AS6C4008A-55STIN





Rev. 1.12

# AS6C4008A

## 512K X 8 BIT LOW POWER CMOS SRAM

---

### REVISION HISTORY

<u>Revision</u>	<u>Description</u>	<u>Issue Date</u>
Rev. 1.12	Initial Issue	May 15, 2012

### FEATURES

- Fast access time : 55ns
- Low power consumption:  
Operating current : 30mA (TYP.)  
Standby current : 1 $\mu$ A (TYP.) SL-version
- Single 2.7V ~ 3.6V power supply
- All inputs and outputs TTL compatible
- Fully static operation
- Tri-state output
- Data retention voltage : 1.5V (MIN.)
- **Green package available**
- Package : 32-pin 450 mil SOP
  - 32-pin 8mm x 20mm TSOP-I
  - 32-pin 8mm x 13.4mm STSOP
  - 36-ball 6mm x 8mm TFBGA
  - 32-pin 600 mil P-DIP
  - 32-pin 400 mil TSOP-II

### GENERAL DESCRIPTION

The AS6C4008A is a 4,194,304-bit low power CMOS static random access memory organized as 524,288 words by 8 bits. It is fabricated using very high performance, high reliability CMOS technology. Its standby current is stable within the range of operating temperature.

The AS6C4008A is well designed for very low power system applications, and particularly well suited for battery back-up nonvolatile memory application.

The AS6C4008A operates from a single power supply of 2.7V ~ 3.6V and all inputs and outputs are fully TTL compatible

### PRODUCT FAMILY

Product Family	Operating Temperature	Vcc Range	Speed	Power Dissipation	
				Standby( $I_{SB1}$ , TYP.)	Operating( $I_{CC}$ , TYP.)
AS6C4008A	-40 ~ 85°C	2.7 ~ 3.6V	55ns	1 $\mu$ A(SL)	30mA

### FUNCTIONAL BLOCK DIAGRAM

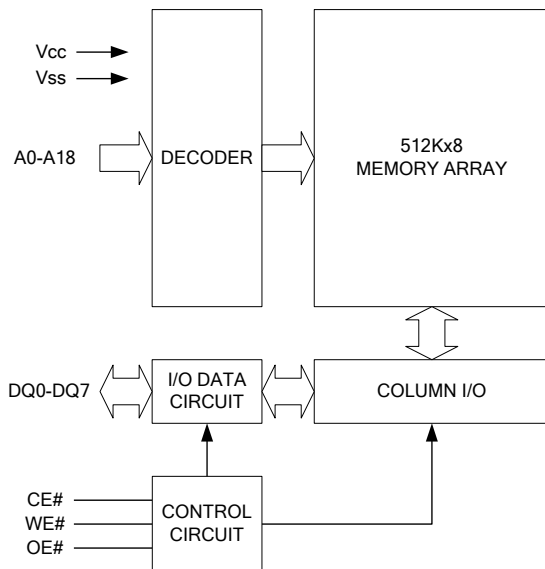

### PIN DESCRIPTION

SYMBOL	DESCRIPTION
A0 - A18	Address Inputs
DQ0 - DQ7	Data Inputs/Outputs
CE#	Chip Enable Inputs
WE#	Write Enable Input
OE#	Output Enable Input
Vcc	Power Supply
Vss	Ground
NC	No Connection

### PIN CONFIGURATION

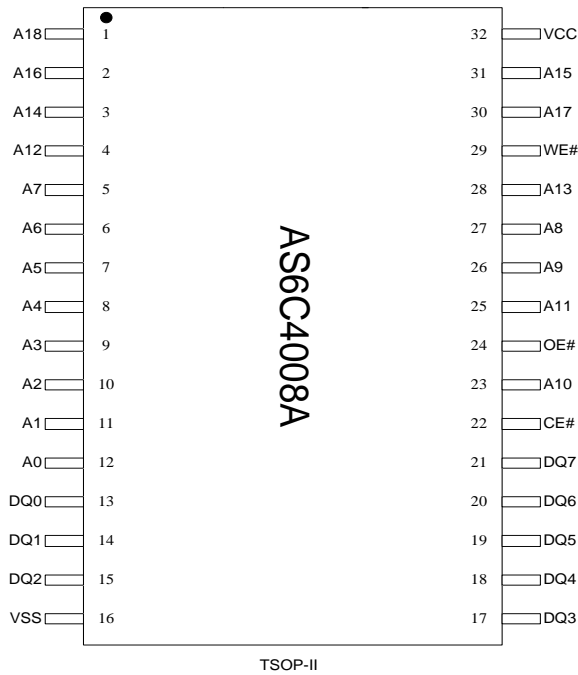
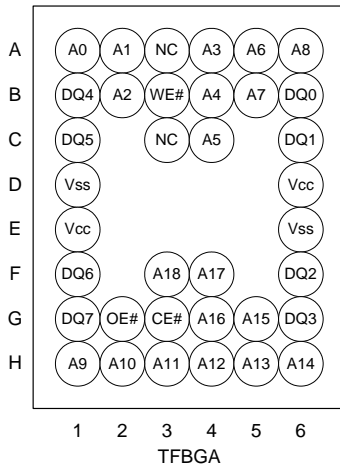
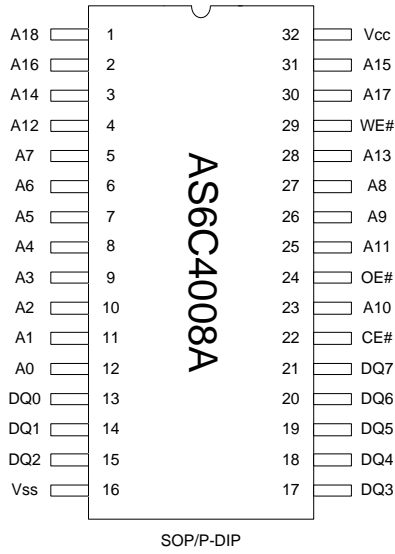



Rev. 1.12

# AS6C4008A

## 512K X 8 BIT LOW POWER CMOS SRAM

### ABSOLUTE MAXIMUM RATINGS\*

PARAMETER	SYMBOL	RATING	UNIT
Voltage on Vcc relative to Vss	V <sub>T1</sub>	-0.5 to 4.6	V
Voltage on any other pin relative to Vss	V <sub>T2</sub>	-0.5 to V <sub>CC</sub> +0.5	V
Operating Temperature	T <sub>A</sub>	-40 to 85(I grade)	°C
Storage Temperature	T <sub>STG</sub>	-65 to 150	°C
Power Dissipation	P <sub>D</sub>	1	W
DC Output Current	I <sub>OUT</sub>	50	mA

\*Stresses greater than those listed under "Absolute Maximum Ratings" may cause permanent damage to the device. This is a stress rating only and functional operation of the device or any other conditions above those indicated in the operational sections of this specification is not implied. Exposure to the absolute maximum rating conditions for extended period may affect device reliability.

### TRUTH TABLE

MODE	CE#	OE#	WE#	I/O OPERATION	SUPPLY CURRENT
Standby	H	X	X	High-Z	I <sub>SB</sub> , I <sub>SB1</sub>
Output Disable	L	H	H	High-Z	I <sub>CC</sub> , I <sub>CC1</sub>
Read	L	L	H	D <sub>OUT</sub>	I <sub>CC</sub> , I <sub>CC1</sub>
Write	L	X	L	D <sub>IN</sub>	I <sub>CC</sub> , I <sub>CC1</sub>

Note: H = V<sub>IH</sub>, L = V<sub>IL</sub>, X = Don't care.

### DC ELECTRICAL CHARACTERISTICS

PARAMETER	SYMBOL	TEST CONDITION		MIN.	TYP. <sup>4</sup>	MAX.	UNIT	
Supply Voltage	V <sub>CC</sub>			2.7	3.0	3.6	V	
Input High Voltage	V <sub>IH</sub> <sup>1</sup>			2.2	-	V <sub>CC</sub> +0.3	V	
Input Low Voltage	V <sub>IL</sub> <sup>2</sup>			- 0.2	-	0.6	V	
Input Leakage Current	I <sub>LI</sub>	V <sub>CC</sub> ≥ V <sub>IN</sub> ≥ V <sub>SS</sub>		- 1	-	1	μA	
Output Leakage Current	I <sub>LO</sub>	V <sub>CC</sub> ≥ V <sub>OUT</sub> ≥ V <sub>SS</sub> , Output Disabled		- 1	-	1	μA	
Output High Voltage	V <sub>OH</sub>	I <sub>OH</sub> = -1mA		2.2	2.7	-	V	
Output Low Voltage	V <sub>OL</sub>	I <sub>OL</sub> = 2mA		-	-	0.4	V	
Average Operating Power supply Current	I <sub>CC</sub>	Cycle time = Min. CE# = V <sub>IL</sub> and I <sub>I/O</sub> = 0mA Other pins at V <sub>IL</sub> or V <sub>IH</sub>	- 55	-	30	40	mA	
	I <sub>CC1</sub>	Cycle time = 1μs CE# ≤ 0.2V and I <sub>I/O</sub> = 0mA Other pins at 0.2V or V <sub>CC</sub> -0.2V		-	4	5	mA	
Standby Power Supply Current	I <sub>SB</sub>	CE# = V <sub>IH</sub> or CE2 = V <sub>IL</sub> , other pins at V <sub>IL</sub> or V <sub>IH</sub>		-	0.3	1.25	mA	
	I <sub>SB1</sub>	CE# ≥ V <sub>CC</sub> -0.2V Others at 0.2V or V <sub>CC</sub> - 0.2V	SLI <sup>5</sup>	25°C	-	1	3	μA
				40°C	-	1	3	μA
			SLI		-	1	12	μA

## Notes:

- V<sub>IH</sub>(max) = V<sub>CC</sub> + 3.0V for pulse width less than 10ns.
- V<sub>IL</sub>(min) = V<sub>SS</sub> - 3.0V for pulse width less than 10ns.
- Over/Undershoot specifications are characterized, not 100% tested.
- Typical values are included for reference only and are not guaranteed or tested.  
Typical values are measured at V<sub>CC</sub> = V<sub>CC</sub>(TYP.) and T<sub>A</sub> = 25°C
- This parameter is measured at V<sub>CC</sub> = 3.0V

### CAPACITANCE (T<sub>A</sub> = 25°C, f = 1.0MHz)

PARAMETER	SYMBOL	MIN.	MAX	UNIT
Input Capacitance	C <sub>IN</sub>	-	6	pF
Input/Output Capacitance	C <sub>I/O</sub>	-	8	pF

Note : These parameters are guaranteed by device characterization, but not production tested.

### AC TEST CONDITIONS

Input Pulse Levels	0.2V to V <sub>CC</sub> - 0.2V
Input Rise and Fall Times	3ns
Input and Output Timing Reference Levels	1.5V
Output Load	C <sub>L</sub> = 30pF + 1TTL, I <sub>OH</sub> /I <sub>OL</sub> = -1mA/2mA

### AC ELECTRICAL CHARACTERISTICS

#### (1) READ CYCLE

PARAMETER	SYM.	AS6C4008A-55		UNIT
		MIN.	MAX.	
Read Cycle Time	t <sub>RC</sub>	55	-	ns
Address Access Time	t <sub>AA</sub>	-	55	ns
Chip Enable Access Time	t <sub>ACE</sub>	-	55	ns
Output Enable Access Time	t <sub>OE</sub>	-	30	ns
Chip Enable to Output in Low-Z	t <sub>CLZ</sub> *	10	-	ns
Output Enable to Output in Low-Z	t <sub>OLZ</sub> *	5	-	ns
Chip Disable to Output in High-Z	t <sub>CHZ</sub> *	-	20	ns
Output Disable to Output in High-Z	t <sub>OHZ</sub> *	-	20	ns
Output Hold from Address Change	t <sub>OH</sub>	10	-	ns

#### (2) WRITE CYCLE

PARAMETER	SYM.	AS6C4008A-55		UNIT
		MIN.	MAX.	
Write Cycle Time	t <sub>WC</sub>	55	-	ns
Address Valid to End of Write	t <sub>AW</sub>	50	-	ns
Chip Enable to End of Write	t <sub>CW</sub>	50	-	ns
Address Set-up Time	t <sub>AS</sub>	0	-	ns
Write Pulse Width	t <sub>WP</sub>	45	-	ns
Write Recovery Time	t <sub>WR</sub>	0	-	ns
Data to Write Time Overlap	t <sub>DW</sub>	25	-	ns
Data Hold from End of Write Time	t <sub>DH</sub>	0	-	ns
Output Active from End of Write	t <sub>OW</sub> *	5	-	ns
Write to Output in High-Z	t <sub>WHZ</sub> *	-	20	ns

\*These parameters are guaranteed by device characterization, but not production tested.

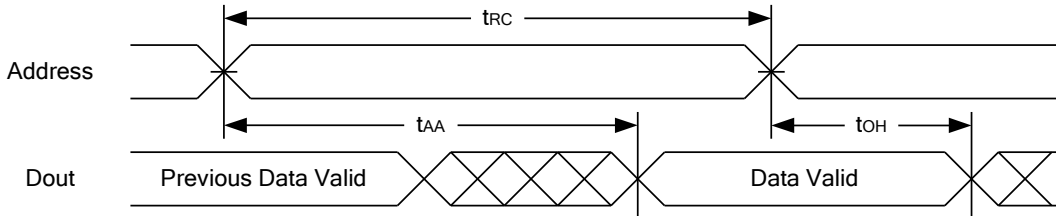
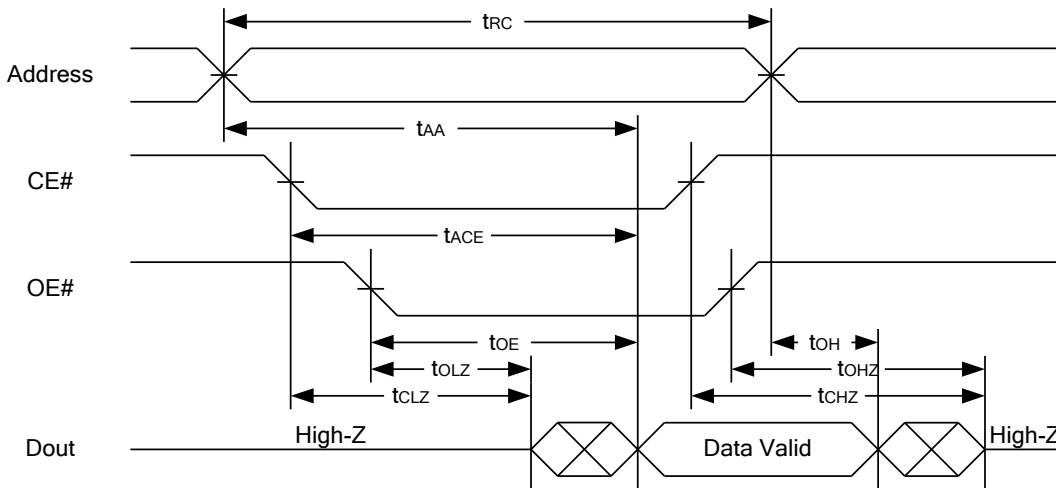
**TIMING WAVEFORMS**
**READ CYCLE 1 (Address Controlled) (1,2)**

**READ CYCLE 2 (CE# and OE# Controlled) (1,3,4,5)**

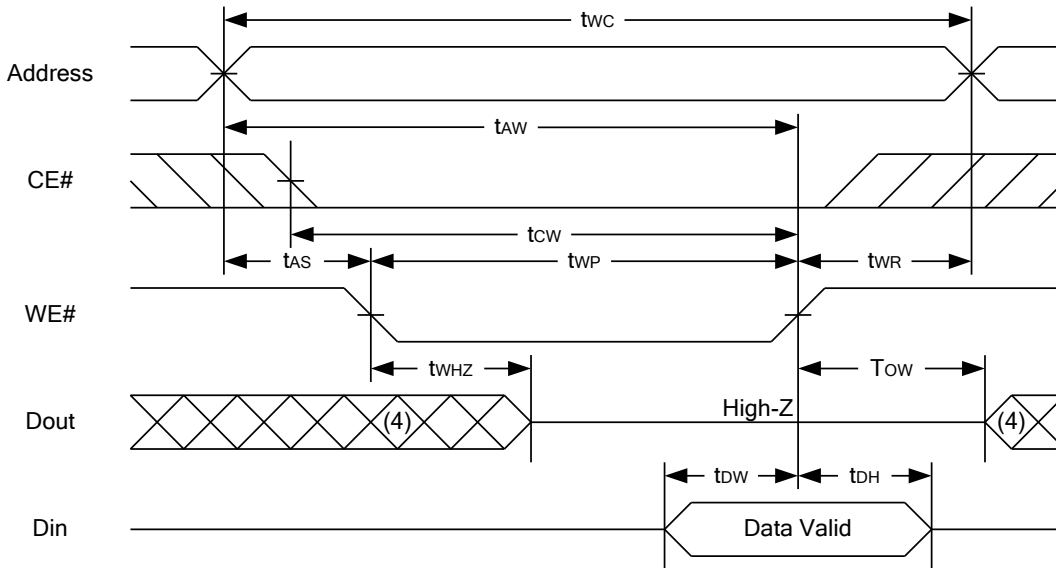
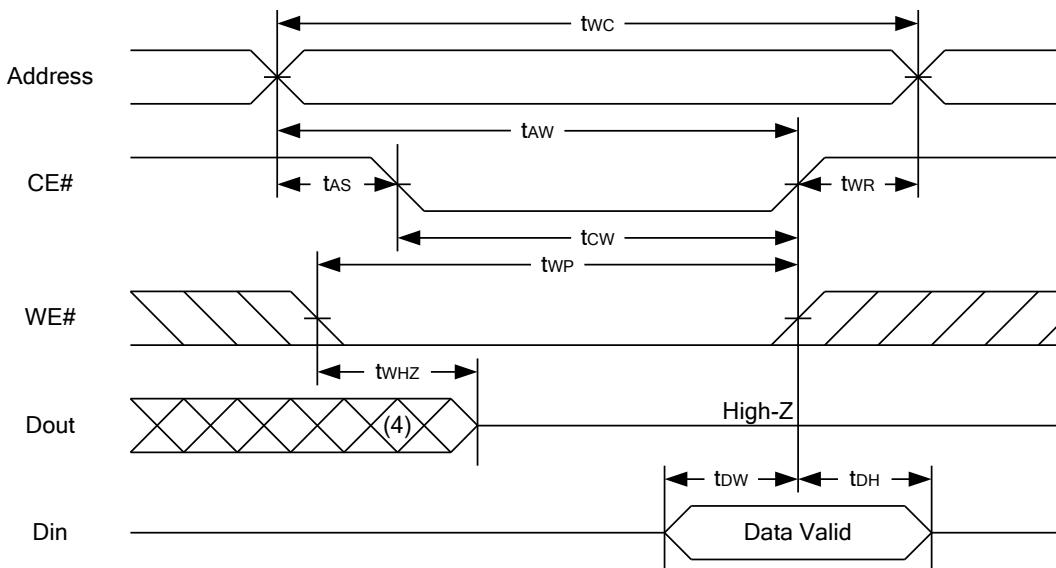
**Notes :**

1. WE# is high for read cycle.
2. Device is continuously selected OE# = low, CE# = low.
3. Address must be valid prior to or coincident with CE# = low,; otherwise tAA is the limiting parameter.
4. tCLZ, tOLZ, tCHZ and tOHZ are specified with CL = 5pF. Transition is measured ±500mV from steady state.
5. At any given temperature and voltage condition, tCHZ is less than tCLZ , tOHZ is less than tOLZ.

**WRITE CYCLE 1 (WE# Controlled) (1,2,3,5,6)**

**WRITE CYCLE 2 (CE# Controlled) (1,2,5,6)**

**Notes :**

1. WE#, CE# must be high during all address transitions.
2. A write occurs during the overlap of a low CE#, low WE#.
3. During a WE# controlled write cycle with OE# low,  $t_{wp}$  must be greater than  $t_{whz} + t_{dw}$  to allow the drivers to turn off and data to be placed on the bus.
4. During this period, I/O pins are in the output state, and input signals must not be applied.
5. If the CE# low transition occurs simultaneously with or after WE# low transition, the outputs remain in a high impedance state.
6.  $t_{ow}$  and  $t_{whz}$  are specified with  $C_L = 5pF$ . Transition is measured  $\pm 500mV$  from steady state.

### DATA RETENTION CHARACTERISTICS

PARAMETER	SYMBOL	TEST CONDITION	MIN.	TYP.	MAX.	UNIT		
VCC for Data Retention	V <sub>DR</sub>	CE# ≥ V <sub>CC</sub> - 0.2V	1.5	-	3.6	V		
Data Retention Current	I <sub>DR</sub>	V <sub>CC</sub> = 1.5V CE# ≥ V <sub>CC</sub> - 0.2V Other pins at 0.2V or V <sub>CC</sub> -0.2V	SLI	25°C	-	0.5	2.5	μA
				40°C	-	0.5	2.5	μA
		SLI		-	0.5	10	μA	
Chip Disable to Data Retention Time	t <sub>CDR</sub>	See Data Retention Waveforms (below)	0	-	-	ns		
Recovery Time	t <sub>r</sub>		t <sub>RC</sub> *	-	-	ns		

t<sub>RC</sub>\* = Read Cycle Time

### DATA RETENTION WAVEFORM

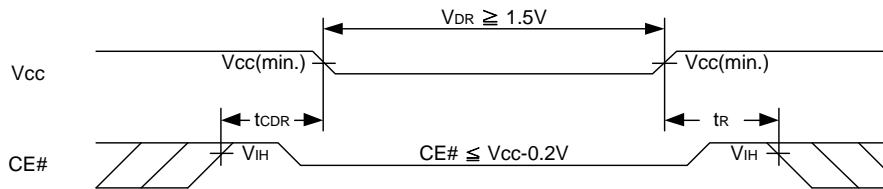

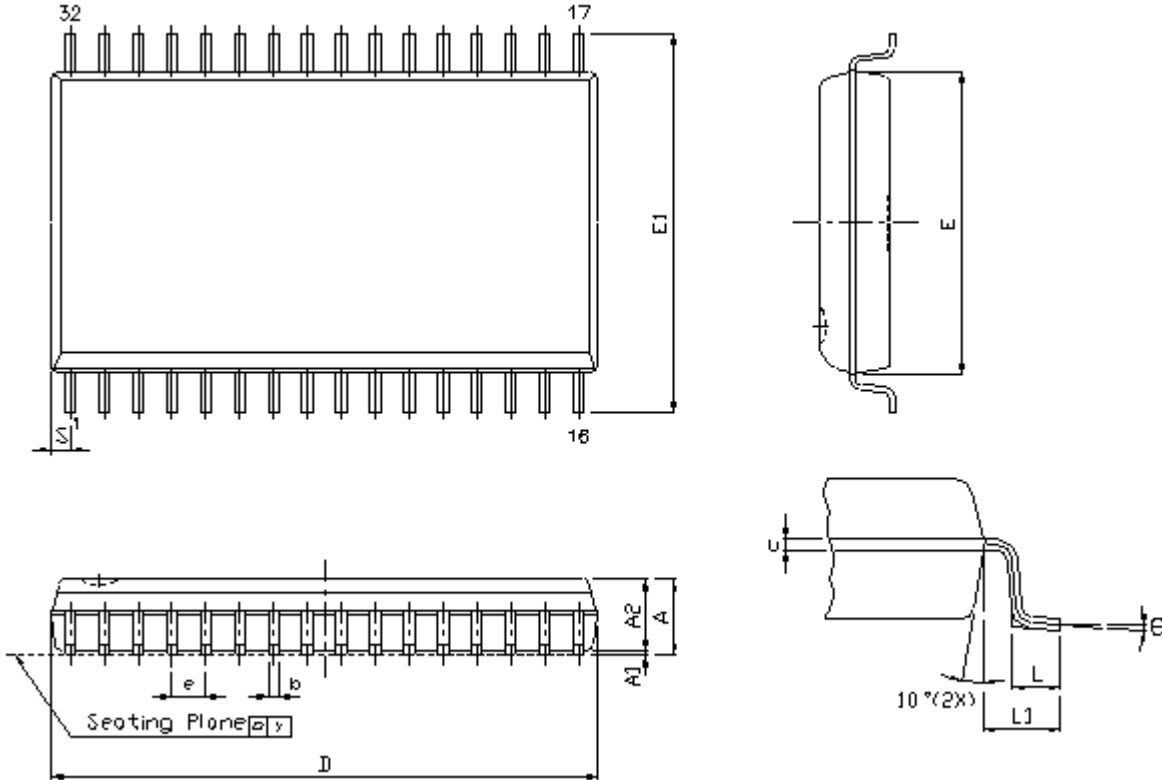
**PACKAGE OUTLINE DIMENSION**
**32 pin 450 mil SOP Package Outline Dimension**

SYM.	UNIT	INCH.(BASE)	MM(REF)
A		0.120(MAX)	3.048(MAX)
A1		0.004(MIN)	0.102(MIN)
A2		0.116(MAX)	2.946(MAX)
b		0.016(TYP)	0.406(TYP)
c		0.008(TYP)	0.203(TYP)
D		0.817(MAX)	20.75(MAX)
E		0.445±0.006	11.303±0.152
E1		0.555±0.025	14.097±0.635
e		0.050(TYP)	1.270(TYP)
L		0.033±0.017	0.838±0.432
L1		0.055±0.008	1.397±0.203
S		0.026(MAX)	0.660(MAX)
y		0.004(MAX)	0.101(MAX)
Θ		0° -10°	0° -10°

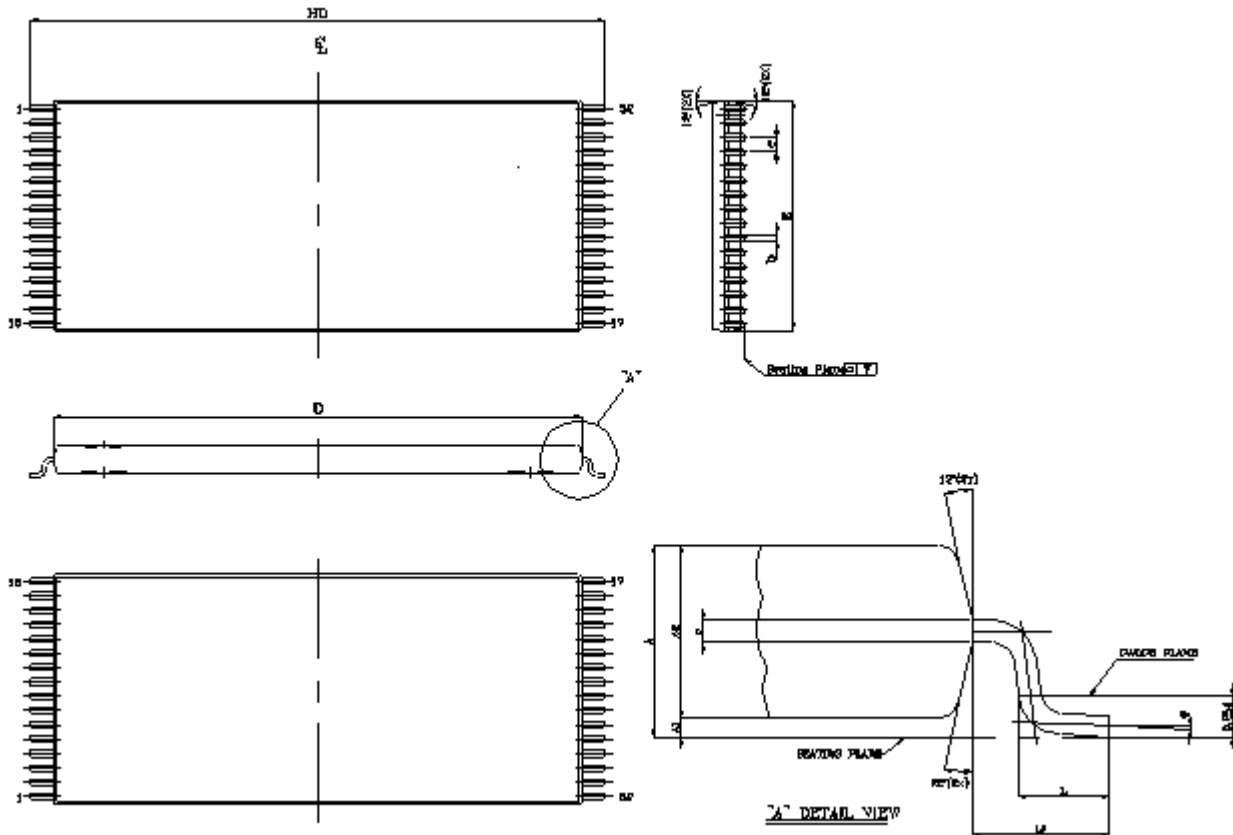
**32 pin 8mm x 20mm TSOP-I Package Outline Dimension**

SYM.	UNIT	INCH(BASE)	MM(REF)
A		0.047 (MAX)	1.20 (MAX)
A1		0.004 ±0.002	0.10 ±0.05
A2		0.039 ±0.002	1.00 ±0.05
b		0.009 ±0.002	0.22 ±0.05
c		0.006 ±0.002	0.155 ±0.055
D		0.724 ±0.008	18.40 ±0.20
E		0.315 ±0.008	8.00 ±0.20
e		0.020 (TYP)	0.50 (TYP)
HD		0.787 ±0.008	20.00 ±0.20
L		0.024 ±0.004	0.60 ±0.10
L1		0.0315 ±0.004	0.08 ±0.10
y		0.003 (MAX)	0.08 (MAX)
∅		0°~5°	0°~5°

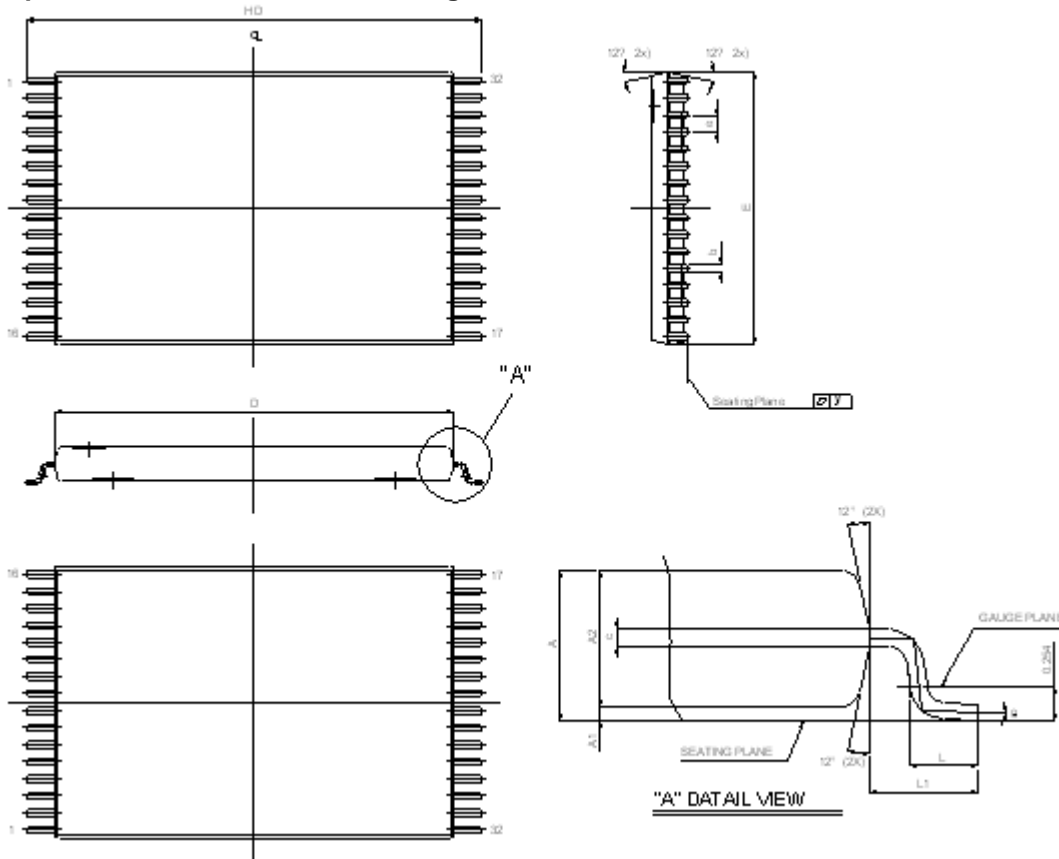
**32 pin 8mm x 13.4mm STSOP Package Outline Dimension**

UNIT SYM.	INCH(BASE)	MM(REF)
A	0.049 (MAX)	1.25 (MAX)
A1	0.004 ±0.002	0.10 ±0.05
A2	0.039 ±0.002	1.00 ±0.05
b	0.009 ±0.002	0.22 ±0.05
c	0.006 ±0.002	0.155 ±0.055
D	0.465 ±0.008	11.80 ±0.20
E	0.315 ±0.008	8.00 ±0.20
e	0.020 (TYP)	0.50 (TYP)
HD	0.528±0.008	13.40 ±0.20.
L	0.02 ±0.008	0.50 ±0.20
L1	0.031 ±0.005	0.8 ±0.125
y	0.003 (MAX)	0.076 (MAX)
Θ	0°~5°	0°~5°

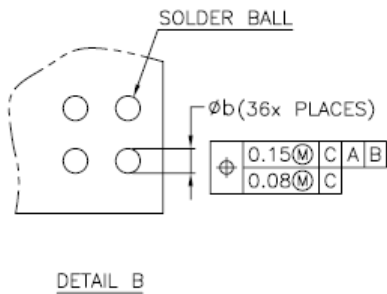
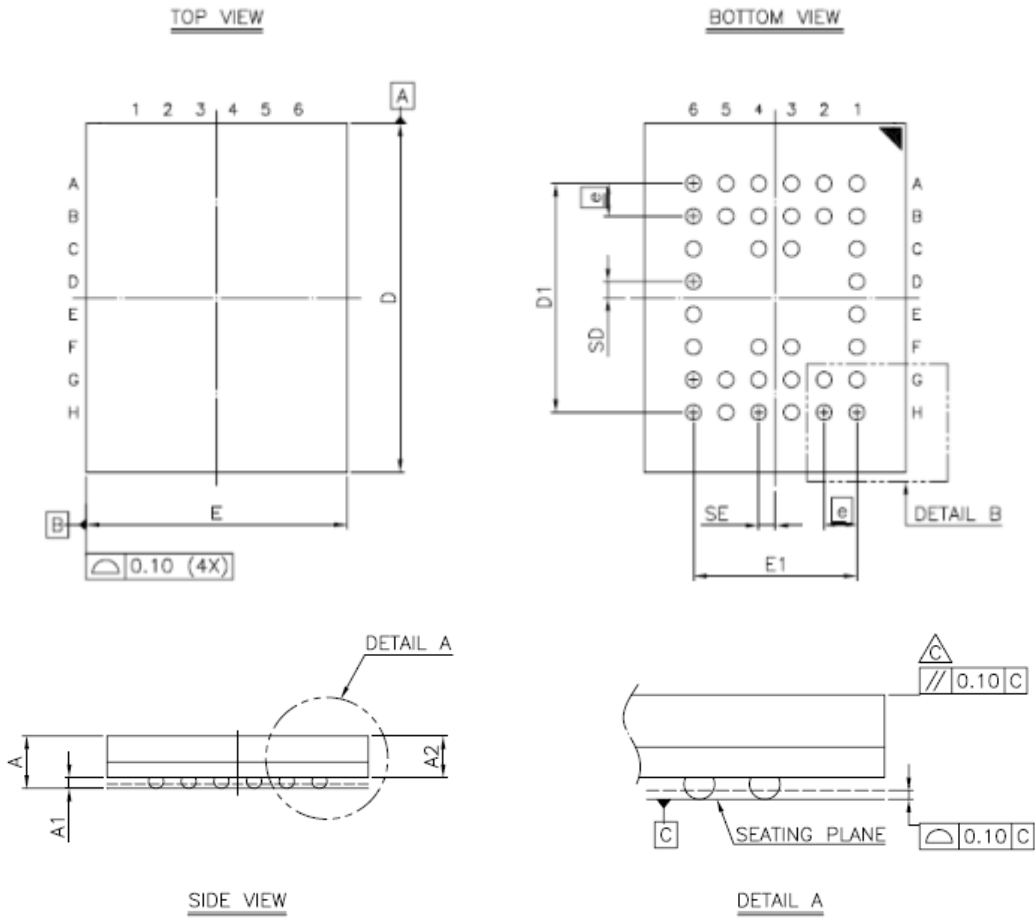
**36 ball 6mm x 8mm TFBGA Package Outline Dimension**

SYM.	DIMENSION (mm)			DIMENSION (inch)		
	MIN.	NOM.	MAX.	MIN.	NOM.	MAX.
A	—	—	1.20	—	—	0.047
A1	0.20	0.25	0.30	0.008	0.010	0.012
A2	—	—	0.94	—	—	0.037
b	0.30	0.35	0.40	0.012	0.014	0.016
D	7.95	8.00	8.05	0.313	0.315	0.317
D1	5.25 BSC			0.207 BSC		
E	5.95	6.00	6.05	0.234	0.236	0.238
E1	3.75 BSC			0.148 BSC		
SE	0.375 TYP			0.015 TYP		
SD	0.375 TYP			0.015 TYP		
SE	0.75 BSC			0.030 BSC		

## NOTE:

1. CONTROLLING DIMENSION : MILLIMETER.
2. REFERENCE DOCUMENT : JEDEC MO-207.

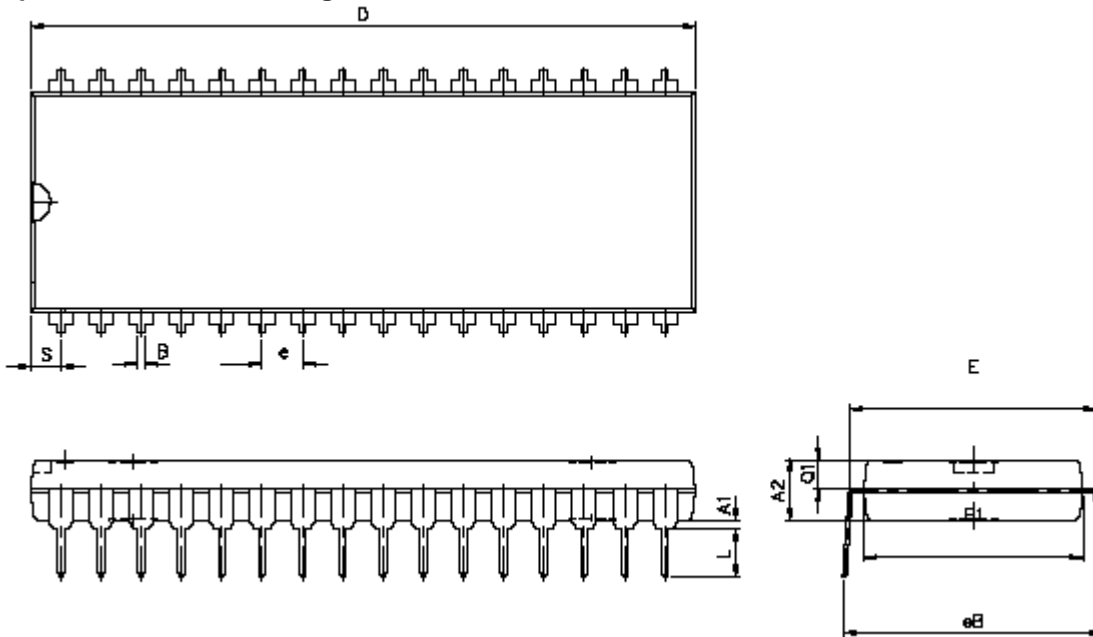
**32 pin 600 mil P-DIP Package Outline Dimension**

SYM.	UNIT	INCH(BASE)	MM(REF)
A1		0.015(MIN)	0.381(MIN)
A2		0.155±0.005	3.937±0.127
B		0.018±0.005	0.457±0.127
D		1.650±0.01	41.910±0.254
E		0.600±0.010	15.240±0.254
E1		0.545±0.005	13.843±0.127
e		0.100(TYP)	2.540(TYP)
eB		0.650±0.020	16.510±0.508.
L		0.158±0.043	4.013±1.092
S		0.075±0.010	1.905±0.254
Q1		0.070±0.005	1.778±0.127

Note : D/E1/S dimension do not include mold flash.

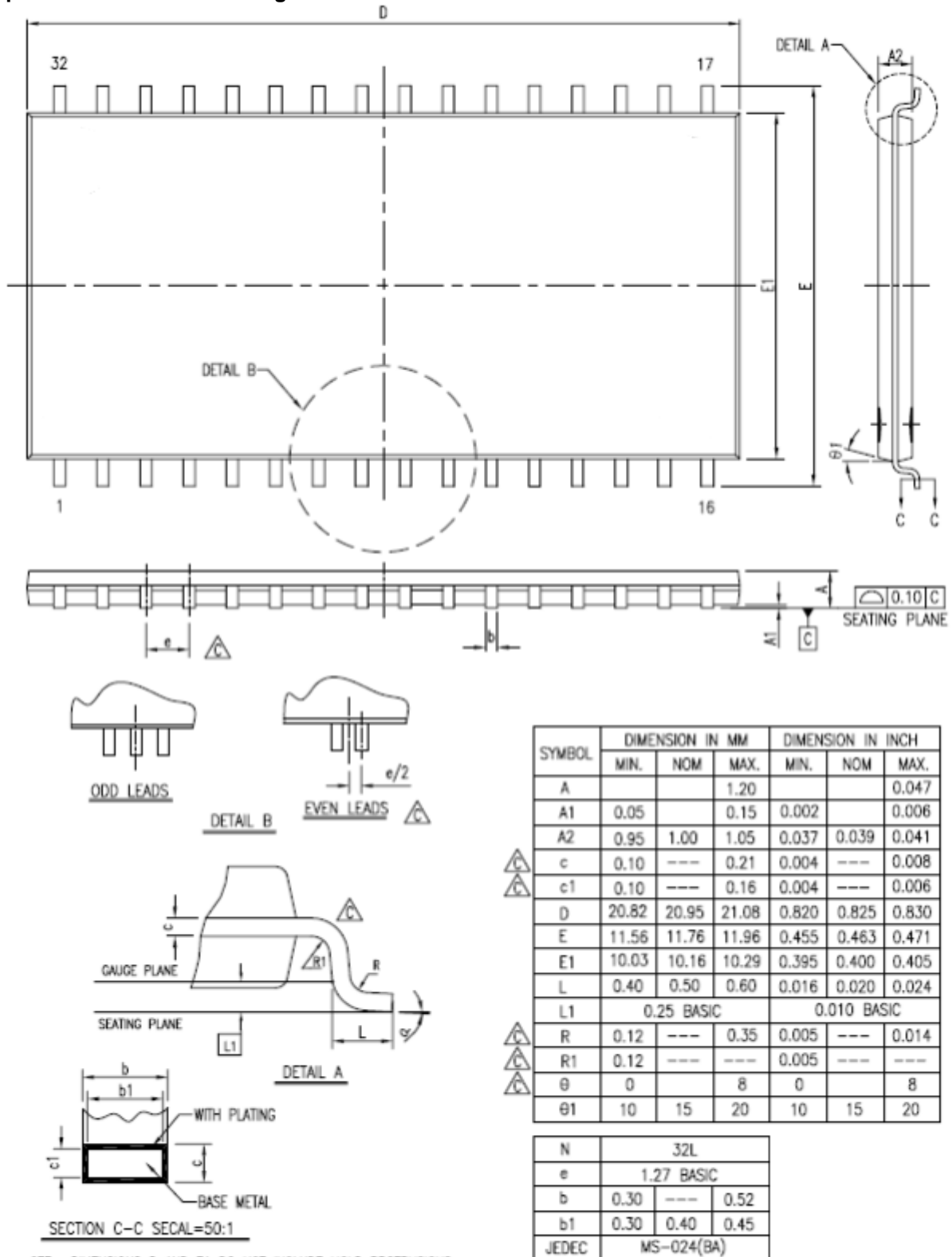
**32-pin 400mil TSOP-II Package Outline Dimension**

NOTE: DIMENSIONS D AND E1 DO NOT INCLUDE MOLD PROTRUSIONS.  
D AND E1 ARE MAXIMUM PLASTIC BODY SIZE DIMENSIONS INCLUDING MOLD MISMATCH.

### ORDERING INFORMATION



Alliance	Organization	VCC	Package	Operating Temp	Speed ns
AS6C4008A-55PCN	512k x 8	3V	32pin 600mil DIP	Commercial - 0°C to 70°C	55
AS6C4008A-55SIN	512k x 8	3V	32pin 450mil SOP	Industrial - -40°C to 85°C	55
AS6C4008A-55TIN	512k x 8	3V	32pin TSOP 1 (8 x 20 mm)	Industrial - -40°C to 85°C	55
AS6C4008A-55STIN	512k x 8	3V	32pin sTSOP (8 x 13.4 mm)	Industrial - -40°C to 85°C	55
AS6C4008A-55BIN	512k x 8	3V	36pin TFBGA (6mm x 8mm)	Industrial - -40°C to 85°C	55
AS6C4008A-55ZIN	512k x 8	3V	32pin 400mil TSOP 11	Industrial - -40°C to 85°C	55

### PART NUMBERING SYSTEM

AS6C	4008	-55	X	X	N
Low power SRAM prefix	Device Number 40 = 4M 08 = by 8	Access Time	Package Options: P = 32 pin 600 mil P-DIP S = 32 pin 450 mil SOP T = 32 pin TSOP 1 (8mm x 20mm) Z = 32 pin 400 mil TSOP 11 ST = 32 pin sTSOP (8mm x 13.4mm) B = 36 pin TFBGA (6mm x 8mm)	Temperature Range: C = Commercial (0°C to +70°C) I = Industrial (-40°C to +85°C)	N = Lead Free ROHS Compliant Part

## Looking for pricing, stock, or lifecycle information?

Click below to explore more details on WIN SOURCE:

-  [View AS6C4008A-55STIN on WIN SOURCE](#)
-  [Alliance Memory, Inc. Information](#)

## Optimize Your Supply Chain with WIN SOURCE Solutions

-  Global Sourcing Solution
-  Obsolete Management
-  Cost Control Management
-  Shortage Management
-  Alternative Solution
-  Excess Inventory Management