



**THE DATASHEET OF
AL8400QSE-7**



LINEAR LED DRIVER-CONTROLLER with 200mV CURRENT SENSE VOLTAGE and AUTOMOTIVE GRADE

Description

The AL8400 is a 5-terminal adjustable Linear LED driver-controller offering excellent temperature stability and output handling capability. The AL8400 simplifies the design of linear and isolated LED drivers. With its low 200mV current sense FB pin, it controls the regulation of LED current with minimal power dissipation when compared to traditional linear LED drivers. This makes it ideal for medium to high current LED driving.

The AL8400 open-collector output can operate from 0.2V to 18V enabling it to drive external MOSFET and Bipolar transistors. This enables the MOSFET and Bipolar selection to be optimized for the chosen application. It also provides the capability to drive longer LED chains, by tapping V_{CC} from the chain, where the chain voltage may exceed 18V.

It is available in the space saving low profile SOT353 package.

The AL8400Q is Automotive Grade and is AEC-Q100 Grade 1 qualified.

Applications

- Isolated Offline LED Lamps
- Linear LED Driver
- LED Signs
- Instrumentation Illumination

- Notes:
1. EU Directive 2002/95/EC (RoHS) & 2011/65/EU (RoHS 2) compliant. All applicable RoHS exemptions applied.
 2. See <http://www.diodes.com> for more information about Diodes Incorporated's definitions of Halogen- and Antimony-free, "Green" and Lead-free.
 3. Halogen- and Antimony-free "Green" products are defined as those which contain <900ppm bromine, <900ppm chlorine (<1500ppm total Br + Cl) and <1000ppm antimony compounds.

Pin Assignments



Features

- Low Reference Voltage (V_{FB} = 0.2V)
- -40 to +125°C Temperature Range
- 3% Reference Voltage Tolerance at +25°C
- Low Temperature Drift
- 0.2V to 18V Open-Collector Output
- High Power Supply Rejection:
 - (> 45dB at 300kHz)
- AL8400QSE-7 Automotive Grade qualified to AEC-Q100 Grade 1
- SOT353: Available in "Green" Molding Compound (No Br, Sb)
 - **Lead-Free Finish; RoHS Compliant (Notes 1 & 2)**
 - **Halogen and Antimony Free. "Green" Device (Note 3)**

Typical Applications Circuit

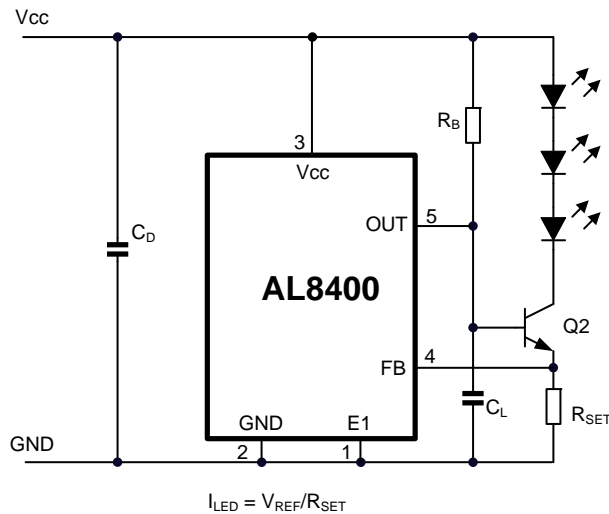

Pin Descriptions

Pin Number	Name	Function
1	E1	Emitter Connection. Connect to GND.
2	GND	Analog Ground. Ground return for reference and amplifier. Connect to E1.
3	V _{CC}	Supply Input. Connect a 0.47μF ceramic capacitor close to the device from V _{CC} to GND.
4	FB	Feedback Input. Regulates to 200mV nominal.
5	OUT	Output. Connect a capacitor close to device between OUT and GND. See the <i>Applications Information</i> section.

Functional Block Diagram

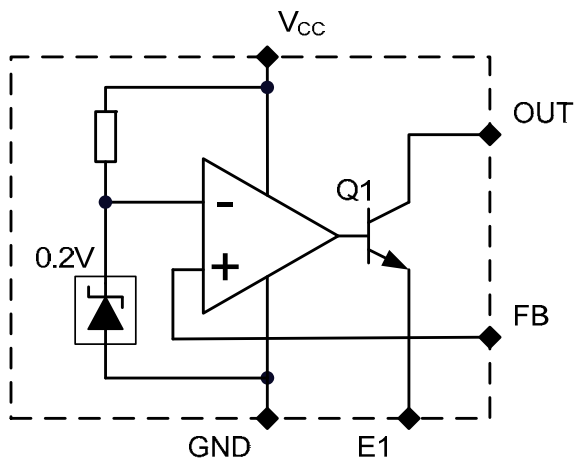

Figure 1 Block Diagram

Absolute Maximum Ratings (@T_A = +25°C, unless otherwise specified.)

Symbol	Parameter	Rating	Unit
V _{CC}	Supply Voltage Relative to GND	20	V
V _{OUT}	OUT Voltage Relative to GND	20	V
V _{FB}	FB Voltage Relative to GND	20	V
V _{E1}	E1 Voltage Relative to GND	-0.3 to +0.3	V
T _J	Operating Junction Temperature	-40 to 150	°C
T _{ST}	Storage Temperature	-55 to 150	°C

These are stress ratings only. Operation outside the absolute maximum ratings may cause device failure. Operation at the absolute maximum rating for extended periods may reduce device reliability.

Package Thermal Data

Package	θ _{JA}	P _{DIS} T _A = +25°C, T _J = +150°C
SOT353	400°C/W	310mW

Recommended Operating Conditions (@ $T_A = +25^\circ\text{C}$, unless otherwise specified.)

Symbol	Parameter	Min	Max	Units
V_{CC}	Supply Voltage Range	2.2	18	V
V_{OUT}	OUT Voltage Range	0.2	18	
I_{OUT}	OUT Pin Current	0.3	15	mA
T_A	Operating Ambient Temperature Range	-40	+125	$^\circ\text{C}$

Electrical Characteristics (Note 4) (@ $T_A = +25^\circ\text{C}$, $V_{CC} = 12\text{V}$, $V_{OUT} = V_{FB}$, $I_{OUT} = 1\text{mA}$, unless otherwise specified.)

Symbol	Parameter	Conditions	Min	Typ	Max	Units	
V_{FB}	Feedback Voltage		$T_A = +25^\circ\text{C}$	0.194	0.2	0.206	V
			$T_A = -40^\circ\text{C}$ to $+125^\circ\text{C}$	0.190		0.210	
FB_{LOAD}	Feedback Pin Load Regulation	$I_{OUT} = 1$ to 15mA	$T_A = +25^\circ\text{C}$		3.1	6	mV
			$T_A = -40^\circ\text{C}$ to $+125^\circ\text{C}$			10	
FB_{LINE}	Feedback Pin Line Regulation	$V_{CC} = 2.2\text{V}$ to 18V	$T_A = +25^\circ\text{C}$		0.1	1.5	mV
			$T_A = -40^\circ\text{C}$ to $+125^\circ\text{C}$			2	
FB_{OVR}	Output Voltage Regulation	$V_{OUT} = 0.2\text{V}$ to 18V , $I_{OUT} = 1\text{mA}$ (Ref. Figure 1)	$T_A = +25^\circ\text{C}$			2	mV
			$T_A = -40^\circ\text{C}$ to $+125^\circ\text{C}$			3	
I_{FB}	FB Input Bias Current	$V_{CC} = 18\text{V}$	$T_A = +25^\circ\text{C}$		-45		nA
			$T_A = -40^\circ\text{C}$ to $+125^\circ\text{C}$	-200		0	
I_{CC}	Supply Current	$V_{CC} = 2.2\text{V}$ to 18V , $I_{OUT} = 10\text{mA}$	$T_A = +25^\circ\text{C}$		0.48	1	mA
			$T_A = -40^\circ\text{C}$ to $+125^\circ\text{C}$			1.5	
$I_{OUT(LK)}$	OUT Leakage Current	$V_{CC} = 18\text{V}$, $V_{OUT} = 18\text{V}$, $V_{FB} = 0\text{V}$	$T_A = +25^\circ\text{C}$			0.1	μA
			$T_A = +125^\circ\text{C}$			1	
Z_{OUT}	Dynamic Output Impedance	$I_{OUT} = 1$ to 15mA , $f < 1\text{kHz}$	$T_A = +25^\circ\text{C}$		0.25	0.4	Ω
			$T_A = -40^\circ\text{C}$ to $+125^\circ\text{C}$			0.6	
PSRR	Power Supply Rejection Ratio	$f = 300\text{kHz}$, $V_{AC} = 0.3V_{PP}$	$T_A = +25^\circ\text{C}$		45		dB
BW	Amplifier Unity Gain Frequency		$T_A = +25^\circ\text{C}$		600		kHz
G	Amplifier Transconductance		$T_A = +25^\circ\text{C}$		4500		mA/V

Note: 4. Production testing of the device is performed at $+25^\circ\text{C}$. Functional operation of the device and parameters specified over the operating temperature range are guaranteed by design, characterization and process control.

Typical Characteristics

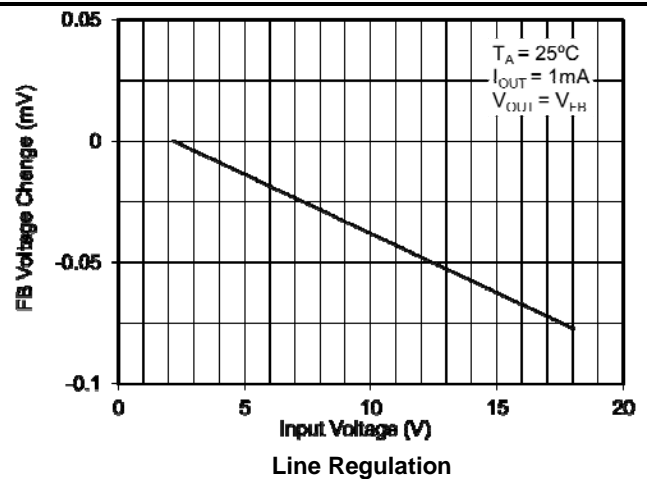
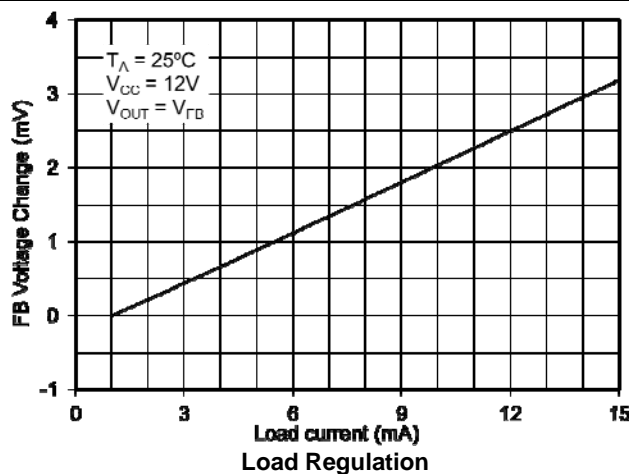

Typical Characteristics (cont.)

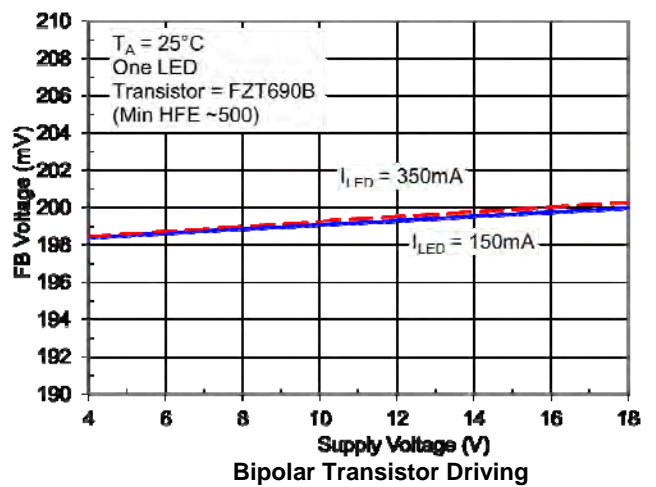
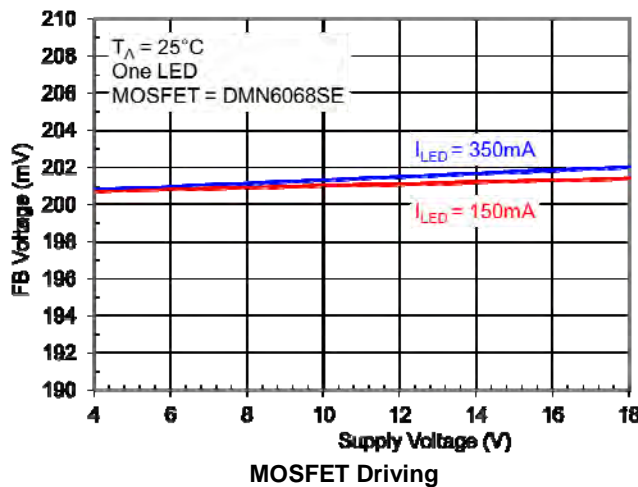
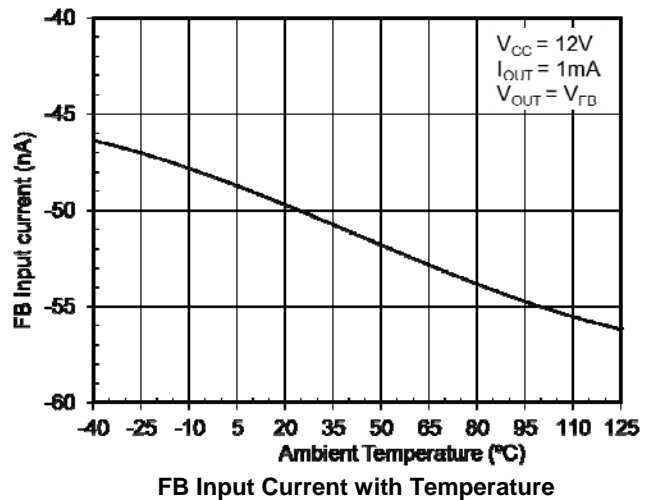
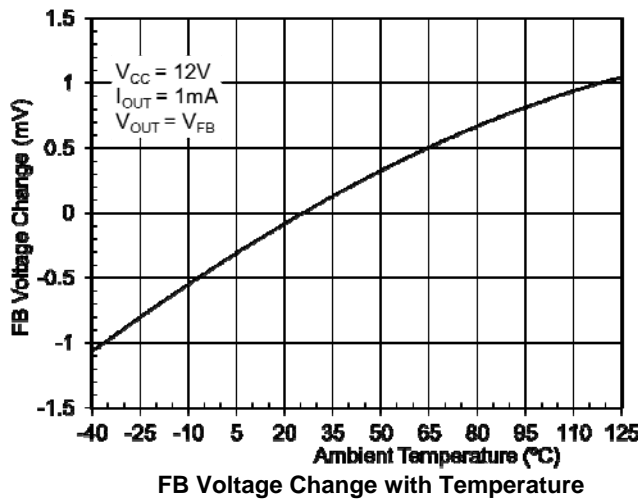
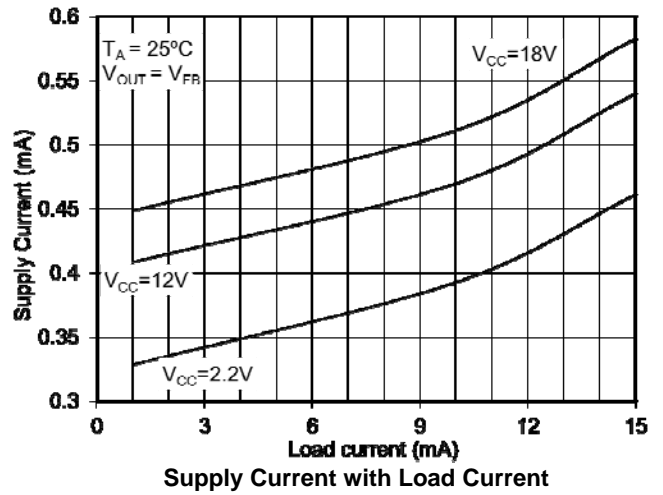
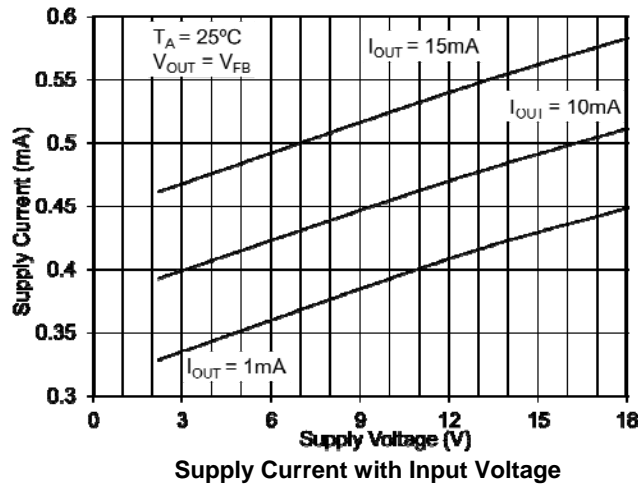

Application Information

Description

The AL8400 Linear LED driver controller uses an external pass element to drive the LEDs and uses its FB pin to sense the LED current through an external resistor R_{SET} . The pass element is driven by the AL8400's open collector OUT pin which allows the pass element to be either an NPN transistor or N-channel MOSFET. An external pull-up resistor, R_B , is required to be connected from the OUT pin to V_{CC} . This resistor supplies the output bias current of the AL8400 together with any current which the pass element requires.

In order to maintain the accuracy of the 200mV reference voltage on the FB pin the value of R_B should be set so that the OUT pin sinks 1mA.

Stability

As with all ICs, for best stability a 0.1µF minimum (X7R ceramic) power supply decoupling capacitor, C_D , connected between V_{CC} and Ground (See Figure 2) is recommended. C_D should be placed as close to the V_{CC} pin as possible < 5mm.

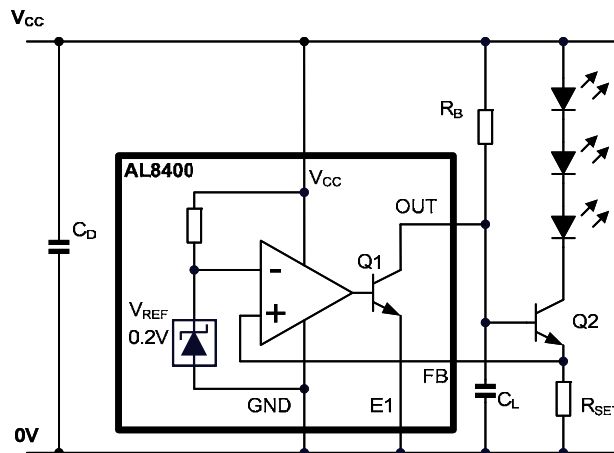

Figure 2 Application Circuit Using Bipolar Transistor

The AL8400 requires an output capacitor, C_L in Figure 2, to be connected from the OUT pin to Ground. This capacitor is required to compensate the current control loop of the AL8400.

This compensation capacitor must be placed as close to the OUT pin as possible < 5mm. If the PCB traces are too long, there is the possibility of oscillation at about 5MHz. The capacitors C_D and C_L must be mounted immediately adjacent to the AL8400, with direct connections to OUT, E1, GND and V_{CC} . The limit of 5mm provides a good margin for stability.

The value of capacitor C_L is determined from the value of the pull-up resistor R_B so that:

$$C_L \times R_B \geq 2ms$$

For example if $R_B = 1k\Omega$, then C_L must be 2µF or greater. The recommended capacitor type is X7R ceramic.

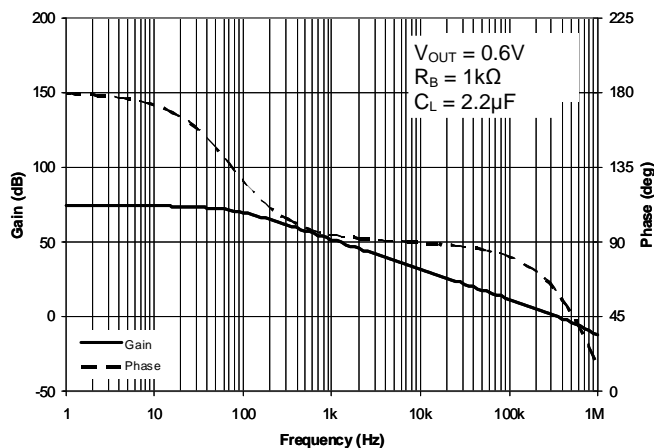

Figure 3 Gain and Phase vs. Frequency with $R_B = 1k\Omega$ and $C_L = 2.2\mu F$

Application Information (cont.)

Bipolar Transistor as the Pass Element

For driving currents in the region of about 50mA to about 400mA, the recommended NPN is DNLS320E in the SOT223 package. The high DC current gain of the DNLS320E is useful in this application, in order to minimize the current in R_B . The design procedure is as follows, referring to Figure 4.

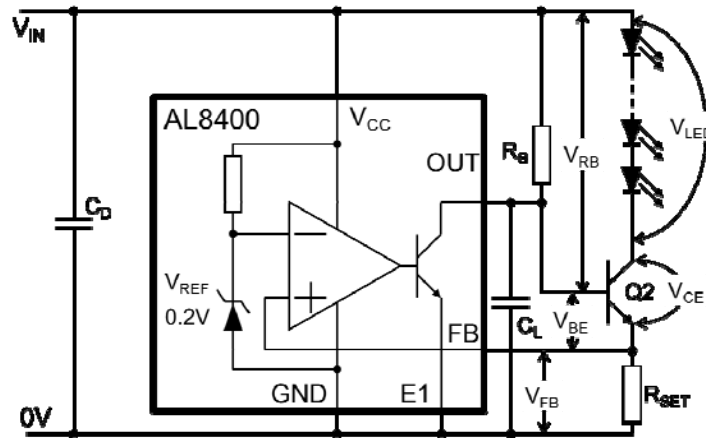

Figure 4 Application Circuit Using Bipolar Transistor

There are two important equations for the circuit:

LED Circuit Path:

1. $V_{CC} = (V_{LED} + V_{CE} + V_{FB})$ where V_{FB} is approximately the internal reference voltage of 200mV.

The maximum total LED voltage plus the reference voltage determines the minimum supply voltage. Substituting into equation 1 yields:

$$V_{CCmin} = V_{LEDmax} + V_{CEsat} + V_{FB} \text{ where } V_{LEDmax} \text{ is the maximum LED chain voltage.}$$

Control Drive Circuit Path

2. $V_{CC} = (V_{RB} + V_{BE} + V_{FB})$

For a bipolar transistor the voltage (V_{RB}) across bias resistor R_B consists of the base current of Q2 and the output current of the AL8400. So rearranging equation 2 yields the boundaries for allowable R_B values:

3. $R_{Bmax} = \frac{V_{CCmin} - V_{BEmax} - V_{FB}}{I_{OUTmin} + I_{Bmax}}$

4. $R_{Bmin} = \frac{V_{CCmax} - V_{BEmin} - V_{FB}}{I_{OUTmax} + I_{Bmin}}$

where I_{Bmax} is the maximum transistor base current

where I_{Bmin} is the minimum transistor base current

$$I_{Bmax} = \frac{I_{LED}}{h_{FEmin}}$$

$$I_{Bmin} = \frac{I_{LED}}{h_{FEmax}}$$

where h_{FEmin} is the minimum DC current gain of the transistor.

where h_{FEmax} is the maximum DC current gain of the transistor.

The value of R_B should be set somewhere between R_{Bmax} and R_{Bmin} with the target of trying to get I_{OUT} of the AL8400 close to 1mA for nominal conditions.

Once R_B has been determined the value for compensation capacitor, C_L , should be calculated.

$$C_L \approx \frac{2ms}{R_B}$$

Finally, the bipolar selection is also influenced by the maximum power dissipation

$$P_{TOT} = I_{LED} \times (V_{CC} - V_{LED} - V_{REF}) = I_{LED} \times V_{CE}$$

Since this determines the package choice (θ_{JA}) in order to keep the junction temperature below the maximum value allowed.

$$T_J = T_A + P_{TOT} \times \theta_{JA}$$

where

$T_{J(MAX)}$ is the maximum operating junction temperature,

T_A is the ambient temperature,

θ_{JA} is the junction to ambient thermal resistance.

Application Information (cont.)

Bipolar Example – Choosing R_B and C_L

The driver is required to control 3 series connected LEDs at 150mA \pm 10% from a 12V \pm 5% supply. Each LED has a forward voltage of 3V minimum and of 3.6V maximum.

From this information the minimum supply voltage is 11.4V and the maximum LED chain voltage is 10.8V. Rearranging equation 1 (page 7); the minimum voltage drop across the bipolar transistor is determined to be:

$$V_{CE} = V_{CCmin} - V_{LEDmax} - V_{FB} = 11.4V - 10.8V - 0.2V = 0.4V$$

We will use the DNLS320E bipolar transistor (Q2.)

R_{Bmax}

The DNLS320E datasheet table states:

$$V_{CE(SAT)max} = 0.1V \text{ at } I_C = 100mA, I_B = 0.5mA$$

$$h_{FEmin} = 500 \text{ @ } I_C = 100mA, V_{CE} = 2V;$$

The datasheet graph (see left) shows a very slow variation at 100mA, so a value of 500 is considered appropriate.

$$\text{Then } I_{Bmax} = \frac{150mA}{500} = 0.3mA$$

The minimum recommended I_{OUT} for AL8400 is 0.3mA and the maximum V_{BE} , according to the DNLS320E datasheet graph (Figure 6), is approximately 0.8V at -55°C.

From these and equation 3, the maximum allowed bias resistor value is:

$$R_{Bmax} = \frac{V_{CCmin} - V_{BEmax} - V_{FB}}{I_{OUTmin} + I_{Bmax}} = \frac{11.4 - 0.8 - 0.2}{0.0003 + 0.0003} = 17.3k\Omega$$

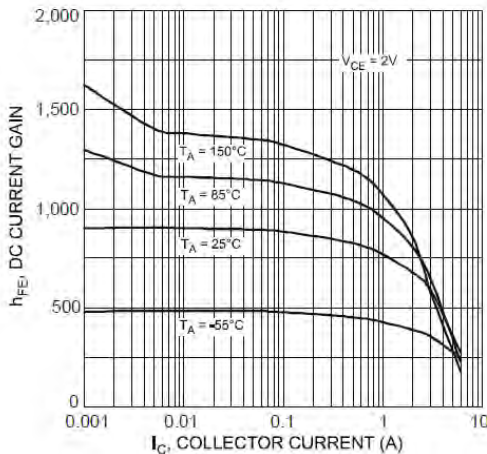

Figure 5 DNLS320E H_{FE} vs. I_C

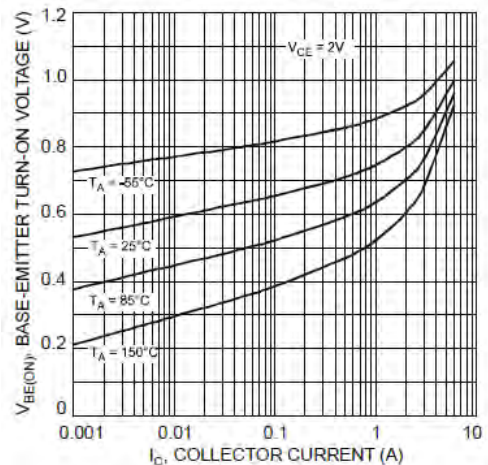

Figure 6 DNLS320E V_{BE} vs. I_C

Application Information (cont.)

Bipolar Example – Choosing R_B and C_L (cont.)

R_{Bmin}

To ensure that the output capability of the AL8400 is not exceeded at maximum V_{IN} , maximum h_{FE} and minimum V_{BE} , these values should be substituted back into the R_B equation to determine the minimum allowable value for R_B .

h_{FEmax} is about 1200 @ $I_C = 100mA$, and a temperature of +85°C (Figure 5) which results in:

$$I_{Bmin} = \frac{150}{1200} = 0.125mA$$

The maximum recommended I_{OUT} for AL8400 is 15mA. The minimum V_{BE} , according to the DNLS320E datasheet graph (Figure 6), is approximately 0.4V at 85°C and assuming $V_{CCmax} = 12.6V$, then from equation 4 the bias resistor value is:

$$R_{Bmin} = \frac{V_{CCmax} - V_{BEmin} - V_{FB}}{I_{OUTmax} + I_{Bmin}} = \frac{8.4 - 0.4 - 0.2}{0.015 + 0.000125} = 516\Omega$$

this is less than 17k Ω and so the AL8400 output current is within its ratings.

C_L

Choosing $R_B = 11k\Omega$ satisfies the requirements for the AL8400 conformance and sets approximately 1mA in the OUT pin. The required compensation capacitor can therefore be calculated from:

$$C_L \approx \frac{2ms}{11k\Omega} \approx 0.18\mu F \rightarrow 180nF$$

The value of R_{SET} is V_{REF}/I_{LED} so:

$$R_{SET} = 0.2/0.15 = 1.333\Omega \rightarrow \text{Choosing two } 2.7\Omega \text{ yields } 1.35\Omega \text{ giving an approximate } 1.3\% \text{ difference from target.}$$

Finally, the maximum power dissipation of the external bipolar transistor is:

$$P_{TOT} = I_{LED} \times V_{CEMAX} = I_{LED} \times (V_{CCmax} - V_{LED_MIN} - V_{FB}) = 0.51W$$

This determines the package choice (θ_{JA}) in order to keep the junction temperature of the bipolar transistor below the maximum value allowed. At a maximum ambient temperature of +60°C the junction temperature becomes

$$T_J = T_A + P_{TOT} \times \theta_{JA} = 60 + 0.51 \times 125 = +123.75^\circ C$$

N-Channel MOSFET as the Pass Element

Alternatively, an N-channel MOSFET may be used in the same configuration. The current in R_B is then reduced compared to the case in which the bipolar transistor is used. For LED currents up to about 400mA a suitable MOSFET is DMN6068SE in the SOT223 package. The design procedure is as follows, referring to Figure 7.

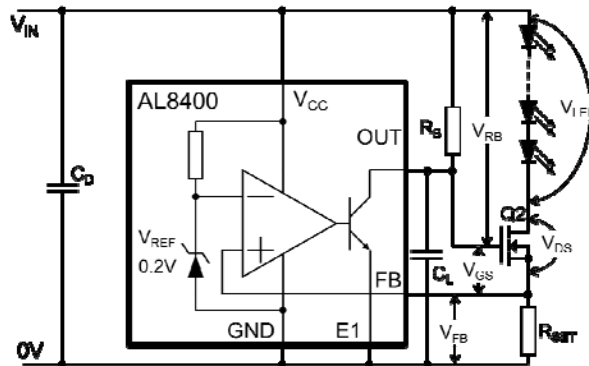

Figure 7 Application Circuit Using MOSFET

Application Information (cont.)

N-Channel MOSFET as the Pass Element (cont.)

The equations (1 and 2) for the bipolar transistor are transformed into:

LED circuit path:

$$5. \quad V_{CC} = (V_{LED} + V_{DS} + V_{FB}) \quad \text{where } V_{FB} \text{ is approximately the internal reference voltage of } 200\text{mV}.$$

Control drive circuit path

$$6. \quad V_{CC} = (V_{RB} + V_{GS} + V_{FB})$$

The maximum total LED voltage plus the reference voltage determines the minimum supply voltage. Substituting into equation 5 yields:

$$V_{CCmin} = V_{LED} + V_{DSmin} + V_{FB}$$

The MOSFET DC gate current is negligible, so the bias resistor R_B has only to provide the minimum output current of the AL8400. So rearranging equation 6 yields the boundaries for allowable R_B values:

$$7. \quad R_{Bmin} = \frac{V_{CCmax} - V_{GSmin} - V_{FB}}{I_{OUTmax}} \qquad 8. \quad R_{Bmax} = \frac{V_{CCmin} - V_{GSmax} - V_{FB}}{I_{OUTmin}}$$

Where I_{OUTmax} is the AL8400 maximum output current

Where I_{OUTmin} is the AL8400 minimum output current

Once the value of R_B has been determined, somewhere between R_{Bmax} and R_{Bmin} – trying to get I_{OUT} close to 1mA for all variations, the value for compensation capacitor, C_L , should be calculated.

The MOSFET selection is also influenced by the maximum power dissipation

$$P_{TOT} = I_{LED} * (V_{CC} - V_{LED} - V_{FB}) = I_{LED} * V_{DS}$$

Since this determines the package choice (θ_{JA}) in order to keep the junction temperature below the maximum value allowed.

$$T_J = T_A + P_{TOT} * \theta_{JA}$$

where

$T_{J(MAX)}$ is the maximum operating junction temperature,

T_A is the ambient temperature,

θ_{JA} is the junction to ambient thermal resistance.

Low Supply Voltages and MOSFET as Pass Element

When driving a single LED at low supply voltages, a low threshold MOSFET or high gain NPN bipolar transistor should be used as the LED driving pass transistor.

This is because a standard threshold voltage MOSFET might not have enough Gate-Source voltage to ensure that it is sufficiently enhanced to regulate the LED current.

MOSFET Example Choosing R_B and C_L

The driver is required to control 3 series connected LEDs at 200mA \pm 10% from an 12V \pm 5% supply. Each LED has a forward voltage of 3V minimum and of 3.6V maximum.

Therefore the minimum supply voltage is 11.4V and the maximum LED chain voltage is 10.8V.

Rearranging equation 5 (page 9); the minimum voltage drop across the MOSFET is required to be:

$$\begin{aligned} I_{LED} \times R_{DS} &= V_{CCmin} - V_{LEDmax} - V_{FB} = \\ &= 11.4V - 10.8V - 0.2V = 0.4V \rightarrow R_{DS(ON)} \leq 2\Omega \end{aligned}$$

We will use the DMN6068SE N-channel MOSFET (Q2) with a maximum $R_{DS(ON)}$ of 100m Ω at $V_{GS} = 4.5V$.

Application Information (cont.)

MOSFET Example Choosing R_B and C_L (cont.)

R_{Bmax}

The minimum recommended I_{OUT} for AL8400 is 0.3mA.

The maximum V_{GS} is not stated explicitly, but from the datasheet graphs (Figures 8 and 9) it is expected to be approximately 3.8V at -50°C.

$$R_{Bmax} = \frac{V_{CCmin} - V_{GSmax} - V_{FB}}{I_{OUTmin}} = \frac{11.4V - 3.8V - 0.2V}{0.3mA} = 24.7k\Omega$$

To ensure that the output capability of the AL8400 is not exceeded at maximum V_{IN} and minimum V_{GS} these values should be substituted back into the R_B equation to determine the minimum allowable value for R_B.

R_{Bmin}

The maximum recommended I_{OUT} for the AL8400 is 15mA. The minimum V_{GS} is about 1V and assuming V_{CCmax} = 8.4V:

$$R_{Bmin} = \frac{V_{CCmax} - V_{GSmin} - V_{FB}}{I_{OUTmax}} = \frac{12.6V - 1V - 0.2V}{15mA} = 480\Omega$$

this is less than 12kΩ and so the AL8400 output current is within its ratings.

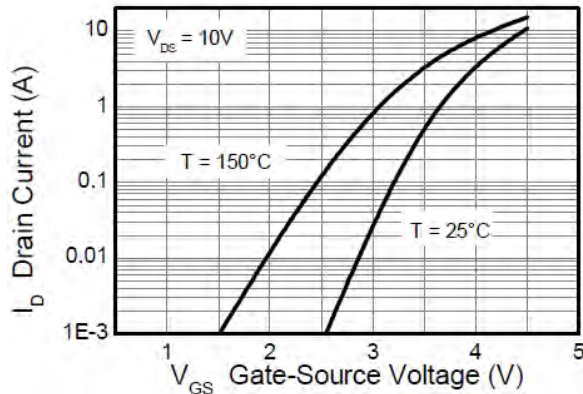

Figure 8 Typical Transfer Characteristics

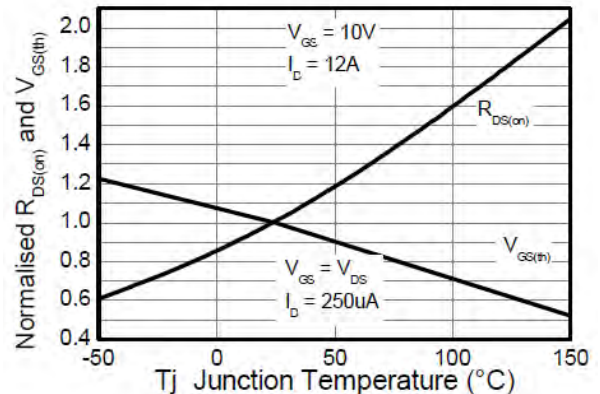

Figure 9 Normalised Curves and Temperature

Assuming V_{GS} ~ 3V and choosing an R_B = 8.2kΩ satisfies the requirements for the AL8400 conformance and sets approximately 1mA in the OUT pin. The required compensation capacitor can therefore be calculated from:

$$C_L \approx \frac{2ms}{8.2k\Omega} \approx 0.243\mu F \rightarrow 220nF$$

The value of R_{SET} is V_{REF}/I_{LED}

$$R_{SET} = 0.2/0.2 = 1\Omega$$

Finally, the maximum power dissipation of the external MOSFET is:

$$P_{TOT} = I_{LED} \times V_{DSMAX} = I_{LED} \times (V_{CCmax} - V_{LEDmin} - V_{FB}) = 0.2 \times (12.6 - 9 - 0.2) = 0.68W$$

This determines the package choice (θ_{JA}) in order to keep the junction temperature below the maximum value allowed.

$$T_J = T_A + P_{TOT} \times \theta_{JA} = 60 + 0.68 \times 62.5 = +102.5^\circ C$$

Application Information (cont.)

High Voltage Operation

The AL8400 also provides the capability to drive longer LED chains as the voltage across the LED chain is determined by the external switch. The lower supply voltage for the AL8400 can be derived from the supply to the LED chain either by putting a series resistor to the AL8400's V_{CC} pin and putting a suitable zener diode from its V_{CC} to GND Figure 10 or by tapping its V_{CC} from the LED chain Figure 11.

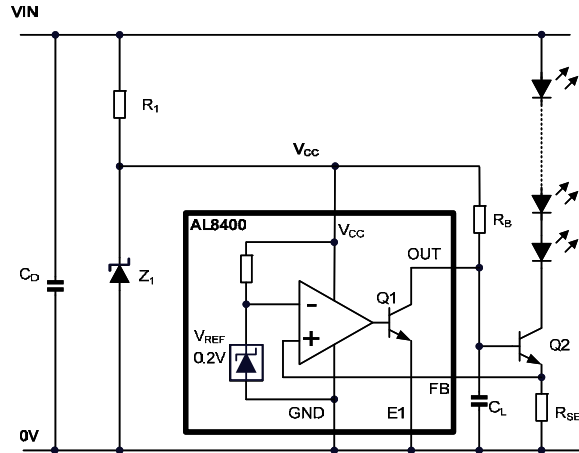

Figure 10 High Voltage Operation with Zener Diode from VIN

Equations 1 and 2 (from page 7) now transform into:

LED Circuit Path:

1. $V_{IN} = (V_{LED} + V_{CE} + V_{FB})$

Control Drive Circuit Path

2. $V_{CC} = (V_{RB} + V_{BE} + V_{FB})$

When the supply voltage for the AL8400 is derived using a zener diode, care has to be taken in dimensioning the resistor R1. The current taken through R1 from VIN has to be large enough to polarize the zener, bias the AL8400 supply current, AL8400 output current and the pass transistor across all input voltage variations.

An alternative way of operating the AL8400 from rails greater than 18V is to take its power supply from the LED chain itself.

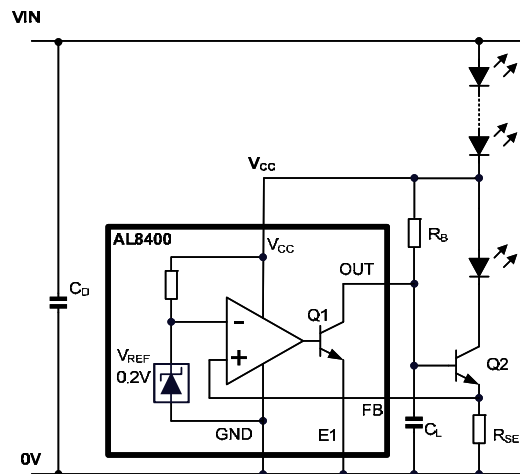
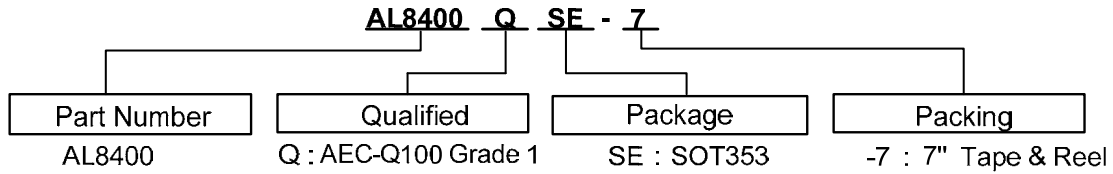

Figure 11 High Voltage Operation Tapping V_{CC} from the LED String

When the supply voltage for the AL8400 is derived from the LED string, care has to be taken in dimensioning the resistor R_b. The current spilled from the LED chain can reduce the accuracy of the system and brightness matching between the LED.

Ordering Information



Part Number	Package Code	Packaging	7" Tape and Reel		Automotive Grade
			Quantity	Part Number Suffix	
AL8400QSE-7	SE	SOT353	3000/Tape & Reel	-7	Y (Note 5)
AL8400SE-7	SE	SOT353	3000/Tape & Reel	-7	-

Note: 5. Qualified to AEC-Q100 Grade 1.

Marking Information

(1) SOT353

(Top View)

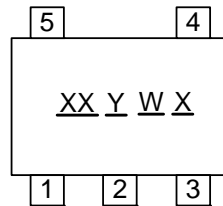

XX : Identification code
 Y : Year 0~9
 W : Week : A~Z : 1~26 week;
 a~z : 27~52 week; z represents
 52 and 53 week
 X : A~Z : Green

Part Number	Package	Identification Code
AL8400SE-7	SOT353	B4
AL8400QSE-7	SOT353	B4

Package Outline Dimensions (All dimensions in mm.)

Please see AP02002 at <http://www.diodes.com/datasheets/ap02002.pdf> for latest version.

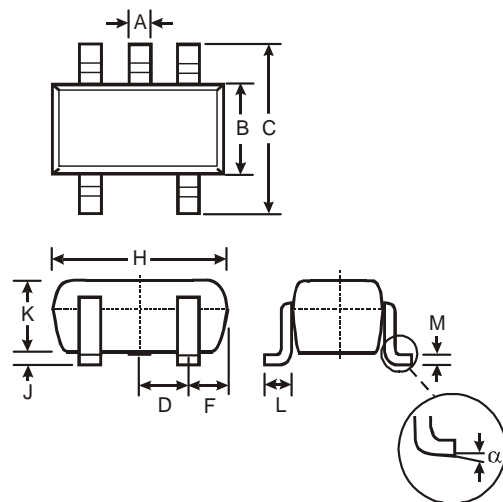

SOT353		
Dim	Min	Max
A	0.10	0.30
B	1.15	1.35
C	2.00	2.20
D	0.65 Typ	
F	0.40	0.45
H	1.80	2.20
J	0	0.10
K	0.90	1.00
L	0.25	0.40
M	0.10	0.22
α	0°	8°
All Dimensions in mm		

Suggested Pad Layout

Please see AP02001 at <http://www.diodes.com/datasheets/ap02001.pdf> for the latest version.

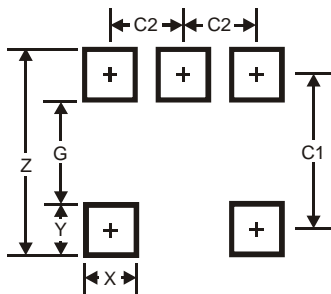

Dimensions	Value (in mm)
Z	2.5
G	1.3
X	0.42
Y	0.6
C1	1.9
C2	0.65

IMPORTANT NOTICE

DIODES INCORPORATED MAKES NO WARRANTY OF ANY KIND, EXPRESS OR IMPLIED, WITH REGARDS TO THIS DOCUMENT, INCLUDING, BUT NOT LIMITED TO, THE IMPLIED WARRANTIES OF MERCHANTABILITY AND FITNESS FOR A PARTICULAR PURPOSE (AND THEIR EQUIVALENTS UNDER THE LAWS OF ANY JURISDICTION).

Diodes Incorporated and its subsidiaries reserve the right to make modifications, enhancements, improvements, corrections or other changes without further notice to this document and any product described herein. Diodes Incorporated does not assume any liability arising out of the application or use of this document or any product described herein; neither does Diodes Incorporated convey any license under its patent or trademark rights, nor the rights of others. Any Customer or user of this document or products described herein in such applications shall assume all risks of such use and will agree to hold Diodes Incorporated and all the companies whose products are represented on Diodes Incorporated website, harmless against all damages.

Diodes Incorporated does not warrant or accept any liability whatsoever in respect of any products purchased through unauthorized sales channel. Should Customers purchase or use Diodes Incorporated products for any unintended or unauthorized application, Customers shall indemnify and hold Diodes Incorporated and its representatives harmless against all claims, damages, expenses, and attorney fees arising out of, directly or indirectly, any claim of personal injury or death associated with such unintended or unauthorized application.

Products described herein may be covered by one or more United States, international or foreign patents pending. Product names and markings noted herein may also be covered by one or more United States, international or foreign trademarks.

LIFE SUPPORT

Diodes Incorporated products are specifically not authorized for use as critical components in life support devices or systems without the express written approval of the Chief Executive Officer of Diodes Incorporated. As used herein:

- A. Life support devices or systems are devices or systems which:
 - 1. are intended to implant into the body, or
 - 2. support or sustain life and whose failure to perform when properly used in accordance with instructions for use provided in the labeling can be reasonably expected to result in significant injury to the user.
- B. A critical component is any component in a life support device or system whose failure to perform can be reasonably expected to cause the failure of the life support device or to affect its safety or effectiveness.



Customers represent that they have all necessary expertise in the safety and regulatory ramifications of their life support devices or systems, and acknowledge and agree that they are solely responsible for all legal, regulatory and safety-related requirements concerning their products and any use of Diodes Incorporated products in such safety-critical, life support devices or systems, notwithstanding any devices- or systems-related information or support that may be provided by Diodes Incorporated. Further, Customers must fully indemnify Diodes Incorporated and its representatives against any damages arising out of the use of Diodes Incorporated products in such safety-critical, life support devices or systems.

Copyright © 2012, Diodes Incorporated

www.diodes.com

Looking for pricing, stock, or lifecycle information?

Click below to explore more details on WIN SOURCE:

-  [View AL8400QSE-7 on WIN SOURCE](#)
-  [Diodes Incorporated Information](#)

Optimize Your Supply Chain with WIN SOURCE Solutions

-  Global Sourcing Solution
-  Obsolete Management
-  Cost Control Management
-  Shortage Management
-  Alternative Solution
-  Excess Inventory Management