

HIGH-SPEED CMOS LOGIC 16-CHANNEL ANALOG MULTIPLEXER and DEMULTIPLEXER

 Check for Samples: [CD74HCT4067-Q1](#)

1 FEATURES

- Qualified for Automotive Applications
- AEC-Q100 Test Guidance With the Following Results:
 - Device Temperature Grade 1: –40°C to 125°C Ambient Operating Temperature Range
 - Device HBM ESD Classification Level H1A
 - Device CDM ESD Classification Level C2
- Wide Analog Input Voltage Range
- Low ON Resistance
 - 70 Ω Typical ($V_{CC} = 4.5\text{ V}$)
- Fast Switching and Propagation Speeds
- Break-Before-Make Switching
 - 6 ns Typical ($V_{CC} = 4.5\text{ V}$)
- Fanout (Over Temperature Range)
 - Standard Outputs: 10 LSTTL Loads
 - Bus Driver Outputs: 15 LSTTL Loads
- Balanced Propagation Delay and Transition Times
- Significant Power Reduction Compared to LSTTL Logic ICs
- 4.5-V to 5.5-V Operation
- Direct LSTTL Input Logic Compatibility: $V_{IL} = 0.8$

 $V_{Max}, V_{IH} = 2\text{ V Min}$

- CMOS Input Compatibility: $I_I \leq 1\text{ }\mu\text{A}$ at V_{OL}, V_{OH}

2 APPLICATIONS

- Automotive
- Analog Switch
- Analog Multiplexer and Demultiplexer

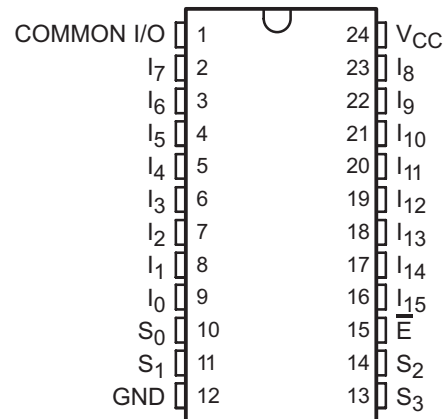
**M PACKAGE
(TOP VIEW)**

3 DESCRIPTION

The CD74HCT4067-Q1 device is a digitally controlled analog switch that utilizes silicon-gate CMOS technology to achieve operating speeds similar to LSTTL, with the low power consumption of standard CMOS integrated circuits.

This analog multiplexer and demultiplexer controls analog voltages that may vary across the voltage supply range. It is a bidirectional switch, thus allowing any analog input to be used as an output and vice-versa. The switch has low (on) resistance and low (off) leakages. In addition, the device has an enable control that, when high, disables all switches to their off state.

ORDERING INFORMATION⁽¹⁾

T_A	PACKAGE ⁽²⁾	ORDERABLE PART NUMBER ⁽³⁾	TOP-SIDE MARKING
–40°C to 125°C	DW-SOIC-M Reel of 2000	CD74HCT4067QM96Q1	HCT4067I

(1) For the most current package and ordering information, see the Package Option Addendum at the end of this document, or see the TI web site at www.ti.com.

(2) Package drawings, thermal data, and symbolization are available at www.ti.com/packaging.

(3) The suffix 96 denotes tape and reel.

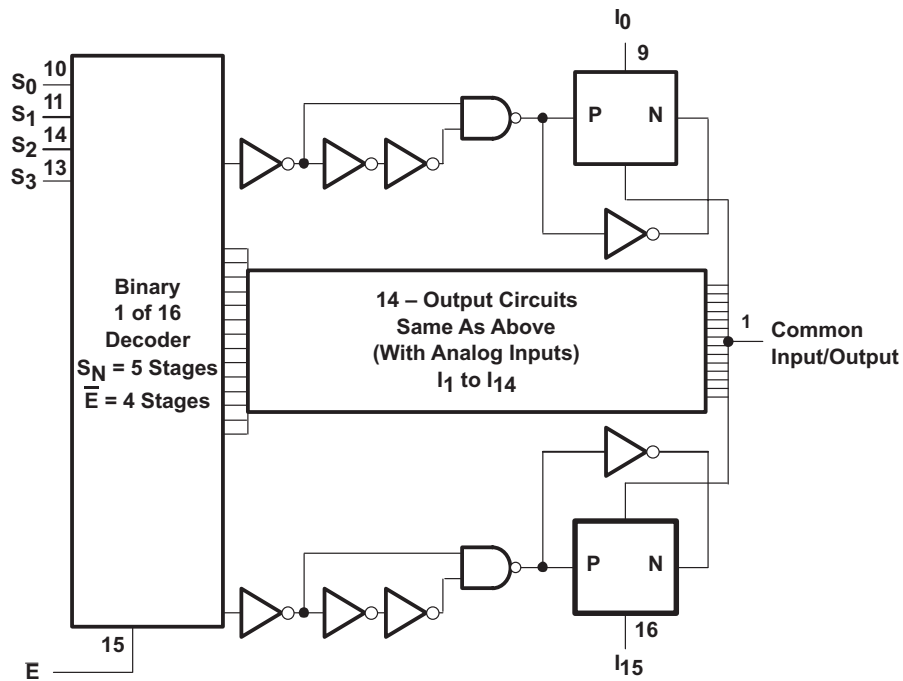

Table 1. FUNCTION TABLE⁽¹⁾

S0	S1	S2	S3	\bar{E}	SELECTED CHANNEL
X	X	X	X	H	None
L	L	L	L	L	0
H	L	L	L	L	1
L	H	L	L	L	2
H	H	L	L	L	3
L	L	H	L	L	4
H	L	H	L	L	5
L	H	H	L	L	6
H	H	H	L	L	7
L	L	L	H	L	8
H	L	L	H	L	9
L	H	L	H	L	10
H	H	L	H	L	11
L	L	H	H	L	12
H	L	H	H	L	13
L	H	H	H	L	14
H	H	H	H	L	15

(1) H = High level
 L = Low level
 X = Don't care

Logic Diagram (Positive Logic)



3.1 ABSOLUTE MAXIMUM RATINGS⁽¹⁾

over operating free-air temperature range (unless otherwise noted)

		VALUE		UNIT
		MIN	MAX	
V_{CC}	Supply voltage range ⁽²⁾	-0.5	7	V
I_{IK}	Input clamp current ($V_I < -0.5$ V or $V_I > V_{CC} + 0.5$ V)		±20	mA
I_{OK}	Output clamp current ($V_O < -0.5$ V or $V_O > V_{CC} + 0.5$ V)		±20	mA
I_O	Switch current ($V_O > -0.5$ V or $V_O < V_{CC} + 0.5$ V)		±25	mA
I_O	Output source or sink current per output pin ($V_O > -0.5$ V or $V_O < V_{CC} + 0.5$ V)		±25	mA
	Continuous current through V_{CC} or GND		±50	mA
T_J	Maximum junction temperature		150	°C
T_{stg}	Storage temperature range	-65	150	°C
ESD Rating	Human Body Model (HBM) AEC-Q100 classification level H1A		400	V
	Charged Device Model (CDM) AEC-Q100 classification level C2		250	V
	Latch-up per JESD78D	Class 1		

- (1) Stresses beyond those listed under *Absolute Maximum Ratings* may cause permanent damage to the device. These are stress ratings only, and functional operation of the device at these or any other conditions beyond those indicated under *Recommended Operating Conditions* is not implied. Exposure to absolute-maximum-rated conditions for extended periods may affect device reliability.
- (2) All voltages are referenced to GND, unless otherwise specified.

3.2 THERMAL INFORMATION

THERMAL METRIC ⁽¹⁾		CD74HCT4067-Q1	UNIT
		DW (24 PINS)	
θ_{JA}	Junction-to-ambient thermal resistance	62.3	°C/W
θ_{Jctop}	Junction-to-case (top) thermal resistance	30.5	
θ_{JB}	Junction-to-board thermal resistance	31.8	
ψ_{JT}	Junction-to-top characterization parameter	7.7	
ψ_{JB}	Junction-to-board characterization parameter	31.5	
θ_{Jcbot}	Junction-to-case (bottom) thermal resistance	N/A	

- (1) For more information about traditional and new thermal metrics, see the *Semiconductor and IC Package Thermal Metrics* application report (SPRA953).

3.3 RECOMMENDED OPERATING CONDITIONS⁽¹⁾

over operating free-air temperature range (unless otherwise noted)

		MIN	MAX	UNIT
V_{CC}	Supply voltage	4.5	5.5	V
V_{IH}	High-level input voltage	2		V
V_{IL}	Low-level input voltage		0.8	V
V_I	Input voltage	0	V_{CC}	V
V_O	Output voltage	0	V_{CC}	V
t_t	Input transition (rise and fall) time	$V_{CC} = 4.5$ V	500	ns
T_A	Operating free-air temperature	-40	125	°C

- (1) All unused inputs of the device must be held at V_{CC} or GND to ensure proper device operation. Refer to the TI application report, *Implications of Slow or Floating CMOS Inputs*, literature number SCBA004.

3.4 ELECTRICAL CHARACTERISTICS

over operating free-air temperature range (unless otherwise noted)

PARAMETER	TEST CONDITIONS	V _I	V _{CC}	T _A = 25°C			T _A = -40°C to 125°C		UNIT
				MIN	TYP	MAX	MIN	MAX	
I _I	Logic input	V _{CC} or GND	5.5 V			±0.1		±1	μA
I _{Iz}	V _{IS} = V _{CC} or GND, \bar{E} = V _{CC}		5.5 V			±0.8		±8	μA
r _{on}	I _O = 1 mA	V _{IS} = V _{CC} or GND	V _{CC} or GND	4.5 V	70	160		200	Ω
		V _{IS} = V _{CC} to GND	V _{CC} to GND	4.5 V	90	180		225	
Δr _{on}	Between any two switches		4.5 V		10				Ω
I _{CC}		V _{CC} or GND	5.5 V			8		80	μA
ΔI _{CC}	Per input pin: 1 unit load ⁽¹⁾	V _{CC} - 2.1 V	4.5 V to 5.5 V		100	360		450	μA
C _I	Control inputs					10		10	pF

(1) For dual-supply systems, theoretical worst-case (V_I = 2.4 V, V_{CC} = 5.5 V) specification is 1.8 mA.

3.5 HCT INPUT LOADING

INPUT	UNIT LOADS ⁽¹⁾
S ₀ – S ₃	0.5
\bar{E}	0.3

(1) Unit load is ΔI_{CC} limit specified in the electrical characteristics table, for example, 360 μA max at 25°C.

3.6 SWITCHING CHARACTERISTICS

over operating free-air temperature range (unless otherwise noted) see [Figure 5](#)

PARAMETER	FROM (INPUT)	TO (OUTPUT)	LOAD CAPACITANCE	V _{CC}	T _A = 25°C			T _A = -40°C TO 125°C		UNIT
					MIN	TYP	MAX	MIN	MAX	
t _{pd}	I _n	Common I/O	C _L = 15 pF	5 V		6			ns	
			C _L = 50 pF	4.5 V		15		19		
t _{en}	\bar{E}	Common I/O	C _L = 15 pF	5 V		25			ns	
			C _L = 50 pF	4.5 V		60		75		
t _{en}	S _n	Common I/O	C _L = 15 pF	5 V		25			ns	
			C _L = 50 pF	4.5 V		60		75		
t _{dis}	\bar{E}	Common I/O	C _L = 15 pF	5 V		23			ns	
			C _L = 50 pF	4.5 V		55		69		
t _{dis}	S _n	Common I/O	C _L = 15 pF	5 V		21			ns	
			C _L = 50 pF	4.5 V		58		73		

3.7 OPERATING CHARACTERISTICS

V_{CC} = 5 V, T_A = 25°C, input t_r, t_f = 6 ns

PARAMETER	TEST CONDITIONS	MIN	TYP	MAX	UNIT
C _{pd}	Power dissipation capacitance ⁽¹⁾		96		pF

(1) C_{pd} is used to determine the dynamic power consumption (P_D), per package.

$$P_D = (C_{pd} \times V_{CC}^2 \times f_i) + \sum (C_L + C_S) \times V_{CC}^2 \times f_o$$

f_O = output frequency

f_I = input frequency

C_L = output load capacitance

C_S = switch capacitance

V_{CC} = supply voltage

3.8 ANALOG CHANNEL CHARACTERISTICS

T_A = 25°C

PARAMETER	TEST CONDITIONS	V _{CC}	TYP	UNIT
f _{max}	Switch frequency response bandwidth at -3 dB	4.5 V	89	MHz
	Sine-wave distortion	4.5 V	0.051	%
	Switch OFF signal feedthrough	4.5 V	-75	dB
C _S	Switch input capacitance		5	pF
C _{COM}	Common capacitance		50	pF

- (1) Adjust input voltage to obtain 0 dBm at output, f = 1 MHz.
- (2) V_{IS} is centered at V_{CC} / 2

4 PARAMETER MEASUREMENT INFORMATION

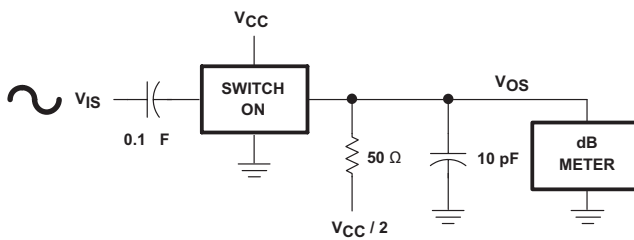

Figure 1. Frequency-Response Test Circuit

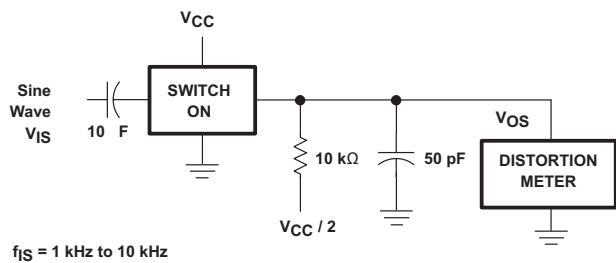

Figure 2. Sine-Wave Distortion Test Circuit

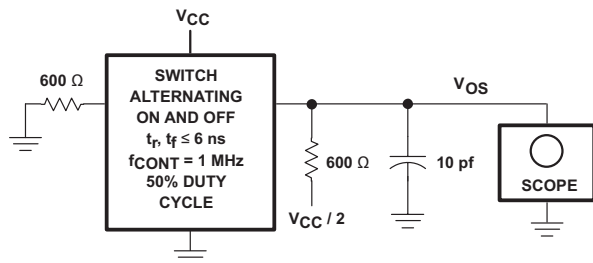

Figure 3. Control-to-Switch Feedthrough Noise Test Circuit

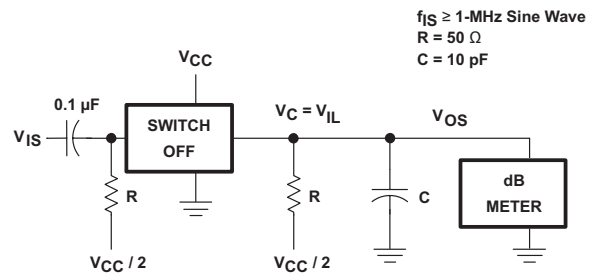
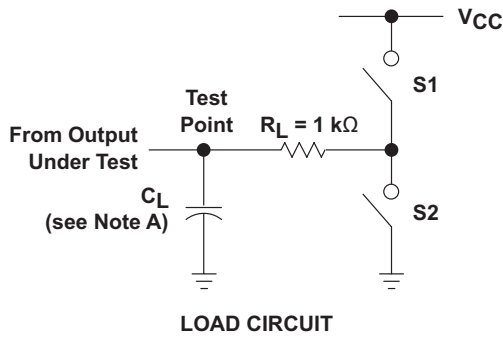
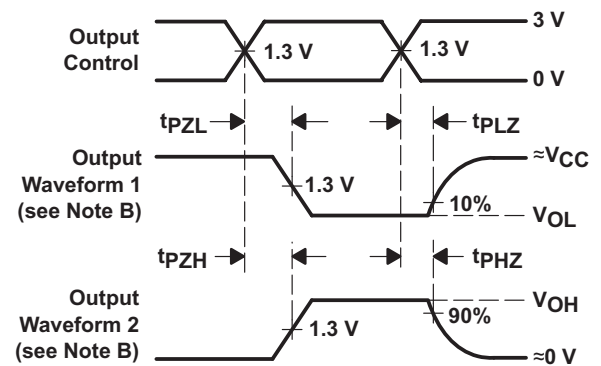
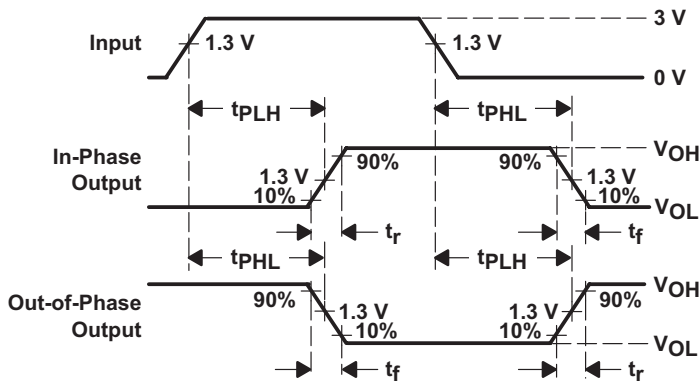

Figure 4. Switch OFF Signal Feedthrough Test Circuit

PARAMETER MEASUREMENT INFORMATION (continued)



PARAMETER	S1	S2	
t_{en}	tpZH	Open	Closed
	tpZL	Closed	Open
t_{dis}	tpHZ	Open	Closed
	tpLZ	Closed	Open
t_{pd}	Open	Open	



- NOTES:
- A. C_L includes probe and test-fixture capacitance.
 - B. Waveform 1 is for an output with internal conditions such that the output is low, except when disabled by the output control. Waveform 2 is for an output with internal conditions such that the output is high, except when disabled by the output control.
 - C. Phase relationships between waveforms were chosen arbitrarily. All input pulses are supplied by generators having the following characteristics: $PRR \leq 1 \text{ MHz}$, $Z_O = 50 \Omega$, $t_r = 6 \text{ ns}$, $t_f = 6 \text{ ns}$.
 - D. For clock inputs, f_{max} is measured with the input duty cycle at 50%.
 - E. The outputs are measured one at a time, with one input transition per measurement.
 - F. t_{pLZ} and t_{pHZ} are the same as t_{dis} .
 - G. t_{pZL} and t_{pZH} are the same as t_{en} .
 - H. t_{pLH} and t_{pHL} are the same as t_{pd} .

Figure 5. Load Circuit and Voltage Waveforms

5 TYPICAL CHARACTERISTICS

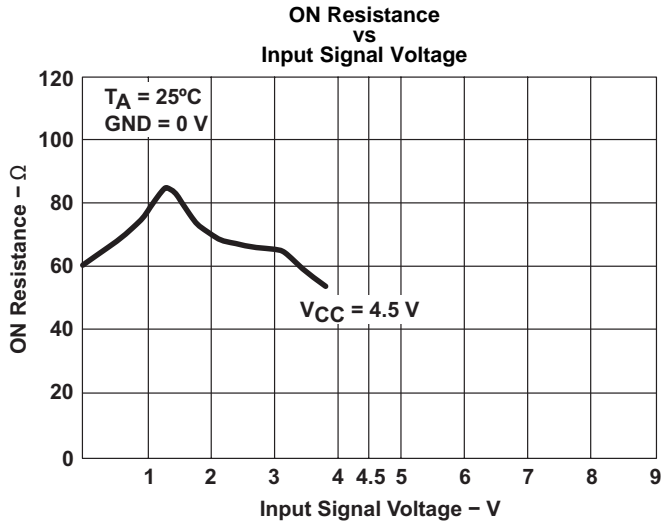

Figure 6.

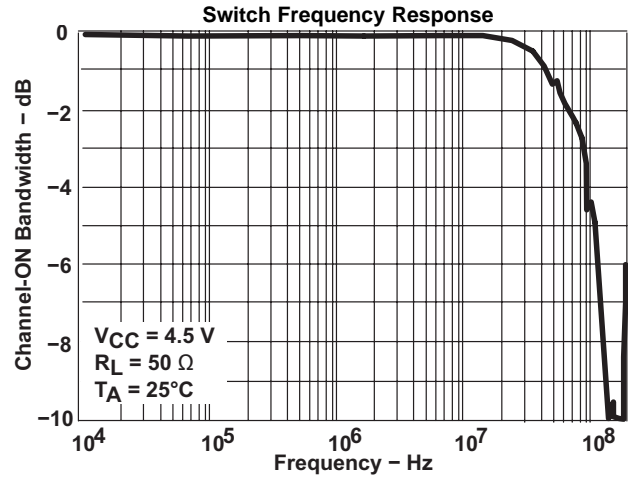

Figure 7.

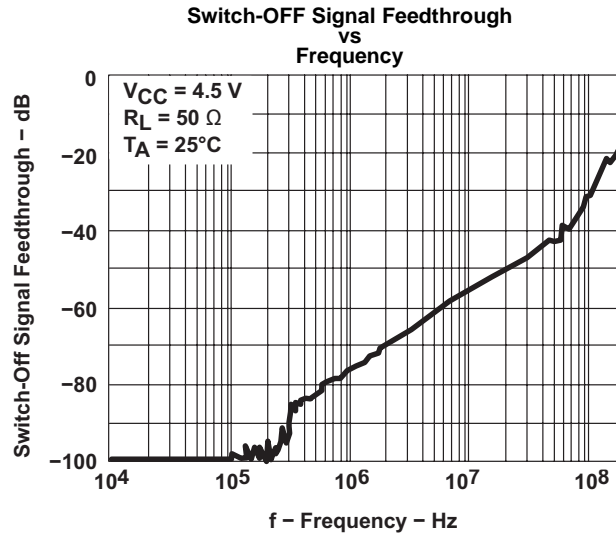

Figure 8.

6 REVISION HISTORY

NOTE: Page numbers for previous revisions may differ from page numbers in the current version.

Changes from Revision A (April, 2008) to Revision B	Page
• Changed H2 to H1A and C3B to C2 throughout document	1
• Added AEC-Q100 info to Features.....	1
• Removed from Features: Wide Operating Temperature Range: –40°C to 85°C	1
• Added applications	1
• Replaced SOIC-M package info in ordering info table with new row for DW-SOIC-M package	1
• Added ESD ratings to Abs Max table	3
• Added latch-up row in Abs Max table	3
• Changed max T_A value from 85°C to 125°C	3
• Changed $T_A = -40^\circ\text{C}$ to 85°C column to $T_A = -40^\circ\text{C}$ to 125°C	4
• Changed $T_A = -40^\circ\text{C}$ to 85°C column to $T_A = -40^\circ\text{C}$ to 125°C	4

PACKAGING INFORMATION

Orderable Device	Status (1)	Package Type	Package Drawing	Pins	Package Qty	Eco Plan (2)	Lead finish/ Ball material (6)	MSL Peak Temp (3)	Op Temp (°C)	Device Marking (4/5)	Samples
CD74HCT4067QM96Q1	ACTIVE	SOIC	DW	24	2000	RoHS & Green	NIPDAU	Level-1-260C-UNLIM	-40 to 125	HCT4067I	Samples

(1) The marketing status values are defined as follows:

ACTIVE: Product device recommended for new designs.

LIFEBUY: TI has announced that the device will be discontinued, and a lifetime-buy period is in effect.

NRND: Not recommended for new designs. Device is in production to support existing customers, but TI does not recommend using this part in a new design.

PREVIEW: Device has been announced but is not in production. Samples may or may not be available.

OBSOLETE: TI has discontinued the production of the device.

(2) **RoHS:** TI defines "RoHS" to mean semiconductor products that are compliant with the current EU RoHS requirements for all 10 RoHS substances, including the requirement that RoHS substance do not exceed 0.1% by weight in homogeneous materials. Where designed to be soldered at high temperatures, "RoHS" products are suitable for use in specified lead-free processes. TI may reference these types of products as "Pb-Free".

RoHS Exempt: TI defines "RoHS Exempt" to mean products that contain lead but are compliant with EU RoHS pursuant to a specific EU RoHS exemption.

Green: TI defines "Green" to mean the content of Chlorine (Cl) and Bromine (Br) based flame retardants meet JS709B low halogen requirements of <=1000ppm threshold. Antimony trioxide based flame retardants must also meet the <=1000ppm threshold requirement.

(3) MSL, Peak Temp. - The Moisture Sensitivity Level rating according to the JEDEC industry standard classifications, and peak solder temperature.

(4) There may be additional marking, which relates to the logo, the lot trace code information, or the environmental category on the device.

(5) Multiple Device Markings will be inside parentheses. Only one Device Marking contained in parentheses and separated by a "~" will appear on a device. If a line is indented then it is a continuation of the previous line and the two combined represent the entire Device Marking for that device.

(6) Lead finish/Ball material - Orderable Devices may have multiple material finish options. Finish options are separated by a vertical ruled line. Lead finish/Ball material values may wrap to two lines if the finish value exceeds the maximum column width.

Important Information and Disclaimer:The information provided on this page represents TI's knowledge and belief as of the date that it is provided. TI bases its knowledge and belief on information provided by third parties, and makes no representation or warranty as to the accuracy of such information. Efforts are underway to better integrate information from third parties. TI has taken and continues to take reasonable steps to provide representative and accurate information but may not have conducted destructive testing or chemical analysis on incoming materials and chemicals. TI and TI suppliers consider certain information to be proprietary, and thus CAS numbers and other limited information may not be available for release.

In no event shall TI's liability arising out of such information exceed the total purchase price of the TI part(s) at issue in this document sold by TI to Customer on an annual basis.

OTHER QUALIFIED VERSIONS OF CD74HCT4067-Q1 :

- Catalog : [CD74HCT4067](#)

NOTE: Qualified Version Definitions:

- Catalog - TI's standard catalog product

TAPE AND REEL INFORMATION

QUADRANT ASSIGNMENTS FOR PIN 1 ORIENTATION IN TAPE

*All dimensions are nominal

Device	Package Type	Package Drawing	Pins	SPQ	Reel Diameter (mm)	Reel Width W1 (mm)	A0 (mm)	B0 (mm)	K0 (mm)	P1 (mm)	W (mm)	Pin1 Quadrant
CD74HCT4067QM96Q1	SOIC	DW	24	2000	330.0	24.4	10.75	15.7	2.7	12.0	24.0	Q1

TAPE AND REEL BOX DIMENSIONS

*All dimensions are nominal

Device	Package Type	Package Drawing	Pins	SPQ	Length (mm)	Width (mm)	Height (mm)
CD74HCT4067QM96Q1	SOIC	DW	24	2000	350.0	350.0	43.0

DW (R-PDSO-G24)

PLASTIC SMALL OUTLINE



- NOTES:
- All linear dimensions are in inches (millimeters). Dimensioning and tolerancing per ASME Y14.5M-1994.
 - This drawing is subject to change without notice.
 - Body dimensions do not include mold flash or protrusion not to exceed 0.006 (0,15).
 - Falls within JEDEC MS-013 variation AD.

IMPORTANT NOTICE AND DISCLAIMER

TI PROVIDES TECHNICAL AND RELIABILITY DATA (INCLUDING DATA SHEETS), DESIGN RESOURCES (INCLUDING REFERENCE DESIGNS), APPLICATION OR OTHER DESIGN ADVICE, WEB TOOLS, SAFETY INFORMATION, AND OTHER RESOURCES "AS IS" AND WITH ALL FAULTS, AND DISCLAIMS ALL WARRANTIES, EXPRESS AND IMPLIED, INCLUDING WITHOUT LIMITATION ANY IMPLIED WARRANTIES OF MERCHANTABILITY, FITNESS FOR A PARTICULAR PURPOSE OR NON-INFRINGEMENT OF THIRD PARTY INTELLECTUAL PROPERTY RIGHTS.

These resources are intended for skilled developers designing with TI products. You are solely responsible for (1) selecting the appropriate TI products for your application, (2) designing, validating and testing your application, and (3) ensuring your application meets applicable standards, and any other safety, security, regulatory or other requirements.

These resources are subject to change without notice. TI grants you permission to use these resources only for development of an application that uses the TI products described in the resource. Other reproduction and display of these resources is prohibited. No license is granted to any other TI intellectual property right or to any third party intellectual property right. TI disclaims responsibility for, and you will fully indemnify TI and its representatives against, any claims, damages, costs, losses, and liabilities arising out of your use of these resources.

TI's products are provided subject to [TI's Terms of Sale](#) or other applicable terms available either on [ti.com](https://www.ti.com) or provided in conjunction with such TI products. TI's provision of these resources does not expand or otherwise alter TI's applicable warranties or warranty disclaimers for TI products.

TI objects to and rejects any additional or different terms you may have proposed.

Mailing Address: Texas Instruments, Post Office Box 655303, Dallas, Texas 75265
Copyright © 2024, Texas Instruments Incorporated

Looking for pricing, stock, or lifecycle information?

Click below to explore more details on WIN SOURCE:

 [View ADS8168IRHBR](#) on WIN SOURCE

 [Texas Instruments](#) Information

Optimize Your Supply Chain with WIN SOURCE Solutions

-  Global Sourcing Solution
-  Obsolete Management
-  Cost Control Management
-  Shortage Management
-  Alternative Solution
-  Excess Inventory Management