



THE DATASHEET OF ADS4125EVM



Thomas Neu

Table of Contents

1 Overview	2
1.1 Purpose.....	2
1.2 EVM Quick-Start Procedure.....	2
2 Circuit Description	4
2.1 Schematic Diagram.....	4
2.2 Circuit Function.....	4
3 TI ADC SPI Control Interface	12
3.1 Installing the ADC SPI Interface.....	12
3.2 Setting Up the EVM for ADC SPI Control.....	12
3.3 Using the TI ADC SPI Interface Software.....	13
4 Quick Start Setup	15
5 Evaluation	16
5.1 Register Programming.....	16
5.2 Quick-Test Results.....	17

List of Figures

Figure 2-1. ADS41xx Jumpers.....	4
Figure 2-2. ADS41xx/58B18 Surface Jumpers.....	5
Figure 2-3. ADS41xx/58B18EVM Power Distribution.....	6
Figure 2-4. CDCE72010 EEPROM Configuration Block Diagram.....	9
Figure 3-1. Found New Hardware.....	12
Figure 3-2. GUI Main Page.....	13
Figure 3-3. GUI Advanced Page.....	14
Figure 5-1. TSW1400 GUI Introduction.....	16
Figure 5-2. Quick-Setup Test Result.....	17

List of Tables

Table 1-1. Jumper List.....	2
Table 2-1. EVM Power Supply Jumper Description.....	6
Table 2-2. EVM Power Supply Options.....	7
Table 2-3. Clock Input Jumper Description.....	8
Table 2-4. EVM Clock Input Options.....	8
Table 2-5. Analog Input Jumper Description.....	10
Table 2-6. EVM Analog Input Options.....	10

Trademarks

Mini-Circuits™ is a trademark of Scientific Components Corporation.
Windows™ is a trademark of Microsoft Corporation.
All trademarks are the property of their respective owners.

1 Overview

This evaluation module (EVM) user's guides give an overview of the EVM and provides a general description of the features and functions to be considered while using this module.

This EVM user's guide applies to multiple EVMs:

- ADS41xx family:
 - ADS4126, ADS4146, ADS4128, ADS4129, ADS4149, ADS41B29, ADS41B49, ADS58B18

1.1 Purpose

The ADS41xx/58B18 EVM provides a platform for evaluating the analog-to-digital converter (ADC) under various signal, clock, reference, and power supply conditions. Use this document in combination with the EVM schematic diagram supplied.

1.2 EVM Quick-Start Procedure

The ADS41xx/58B18EVM provides numerous options for providing clock, input frequency, and power to the ADC under evaluation. The quick-start procedure describes how to quickly get initial results using the default configuration of the EVM as it was shipped. The EVM can be put back to default configuration by setting all jumpers with the default values as described in [Table 1-1](#). The default configuration of the EVM is for single-ended signals into the analog input and clock input. These signals are converted from single-ended to differential on-board with the use of transformers. The default configuration for the power supply is to provide a single 3.3-V supply to the red banana jack J16, PWR_IN. The default configuration for the EVM is to control the modes of operation by jumper settings for parallel input control pins rather than serial SPI control of the register space. The other modes of operation of the EVM are described in the latter sections of this document.

CAUTION

Voltage Limits: Exceeding the maximum input voltages can damage EVM components.
Undervoltage can cause improper operation of some or all of the EVM components.

A quick-setup procedure for the default configuration of the ADS41xx/58B18EVM follows:

1. Verify all jumper settings against the schematic jumper list in [Table 1-1](#).

Table 1-1. Jumper List

Jumper	Function	Default Jumper Setting
Interface Circuit Operational Amplifier THS4509 (Bypassed)		
R94/95/98/106	AMP+	R94/98
R82/96/97/99	AMP-	R97
JP7	PD	1-2
ADC Circuit		
JP12	Parallel	1-2
JP11	SDA	Open
JP9	SEN	1-2
JP15	OE	Open
J2	DFS	7-8
J1	SEN	7-8
Clock Interface Circuit CDCE72010 (Bypassed)		
R81/107	CLOCK IN	R81
R113/114/115	CLOCK IN, Y0, Y1P SELECT	R115
R108/110	Y1N SELECT	R110
JP1	PWRDWN CDC	1-2

Table 1-1. Jumper List (continued)

Jumper	Function	Default Jumper Setting
Power Supply		
JP13	1.8VA_IN	1-2
JP14	1.8VD_IN	1-2
JP3	3.3V CDC	1-2
JP17	3.3V input select for LDO or switching regulator	1-2
JP19	1.8V output select from LDO or switching regulator	1-2

2. Connect the 3.3-V supply between J16 and J12 (GND). Do not connect a voltage source greater than 3.6 V.
3. Switch on external 3.3-V power supply.
4. Using a function generator with 50- Ω output impedance, generate a 0-V offset, 1.5-V_{pp} sine-wave clock into J19. The frequency of the clock must be within the specification for the device speed grade.
5. Use a frequency generator with a 50- Ω output impedance to provide a 0-V offset, -1-dBFS-amplitude sine-wave signal into J6. This provides a transformer-coupled differential input signal to the ADC.
6. Connect the TSW1400 or suitable logic analyzer to J10 to capture the resulting digital data. If a TSW1400 is being used to capture data, follow the additional alphabetically labeled steps. For more information, see [Section 5](#).
 - a. After installing HSDC Pro and connecting the TSW1400 to the USB port, open HSDC Pro.
 - b. In HSDC Pro, when the *Select Board* window appears, select the interface board being used and click OK.
 - c. In the *Select a Device* window, select ADC in the drop-down menu.
 - d. In the main window, under *Select ADC*, use the drop-down menu to select the device under test.
 - e. Under Test Selection, select Single Tone to run a single tone FFT test.
 - f. Change the ADC Output Data Rate and ADC Input Target Frequency to match those of the signal generator.
 - g. Press the Capture button to begin capturing data.

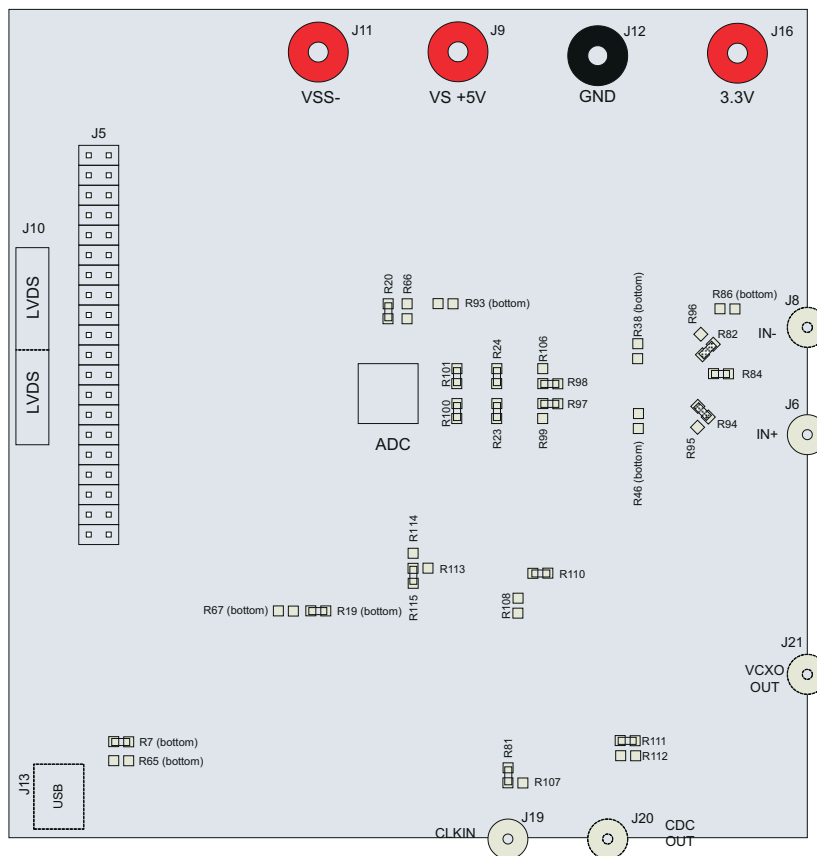

Figure 2-2. ADS41xx/58B18 Surface Jumpers

The following sections describe the function of individual circuits. See the relevant data sheet for device operating characteristics.

2.2.1 Power

Power is supplied to the EVM through banana jacks; from this input power, three different ways are available of delivering power to the ADC and the other EVM functions. Figure 2-3 shows a simplified representation of the power options available for the ADS41xx/58B18EVM. The default option is to provide 3.3 V to the red banana jack J16, and from there the EVM generates 1.8 V for the analog and digital supplies to the ADC. The 1.8-V rails for the ADC can be generated from the 3.3-V input either through a low-noise dropout regulator (TPS79618), from a switching regulator (TPS62562) for maximum power efficiency or from an external 1.8-V power supply. The EVM also generates the proper voltages for optional features of the EVM such as the Clock Generation circuitry, the USB circuitry, and the CMOS output buffer.

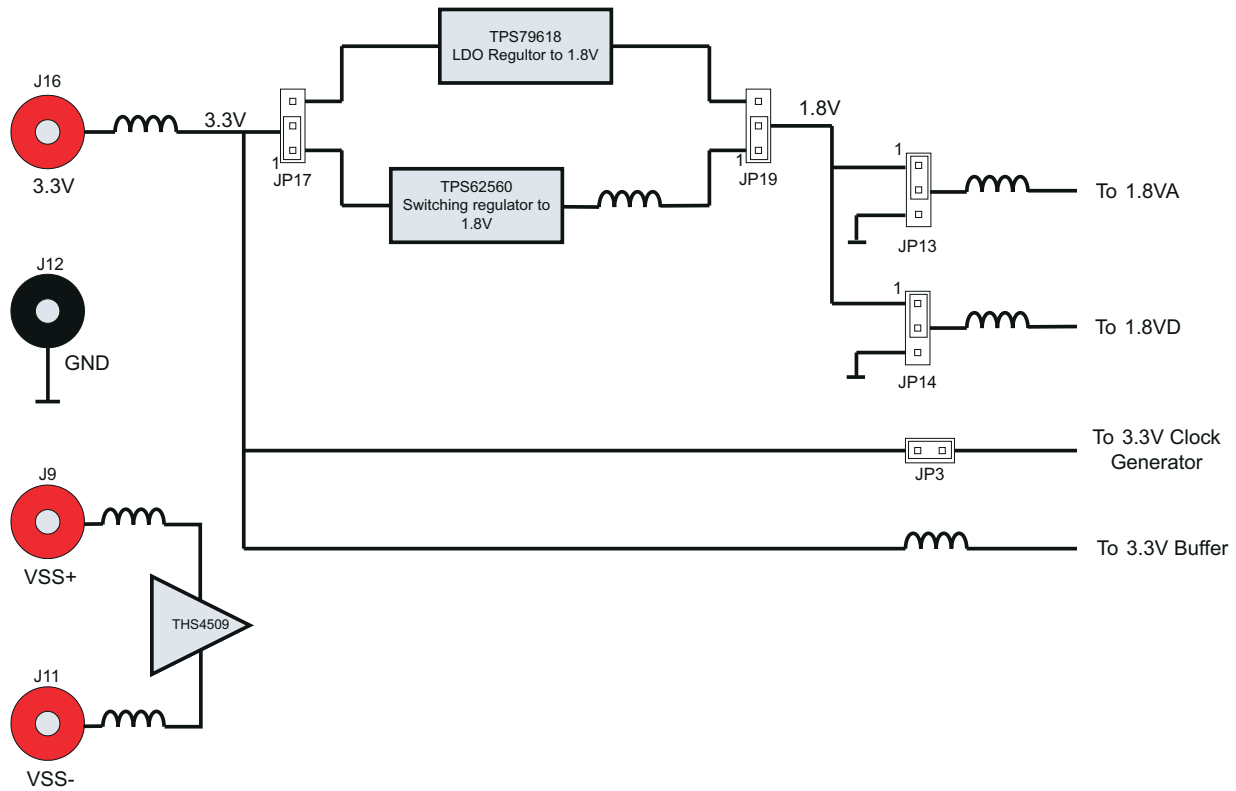

Figure 2-3. ADS41xx/58B18EVM Power Distribution

Some ADC devices that may be evaluated on the ADS41xx/58B18 platform require a 3.3-V supply for an internal front-end buffer. For this reason, an isolated 3.3V_BUF supply is on the power section of the schematic.

Power for the optional THS4509 operational amplifier is supplied by banana jacks J9 and J11. If the amplifier is being evaluated, 5 V is supplied to J9 and J11 is connected to ground. Otherwise, these inputs may be left unconnected.

The power supply for the default operation of the ADS41xx/58B18EVM has been simplified by requiring only a single 3.3 V. [Table 2-1](#) displays the general jumper setting information; [Table 2-2](#) displays the various power option settings. Prior to making any jumper settings, see the schematic located on the TI Web site in the relevant ADS41xx or ADS41Bxx product folder.

Table 2-1. EVM Power Supply Jumper Description

EVM Banana Jack/ Jumper	Description	Jumper setting
J16	Input	3.3-V power supply input
JP3	3.3 V for CDCE72010	Shunt for CDCE72010 operation
JP13	1.8-VA input	1-2 → 1.8 V from LDO/switching regular to 1.8 VA of ADC (default); 2-3 → option for external 1.8-V supply
JP14	1.8-VD input	1-2 → 1.8 V from LDO/switching regular to 1.8 VD of ADC (default); 2-3 → option for external 1.8-V supply
JP17	3.3-V input selection for LDO/switching regulator	1-2 → 3.3-V input for TPS62562 (default); 2-3 → 3.3-V input for TPS79618
JP19	1.8-V selection from LDO/switching regulator	1-2 → 1.8-V output from TPS62562 (default); 2-3 → 1.8-V output from TPS79618

Table 2-2. EVM Power Supply Options

EVM Option	Evaluation Goal	Jumper Changes Required	Voltage on J16	Comments
1	Evaluate ADC performance using a switching power supply (TP62562)	JP13 → 1-2; JP14 → 1-2; JP17 → 1-2; JP19 → 1-2;	3.3 V	Maximum performance and efficiency.
2	Evaluate ADC performance using a LDO-based (TPS79618) solution.	JP13 → 1-2; JP14 → 1-2; JP17 → 2-3; JP19 → 2-3;	3.3 V	Maximum performance.
3	Evaluate ADC performance using an isolated ADC AVDD and DVDD for current consumption measurements	JP13 → 1.8V on 2-3; JP14 → 1.8V on 2-3; JP17 → open3; JP19 → open;	3.3 V	Isolated power supply for current consumption measurements

2.2.1.1 Power Supply Option 1

The 1.8-V rails for the ADC are generated by the TPS62562 switching regulator. The TPS62562 is a step-down (buck) converter with an acceptable input range of up to 5.5 V. However, because other circuits on the EVM are connected to the 3.3-V input rail, the input voltage to J16 must not exceed 3.6 V or damage to those ICs will occur. This option complements the very low power consumption of the ADS4xxx/58B18EVM as the TPS62562 provides excellent power efficiency.

2.2.1.2 Power Supply Option 2

Option 2 supplies power to the 1.8-V analog and digital rails of the ADC by using the TPS79618. The TPS79618 is a low-noise dropout regulator - the 1.5-V dropout voltage (3.3 V to 1.8 V) provides sufficient headroom for maximum PSRR and ADC performance. However, it comes at the expense of higher system power consumption.

2.2.1.3 Power Supply Option 3

Option 3 is used to evaluate ADC performance using an isolated AVDD and DVDD power supply for current-consumption measurements. This option must be used with caution as reversing the power supply or connecting to the wrong connector can result in damage to the EVM. One common usage of this option is to measure the separate current consumption of the relative supplies under particular operating conditions. For this option, the shunts on jumpers JP13 and JP14 are removed and the input power is supplied to the center post of the jumper. For convenience, a ground post is provided next to the center post for header connections that contain power and ground on 0.1-inch centers.

2.2.2 Clock Input

The clock can be supplied to the ADC in several ways. The default clocking option is to supply a single-ended clock directly to the SMA connector, J19, directly. This clock is converted to differential and AC coupled to the ADC by transformer coupling. The clock input must be from a clean, low-jitter source and is commonly filtered external to the board by a narrow bandpass filter. The clock amplitude is commonly set to about 1.5 V peak-to-peak, and the amplitude offset is not an issue due to the AC coupling of the clock input. The clock source is commonly synchronized with the signal generator of the input frequency to keep the clock and IF coherent for meaningful FFT analysis.

Alternatively, the clock may be supplied by an onboard VCXO and CDCE72010 clock buffer. The CDCE72010 clock buffer has been factory programmed to output a clock to the ADC that is 1/4 the rate of the onboard VCXO. While using this clock option, a separate 20-MHz reference clock must be supplied to the CDCE72010 by way of the clock input SMA connector J19. From the CDCE72010, two clocking options to the ADC are possible. A differential LVPECL clock output may be connected to the ADC clock input or a single-ended CMOS clock from the CDCE72010 may be routed to the ADC transformer-coupled clock input through an onboard crystal filter. For better performance, selecting the CMOS clock through a crystal output is recommended. Prior to making any jumper settings and resistor changes, see the schematic located on the TI Web site in the relevant ADS41xx or ADS41Bxx product folder. [Table 2-4](#) displays the various clock option settings. The VCXO and crystal filter do not come populated on the EVM by default, although the CDCE72010 clock buffer is installed.

Table 2-3. Clock Input Jumper Description

EVM Jumper Options	Description	Jumper Setting
JP4	ENABLE VCXO1 TC0-2111	1-2 → VCXO enabled 2-3 → VCXO disabled
J19	SMA connector for clock input	
JP1	CDCE72010 power down	1-2 → CDCE72010 is power down; Open → CDCE72010 is on
JP2	CDCE72010 reset	1-2 → Reset , Open → Normal operation. (default)
R81/107	Clock In or CDC ref. jumper	R81 → J19 supplies clock directly to ADC; R107 → Reference clock for CDCE72010
R113/114/115	Clock input to +ve terminal of T4 for ADC clock	R115 → Connects J19 to ADC; R114 → Connects Y0 output of CDCE72010 (This path has crystal filter) to ADC; R113 → Connects Y1P (Differential LVPECL clock output of CDCE72010) to ADC
R108/110	Clock input to -ve terminal of T4 for ADC clock	R110 → Connects to ground (Default); R108 → Connects to Y1N (Differential clock output of CDCE72010) only to be used with Y1P.
JP8	Mode select pin for CDCE72010	1-2 → High (default), see data sheet of CDCE72010; 2-3 → Ground
R111/112	PLLOCK LED	R111 → Connects to D3 diode; R112 → Ground through 10-nF capacitor
JP10	Aux_sel pin for CDCE72010	1-2 → High, see data sheet of CDCE72010; 2-3 → Ground (Default)

Table 2-4. EVM Clock Input Options

EVM Options	Evaluation Goal	Jumper and Resistor Changes Required	Frequency Input on J19	CDC Configuration Description	Comments
1	Evaluate ADC performance using a sinusoid clock	JP1 → 1-2; JP2 → no shunt; JP4 → 2-3; Install: R81, R110, R115	ADC's Sampling Frequency	NA	Default
2	Evaluate ADC performance using a crystal filtered LVCMOS clock derived from CDCE72010	JP1 → no shunt; JP2 → no shunt; JP4 → 1-2; Install: R107, R110, R114; Remove: R81, R115	20M for VCXO@983.04 MHz	Divide VCXO frequency by 4, output on Y0	Maximum performance
3	Evaluate ADC performance using a differential LVPECL clock	JP1 → no shunt; JP2 → no shunt; JP4 → 1-2; Install: R107, R108, R114; Remove: R81, R110, R115	20M for VCXO@983.04 MHz	Divide VCXO frequency by 4, differential LVPECL Clock output on Y1P and Y1N	Not recommended for most applications

2.2.2.1 Clock Option 1

The Clock Option 1 provides a clock to ADC directly from an external source. For the direct supply of the clock to the ADC, a single-ended square or sinusoidal clock input must be applied to J19. The clock frequency must be within the maximum frequency specified for the ADC. The clock input is converted to a differential signal by a Mini-Circuits™ ADT4-1WT, which has an impedance ratio of 4, implying that voltage applied on J19 is stepped up by a factor of 2. ADC performance in this case depends on the clock source quality. This option is also the default configuration on the EVM, when it is shipped from the factory. The test result using this option is shown in [Figure 5-2](#).

2.2.2.2 Clock Option 2

Option 2 uses the onboard VCXO and CDCE72010 to provide a clock to the ADC. The CDCE72010 is used in SPI mode which uses the internal EEPROM to configure the CDCE72010. The EEPROM is programmed in the factory for a divide-by-4 configuration. The EEPROM configuration is shown in [Figure 2-4](#). The clock at J19 is the reference clock for CDCE72010. The VCXO frequency can be calculated as $F_{vcxo} = F_{out} \times 4$ (F_{out} is the frequency output U0 and U1). The reference clock for CDCE72010 is calculated from $Ref\ Clock = (F_{vcxo} \times 125) / (48 \times 128)$. This is the clock-to-M divider. When VCXO of frequency 983.04 MHz is used, the calculation results in a reference clock of 20 MHz; the clock output on Y0 pin of CDCE72010 is 245.76 MHz. This clock is filtered using the crystal filter with center frequency of 245.76 MHz. By default, the VCXO and the crystal filter are not populated on the EVM, so that the user can populate the components depending on the end application and sampling rate. This configuration is recommended for applications requiring an onboard clock generation scheme. The test result using this option is shown in [Figure 2-4](#).

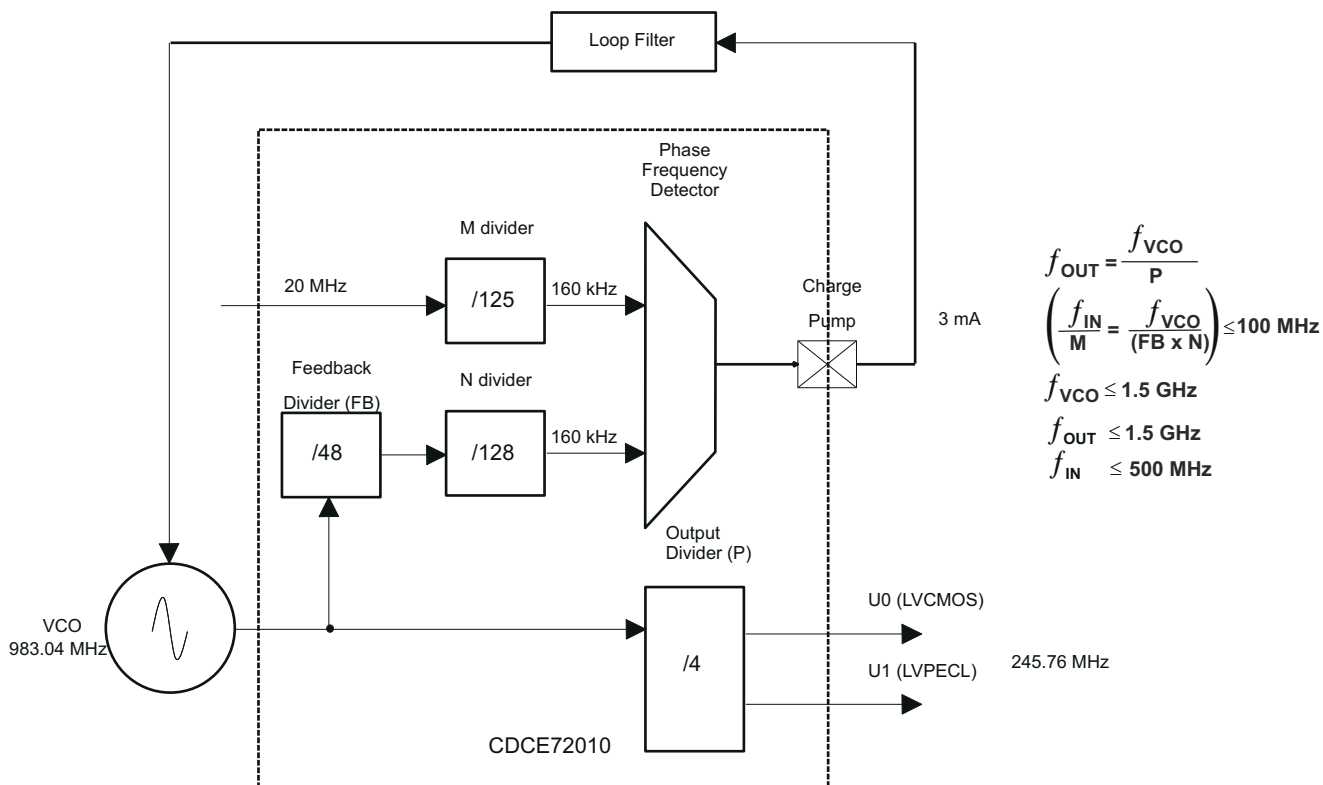

Figure 2-4. CDCE72010 EEPROM Configuration Block Diagram

2.2.2.3 Clock Option 3

Option 3 is used for a differential LVPECL clock. This configuration eliminates the need for a crystal filter. It uses the same EEPROM configuration as Option 2, but in this case, the ADC clock pins are connected to Y1N and Y1P. The jumper setting uses the clock output Y1P and Y1N from CDCE72010, to clock ADC. This configuration is not recommended for SNR critical applications. Notice that the clock frequency does not change. The frequency remains the same as in Clock Option 2. The test result using this option is shown in [Figure 2-4](#).

2.2.3 Analog Inputs

The EVM can be configured to use either a transformer-coupled input or a THS4509 amplifier input, both from a single-ended source. The SMA connector J6 provides the single-ended analog input to the transformer-coupled input of the ADC. The SMA connector J8 is not installed by default, but can be used to bring a differential input clock to the transformer-coupled input or to bring a single-ended input to the THS4509 input circuit. To set the transformer up for one of these options, the EVM must be configured as per the options listed in [Table 2-6](#). Prior to making any jumper changes, see the schematic located on the TI Web site in the relevant ADS41xx or ADS41Bxx product folder.

Table 2-5. Analog Input Jumper Description

EVM Jumper options	Description	Jumper Setting
J6	Analog input single-ended.	
J8	Analog input, can be used with J6 for differential input	Not populated
J9	Power supply +	Apply 5 V
J11	Power Supply -	Ground
R98/106	AMP out+	R106 → Amp out+ is selected as the source of input to ADC; R98 → Use Analog input from J6 as signal source to ADC
R97/99	AMP out-	R99 → Amp out+ is selected as the source of input to ADC; R97 → Use Analog input from J6 as signal source to ADC
R82/96	-Input select	R82 → Differential signal input to transformer T1 (remove R84); R96 → negative input to amplifier
R94/95	+Input select	R94 → single-ended input to transformer T1; R95 → positive input to amplifier
JP7	Power down for amplifier THS4509	2-3 → Pulls up the pin (normal operation or amplifier is ON); 1-2 → Grounds the pin (low-power mode or amplifier is off)

Table 2-6. EVM Analog Input Options

EVM Options	Evaluation Goal	Jumper Changes Required	Voltage on J9 and J11	Analog Signal to ADC	Comments
1	Evaluate ADC performance using direct input to ADC.	Install: R84, R94, R97, R98; Remove: R82, R95, R96, R99, R106	Do not connect	From J6	Default
2	Evaluate ADC performance using input through THS4509	Install: R95, R96, R99, R106; Remove: R82, R84, R94, R97, R98	J9 → 5V, J11 → GND	Signal from J6 is amplified by THS4509	Used if input signal requires amplification.

2.2.3.1 Analog Input Option 1

Option 1 supplies the transformer-coupled input from J6 to ADC. This configuration is the default on the EVM. The test result using this option is shown in [Figure 5-2](#). A double-transformer input circuit is used to provide better differential to single-ended conversion than a single transformer can provide. The transformers used are both of a 1:1 turns ratio, so termination of the 50-Ω input signal path after the transformers can be two 25-Ω resistors terminated to the common-mode voltage (VCM) provided by the ADC.

Following the transformer coupling, surface-mount pads are provided for several input circuits. By default, the input circuit is configured as shown in the ADS4149 data sheet under the recommended input circuit for high-bandwidth (>100-MHz IF) inputs. However, the recommended low-bandwidth input circuit for the ADS4149 can be easily implemented on the surface-mount pads provided.

2.2.3.2 Analog Input Option 2

Option 2 allows the use of an amplifier to provide input to the ADC. TI has a range of wideband operational amplifiers such as THS4508/09/11/13/20. On this EVM, THS4509 is used as an example to amplify the input from J8. The THS4509 is powered up by applying 5 V to J9 and GND to J11. A differential power supply also may be used to power up the amplifier if common-mode biasing is an issue for DC-coupled applications. See the THS4509 data sheet ([SLOS547](#)). The output of the THS4509 is filtered through a band-pass filter before ADC input. The band-pass filter can be designed depending on the end application. By default, the band-pass filter components are not populated as the filter design depends on the end application. The TI schematic provides an example of a filter that is designed for the frequency band of 10 MHz to 58 MHz. When using the suggested filter, be sure to consider the proper value for R23 and R24 resistors, as the ADC may impose limits on how large these resistors may be while the amplifier may impose limits on how low an impedance it can drive. A key point when designing a filter is to design it for proper load termination. Care must be taken when supplying the input to the board, and ensure that the source impedance is 50 Ω. Results can vary due to mismatching of the various source and termination impedances.

2.2.4 Digital Outputs

The LVDS digital outputs can be accessed through the J10 output connector. A parallel 100- Ω termination resistor must be placed at the receiver to properly terminate each LVDS data pair. These resistors are required if the user wants to analyze the signals on an oscilloscope or a logic analyzer. The ADC performance also can be quickly evaluated using the TSW1400 board along with the High Speed Data Converter Pro software as explained in the next section. The TSW1400 automatically terminates the LVDS outputs once the TSW1400 is connected to J10. Alternatively, the ADS41xx/58B18 is supplied with a breakout-board to easily connect the LVDS outputs to a logic analyzer pod. This LVDS breakout-board also properly terminates the LVDS outputs once the breakout board is connected to J10.

The ADS41xx and most other ADCs that may be evaluated on this EVM also have an option to output the digitized parallel data in the form of single-ended CMOS. If single-ended CMOS is desired, header post connector J5 is provided for the CMOS output. In order to use the header J5, a CMOS buffer U7 must be installed in place of a bank of 0- Ω resistors that by default steer the outputs to the LVDS connector J10.

3 TI ADC SPI Control Interface

This section describes the software features accompanying the EVM kit. The ADS41xx EVM control software provides full control of the SPI interface, allowing users to write to any of the ADC registers found in the ADC data sheet. For most ADS4149 (and other ADCs evaluated on this EVM) performance evaluations, users do not need to use the EVM control software to get evaluation results. Users only need to use the ADC SPI control software when the desired feature is inaccessible because the ADC is in parallel interface mode.

3.1 Installing the ADC SPI Interface

ADC SPI control software can be installed on a personal computer by running the setup.exe file located on the TI Web site in a zip file in the EVM product folder. This file installs the graphical user interface (GUI) along with the USB drivers needed to communicate with the USB port that resides on the EVM. The software installation provides for installation in a default directory, which the user may change to some other directory path if desired. After the software is installed, insert the USB cable in the EVM to complete the installation. The Found New Hardware wizard starts and when prompted, users must allow the Windows™ operating system to search for device drivers by checking "Yes, this time only" as seen in Figure 3-1.

Note

Before plugging in the USB cable for the first time, install the TI ADC SPI software. The software installs the drivers necessary for USB communication.

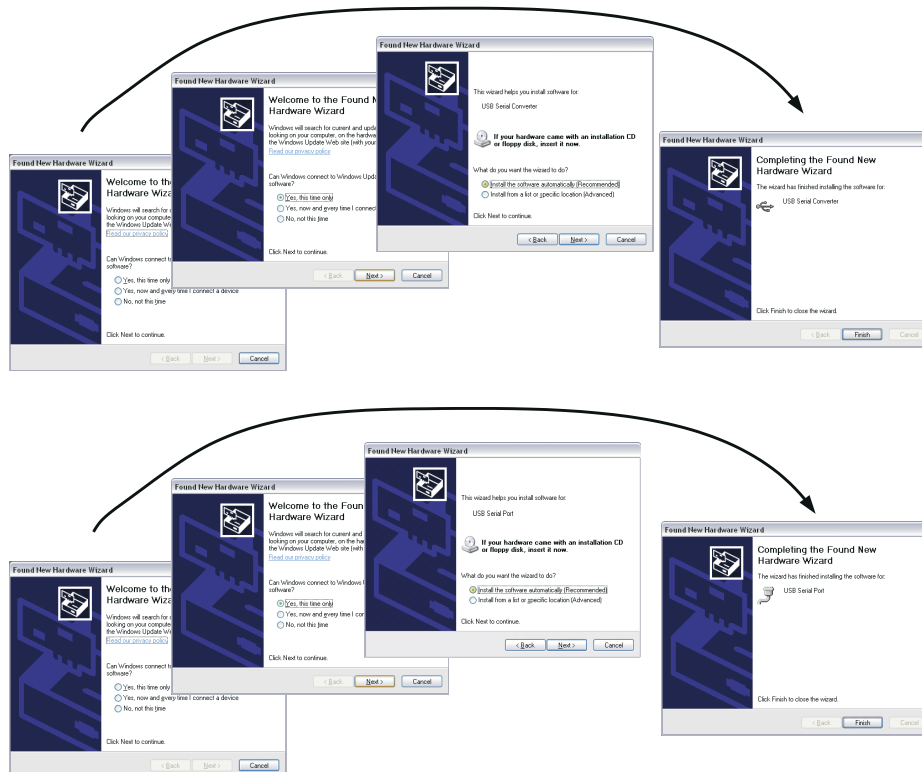

Figure 3-1. Found New Hardware

3.2 Setting Up the EVM for ADC SPI Control

Users who want to use the ADC SPI interface must configure three jumpers for proper control of the SPI bus. By default, the EVM comes with the ADC configured in parallel mode. In order to use the SPI interface to control the ADC modes of operation, users must:

- Move jumper JP12 to short positions 2–3, which places the ADC in serial operation mode.
- Move jumper JP11 to short positions 2–3, which allows the USB circuit to control SDATA.
- Move jumper JP9 to short positions 2–3, which allows the USB circuit to control SEN.

3.3 Using the TI ADC SPI Interface Software

Once the software is installed and the USB cable is connected, three primary modes of operating the software are available: ADS41xx frequently used registers, SPI register writes, and SPI register writes using a script file.

3.3.1 SPI Register Writes

By default the ADS41xx EVM is configured to allow access of the register space in the ADS41xx using the TI ADC SPI user interface. The GUI contains a main and an advanced page but most of the programming can be done on the main tab.

The main page (see Figure 3-2) provides bit switches for easy access of the most frequently used registers. It also offers the option of directly writing data into registers through the address and data field. Additional features like clock edge control or offset compensation are located on the advanced page of the GUI (see Figure 3-3). Current registers being written are displayed on the right side in hexadecimal format as well as in Boolean format on the bottom (16-bit total – 8-bit address and 8-bit data). The user also has the option to load or save a register file.

After power up of the EVM, it is recommended to perform a reset of the USB port of the EVM (button on top).

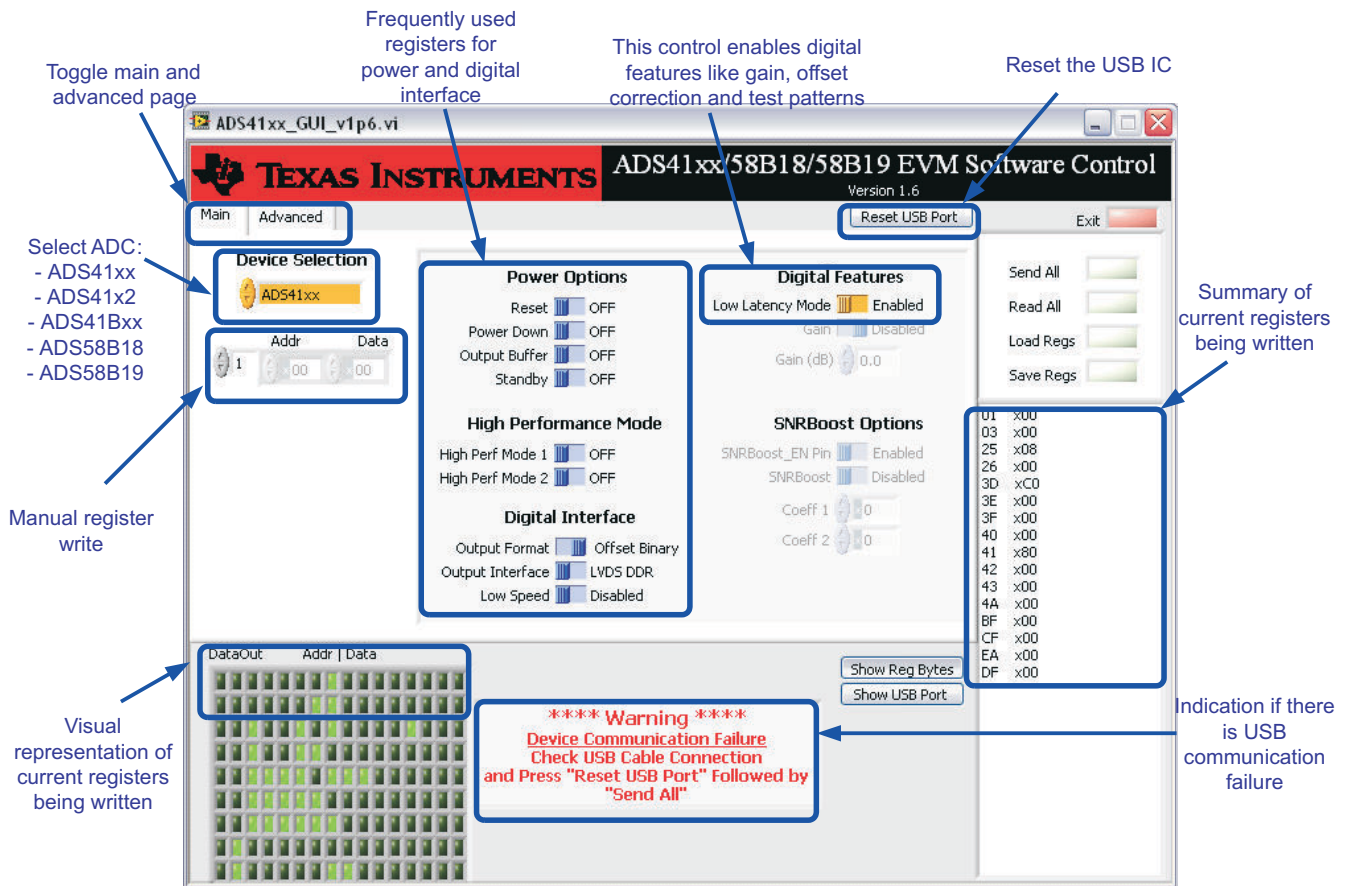

Figure 3-2. GUI Main Page

Change of clock relationship of digital interface

Control of offset correction (enabled by disabling low latency mode)

Enable different output data as well as a custom pattern

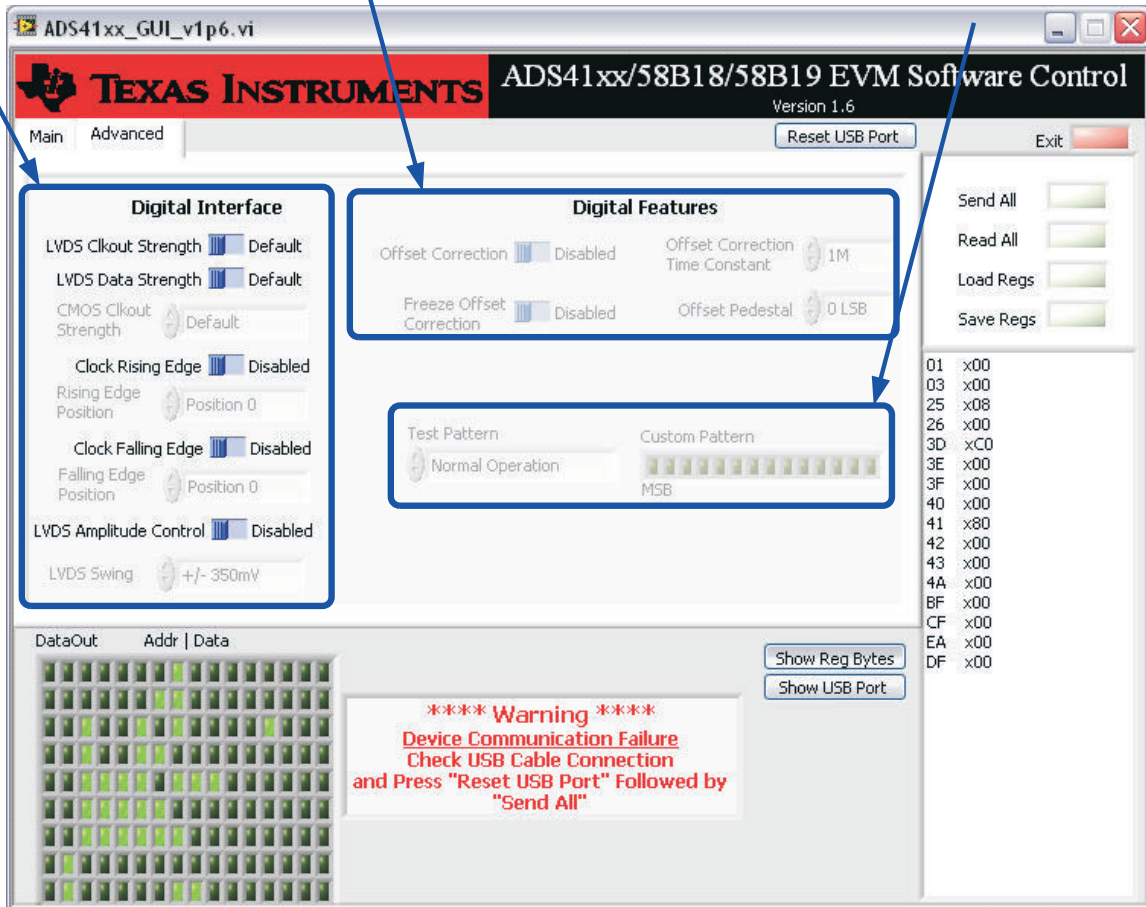
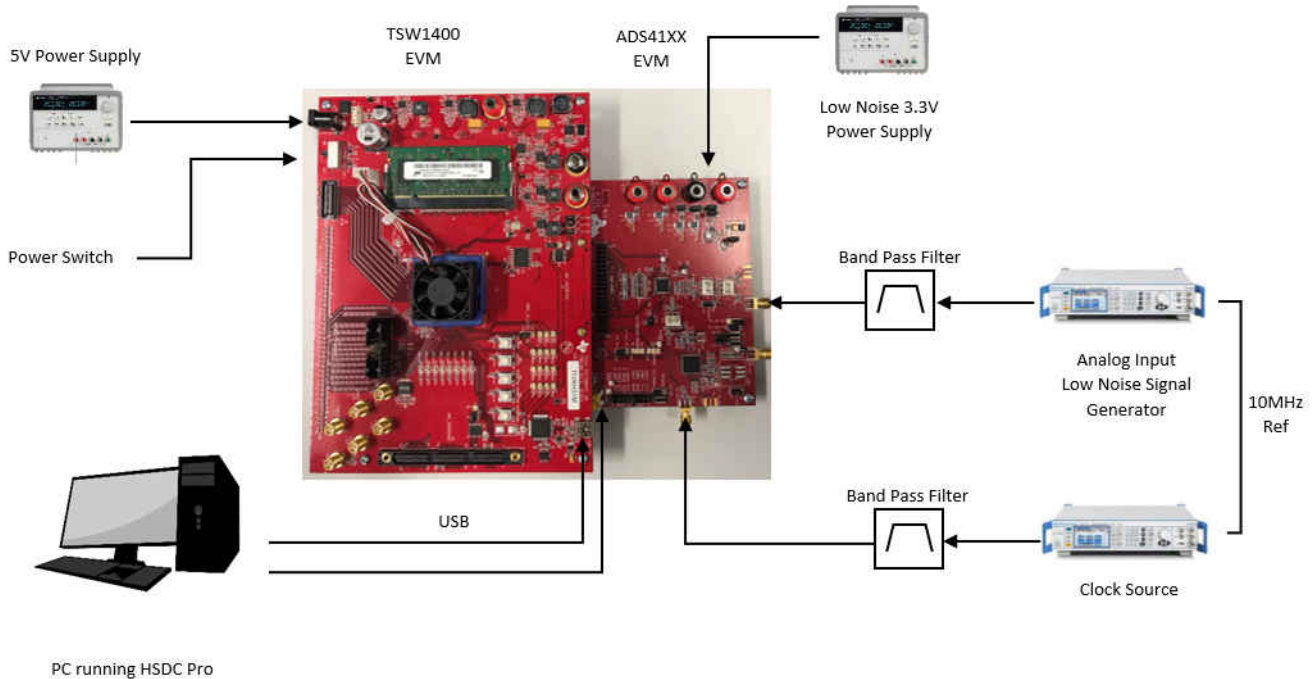

Figure 3-3. GUI Advanced Page

4 Quick Start Setup

- Set up the ADS41xxEVM according the following diagram.
 - Two signal generators are used and externally locked through the 10-MHz reference. Furthermore, bandpass filters on clock and data input are used to minimize spurs and noise created by the signal generators. Depending on filter attenuation, the clock generator amplitude must be set to 10-13 dBm.
 - USB connection of the PC to ADS41xxEVM as well as TSW1400 must be established and if necessary the USB drivers installed accordingly (see [Section 3.2](#)).
 - The ADS41xx EVM requires a 3.3V power supply and the TSW1400 a 5V supply.



- If Serial mode (SPI) is used, ensure that jumpers are set for SPI mode (SCLK, SDATA, SEN).
- Configure the following SPI registers:
 - Reset USB.
 - Reset ADC.
 - Disable low latency mode (ADS41xx only).
 - Enable gain (ADS41xx only).
 - Set gain to 1 dB (ADS41xx only).
- Configure the TSW1400 (see [Figure 5-1](#)).
 - In HSDC Pro, under the 'Select ADC' drop down, select the ADC under test.
 - Under Test Selection, select Single Tone to run a single tone FFT test.
 - Change the ADC Output Data Rate and ADC Input Target Frequency to match those of the signal generator.
 - Press the Capture button to begin capturing data
 - Adjust input signal amplitude until fundamental amplitude reaches ~ -1 dBFS.
- Measurement is illustrated in [Figure 5-2](#).

5 Evaluation

5.1 Register Programming

Early EVMs (serial number 001 to 050) were assembled with preproduction silicon. To obtain optimum SNR and SFDR performance at input frequencies above 130 MHz, it is recommended to set the following registers:

Address	Data
x03	x04
xD3	x40
xDB	xD0

This change is addressed in production silicon.

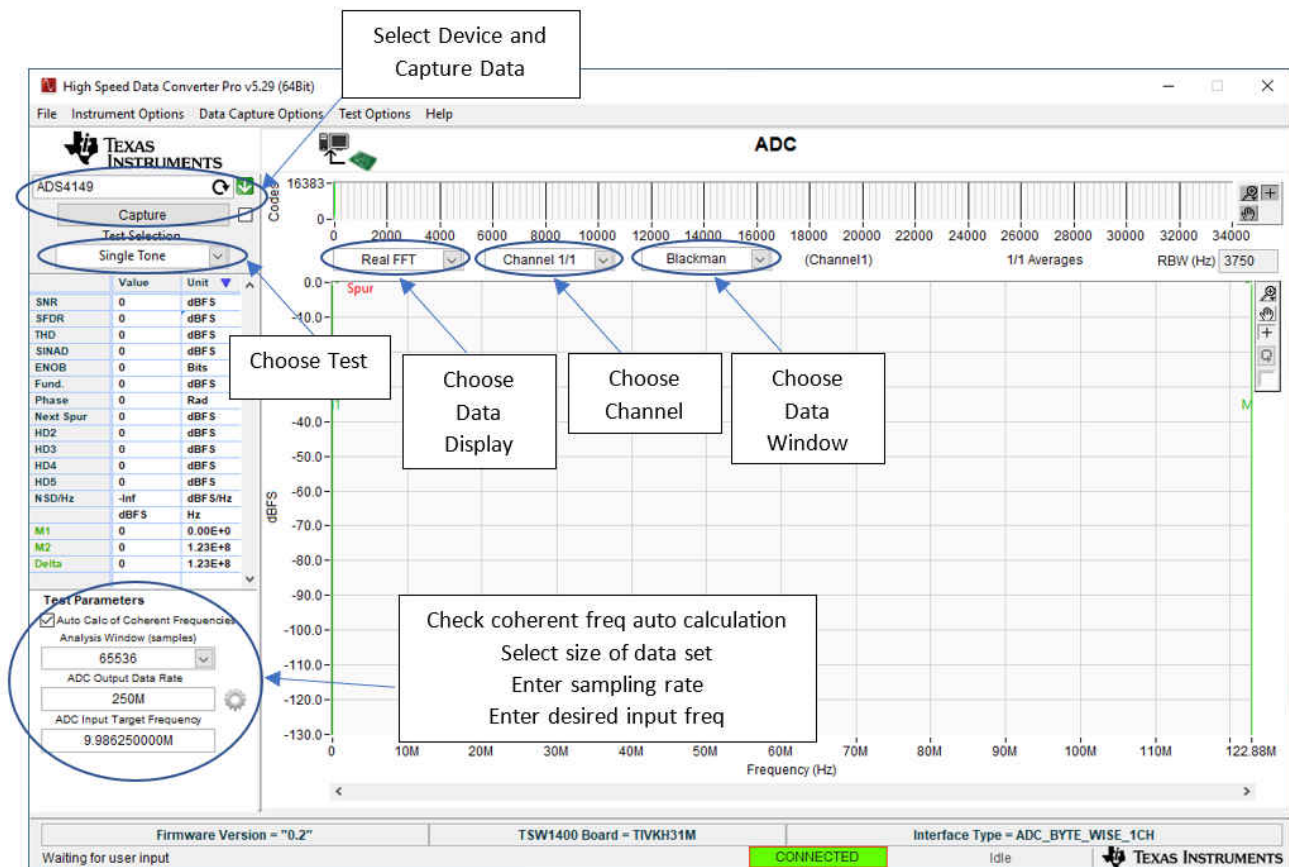

Figure 5-1. TSW1400 GUI Introduction

To start the evaluation with the High Speed Data Converter Pro software, note the following points:

1. Open High Speed Data Converter Pro by going to **Start Menu** → **All Programs** → **Texas Instruments** → **High Speed Data Converter Pro**.
2. When prompted to select the capture board, select the TSW1400 whose serial number corresponds to the serial number on the TSW1400EVM and click OK. This pop-up can also be accessed via **Instrument Options** → **Connect to the Board** when not already connected to a board.
3. When prompted to select a device, select ADC in the drop-down menu.
4. If no firmware is currently loaded, there is a message indicating this. Click on OK.
5. Use the Select ADC drop-down menu at the top left corner to select the device under test.
6. When prompted to update the firmware for the ADC, click Yes and wait for the firmware to download to the TSW1400. This takes a couple of seconds.

7. Enter the desired output data rate into the ADC Output Data Rate field at the bottom left corner then click outside this box or press Return on the PC keyboard to update.
8. Click Capture in HSDC Pro to capture data from the ADC.
9. Adjust the input level signal to attain the dBFS of approximately -1.

5.2 Quick-Test Results

The user can make the jumper setting as mentioned in [Table 1-1](#). In this configuration, the EVM uses an external clock source from J19 and a direct input signal J6 to the ADC. This setup uses Power Option 2 ([Table 2-2](#)), Clock Option 1 ([Table 2-4](#)), and Analog Input Option 1 ([Table 2-6](#)), which is the default on the EVM. [Figure 5-2](#) shows the ADC performance capture using TSW1400 with the input signal of a 10-MHz frequency and clock frequency of 245.76 MHz with ADS4149.

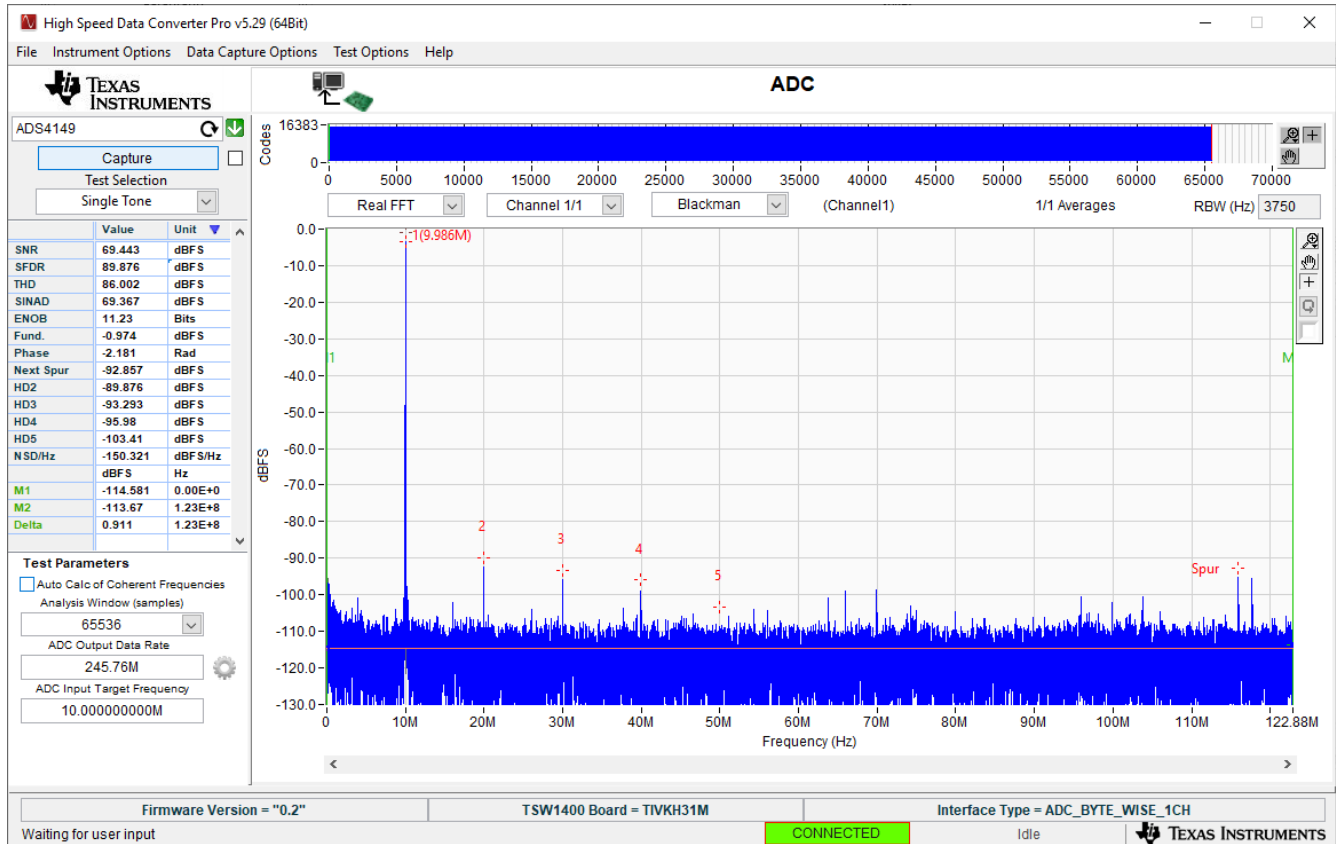

Figure 5-2. Quick-Setup Test Result.

IMPORTANT NOTICE AND DISCLAIMER

TI PROVIDES TECHNICAL AND RELIABILITY DATA (INCLUDING DATA SHEETS), DESIGN RESOURCES (INCLUDING REFERENCE DESIGNS), APPLICATION OR OTHER DESIGN ADVICE, WEB TOOLS, SAFETY INFORMATION, AND OTHER RESOURCES "AS IS" AND WITH ALL FAULTS, AND DISCLAIMS ALL WARRANTIES, EXPRESS AND IMPLIED, INCLUDING WITHOUT LIMITATION ANY IMPLIED WARRANTIES OF MERCHANTABILITY, FITNESS FOR A PARTICULAR PURPOSE OR NON-INFRINGEMENT OF THIRD PARTY INTELLECTUAL PROPERTY RIGHTS.

These resources are intended for skilled developers designing with TI products. You are solely responsible for (1) selecting the appropriate TI products for your application, (2) designing, validating and testing your application, and (3) ensuring your application meets applicable standards, and any other safety, security, regulatory or other requirements.

These resources are subject to change without notice. TI grants you permission to use these resources only for development of an application that uses the TI products described in the resource. Other reproduction and display of these resources is prohibited. No license is granted to any other TI intellectual property right or to any third party intellectual property right. TI disclaims responsibility for, and you will fully indemnify TI and its representatives against, any claims, damages, costs, losses, and liabilities arising out of your use of these resources.

TI's products are provided subject to [TI's Terms of Sale](#) or other applicable terms available either on ti.com or provided in conjunction with such TI products. TI's provision of these resources does not expand or otherwise alter TI's applicable warranties or warranty disclaimers for TI products.

TI objects to and rejects any additional or different terms you may have proposed.

Mailing Address: Texas Instruments, Post Office Box 655303, Dallas, Texas 75265
Copyright © 2022, Texas Instruments Incorporated

Looking for pricing, stock, or lifecycle information?

Click below to explore more details on WIN SOURCE:

⊖ [View ADS4125EVM](#) on WIN SOURCE

⊖ [Texas Instruments](#) Information

Optimize Your Supply Chain with WIN SOURCE Solutions

- ✓ Global Sourcing Solution
- ✓ Obsolete Management
- ✓ Cost Control Management
- ✓ Shortage Management
- ✓ Alternative Solution
- ✓ Excess Inventory Management