



**THE DATASHEET OF
ADRF6612-EVALZ**



Evaluating the **ADRF6612/ADRF6614**, 700 MHz to 3000 MHz Rx Dual Mixer with Integrated Fractional-N PLL and VCO

FEATURES

Full featured evaluation board for the **ADRF6612/ADRF6614**
Single supply: 5 V operation

EQUIPMENT NEEDED

Rohde and Schwarz SMA100 CW generator (3×)
Mini-Circuits® ZFSC-2-2500-S splitter combiner (or equivalent)
Spectrum analyzer, Keysight PSA series or equivalent
Power supply (5.0 V, 1.0 A)
PC running Windows 7 (or Windows XP, or Windows Vista)
USB 2.0 port, recommended (USB 1.1 compatible)
ADRF6612/ADRF6614 evaluation board

SOFTWARE REQUIRED

ADRF6612/ADRF6614 software graphical user interface (GUI)

INTRODUCTION

This user guide allows the user to quickly power up and run the software for the **ADRF6612/ADRF6614** integrated synthesizer and mixers. It complements the **ADRF6612/ADRF6614** data sheet, which should be used in conjunction with this user guide.

POWER, RF, IF, AND USB CONNECTIONS

Figure 1 shows the **ADRF6612/ADRF6614** evaluation board with all required connections for proper operation. All of the connections shown in Figure 2 must be made with the power turned off. When all power, RF, IF, and USB connections are made, the 5 V supply can then be turned on. When the power is turned on initially, the 5 V supply draws approximately 500 mA. When the device is initially programmed via the **ADRF6612/ADRF6614** GUI and USB interface, this current changes as described in the Software GUI Operation, Testing a Number of Evaluation Boards section.

The red and black clips on the evaluation board represent 5 V and GND, respectively. In the upper left of the evaluation board as shown in Figure 2, an SMA cable connects to an external PLL reference source. The dual single-ended RF inputs (RF1 and RF2) are located on the right side of the evaluation board. The IF outputs are located on the top right and bottom right sides of the board. In the default **ADRF6612/ADRF6614** evaluation board configuration, the IF outputs are run single-endedly using the baluns on the board; thus, only one SMA is connected for each IF output.

The USB connector for the software interface is located on the lower left side of the evaluation board. A standard USB cable, PC to mini USB, is required to connect this evaluation board to a PC.

The **ADRF6612/ADRF6614** evaluation board provides all of the support circuitry required to operate the **ADRF6612/ADRF6614** in various modes and configurations. Figure 2 shows the typical bench setup to evaluate the performance of the **ADRF6612/ADRF6614**.

APPLYING POWER

When the 5 V supply is first connected and turned on, the evaluation board draws approximately 500 mA. When the **ADRF6612/ADRF6614** is programmed through the software GUI and the device is fully operational, this current increases to approximately 600 mA.

TABLE OF CONTENTS

Features	1	Software Directory Structure	5
Equipment Needed	1	Software GUI Operation, Testing a Number of Evaluation Boards	6
Software Required	1	Testing the Next Evaluation Board	7
Introduction	1	Evaluation Board Schematics	8
Power, RF, IF, and USB Connections	1	Bill of Materials	11
Applying Power	1		
Revision History	2		
Evaluation Board Hardware	3		

REVISION HISTORY

4/16—Revision 0: Initial Version

EVALUATION BOARD HARDWARE

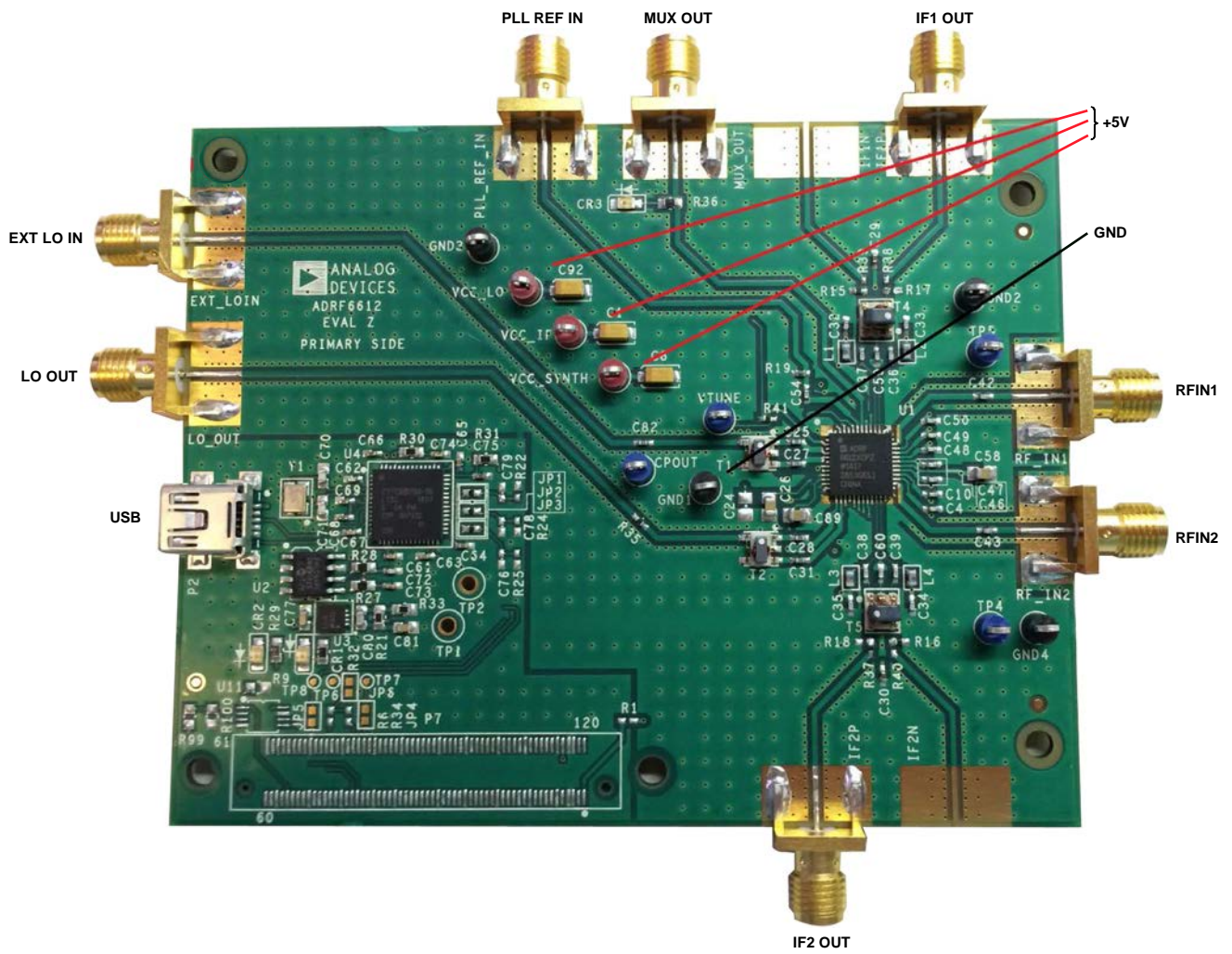

Figure 1. ADRF6612/ADRF6614 Evaluation Board with Connections

14445-001

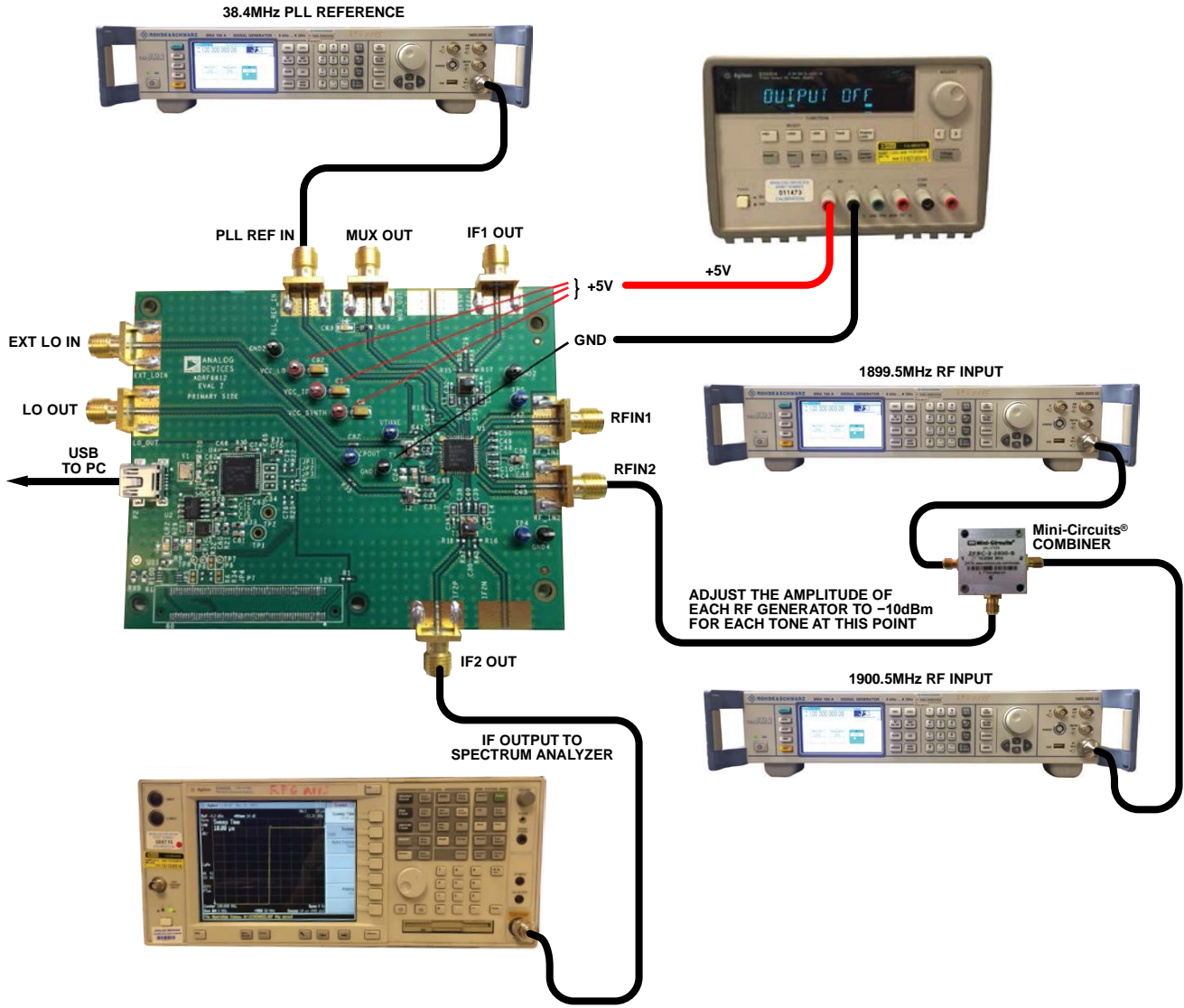

Figure 2. ADRF6612/ADRF6614 Typical Measurement Setup

14445-002

SOFTWARE DIRECTORY STRUCTURE

The software is packaged in the following compressed file:
ADRF6612_14_rev_2p0p0_customer_install.zip

When extracted, the included readme file describes how to install the driver for Windows® XP, Windows Vista™, and Windows 7. This software is compatible with 32-bit and 64-bit systems. When the software installs, the default installation directory opens, as shown in Figure 3.

The GUI itself loads its initial values from a .txt file located in the **device_save_states** subdirectory, as shown in Figure 4. The user can edit this file or save it to a different file name to modify the start-up conditions.

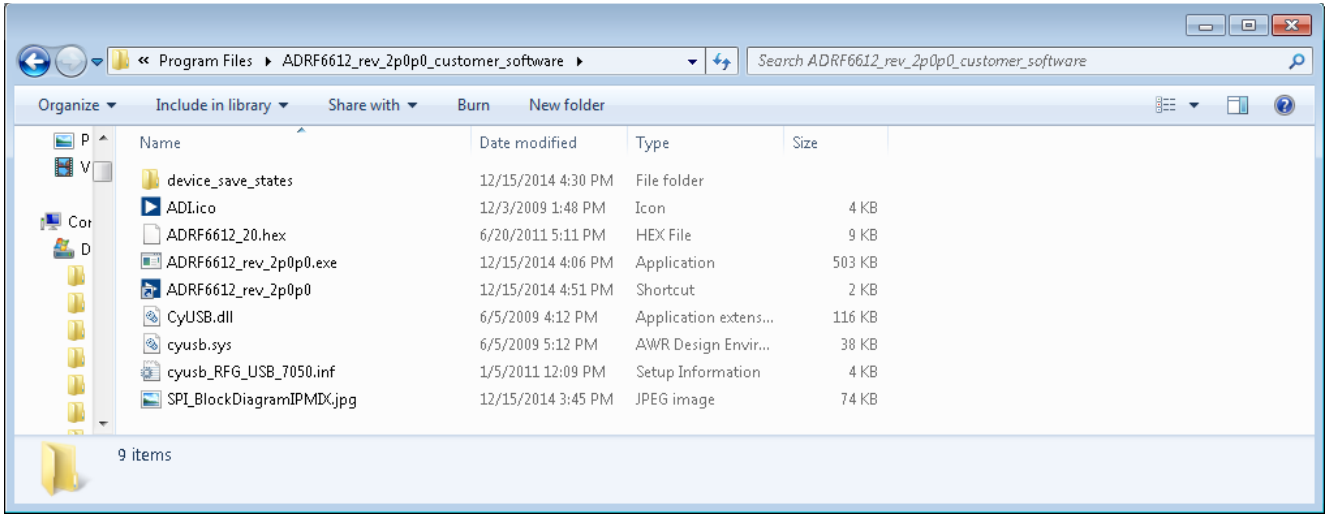

Figure 3. Default Installation Directory for ADRF6612/ADRF6614 Software

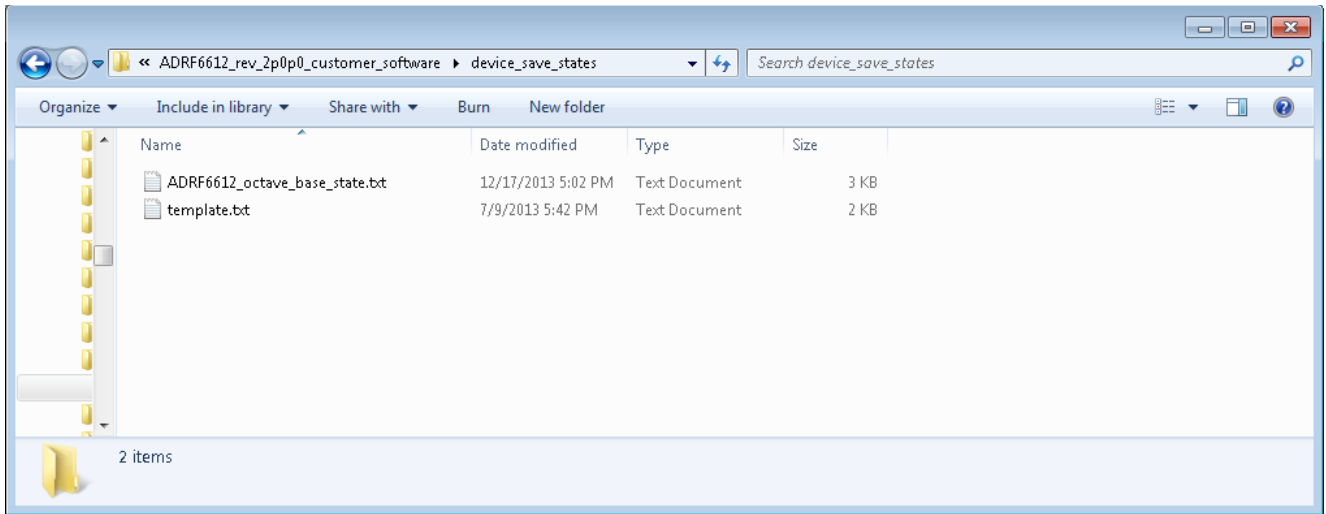

Figure 4. Device Save States Subdirectory

SOFTWARE GUI OPERATION, TESTING A NUMBER OF EVALUATION BOARDS

It is important to note that when entering data into any of the text fields in this GUI, the ENTER key must be pressed when the input is complete. This action updates the variables in the software so that the ADRF6612/ADRF6614 are programmed

with these values during the next programming step (that is, selecting a new value from any of the drop-down menus or clicking INIT).

When the software starts, it loads the initial values from the .txt files described in the Software Directory Structure section. As an example, when the GUI starts, it opens as shown in Figure 5.

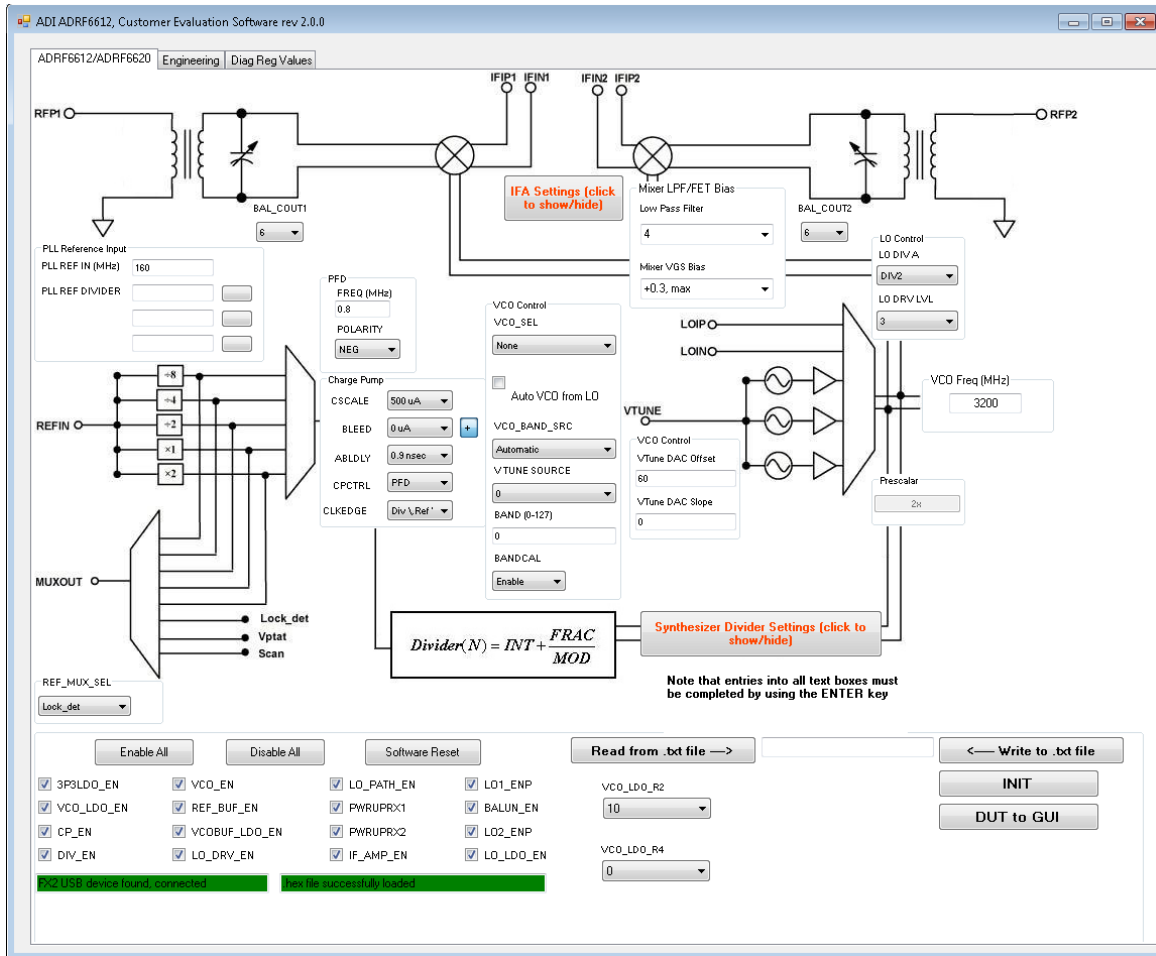

Figure 5. Software GUI for the ADRF6612/ADRF6614 (Note that Green Indicators Show Proper USB Connection)

Test and Programming Sequence

The sequence for setting up the test and programming the [ADRF6612/ADRF6614](#) for proper operation is as follows:

1. Adjust the amplitude of each generator so that each tone on the output of the combiner is at -10 dBm. Ideally, use an SMA barrel to connect the combiner output to the RF input of the [ADRF6612/ADRF6614](#). If this is not possible, use a short as possible cable to minimize cable loss at this point.
2. Set the spectrum analyzer to a center frequency of 203 MHz with a span of 25 MHz, set the input attenuation to 30 dB, and set VBW and RBW to automatic.
3. Click **INIT** (lower right) to load most of the default conditions into the [ADRF6612/ADRF6614](#) registers.
4. Select the **Auto VCO** check box in the center of the **VCO Control** area of the GUI.
5. Enter 38.4 in the **PLL REF IN (MHz)** box in the **PLL Reference Input** area n of the GUI (center left) to set the PLL reference frequency.
6. Enter a value of 1 in the first **PLL REF DIVIDER** box in the **PLL Reference Input** area of the GUI.
7. Click the button to the right of the **PLL REF DIVIDER** box to select the divider value of 1 just entered. The PFD frequency field to the right of the **FREQ (MHz)** button then changes to read 38.4.
8. Click **Synthesizer Divider Settings** in the middle of the GUI to open the Synthesizer Divider Settings dialog box as shown in Figure 7.
9. Select **FRAC** from the **DIV_MODE** drop-down menu. Set the LO output frequency to 1697 MHz by entering 1697 in the **LO OUT FREQ (MHz)** box, and then click **SET**.

At this point, if everything is set up correctly, the spectrum analyzer display appears similar to Figure 6.

These steps complete the testing of Channel 2. To test Channel 1, remove the RF connection from RF Port 2 and connect it to RF Port 1. Additionally, disconnect the IF connection from IF Port 2 and connect it to IF Port 1. The spectrum analyzer display is similar to that in Figure 6.

TESTING THE NEXT EVALUATION BOARD

To test the next evaluation board, disconnect and reconnect all signal, power, and USB connections. It is not necessary to close the software GUI. Reconnect all connections on the next board to be tested. When all connections are made, it is only necessary to click **INIT** to place the next [ADRF6612/ADRF6614](#) evaluation board into a completely operational state. The output spectrum is visible as shown in Figure 6.

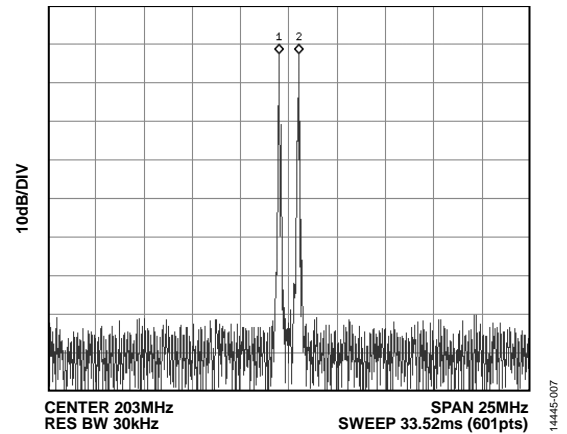

Figure 6. [ADRF6612/ADRF6614](#) Two-Tone Spectral Output

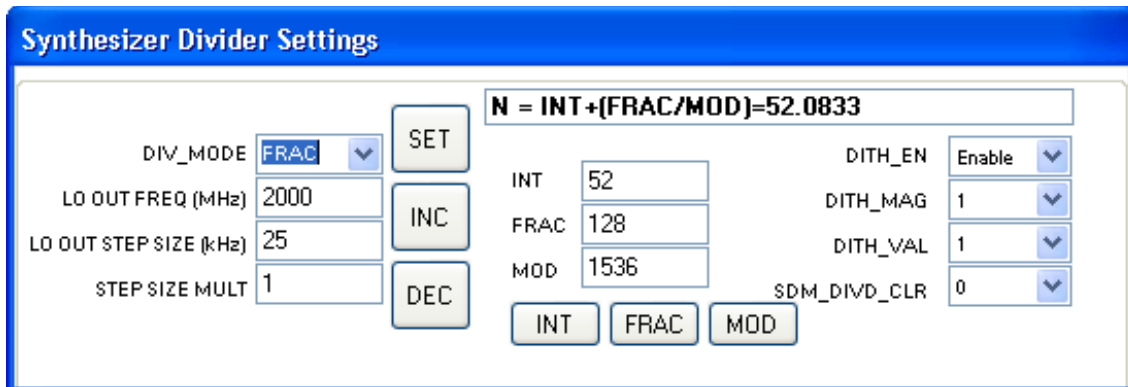

Figure 7. Synthesizer Divider Settings Dialog Box

EVALUATION BOARD SCHEMATICS

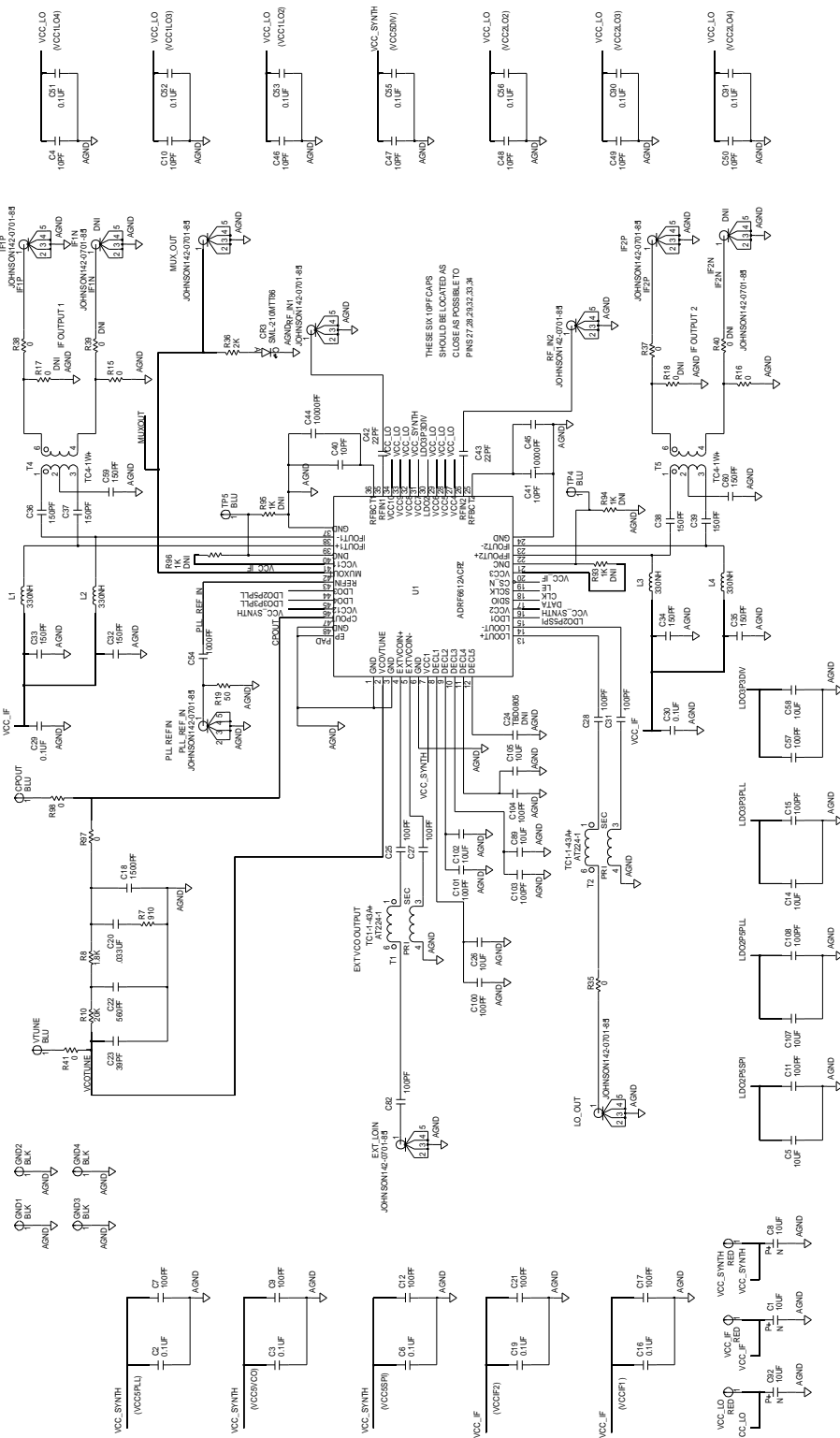

Figure 8. ADRF6612/ADRF6614 Evaluation Board Schematic, Main Circuitry

ALL 100PF DECOUPLING CAPS SHOULD BE AS CLOSE AS POSSIBLE TO THE PINS ON THE CHIP

BILL OF MATERIALS

Table 1. Bill of Materials

Qty.	Reference Designator	Description	Value	Manufacturer	Part No.
1	PCB	PCB	PCB	Analog Devices, Inc.	08_035817C
3	C1, C8, C92	Capacitors, tantalum	10 μ F	AVX	TAJA106K010RNJ
11	C4, C10, C40, C41, C46 to C50, C62, C72	Capacitors, multilayer ceramic, NP0 0402	10 pF	Phycomp (Yageo)	CC0402JRNPO9BN100
18	C7, C9, C11, C12, C15, C17, C21, C25, C27, C28, C31, C57, C82, C100, C101, C103, C104, C108	Capacitors, Chip monolithic ceramic, COG 0402	100 pF	Murata	GRM1555C1H101JD01D
8	C5, C14, C26, C58, C89, C102, C105, C107	Capacitors, ceramic monolithic	10 μ F	Murata	GRM21BR61C106KE15L
25	C2, C3, C6, C16, C19, C29, C30, C51 to C53, C55, C56, C61, C63 to C69, C73 to C75, C90, C91	Capacitors, ceramic, X7R 0402	0.1 μ F	Murata	GRM155R71C104KA88D
1	C18	Capacitor, ceramic, X7R	1500 pF	Phycomp (Yageo)	2238 586 15625
1	C20	Capacitor, ceramic	0.033 μ F	KEMET	C0603C333J3RACTU
1	C22	Capacitor, monolithic ceramic, NP0	560 pF	Murata	GRM1885C1H561JA01D
1	C23	Capacitor, ceramic, NP0	39 pF	Phycomp (Yageo)	2238 867 15399
10	C32 to C39, C59, C60	Capacitors, ceramic, COG 0402	150 pF	Murata	GRM1555C1H151JA01D
2	C42, C43	Capacitors, ceramic	22 pF	Phycomp (Yageo)	0402CG220J9B200
2	C44, C45	Capacitors, ceramic chip, X7R 0402	10,000 pF	TDK	C1005X7R1E103K
1	C54	Capacitor, ceramic, COG 0402	1000 pF	Murata	GRM1555C1H102JA01
2	C70, C71	Capacitor, ceramic, NP0	22 pF	Phycomp (Yageo)	CC0603JRNPO9BN220
2	C77, C81	Capacitor, monolithic ceramic, X5R	1 μ F	Murata	GRM188R61E105KA12D
1	C80	Capacitor, chip monolithic ceramic, COG 0603	1000 pF	Murata	GRM1885C1H102JA01D
4	TP4, TP5, CPOUT, VTUNE	Connector, PCB test point, blue	Blue	Components Corporation	TP104-01-06
3	CR1 to CR3	LED, 570NM WTR, CLR 0805, SMD (green)	SML-210MTT86	Rohm	SML-210MTT86
8	IF1P, IF2P, LO_OUT, RF_IN1, RF_IN2, MUX_OUT, EXT_LOIN, PLL_REF_IN	Connector, PCB coaxial SMA, end launch	142-0701-851	Johnson	142-0701-851
4	GND1 to GND4	Connector, PCB test point, black	Black	Components Corporation	TP-104-01-00
4	L1 to L4	Inductors, SM	330 nH	Coilcraft	0603CS-R33XJLW
1	P2	Connector, PCB receptacle mini USB, Type B SMT	897-43-005-00-100001	Mill-Max	897-43-005-00-100001
1	R10	Resistor, precision thick film chip, R0402	20 k Ω	Panasonic	ERJ-2RKF2002X
9	R15 to R17, R35, R37, R38, R41, R97, R98	Use E003438 from cell Resistor JMPROPEN or Resistor JMPRSHRT	0 Ω	Panasonic	ERJ-2GE0R00X
1	R19	Resistor, high frequency chip, 0402	50 Ω	VISHAY	FC0402E50R0FST1
1	R21	Resistor, film chip thick	140 k Ω	NIC Components Corporation	NRC06F1403TRF
5	R27 to R29, R32, R36	Resistors, film, SMD 0603	2 k Ω	Phycomp (Yageo)	9C06031A2001FKHFT

Qty.	Reference Designator	Description	Value	Manufacturer	Part No.
2	R30, R31	Resistors, precision thick film chip	100 k Ω	Panasonic	ERJ-3EKF1003V
1	R33	Resistor, precision thick film chip, 0603	78.7 k Ω	Panasonic	ERJ-3EKF7872V
1	R7	Resistor, chip, SMD 0603	910 Ω	Panasonic	ERA-3YEB911V
1	R8	Resistor, thick film chip	1.8 k Ω	Panasonic	ERJ-2GEJ182X
2	T1, T2	XFMR RF SMT	TC1-1-43A+	Mini Circuits	TC1-1-43A+
2	T4, T5	XFMR RF with customized pad	TC4-1W+	Mini Circuits	TC4-1W+
1	U1	IC, dual passive receive mixer, PREL	ADRF6612ACPZ/ ADRF6614ACPZ	Analog Devices	ADRF6612ACPZ/ ADRF6614ACPZ
1	U2	IC, 64 kb EEPROM	24LC64-I-SN	Microchip	24LC64-I-SN
1	U3	IC, high accuracy, low I _Q , adjustable low dropout regulator	ADP3334ACPZ	Analog Devices	ADP3334ACPZ
1	U4	IC, HS USB peripheral	CY7C68013A-56LTXC	Cypress Semiconductor	CY7C68013A-56LTXC
3	VCC_IF, VCC_LO, VCC_SYNTH	Connectors, PCB test point, red	Red	Components Corporation	TP-104-01-02
1	Y1	IC, crystal SMD	24.000000MEGHZ	NDK	NX3225SA-24.000000MHZ
2	IF1N, IF2N (DNI)	Connectors, PCB coaxial SMA, end launch	Johnson 142-0701-851	Johnson	142-0701-851
1	P7 (DNI)	Connector, PCB vertical type receptacle SMD	FX8-120S-SV(21)	HRS	FX8-120S-SV(21)
6	R1, R6, R18, R34, R39, R40 (DNI)	Use E003438 from cell Resistor JMPROPEN or Resistor JMPRSHRT	0 Ω	Panasonic	ERJ-2GE0R00X
2	R9, R100 (DNI)	Resistor precision thick film chip	100 k Ω	Panasonic	ERJ-3EKF1003V
7	R22, R24, R25, R93 to R96 (DNI)	Resistor precision thick film chip, R0402	1 k Ω	Panasonic	ERJ-2RKF1001X
2	TP1, TP2 (DNI)	Connectors, PCB test point, black	Black	Components Corporation	TP-104-01-00
1	U11 (DNI)	IC, 32 kb serial EEPROM	24LC32A-I/MS	Microchip	24LC32A-I/MS

NOTES



ESD Caution

ESD (electrostatic discharge) sensitive device. Charged devices and circuit boards can discharge without detection. Although this product features patented or proprietary protection circuitry, damage may occur on devices subjected to high energy ESD. Therefore, proper ESD precautions should be taken to avoid performance degradation or loss of functionality.

Legal Terms and Conditions

By using the evaluation board discussed herein (together with any tools, components documentation or support materials, the "Evaluation Board"), you are agreeing to be bound by the terms and conditions set forth below ("Agreement") unless you have purchased the Evaluation Board, in which case the Analog Devices Standard Terms and Conditions of Sale shall govern. Do not use the Evaluation Board until you have read and agreed to the Agreement. Your use of the Evaluation Board shall signify your acceptance of the Agreement. This Agreement is made by and between you ("Customer") and Analog Devices, Inc. ("ADI"), with its principal place of business at One Technology Way, Norwood, MA 02062, USA. Subject to the terms and conditions of the Agreement, ADI hereby grants to Customer a free, limited, personal, temporary, non-exclusive, non-sublicensable, non-transferable license to use the Evaluation Board FOR EVALUATION PURPOSES ONLY. Customer understands and agrees that the Evaluation Board is provided for the sole and exclusive purpose referenced above, and agrees not to use the Evaluation Board for any other purpose. Furthermore, the license granted is expressly made subject to the following additional limitations: Customer shall not (i) rent, lease, display, sell, transfer, assign, sublicense, or distribute the Evaluation Board; and (ii) permit any Third Party to access the Evaluation Board. As used herein, the term "Third Party" includes any entity other than ADI, Customer, their employees, affiliates and in-house consultants. The Evaluation Board is NOT sold to Customer; all rights not expressly granted herein, including ownership of the Evaluation Board, are reserved by ADI. CONFIDENTIALITY. This Agreement and the Evaluation Board shall all be considered the confidential and proprietary information of ADI. Customer may not disclose or transfer any portion of the Evaluation Board to any other party for any reason. Upon discontinuation of use of the Evaluation Board or termination of this Agreement, Customer agrees to promptly return the Evaluation Board to ADI. ADDITIONAL RESTRICTIONS. Customer may not disassemble, decompile or reverse engineer chips on the Evaluation Board. Customer shall inform ADI of any occurred damages or any modifications or alterations it makes to the Evaluation Board, including but not limited to soldering or any other activity that affects the material content of the Evaluation Board. Modifications to the Evaluation Board must comply with applicable law, including but not limited to the RoHS Directive. TERMINATION. ADI may terminate this Agreement at any time upon giving written notice to Customer. Customer agrees to return to ADI the Evaluation Board at that time. LIMITATION OF LIABILITY. THE EVALUATION BOARD PROVIDED HEREUNDER IS PROVIDED "AS IS" AND ADI MAKES NO WARRANTIES OR REPRESENTATIONS OF ANY KIND WITH RESPECT TO IT. ADI SPECIFICALLY DISCLAIMS ANY REPRESENTATIONS, ENDORSEMENTS, GUARANTEES, OR WARRANTIES, EXPRESS OR IMPLIED, RELATED TO THE EVALUATION BOARD INCLUDING, BUT NOT LIMITED TO, THE IMPLIED WARRANTY OF MERCHANTABILITY, TITLE, FITNESS FOR A PARTICULAR PURPOSE OR NON-INFRINGEMENT OF INTELLECTUAL PROPERTY RIGHTS. IN NO EVENT WILL ADI AND ITS LICENSORS BE LIABLE FOR ANY INCIDENTAL, SPECIAL, INDIRECT, OR CONSEQUENTIAL DAMAGES RESULTING FROM CUSTOMER'S POSSESSION OR USE OF THE EVALUATION BOARD, INCLUDING BUT NOT LIMITED TO LOST PROFITS, DELAY COSTS, LABOR COSTS OR LOSS OF GOODWILL. ADI'S TOTAL LIABILITY FROM ANY AND ALL CAUSES SHALL BE LIMITED TO THE AMOUNT OF ONE HUNDRED US DOLLARS (\$100.00). EXPORT. Customer agrees that it will not directly or indirectly export the Evaluation Board to another country, and that it will comply with all applicable United States federal laws and regulations relating to exports. GOVERNING LAW. This Agreement shall be governed by and construed in accordance with the substantive laws of the Commonwealth of Massachusetts (excluding conflict of law rules). Any legal action regarding this Agreement will be heard in the state or federal courts having jurisdiction in Suffolk County, Massachusetts, and Customer hereby submits to the personal jurisdiction and venue of such courts. The United Nations Convention on Contracts for the International Sale of Goods shall not apply to this Agreement and is expressly disclaimed.



©2016 Analog Devices, Inc. All rights reserved. Trademarks and registered trademarks are the property of their respective owners.
UG14445-0-4/16(0)



www.analog.com

Looking for pricing, stock, or lifecycle information?

Click below to explore more details on WIN SOURCE:

-  [View ADRF6612-EVALZ on WIN SOURCE](#)
-  [Analog Devices Inc. Information](#)

Optimize Your Supply Chain with WIN SOURCE Solutions

-  Global Sourcing Solution
-  Obsolete Management
-  Cost Control Management
-  Shortage Management
-  Alternative Solution
-  Excess Inventory Management