



**THE DATASHEET OF  
ADP5350ACPZ-1-R7**



### FEATURES

#### Switching mode USB battery charger

- High accuracy and programmable charge terminal voltage and charge current
- 3 MHz buck for high efficiency and small footprint
- Tolerant input voltage from  $-0.5\text{ V}$  to  $+20\text{ V}$  (USB  $V_{\text{BUSX}}$ )
- Power path control allows system to operate with dead or missing battery
- Compliant with JEITA charge temperature specification
- Voltage-based state of charge (SOC) calculation algorithm
- Extra low quiescent current in sleep mode
- Battery impedance chemistry (Li-Ion) compensation
- Battery temperature compensation
- No need for external sense resistor
- Boost regulator with 5-channel LED driver
- Support up to 4 LED in series or in parallel
- 5 independent programmable LED current sinks
- 64 programmable LED current levels (up to 20 mA)
- Programmable on and off timer for LED blinking
- Adaptive headroom control to maximize the efficiency
- Three 150 mA linear LDO regulators
- Ultralow  $I_q$  with zero load at  $1\ \mu\text{A}$  typical for LDO1
- Optional load-switch full turn-on mode
- Full I<sup>2</sup>C programmability with dedicated interrupt pin

### APPLICATIONS

- Rechargeable Li-Ion and Li-Ion polymer battery-powered devices
- Portable consumer devices
- Portable medical devices
- Portable instrumentation devices
- Wearable devices

### GENERAL DESCRIPTION

The ADP5350, a power management IC (PMIC), combines one high performance buck regulator for single Li-Ion/Li-Ion polymer battery charging, a fuel gauge, a highly programmable boost regulator for LED backlight illumination, and three 150 mA LDO regulators.

The ADP5350 operates in trickle charge mode and in constant current (CC) and constant voltage (CV) fast charge mode. It features an internal field effect transistor (FET) that permits battery isolation on the system power side.

The ADP5350 fuel gauge is a space-saving and low current consuming solution. It is optimal for rechargeable Li-Ion battery-powered devices, and features a voltage-based, battery SOC measurement function.

Rev. B

[Document Feedback](#)

Information furnished by Analog Devices is believed to be accurate and reliable. However, no responsibility is assumed by Analog Devices for its use, nor for any infringements of patents or other rights of third parties that may result from its use. Specifications subject to change without notice. No license is granted by implication or otherwise under any patent or patent rights of Analog Devices. Trademarks and registered trademarks are the property of their respective owners.

### TYPICAL APPLICATION CIRCUIT

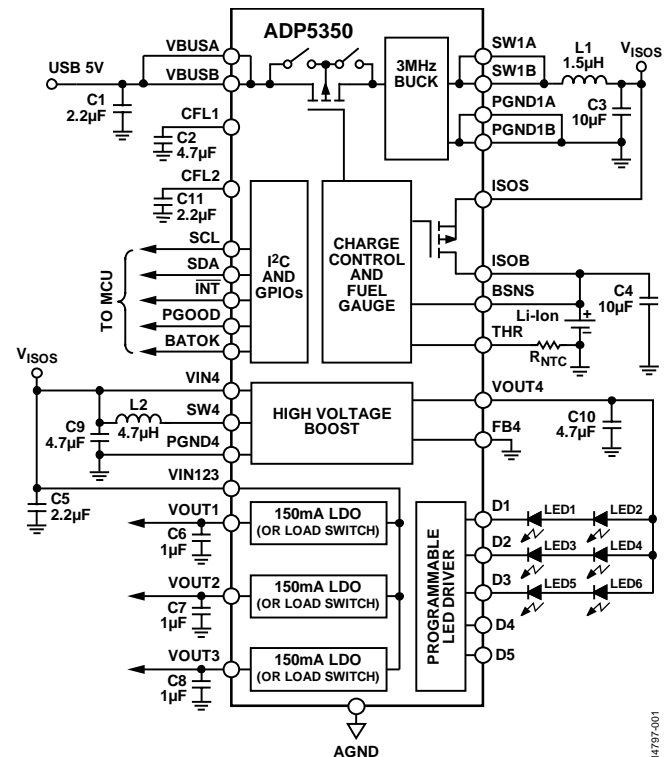

Figure 1.

The ADP5350 boost regulator operates at a 1.5 MHz switching frequency. It can be operated as a constant voltage regulator or as a supplemental constant current regulator for multiple LED backlight drivers.

The ADP5350 LED drivers can support a wide range of LED backlight configurations, either multiple LEDs in parallel or in series.

The ADP5350 low dropout (LDO) regulators are optimized to operate at low shutdown current and quiescent current to extend battery life. The device also operates as a load switch that can be fully turned off or on.

The I<sup>2</sup>C-compatible interface enables the programmability of all parameters, including status bit readback for operation monitoring and safety control.

The ADP5350 operates over the  $-40^{\circ}\text{C}$  to  $+125^{\circ}\text{C}$  junction temperature range and is available in a 32-lead, 5 mm  $\times$  5 mm LFCSP package and a 32-ball, 3 mm  $\times$  3 mm WLCSP package.

## TABLE OF CONTENTS

Features .....	1	Battery Isolation FET .....	23
Applications .....	1	Battery Detection .....	23
General Description .....	1	Battery Temperature .....	24
Typical Application Circuit .....	1	Battery Charger Operational Flowchart.....	26
Revision History .....	2	Battery Voltage-Based Fuel Gauge .....	26
Detailed Functional Block Diagram .....	3	Flowchart of SOC Calculation.....	28
Specifications.....	4	Boost and White LED Drivers.....	29
Battery Charger Specifications .....	4	Linear Low Dropout (LDO) Regulators.....	33
Battery Fuel Gauge Specifications .....	6	Thermal Management .....	34
Boost and LED Driver Specifications .....	7	I <sup>2</sup> C Interface .....	35
LDO Specifications .....	8	I <sup>2</sup> C Addresses .....	35
Recommended Input and Output Capacitance and Inductance Specifications.....	10	SDA and SCL Pins.....	35
I <sup>2</sup> C-Compatible Interface Timing Specifications.....	11	Default Reset.....	35
Absolute Maximum Ratings.....	12	Interrupts.....	36
Thermal Resistance .....	12	Control Register Map.....	37
ESD Caution.....	12	Register Bit Descriptions.....	39
Pin Configuration and Function Descriptions.....	13	Applications Information .....	58
Typical Performance Characteristics .....	15	External Components .....	58
Typical Waveforms .....	19	PCB Layout Guidelines.....	60
Theory of Operation .....	21	Typical Application Circuits .....	61
Battery Charger Overview.....	21	Factory-Programmable Options .....	62
Charger Modes.....	22	Outline Dimensions .....	63
		Ordering Guide .....	63

## REVISION HISTORY

### 5/2018—Rev. A to Rev. B

Changes to Table 1 .....	4	Changes to Table 1 .....	3
Changes to Table 3 .....	7	Changes to Table 4.....	8
Changes to Table 4.....	8	Changes to Figure 4 Caption and Table 9 Title .....	13
Change to Battery Pack Thermistor Input Section .....	24	Added Figure 5; Renumbered Sequentially .....	14
Change to Shutdown Current, Table 15 .....	27	Added Table 10; Renumbered Sequentially .....	14
Changes to Figure 50.....	31	Change to Figure 15 Caption .....	16
Change to Address 0x0C, Table 18.....	37	Change to Figure 23 Caption .....	17
Change to Bits[1:0], Table 23 .....	41	Change to Figure 24 Caption .....	18
Change to Bit 4 Mnemonic, Table 70.....	53	Changes to Figure 59.....	60
Updated Outline Dimensions .....	63	Updated Outline Dimensions.....	61
		Changes to Ordering Guide.....	61

### 11/2017—Rev. 0 to Rev. A

Added CB-32-1 .....	Throughout
Change to General Description .....	1

### 2/2017—Revision 0: Initial Version

# DETAILED FUNCTIONAL BLOCK DIAGRAM



14797-022

Figure 2. Detailed Functional Block Diagram

## SPECIFICATIONS

## BATTERY CHARGER SPECIFICATIONS

$-40^{\circ}\text{C} < T_J < 125^{\circ}\text{C}$ ,  $V_{\text{VBUSx}} = 5.0\text{ V}$ ,  $R_{\text{NTC}} = 47\text{ k}\Omega$ ,  $V_{\text{VIN4}} = V_{\text{VIN123}} = V_{\text{ISOS}} = 3.6\text{ V}$ ,  $C1 = 2.2\text{ }\mu\text{F}$ ,  $C2 = 4.7\text{ }\mu\text{F}$ ,  $C3 = 10\text{ }\mu\text{F}$ ,  $C4 = 10\text{ }\mu\text{F}$ ,  $C11 = 2.2\text{ }\mu\text{F}$ ,  $L1 = 1.5\text{ }\mu\text{H}$ , all registers are at default values, unless otherwise noted.

Table 1.

Parameter	Symbol	Test Conditions/Comments	Min	Typ	Max	Unit
<b>GENERAL PARAMETERS</b>						
Undervoltage Lockout	$V_{\text{UVLO}}$	$T_J = 0^{\circ}\text{C}$ to $85^{\circ}\text{C}$ On BSNS, rising threshold, no $V_{\text{VBUSx}}$ On BSNS, falling threshold, no $V_{\text{VBUSx}}$	2.2	2.45 2.3	2.6	V V
Input Current Limit	$I_{\text{LIM}}$	Set $\text{ILIM}[3:0] = 100\text{ mA}$ Set $\text{ILIM}[3:0] = 500\text{ mA}$		92 475	100 500	mA mA
Operation Current	$I_{\text{Q}}$	All enabled, no load, from $\text{VBUSx}$ pin Only fuel gauge enabled (active), from ISOB, no $V_{\text{VBUSx}}$ Only fuel gauge enabled (sleep), from ISOB, no $V_{\text{VBUSx}}$ <sup>1</sup> Only boost regulator enabled, all LEDs enabled, no LED current, from ISOB, no $V_{\text{VBUS}}$ Only LDO1 enabled, from ISOB, no $V_{\text{VBUSx}}$ Only LDO2 enabled, from ISOB, no $V_{\text{VBUSx}}$ Only LDO3 enabled, from ISOB, no $V_{\text{VBUSx}}$		4 160 4 2 0.8 160 160	6 230	mA $\mu\text{A}$ $\mu\text{A}$ mA $\mu\text{A}$ $\mu\text{A}$ $\mu\text{A}$
Shutdown Current	$I_{\text{STDN}}$	All disabled, from ISOB and BSNS, no $V_{\text{VBUSx}}$		0.2	2.8	$\mu\text{A}$
<b>CHARGING PARAMETERS</b>						
Fast Charge Current, Constant Current Mode	$I_{\text{CHG}}$	Programmable via I <sup>2</sup> C, battery voltage > $V_{\text{TRK\_DEAD}}$	25		650	mA
Fast Charge Current Accuracy		$I_{\text{CHG}} = 200\text{ mA}$ $T_J = 25^{\circ}\text{C}$ , $I_{\text{CHG}} = 200\text{ mA}$	180 -2.5	200	220 +2.5	mA %
Trickle Charge Current <sup>2</sup>	$I_{\text{TRK\_DEAD}}$		16	20	25	mA
Weak Charge Current	$I_{\text{CHG\_WEAK}}$	When $V_{\text{TRK\_DEAD}} < V_{\text{BSNS}} < V_{\text{WEAK}}$		$I_{\text{CHG}} + I_{\text{TRK\_DEAD}}$		mA
Dead Battery, Trickle to Weak Charge Threshold <sup>2</sup>	$V_{\text{TRK\_DEAD}}$	On BSNS	2.4	2.5	2.62	V
Weak Battery						
Weak to Fast Charge Threshold <sup>2</sup>	$V_{\text{WEAK}}$	On BSNS	2.9	3.0	3.15	V
Weak Battery Threshold Hysteresis <sup>1</sup>	$\Delta V_{\text{WEAK}}$			90		mV
Battery Termination Voltage <sup>2</sup>	$V_{\text{TRM}}$	On BSNS, $T_J = 0^{\circ}\text{C}$ to $85^{\circ}\text{C}$ On BSNS, $T_J = 25^{\circ}\text{C}$	4.158 -0.3	4.200	4.242 +0.3	V %
Battery Overvoltage Threshold	$V_{\text{BAT\_OV}}$	Relative to CFL1 voltage, BSNS rising, $V_{\text{CFL1}} = 4.0\text{ V}$	$V_{\text{CFL1}} - 0.15$			V
Charge Complete Current <sup>2</sup>	$I_{\text{END}}$	$V_{\text{BSNS}} = V_{\text{TRM}}$ , $T_J = 0^{\circ}\text{C}$ to $85^{\circ}\text{C}$	20	35	50	mA
Recharge Voltage Differential <sup>2</sup>	$V_{\text{RCH}}$	Relative to $V_{\text{TRM}}$ , BSNS falling		260		mV
Battery Node Short Threshold Voltage <sup>2</sup>	$V_{\text{BAT\_SHR}}$		2.3	2.4	2.52	V
<b>CHARGER DC-TO-DC REGULATOR</b>						
Switching Frequency	$f_{\text{SW\_CHG}}$		2.7	3	3.3	MHz
Maximum Duty Cycle <sup>3</sup>	$D_{\text{MAX}}$			96		%
Peak Inductor Current	$I_{\text{L1\_PK}}$		1500	1750	2200	mA
Regulated System Voltage	$V_{\text{ISOS\_TRK}}$	$V_{\text{BSNS}} < V_{\text{TRK\_DEAD}}$ , trickle charge mode		$V_{\text{TRM}} + 0.1$		V

Parameter	Symbol	Test Conditions/Comments	Min	Typ	Max	Unit
DC to DC Power						
PMOS On Resistance	R <sub>DSON_P</sub>			220	280	mΩ
NMOS On Resistance	R <sub>DSON_N</sub>			160	210	mΩ
SW1x Pin Leakage Current	I <sub>SW1x</sub>	V <sub>SW1x</sub> = 5.0 V			2	μA
BATTERY ISOLATION FIELD EFFECT TRANSISTOR (FET)						
LFCSP Package				202	300	mΩ
WLCSP Package				125	170	mΩ
	V <sub>ISOS_FC</sub>	V <sub>TRK_DEAD</sub> < V <sub>BSNS</sub> , fast charging constant current mode	3.15	3.3	3.45	V
Battery Supplementary Threshold	V <sub>TH_ISO</sub>	V <sub>ISOS</sub> < V <sub>ISOB</sub>	0	5	14	mV
HIGH VOLTAGE BLOCKING FET						
VBUSx Input						
High Voltage Blocking FET On Resistance	R <sub>DSON_HV</sub>	I <sub>VBUS</sub> = 100 mA, T <sub>J</sub> = 0°C to 85°C		330		mΩ
Current, Suspend Mode	I <sub>SUSPEND</sub>	EN_DCDC = low		1.45	1.8	mA
Input Voltage						
Power-Good Threshold	V <sub>VBUSOK</sub>					
Rising	V <sub>VBUSOK_RISE</sub>		3.77	3.9	4.03	V
Falling	V <sub>VBUSOK_FALL</sub>		3.47	3.6	3.73	V
Overvoltage Threshold	V <sub>VBUS_OV</sub>		5.38	5.45	5.53	V
Overvoltage Threshold Hysteresis				75		mV
THERMAL CONTROL						
Thermal Early Warning Temperature <sup>1</sup>	T <sub>SD_W</sub>			130		°C
Thermal Shutdown Temperature <sup>1</sup>	T <sub>SD</sub>	T <sub>J</sub> rising T <sub>J</sub> falling		140 110		°C °C
THERMISTOR CONTROL						
Resistance Thresholds by Battery Temperature <sup>4</sup>		R <sub>NTC</sub> = 47 kΩ, BETA_NTC = 3800, T <sub>J</sub> = 0°C to +85°C				
LFCSP Package						
Cool to Cold	R <sub>COOL_COLD</sub>		131	151.2	175	kΩ
Cold to Cool	R <sub>COLD_COOL</sub>		126	145.6	168	kΩ
Typical to Cool <sup>4</sup>	R <sub>TYP_COOL</sub>		75	86.5	99	kΩ
Cool to Typical <sup>4</sup>	R <sub>COOL_TPY</sub>		72.5	83.1	95	kΩ
Warm to Typical <sup>4</sup>	R <sub>WARM_TYP</sub>		20	23.7	27	kΩ
Typical to Warm <sup>4</sup>	R <sub>TYP_WARM</sub>		19.3	22	24.6	kΩ
Hot to Warm	R <sub>HOT_WARM</sub>		12	13.9	16	kΩ
Warm to Hot	R <sub>WARM_HOT</sub>		11	12.7	14.4	kΩ
WLCSP Package						
Cool to Cold	R <sub>COOL_COLD</sub>		140	162	185	kΩ
Cold to Cool	R <sub>COLD_COOL</sub>		133	156	180	kΩ
Typical to Cool <sup>4</sup>	R <sub>TYP_COOL</sub>		77	90	102	kΩ
Cool to Typical <sup>4</sup>	R <sub>COOL_TPY</sub>		75	86	100	kΩ
Warm to Typical <sup>4</sup>	R <sub>WARM_TYP</sub>		20	23	26	kΩ
Typical to Warm <sup>4</sup>	R <sub>TYP_WARM</sub>		18.5	21	24	kΩ
Hot to Warm	R <sub>HOT_WARM</sub>		11.5	13	15	kΩ
Warm to Hot	R <sub>WARM_HOT</sub>		10.5	12	13.5	kΩ

Parameter	Symbol	Test Conditions/Comments	Min	Typ	Max	Unit
<b>BATTERY DETECTION</b>						
Sink Current	I <sub>SINK</sub>		15	25	35	mA
Source Current	I <sub>SOURCE</sub>		7	10	13	mA
Battery Threshold						
Low	V <sub>BATL</sub>		1.8	1.9	2.0	V
High	V <sub>BATH</sub>		3.3	3.4	3.55	V
Battery Detection Timer	t <sub>BATOK</sub>			333		ms
<b>TIMERS</b>						
Start Charging Delay Timer	t <sub>START</sub>			1		sec
Trickle Charge Timer <sup>2</sup>	t <sub>TRK</sub>			60		min
Fast Charge Timer <sup>2</sup>	t <sub>CHG</sub>			600		min
Charge Complete Timer	t <sub>END</sub>	V <sub>BSNS</sub> = V <sub>TRM</sub> , I <sub>CHG</sub> < I <sub>END</sub>		7.5		min
Deglintch Timer	t <sub>DG</sub>	Applies to V <sub>TRM</sub> , V <sub>RCH</sub> , I <sub>END</sub> , V <sub>WEAK</sub> , V <sub>TRK_DEAD</sub> , V <sub>VBUSOK_FALL</sub> , and V <sub>VBUSOK_RISE</sub>		31		ms
Watchdog Timer <sup>2</sup>	t <sub>WD</sub>			32		sec
Safety Timer	t <sub>SAFE</sub>			40		min
Battery Node Short Timer <sup>2</sup>	t <sub>BAT_SHR</sub>			30		sec
<b>I<sup>2</sup>C (SCL AND SDA)</b>						
Input Voltage						
Low Level	V <sub>IL</sub>	Applies to SCL, SDA			0.5	V
High Level	V <sub>IH</sub>	Applies to SCL, SDA	1.2			V
Low Level Output Voltage	V <sub>OL</sub>	Applies to SDA, I <sub>SDA_SINK</sub> = 2 mA			0.4	V
<b>PGOOD AND BATOK</b>						
PGOOD Pin						
Leakage Current	I <sub>PGOOD_LEAK</sub>	V <sub>PGOOD</sub> = 5 V			0.5	μA
Output Low Voltage	V <sub>PGOOD_LOW</sub>	I <sub>PGOOD</sub> = 1 mA		50	100	mV
BATOK Pin						
Leakage Current	I <sub>BATOK_LEAK</sub>	V <sub>BATOK</sub> = 5 V			0.5	μA
Output Low Voltage	V <sub>BATOK_LOW</sub>	I <sub>BATOK</sub> = 1 mA		50	100	mV

<sup>1</sup> Specification is not production tested, but is supported by characterization data at initial product release.

<sup>2</sup> These values are programmable via the I<sup>2</sup>C interface. Values are given with default register values.

<sup>3</sup> Guaranteed by design.

<sup>4</sup> Typical temperature is the normal operation temperature.

## BATTERY FUEL GAUGE SPECIFICATIONS

V<sub>VIN4</sub> = V<sub>VIN123</sub> = V<sub>ISOS</sub> = 4.2 V, T<sub>J</sub> = -40°C to +125°C for minimum/maximum specifications, and T<sub>A</sub> = 25°C for typical specifications, unless otherwise noted

**Table 2.**

Parameter	Test Conditions/Comments	Min	Typ	Max	Unit
<b>BATTERY VOLTAGE MONITORING</b>					
Battery Monitor Voltage					
Range		2.7		4.5	V
Resolution	Based on 12-bit ADC		1.09		mV
Voltage Reading Accuracy	T <sub>J</sub> = 25°C	-12.5		+12.5	mV
	T <sub>J</sub> = 0°C to +85°C	-30		+30	mV

**BOOST AND LED DRIVER SPECIFICATIONS**

$V_{VIN4} = V_{VIN123} = V_{ISOS} = 3.6\text{ V}$ ,  $C9 = 4.7\ \mu\text{F}$ ,  $C10 = 4.7\ \mu\text{F}$ ,  $L2 = 4.7\ \mu\text{H}$ ,  $T_J = -40^\circ\text{C}$  to  $+125^\circ\text{C}$  for minimum/maximum specifications, and  $T_A = 25^\circ\text{C}$  for typical specifications, unless otherwise noted.

**Table 3.**

Parameter	Symbol	Test Conditions/Comments	Min	Typ	Max	Unit	
<b>INPUT CHARACTERISTICS</b>							
Input Voltage Range	$V_{VIN4}$		2.85		5.5	V	
<b>UNDERVOLTAGE LOCKOUT</b>							
	$V_{UVLO\_VIN4\_RISE}$	VIN4 rising		2.7	2.85	V	
	$V_{UVLO\_VIN4\_FALL}$	VIN4 falling	2.5	2.6		V	
<b>OUTPUT CHARACTERISTICS</b>							
Output Voltage Range	$V_{VOUT4}$	Standalone operation mode	$V_{ISOS}$		16	V	
FB4 Voltage Reference	$V_{FB4}$		0.62	0.65	0.68	V	
Line Regulation <sup>1</sup>	$\Delta V_{VOUT4}/V_{VIN4}$	$T_J = 25^\circ\text{C}$	-1.5		+1.5	%	
				0.1		%/V	
<b>POWER GOOD (PGOOD)</b>							
PGOOD Rising Threshold	$V_{PGOOD4\_RISE}$	Standalone operation mode		90		%	
PGOOD Hysteresis	$V_{PGOOD4\_HYS}$			5.5		%	
PGOOD Falling Delay	$t_{PGOOD4\_FALL}$			2		ms	
PGOOD Rising Delay	$t_{PGOOD4\_RISE}$			2		ms	
<b>SW4 CHARACTERISTICS</b>							
SW4 On Resistance	$R_{DS(on)\_NFET}$	NFET at $V_{VIN4} = 3.6\text{ V}$		460	800	m $\Omega$	
Overvoltage Threshold	$V_{OVP4}$	Boost OVP threshold = 18.5 V	17.5	18.5	19.5	V	
		Boost OVP threshold = 15 V	14.2	15	15.8	V	
		Boost OVP threshold = 10 V	9.5	10	10.5	V	
		Boost OVP threshold = 5.6 V	5.32	5.6	5.9	V	
		OVP recovery hysteresis <sup>1</sup>			5		%
Start-Up Time	$t_{SS4}$			1.0	2.7	ms	
<b>CURRENT LIMIT</b>							
	$I_{LIM4}$	BST_IPK = 0	510	600	690	mA	
		BST_IPK = 1		300		mA	
<b>OSCILLATOR CIRCUIT</b>							
Switching Frequency	$f_{SW4}$		1.35	1.5	1.65	MHz	
Minimum On Time	$t_{MIN\_ON4}$			50		ns	
<b>LED CURRENT CONTROL</b>							
LED Current	$I_{Dx}$	$I_{Dx} = 20\text{ mA}$	0		20	mA	
Range, 6-Bit				-10		+10	%
Accuracy					2.0		%
Matching					0.5	$\mu\text{A}$	
LED Pin Leakage Current	$I_{Dx\_LEAK}$					$\mu\text{A}$	
LED Current Ramp-Up Time	$t_{Dx\_RISE}$	$I_{Dx} = 20\text{ mA}$		20		$\mu\text{s}$	
LED Current Ramp-Down Time	$t_{Dx\_FALL}$	$I_{Dx} = 20\text{ mA}$		20		$\mu\text{s}$	
LED Source Headroom	$V_{Dx\_HDRM}$	ILEDx[5:0] = 11111		0.65	0.75	V	
<b>LED ON/OFF TIMER</b>							
LED Timer Accuracy		Including on timer and off timer	-10		+10	%	

<sup>1</sup> Specification is not production tested, but is supported by characterization data at initial product release.

## LDO SPECIFICATIONS

$V_{V_{BUSX}} = 5.0\text{ V}$ ,  $V_{VIN4} = V_{VIN123} = V_{ISOS} = 3.6\text{ V}$ ,  $C5 = C6 = C7 = C8 = 1\text{ }\mu\text{F}$ ;  $T_J = -40^\circ\text{C}$  to  $+125^\circ\text{C}$  for minimum/maximum specifications, and  $T_A = 25^\circ\text{C}$  for typical specifications, unless otherwise noted.

Table 4.

Parameter	Symbol	Test Conditions/Comments	Min	Typ	Max	Unit
LDO1 INPUT VOLTAGE RANGE	$V_{VIN123}$		2.56		5.5	V
KEEPALIVE LDO1						
UNDervoltage LOCKOUT	$V_{UVLO\_LDO1\_RISE}$ $V_{UVLO\_LDO1\_FALL}$ $V_{UVLO\_LDO1\_HYS}$	VIN123 rising VIN123 falling			2.56	V
Output Voltage Range	$V_{V_{OUT1}}$	Fuse trim or I <sup>2</sup> C, four bits	1.0		4.2	V
Output Accuracy		$I_{OUT1} = 10\text{ mA}$ , $T_J = 25^\circ\text{C}$	-1		+1	%
Line Regulation	$\Delta V_{V_{OUT1}}/V_{VIN123}$	$I_{OUT1} = 10\text{ mA}$ $V_{VIN123} = (V_{V_{OUT1}} + 0.5\text{ V})$ to 5.5 V	-2.0		+2.0	%/V
Load Regulation	$\Delta V_{V_{OUT1}}/I_{OUT1}$	$I_{OUT1} = 100\text{ }\mu\text{A}$ to 150 mA			0.015	%/mA
Dropout Voltage	$V_{DROp\_OUT1}$	$V_{V_{OUT1}} = 3.3\text{ V}$ , $I_{OUT1} = 10\text{ mA}$ $V_{V_{OUT1}} = 3.3\text{ V}$ , $I_{OUT1} = 150\text{ mA}$		54	130	mV
Current-Limit Threshold	$I_{LIM\_LDO1}$		200	300	440	mA
Output Noise <sup>1</sup>	$V_{NOISE\_LDO1}$	10 Hz to 100 kHz, $V_{VIN123} = 3.6\text{ V}$ , $V_{V_{OUT1}} = 3.3\text{ V}$		100		$\mu\text{V rms}$
Power Supply Rejection Ratio <sup>1</sup>	PSRR	100 Hz, $V_{VIN123} = 3.6\text{ V}$ , $V_{V_{OUT1}} = 3.3\text{ V}$ , $I_{OUT1} = 10\text{ mA}$ 1 kHz, $V_{VIN123} = 3.6\text{ V}$ , $V_{V_{OUT1}} = 3.3\text{ V}$ , $I_{OUT1} = 10\text{ mA}$		40		dB
LDO Start-Up Time	$t_{SS\_LDO1}$	$V_{V_{OUT1}} = 3.3\text{ V}$ , LDO mode		35		dB
PGOOD Rising Threshold	$V_{PGOOD1\_RISE}$	Only effective in LDO mode		600		$\mu\text{s}$
PGOOD Hysteresis	$V_{PGOOD1\_HYS}$			90		%
PGOOD Falling Delay	$t_{PGOOD1\_Fall}$			4.5		%
PGOOD Rising Delay	$t_{PGOOD1\_RISE}$			120		$\mu\text{s}$
Load Switch Turn-On Rise Time	$t_{RISE\_SWITCH1}$	$V_{OUT1} = 3.3\text{ V}$ , load switch mode		2		ms
Load Switch On Resistance	$R_{DSON\_SWITCH1}$			120		$\mu\text{s}$
C <sub>OUT</sub> Discharge Switch On Resistance	$R_{DIS\_LDO1}$	$V_{VIN123} = 3.6\text{ V}$		700		m $\Omega$
				500		$\Omega$
LDO2 INPUT VOLTAGE RANGE	$V_{VIN4}$	$V_{VIN4} = V_{VIN123}$	2.85		5.5	V
GENERAL-PURPOSE LDO2						
Undervoltage Lockout	$V_{UVLO\_LDO2\_RISE}$ $V_{UVLO\_LDO2\_FALL}$ $V_{UVLO\_LDO2\_HYS}$	VIN4 rising VIN4 falling		2.7	2.85	V
Output Voltage Range	$V_{V_{OUT2}}$	Fuse trim or I <sup>2</sup> C, 4 bits	1.0		4.2	V
Output Accuracy		$I_{OUT2} = 10\text{ mA}$ , $T_J = 25^\circ\text{C}$	-0.75		+0.75	%
Line Regulation	$(\Delta V_{V_{OUT2}})/V_{VIN123}$	$I_{OUT2} = 10\text{ mA}$ $V_{VIN123} = (V_{V_{OUT2}} + 0.5\text{ V})$ to 5.5 V	-1.5		+1.5	%
Load Regulation	$(\Delta V_{V_{OUT2}})/I_{OUT2}$	$I_{OUT2} = 100\text{ }\mu\text{A}$ to 150 mA			0.01	%/mA
Dropout Voltage						
LFCSP Package	$V_{DROp\_OUT2}$	$V_{V_{OUT2}} = 3.3\text{ V}$ , $I_{OUT2} = 10\text{ mA}$		76	140	mV
WFCSP Package	$V_{DROp\_OUT2}$	$V_{V_{OUT2}} = 3.3\text{ V}$ , $I_{OUT2} = 10\text{ mA}$		65	120	mV
LFCSP Package	$V_{DROp\_OUT2}$	$V_{V_{OUT2}} = 3.3\text{ V}$ , $I_{OUT2} = 150\text{ mA}$		100	180	mV
WFCSP Package	$V_{DROp\_OUT2}$	$V_{V_{OUT2}} = 3.3\text{ V}$ , $I_{OUT2} = 150\text{ mA}$		80	150	mV
Current-Limit Threshold	$I_{LIM\_LDO2}$		220	320	430	mA

Parameter	Symbol	Test Conditions/Comments	Min	Typ	Max	Unit
Output Noise <sup>1</sup>	V <sub>NOISE_LDO2</sub>	10 Hz to 100 kHz, V <sub>VIN123</sub> = 3.6 V, V <sub>VOUT2</sub> = 3.3 V		120		μV rms
Power Supply Rejection Ratio <sup>1</sup>	PSRR	100 Hz, V <sub>VIN123</sub> = 3.6 V, V <sub>VOUT2</sub> = 3.3 V, I <sub>OUT2</sub> = 10 mA		60		dB
		1 kHz, V <sub>VIN123</sub> = 3.6 V, V <sub>VOUT2</sub> = 3.3 V, I <sub>OUT2</sub> = 10 mA		50		dB
LDO Start-Up Time	t <sub>SS_LDO2</sub>	V <sub>VOUT2</sub> = 3.3 V, LDO mode		80		μs
Load Switch Turn-On Rise Time	t <sub>RISE_SWITCH2</sub>	V <sub>VOUT2</sub> = 3.3 V, load switch mode		80		μs
Load Switch On Resistance						
LFCSP Package	R <sub>DSON_SWITCH2</sub>			400	600	mΩ
WFCSP Package	R <sub>DSON_SWITCH2</sub>			300	500	mΩ
C <sub>OUT</sub> Discharge Switch On Resistance	R <sub>DIS_LDO2</sub>	V <sub>VIN123</sub> = 3.6 V		500		Ω
LDO3 INPUT VOLTAGE RANGE	V <sub>VIN4</sub>	V <sub>VIN4</sub> = V <sub>VIN123</sub>	2.85		5.5	V
GENERAL-PURPOSE LDO3						
UNDERVOLTAGE LOCKOUT						
V <sub>UVLO_LDO3_RISE</sub>	V <sub>UVLO_LDO3_RISE</sub>	VIN4 rising		2.7	2.85	V
V <sub>UVLO_LDO3_FALL</sub>	V <sub>UVLO_LDO3_FALL</sub>	VIN4 falling	2.5	2.6		V
V <sub>UVLO_LDO3_HYS</sub>	V <sub>UVLO_LDO3_HYS</sub>			100		mV
Output Voltage Range	V <sub>VOUT3</sub>	Fuse trim or I <sup>2</sup> C, four bits	1.0		4.2	V
Output Accuracy	V <sub>VOUT3</sub>	I <sub>OUT3</sub> = 10 mA, T <sub>J</sub> = +25°C	-0.75		+0.75	%
		I <sub>OUT3</sub> = 10 mA	-1.5		+1.5	%
Line Regulation	ΔV <sub>OUT3</sub> /V <sub>VIN123</sub>	V <sub>VIN123</sub> = (V <sub>VOUT3</sub> + 0.5 V) to 5.5 V	-0.1		+0.1	%/V
Load Regulation	ΔV <sub>OUT3</sub> /I <sub>OUT3</sub>	I <sub>OUT3</sub> = 100 μA to 150 mA			0.01	%/mA
Dropout Voltage						
LFCSP Package	V <sub>DROP_OUT3</sub>	V <sub>VOUT3</sub> = 3.3 V, I <sub>OUT3</sub> = 10 mA		76	140	mV
WFCSP Package	V <sub>DROP_OUT3</sub>	V <sub>VOUT3</sub> = 3.3 V, I <sub>OUT3</sub> = 10 mA		65	120	mV
LFCSP Package	V <sub>DROP_OUT3</sub>	V <sub>VOUT3</sub> = 3.3 V, I <sub>OUT3</sub> = 150 mA		100	180	mV
WFCSP Package	V <sub>DROP_OUT3</sub>	V <sub>VOUT3</sub> = 3.3 V, I <sub>OUT3</sub> = 150 mA		80	150	mV
Current Limit Threshold	I <sub>LIM_LDO3</sub>		220	320	430	mA
Output Noise <sup>1</sup>	V <sub>NOISE_LDO3</sub>	10 Hz to 100 kHz, V <sub>VIN123</sub> = 3.6 V, V <sub>VOUT3</sub> = 3.3 V		120		μV rms
Power Supply Rejection Ratio <sup>1</sup>	PSRR	100 Hz, V <sub>VIN123</sub> = 3.6 V, V <sub>VOUT3</sub> = 3.3 V, I <sub>OUT3</sub> = 10 mA		60		dB
		1 kHz, V <sub>VIN123</sub> = 3.6 V, V <sub>VOUT3</sub> = 3.3 V, I <sub>OUT3</sub> = 10 mA		50		dB
LDO Start-Up Time	t <sub>SS_LDO3</sub>	V <sub>VOUT3</sub> = 3.3 V, LDO mode		80		μs
Load Switch Turn-On Rise Time	t <sub>RISE_SWITCH3</sub>	V <sub>VOUT3</sub> = 3.3 V, load switch mode		80		μs
Load Switch On Resistance						
LFCSP Package	R <sub>DSON_SWITCH3</sub>			400	600	mΩ
WFCSP Package	R <sub>DSON_SWITCH3</sub>			300	500	mΩ
C <sub>OUT</sub> Discharge Switch On Resistance	R <sub>DIS_LDO3</sub>	V <sub>VIN123</sub> = 3.6 V		500		Ω

<sup>1</sup> Guaranteed by design.

**RECOMMENDED INPUT AND OUTPUT CAPACITANCE AND INDUCTANCE SPECIFICATIONS**

Table 5.

Parameter	Min	Typ	Max	Unit
<b>EFFECTIVE CAPACITANCE</b>				
Charger Capacitance				
VBUSx Pin	1.0	2.2		μF
CFL1 Pin	2.0	4.7		μF
CFL2 Pin	1.0	2.2		μF
ISOS Pin	4.0	10		μF
ISOB Pin	4.0	10		μF
LDO Capacitance				
VIN123 Pin	0.7	1		μF
LDO1	0.7	1		μF
LDO2	0.7	1		μF
LDO3	0.7	1		μF
Boost Capacitance				
VIN4 Pin	1	4.7		μF
VOUT4 Pin	0.47	4.7		μF
<b>INDUCTANCE</b>				
Buck	0.5	1.5	2.2	μH
Boost	2	4.7	10	μH

I<sup>2</sup>C-COMPATIBLE INTERFACE TIMING SPECIFICATIONS

Table 6.

Parameter	Symbol	Min	Typ	Max	Unit
I <sup>2</sup> C-COMPATIBLE INTERFACE					
Capacitive Load, Each Bus Line	C <sub>S</sub>			400	pF
SCL					
Clock Frequency	f <sub>SCL</sub>			400	kHz
High Time	t <sub>HIGH</sub>	0.6			μs
Low Time	t <sub>LOW</sub>	1.3			μs
Data					
Setup Time	t <sub>SU,DAT</sub>	100			ns
Hold Time <sup>1</sup>	t <sub>HD,DAT</sub>	0		0.9	μs
Setup Time for Repeated Start	t <sub>SU,STA</sub>	0.6			μs
Hold Time for Start/Repeated Start	t <sub>HD,STA</sub>	0.6			μs
Bus Free Time Between a Stop and a Start Condition	t <sub>BUF</sub>	1.3			μs
Setup Time for Stop Condition	t <sub>SU,STO</sub>	0.6			μs
SCL/SDA					
Rise Time	t <sub>R</sub>			300	ns
Fall Time	t <sub>F</sub>			300	ns
Pulse Width of Suppressed Spike	t <sub>SP</sub>	0		50	ns

<sup>1</sup> A master device must provide a hold time of at least 300 ns for the SDA signal to bridge the undefined region of the falling edge of SCL. See Figure 3, the I<sup>2</sup>C timing diagram.

Timing Diagram

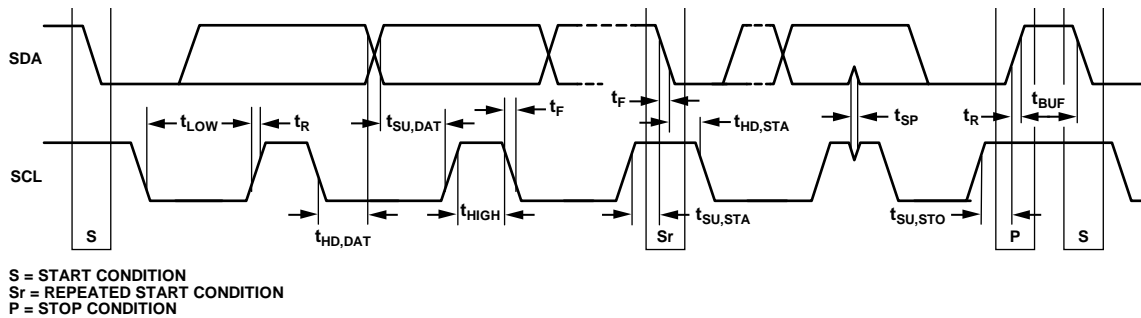

Figure 3. I<sup>2</sup>C Timing Diagram

14797-002

## ABSOLUTE MAXIMUM RATINGS

Table 7.

Parameter	Rating
VBUSA, VBUSB to PGND1	–0.5 V to +20 V
SW4, VOUT4, D1, D2, D3, D4, D5 to PGND4	–0.5 V to +20 V
FB4	–0.3 V to +6 V
CFL2 to AGND	–0.3 V to +3.3 V
PGND1, PGND4 to AGND	–0.3 V to +0.3 V
All Other Pins to AGND	–0.3 V to +6 V
Continuous Drain Current, Battery Supplementary Mode, from ISOB to ISOS, $T_J = 125^\circ\text{C}$	1.1 A
Storage Temperature Range	–65°C to +150°C
Operating Junction Temperature Range	–40°C to +125°C
Soldering Conditions	JEDEC J-STD-020

Stresses at or above those listed under Absolute Maximum Ratings may cause permanent damage to the product. This is a stress rating only; functional operation of the product at these or any other conditions above those indicated in the operational section of this specification is not implied. Operation beyond the maximum operating conditions for extended periods may affect product reliability.

## THERMAL RESISTANCE

Thermal performance is directly linked to printed circuit board (PCB) design and operating environment.

Careful attention to PCB thermal design is required.  $\theta_{JA}$  is the natural convection junction to ambient thermal resistance measured in a one cubic foot sealed enclosure.  $\theta_{JC}$  is the junction to case thermal resistance.

Table 8. Thermal Resistance

Package Type	$\theta_{JA}$	$\theta_{JC}$	Unit
CP-32-12 <sup>1</sup>	42	2.1	°C/W
CB-32-1	64	0.7	°C/W

<sup>1</sup> Thermal impedance simulated values are based on a JEDEC 2S2P thermal test board with nine thermal vias. See JEDEC JESD51.

## Maximum Power Dissipation

The maximum safe power dissipation in the [ADP5350](#) package is limited by the associated rise in junction temperature ( $T_J$ ) on the die. At approximately 150°C, which is the glass transition temperature, the plastic changes its properties. Even temporarily exceeding this temperature limit may change the stresses that the package exerts on the die, permanently shifting the parametric performance of the [ADP5350](#). Exceeding a junction temperature of 175°C for an extended period of time can result in changes in the silicon devices that potentially cause failure.

## ESD CAUTION



**ESD (electrostatic discharge) sensitive device.** Charged devices and circuit boards can discharge without detection. Although this product features patented or proprietary protection circuitry, damage may occur on devices subjected to high energy ESD. Therefore, proper ESD precautions should be taken to avoid performance degradation or loss of functionality.

## PIN CONFIGURATION AND FUNCTION DESCRIPTIONS

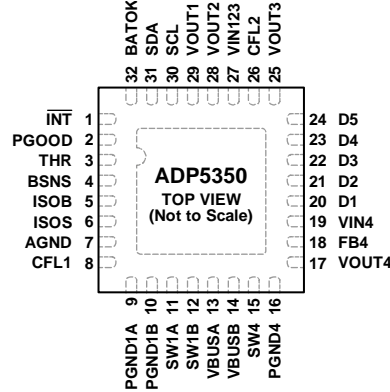

NOTES  
 1. EXPOSED PAD (ANALOG GROUND). THE EXPOSED PAD MUST BE CONNECTED AND SOLDERED TO AN EXTERNAL GROUND PLANE.

14797-003

Figure 4. LFCSP Pin Configuration (Top View)

Table 9. LFCSP Pin Function Descriptions

Pin No.	Mnemonic	Description
1	INT	Processor Interrupt (Active Low). This pin requires an external pull-up resistor. If this pin is not used, it can be left floating.
2	PGOOD	Power-Good Signal Output. This open-drain output is the power-good signal for the selected channels.
3	THR	Battery Pack Thermistor Connection.
4	BSNS	Battery Voltage Sense Pin.
5	ISOB	Battery Supply Side Input to Internal Isolation FET/Battery Current Regulation FET.
6	ISOS	Charger Supply Side Input to Internal Isolation FET/Battery Current Regulation FET.
7	AGND	Analog Ground.
8	CFL1	Power input to the charger regulator. Connect a ceramic filter capacitor between this pin and either PGND1A or PGND1B.
9, 10	PGND1A, PGND1B	Power Ground for the Battery Charger.
11, 12	SW1A, SW1B	Switching Node for the Battery Charger.
13, 14	VBUSA, VBUSB	Power Connection to USB Bus Voltage.
15	SW4	Switching Node for the Boost Regulator.
16	PGND4	Power Ground for the Boost Regulator.
17	VOUT4	Power Output for the Boost Regulator.
18	FB4	Feedback Sensing Input for the Boost Regulator. In standalone mode, connect this pin to a resistor divider from $V_{VOUT4}$ . In LED operation mode, connect FB4 to ground.
19	VIN4	Input Voltage for the Boost Regulator and LDO Control Block.
20	D1	LED 1 Sink Channel. Connect this pin to the cathode of the LED.
21	D2	LED 2 Sink Channel. Connect this pin to the cathode of the LED.
22	D3	LED 3 Sink Channel. Connect this pin to the cathode of the LED.
23	D4	LED 4 Sink Channel. Connect this pin to the cathode of the LED.
24	D5	LED 5 Sink Channel. Connect this pin to the cathode of the LED.
25	VOUT3	Power Output for LDO3.
26	CFL2	Internal Regulator Output for the Fuel Gauge. Connect a ceramic capacitor between this pin and AGND.
27	VIN123	Power Input for LDO1, LDO2, and LDO3.
28	VOUT2	Power Output for LDO2.
29	VOUT1	Power Output for LDO1.
30	SCL	I <sup>2</sup> C Serial Clock. This pin requires an external pull-up resistor.
31	SDA	I <sup>2</sup> C Serial Data. This pin requires an external pull-up resistor.
32	BATOK	Battery Status Open-Drain Output Flag (Active High). This pin enables the system when the battery reaches $V_{WEAK}$ .
	EPAD	Exposed Pad (Analog Ground). The exposed pad must be connected and soldered to an external ground plane.

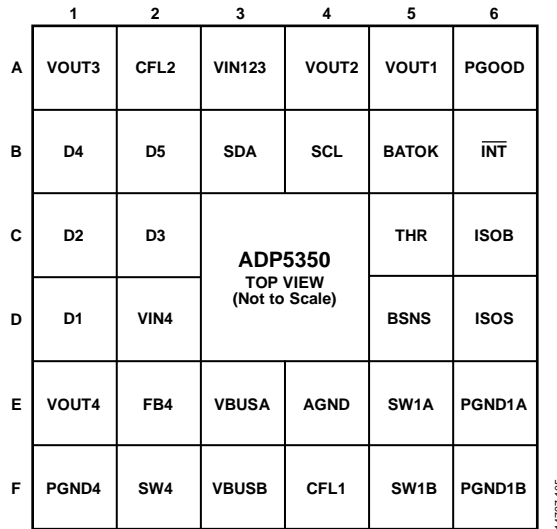

Figure 5. WLCSP Pin Configuration (Top View)

Table 10. WLCSP Pin Function Descriptions

Pin No.	Mnemonic	Description
B6	INT	Processor Interrupt (Active Low). This pin requires an external pull-up resistor. If this pin is not used, it can be left floating.
A6	PGOOD	Power-Good Signal Output. This open-drain output is the power-good signal for the selected channels.
C5	THR	Battery Pack Thermistor Connection.
D5	BSNS	Battery Voltage Sense Pin.
C6	ISOB	Battery Supply Side Input to Internal Isolation FET/Battery Current Regulation FET.
D6	ISOS	Charger Supply Side Input to Internal Isolation FET/Battery Current Regulation FET.
E4	AGND	Analog Ground.
F4	CFL1	Power input to the charger regulator. Connect a ceramic filter capacitor between this pin and either PGND1A or PGND1B.
E6, F6	PGND1A, PGND1B	Power Ground for the Battery Charger.
E5, F5	SW1A, SW1B	Switching Node for the Battery Charger.
E3, F3	VBUSA, VBUSB	Power Connection to USB Bus Voltage.
F2	SW4	Switching Node for the Boost Regulator.
F1	PGND4	Power Ground for the Boost Regulator.
E1	VOUT4	Power Output for the Boost Regulator.
E2	FB4	Feedback Sensing Input for the Boost Regulator. In standalone mode, connect this pin to a resistor divider from $V_{VOUT4}$ . In LED operation mode, connect FB4 to ground.
D2	VIN4	Input Voltage for the Boost Regulator and LDO Control Block.
D1	D1	LED 1 Sink Channel. Connect this pin to the cathode of the LED.
C1	D2	LED 2 Sink Channel. Connect this pin to the cathode of the LED.
C2	D3	LED 3 Sink Channel. Connect this pin to the cathode of the LED.
B1	D4	LED 4 Sink Channel. Connect this pin to the cathode of the LED.
B2	D5	LED 5 Sink Channel. Connect this pin to the cathode of the LED.
A1	VOUT3	Power Output for LDO3.
A2	CFL2	Internal Regulator Output for the Fuel Gauge. Connect a ceramic capacitor between this pin and AGND.
A3	VIN123	Power Input for LDO1, LDO2, and LDO3.
A4	VOUT2	Power Output for LDO2.
A5	VOUT1	Power Output for LDO1.
B4	SCL	I <sup>2</sup> C Serial Clock. This pin requires an external pull-up resistor.
B3	SDA	I <sup>2</sup> C Serial Data. This pin requires an external pull-up resistor.
B5	BATOK	Battery Status Open-Drain Output Flag (Active High). This pin enables the system when the battery reaches $V_{WEAK}$ .

### TYPICAL PERFORMANCE CHARACTERISTICS

$V_{VBUSx} = 5.0\text{ V}$ ,  $V_{VIN4} = V_{VIN123} = V_{ISOS} = 3.6\text{ V}$ ,  $C_{BUS} = 2.2\text{ }\mu\text{F}$ ,  $C_3 = 10\text{ }\mu\text{F}$ ,  $C_4 = 10\text{ }\mu\text{F}$ ,  $C_{CFL1} = 4.7\text{ }\mu\text{F}$ ,  $L_{OUT1} = 1.5\text{ }\mu\text{H}$ , all registers are at default values, unless otherwise noted.

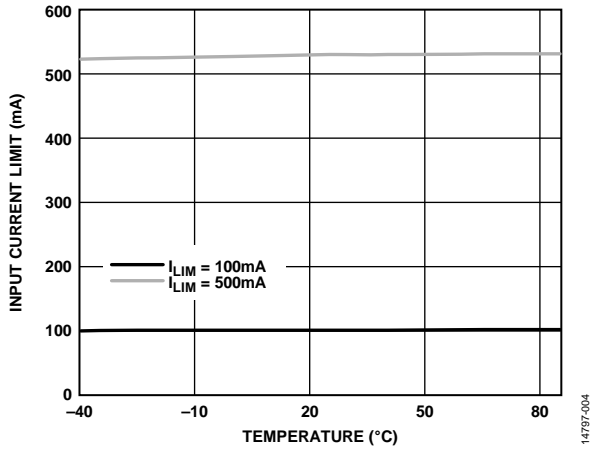

Figure 6. Input Current Limit vs. Temperature

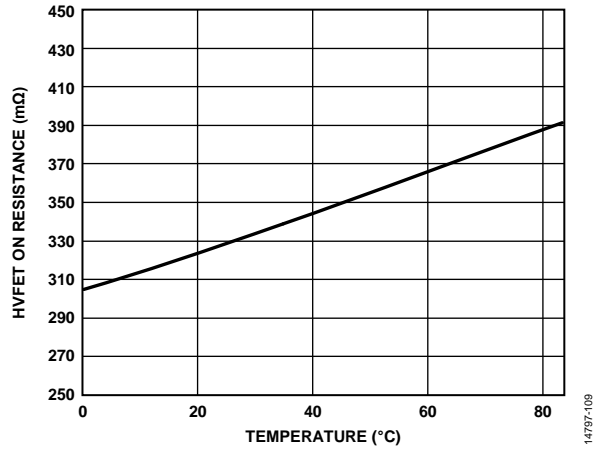

Figure 9. High Voltage FET (HV FET) On Resistance vs. Temperature

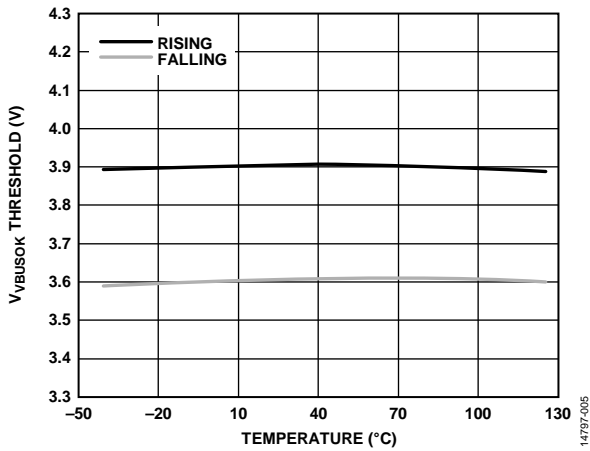

Figure 7. V\_VBUSOK Threshold vs. Temperature

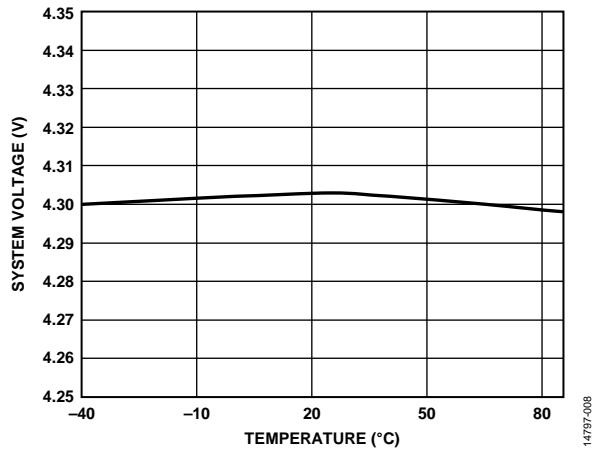

Figure 10. System Voltage vs. Temperature

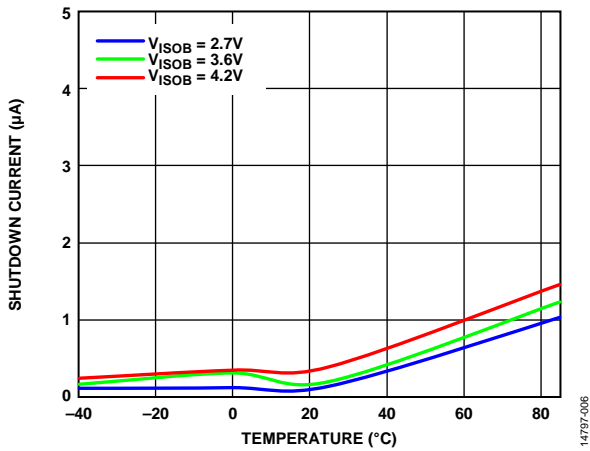

Figure 8. Shutdown Current vs. Temperature

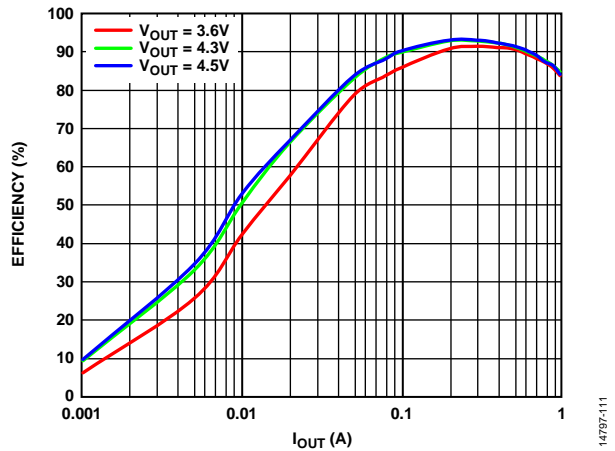

Figure 11. Efficiency vs. Output Current (I<sub>OUT</sub>), Buck Regulator Efficiency

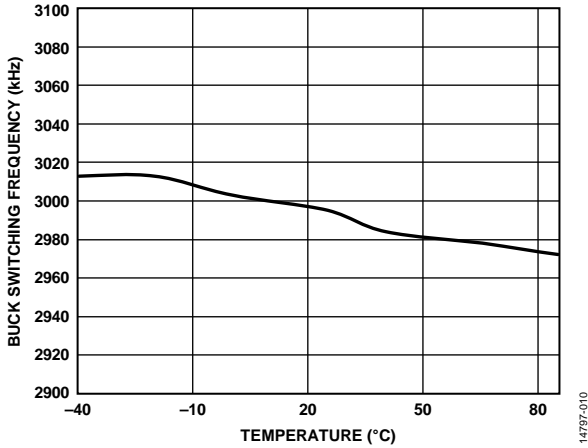

Figure 12. Buck Switching Frequency vs. Temperature

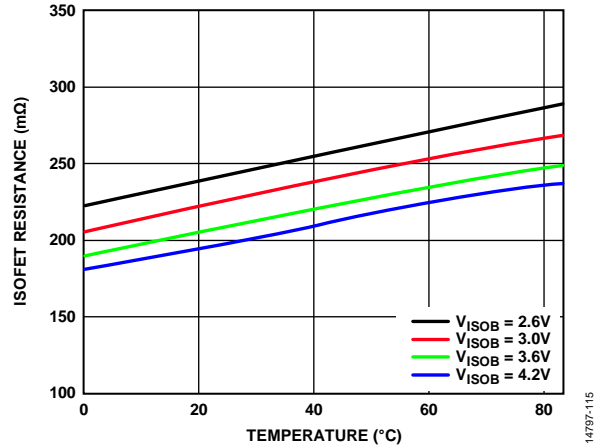

Figure 15. Isolation FET (ISO FET) Resistance vs. Temperature at Various Battery Voltage Levels, LFCSP Package

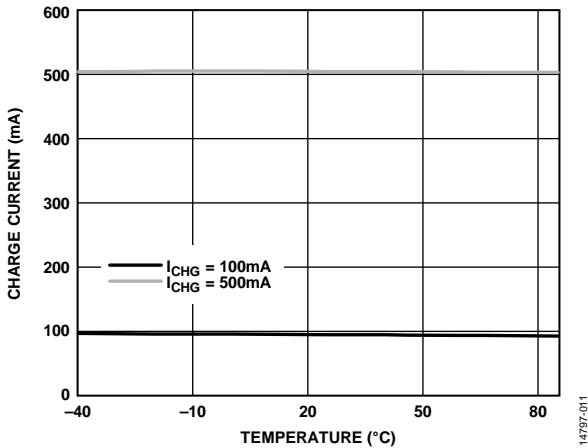

Figure 13. Charge Current vs. Temperature

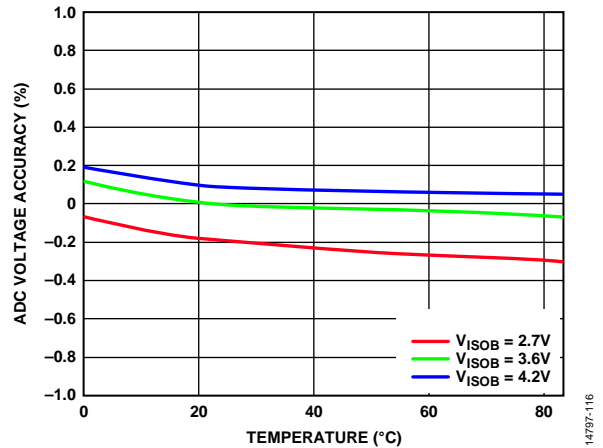

Figure 16. ADC Voltage Accuracy vs. Temperature

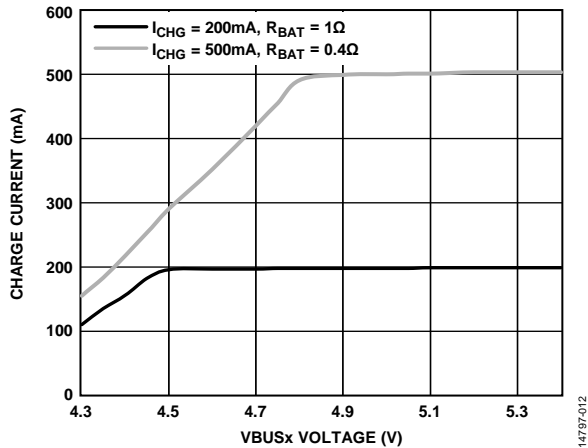

Figure 14. Charge Current vs. VBUSx Voltage

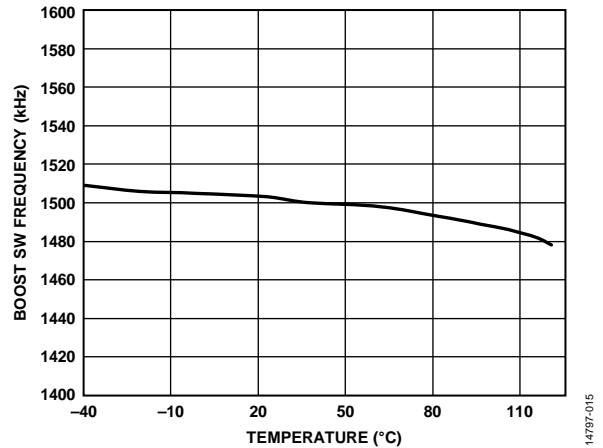

Figure 17. Boost Switching Frequency vs. Temperature

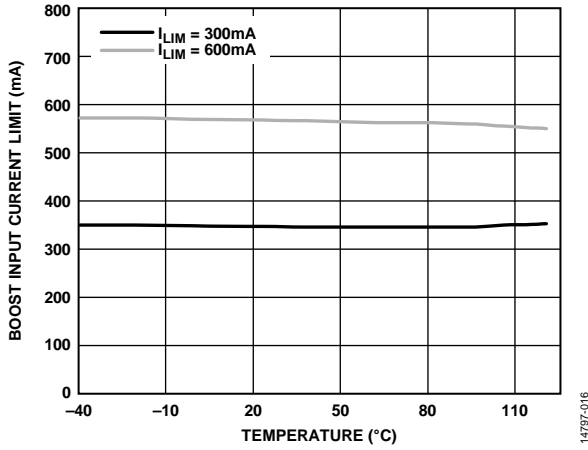

Figure 18. Boost Input Current Limit vs. Temperature

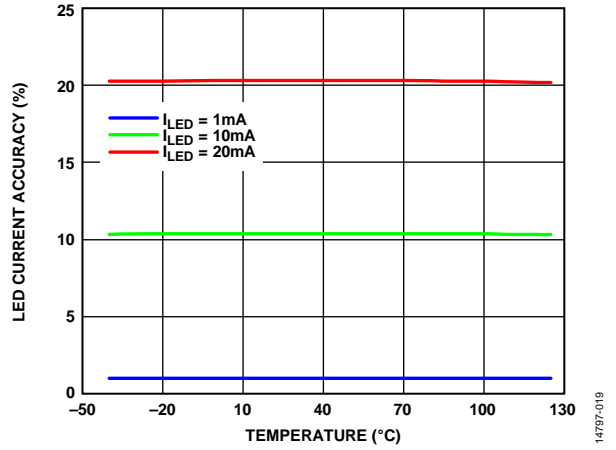

Figure 21. LED Current Accuracy vs. Temperature

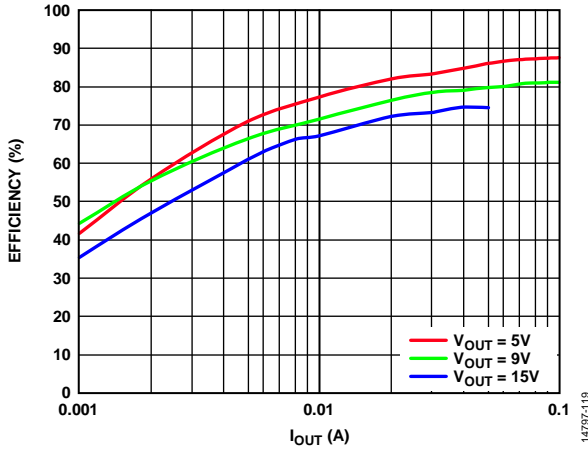

Figure 19. Boost Efficiency vs. Output Current ( $I_{OUT}$ )

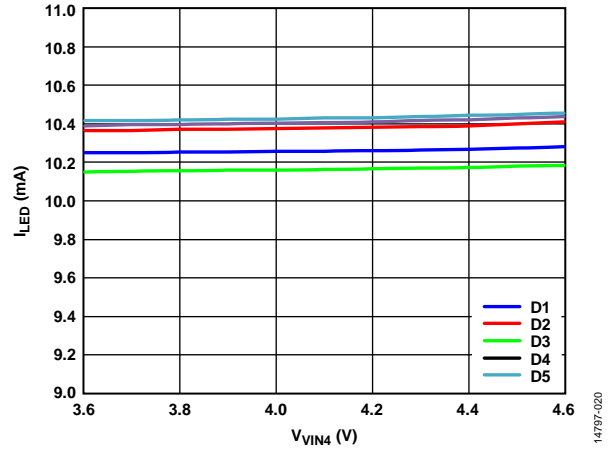

Figure 22. LED Channel Current ( $I_{LED}$ ) vs.  $V_{IN4}$

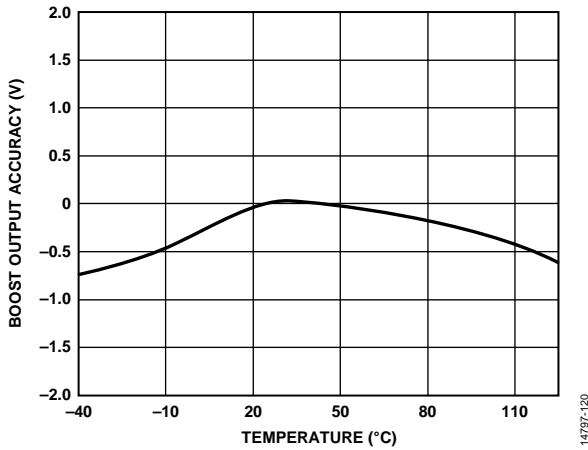

Figure 20. Boost Output Accuracy vs. Temperature,  $V_{OUT4} = 5 V$

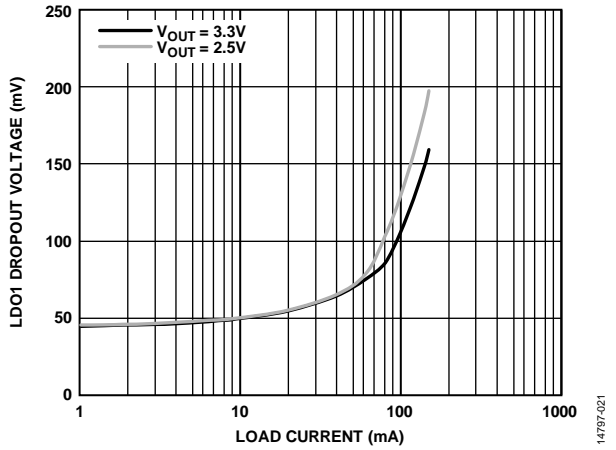

Figure 23. LDO1 Dropout Voltage vs. Load Current, LFCSP Package

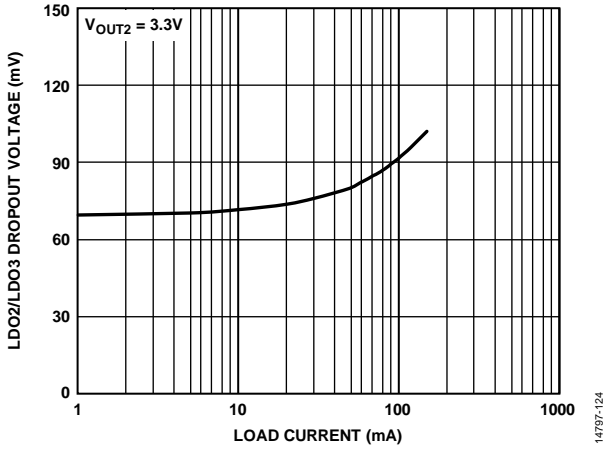

Figure 24. LDO2/LDO3 Dropout Voltage vs. Load Current, LFCSP Package

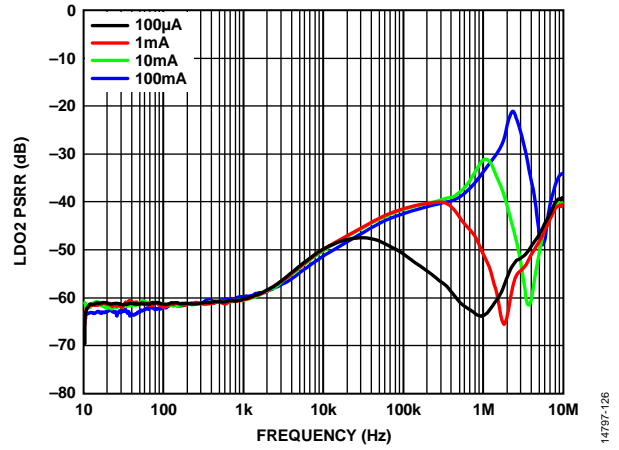

Figure 26. LDO2 Power Supply Rejection Ratio (PSRR) vs. Frequency,  $V_{OUT2} = 3.3\text{ V}$ ,  $V_{IN123} = 3.6\text{ V}$

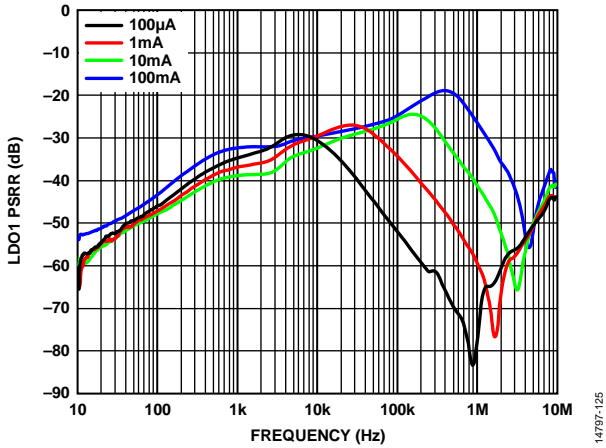

Figure 25. LDO1 PSRR vs. Frequency,  $V_{OUT1} = 3.3\text{ V}$ ,  $V_{IN123} = 3.6\text{ V}$

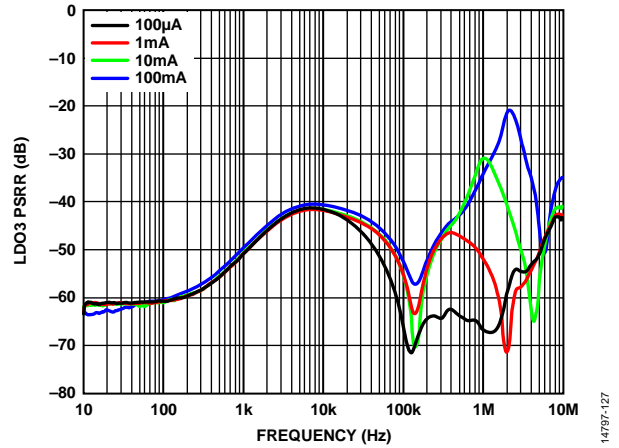

Figure 27. LDO3 PSRR vs. Frequency,  $V_{OUT3} = 3.3\text{ V}$ ,  $V_{IN123} = 3.6\text{ V}$

TYPICAL WAVEFORMS

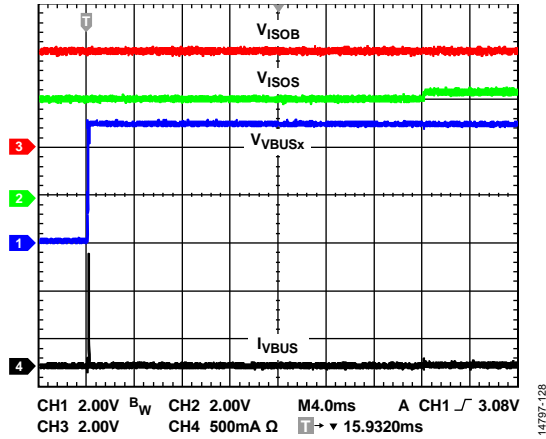

Figure 28. VBUSx Connected to USB Power

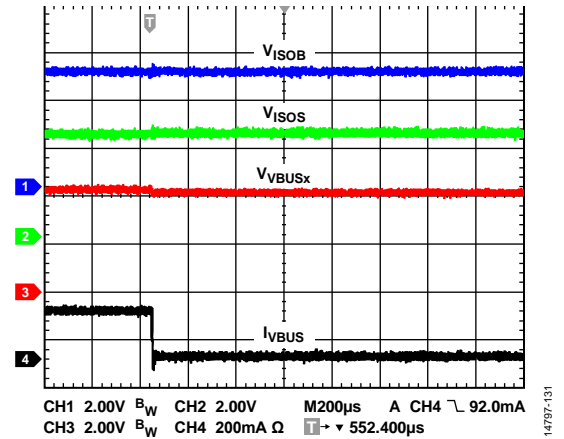

Figure 31. Charger Stop with EN\_CHG Set Low,  $I_{LIM} = 500\text{ mA}$ ,  $I_{CHG} = 200\text{ mA}$ ,  $V_{VBUSx} = 5\text{ V}$

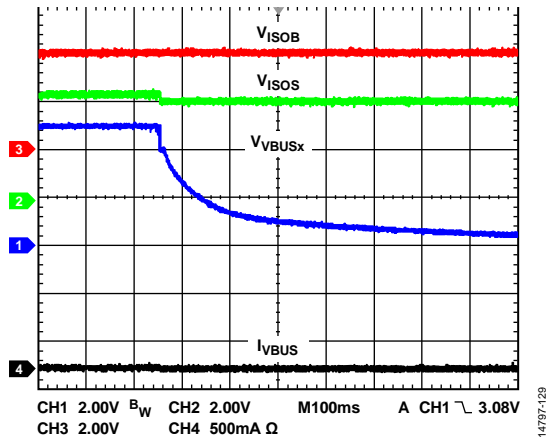

Figure 29. VBUSx Disconnected from USB Power

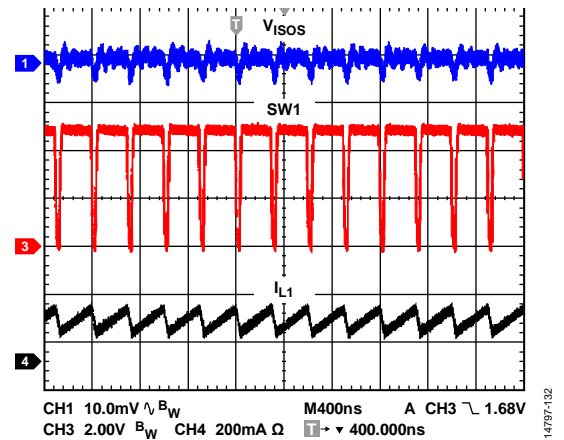

Figure 32. Fast Charger Status,  $I_{CHG} = 200\text{ mA}$ ,  $V_{VBUSx} = 5\text{ V}$

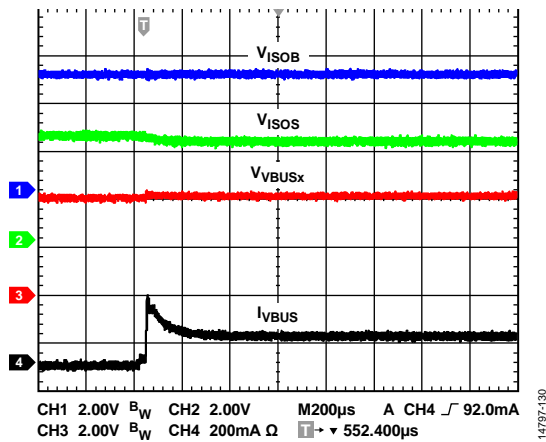

Figure 30. Charger Start with EN\_CHG Set High,  $I_{LIM} = 500\text{ mA}$ ,  $I_{CHG} = 150\text{ mA}$ ,  $V_{VBUSx} = 5\text{ V}$

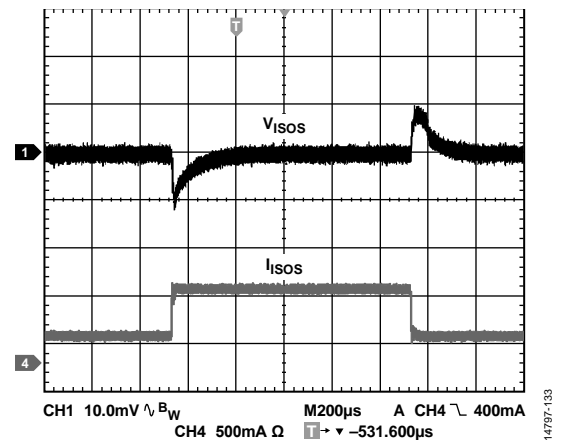

Figure 33.  $V_{ISOS}$  Voltage Load Transient Response,  $V_{ISOS} = 4.3\text{ V}$ ,  $V_{VBUSx} = 5\text{ V}$

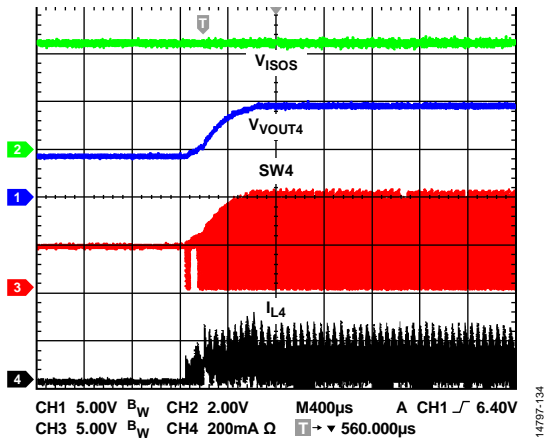

Figure 34. Boost Voltage Soft Start, LED Mode;  $I_{LED1} = I_{LED2} = I_{LED3} = 10$  mA

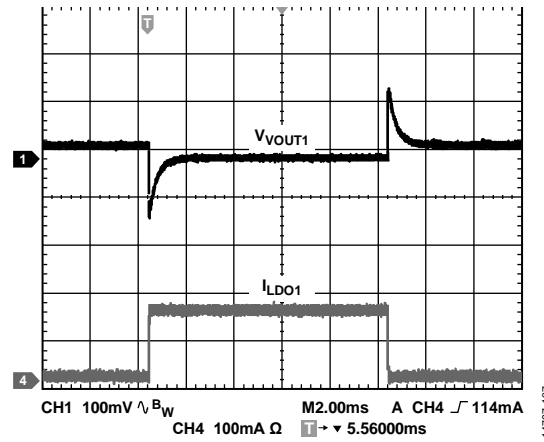

Figure 37. LDO1 Output Load Transient Response

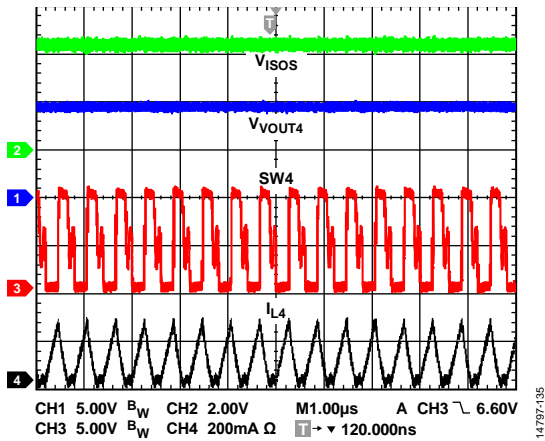

Figure 35. Boost Operation, LED Mode;  $I_{LED1} = I_{LED2} = I_{LED3} = 10$  mA

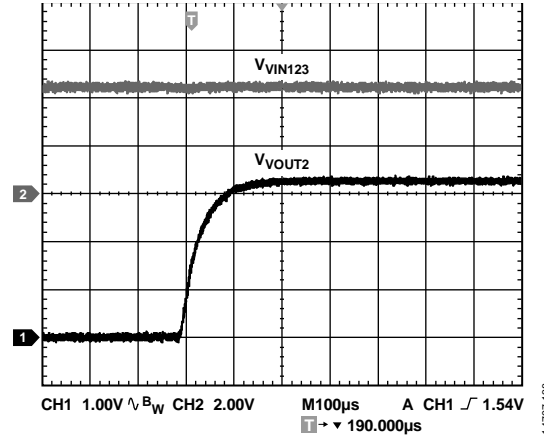

Figure 38. LDO2 Output Soft Start,  $R_{LDO1} = 330$   $\Omega$

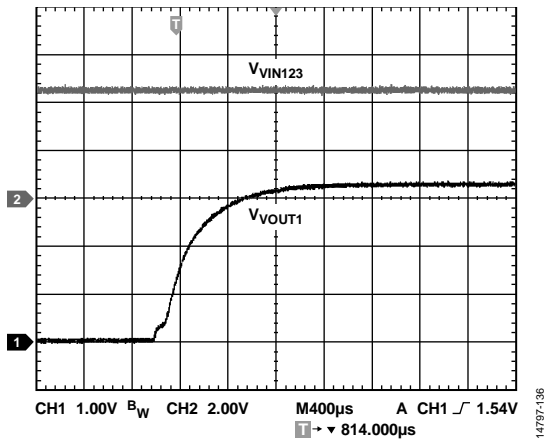

Figure 36. LDO1 Output Soft Start,  $R_{LDO1} = 330$   $\Omega$

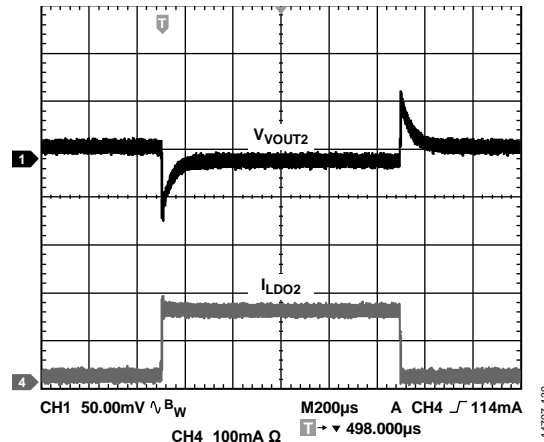

Figure 39. LDO2 Output Load Transient Response

## THEORY OF OPERATION

### BATTERY CHARGER OVERVIEW

The ADP5350 integrates a fully I<sup>2</sup>C-programmable charger for single-cell Li-Ion or Li-Ion polymer batteries suitable for a wide range of portable applications.

Figure 40 shows the complete charge cycle of the ADP5350 when VBUSx is connected. The ISOS pin voltage remains at  $V_{ISOS\_TRK}$  when the device is not charging or when it is in trickle charge mode. When the device begins a fast charge, the  $V_{ISOS}$  voltage follows the battery voltage until the charge is complete. The charge current keeps constant in CC mode and reduces to  $I_{END}$  in CV mode. When the battery voltage,  $V_{ISOB}$ , drops to  $V_{TRM} - V_{RCH}$ , the charger resumes to charge until the charge completes.

The highly efficient switch dc-to-dc architecture enables higher charging currents as well as a lower temperature charging operation that results in faster charging times.

The charger of the ADP5350 operates from an input voltage from 4 V to 5.4 V but is tolerant of voltages of up to 20 V. This tolerance alleviates concerns about USB bus spiking during disconnection or connection.

The ADP5350 features an internal FET between the dc-to-dc charger output and the battery. This FET permits battery isolation and, therefore, system powering in a dead battery or no battery scenario, which allows immediate system function upon connection to a USB power supply.

The charger of the ADP5350 is fully compliant with the USB 3.0 specification and enables charging via the mini USB VBUSx pin from a wall charger, car charger, or USB host port. Based on the type of USB source, which is detected by an external USB detection device, the ADP5350 can be set to apply the correct current limit for optimal charging and USB compliance. The USB charger permits correct operation under all USB compliant sources, such as wall chargers, host chargers, hub chargers, and standard hosts and hubs.

A processor is able to control the USB charger using the I<sup>2</sup>C to program the charging current and numerous other parameters, including

- Trickle charge current level and voltage threshold
- Fast charge (CC) current level
- Fast charge (CV) voltage level
- Fast charge safety timer period
- Watchdog safety timer parameters
- Weak battery threshold detection
- End of charge current level for charge complete
- Recharge threshold
- VBUSx input current limit
- Charge enable and disable

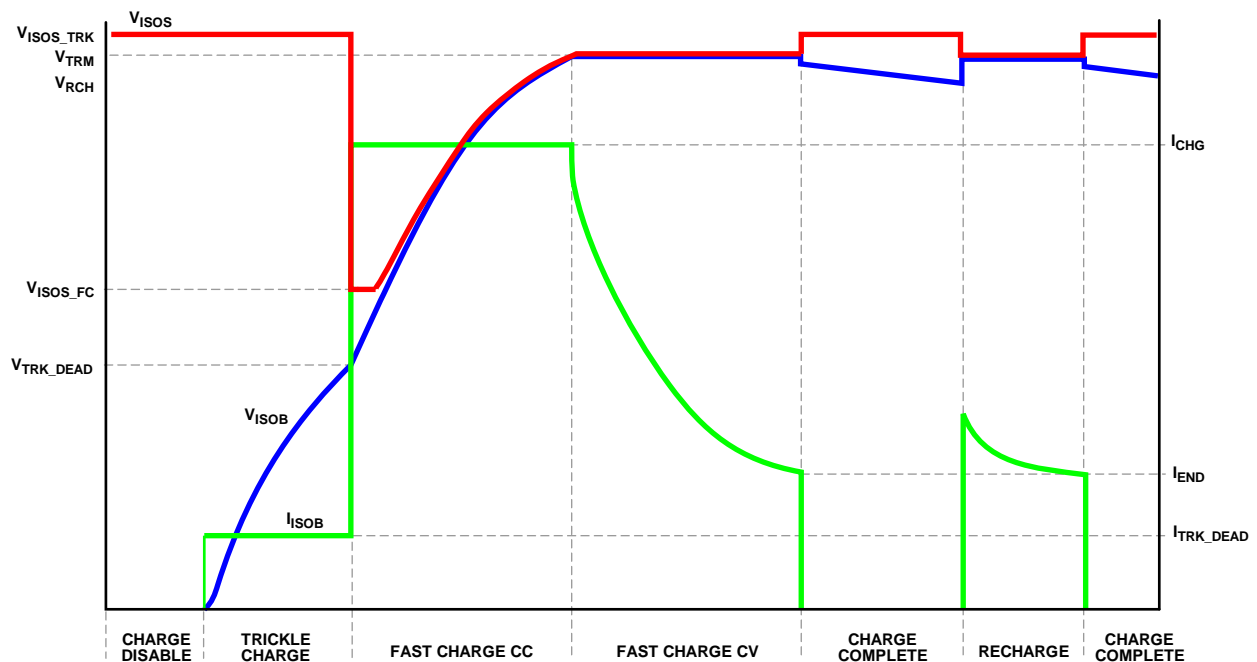

Figure 40. ADP5350 Battery Charging Profile

14797-023

## CHARGER MODES

### Input Current Limit

The [ADP5350](#) features a programmable input current limit, from 100 mA to 1500 mA, via the ILIM[3:0] I<sup>2</sup>C bits, which ensures compatibility with the USB limits requirements listed in Table 11. The current limit defaults to 100 mA to allow compatibility with a USB host or hub that is not configured. This input current limit resets to the 100 mA default value during every power cycle on VBUSx to protect the USB port.

When the input current limit feature is used, the available input current may be too low for the charger to meet the programmed charging current, I<sub>CHG</sub>, and the rate of charge is reduced. In this case, the VBUS\_ILIM flag is set.

When connecting an improper voltage level to VBUSx, the dc-to-dc regulator shuts down, the ISOFET turns on, and the high voltage blocking part is in a state wherein it draws only 1.3 mA (typical) of current until V<sub>VBUSx</sub> reaches the V<sub>VBUS\_OV\_FALL</sub> level.

The [ADP5350](#) always monitors the V<sub>VBUSx</sub> voltage when there is a proper USB power connection. The VBUSOK bit, Bit 3 in Register 0x36, indicates whether the V<sub>VBUSx</sub> voltage is within V<sub>VBUS\_OV</sub> and V<sub>VBUSOK</sub>, which can be programmed to be masked to the PGOOD pin via the VBUSOK\_MASK bit in Register 0x37.

The default setting of the VBUSOK\_MASK is programmed via a factory fuse trim.

### Trickle Charge Mode

A deeply discharged Li-Ion cell may exhibit a very low cell voltage, making it unsafe to charge the cell at high current rates. The [ADP5350](#) charger uses a trickle charge mode to reset the battery pack protection circuit and lift the cell voltage to a safe level for fast charging. A cell with a voltage below V<sub>TRK\_DEAD</sub> is charged with the trickle mode current, I<sub>TRK\_DEAD</sub>. During trickle charge mode, the CHARGER\_STATUS[3:0] bits are set.

During trickle charging, the ISOS node is regulated to V<sub>ISOS\_TRK</sub> by the dc-to-dc regulator and the battery isolation FET is off, which means the battery is isolated from the system power supply.

The enable of the trickle charging function is controlled via the I<sup>2</sup>C EN\_TRK bit.

### Trickle Charge Mode Timer

The duration of trickle charge mode is monitored to ensure the battery is revived from its deeply discharged state. If trickle charge mode runs for longer than 60 minutes without the cell voltage reaching V<sub>TRK\_DEAD</sub>, a fault condition is assumed and the charging stops. The battery isolation FET turns on and the dc-to-dc regulator stops working. The fault condition is asserted in the CHARGER\_STATUS register, allowing the user to initiate the fault recovery procedure specified in the Fault Recovery section.

### Weak Charge Mode (Constant Current)

When the battery voltage exceeds V<sub>TRK\_DEAD</sub> but is less than V<sub>WEAK</sub>, the charger switches to weak charge mode and the ISOS node is regulated to V<sub>ISOS\_FC</sub> by turning on the battery isolation FET.

In weak charge mode, the battery charges with the programmed I<sub>CHG</sub> current from the ISOS node through the isolation FET and trickle charge current, I<sub>TRK\_DEAD</sub>. Due to the VBUSx input current limit, the real I<sub>CHG</sub> charge current from the ISOS node may be less than the programmed value. The system load can also share the current from the ISOS node. However, the trickle charge current, I<sub>TRK\_DEAD</sub>, remains on to charge the battery in weak charge mode.

### Fast Charge Mode (Constant Current)

When the battery voltage exceeds V<sub>TRK\_DEAD</sub> and V<sub>WEAK</sub>, the charger switches to fast charge mode, charging the battery with the constant current, I<sub>CHG</sub>. During fast charge mode (CC), the CHARGER\_STATUS[3:0] bits are set.

During CC mode, other features may prevent the current, I<sub>CHG</sub>, from reaching its full programmed value. Isothermal charging mode or input current limiting for USB compatibility may affect the value of I<sub>CHG</sub> under certain operating conditions. The voltage on ISOS is regulated to stay at V<sub>ISOS\_FC</sub> by the battery isolation FET when V<sub>ISOB</sub> < V<sub>ISOS\_FC</sub>.

### Fast Charge Mode (Constant Voltage)

As the battery charges, its voltage rises and approaches the termination voltage, V<sub>TRM</sub>. The [ADP5350](#) charger monitors the voltage on the BSNS pin to determine when charging ends. However, the internal ESR of the battery pack combined with PCB and other parasitic series resistances creates a voltage drop between the sense point at the BSNS pin and the cell terminal itself. To compensate for this and ensure a fully charged cell, the [ADP5350](#) enters a constant voltage charge mode when the BSNS voltage reaches the termination voltage. The [ADP5350](#) reduces charge current gradually as the cell continues to charge, maintaining a voltage of V<sub>TRM</sub> on the BSNS pin. During fast charge mode (constant voltage), the CHARGER\_STATUS[3:0] bits are set.

### Fast Charge Mode Timer

The duration of fast charge mode is monitored to ensure that the battery is charging correctly. If the fast charge mode runs for longer than t<sub>CHG</sub> without the voltage at the BSNS pin reaching V<sub>TRM</sub>, a fault condition is assumed and charging stops. The battery isolation FET remains on, and the dc-to-dc regulator shuts down. The fault condition is asserted on the CHARGER\_STATUS register, allowing the user to initiate the fault recovery procedure specified in the Fault Recovery section.

If the fast charge mode runs for longer than t<sub>CHG</sub>, and V<sub>TRM</sub> is reached on the BSNS pin but the charge current is not yet below I<sub>END</sub>, charging stops by turning the battery isolation FET off, but the system voltage is maintained at V<sub>ISOS\_TRK</sub> by the dc-to-dc regulator. No fault condition is asserted in this circumstance, and the [ADP5350](#) transitions to charge complete status.

Table 11. Input Current Compatibility with Standard USB Limits

Mode	Standard USB Limit	ADP5350 Function
USB 2.0	100 mA limit for standard USB host or hub 500 mA limit for standard USB host or hub	100 mA input current limit or I <sup>2</sup> C programmed value 500 mA input current limit or I <sup>2</sup> C programmed value
USB 3.0	150 mA limit for super speed USB 3.0 host or hub 900 mA limit for super speed, high speed USB host or hub charger	150 mA input current limit or I <sup>2</sup> C programmed value 900 mA input current limit or I <sup>2</sup> C programmed value
Dedicated Charger	1500 mA limit for dedicated charger or low/full speed USB host or hub charger	1500 mA input current limit or I <sup>2</sup> C programmed value

### Watchdog Timer

The ADP5350 charger features a programmable watchdog timer function to ensure charging is under the control of the processor. The watchdog timer starts running when the ADP5350 charger determines that the processor is operational, that is, when the processor sets the RESET\_WD bit for the first time or when the battery voltage is greater than the weak battery threshold,  $V_{WEAK}$ . When the watchdog timer triggers, it must be reset regularly within the watchdog timer period,  $t_{WD}$ .

If the watchdog timer expires without being reset while in charger mode, the ADP5350 charger assumes there is a software problem and triggers the safety timer,  $t_{SAFE}$ . For more information, see the Safety Timer section. Meanwhile, the  $I_{LIM}$  current limit resets to the default value.

### Safety Timer

If the watchdog timer (see the Watchdog Timer section for more information) expires while in charger mode, the ADP5350 charger initiates the safety timer,  $t_{SAFE}$ . Charging continues for a period of  $t_{SAFE}$ , and then stops. The battery isolation FET remains on while the dc-to-dc regulator shuts down. The CHARGER\_STATUS[3:0] bits are then set. Resetting the charger requires VBUSx to be powered down and powered up.

### Charge Complete

The ADP5350 charger monitors the charging current while in CV fast charge mode. If the current falls below  $I_{END}$  and remains below  $I_{END}$  for  $t_{END}$ , the charger is stopped by turning the battery isolation FET off, but the system voltage is maintained at  $V_{ISOS\_TRK}$  by the dc-to-dc regulator and the CHDONE flag is set. If the charging current falls below  $I_{END}$  for less than  $t_{END}$  and then rises above  $I_{END}$  again, the  $t_{END}$  timer resets.

### Recharge

After the detection of a complete charge, and the isolated FET turns off, the ADP5350 charger continues to monitor the BSNS pin. If the BSNS pin voltage falls below  $V_{TRM} - V_{RCH}$ , the charger reactivates charging. Under most circumstances, triggering the recharge threshold results in the charger entering fast charge constant current mode.

### Battery Charging Enable/Disable

The ADP5350 charging function can be disabled by setting the I<sup>2</sup>C EN\_CHG bit to low. If the I<sup>2</sup>C EN\_CHG bit is low, the dc-to-dc regulator is still on and regulates the ISOS voltage to

$V_{ISOS\_TRK}$ , the battery isolation FET turns off, and the dc-to-dc regulator provides the power for the system.

### BATTERY ISOLATION FET

The ADP5350 charger features an integrated battery isolation FET for power path control. The battery isolation FET isolates a deeply discharged Li-Ion cell from the system power supply in trickle charge mode and when charging is complete, thereby allowing the system to be powered from the VBUSx node.

When the  $V_{VBUSx}$  voltage is below  $V_{VBUSOK\_FALL}$ , the battery isolation FET is in full conduction mode.

The battery isolation FET is off during trickle charge mode. When the battery voltage exceeds  $V_{TRK\_DEAD}$ , the battery isolation FET switches to the system voltage regulation mode and the battery isolation FET maintains the  $V_{ISOS\_FC}$  voltage on the ISOS pin. When the battery voltage exceeds  $V_{ISOS\_FC}$ , the battery isolation FET is in full conduction mode.

The battery isolation FET supplements the battery to support high current functions on the system power supply.

When the voltage on ISOS drops below ISOB, the battery isolation FET enters full conduction mode.

When the voltage on ISOS rises above ISOB, the isolation FET enters regulating mode or full conduction mode, depending on the Li-Ion cell voltage and the dc-to-dc charger mode.

### BATTERY DETECTION

#### Battery Level Detection

The ADP5350 charger features a battery detection mechanism to detect an absent battery. The charger actively sinks and sources current into the ISOB/BSNS node when the enable charger and  $V_{VBUSx}$  have reached the  $V_{VBUSOK\_RISE}$  level, and voltage vs. time is detected. The sink phase is used to detect a charged battery, whereas the source phase is used to detect a discharged battery.

The sink phase (see Figure 41) sinks  $I_{SINK}$  current from the ISOB and BSNS pin for a time,  $t_{BATOK}$ . If the BSNS pin is below  $V_{BATL}$  when the  $t_{BATOK}$  timer expires, the charger assumes no battery is present or battery is shorted, and starts the source phase. If the BSNS exceeds the  $V_{BATL}$  voltage when the  $t_{BATOK}$  timer expires, the charger assumes the battery is present and begins a new charge cycle.

The source phase sources  $I_{SOURCE}$  current to ISOB or the BSNS pin for a time,  $t_{BATOK}$ . If the BSNS pin exceeds  $V_{BATH}$  before the

$t_{BATOK}$  timer expires, the charger assumes that no battery is present. If the BSNS does not exceed the  $V_{BATH}$  voltage when the  $t_{BATOK}$  timer expires, the charger assumes that a battery is present, and begins a new charge cycle.

When the ADP5350 battery monitor is enabled and detects that the battery voltage is higher than  $V_{WEAK}$ , Bit 2 in Register 0x36, BATOK, asserts high. The PGOOD pin can be programmed to mask BATOK, which indicates whether the battery voltage is higher than  $V_{WEAK}$ .

**Battery (ISOB) Short Detection**

A battery short occurs under a damaged battery condition or when the battery protection circuitry is enabled.

After a source phase, if the voltage on ISOB or BSNS remains below  $V_{BATH}$ , either the battery voltage is low or the battery node is shorted. When the battery voltage is low, trickle charge mode is initiated (see Figure 42). If the voltage on BSNS remains below  $V_{BAT\_SHR}$  after  $t_{BAT\_SHR}$  has elapsed, the ADP5350 assumes that the battery node is shorted. A fault is declared on Register 0x0A, Bit 3.

The trickle charge branch is active during the battery short scenario, and trickle charge current to the battery is maintained until the 60 minutes of the trickle charge mode timer expires.

**BATTERY TEMPERATURE**

**Battery Pack Thermistor Input**

The ADP5350 charger features battery pack temperature sensing that precludes charging when the battery pack temperature is outside the specified range. The THR pin provides an on and off switching current source, which must be connected directly to the battery pack thermistor,  $R_{NTC}$ . The activation interval of the THR current source is 167 ms.

The battery pack temperature sensing can be controlled by I<sup>2</sup>C using the conditions shown in Table 12. Note that the I<sup>2</sup>C register default setting for EN\_THR (Register 0x07) is 0 = temperature sensing off.

**Table 12. THR Input Function**

Conditions		THR Function
VBUSx	V <sub>ISOB</sub>	
Open or V <sub>BUS</sub> = 0 V to 4.0 V	<2.5 V	Off
Open or V <sub>BUS</sub> = 0 V to 4.0 V	>2.5 V	Controlled by I <sup>2</sup> C
V <sub>BUS</sub> = 4.0 V to 5.5 V	Don't care	Always on

If the battery pack thermistor is not connected directly to the ADP5350 THR pin, connect a 47 kΩ (tolerance ±20%) dummy resistor between THR and AGND. Leaving the THR pin open results in a false detection of the battery temperature of <0°C and charging being disabled. Alternatively, select the temperature source from the I<sup>2</sup>C interface by setting Register 0x20, Bit 6.

The ADP5350 charger suspends charging if the battery temperature is outside the range of less than 0°C or greater than 60°C. For temperatures greater than 0°C, and likewise for temperatures lower than 60°C, the THR\_STATUS[2:0] bits are set accordingly. The ISOFET remains on while the dc-to-dc regulator shuts down.

The ADP5350 charger is designed for use with a negative temperature coefficient (NTC) thermistor in the battery pack with a nominal resistance value of 47 kΩ, 10 kΩ, or 100 kΩ at 25°C, which is selected via the I<sup>2</sup>C interface in Register 0x0C, Bit 4, and Register 0x3D, Bit 0. The temperature coefficient curve (beta) of  $R_{NTC}$  also can be fuse selected in the ADP5350.

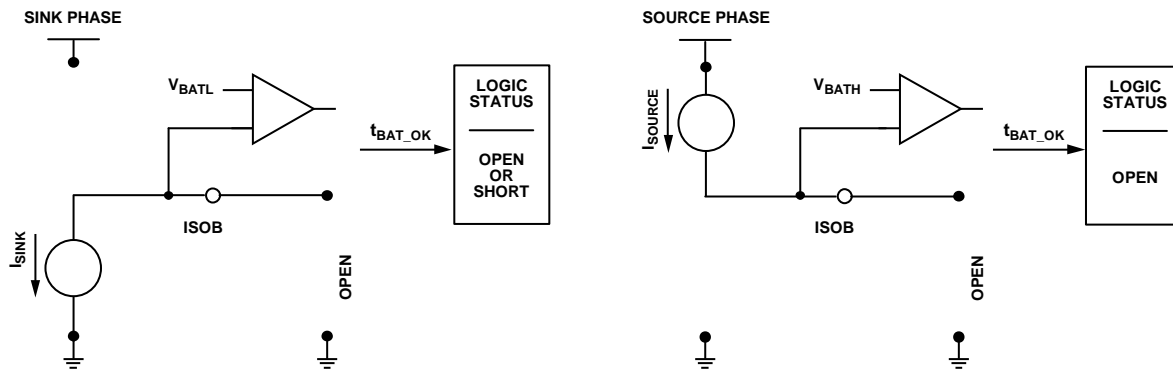

Figure 41. Battery Detection Sequence

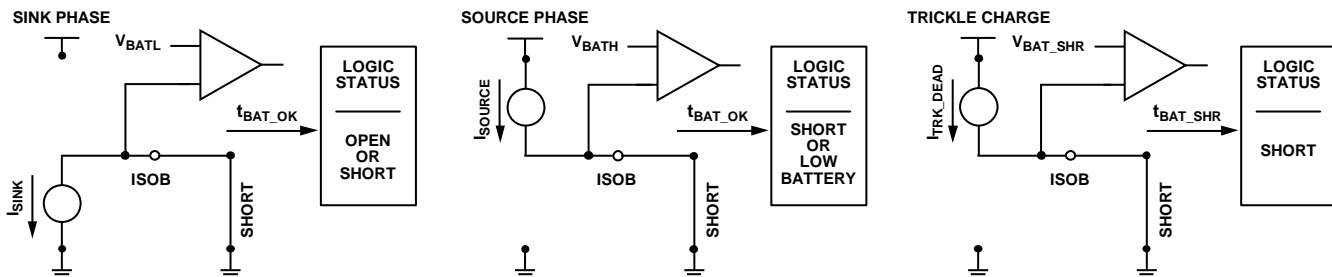

Figure 42. Battery Short Detection Sequence

**Battery Temperature from I<sup>2</sup>C**

If a microcontroller has another accuracy temperature sense in system, it can select the temperature source via the I<sup>2</sup>C setting and write the temperature value to the BAT\_TEMP[5:0] bits. The I<sup>2</sup>C source battery temperature range is between –2°C and +61°C.

**JEITA Li-Ion Battery Temperature Charging Specification**

The charge of the ADP5350 is compliant with the JEITA Li-Ion battery charging temperature specifications, as shown in Table 14.

The JEITA function is enabled via the I<sup>2</sup>C interface. When the ADP5350 detects a JEITA cool condition, charging current is reduced according to Table 13.

When the ADP5350 identifies a hot or cold battery condition, the battery isolation FET turns on and the dc-to-dc regulator shuts down. In this condition, the battery provides the V<sub>ISOS</sub> supply.

**Table 13. JEITA Cool Temperature Limit—Reduced Charge Current Levels**

ICHG[3:0]	I <sub>CHG</sub> JEITA (mA)	
	ILIM_JEITA_COOL = 0	ILIM_JEITA_COOL = 1
0000 = 25 mA	25	25
0001 = 50 mA	25	25
0010 = 75 mA	25	25
0011 = 100 mA	50	25
0100 = 125 mA	50	25
0101 = 150 mA	75	25
0110 = 200 mA	100	25
0111 = 250 mA	125	25
1000 = 300 mA	150	50
1001 = 350 mA	175	50
1010 = 400 mA	200	50
1011 = 450 mA	225	50
1100 = 500 mA	250	50
1101 = 550 mA	275	50
1110 = 600 mA	300	50
1111 = 650 mA	325	50

**Table 14. JEITA Default Li-Ion Battery Charging Specifications**

Parameter	Symbol	Conditions	Min	Max	Unit
JEITA Cold Temperature Limits	T <sub>JEITA_COLD</sub>	No battery charging occurs.		0	°C
JEITA Cool Temperature Limits	T <sub>JEITA_COOL</sub>	Battery charging occurs at approximately 50% or 10% of programmed level. See Table 13 for specific charging current reduction levels.	0	10	°C
JEITA Typical Temperature Limits	T <sub>JEITA_TYP</sub>	Normal battery charging occurs at default/programmed levels.	10	45	°C
JEITA Warm Temperature Limits	T <sub>JEITA_WARM</sub>	Battery termination voltage (V <sub>TRM</sub> ) is reduced by 100 mV from the programmed value.	45	60	°C
JEITA Hot Temperature Limits	T <sub>JEITA_HOT</sub>	No battery charging occurs.	60		°C

BATTERY CHARGER OPERATIONAL FLOWCHART

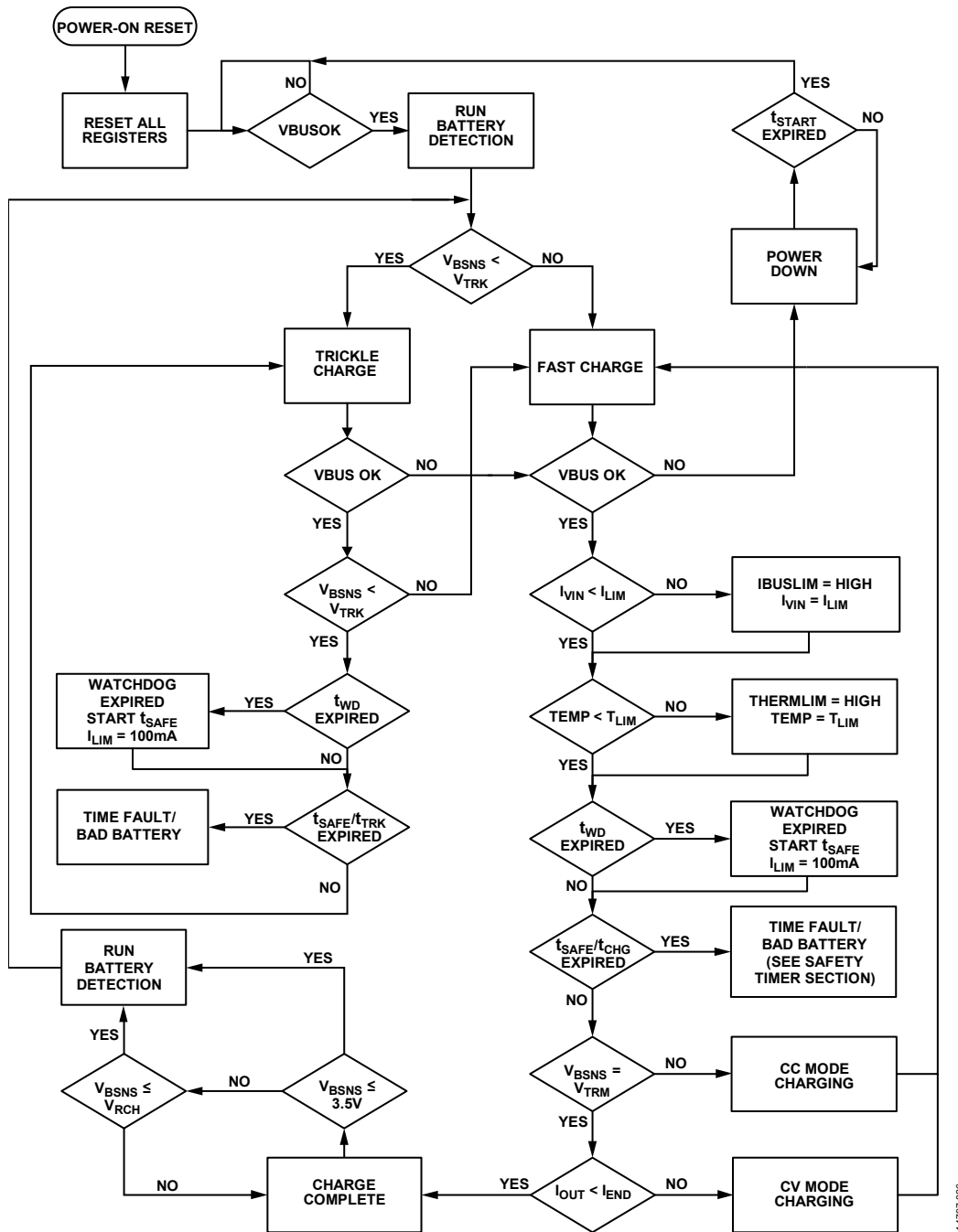

Figure 43. ADP5350 Charger Operational Flowchart

BATTERY VOLTAGE-BASED FUEL GAUGE

Overview

The ADP5350 Li-Ion battery fuel gauge is based on the voltage measurement with a 12-bit ADC. SOC is calculated with a battery model integrated in the ADP5350. Ten voltage values based on the battery characterization and the battery internal resistance at different temperatures must be written to the V\_SOC\_x register and RBAT\_x register of the ADP5350 for SOC calculation.

Operation Mode

The ADP5350 fuel gauge, in shut down mode by default, provides extremely low standby current consumption from the battery. After the fuel gauge function is enabled, two operation modes can be selected: active mode and sleep mode. The fuel gauge operation mode is controlled by the I<sup>2</sup>C.

In active mode, the battery SOC is updated every 1 sec by the sensed battery voltage, which achieves better accuracy and indicates the remaining battery capacity but consumes 160 μA

(typical) of operation current. In sleep mode, the battery SOC is updated every 5 min and the battery instant current ( $I_{INS}$ ) is updated every 37.5 sec, which reduces the current to typically 4  $\mu A$  (see Table 15). The ADP5350 automatically switches from sleep mode to active mode when the current through the isolation FET is higher than typically 35 mA. The system current must be less than 35 mA when switching to sleep mode. Depending on the system load, the mode can be switched to active mode to achieve better SOC accuracy.

Table 15. Fuel Gauge Operation Mode

Operation Mode	Current (Typical)	ADC Sample Rate	SOC Update Rate
Shutdown	0.2 $\mu A$	None	None
Sleep	4 $\mu A$	37.5 sec	5 min
Active	160 $\mu A$	0.125 sec	1 sec

**Battery Voltage Compensation**

The battery internal resistance impacts the accuracy of a traditional voltage-based SOC. A higher load current translates to a higher voltage drop ( $\Delta V_{DROP}$ ) over the internal resistance,  $R_{BAT}$  (see Figure 44).

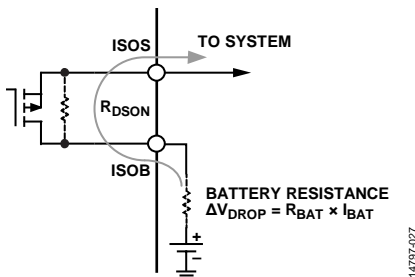

Figure 44. Discharge Current Sensing Through Battery Isolation FET

The ADP5350 uses the battery isolation FET for battery discharge current sensing. The device senses the ISOS and ISOB node voltages to obtain the delta voltage. Divide the delta voltage by  $R_{DSON}$  to achieve the discharge current, which can be used for SOC calculation compensation.

The voltage reading from the BSNS pin is compensated using the following equation and can be read in the VBAT\_READ\_H and VBAT\_READ\_L registers.

$$V_{BAT} = V_{BSNS} + R_{BAT} \times I_{BAT}$$

where:

$V_{BSNS}$  is the voltage on the BSNS pin.

$R_{BAT}$  is the internal resistance of the battery.

$I_{BAT}$  is the current through the battery.

When the battery is charging,  $I_{BAT}$  is the charging current.

During the battery discharges,  $I_{BAT}$  is calculated by the voltage sense on the isolated FET.

The internal resistance of the battery has strong temperature dependency. Figure 45 shows the internal resistance temperature coefficient using a 280 mAh, 3.7 V Li-Ion cell battery.

The ADP5350 contains I<sup>2</sup>C registers to calculate the  $R_{BAT}$  value, where the user can program the battery internal resistance characterized from the battery at certain temperatures. The ADP5350 uses this data to calculate the battery internal resistance at different temperatures.

It is strongly recommended to use the I<sup>2</sup>C bits, BAT\_TEMP, to obtain an accurate battery temperature if the system has such temperature sense information. If using the ADP5350 internal sense circuitry as the temperature source, only four temperature levels for battery resistance compensation are available, which may cause errors in the SOC calculation relating to the battery resistance temperature coefficient.

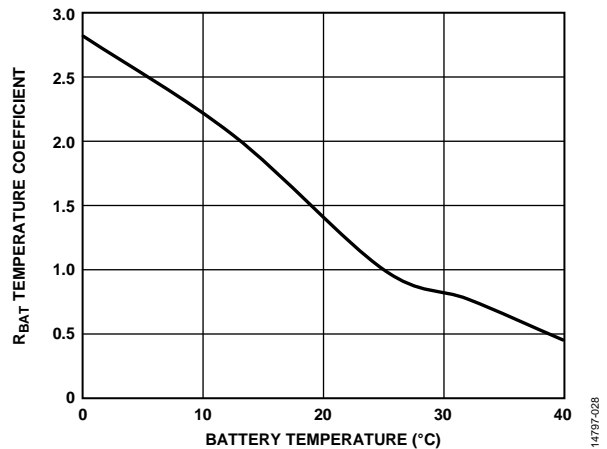

Figure 45.  $R_{BAT}$  Temperature Coefficient vs. Battery Temperature, Temperature Coefficient of the Li-Ion Battery, Relative to Battery  $R_{BAT}$  at 25°C

In addition, the internal resistance of the battery has a remaining capacity dependency, especially when the SOC is less than 20%. The ADP5350 allows the user to program different internal resistance coefficients when the SOC is in the 20% to 0% range during a discharge by programming the corresponding bits, K\_RBAT\_SOC (see Figure 46).

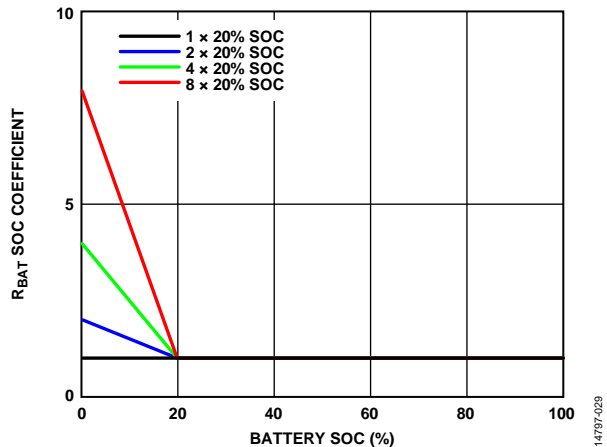

Figure 46.  $R_{BAT}$  SOC Coefficient vs. Battery SOC, SOC Coefficient of the Li-Ion Battery, Relative to Battery  $R_{BAT}$  at 25°C

For some batteries, the internal resistance is different when the battery is in charge vs. discharge mode. Use the  $K_{RBAT\_CHARGE}$  bits to program the battery internal resistance coefficient when charging.

**State of Charge Limit Filter**

To avoid impacting SOC accuracy caused by the effects of a battery discharge and the instantaneous interference on the battery current sense, the ADP5350 uses filter limitation for delta SOC calculation of each step. The filter limitation can be selected from a 0.125 C rate to a 3 C rate via I<sup>2</sup>C programming, which is equal to or greater than a real system current consumption (the C rate is the battery charge or discharge current rate over the battery capacity). For example, when the full system load is 60 mA with 300 mAh, and the discharge current rate is 0.2 C, the filter limitation can be programmed to 0.25 C using the  $FILTER\_DISCHARGE$  bits.

When the fuel gauge is enabled, the SOC value is reset based on the current battery voltage and internal resistor compensation, without any initial filter effects. Repeatedly disabling and enabling the fuel gauge or setting Register 0x25, Bit 7 to reset the SOC value during a battery discharge increases errors in SOC calculation. It is recommended that the SOC be reset only when there is no discharge current and the battery voltage is in a completely relaxed state; that is, the battery voltage is stable.

During sleep mode, the filter limitation is reduced because the ADP5350 outputs a low discharge current.

**FLOWCHART OF SOC CALCULATION**

See Figure 47 for a flowchart of the SOC calculation.  $Down\_Lim$  is the delta SOC in each step when the SOC reduces.  $Up\_Lim$  is the delta SOC in each step when the SOC increases.

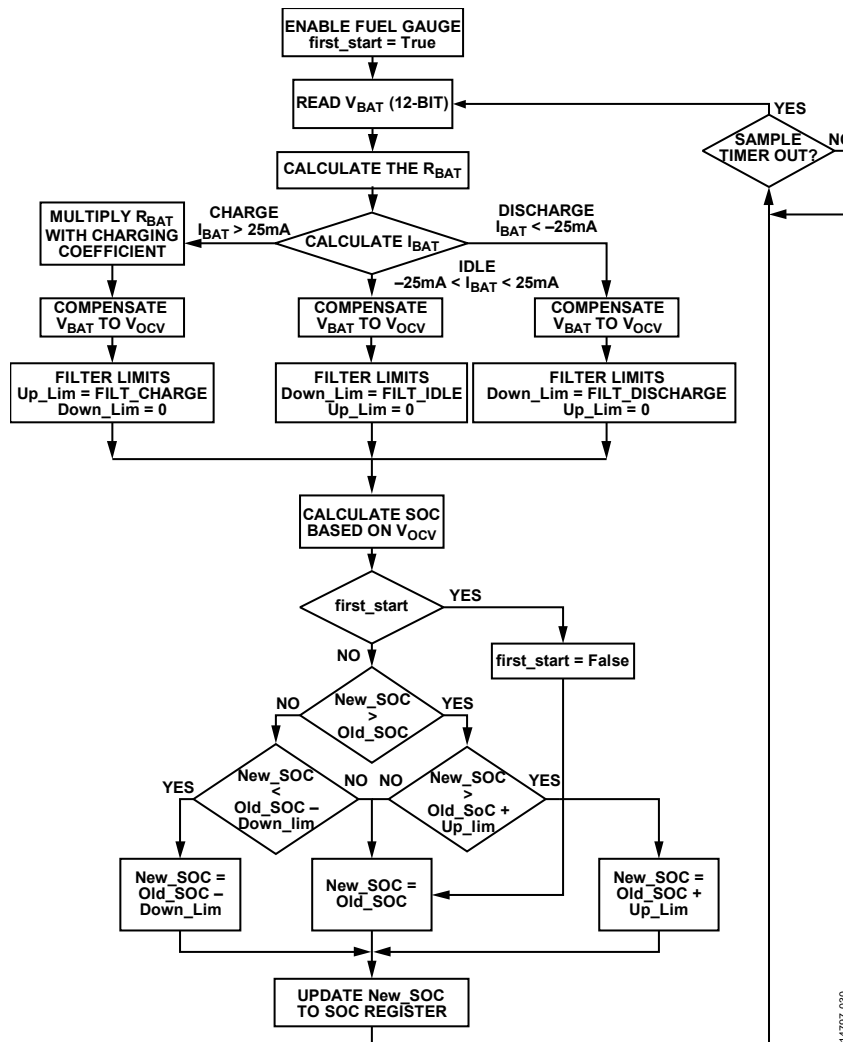

Figure 47. ADP5350 SOC Calculation Flowchart

14797-030

## BOOST AND WHITE LED DRIVERS

The [ADP5350](#) integrates a powerful 1.5 MHz frequency boost regulator with programmable LED control. Different LED configurations, like LEDs in parallel or LEDs in serial, are supported with careful design. Up to five LED strings are independently programmable up to 20 mA (typical) in 64 levels. All LED strings can be individually programmed or combined into a group to operate as the backlight LEDs or individual LED current sinks.

A full suite of safety features, including current-limit, overvoltage, LED open-circuit, and overtemperature protection, allows a robust and safe design. The integrated soft start limits inrush currents during start-up and restart attempts.

### White LED Driver

White LEDs are common in backlighting the displays of modern portable devices. White LEDs require a high forward voltage,  $V_F$  (typically 3.3 V), before conducting current and emitting light. Display panels, depending on the size, can be backlit with multiple white LEDs in series or in parallel. The LEDs need a common current passing through all of them to achieve uniform brightness. The LED, however, must be biased with a voltage greater than the sum of each LED  $V_F$  voltage before it can conduct.

The [ADP5350](#) integrates a 1.5 MHz boost regulator to power the LED bias voltage. If the LED forward voltage plus the current sink headroom voltage is higher than the battery voltage, the boost regulator turns on. If the battery voltage is higher than the sum of the LED forward voltage plus the required current sink headroom voltage, the boost regulator operates in passthrough mode.

The [ADP5350](#) uses an integrated negative channel field effect transistor (NFET) low-side current regulator for accurate brightness control, with up to five channels of current sink.

The [ADP5350](#) supports setting different LED currents for each LED string. Any mismatch in the forward voltage of the LEDs translates directly to lower efficiency, as well as lower accuracy of the current for the lower voltage LED string.

The boost regulator in the [ADP5350](#) has two operation modes, LED operation mode and boost standalone operation mode, which can be selected via the I<sup>2</sup>C-compatible interface.

### LED Operation Mode

When the boost regulator is required to provide a higher output voltage to the LED bias voltage, the boost regulator must be configured in LED operation mode by setting  $BST\_MODE = 0$  in the  $BST\_CFG$  register.

In LED operation mode, the boost regulator provides the adaptive LED bias voltage with adaptive headroom regulation to optimize the system efficiency against LED forward voltage variation and aging. The boost regulator is attached to the LED current source control and, therefore, is automatically activated

by any active LED current source. The  $EN\_BST$  bit is not effective in this mode.

Because the LED bias voltage may be coming from the battery system voltage instead of the boost output voltage (for example, LED indicators with relatively low forward voltage), those LEDs can be used in individual current sink channels by using the battery system voltage as the LED bias voltage. Use the  $BST\_BL$  bit in the  $BST\_CFG$  register to determine whether the bias voltage for individual current sink channels is coming from the boost regulator output or from the battery system voltage.

Write 0 to  $BST\_BL$  to set the boost regulator to provide the bias voltage for all active LED channels. In this configuration, the boost regulator provides the adaptive headroom regulation according to all active LED current sources, including both backlight and individual current sinks.

Write 1 to  $BST\_BL$  to set the boost regulator to provide the bias voltage only for the active LED backlight channels, excluding individual current sink. The bias voltage for an individual LED sink can be from the battery system voltage or from some other fixed rail; therefore, the headroom status in individual LED sinks does not affect the boost output regulation.  $BST\_BL$  must be set to 1 when the indicator LED is connected to the battery system voltage instead of the boost output voltage; otherwise, the boost voltage may risk an overvoltage. The adaptive headroom control in the boost regulator may include individual LED channels whose bias voltage is not coming from the boost regulator.

The boost feedback pin (FB4 pin) is tied to ground in LED operation mode.

### Boost Standalone Operation Mode

When the boost regulator is used to provide the fixed output voltage for other system uses, including organic light emitting diode (OLED) backlight, audio system, or other auxiliary circuitries, the boost regulator must be configured in standalone operation mode by setting  $BST\_MODE = 1$  in the  $BST\_CFG$  register. It is recommended that total output power be limited below 800 mW when the boost peak current is set to 600 mA.

In standalone operation mode, the boost regulator provides the adjustable output voltage,  $V_{OUT4}$ , configured by the external resistor divider.

$$V_{OUT4} = V_{FB4} \times (R_{FB1} + R_{FB2}) / R_{FB2}$$

The activation status of the boost regulator is determined by the  $EN\_BST$  bit in the  $BST\_CFG$  register. In boost standalone operation mode, all LED functions are turned off and not allowed.

In standalone operation mode, the boost feedback pin (FB4 pin) must be tied to the boost output through an external resistor divider.

Figure 48 shows the typical boost regulator diagram in standalone operation. Table 16 summarizes the difference between LED operation mode and standalone operation mode. Table 16 provides four programmable OVP thresholds according to the boost output voltage. The various OVP thresholds provide different internal compensation depending on the boost output voltage. It is strongly recommended to select the proper OVP level related to the set output voltage.

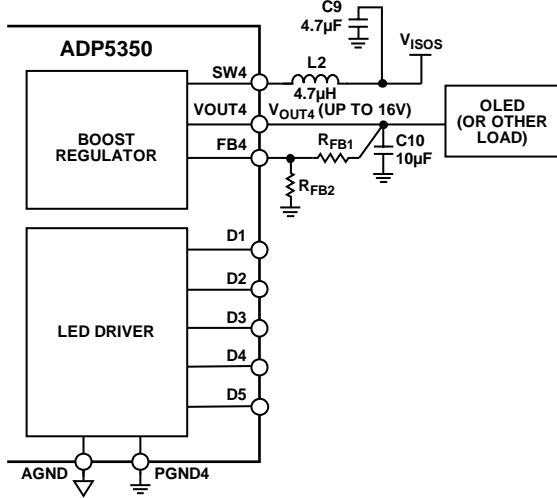

Figure 48. Boost Regulator in Standalone Operation Mode

Table 16. Two Operation Modes for the Boost Regulator

Operation	LED Operation Mode	Standalone Operation Mode
Activation Control	Activated by active LED EN_LEDx	Activated by EN_BST
Output Regulation	Adaptive to LED V <sub>f</sub> voltage variation	Fixed and determined by external resistor divider
FB4 Pin	Tied to ground	Tied to boost output via resistor divider
OVP	5.6 V, 10 V, 15 V, or 18.5 V threshold on the VOUT4 pin	5.6 V, 10 V, 15 V, or 18.5 V threshold on the VOUT4 pin

**PGOOD Indicator of Boost Output**

In boost standalone mode, the PGOOD pin can be programmed to indicate whether the boost PGOOD signal is output to the external PGOOD pin by setting the PG4\_BST\_MASK bit high in Register 0x37. The ADP5350 monitors the FB4 pin voltage, and asserts the PGOOD signal high when the FB4 pin voltage reaches up to 90% of the typical voltage with a typical 2 ms deglitch time. The PGOOD signal asserts low when the FB4 pin voltage drops to 86.5% of the typical voltage.

The boost output PGOOD status can be read via the I<sup>2</sup>C interface, Register 0x36, Bit 1.

**Soft Start**

The boost regulator in the ADP5350 includes soft start circuitry that ramps the output voltage in a controlled manner during startup, thereby limiting the inrush current of the battery. The soft start time is typically fixed at 1 ms for the boost regulator.

**Backlight Current Settings**

The backlight current setting is determined by a 6-bit code programmed by the user via the IBL\_SET[5:0] bits. This 6-bit code allows the user to set the backlight to one of 64 levels between 0 mA and 20 mA.

The ADP5350 uses a square law algorithm for the 64 levels, where the backlight current increases linearly for a corresponding increase of input code. The backlight current, in milliamperes (mA), is determined by the following equations:

$$\text{Backlight Current (mA)} = \left( \text{Code} \times \frac{\sqrt{\text{Full-Scale Current}}}{63} \right)^2$$

where:

Code is the input code programmed by the user.

Full-Scale Current is the maximum sink current allowed (typically, 20 mA).

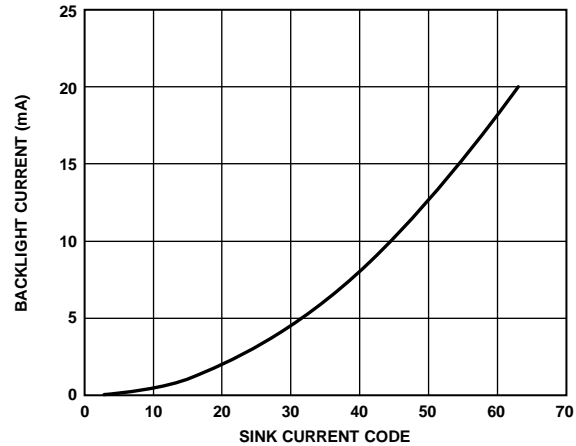

Figure 49. Backlight Current vs. Sink Current Code

**Backlight Linear Fade In and Fade Out**

When the ADP5350 operates in normal operation, the backlight can be turned on using the EN\_BL bit. The backlight turns on when EN\_BL = 1, and turns off when EN\_BL = 0.

To prevent abrupt turn on and turn off of the backlight, the ADP5350 contains timers to facilitate smooth fading between the turn on and turn off states. Fading is implemented using the square law backlight code algorithm.

The BL\_FI timer and BL\_FO timer in the BL\_FR register can be used for smooth fade in transitions from a low to high backlight setting. The BL\_FI timer and BL\_FO timer can be programmed to one of 15 settings ranging from 0.3 sec to 4.5 sec. The timer must be programmed before asserting EN\_BL.

The time programmed in the BL\_FI timer and BL\_FO timer represents the time it takes the backlight current to go from 0 mA to 20 mA. Therefore, the fading time between intermediate settings is shorter. Smaller changes in current reduces the fade time. For square law fades, the fade time is given by

$$\text{Fade Time} = \text{Fade Rate} \times (\text{Code}/63)$$

where the *Fade Rate* is as shown in Table 17.

Table 17. Available Fade In and Fade Out Times

Code	Fade Rate (sec)
0000	Fade in or fade out disabled
0001	0.3
0010	0.6
0101	0.9
0110	1.2
0111	2.1
1000	2.4
1001	2.7
1010	3.0
1011	3.3
1100	3.6
1101	3.9
1110	4.2
1111	4.5

**Backlight Fade Override**

A fade override feature allows the BL\_FI and BL\_FO timers to be overridden when the EN\_BL bit is reasserted during a fade in or fade out period and to set the backlight to its targeted current setting value immediately (see Figure 50). Setting the FOVR bit to 1 in the BST\_CFG register enables the backlight fade override feature.

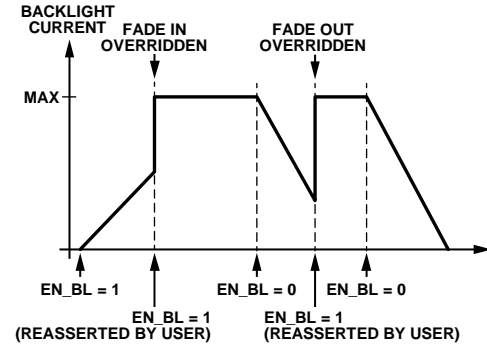

Figure 50. LED Backlight Fade Override

**Independent Sink Controls**

The LED current sink in Channel 2 to Channel 5 can be configured to operate as either part of a grouped backlight, or to operate as an independent LED channel.

Setting BL\_LEDx = 1 configures the selected LED channel (Channel 2 to Channel 5) as the part of a grouped backlight. In this setting, the backlight current setting and on/off control in Channel 1 apply to the configured channel.

Setting BL\_LEDx = 0 configures the selected LED channel (Channel 2 to Channel 5) as an independent current sink channel. Each channel current and on/off control are determined by independent register settings.

**Individual LED Blinking Timer**

The independent current sinks in Channel 3, Channel 4, and Channel 5 have additional timers to facilitate the blinking functions. The on timer and the off timer in the LEDx\_BLINK register allow individual LED current sinks to be configured in various blinking modes. Blink mode can be activated by setting the off timers to any setting other than disabled. The blink mode setting has no effect if the channel is configured as part of a grouped backlight.

The fade in and fade out function is effective in blink mode but the fade override feature is not effective in blink mode. See Figure 51 for a timing diagram of LED blinking with fading.

Some applications (for example, red/green/blue (RGB) LEDs in blink mode) need the blinking timer to be in synchronization. If the blinking LEDs are enabled in the same I<sup>2</sup>C command, the rising time of the on timer for each blinking LED is synchronized.

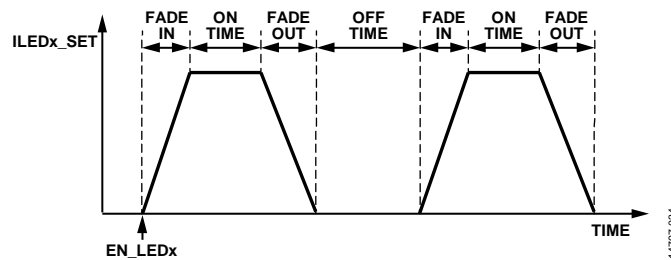

Figure 51. LED Blinking with Fading

### LEDs in Parallel

Different configurations, for example, LEDs in series or LEDs in parallel, can be supported by ADP5350.

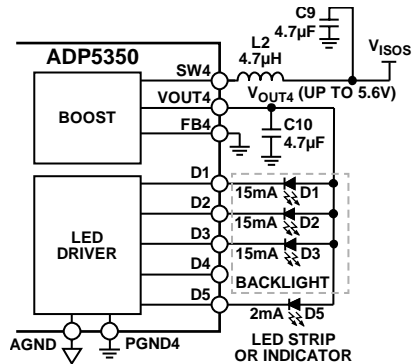

Figure 52. Three LEDs in Parallel for Grouped Backlight and One LED Strip or Indicator

Figure 52 shows three LEDs in parallel (15 mA each), in grouped backlight configuration, connected to D1, D2, and D3, and one additional LED indicator (2 mA) connected to D5.

- Configure the boost regulator as follows:
  - Set `BST_MODE = 0` to configure the boost regulator in LED operation mode.
  - Set `BST_BL = 0` to configure the boost regulator to provide the bias voltage to all current sink channels.
  - Set `BST_OVP = 1` to configure the boost OVP threshold = 5.6 V.
- Configure the grouped backlight as follows:
  - Set `BL_LED2 = 1` and `BL_LED3 = 1` to configure D1 to D3 as the grouped backlight.
  - Set `IBL[5:0] = 15 mA` for the LED grouped backlight current.
  - Set the `BL_FI` and `BL_FO` code for the fade in and fade out timer (if required).
  - Set `FOVR = 1` to enable the fading overwritten feature (if required).
- Configure the individual current sink as follows:
  - Set `ILED5 = 2 mA` for the D5 sink current.
  - Set the `LED5_ON` and `LED5_OFF` code for the blinking timer (if required).
- Set `EN_BL = 1` to enable the LED backlight.
- Set `EN_LED5 = 1` to enable the LED indicator.

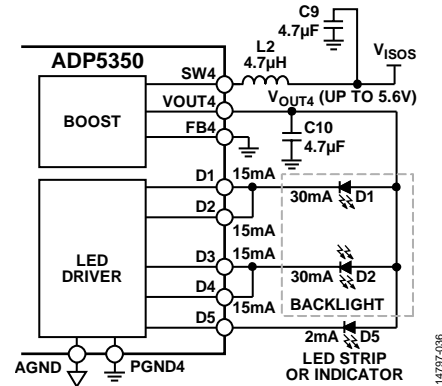

Figure 53. Two LEDs in Parallel (30 mA each) for Grouped Backlight and One LED Strip or Indicator (2 mA)

Figure 53 shows two LEDs in parallel (30 mA each), in grouped backlight configuration, connected from D1 to D4, and one additional LED indicator (2 mA) connected to D5.

- Configure the boost regulator as follows:
  - Set `BST_MODE = 0` to configure the boost regulator in LED operation mode.
  - Set `BST_BL = 0` to configure the boost regulator to provide the bias voltage to all current sink channels.
  - Set `BST_OVP = 1` to configure the boost OVP threshold = 5.6 V. Set `EN_BL` bit = 1 to enable the LED backlight.
- Configure the grouped backlight as follows:
  - Set `BL_LED2 = 1`, `BL_LED3 = 1`, and `BL_LED4 = 1` to configure D1 to D4 as the grouped backlight.
  - Set `IBL[5:0] = 15 mA` for the LED grouped backlight current (two channels in parallel with 30 mA for each LED current).
  - Set the `BL_FI` and `BL_FO` code for the fade in and fade out timer (if required).
  - Set `FOVR = 1` to enable the fading overwritten feature (if required).
- Configure the individual current sink as follows:
  - Set `ILED5 = 2 mA` for the D5 sink current.
  - Set the `LED5_ON` and `LED5_OFF` code for the blinking timer (if required).
- Set `EN_BL = 1` to enable the LED backlight.
- Set `EN_LED5 = 1` to enable the LED indicator.

### LED in Series

The **ADP5350** supports connecting LEDs in series (see Figure 54 for an example).

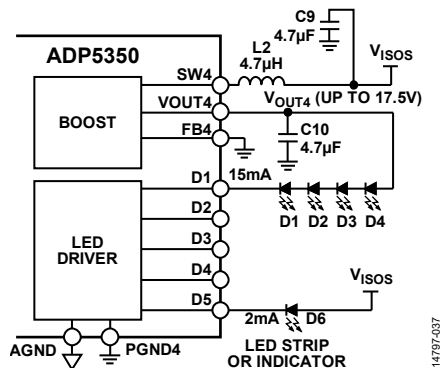

Figure 54. Four LEDs in Series (15 mA Each) for Grouped Backlight Connected to D1, and One LED Strip or Indicator (2 mA) in D5 with Connection to  $V_{ISO5}$  Rail

Figure 54 shows four LEDs in series (15 mA each), in grouped backlight configuration, connected to D1, and one additional LED indicator (2 mA) connected to D5 and the  $V_{ISO5}$  rail.

- Configure the boost regulator as follows:
  - Set `BST_MODE = 0` to configure the boost in LED operation mode.
  - Set `BST_BL = 1` to configure the boost to provide the bias voltage to the LED backlight only.
  - Set `BST_OVP = 0` to configure the boost OVP threshold = 18.5 V.
- Configure the grouped backlight as follows:
  - Set `IBL[5:0] = 15 mA` for the LED backlight current.
  - Set the `BL_FI` and `BL_FO` code for the fade in and fade out timer (if required).
  - Set `FOVR = 1` to enable the fading overwritten feature (if required).
- Configure the individual current sink as follows:
  - Set `ILED5 = 2 mA` for D5 sink current.
  - Set the `LED5_ON` and `LED5_OFF` code for the blinking timer (if required).
- Set `EN_BL = 1` to enable the LED backlight.
- Set `EN_LED5 = 1` to enable the LED indicator.

### Boost Switching Frequency

The boost regulator of the **ADP5350** operates in 1.5 MHz fixed switching frequency and it is synchronized with the switching frequency in battery charger.

### Boost Current Limit

The boost regulator in the **ADP5350** includes the peak current-limit protection circuitry to limit the amount of positive current flowing through the battery to the output. Two current-limit thresholds (600 mA or 300 mA) can be selected using the `BST_IPK` bit. The programmable current-limit threshold feature allows the use of a small size inductor for low power applications.

As the battery discharges, the lower battery voltage results in higher peak current through the battery ESR, which may cause early shutdown of other devices on the battery. The programmable current threshold can be used to change the current limit according to different battery voltages.

### Overvoltage Fault

The boost regulator contains OVP circuits to prevent damage if the  $V_{OUT4}$  voltage becomes excessive for any reason. To keep a safe output level, the integrated OVP circuit monitors the  $V_{OUT4}$  voltage. When the  $V_{OUT4}$  voltage exceeds the OVP rising threshold, the boost regulator stops switching, causing the output voltage to drop. When the  $V_{OUT4}$  voltage goes lower than the OVP falling threshold, the boost regulator begins switching, causing the output to rise. The overvoltage threshold is programmable (default of 18.5 V) in the `BST_OVP` register.

The overvoltage threshold level must be programmed according to the output voltage because the various OVP thresholds provide different internal compensation depending on the boost output voltage.

### LED Open-Circuit Protection

The LED circuit contains a headroom control circuit to minimize power loss at each current source. Therefore, the minimum feedback voltage is achieved by regulating the output voltage of the boost regulator. If any LED string is opened during normal operation, the current source headroom voltage is pulled to AGND. In this condition, LED open-circuit protection activates when the voltage on the  $D_x$  pin is less than 200 mV and the  $V_{OUT4}$  voltage rises to the OVP level. If LED open-circuit protection is triggered, the open LED channel turns off while the other LED channel continues to work, and the `LEDx_OPEN` bit is set to 1 in the `LED_STATUS` register. The open LED channel remains disabled to ensure protection against a potential LED open circuit, until the processor clears the fault register by rewriting a 1 to the fault bit or the **ADP5350** is power cycled.

When one channel is selected for independent LED operation and the bias voltage is separate from the LED backlight group (`BST_BL = 1`), the LED open-circuit protection has no effect on this channel due to the boost OVP never being detected on this channel.

### LINEAR LOW DROPOUT (LDO) REGULATORS

The **ADP5350** integrates three LDO regulators. LDO1 is a low quiescent current LDO that can be used as a supply that is always on for the system. LDO2 and LDO3 are general-purpose LDO regulators.

All LDO input power rails are supplied from the `VIN123` pin and share the input power of the control circuits with the `VIN4` pin. Thus, the `VIN123` pin must be tied to the `VIN4` pin in all applications.

The LDO regulator operates with an input voltage range of 2.7 V to 5.5 V. The wide supply range makes the regulator suitable for cascading configurations where the LDO supply

voltage is provided from the system voltage. The LDO output voltage is set by the factory fuse or I<sup>2</sup>C.

The LDO regulator provides a high power supply rejection ratio (PSRR), low output noise, and excellent line and load transient response with small 1  $\mu$ F ceramic input and output capacitors.

The LDO1, LDO2, and LDO3 fixed output voltages are set by the factory fuse and include the following options: 1.0 V, 1.1 V, 1.2 V, 1.3 V, 1.4 V, 1.5 V, 1.8 V, 2.1 V, 2.3 V, 2.5 V, 2.85 V, 3.0 V, 3.15 V, 3.3 V, 3.6 V, and 4.2 V.

#### **Load Switch Mode**

All LDO regulators can be configured as a load switch via the I<sup>2</sup>C. The load switch allows power domain isolation and helps to extend the battery life.

#### **LDO Output Discharge**

Each LDO has an output discharge feature that can be selected by the I<sup>2</sup>C. When the output discharge feature is enabled, the selected LDO output connects the internal 500  $\Omega$  load to ground and pulls down the output voltage quickly when the LDO channel is disabled.

#### **PGOOD Indicator of LDO1 Output**

The ADP5350 PGOOD pin can mask various power-good channels, including LDO1, the boost regulator, and V<sub>VBUSx</sub> by setting Register 0x37, Bit 0.

When the PGOOD pin masks the LDO1 power-good output and enables LDO1, the PGOOD pin indicates the LDO1 output voltage power-good signal, and asserts high when the VOUT1 pin voltage reaches up to 90% of the typical voltage with a typical 2 ms deglitch time. The PGOOD signal asserts low when the VOUT1 pin voltage drops to 86.5% of the typical voltage.

The default setting of the PG1\_LDO1\_MASK is a factory fuse trim that is programmable. The LDO1 power-good status can be read via the I<sup>2</sup>C interface, using Register 0x36, Bit 0.

## **THERMAL MANAGEMENT**

### ***Isothermal Charging and Thermal Early Warning***

To assist with the thermal management of the ADP5350 charger, the battery charger provides an isothermal charging function. As the on-chip power dissipation and die temperature increase, the ADP5350 charger monitors the die temperature and limits the output current when the temperature reaches T<sub>SD\_W</sub>. The die temperature is maintained at T<sub>SD\_W</sub> through the control of the charging current into the battery. A reduction in power dissipation or ambient temperature may allow the charging current to return to its original value, and the die temperature subsequently drops below T<sub>SD\_W</sub>. During isothermal charging, the THERM\_LIM flag is set to high.

The early warning bit is set if T<sub>SD\_W</sub> is exceeded. This warning bit allows the system to accommodate power consumption before thermal shutdown occurs.

### ***Thermal Shutdown***

The ADP5350 switching charger features a thermal shutdown threshold detector. If the die temperature exceeds T<sub>SD</sub>, the ADP5350 charger is disabled, and the TSD\_140 bit is set. The ADP5350 charger can be reenabled when the die temperature drops below the T<sub>SD</sub> falling limit and the TSD\_140 bit is reset. To reset the TSD\_140 bit, write to the I<sup>2</sup>C Fault Register 0x0A or cycle the power.

### ***Fault Recovery***

Before performing the following operation, it is important to ensure that the cause of the fault is rectified.

To reset the fault bits in the CHARGER\_FAULT register, cycle the power on VBUSx or write the corresponding I<sup>2</sup>C bit high.

## I<sup>2</sup>C INTERFACE

The ADP5350 includes an I<sup>2</sup>C-compatible serial interface to control the battery charging, fuel gauge, boost regulator, and LED driver, and to read back the system status.

### I<sup>2</sup>C ADDRESSES

The I<sup>2</sup>C address can be factory programmable. The I<sup>2</sup>C address options help to avoid conflicts with other I<sup>2</sup>C slave chipsets in the system. For alternative I<sup>2</sup>C chip address requirements, contact a local Analog Devices sales or distribution representative.

### SDA AND SCL PINS

The ADP5350 has two dedicated I<sup>2</sup>C interface pins, SDA and SCL. SDA is an open-drain line for receiving and transmitting data. SCL is an input line for receiving the clock signal. Pull up these pins to an external input/output supply using external resistors.

Serial data is transferred on the rising edge of SCL. The read data is generated at the SDA pin in read mode.

The subaddress content selects the ADP5350 registers to be written to first. The ADP5350 sends an acknowledgement to the master after the 8-bit data byte is written (see Figure 55 for an example of the I<sup>2</sup>C write sequence to a single register). The ADP5350 increments the subaddress automatically and starts receiving a data byte at the next register until the master sends an I<sup>2</sup>C stop as shown in Figure 56.

Figure 57 shows the I<sup>2</sup>C read sequence of a single register. The ADP5350 sends the data from the register denoted by the subaddress and increments the subaddress automatically, sending data from the next register until the master sends an I<sup>2</sup>C stop condition as shown in Figure 58.

### DEFAULT RESET

The ADP5350 contains one write only register, DEFAULT\_SET, to reset all registers to the factory default values.

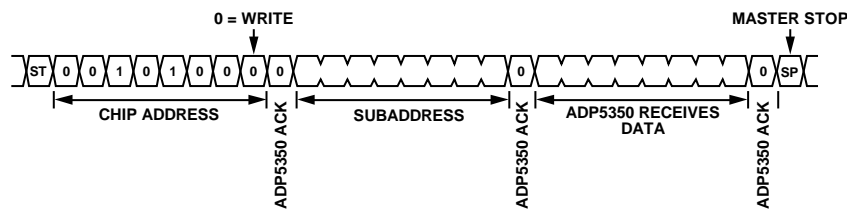

Figure 55. I<sup>2</sup>C Single Register Write Sequence

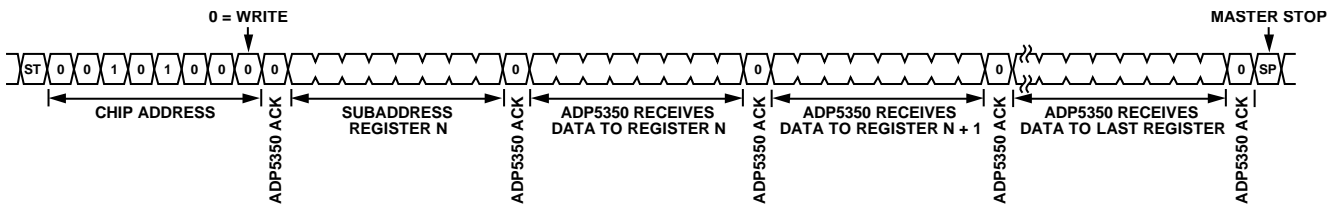

Figure 56. I<sup>2</sup>C Multiple Register Write Sequence

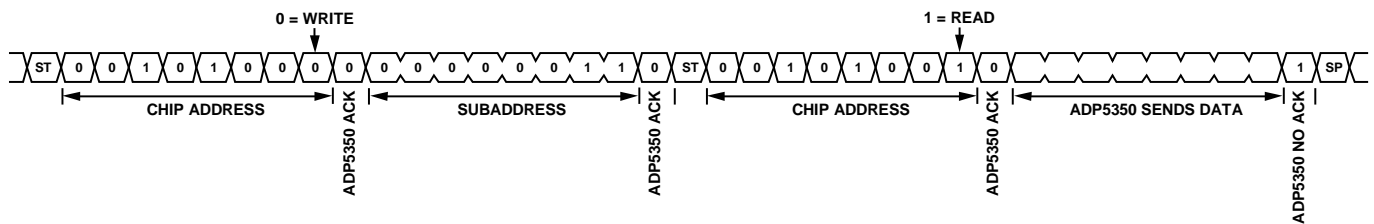

Figure 57. I<sup>2</sup>C Single Register Read Sequence

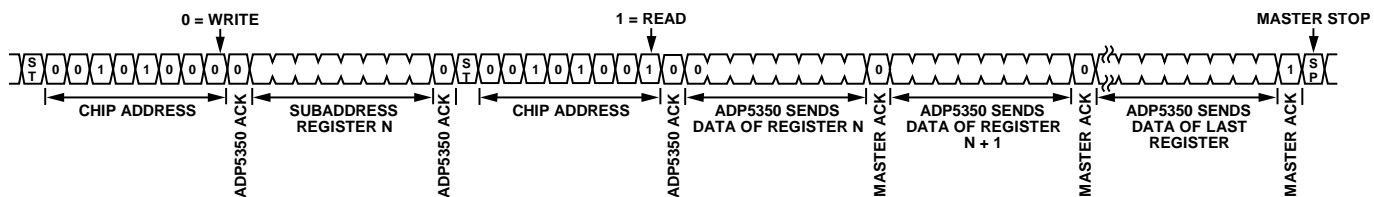

Figure 58. I<sup>2</sup>C Multiple Register Read Sequence

## INTERRUPTS

The [ADP5350](#) provides an interrupt output (the  $\overline{\text{INT}}$  pin) for fault conditions. During normal operation, when the  $\overline{\text{INT}}$  pin is pulled high, use an external pull-up resistor. When a fault condition occurs, the [ADP5350](#) pulls the  $\overline{\text{INT}}$  pin low to alert the I<sup>2</sup>C host that a fault condition occurred.

Many different interrupt sources can trigger the  $\overline{\text{INT}}$  pin. By default, no interrupt sources are configured. To select one or more interrupt sources to trigger the  $\overline{\text{INT}}$  pin, set the appropriate bits to 1 in the CHARGER\_INTERRUPT\_ENABLE register and the BOOST\_LDO\_INTERRUPT\_ENABLE register.

When the  $\overline{\text{INT}}$  pin is triggered, one or more bits in the CHARGER\_INTERRUPT\_FLAG register and the BOOST\_LDO\_INTERRUPT\_FLAG register are set to 1. The fault condition that triggered the  $\overline{\text{INT}}$  pin can be read from the CHARGER\_INTERRUPT\_FLAG register and the BOOST\_LDO\_INTERRUPT\_FLAG register.

To clear an interrupt, read the appropriate bit in the CHARGER\_INTERRUPT\_FLAG register and the BOOST\_LDO\_INTERRUPT\_FLAG register, or power cycle the [ADP5350](#).

## CONTROL REGISTER MAP

Table 18. Register Map

Address (Hex)	Register Name	D7	D6	D5	D4	D3	D2	D1	D0	
0x00	Manufacture and model ID	MANUF[3:0]				Model[3:0]				
0x01	Silicon revision	Not used				REV[3:0]				
0x02	CHARGER_VBUS_ILIM	Not used				ILIM[3:0]				
0x03	CHARGER_TERMINATION_SETTING	VTRM[5:0]						IEND[1:0]		
0x04	CHARGER_CURRENT_SETTING	C_20_EOC	C_10_EOC	ICHG[3:0]			ITRK_DEAD[1:0]			
0x05	CHARGER_VOLTAGE_THRESHOLD	Not used	VRCH[1:0]		VTRK_DEAD[1:0]		VWEAK[2:0]			
0x06	CHARGER_TIMER_SETTING	Not used	EN_TEND	EN_CHG_TIMER	CHG_TMR_PERIOD		EN_WD	WD_PERIOD	RESET_WD	
0x07	CHARGER_FUNCTION_SETTING1	EN_JEITA	DIS_IPK_SD	EN_BMON	EN_THR	EN_DCDC	EN_EOC	EN_TRK	EN_CHG	
0x08	CHARGER_STATUS1	VBUS_OV	Not used	VBUS_ILIM	THERM_LIM	CHDONE	CHARGER_STATUS[2:0]			
0x09	CHARGER_STATUS2	THR_STATUS[2:0]			IPK_STAT	Not used	BATTERY_STATUS[2:0]			
0x0A	CHARGER_FAULT	Not used				BAT_SHR	IND_PEAK	TSD_130	TSD_140	
0x0B	BATTERY_SHORT	TBAT_SHR[2:0]			Not used		VBAT_SHR[2:0]			
0x0C	BATTERY_THERMISTOR_CONTROL	ILIM_JEITA_COOL	TBAT_LOW	TBAT_HIGH	R_NTC	BETA_NTC[3:0]				
0x0D	V_SOC_0	V_SOC_0[7:0]								
0x0E	V_SOC_5	V_SOC_5[7:0]								
0x0F	V_SOC_11	V_SOC_11[7:0]								
0x10	V_SOC_19	V_SOC_19[7:0]								
0x11	V_SOC_28	V_SOC_28[7:0]								
0x12	V_SOC_41	V_SOC_41[7:0]								
0x13	V_SOC_55	V_SOC_55[7:0]								
0x14	V_SOC_69	V_SOC_69[7:0]								
0x15	V_SOC_84	V_SOC_84[7:0]								
0x16	V_SOC_100	V_SOC_100[7:0]								
0x17	FILTER_SETTING1	Not used	FILTER_CHARGE[2:0]			Not used	FILTER_DISCHARGE[2:0]			
0x18	FILTER_SETTING2	Not used						FILT_IDLE[1:0]		
0x19	RBAT_0	RBAT_0[7:0]								
0x1A	RBAT_10	RBAT_10[7:0]								
0x1B	RBAT_20	RBAT_20[7:0]								
0x1C	RBAT_30	RBAT_30[7:0]								
0x1D	RBAT_40	RBAT_40[7:0]								
0x1E	RBAT_60	RBAT_60[7:0]								
0x1F	K_RBAT_CHARGE	Not used		K_RBAT_SOC[1:0]		K_RBAT_CHARGE[3:0]				
0x20	BAT_TEMP	Not used	BAT_TEMP_SOURCE	BAT_TEMP[5:0]						
0x21	BAT_SOC	Not used	BAT_SOC[6:0]							
0x22	VBAT_READ_H	VBAT_READ[12:5]								
0x23	VBAT_READ_L	VBAT_READ[4:0]				Not used				

Address (Hex)	Register Name	D7	D6	D5	D4	D3	D2	D1	D0
0x24	FUEL_GAUGE_MODE	Not used					SLEEP_UPDATE_TIME	FUEL_GAUGE_MODE	FUEL_GAUGE_ENABLE
0x25	SOC_RESET	SOC reset	Not used						
0x26	BST_LED_CTRL	Not used		EN_BST	EN_LED5	EN_LED4	EN_LED3	EN_LED2	EN_BL
0x27	BST_CFG	BST_MODE	BST_BL	FOVR	Not used	BST_OVP		Not used	BST_IPK
0x28	IBL_SET	Not used		IBL[5:0]					
0x29	ILED2_SET	BL_LED2	Not used	ILED2[5:0]					
0x2A	ILED3_SET	BL_LED3	Not used	ILED3[5:0]					
0x2B	ILED4_SET	BL_LED4	Not used	ILED4[5:0]					
0x02C	ILED5_SET	BL_LED5	Not used	ILED5[5:0]					
0x2D	BL_FR	BL_FO[3:0]				BL_FI[3:0]			
0x2E	LED3_BLINK	LED3_OFF[3:0]				LED3_ON[3:0]			
0x2F	LED4_BLINK	LED4_OFF[3:0]				LED4_ON[3:0]			
0x30	LED5_BLINK	LED5_OFF[3:0]				LED5_ON[3:0]			
0x31	LED_STATUS	Not used			LED5_OPEN	LED4_OPEN	LED3_OPEN	LED2_OPEN	LED1_OPEN
0x32	LDO_CTRL	Not used					EN_LDO3	EN_LDO2	EN_LDO1
0x33	LDO_CFG	Not used	DSCG_LDO3	DSCG_LDO2	DSCG_LDO1	Not used	MODE_LDO3	MODE_LDO2	MODE_LDO1
0x34	VID_LDO12	VID_LDO2[3:0]				VID_LDO1[3:0]			
0x35	VID_LDO3	Not used					VID_LDO3[3:0]		
0x36	PGOOD_STATUS	Not used				VBUSOK	BATOK	PG4_BST	PG1_LDO1
0x37	PGOOD_MASK	Not used				VBUSOK_MASK	BATOK_MASK	PG4_BST_MASK	PG1_LDO1_MASK
0x38	CHARGER_INTERRUPT_ENABLE	EN_IND_PEAK_INT	EN_THERM_LIM_INT	EN_WD_INT	EN_TSD_INT	EN_THR_INT	EN_BAT_INT	EN_CHG_INT	EN_VIN_INT
0x39	CHARGER_INTERRUPT_FLAG	IND_PEAK_INT	THERM_LIM_INT	WD_INT	TSD_INT	THR_INT	BAT_INT	CHG_INT	VIN_INT
0x3A	BOOST_LDO_INTERRUPT_ENABLE	Not used					EN_LED_OPEN_INT	EN_PG4_BST_INT	EN_PG1_LDO1_INT
0x3B	BOOST_LDO_INTERRUPT_FLAG	Not used					LED_OPEN_INT	PG4_BST_INT	PG1_LDO1_INT
0x3C	DEFAULT_SET	DEFAULT_SET							
0x3D	NTC47K_SET	Not used							NTC_47K

**REGISTER BIT DESCRIPTIONS****Table 19. Manufacturer and Model ID, Register Address 0x00 Bit Descriptions**

Bit No.	Mnemonic	Access	Default	Description
[7:4]	MANUF[3:0]	R	0001	The 4-bit manufacturer identification bus.
[3:0]	Model[3:0]	R	1011	The 4-bit model identification bus.

**Table 20. Silicon Revision, Register Address 0x01 Bit Descriptions**

Bit No.	Mnemonic	Access	Default	Description
[7:4]	Not used	R		
[3:0]	REV[3:0]	R	0011	The 4-bit silicon revision identification bus.

**Table 21. CHARGER\_VBUS\_ILIM, Register Address 0x02 Bit Descriptions**

Bit No.	Mnemonic	Access	Default	Description
[7:4]	Not used	R		Not used.
[3:0]	ILIM[3:0]	R/W	0000	VBUSx pin input current-limit programming bus. The current into VBUSx can be limited to the following programmed values: 0000 = 100 mA. 0001 = 150 mA. 0010 = 200 mA. 0011 = 300 mA. 0100 = 400 mA. 0101 = 500 mA. 0110 = 600 mA. 0111 = 700 mA. 1000 = 800 mA. 1001 = 900 mA. 1010 = 1000 mA. 1011 = 1100 mA. 1100 = 1200 mA. 1101 = 1300 mA. 1110 = 1400 mA. 1111 = 1500 mA.

**Table 22. CHARGER\_TERMINATION\_SETTINGS, Register Address 0x03 Bit Descriptions**

Bit No.	Mnemonic	Access	Default	Description
[7:2]	VTRM[5:0]	R/W	100011	Termination voltage programming bus. The values of the float voltage can be programmed to the following values: 000000 = 3.50 V. 000001 = 3.52 V. 000010 = 3.54 V. 000011 = 3.56 V. 000100 = 3.58 V. 000101 = 3.60 V. 000110 = 3.62 V. 000111 = 3.64 V. 001000 = 3.66 V. 001001 = 3.68 V. 001010 = 3.70 V. 001011 = 3.72 V. 001100 = 3.74 V. 001101 = 3.76 V. 001110 = 3.78 V. 001111 = 3.80 V. 010000 = 3.82 V.

Bit No.	Mnemonic	Access	Default	Description
				010001 = 3.84 V. 010010 = 3.86 V. 010011 = 3.88 V. 010100 = 3.90 V. 010101 = 3.92 V. 010110 = 3.94 V. 010111 = 3.96 V. 011000 = 3.98 V. 011001 = 4.00 V. 011010 = 4.02 V. 011011 = 4.04 V. 011100 = 4.06 V. 011101 = 4.08 V. 011110 = 4.10 V. 011111 = 4.12 V. 100000 = 4.14 V. 100001 = 4.16 V. 100010 = 4.18 V. 100011 = 4.20 V. 100100 = 4.22 V. 100101 = 4.24 V. 100110 = 4.26 V. 100111 = 4.28 V. 101000 = 4.30 V. 101001 = 4.32 V. 101010 = 4.34 V. 101011 = 4.36 V. 101100 = 4.38 V. 101101 = 4.40 V. 101110 = 4.42 V. 101111 = 4.44 V. 110000 = 4.46 V. 110001 = 4.48 V. 110010 to 111111 = 4.5 V.
[1:0]	IEND[1:0]	R/W	01	Termination current programming bus. The values of the termination current can be programmed to the following values: 00 = 25 mA. 01 = 35 mA. 10 = 45 mA. 11 = 55 mA.

Table 23. CHARGER\_CURRENT\_SETTING, Register Address 0x04 Bit Descriptions

Bit No.	Mnemonic	Access	Default	Description
7	C_20_EOC	R/W	0	This bit has priority over the other settings (C_10_EOC and IEND). When this bit is set to high, 1/20 C programming is used. The minimum value is 25 mA.
6	C_10_EOC	R/W	0	This bit has priority over the other setting (IEND) but not C_20_EOC. When this bit is set to high, 1/10 C programming is used unless C_20_EOC is set to high. The minimum value is 25 mA.

Bit No.	Mnemonic	Access	Default	Description
[5:2]	ICHG[3:0]	R/W	1100	Fast charge current programming bus. The values of the constant current charge can be programmed to the following values: 0000 = 25mA. 0001 = 50 mA. 0010 = 75 mA. 0011 = 100 mA. 0100 = 125 mA. 0101 = 150 mA. 0110 = 200 mA. 0111 = 250 mA. 1000 = 300 mA. 1001 = 350 mA. 1010 = 400 mA. 1011 = 450 mA. 1100 = 500 mA. 1101 = 550 mA. 1110 = 600 mA. 1111 = 650 mA.
[1:0]	ITRK_DEAD[1:0]	R/W	10	Trickle and weak charge current programming bus. The values of the trickle and weak charge currents can be programmed as per the following values: 00 = 5 mA. 01 = 10 mA. 10 = 20 mA. 11 = 50 mA.

Table 24. CHARGER\_VOLTAGE\_THRESHOLD, Register Address 0x05 Bit Descriptions

Bit No.	Mnemonic	Access	Default	Description
7	Not used	R		Not used.
[6:5]	VRCH[1:0]	R/W	11	Recharge voltage programming bus. The values of the recharge threshold can be programmed as per the following values: 00 = 80 mV. 01 = 140 mV. 10 = 200 mV. 11 = 260 mV.
[4:3]	VTRK_DEAD[1:0]	R/W	01	Trickle to fast charge dead battery voltage programming bus. The values of the trickle to fast charge threshold can be programmed to the following values: 00 = 2.4 V. 01 = 2.5 V. 10 = 2.6 V. 11 = 3.3 V.
[2:0]	VWEAK[2:0]	R/W	011	Weak battery voltage rising threshold. The values of the weak battery voltage rising threshold can be programmed to the following values: 000 = 2.7 V. 001 = 2.8 V. 010 = 2.9 V. 011 = 3.0 V. 100 = 3.1 V. 101 = 3.2 V. 110 = 3.3 V. 111 = 3.4 V.

Table 25. CHARGER\_TIMER\_SETTING, Register Address 0x06 Bit Descriptions

Bit No.	Mnemonic	Access	Default	Description
7	Not used	R		Not used.
6	EN_TEND	R/W	1	When low, this bit disables the charge complete timer ( $t_{END}$ ), and a 31 ms deglitch timer remains on this function.
5	EN_CHG_TIMER	R/W	1	When high, the trickle/fast charge timer is enabled.
[4:3]	CHG_TMR_PERIOD	R/W	11	Trickle/fast charge timer period. 00 = 15 minutes/150 minutes. 01 = 30 minutes/300 minutes. 10 = 45 minutes/450 minutes. 11 = 60 minutes/600 minutes.
2	EN_WD	R/W	0	0 = the watchdog timer is disabled even when $V_{BSNS}$ exceeds $V_{TRK\_DEAD}$ . 1 = the watchdog timer safety timer is enabled.
1	WD_PERIOD	R/W	0	Watchdog safety timer period. 0 = 32 sec to 40 min. 1 = 64 sec to 40 min.
0	RESET_WD	W	0	When this bit is high, the watchdog safety timer resets. This bit is reset automatically.

Table 26. CHARGER\_FUNCTION\_SETTING1, Register Address 0x07 Bit Descriptions

Bit No.	Mnemonic	Access	Default	Description
7	EN_JEITA	R/W	0	When low, this bit disables the JEITA Li-Ion temperature battery charging specification.
6	DIS_IPK_SD	R/W	1	When high, this bit disables the automatic shutdown of the device if four peak inductor current limits are reached in succession. In addition, when this bit is high, it only flags the IPK_STAT status bit.
5	EN_BMON	R/W	0	When this bit is high, the battery monitor is enabled even when the voltage at the VBUSx pins is below $V_{VBUSOK\_FALL}$ .
4	EN_THR	R/W	0	When this bit is high, the THR current source is enabled even when the voltage at the VBUSx pins is below $V_{VBUSOK\_FALL}$ .
3	EN_DCDC	R/W	1	When this bit is low, the dc-to-dc converter is disabled. When this bit is high, the dc-to-dc converter is enabled.
2	EN_EOC	R/W	1	When this bit is high, end of charge is allowed.
1	EN_TRK	R/W	1	When this bit is low, trickle charger is disabled and the dc-to-dc converter is enabled.
0	EN_CHG	R/W	Factory setting	When this bit is low, charging is disabled. When this bit is high and EN_DCDC = high, charging is enabled.

Table 27. CHARGER\_STATUS1, Register Address 0x08 Bit Descriptions

Bit No.	Mnemonic	Access	Default	Description
7	VBUS_OV	R	Not applicable	When high, this bit indicates that the voltage at the VBUSx pins exceeds $V_{VBUS\_OV}$ .
6	Not used	R		Not used.
5	VBUS_ILIM	R	Not applicable	When high, this bit indicates that the current into a VBUSx pin is limited by the high voltage blocking FET and the charger is not running at the full programmed $I_{CHG}$ .
4	THERM_LIM	R	Not applicable	When high, this bit indicates that the charger is not running at the full programmed $I_{CHG}$ but is limited by the die temperature.
3	CHDONE	R	Not applicable	When high, this bit indicates the end of charge cycle is reached. This bit latches on, in that it does not reset to low when the $V_{RCH}$ threshold is breached.

Bit No.	Mnemonic	Access	Default	Description
[2:0]	CHARGER_STATUS[2:0]	R	Not applicable	Charger status bus. 000 = off. 001 = trickle charge. 010 = fast charge (CC mode). 011 = fast charge (CV mode). 100 = charge complete. 101 = suspend. 110 = trickle, fast, or safety charge timer expired. 111 = battery detection.

Table 28. CHARGER\_STATUS2, Register Address 0x09 Bit Descriptions

Bit No.	Mnemonic	Access	Default	Description
[7:5]	THR_STATUS[2:0]	R	Not applicable	THR pin status. 000 = off. 001 = battery cold. 010 = battery cool. 011 = battery warm. 100 = battery hot. 111 = thermistor is in normal operating temperature, between the battery cool and battery warm settings.
4	IPK_STAT	R	Not applicable	Peak current limit status bit. Set high if four or more peak inductor current limits are reached in succession.
3	Not used	R		Not used.
[2:0]	BATTERY_STATUS[2:0]	R	Not applicable	Battery status bus. 000 = battery monitor off. 001 = no battery. 010 = $V_{BSNS} < V_{TRK}$ . 011 = $V_{TRK} \leq V_{BSNS} < V_{WEAK}$ . 100 = $V_{BSNS} \geq V_{WEAK}$ .

Table 29. CHARGER\_FAULT, Register Address 0x0A Bit Descriptions<sup>1</sup>

Bit No.	Mnemonic	Access	Default	Description
[7:4]	Not used	R		Not used.
3	BAT_SHR	R/W	0	When this bit is high, a battery short circuit is detected.
2	IND_PEAK	R/W	0	When this bit is high, an inductor peak current-limit fault has occurred.
1	TSD_130	R/W	0	When this bit is high, the overtemperature early warning has occurred.
0	TSD_140	R/W	0	When this bit is high, the overtemperature condition is detected. The device shuts down due to an overtemperature condition.

<sup>1</sup> To reset the fault bits in the CHARGER\_FAULT register, cycle the power on VBUSx, or read and then write the corresponding I<sup>2</sup>C bit high continuously.

Table 30. BATTERY\_SHORT, Register Address 0x0B Bit Descriptions

Bit No.	Mnemonic	Access	Default	Description
[7:5]	TBAT_SHR[2:0]	R/W	100	Battery short timeout timer: 000 = 1 sec 001 = 2 sec 010 = 4 sec 011 = 10 sec 100 = 30 sec 101 = 60 sec 110 = 120 sec 111 = 180 sec

Bit No.	Mnemonic	Access	Default	Description
[4:3]	Not used	R		Not used.
[2:0]	VBAT_SHR[2:0]	R/W	100	Battery short voltage threshold level: 000 = 2.0 V 001 = 2.1 V 010 = 2.2 V 011 = 2.3 V 100 = 2.4 V 101 = 2.5 V 110 = 2.6 V 111 = 2.7 V

Table 31. BATTERY\_THERMISTOR\_CONTROL, Register Address 0x0C Bit Descriptions

Bit No.	Mnemonic	Access	Default	Description
7	ILIM_JEITA_COOL	R/W	0	Selects the battery charging current when in the cool temperature range of 0°C and 10°C (see Table 14). 0 = approximately 50% of programmed charge current. 1 = approximately 10% of programmed charge current.
6	TBAT_LOW	R/W	0	Selects the battery temperature low threshold. When the battery temperature is lower than TBAT_LOW, charging stops. 0 = 0°C. 1 = 10°C.
5	TBAT_HIGH	R/W	1	Selects the battery temperature high threshold. When the battery temperature is higher than TBAT_HIGH, charging stops. 0 = 45°C. 1 = 60°C.
4	R_NTC	R/W	Factory setting	Selects the battery thermistor NTC resistance. 0 = 10 kΩ at 25°C. 1 = 100 kΩ or 47 kΩ at 25°C.
[3:0]	BETA_NTC <sup>1</sup>	R/W	Factory setting	4-bit programming bus for NTC beta setting. 0000 = 2350. 0001 = 2600. 0010 = 2750. 0011 = 3000. 0100 = 3150. 0101 = 3350. 0110 = 3500. 0111 = 3600. 1000 = 3800. 1001 = 4000. 1010 = 4200. 1011 = 4400. 1100 = 4600. 1101 = 4800. 1110 = 5000. 1111 = 5200.

<sup>1</sup> The BETA\_NTC bits are trimmed by factory setting; writing these bits in the application is not recommended.

Table 32. V\_SOC\_0, Register Address 0x0D Bit Descriptions

Bit No.	Mnemonic	Access	Default	Description
[7:0]	V_SOC_0	R/W	0x7C	The battery voltage when SOC is 0%. The default voltage is 3.5 V. Battery voltage (V) = (2.5 + V_SOC_0 × 0.008).

Table 33. V\_SOC\_5, Register Address 0x0E Bit Descriptions

Bit No.	Mnemonic	Access	Default	Description
[7:0]	V_SOC_5	R/W	0x91	The battery voltage when SOC is 5%. The default voltage is 3.66 V. Battery voltage (V) = (2.5 + V_SOC_5 × 0.008).

Table 34. V\_SOC\_11, Register Address 0x0F Bit Descriptions

Bit No.	Mnemonic	Access	Default	Description
[7:0]	V_SOC_11	R/W	0x94	The battery voltage when SOC is 11%. The default voltage is 3.684 V. Battery voltage (V) = (2.5 + V_SOC_11 × 0.008).

Table 35. V\_SOC\_19, Register Address 0x10 Bit Descriptions

Bit No.	Mnemonic	Access	Default	Description
[7:0]	V_SOC_19	R/W	0x99	The battery voltage when SOC is 19%. The default voltage is 3.724 V. Battery voltage (V) = (2.5 + V_SOC_19 × 0.008).

Table 36. V\_SOC\_28, Register Address 0x11 Bit Descriptions

Bit No.	Mnemonic	Access	Default	Description
[7:0]	V_SOC_28	R/W	0x9E	The battery voltage when SOC is 28%. The default voltage is 3.764 V. Battery voltage (V) = (2.5 + V_SOC_28 × 0.008).

Table 37. V\_SOC\_41, Register Address 0x12 Bit Descriptions

Bit No.	Mnemonic	Access	Default	Description
[7:0]	V_SOC_41	R/W	0xA3	The battery voltage when SOC is 41%. The default voltage is 3.804 V. Battery voltage (V) = (2.5 + V_SOC_41 × 0.008)

Table 38. V\_SOC\_55, Register Address 0x13 Bit Descriptions

Bit No.	Mnemonic	Access	Default	Description
[7:0]	V_SOC_55	R/W	0xAB	The battery voltage when SOC is 55%. The default voltage is 3.868 V. Battery voltage (V) = (2.5 + V_SOC_55 × 0.008).

Table 39. V\_SOC\_69, Register Address 0x14 Bit Descriptions

Bit No.	Mnemonic	Access	Default	Description
[7:0]	V_SOC_69	R/W	0xB5	The battery voltage when SOC is 69%. The default voltage is 3.948 V. Battery voltage (V) = (2.5 + V_SOC_69 × 0.008).

Table 40. V\_SOC\_84, Register Address 0x15 Bit Descriptions

Bit No.	Mnemonic	Access	Default	Description
[7:0]	V_SOC_84	R/W	0xC4	The battery voltage when SOC is 84%. The default voltage is 4.068 V. Battery voltage (V) = (2.5 + V_SOC_84 × 0.008)

Table 41. V\_SOC\_100, Register Address 0x16 Bit Descriptions

Bit No.	Mnemonic	Access	Default	Description
[7:0]	V_SOC_100	R/W	0xD5	The battery voltage when SOC is 100%. The default voltage is 4.204 V. Battery voltage (V) = (2.5 + V_SOC_100 × 0.008).

Table 42. FILTER\_SETTING1, Register Address 0x17 Bit Descriptions

Bit No.	Mnemonic	Access	Default	Description
7	Not used	R		Not used.
[6:4]	FILTER_CHARGE	R/W	100	The filter limit (in C rate) of SOC in battery charging mode. The C rate is the battery charge or discharge current rate over the battery capacity. 000 = 0.125 C. 001 = 0.25 C. 010 = 0.5 C. 011 = 0.75 C. 100 = 1 C. 101 = 1.5 C. 110 = 2 C. 111 = 3 C.
3	Not used	R		Not used.
[2:0]	FILTER_DISCHARGE	R/W	010	The filter limit (in C rate) of SOC in battery discharging mode. The C rate is the battery charge or discharge current rate over the battery capacity. 000 = 0.125 C. 001 = 0.25 C. 010 = 0.5 C. 011 = 0.75 C. 100 = 1 C. 101 = 1.5 C. 110 = 2 C. 111 = 3 C.

Table 43. FILTER\_SETTING2, Register Address 0x18 Bit Descriptions

Bit No.	Mnemonic	Access	Default	Description
[7:2]	Not used	R/W	000000	Not used.
[1:0]	FILTER_IDLE	R/W	00	The filter limit of SOC during battery idle mode. 00 = FILTER_CHARGE/8. 01 = FILTER_CHARGE/16. 10 = FILTER_CHARGE/32. 11 = FILTER_CHARGE/64.

Table 44. RBAT\_0, Register Address 0x19 Bit Descriptions

Bit No.	Mnemonic	Access	Default	Description
[7:0]	RBAT_0	R/W	0x3F	The battery internal resistance at 0°C. The resistance range is 0 mΩ to 8160 mΩ and the default resistance is 2016 mΩ. Resistance value = RBAT_0 × 32 mΩ.

Table 45. RBAT\_10, Register Address 0x1A Bit Descriptions

Bit No.	Mnemonic	Access	Default	Description
[7:0]	RBAT_10	R/W	0x3F	The battery internal resistance at 10°C. The resistance range is 0 mΩ to 8160 mΩ and the default resistance is 2016 mΩ. Resistance value = RBAT_10 × 32 mΩ.

Table 46. RBAT\_20, Register Address 0x1B Bit Descriptions

Bit No.	Mnemonic	Access	Default	Description
[7:0]	RBAT_20	R/W	0x3F	The battery internal resistance at 20°C. The resistance range is 0 mΩ to 8160 mΩ and the default resistance is 2016 mΩ. Resistance value = RBAT_20 × 32 mΩ.

Table 47. RBAT\_30, Register Address 0x1C Bit Descriptions

Bit No.	Mnemonic	Access	Default	Description
[7:0]	RBAT_30	R/W	0x3F	The battery internal resistance at 30°C. The resistance range is 0 mΩ to 8160 mΩ and the default resistance is 2016 mΩ. Resistance value = RBAT_30 × 32 mΩ.

Table 48. RBAT\_40, Register Address 0x1D Bit Descriptions

Bit No.	Mnemonic	Access	Default	Description
[7:0]	RBAT_40	R/W	0x3F	The battery internal resistance at 40°C. The resistance range is 0 mΩ to 8160 mΩ and the default resistance is 2016 mΩ. Resistance value = RBAT_40 × 32 mΩ.

Table 49. RBAT\_60, Register Address 0x1E Bit Descriptions

Bit No.	Mnemonic	Access	Default	Description
[7:0]	RBAT_60	R/W	0x3F	The battery internal resistance at 60°C. The resistance range is 0 mΩ to 8160 mΩ and the default resistance is 2016 mΩ. Resistance value = RBAT_60 × 32 mΩ.

Table 50. K\_RBAT\_CHARGE, Register Address 0x1F Bit Descriptions

Bit No.	Mnemonic	Access	Default	Description
[7:6]	Not used	R		Not used.
[5:4]	K_RBAT_SOC	R/W	00	Battery internal resistance coefficient less than 20% capacity. 00 = RBAT at 0% SOC = R <sub>BAT</sub> at 20% SOC. 01 = R <sub>BAT</sub> at 0% SOC = 2 × R <sub>BAT</sub> at 20% SOC. 10 = R <sub>BAT</sub> at 0% SOC = 4 × R <sub>BAT</sub> at 20% SOC. 11 = R <sub>BAT</sub> at 0% SOC = 8 × R <sub>BAT</sub> at 20% SOC.
[3:0]	K_RBAT_CHARGE	R/W	1000	Battery internal resistance coefficient for charging. The coefficient = 0.75 + K_RBAT_CHARGE/32.

Table 51. BAT\_TEMP, Register Address 0x20 Bit Descriptions

Bit No.	Mnemonic	Access	Default	Description
7	Not used	R		Not used.
6	BAT_TEMP_SOURCE	R/W	0	Battery temperature source selection bit. 0: from THR input. 1: from I <sup>2</sup> C.
[5:0]	BAT_TEMP	R/W	11011	Battery temperature from I <sup>2</sup> C. The program battery temperature range is between -2°C and +61°C. Temperature value (°C) = (BAT_TEMP - 2).

Table 52. BAT\_SOC, Register Address 0x21 Bit Descriptions

Bit No.	Mnemonic	Access	Default	Description
7	Not used	R		Not used.
[6:0]	BAT_SOC	R	Not applicable	Battery state of charge. SOC = BAT_SOC %, only valued between 0% and 100%.

Table 53. VBAT\_READ\_H, Register Address 0x22 Bit Descriptions

Bit No.	Mnemonic	Access	Default	Description
[7:0]	VBAT_READ[12:5]	R	Not applicable	The battery voltage reading, highest eight bits, unit is mV. $V_{BAT} (mV) = (VBAT\_READ\_H \times 32 + VBAT\_READ\_L/8)$ .

Table 54. VBAT\_READ\_L, Register Address 0x23 Bit Descriptions

Bit No.	Mnemonic	Access	Default	Description
[7:3]	VBAT_READ[4:0]	R	Not applicable	The battery voltage reading, lowest 5 bits, unit is mV. $V_{BAT} (mV) = (VBAT\_READ\_H \times 32 + VBAT\_READ\_L/8)$ .
[2:0]	Not used	R		Not used.

Table 55. FUEL\_GAUGE\_MODE, Register Address 0x24 Bit Descriptions

Bit No.	Mnemonic	Access	Default	Description
[7:2]	Not used	R		Not used.
2	SLEEP_UPDATE_TIME	R/W	0	Select SOC update time in sleep mode. 0: 5 min. 1: 20 min.
1	FUEL_GAUGE_MODE	R/W	0	Fuel gauge operation mode. 1: enable sleep mode. 0: disable sleep mode.
0	FUEL_GAUGE_ENABLE	R/W	0	0: disable fuel gauge. 1: enable fuel gauge.

Table 56. SOC\_RESET, Register Address 0x25 Bit Descriptions

Bit No.	Mnemonic	Access	Default	Description
7	SOC reset	W	0	Write 1 to reset the BAT_SOC, VBAT_READ_H, and VBAT_READ_L registers.
[6:0]	Not used	R		Not used.

Table 57. BST\_LED\_CTRL, Register Address 0x26 Bit Descriptions

Bit No.	Mnemonic	Access	Default	Description
[7:6]	Not used	R		Not used.
5	EN_BST	R/W	0	Boost enable signal (only effective when the boost regulator is in standalone operation mode). 0 = disable boost output. 1 = enable boost output.
4	EN_LED5	R/W	0	Enable signal for LED5 individual sink (not effective if LED5 is configured as the grouped backlight). 0 = disable individual LED5 current sink. 1 = enable individual LED5 current sink.
3	EN_LED4	R/W	0	Enable signal for LED4 individual sink (not effective if LED4 is configured as the grouped backlight). 0 = disable individual LED4 current sink. 1 = enable individual LED4 current sink.
2	EN_LED3	R/W	0	Enable signal for LED3 individual sink (not effective if LED3 is configured as the grouped backlight). 0 = disable individual LED3 current sink. 1 = enable individual LED3 current sink.
1	EN_LED2	R/W	0	Enable signal for LED2 individual sink (not effective if LED2 is configured as the grouped backlight). 0 = disable individual LED2 current sink. 1 = enable individual LED2 current sink.

Bit No.	Mnemonic	Access	Default	Description
0	EN_BL	R/W	0	The grouped backlight enable signal. 0 = disable the grouped backlight. 1 = enable the grouped backlight.

Table 58. BST\_CFG, Register Address 0x27 Bit Descriptions

Bit No.	Mnemonic	Access	Default	Description
7	BST_MODE	R/W	0	This bit sets the boost regulator operation mode. 0 = LED operation mode. 1 = boost standalone operation mode.
6	BST_BL	R/W	0	This bit configures the boost regulator to provide the bias voltage to all active LED channels or only to the active LED backlight channels. (effective only when the boost regulator is configured in LED operation mode). 0 = set the boost regulator to provide the bias voltage for all active LED channels. In this configuration, the boost regulator provides the adaptive headroom regulation according to all active LED current sources. 1 = set the boost regulator to provide the bias voltage only to the active LED backlight channels.
5	FOVR	R/W	0	This bit configures the override feature in the backlight fade in and fade out. 0 = the fade in and fade out override is disabled. 1 = the fade in and fade out override is enabled.
4	Not used	R		Not used.
[3:2]	BST_OVP	R/W	00	This bit sets the overvoltage threshold in the boost output voltage in VOUT4 pin. 00 = 18.5 V. 01 = 15 V. 10 = 10 V. 11 = 5.6 V.
1	Not used	R		Not used.
0	BST_IPK	R/W	0	This bit sets the peak current limit for boost regulator. 0 = 600 mA peak current limit. 1 = 300 mA peak current limit.

Table 59. IBL\_SET, Register Address 0x28 Bit Descriptions

Bit No.	Mnemonic	Access	Default	Description
[7:6]	Not used	R		Not used.
[5:0]	IBL[5:0]	R/W	000000	These bits set the LED current setting for the grouped backlight (LED1). All grouped backlight LED channels follow this current setting. A square law algorithm for 64 levels is used. 000000 = 0 mA. 000001 = 0.005 mA. 000010 = 0.020 mA. ... 111101 = 18.750 mA. 111110 = 19.370 mA. 111111 = 20 mA.

Table 60. ILED2\_SET, Register Address 0x29 Bit Descriptions

Bit No.	Mnemonic	Access	Default	Description
7	BL_LED2	R/W	0	This bit sets LED2 as the grouped backlight or individual current sink. 0 = set as individual current sink. 1 = set as grouped backlight.
6	Not used	R		Not used.
[5:0]	ILED2[5:0]	R/W	000000	These bits set the individual LED current setting for LED2. This setting is not effective if LED2 is configured as the grouped LED backlight. A square law algorithm for 64 levels is used. 000000 = 0 mA. 000001 = 0.005 mA. 000010 = 0.020 mA. ... 111101 = 18.750 mA. 111110 = 19.370 mA. 111111 = 20 mA.

Table 61. ILED3\_SET, Register Address 0x2A Bit Descriptions

Bit No.	Mnemonic	Access	Default	Description
7	BL_LED3	R/W	0	This bit sets LED3 as the grouped backlight or individual current sink. 0 = set as individual current sink. 1 = set as grouped backlight.
6	Not used	R		Not used.
[5:0]	ILED3[5:0]	R/W	000000	Those bits set the individual LED current setting for LED3. This setting is not effective if LED3 is configured as the grouped LED backlight. A square law algorithm for 64 levels is used. 000000 = 0 mA. 000001 = 0.005 mA. 000010 = 0.020 mA. ... 111101 = 18.750 mA. 111110 = 19.370 mA. 111111 = 20 mA.

Table 62. ILED4\_SET, Register Address 0x2B Bit Descriptions

Bit No.	Mnemonic	Access	Default	Description
7	BL_LED4	R/W	0	This bit sets LED4 as the grouped backlight or individual current sink. 0 = set as individual current sink. 1 = set as grouped backlight.
6	Not used	R		Not used.
[5:0]	ILED4[5:0]	R/W	000000	Those bits set the individual LED current setting for LED4. This setting is not effective if LED4 is configured as the grouped LED backlight. A square law algorithm for 64 levels is used. 000000 = 0 mA. 000001 = 0.005 mA. 000010 = 0.020 mA. ... 111101 = 18.750 mA. 111110 = 19.370 mA. 111111 = 20 mA.

Table 63. ILED5\_SET, Register Address 0x2C Bit Descriptions

Bit No.	Mnemonic	Access	Default	Description
7	BL_LED5	R/W	0	This bit sets LED5 as the grouped backlight or individual current sink. 0 = set as individual current sink. 1 = set as grouped backlight.
6	Not used	R		Not used.
[5:0]	ILED5[5:0]	R/W	000000	Those bits set the individual LED current setting for LED5. This setting is not effective if LED5 is configured as the grouped LED backlight. A square law algorithm for 64 levels is used. 000000 = 0 mA. 000001 = 0.005 mA. 000010 = 0.020 mA. ... 111101 = 18.750 mA. 111110 = 19.370 mA. 111111 = 20 mA.

Table 64. BL\_FR, Register Address 0x2D Bit Descriptions

Bit No.	Mnemonic	Access	Default	Description
[7:4]	BL_FO[3:0]	R/W	0000	These bits set the fade out timer for the grouped LED backlight. The timer setting applies to the specific time starting from the maximum LED current code fade out to zero. Therefore, the real fade out time is shorter if the maximum LED current code is not being used. 0000 = fade-out disabled. 0001 = 0.3 sec. 0010 = 0.6 sec. ... 1101 = 3.9 sec. 1110 = 4.2 sec. 1111 = 4.5 sec.
[3:0]	BL_FI[3:0]	R/W	0000	These bits set the fade in timer for the grouped LED backlight. The timer setting applies to the specific time starting from zero fading into the maximum LED current code. Therefore, the real fade in time is shorter if the maximum LED current code is not being used. 0000 = fade in disabled. 0001 = 0.3 sec. 0010 = 0.6 sec. ... 1101 = 3.9 sec. 1110 = 4.2 sec. 1111 = 4.5 sec.

Table 65. LED3\_BLINK, Register Address 0x2E Bit Descriptions

Bit No.	Mnemonic	Access	Default	Description
[7:4]	LED3_OFF[3:0]	R/W	0000	These bits set the off timer for the LED3 blinking feature (not effective if this LED channel is configured as the grouped LED backlight). 0000 = the blinking feature is disabled. 0001 = 0.250 sec. 0010 = 0.500 sec. 0011 = 0.750 sec. ... 1110 = 3.500 sec. 1111 = 3.750 sec.

Bit No.	Mnemonic	Access	Default	Description
[3:0]	LED3_ON[3:0]	R/W	0000	These bits set the on timer for the LED3 blinking feature (not effective if this LED channel is configured as the grouped LED backlight). 0000 = 0.125 sec. 0000 = 0.250 sec. 0010 = 0.375 sec. ... 1110 = 1.875 sec. 1111 = 2.000 sec.

Table 66. LED4\_Blink, Register Address 0x2F Bit Descriptions

Bit No.	Mnemonic	Access	Default	Description
[7:4]	LED4_OFF[3:0]	R/W	0000	These bits set the off timer for the LED4 blinking feature (not effective if this LED channel is configured as the grouped LED backlight). 0000 = the blinking feature is disabled. 0001 = 0.250 sec. 0010 = 0.500 sec. 0011 = 0.750 sec. ... 1110 = 3.500 sec. 1111 = 3.750 sec.
[3:0]	LED4_ON[3:0]	R/W	0000	These bits set the on timer for the LED4 blinking feature (not effective if this LED channel is configured as the grouped LED backlight). 0000 = 0.125 sec. 0000 = 0.250 sec. 0010 = 0.375 sec. ... 1110 = 1.875 sec. 1111 = 2.000 sec.

Table 67. LED5\_Blink, Register Address 0x30 Bit Descriptions

Bit No.	Mnemonic	Access	Default	Description
[7:4]	LED5_OFF[3:0]	R/W	0000	These bits set the off timer for the LED4 blinking feature (not effective if this LED channel is configured as the grouped LED backlight). 0000 = the blinking feature is disabled. 0001 = 0.250 sec. 0010 = 0.500 sec. 0011 = 0.750 sec. ... 1110 = 3.500 sec. 1111 = 3.750 sec.
[3:0]	LED5_ON[3:0]	R/W	0000	These bits set the on timer for the LED5 blinking feature (not effective if this LED channel is configured as the grouped LED backlight). 0000 = 0.125 sec. 0000 = 0.250 sec. 0010 = 0.375 sec. ... 1110 = 1.875 sec. 1111 = 2.000 sec.

Table 68. LED\_STATUS, Register Address 0x31 Bit Descriptions

Bit No.	Mnemonic	Access	Default	Description
[7:5]	Not used	R		Not used.
4	LED5_OPEN <sup>1</sup>	R	Not applicable	This bit records the LED5 status 0: LED5 channel is not open 1: LED5 channel is open
3	LED4_OPEN <sup>1</sup>	R	Not applicable	This bit records the LED4 status 0: LED4 channel is not open 1: LED4 channel is open
2	LED3_OPEN <sup>1</sup>	R	Not applicable	This bit records the LED3 status 0: LED3 channel is not open 1: LED3 channel is open
1	LED2_OPEN <sup>1</sup>	R	Not applicable	This bit records the LED2 status 0: LED2 channel is not open 1: LED2 channel is open
0	LED1_OPEN <sup>1</sup>	R	Not applicable	This bit records the LED1 status 0: LED1 channel is not open 1: LED1 channel is open

<sup>1</sup> To reset any bit in this register, power cycle VBUSx or write the corresponding I<sup>2</sup>C bit high.

Table 69. LDO\_CTRL, Register Address 0x32 Bit Descriptions

Bit No.	Mnemonic	Access	Default	Description
[7:3]	Not used	R		Not used.
2	EN_LDO3	R/W	Factory setting	Enable signal for LDO3 (or Load Switch 3) 0 = disable LDO3 (or Load Switch 3) 1 = enable LDO3 (or Load Switch 3)
1	EN_LDO2	R/W	Factory setting	Enable signal for LDO2 (or Load Switch 2) 0 = disable LDO2 (or Load Switch 2) 1 = enable LDO2 (or Load Switch 2)
0	EN_LDO1	R/W	1	Enable signal for LDO1 (or Load Switch 1) 0 = disable LDO1 (or Load Switch 1) 1 = enable LDO1 (or Load Switch 1)

Table 70. LDO\_CFG, Register Address 0x33 Bit Descriptions

Bit No.	Mnemonic	Access	Default	Description
7	Not used	R		Not used.
6	DSCG_LDO3	R/W	0	This bit configures the output discharge functionality for LDO3 or Load Switch 3 0 = discharge functionality disabled 1 = discharge functionality enabled
5	DSCG_LDO2	R/W	0	This bit configures the output discharge functionality for LDO2 or Load Switch 2 0 = discharge functionality disabled 1 = discharge functionality enabled
4	DSCG_LDO1	R/W	0	This bit configures the output discharge functionality for LDO1 or Load Switch 1 0 = discharge functionality disabled 1 = discharge functionality enabled
3	Not used	R		Not used.
2	MODE_LDO3	R/W	0	This bit sets LDO3 as an LDO or load switch 0 = LDO mode 1 = load switch mode
1	MODE_LDO2	R/W	0	This bit sets LDO2 as an LDO or load switch 0 = LDO mode 1 = load switch mode

Bit No.	Mnemonic	Access	Default	Description
0	MODE_LDO1	R/W	0	This bit sets LDO1 as an LDO or load switch 0 = LDO mode 1 = load switch mode

Table 71. VID\_LDO12, Register Address 0x34 Bit Descriptions

Bit No.	Mnemonic	Access	Default	Description
[7:4]	VID_LDO2	R/W	Factory setting	These bits set the output voltage in LDO2. These bits have no effect when this channel is set as a load switch. 0000 = 4.20 V. 0001 = 3.60 V. 0010 = 3.30 V. 0011 = 3.15 V. 0100 = 3.00 V. 0101 = 2.85 V. 0110 = 2.50 V. 0111 = 2.30 V. 1000 = 2.10 V. 1001 = 1.80 V. 1010 = 1.50 V. 1011 = 1.40 V. 1100 = 1.30 V. 1101 = 1.20 V. 1110 = 1.10 V. 1111 = 1.00 V.
[3:0]	VID_LDO1	R/W	Factory setting	These bits set the output voltage in LDO1. These bits have no effect when this channel is set as a load switch. 0000 = 4.20 V. 0001 = 3.60 V. 0010 = 3.30 V. 0011 = 3.15 V. 0100 = 3.00 V. 0101 = 2.85 V. 0110 = 2.50 V. 0111 = 2.30 V. 1000 = 2.10 V. 1001 = 1.80 V. 1010 = 1.50 V. 1011 = 1.40 V. 1100 = 1.30 V. 1101 = 1.20 V. 1110 = 1.10 V. 1111 = 1.00 V.

Table 72. VID\_LDO3, Register Address 0x35 Bit Descriptions

Bit No.	Mnemonic	Access	Default	Description
[7:4]	Not used	R		Not used.
[3:0]	VID_LDO3	R/W	Factory setting	These bits set the output voltage in LDO3. These bits have no effect when this channel is set as a load switch. 0000 = 4.20 V. 0001 = 3.60 V. 0010 = 3.30 V. 0011 = 3.15 V. 0100 = 3.00 V. 0101 = 2.85 V. 0110 = 2.50 V. 0111 = 2.30 V. 1000 = 2.10 V. 1001 = 1.80 V. 1010 = 1.50 V. 1011 = 1.40 V. 1100 = 1.30 V. 1101 = 1.20 V. 1110 = 1.10 V. 1111 = 1.00 V.

Table 73. PGOOD\_STATUS, Register Address 0x36 Bit Descriptions

Bit No.	Mnemonic	Access	Default	Description
[7:4]	Not used	R		Not used.
3	VBUSOK	R	Not applicable	This bit shows real-time status of VBUSx voltage. 0 = the voltage at the VBUSx pin is below $V_{VBUSOK}$ or above $V_{VBUS\_OV}$ . 1 = the voltage at the VBUSx pin is above $V_{VBUSOK}$ and below $V_{VBUS\_OV}$ .
2	BATOK	R	Not applicable	This bit shows the real-time status of the battery voltage. 0 = battery voltage is lower than $V_{WEAK}$ . 1 = battery voltage is higher than $V_{WEAK}$ .
1	PG4_BST	R	Not applicable	This bit shows the real-time power-good status for the boost regulator. This bit is effective only in boost standalone fixed output mode. 0 = boost regulator power-good status is low. 1 = boost regulator power-good status is high.
0	PG1_LDO1	R	Not applicable	This bit shows the real-time power good status for LDO1. This bit is not effective if the LDO regulator is configured as a load switch mode. 0 = LDO1 power-good status is low. 1 = LDO1 power-good status is high.

Table 74. PGOOD\_MASK, Register Address 0x37 Bit Descriptions

Bit No.	Mnemonic	Access	Default	Description
[7:4]	Not used	R		Not used.
3	VBUSOK_MASK	R/W	Factory setting	This bit configures the external PGOOD pin. 0 = do not output the $V_{VBUSx}$ voltage status signal to the external PGOOD pin. 1 = output $V_{BUS}$ voltage status signal to the external PGOOD pin.
2	BATOK_MASK	R/W	0	This bit configures the external PGOOD pin. 0 = do not output BATOK signal to the external PGOOD pin. 1 = output the BATOK signal to the external PGOOD pin.

Bit No.	Mnemonic	Access	Default	Description
1	PG4_BST_MASK	R/W	0	This bit configures the external PGOOD pin. This bit is only effective in boost standalone fixed output mode. 0 = do not output the boost PGOOD signal to the external PGOOD pin. 1 = output the boost PGOOD signal to the external PGOOD pin.
0	PG1_LDO1_MASK <sup>1</sup>	R/W	Factory setting	This bit configures the external PGOOD pin. This bit is not effective if the LDO regulator is configured as a load switch mode. 0 = do not output the LDO1 PGOOD signal to the external PGOOD pin. 1 = output the LDO1 PGOOD signal to the external PGOOD pin.

<sup>1</sup> When the PGOOD pin is selected for PG1\_LDO1\_MASK, the ADP5350 quiescent current increases to 4  $\mu$ A typically.

**Table 75. CHARGER\_INTERRUPT\_ENABLE, Register Address 0x38 Bit Descriptions**

Bit No.	Mnemonic	Access	Default	Description
7	EN_IND_PEAK_INT	R/W	0	When high, the inductor peak current-limit interrupt is enabled.
6	EN_THERM_LIM_INT	R/W	0	When high, the isothermal charging interrupt is allowed.
5	EN_WD_INT	R/W	0	When high, the watchdog alarm interrupt is allowed.
4	EN_TSD_INT	R/W	0	When high, the overtemperature 130°C warning interrupt is allowed.
3	EN_THR_INT	R/W	0	When high, the THR temperature thresholds interrupt is allowed.
2	EN_BAT_INT	R/W	0	When high, the battery voltage thresholds interrupt is allowed.
1	EN_CHG_INT	R/W	0	When high, the charger mode change interrupt is allowed.
0	EN_VIN_INT	R/W	0	When high, the VBUSx pin voltage thresholds interrupt is allowed.

**Table 76. CHARGER\_INTERRUPT\_FLAG, Register Address 0x39 Bit Descriptions**

Bit No.	Mnemonic	Access	Default	Description
7	IND_PEAK_INT <sup>1</sup>	R	0	When high, this bit indicates an interrupt caused by an inductor peak current limit.
6	THERM_LIM_INT <sup>1</sup>	R	0	When high, this bit indicates an interrupt caused by isothermal charging.
5	WD_INT <sup>1</sup>	R	0	When high, this bit indicates an interrupt caused by the watchdog alarm. The watchdog timer expires within 2 sec or 4 sec depending on the $t_{WD}$ setting of 32 sec or 64 sec, respectively.
4	TSD_INT <sup>1</sup>	R	0	When high, this bit indicates an interrupt caused by an overtemperature fault.
3	THR_INT <sup>1</sup>	R	0	When high, this bit indicates an interrupt caused by THR temperature thresholds.
2	BAT_INT <sup>1</sup>	R	0	When high, this bit indicates an interrupt caused by battery voltage thresholds.
1	CHG_INT <sup>1</sup>	R	0	When high, this bit indicates an interrupt caused by a charger mode change.
0	VIN_INT <sup>1</sup>	R	0	When high, this bit indicates an interrupt caused by VBUSx voltage thresholds.

<sup>1</sup> These bits reset to 0 automatically when read.

**Table 77. BOOST\_LDO\_INTERRUPT\_ENABLE, Register Address 0x3A Bit Descriptions**

Bit No.	Mnemonic	Access	Default	Description
[7:3]	Not used	R		Not used.
2	EN_LED_OPEN_INT	R/W	0	0 = LED open events does not trigger the interrupt pin. 1 = LED open events triggers the interrupt pin.
1	EN_PG4_BST_INT	R/W	0	0 = power-good warning on the boost regulator does not trigger the interrupt pin. 1 = power-good warning on the boost regulator triggers the interrupt pin.
0	EN_PG1_LDO1_INT	R/W	0	0 = power-good warning on LDO1 does not trigger the interrupt pin. 1 = power-good warning on LDO1 triggers the interrupt pin.

Table 78. BOOST\_LDO\_INTERRUPT\_FLAG, Register Address 0x3B Bit Descriptions

Bit No.	Mnemonic	Access	Default	Description
[7:3]	Not used	R		Not used.
2	LED_OPEN_INT <sup>1</sup>	R	0	When high, this bit indicates an interrupt caused by LED open-circuit faults.
1	PG4_BST_INT <sup>1</sup>	R	0	When high, this bit indicates an interrupt caused by a power-good warning on the boost regulator.
0	PG1_LDO1_INT <sup>1</sup>	R	0	When high, this bit indicates an interrupt caused by a power-good warning on LDO1.

<sup>1</sup> These bits reset to 0 automatically when read.

Table 79. DEFAULT\_SET, Register Address 0x3C Bit Descriptions

Bit No.	Mnemonic	Access	Default	Description
[7:0]	DEFAULT_SET	W	0	Write 0x7F to this bit to reset all register to default values.

Table 80. NTC47K\_SET, Register Address 0x3D Bit Descriptions

Bit No.	Mnemonic	Access	Default	Description
[7:1]	Not used	R		Not used.
0	NTC_47K	R/W	1	Select battery thermistor NTC resistance, effective when R_NTC = 1. 0 = 100 kΩ at 25°C. 1 = 47 kΩ at 25°C.

## APPLICATIONS INFORMATION

### EXTERNAL COMPONENTS

#### Buck Inductor Selection

The high switching frequency of the [ADP5350](#) buck converter allows the selection of small chip inductors. Suggested buck inductors are shown in Table 81.

The peak-to-peak inductor current ripple,  $I_{RIPPLE}$ , is calculated using the following equation:

$$I_{RIPPLE} = \frac{V_{ISOS} \times (V_{ISOS} - V_{CFL1})}{V_{ISOS} \times f_{SW} \times L1}$$

where:

$V_{ISOS}$  is the ISOS node output voltage.

$V_{CFL1}$  is the converter input voltage at the CFL1 node.

$f_{SW}$  is the switching frequency.

$L1$  is the buck output inductor value.

The minimum dc current rating of the inductor must be greater than the inductor peak current. The inductor peak current,  $I_{PEAK}$ , is calculated using the following equation:

$$I_{PEAK} = I_{CHG} + I_{LOAD\_MAX} + \frac{I_{RIPPLE}}{2}$$

Inductor conduction losses are caused by the flow of current through the inductor, which has an associated internal dc resistance (DCR). Larger inductors have smaller DCR values, which may decrease inductor conduction losses. Inductor core losses are related to the magnetic permeability of the core material. Because the buck regulators are high switching frequency dc-to-dc converters, shielded ferrite core material is recommended for its low core losses and low electromagnetic interference (EMI).

#### Boost Inductor Selection

The inductor is an essential part of the boost switching regulator. It stores energy during the on time, and transfers that energy to the output through the output rectifier during the off time. Use inductance in the range of 2  $\mu$ H to 10  $\mu$ H. In general, lower inductance values have higher saturation current and lower series resistance for a given physical size. However, lower inductance results in higher peak current that can lead to reduced efficiency and greater input and/or output ripple and noise. Peak-to-peak inductor ripple current at close to 30% of

**Table 81. Suggested Buck Inductors**

Vendor	Part Number	L ( $\mu$ H)	Typical DC Current (A)	Maximum DCR (m $\Omega$ )	Size
Würth	74479976215	1.5	1.2	125	0806
TDK	VLS201612CX-1R5M	1.5	1.9	89	0806

**Table 82. Suggested Boost Inductors**

Vendor	Part Number	L ( $\mu$ H)	Typical DC Current (A)	Maximum DCR (m $\Omega$ )	Size
Würth	74479776247A	4.7	0.9	140	0806
TDK	VLS201612CX-4R7M	4.7	1.12	252	0806

the maximum dc input current typically yields an optimal compromise. Suggested boost inductors are shown in Table 82.

The input  $V_{IN4}$  and output  $V_{OUT4}$  voltages determine the switch duty cycle, which in turn determine the inductor ripple current. Calculate the inductor ripple current in a steady state using the following equation:

$$I_{RIPPLE4} = \frac{V_{IN4} \times (V_{OUT4} - V_{IN4})}{V_{OUT4} \times f_{SW4} \times L2}$$

Make sure that the peak inductor current, the maximum input current plus half the inductor ripple current is below the rated saturation current of the inductor. Likewise, make sure that the maximum rated rms current of the inductor is greater than the maximum dc input current to the regulator.

#### VBUSx Capacitor Selection

According to the USB 2.0 specification, USB peripherals have a detectable change in capacitance on VBUSx when VBUSx are attached. The peripheral device VBUSx bypass capacitance must be at least 1  $\mu$ F but not larger than 10  $\mu$ F. The combined capacitance for the VBUSx and CFL1 pins must not exceed 10  $\mu$ F at any temperature or dc bias condition. Suggested VBUSx capacitors are shown in Table 83.

#### CFL1 Capacitor Selection

The CFL1 pin serves the [ADP5350](#) as the buck dc-to-dc regulator input capacitor. The rms current rating of the input capacitor current must be larger than the value calculated by the following equation:

$$I_{C\_RMS} = (I_{CHG} + I_{LOAD\_MAX}) \sqrt{\frac{V_{ISOS} \times (V_{CFL1} - V_{ISOS})}{V_{CFL1}}}$$

To minimize supply noise, place the input capacitor as close as possible to the CFL1 pin of the charger. As with the output capacitor, a low ESR capacitor is recommended.

The effective capacitance needed for stability, which includes temperature and dc bias effects, is a minimum of 2  $\mu$ F and a maximum of 7  $\mu$ F. A list of suggested capacitors is shown in Table 84.

### CFL2 Capacitor Selection

The CFL2 pin is the internal regulator output that provides the power supply for post stage control circuits, including the fuel gauge, boost LED, and LDOs. To ensure stable performance of the internal regulator, the recommended components for the CFL2 capacitor are given in Table 85.

### ISOS and ISOB Capacitor Selection

Higher output capacitor values reduce the output voltage ripple and improve load transient response. When choosing this value, it is also important to account for the loss of capacitance due to output voltage dc bias.

To guarantee the performance of the charger in various operation modes, including trickle charge, CC charge, and CV charge, it is imperative that the effects of dc bias, temperature, and tolerances on the behavior of the capacitors be evaluated for each application.

The peak-to-peak output voltage ripple for the selected output capacitor and inductor values is calculated using the following equation:

$$V_{RIPPLE} = \frac{I_{RIPPLE}}{8 \times f_{SW} \times C_{OUT}}$$

Capacitors with lower effective series resistance (ESR) are preferable to guarantee low output voltage ripple, as shown in the following equation:

$$ESR_{COUT} \leq \frac{V_{RIPPLE}}{I_{RIPPLE}}$$

**Table 83. Suggested VBUSx Capacitors**

Vendor	Part Number	Value (µF)	Voltage (V)	Size
Murata	GRM188R61E225K	2.2	25	0603
TDK	C1608X5R1E225	2.2	25	0603

**Table 84. Suggested CFL1 Capacitors**

Vendor	Part Number	Value (µF)	Voltage (V)	Size
Murata	GRM188R60J475K	4.7	6.3	0603
TDK	C1608X5R0J475K	4.7	6.3	0603

**Table 85. Suggested CFL2 Capacitors**

Vendor	Part Number	Value (µF)	Voltage (V)	Size
Murata	GRM188R60J225K	2.2	6.3	0603
TDK	C1608X5R0J475K	2.2	6.3	0603

**Table 86. Suggested ISOS and ISOB Capacitors**

Vendor	Part Number	Value (µF)	Voltage (V)	Size
Murata	GRM188R60J106K	10	6.3	0603
TDK	C1608X5R0J106M080AB	10	6.3	0603

### LDO Capacitor Selection

Connecting a 1 µF capacitor from VIN123 to AGND reduces the circuit sensitivity to the PCB layout, especially when long input traces or high source impedance are encountered.

The ADP5350 is designed for operation with small, space-saving ceramic capacitors, but functions with most commonly used capacitors as long as care is taken with regard to the ESR value. The ESR of the output capacitor affects the stability of the LDO control loop. A minimum of 1 µF capacitance with an ESR of 1 Ω or less is recommended to ensure stability of the ADP5350. Transient response to changes in load current is also affected by output capacitance. Using a larger value of output capacitance improves the transient response of the ADP5350 to large changes in load current.

**Table 87. Suggested LDO Capacitors**

Vendor	Part Number	Value (µF)	Voltage (V)	Size
Murata	GRM155R60J105KE19D	1	6.3	0402
TDK	CGB2A3X5R0J105M033BB	1	6.3	0402

### Boost Capacitor Selection

The ADP5350 requires input and output decoupling capacitors to supply transient currents while maintaining a constant input and output voltage. Use a low ESR input capacitor, 4.7 µF or greater, to prevent noise at the VIN4 node. Place the capacitor between the VIN4 pin and PGND4 as close to the ADP5350 as possible. Ceramic capacitors are preferred because of their low ESR characteristics.

The output capacitor maintains the output voltage and supplies current to the load while the boost switch is on. The value and characteristics of the output capacitor greatly affect the output voltage ripple and stability of the regulator. Use a low ESR output capacitor; ceramic dielectric capacitors are preferred.

For very low ESR capacitors, such as ceramic capacitors, the ripple current due to the capacitance is calculated as follows. Because the capacitor discharges during the on time the charge removed from the capacitor is the load current multiplied by the on time. Choose the output capacitor based on the following equation:

$$C_{OUT4} \geq \frac{I_{L2} \times (V_{OUT4} - V_{IN4})}{f_{SW4} \times V_{OUT4} \times V_{RIPPLE4}}$$

where:

$I_{L2}$  is the average inductor current.

$V_{RIPPLE4}$  is boost output voltage ripple.

**Table 88. Suggested Boost Capacitors**

Vendor	Part Number	Value (µF)	Voltage (V)	Size
Murata	GRM188R61C475ME11	4.7	25	0603
TDK	C1608X5R1E475M080AC	4.7	25	0603
Murata	GRM188R61E106MA73	10	25	0603
TDK	C1608X5R1E106M080AC	10	25	0603

**PCB LAYOUT GUIDELINES**

Poor layout can affect ADP5350 performance, causing EMI and electromagnetic compatibility (EMC) problems, ground bounce, and voltage losses. Poor layout can also affect regulation and stability. A good layout is implemented using the following guidelines:

- Place the decoupling capacitor, inductor, input capacitor, and output capacitor close to the IC.

- Use a ground plane with several vias connecting to the component side ground to further reduce noise interference on sensitive circuit nodes.
- Use a dedicated trace to connect the BSNS pin to the battery pack output node for accurate sensing of the battery voltage.
- Use Size 0603 or Size 0402 resistors and capacitors to achieve the smallest possible footprint solution on boards where space is limited.

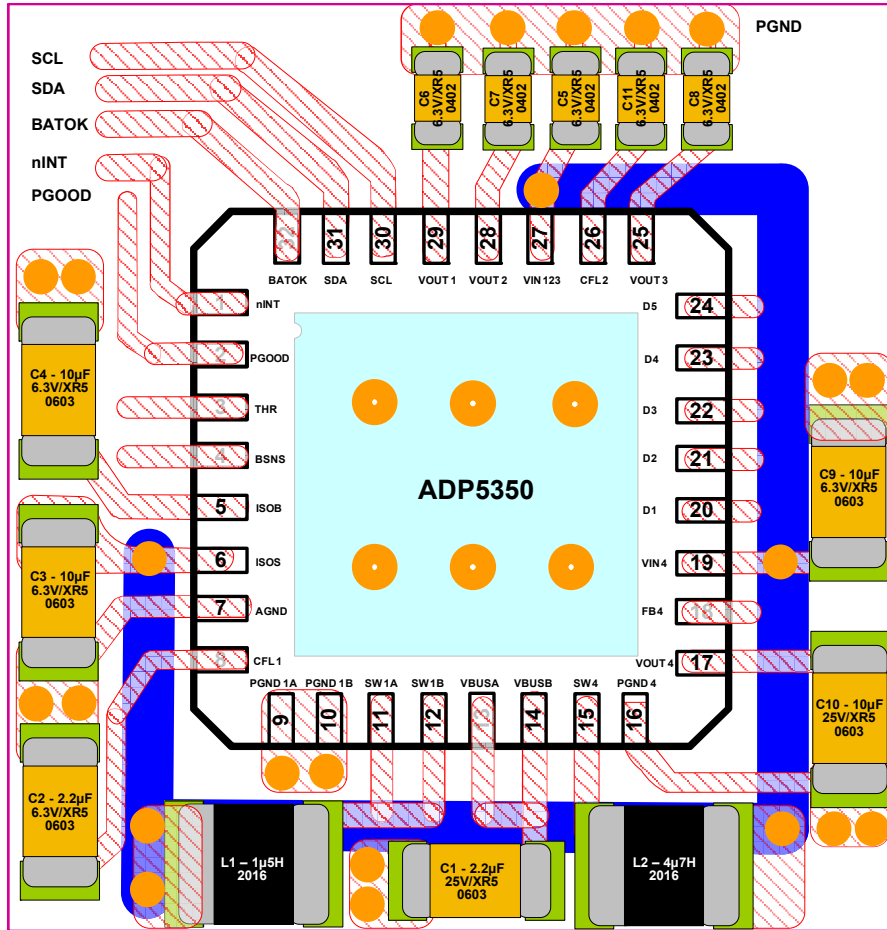

Figure 59. Recommended Layout

14797-043

TYPICAL APPLICATION CIRCUITS

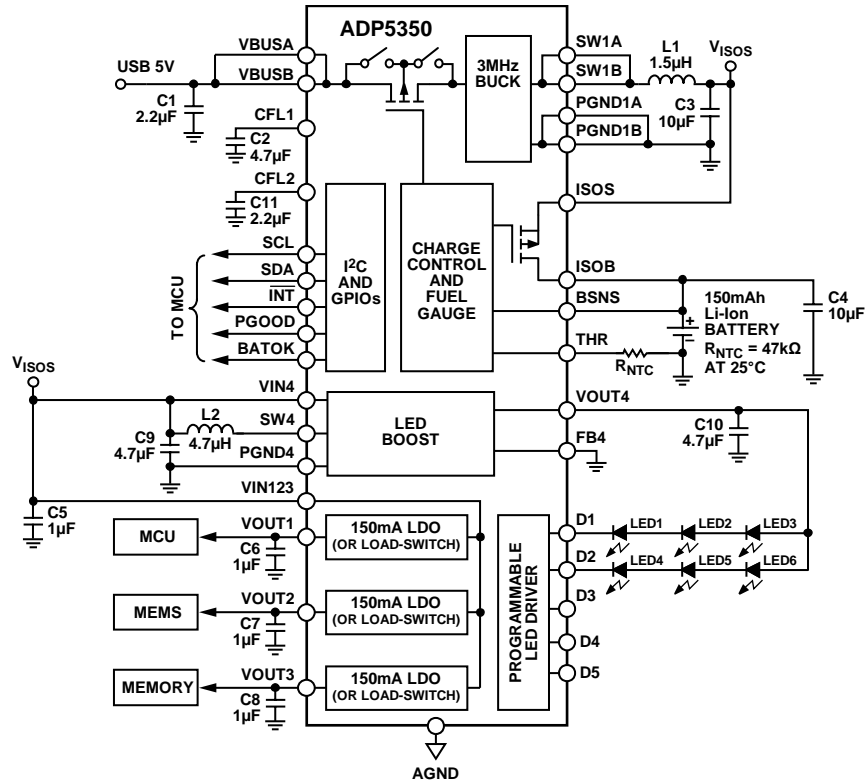

Figure 60. Li-Ion Battery Charger Application with LED Panel

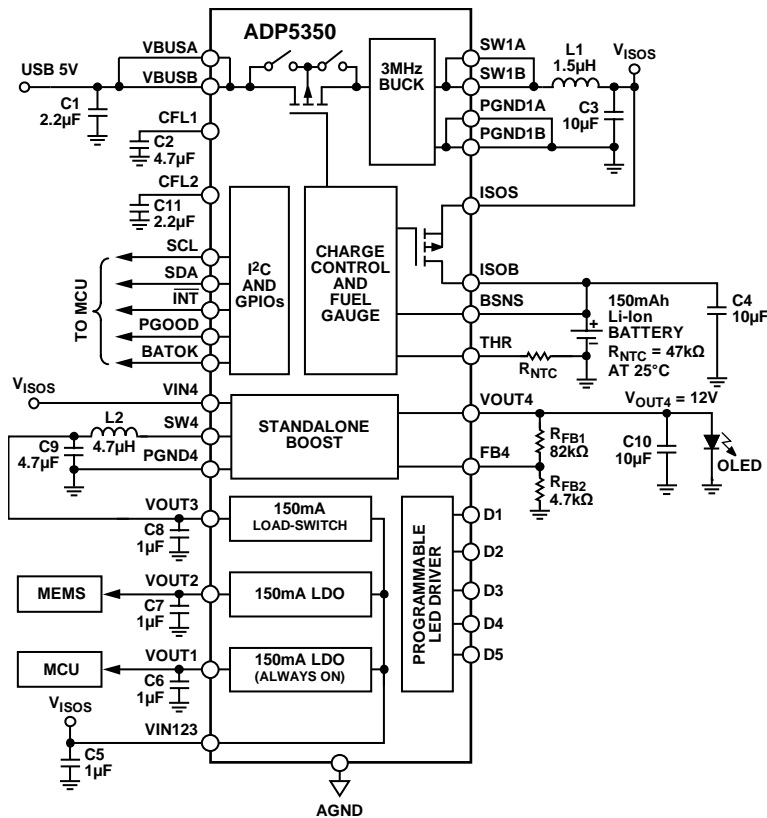

Figure 61. True Shutdown Standalone Boost for OLED Panel Application

14797-044

14797-045

## FACTORY-PROGRAMMABLE OPTIONS

Table 89. Fuse-Programmable Trim Options for the [ADP5350](#)

Parameter	Value	Default Setting
I <sup>2</sup> C Address	0x44 0x45 0x64 0x65	0x44
R_NTC	10 kΩ 100 kΩ/47 kΩ	100 kΩ/47 kΩ
BETA_NTC	2350 2600 2750 3000 3150 3350 3500 3600 3800 4000 4200 4400 4600 4800 5000 5200	3800
EN_CHG	Charger is enabled Charger is disabled	Charger is disabled
EN_LDO2	LDO2 is enabled LDO2 is disabled	LDO2 is disabled
EN_LDO3	LDO3 is enabled LDO3 is disabled	LDO3 is disabled
VID_LDO1, VID_LDO2, VID_LDO3	4.20 V 3.60 V 3.30 V 3.15 V 3.00 V 2.85 V 2.50 V 2.30 V 2.10 V 1.80 V 1.50 V 1.40 V 1.30 V 1.20 V 1.10 V 1.00 V	3.3 V
VBUSOK_MASK	Do not output the V <sub>VBUSx</sub> voltage status signal to the external PGOOD pin Output the V <sub>VBUSx</sub> voltage status signal to external PGOOD pin	Output the V <sub>VBUSx</sub> voltage status signal to the external PGOOD pin
PG1_LDO1_MASK	Do not output the LDO1 PGOOD signal to the external PGOOD pin Output the LDO1 PGOOD signal to external PGOOD pin	Do not output the LDO1 PGOOD signal to the external PGOOD pin

OUTLINE DIMENSIONS

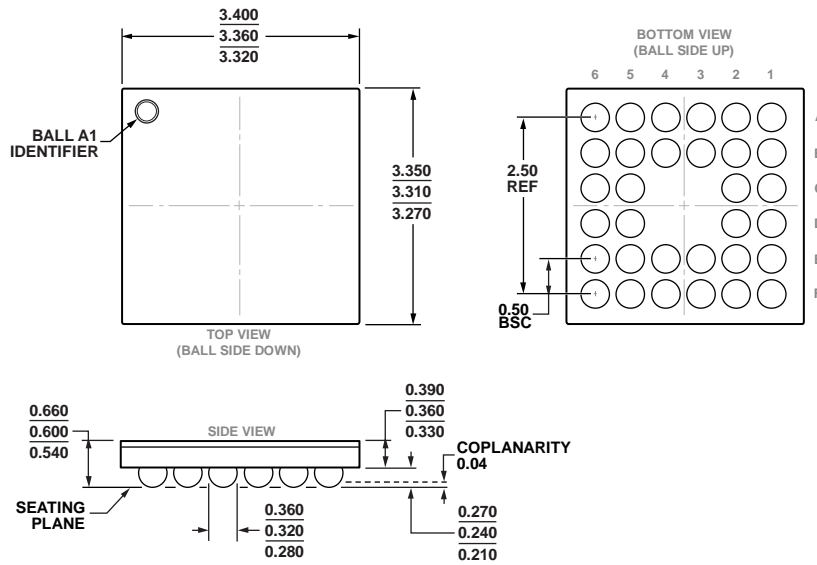
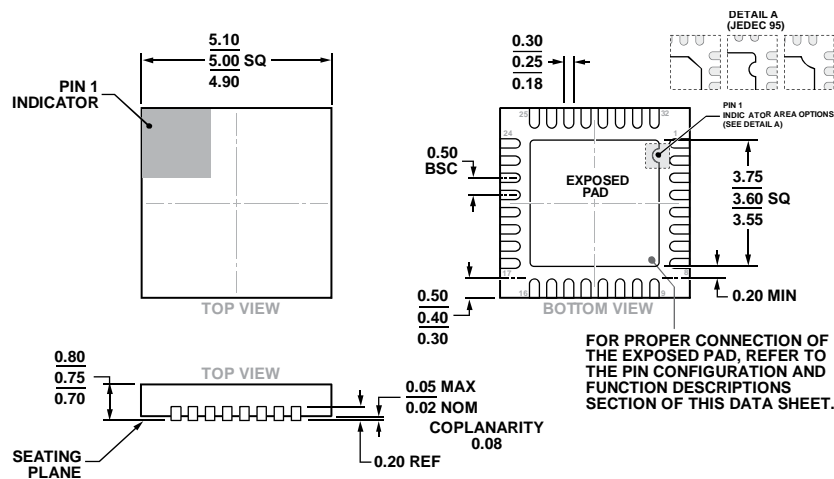

Figure 62. 32-Ball Wafer Level Chip Scale Package [WLCSP] (CB-32-1)  
Dimensions shown in millimeters



COMPLIANT TO JEDEC STANDARDS MO-220-WHHD-5  
Figure 63. 32-Lead Lead Frame Chip Scale Package [LF CSP] 5 mm x 5 mm Body and 0.75 mm Package Height (CP-32-12)  
Dimensions shown in millimeters

ORDERING GUIDE

Model <sup>1</sup>	Temperature Range	Package Description	Package Option
ADP5350ACBZ-1-R7	-40°C to +125°C	32-Ball Wafer Level Chip Scale Package [WLCSP]	CB-32-1
ADP5350ACPZ-1-R7	-40°C to +125°C	32-Lead Lead Frame Chip Scale Package [LF CSP]	CP-32-12
ADP5350CB-EVALZ		Evaluation Board	
ADP5350CP-EVALZ		Evaluation Board	

<sup>1</sup> Z = RoHS Compliant Part.

## Looking for pricing, stock, or lifecycle information?

Click below to explore more details on WIN SOURCE:

- ⊖ [View ADP5350ACPZ-1-R7 on WIN SOURCE](#)
- ⊖ [Analog Devices Inc. Information](#)

## Optimize Your Supply Chain with WIN SOURCE Solutions

- ✓ Global Sourcing Solution
- ✓ Obsolete Management
- ✓ Cost Control Management
- ✓ Shortage Management
- ✓ Alternative Solution
- ✓ Excess Inventory Management