



**THE DATASHEET OF
ADAU1777BCBZRL**



FEATURES

- Programmable audio processing engine
 - Fast (up to 768 kHz) and slow processing paths
 - Biquad filters, limiters, volume controls, and mixing
- Low latency, 24-bit ADCs and DACs
 - 102 dB SNR (through PGA and ADC with A weighted filter)
 - 108 dB combined SNR (through DAC and headphone with A weighted filter)
- Serial port sampling rate from 8 kHz to 192 kHz
- 5 μ s analog-to-analog latency
- 4 single-ended analog inputs, configurable as microphone or line inputs
- Dual stereo digital microphone inputs
- Stereo analog audio output, single-ended or differential, configurable as either line output or headphone driver
- PLL supporting any input clock rate from 8 MHz to 27 MHz
- Full duplex, asynchronous sample rate converters (ASRCs)
- Power supplies
 - Analog and digital input/output of 1.8 V to 3.3 V
 - Digital signal processing (DSP) core of 1.1 V to 1.8 V
- Low power
- I²C and SPI control interfaces, self boot from I²C EEPROM
- 7 multipurpose (MPx) pins for digital controls and outputs

APPLICATIONS

- Noise canceling handsets, headsets, and headphones
- Bluetooth[®] active noise canceling (ANC) handsets, headsets, and headphones
- Personal navigation devices
- Digital still and video cameras

GENERAL DESCRIPTION

The ADAU1777 is a codec with four inputs and two outputs that incorporates a digital processing engine to perform filtering, level control, signal level monitoring, and mixing. The path from the analog input to the DSP core to the analog output is optimized for low latency and is ideal for noise canceling headsets. With the addition of just a few passive components, a crystal, and an EEPROM for booting, the ADAU1777 provides a complete headset solution.

Note that throughout this data sheet, multifunction pins, such as SCL/SCLK, are referred to either by the entire pin name or by a single function of the pin, for example, SCLK, when only that function is relevant.

FUNCTIONAL BLOCK DIAGRAM

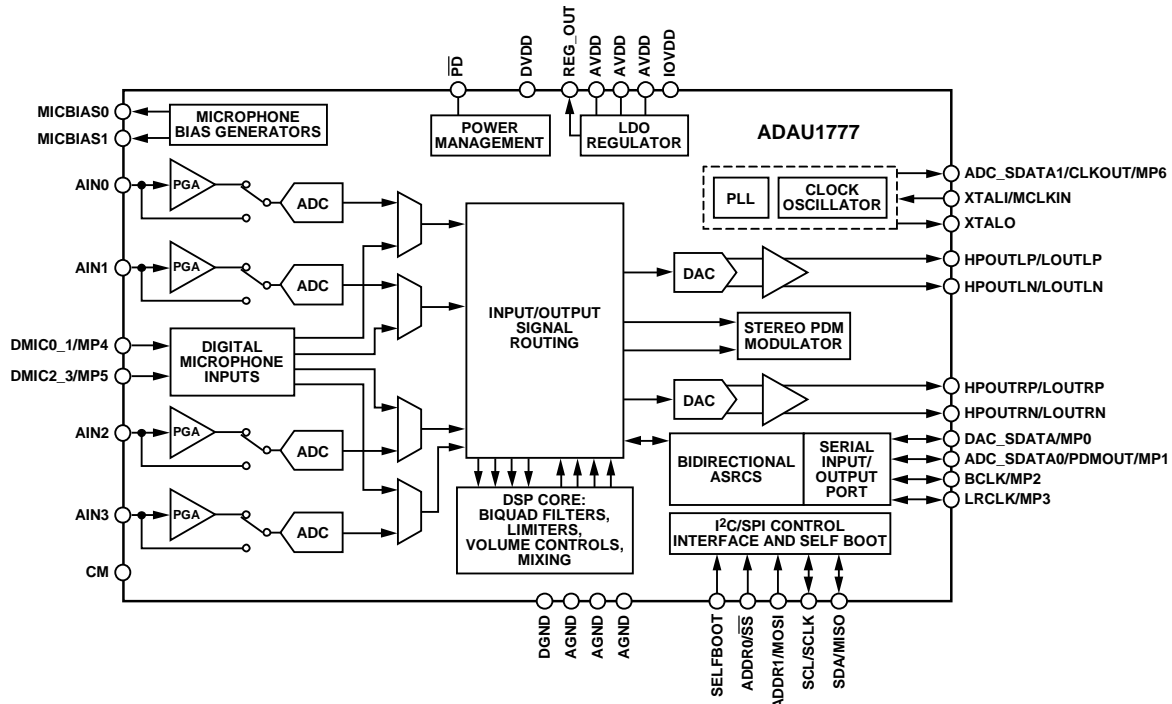

Figure 1.

Rev. 0

[Document Feedback](#)

Information furnished by Analog Devices is believed to be accurate and reliable. However, no responsibility is assumed by Analog Devices for its use, nor for any infringements of patents or other rights of third parties that may result from its use. Specifications subject to change without notice. No license is granted by implication or otherwise under any patent or patent rights of Analog Devices. Trademarks and registered trademarks are the property of their respective owners.

TABLE OF CONTENTS

Features	1	Burst Mode Communication	35
Applications	1	I ² C Port	35
General Description	1	SPI Port	38
Functional Block Diagram	1	Self Boot	39
Revision History	3	Multipurpose Pins	40
Specifications	4	Push-Button Volume Controls	40
Analog Performance Specifications	4	Limiter Compression Enable	40
Crystal Amplifier Specifications	8	Parameter Bank Switching	40
Digital Input/Output Specifications	8	Mute	40
Power Supply Specifications	8	DSP Bypass Mode	41
Typical Power Management Settings	9	Serial Data Input/Output Ports	42
Digital Filters Specifications	9	Tristating Unused Channels	42
Digital Timing Specifications	10	Applications Information	45
Absolute Maximum Ratings	14	Power Supply Bypass Capacitors	45
Thermal Resistance	14	Layout	45
ESD Caution	14	Grounding	45
Pin Configuration and Function Descriptions	15	PCB Stackup	45
Typical Performance Characteristics	17	Low Latency Register Settings	46
Theory of Operation	24	Register Summary	49
System Clocking and Power-Up	25	Register Details	52
Clock Initialization	25	Clock Control Register	52
PLL	25	PLL Denominator MSB Register	53
Clock Output	26	PLL Denominator LSB Register	53
Power Sequencing	26	PLL Numerator MSB Register	53
Signal Routing	27	PLL Numerator LSB Register	54
Input Signal Paths	28	PLL Integer Setting Register	54
Analog Inputs	28	PLL Lock Flag Register	55
Digital Microphone Input	29	CLKOUT Setting Selection Register	55
Analog-to-Digital Converters (ADCs)	29	Regulator Control Register	56
Output Signal Paths	30	Core Control Register	56
Analog Outputs	30	Sleep on Program Address Count Register	57
Digital-to-Analog Converters (DACs)	30	Filter Engine and Limiter Control Register	59
PDM Output	30	DB Value Register 0 Read	59
Asynchronous Sample Rate Converters	31	DB Value Register 1 Read	60
Signal Levels	31	DB Value Register 2 Read	60
Signal Processing	32	Core Channel 0/Core Channel 1 Input Select Register	61
Instructions	32	Core Channel 2/Core Channel 3 Input Select Register	62
Data Memory	32	DAC Input Select Register	63
Parameters	32	PDM Modulator Input Select Register	64
Control Port	35		

Serial Data Output 0/Serial Data Output 1 Input Select Register	65	Serial Port Control 0 Register.....	85
Serial Data Output 2/Serial Data Output 3 Input Select Register	66	Serial Port Control 1 Register.....	86
Serial Data Output 4/Serial Data Output 5 Input Select Register	67	TDM Output Channel Disable Register	87
Serial Data Output 6/Serial Data Output 7 Input Select Register	68	PDM Enable Register	88
ADC_SDATA0/ADC_SDATA1 Channel Select Register.....	69	PDM Pattern Setting Register	89
Output ASRC0/Output ASRC1 Source Register.....	69	MP0 Function Setting Register	89
Output ASRC2/Output ASRC3 Source Register.....	70	MP1 Function Setting Register	90
Input ASRC Channel Select Register	71	MP2 Function Setting Register	91
ADC0/ADC1 Control 0 Register	72	MP3 Function Setting Register	91
ADC2/ADC3 Control 0 Register	73	MP4 Function Setting Register	92
ADC0/ADC1 Control 1 Register	74	MP5 Function Setting Register	93
ADC2/ADC3 Control 1 Register	75	MP6 Function Setting Register	94
ADC0 Volume Control Register	75	Push-Button Volume Settings Register	94
ADC1 Volume Control Register	76	Push-Button Volume Control Assignment Register	95
ADC2 Volume Control Register	76	Debounce Modes Register	96
ADC3 Volume Control Register	77	Headphone Line Output Select Register.....	97
PGA Control 0 Register.....	77	Decimator Power Control Register	97
PGA Control 1 Register.....	78	ASRC Interpolator and DAC Modulator Power Control Register	99
PGA Control 2 Register.....	78	Analog Bias Control 0 Register	99
PGA Control 3 Register.....	79	Analog Bias Control 1 Register	100
PGA Slew Control Register.....	80	Digital Pin Pull-Up Control 0 Register	101
PGA 10 dB Gain Boost Register.....	80	Digital Pin Pull-Up Control 1 Register	102
Input and Output Capacitor Charging Register	81	Digital Pin Pull-Down Control 0 Register	103
DSP Bypass Path Register	82	Digital Pin Pull-Down Control 1 Register	103
DSP Bypass Gain for PGA0 Register	82	Digital Pin Drive Strength Control 0 Register	104
DSP Bypass Gain for PGA1 Register	82	Digital Pin Drive Strength Control 1 Register	105
MICBIAS0_1 Control Register.....	83	Fast Rate Control Register	105
DAC Control Register	83	DAC Interpolation Control Register	106
DAC0 Volume Control Register.....	84	Volume Control Bypass Register	107
DAC1 Volume Control Register.....	84	Outline Dimensions.....	108
Headphone Output Mutes Register	85	Ordering Guide	108

REVISION HISTORY

12/2016—Revision 0: Initial Version

SPECIFICATIONS

Master clock = 12.288 MHz, serial input sample rate = 48 kHz, measurement bandwidth = 20 Hz to 20 kHz, word width = 24 bits, $T_A = 25^\circ\text{C}$, outputs line loaded with 10 k Ω .

ANALOG PERFORMANCE SPECIFICATIONS

AVDD = IOVDD = 1.8 V, DVDD = 1.1 V, unless otherwise noted. Phase-locked loop (PLL) disabled, direct master clock.

Table 1.

Parameter	Test Conditions/Comments	Min	Typ	Max	Unit
ANALOG-TO-DIGITAL CONVERTERS (ADCs)					
ADC Resolution	All ADCs		24		Bits
Digital Attenuation Step			0.375		dB
Digital Attenuation Range			95		dB
INPUT RESISTANCE					
Single-Ended Line Input	Gain settings do not include 10 dB gain from PGA_x_BOOST settings; this additional gain does not affect input impedance; PGA_POP_DISx = 1 0 dB gain		14.3		k Ω
Programmable Gain Amplifier (PGA) Inputs	–12 dB gain		32.0		k Ω
	0 dB gain		20		k Ω
	+35.25 dB gain		0.68		k Ω
LINE INPUT					
Full-Scale Input Voltage	PGA_ENx = 0, PGA_x_BOOST = 0, PGA_POP_DISx = 1 Scales linearly with AVDD AVDD = 1.8 V AVDD = 1.8 V AVDD = 3.3 V AVDD = 3.3 V		AVDD/3.3 0.55 1.54 1.00 2.83		V rms V rms V p-p V rms V p-p
Dynamic Range ¹	20 Hz to 20 kHz, –60 dB input				
With A-Weighted Filter (RMS)	AVDD = 1.8 V	95	97		dB
	AVDD = 3.3 V	99	102		dB
With Flat 20 Hz to 20 kHz Filter	AVDD = 1.8 V	92	94		dB
	AVDD = 3.3 V	96	99		dB
Signal-to-Noise Ratio (SNR) ²					
With A-Weighted Filter (RMS)	AVDD = 1.8 V	96	98		dB
	AVDD = 3.3 V	100	103		dB
With Flat 20 Hz to 20 kHz Filter	AVDD = 1.8 V	92	96		dB
	AVDD = 3.3 V	96	100		dB
Interchannel Gain Mismatch		0	40	200	mdB
Total Harmonic Distortion + Noise (THD + N)	20 Hz to 20 kHz, –1 dB from full-scale input AVDD = 1.8 V AVDD = 3.3 V		–90 –94	–83 –87	dB dB
Offset Error		–0.11		+0.12	mV
Gain Error		–0.4		+0.2	dB
Interchannel Isolation	CM capacitor = 22 μF		95		dB
Power Supply Rejection Ratio (PSRR)	CM capacitor = 22 μF , 100 mV p-p at 1 kHz		55		dB
PGA INPUT					
Full-Scale Input Voltage	PGA_ENx = 1, PGA_x_BOOST = 0 Scales linearly with AVDD AVDD = 1.8 V AVDD = 1.8 V AVDD = 3.3 V AVDD = 3.3 V		AVDD/3.3 0.55 1.54 1.00 2.83		V rms V rms V p-p V rms V p-p
Dynamic Range ¹	20 Hz to 20 kHz, –60 dB input				
With A-Weighted Filter (RMS)	AVDD = 1.8 V		94		dB
	AVDD = 3.3 V		102		dB
With Flat 20 Hz to 20 kHz Filter	AVDD = 1.8 V		92		dB
	AVDD = 3.3 V		98		dB

Parameter	Test Conditions/Comments	Min	Typ	Max	Unit
THD + N	20 Hz to 20 kHz, -1 dB from full-scale input AVDD = 1.8 V AVDD = 3.3 V		-88 -90		dB dB
SNR ²					
With A-Weighted Filter (RMS)	AVDD = 1.8 V AVDD = 3.3 V		94 102		dB dB
With Flat 20 Hz to 20 kHz Filter	AVDD = 1.8 V AVDD = 3.3 V		93 98		dB dB
PGA Gain Variation	Standard deviation				
With -12 dB Setting			0.05		dB
With +35.25 dB Setting			0.15		dB
PGA Boost	PGA_x_BOOST		10		dB
PGA Mute Attenuation	PGA_MUTEx		-63		dB
Interchannel Gain Mismatch			0.04		dB
Offset Error		-0.12		+0.12	mV
Gain Error			-0.05		dB
Interchannel Isolation			100		dB
PSRR	CM capacitor = 20 μ F, 100 mV p-p at 1 kHz		63		dB
MICROPHONE BIAS	MIC_ENx = 1				
Bias Voltage					
0.65 \times AVDD	AVDD = 1.8 V, MIC_GAINx = 1 AVDD = 3.3 V, MIC_GAINx = 1	1.14 2.10	1.16 2.12	1.17 2.14	V V
0.90 \times AVDD	AVDD = 1.8 V, MIC_GAINx = 0 AVDD = 3.3 V, MIC_GAINx = 0	1.61 2.95	1.63 2.97	1.65 2.99	V V
Bias Current Source				3	mA
Output Impedance			1		Ω
MICBIASx Isolation	MIC_GAINx = 0 MIC_GAINx = 1		95 99		dB dB
Noise in the Signal Bandwidth	20 Hz to 20 kHz, 4.7 μ F decoupling capacitor, 5.0 k Ω load on the MICBIASx pins				
AVDD = 1.8 V	MIC_GAINx = 0 MIC_GAINx = 1		27 16		nV/ \sqrt Hz nV/ \sqrt Hz
AVDD = 3.3 V	MIC_GAINx = 0 MIC_GAINx = 1		35 19		nV/ \sqrt Hz nV/ \sqrt Hz
DIGITAL-TO-ANALOG CONVERTERS (DACs)					
Resolution	All DACs		24		Bits
Digital Attenuation Step			0.375		dB
Digital Attenuation Range			95		dB
DAC SINGLE-ENDED OUTPUT	Single-ended operation, HPOUTLP/LOUTLP and HPOUTRP/LOUTRP pins				
Full-Scale Output Voltage	Scales linearly with AVDD AVDD = 1.8 V AVDD = 1.8 V AVDD = 3.3 V AVDD = 3.3 V		AVDD/3.4 0.53 1.5 0.97 2.74		V _{rms} V _{rms} V _{p-p} V _{rms} V _{p-p}
Mute Attenuation			-72		dB
Line Output Mode					
Dynamic Range ¹	20 Hz to 20 kHz, -60 dB input				
With A-Weighted Filter (RMS)	AVDD = 1.8 V AVDD = 3.3 V	97 102	100 104		dB dB
With Flat 20 Hz to 20 kHz Filter	AVDD = 1.8 V AVDD = 3.3 V	95 99	97 101		dB dB

Parameter	Test Conditions/Comments	Min	Typ	Max	Unit
SNR ²	20 Hz to 20 kHz				
With A-Weighted Filter (RMS)	AVDD = 1.8 V	98	100		dB
	AVDD = 3.3 V	102	104		dB
With Flat 20 Hz to 20 kHz Filter	AVDD = 1.8 V	96	98		dB
	AVDD = 3.3 V	99	102		dB
Interchannel Gain Mismatch		0	50	200	mdB
THD + N	20 Hz to 20 kHz, -1 dBFS input				dB
	AVDD = 1.8 V		-93	-89	dB
	AVDD = 3.3 V		-94	-90	dB
Gain Error		-0.13		+0.13	dB
Headphone Mode					
Dynamic Range ¹	20 Hz to 20 kHz, -60 dB input				
With A-Weighted Filter (RMS)	AVDD = 1.8 V	97	100		dB
	AVDD = 3.3 V	102	104		dB
With Flat 20 Hz to 20 kHz Filter	AVDD = 1.8 V	95	97		dB
	AVDD = 3.3 V	99	101		dB
SNR ²	20 Hz to 20 kHz				
With A-Weighted Filter (RMS)	AVDD = 1.8 V	98	100		dB
	AVDD = 3.3 V	102	104		dB
With Flat 20 Hz to 20 kHz Filter	AVDD = 1.8 V	96	98		dB
	AVDD = 3.3 V	100	102		dB
Interchannel Gain Mismatch		0	50	230	mdB
THD + N	20 Hz to 20 kHz, -1 dBFS input				
32 Ω Load	AVDD = 1.8 V, output power = 6.3 mW		-79	-67	dB
	AVDD = 3.3 V, output power = 20.5 mW		-84	-67	dB
24 Ω Load	AVDD = 1.8 V, output power = 8.4 mW		-79	-65	dB
	AVDD = 3.3 V, output power = 27 mW		-80	-64	dB
16 Ω Load	AVDD = 1.8 V, output power = 13 mW		-74	-61	dB
	AVDD = 3.3 V, output power = 30 mW		-77	-67	dB
Gain Error		-0.13		+0.13	dB
Headphone Output Power					
32 Ω Load	AVDD = 1.8 V, <0.1% THD + N		8.0		mW
	AVDD = 3.3 V, <0.1% THD + N		28.1		mW
24 Ω Load	AVDD = 1.8 V, <0.1% THD + N		11.1		mW
	AVDD = 3.3 V, <0.1% THD + N		30.5		mW
16 Ω Load	AVDD = 1.8 V, <0.1% THD + N		16.5		mW
	AVDD = 3.3 V, <0.1% THD + N		32.7		mW
Offset Error		-0.11		+0.09	mV
Interchannel Isolation	1 kHz, 0 dBFS input signal		100		dB
PSRR	CM capacitor = 22 μF, 100 mV p-p at 1 kHz		70		dB
DAC DIFFERENTIAL OUTPUT					
Full-Scale Output Voltage	Differential operation		AVDD/1.7		V _{rms}
	Scales linearly with AVDD				
	AVDD = 1.8 V		1.06		V _{rms}
	AVDD = 1.8 V		3.00		V _{p-p}
	AVDD = 3.3 V		1.94		V _{rms}
	AVDD = 3.3 V		5.49		V _{p-p}
Mute Attenuation			-72		dB
Line Output Mode					
Dynamic Range ¹	20 Hz to 20 kHz, -60 dB input				
With A-Weighted Filter (RMS)	AVDD = 1.8 V	102	105		dB
	AVDD = 3.3 V	105	107		dB
With Flat 20 Hz to 20 kHz Filter	AVDD = 1.8 V	100	102		dB
	AVDD = 3.3 V	102	105		dB

Parameter	Test Conditions/Comments	Min	Typ	Max	Unit
SNR ²	20 Hz to 20 kHz				
With A-Weighted Filter (RMS)	AVDD = 1.8 V	103	105		dB
	AVDD = 3.3 V	106	108		dB
With Flat 20 Hz to 20 kHz Filter	AVDD = 1.8 V	100	102		dB
	AVDD = 3.3 V	103	105		dB
Interchannel Gain Mismatch		0	50	200	mdB
THD + N	20 Hz to 20 kHz, -1 dBFS input				dB
	AVDD = 1.8 V		-96	-90	dB
	AVDD = 3.3 V		-96	-90	dB
Gain Error		-0.1		+0.16	dB
Headphone Mode					
Dynamic Range ¹	20 Hz to 20 kHz, -60 dB input				
With A-Weighted Filter (RMS)	AVDD = 1.8 V	102	105		dB
	AVDD = 3.3 V	105	107		dB
With Flat 20 Hz to 20 kHz Filter	AVDD = 1.8 V	100	102		dB
	AVDD = 3.3 V	102	104		dB
SNR ²	20 Hz to 20 kHz				
With A-Weighted Filter (RMS)	AVDD = 1.8 V	103	106		dB
	AVDD = 3.3 V	106	108		dB
With Flat 20 Hz to 20 kHz Filter	AVDD = 1.8 V	101	103		dB
	AVDD = 3.3 V	104	106		dB
Interchannel Gain Mismatch		0	75	370	mdB
THD + N					
32 Ω Load	-1 dBFS, AVDD = 1.8 V, output power = 26 mW		-75	-64	dB
	-1 dBFS, AVDD = 3.3 V, output power = 87 mW		-83	-75	dB
24 Ω Load	-2 dBFS, AVDD = 1.8 V, output power = 27 mW		-75	-64	dB
	-1 dBFS, AVDD = 3.3 V, output power = 115 mW		-82	-75	dB
16 Ω Load	-3 dBFS, AVDD = 1.8 V, output power = 32 mW		-75	-65	dB
	-1 dBFS, AVDD = 3.3 V, output power = 168 mW		-77	-68	dB
Gain Error	Headphone mode	-0.25		+0.25	dB
Headphone Output Power					
32 Ω Load	AVDD = 1.8 V, <0.1% THD + N		29.1		mW
	AVDD = 3.3 V, <0.1% THD + N		111.8		mW
24 Ω Load	AVDD = 1.8 V, <0.1% THD + N		31.8		mW
	AVDD = 3.3 V, <0.1% THD + N		148.3		mW
16 Ω Load	AVDD = 1.8 V, <0.1% THD + N		32.3		mW
	AVDD = 3.3 V, <0.1% THD + N		193.0		mW
Offset Error		-0.12	0	+0.08	mV
Interchannel Isolation	1 kHz, 0 dBFS input signal		100		dB
PSRR	CM capacitor = 22 μF, 100 mV p-p at 1 kHz		73		dB
ANALOG-TO-ANALOG LATENCY	f _s = 768 kHz		5		μs
	f _s = 192 kHz		38		μs
CM REFERENCE	CM pin				
Common-Mode Reference Output			AVDD/2		V
Common-Mode Source Impedance			5		kΩ
REGULATOR					
Line Regulation			1		mV/V
Load Regulation			6		mV/mA

¹ Dynamic range is the ratio of the sum of the noise and harmonic power in the band of interest with a -60 dBFS signal present vs. the full-scale power level in decibels.

² SNR is the ratio of the sum of all noise power in the band of interest with no signal present vs. the full-scale power level in decibels.

CRYSTAL AMPLIFIER SPECIFICATIONS

AVDD = IOVDD = 1.8 V, DVDD = 1.1 V, unless otherwise noted.

Table 2.

Parameter	Min	Typ	Max	Unit
CRYSTAL AMPLIFIER				
Jitter		270	500	ps rms
Frequency Range	8		27	MHz
Load Capacitance			20	pF

DIGITAL INPUT/OUTPUT SPECIFICATIONS

-40°C < T_A < +85°C, IOVDD = 3.3 V ± 10% and 1.8 V - 5% to 1.8 V + 10%, unless otherwise noted.

Table 3.

Parameter	Test Conditions/Comments	Min	Typ	Max	Unit
INPUT/OUTPUT					
Input Voltage					
High (V _{IH})	IOVDD = 3.3 V	2.0			V
	IOVDD = 1.8 V	1.1			V
Low (V _{IL})	IOVDD = 3.3 V			0.8	V
	IOVDD = 1.8 V			0.45	V
Input Leakage	IOVDD = 3.3 V, I _{IH} ¹ at V _{IH} = 2.0 V			10	μA
	I _{IL} ¹ at V _{IL} = 0.8 V			10	μA
	IOVDD = 1.8 V, I _{IH} ¹ at V _{IH} = 1.1 V			10	μA
	I _{IL} ¹ at V _{IL} = 0.45 V			10	μA
Output Voltage High (V _{OH})					
Low Drive Strength	I _{OH} ¹ = 1 mA	IOVDD - 0.6			V
High Drive Strength	I _{OH} ¹ = 3 mA	IOVDD - 0.6			V
Output Voltage Low (V _{OL})					
Low Drive Strength	I _{OL} ¹ = 1 mA			0.4	V
High Drive Strength	I _{OL} ¹ = 3 mA			0.4	V
Input Capacitance				5	pF

¹ I_{IH} is the current when the input is high; I_{IL} is the current when the input is low; I_{OH} is the current when the output is high; and I_{OL} is the current when the output is low.

POWER SUPPLY SPECIFICATIONS

AVDD = IOVDD = 1.8 V, DVDD = 1.1 V, unless otherwise noted.

Table 4.

Parameter	Test Conditions/Comments	Min	Typ	Max	Unit
SUPPLIES					
AVDD Voltage		1.71	1.8	3.63	V
DVDD Voltage		1.045	1.1	1.98	V
IOVDD Voltage		1.71	1.8	3.63	V
Analog Current (I _{AVDD})					
Normal Operation	See Table 5				
Power-Down			1.6		μA
Digital Input/Output Current (I _{IOVDD})					
Normal Operation	See Table 5				
Power-Down			1.3		μA
POWER CONSUMPTION					
All Supplies	See Table 5				
Power-Down, All Supplies			1		μW

TYPICAL POWER MANAGEMENT SETTINGS

Typical ANC settings, master clock = 12.288 MHz, PLL disabled, crystal oscillator enabled, core $f_s = \text{DAC} = \text{ADC} = 768 \text{ kHz}$. On-board regulator enabled. Two ADCs with PGA enabled and two ADCs configured for line input, no input signal. Two DACs are configured for differential headphone (HP) operation; DAC outputs are unloaded. Both MICBIAS0 and MICBIAS1 enabled at $0.9 \times \text{AVDD}$. ASRCs and pulse density modulation (PDM) modulator disabled. Core running 26 out of 32 possible instructions. Serial port set to slave. See Register 0x46 and Register 0x47 for settings.

Table 5.

Operating Voltage	Power Management Setting	Typical AVDD Current Consumption (mA)	Typical IOVDD Current Consumption (mA)	Typical ADC THD + N (dB)	Typical HP Output THD + N (dB)	Total Power Consumption (mW)
AVDD = IOVDD = 3.3 V	Normal	9.71	2.58	-91	-97	40.56
	Extreme power saving	7.55	2.57	-86	-96	33.40
	Power saving	7.99	2.57	-87	-96	34.85
	Enhanced performance	10.97	2.58	-91	-98	44.72
AVDD = IOVDD = 1.8 V	Normal	7.29	0.37	-87	-95	13.79
	Extreme power saving	5.38	0.37	-81	-89	10.35
	Power saving	5.73	0.37	-81	-90	10.98
	Enhanced Performance	8.62	0.37	-87	-95	16.18

DIGITAL FILTERS SPECIFICATIONS

Table 6.

Parameter	Test Conditions/Comments	Min	Typ	Max	Unit	
ADC INPUT TO DAC OUTPUT PATH Pass-Band Ripple	DC to 20 kHz, $f_s = 768 \text{ kHz}$	-0.03		+0.01	dB	
	DC to 20 kHz, $f_s = 192 \text{ kHz}$			± 0.02	dB	
SAMPLE RATE CONVERTER Pass Band	LRCLK < 63 kHz	0		$0.475 \times f_s$	kHz	
	63 kHz < LRCLK < 130 kHz	0		$0.4286 \times f_s$	kHz	
	LRCLK > 130 kHz	0		$0.4286 \times f_s$	kHz	
	Pass-Band Ripple	Upsampling, 96 kHz	-0.27		+0.05	dB
		Upsampling, 192 kHz	-0.06		+0.05	dB
		Downsampling, 96 kHz	0		0.07	dB
		Downsampling, 192 kHz	0		0.07	dB
Input/Output Frequency Range		8		192	kHz	
Dynamic Range			100		dB	
THD + N			-90		dB	
Start-Up Time				15	ms	
PDM MODULATOR						
	Dynamic Range (A-Weighted)		112		dB	
THD + N			-92		dB	

DIGITAL TIMING SPECIFICATIONS

-40°C < T_A < +85°C, IOVDD = 1.71 V to 3.63 V, DVDD = 1.045 V to 1.98 V.

Table 7. Digital Timing

Parameter	Limit		Unit	Description
	t _{MIN}	t _{MAX}		
MASTER CLOCK (MCLK)				
t _{MP}	37	125	ns	MCLKIN period; 8 MHz to 27 MHz input clock using PLL
t _{MCLK}	77	82	ns	Internal MCLK period; direct MCLK and PLL output divided by 2
SERIAL PORT				
t _{BL}	40		ns	BCLK low pulse width (master and slave modes)
t _{BH}	40		ns	BCLK high pulse width (master and slave modes)
t _{LS}	10		ns	LRCLK setup; time to BCLK rising (slave mode)
t _{LH}	10		ns	LRCLK hold; time from BCLK rising (slave mode)
t _{SS}	5		ns	DAC_SD _{DATA} setup; time to BCLK rising (master and slave modes)
t _{SH}	5		ns	DAC_SD _{DATA} hold; time from BCLK rising (master and slave modes)
t _{TS}		10	ns	BCLK falling to LRCLK timing skew (master mode)
t _{SOD}	0	34	ns	ADC_SD _{DATAx} delay; time from BCLK falling (master and slave modes)
t _{SOTD}		30	ns	BCLK falling to ADC_SD _{DATAx} driven in time-division multiplexing (TDM) tristate mode
t _{SOTX}		30	ns	BCLK falling to ADC_SD _{DATAx} tristate in TDM tristate mode
SERIAL PERIPHERAL INTERFACE (SPI) PORT				
f _{SCLK}		6.25	MHz	SCLK frequency
t _{CCPL}	80		ns	SCLK pulse width low
t _{CCPH}	80		ns	SCLK pulse width high
t _{CLS}	5		ns	\overline{SS} setup; time to SCLK rising
t _{CLH}	100		ns	\overline{SS} hold; time from SCLK rising
t _{CLPH}	80		ns	\overline{SS} pulse width high
t _{CDS}	10		ns	MOSI setup; time to SCLK rising
t _{CDH}	10		ns	MOSI hold; time from SCLK rising
t _{COD}		101	ns	MISO delay; time from SCLK falling
I²C PORT				
f _{SCL}		400	kHz	SCL frequency
t _{SCLH}	0.6		μs	SCL high
t _{SCLL}	1.3		μs	SCL low
t _{SCS}	0.6		μs	SCL rise setup time (to SDA falling), relevant for repeated start condition
t _{SCR}		250	ns	SCL and SDA rise time, C _{LOAD} = 400 pF
t _{SCH}	0.6		μs	SCL fall hold time (from SDA falling), relevant for start condition
t _{DS}	100		ns	SDA setup time (to SCL rising)
t _{SCF}		250	ns	SCL and SDA fall time; C _{LOAD} = 400 pF
t _{BFT}	0.6		μs	SCL rise setup time (to SDA rising), relevant for stop condition
I²C EEPROM SELF BOOT				
t _{SCHE}	26 × t _{MP} - 70		ns	SCL fall hold time (from SDA falling), relevant for start condition; t _{MP} is the input clock on the MCLKIN pin
t _{SCSE}	38 × t _{MP} - 70		ns	SCL rise setup time (to SDA falling), relevant for repeated start condition
t _{BFTE}	70 × t _{MP} - 70		ns	SCL rise setup time (to SDA rising), relevant for stop condition
t _{DSE}	6 × t _{MP} - 70		ns	Delay from SCL falling to SDA changing
t _{BHTE}	32 × t _{MP}		ns	SDA rising in self boot stop condition to SDA falling edge for external master start condition

Parameter	Limit		Unit	Description
	t _{MIN}	t _{MAX}		
MULTIPURPOSE AND POWER-DOWN PINS				
t _{GIL}		1.5 × 1/f _s	μs	MPx input latency; time until high or low value is read by core
t _{RLPW}	20		ns	\overline{PD} low pulse width
DIGITAL MICROPHONE				
t _{CF}		20	ns	Digital microphone clock fall time
t _{CR}		20	ns	Digital microphone clock rise time
t _{DS}	40			Digital microphone valid data start time
t _{DE}		0	ns	Digital microphone valid data end time
PDM OUTPUT				
t _{DCF}		20	ns	PDM clock fall time
t _{DCR}		20	ns	PDM clock rise time
t _{DDV}	0	30	ns	PDM delay time for valid data

Digital Timing Diagrams

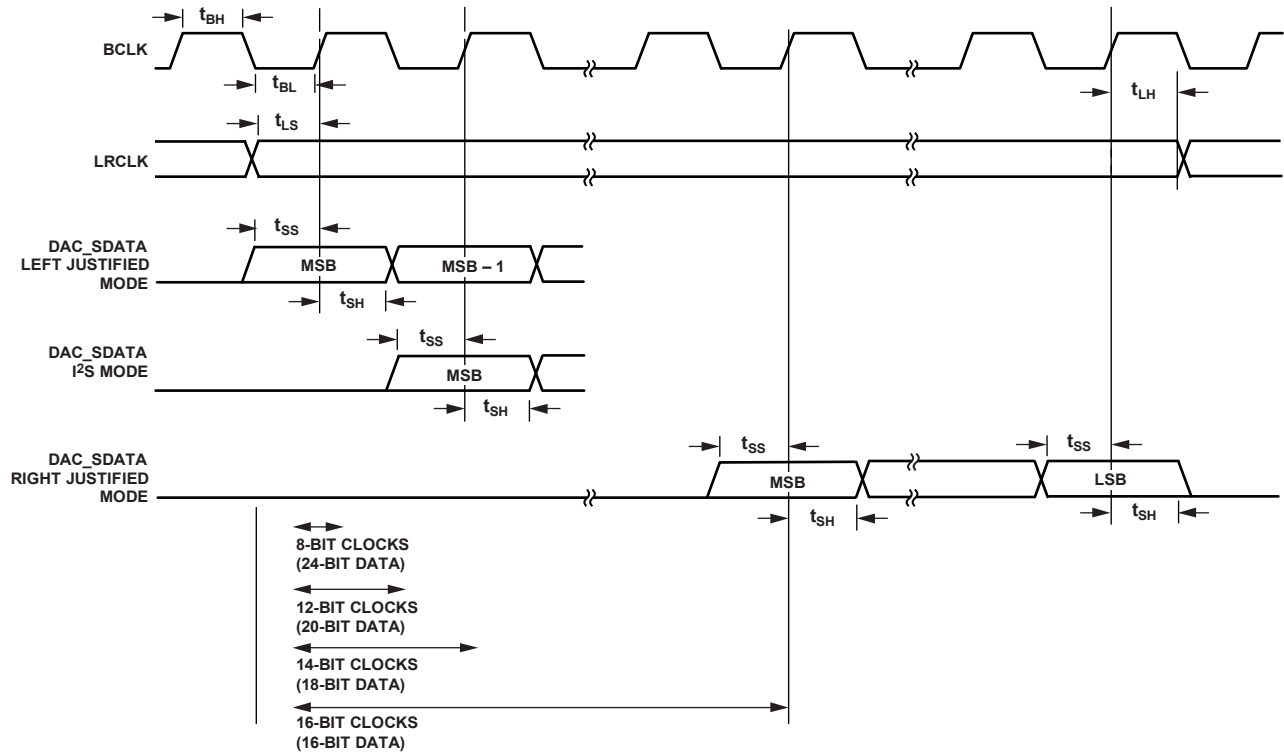

Figure 2. Serial Input Port Timing

147586-002

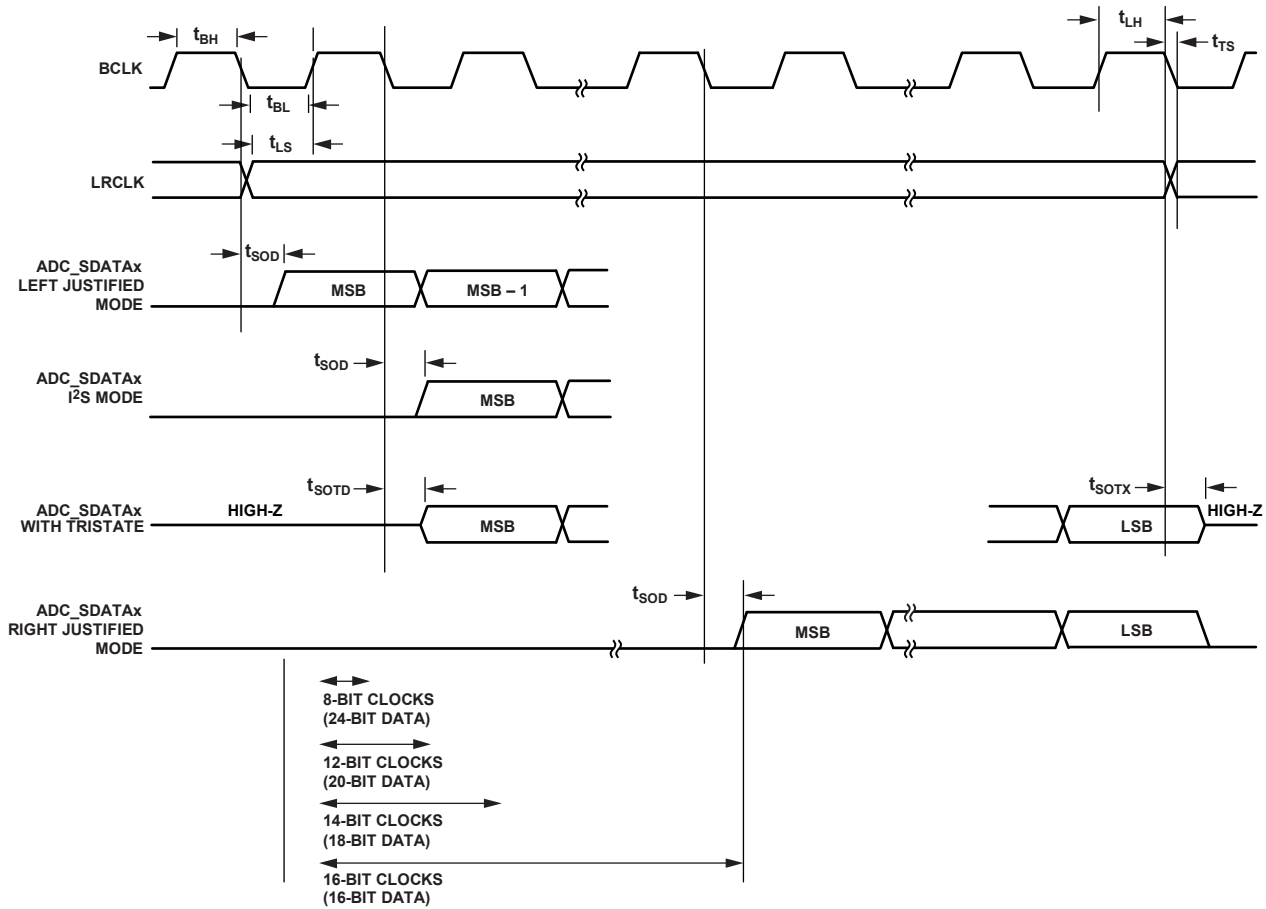

Figure 3. Serial Output Port Timing

14796-003

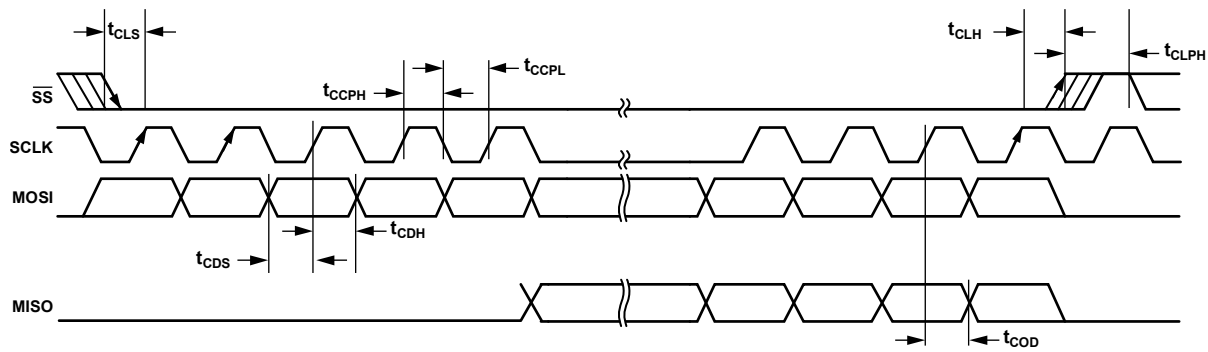

Figure 4. SPI Port Timing

14796-004

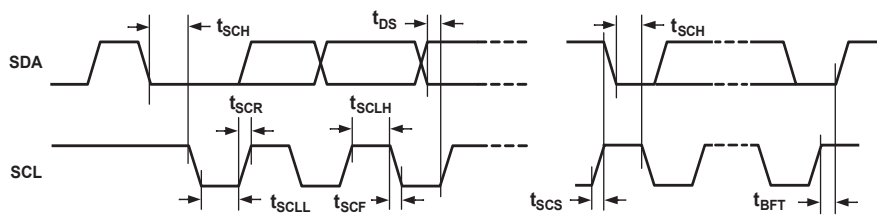

Figure 5. I²C Port Timing

14796-005

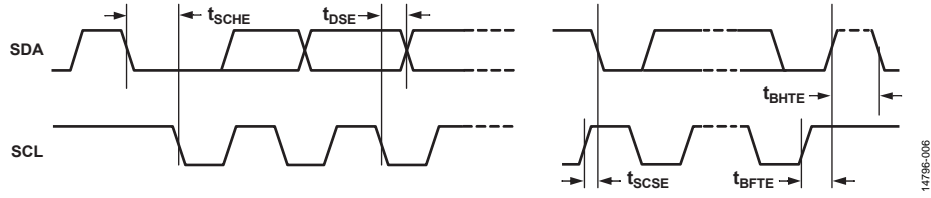

Figure 6. I²C EEPROM Self Boot Timing

14796-006

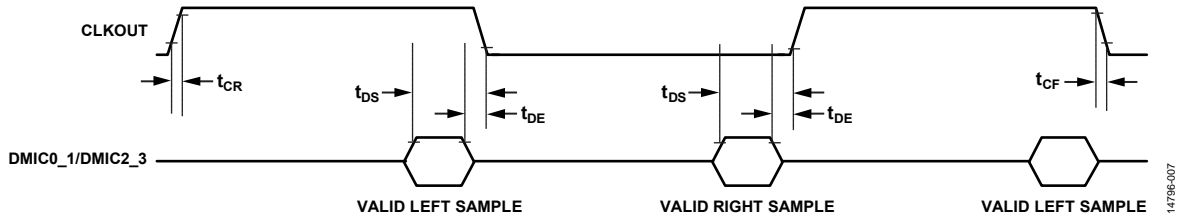

Figure 7. Digital Microphone Timing

14796-007

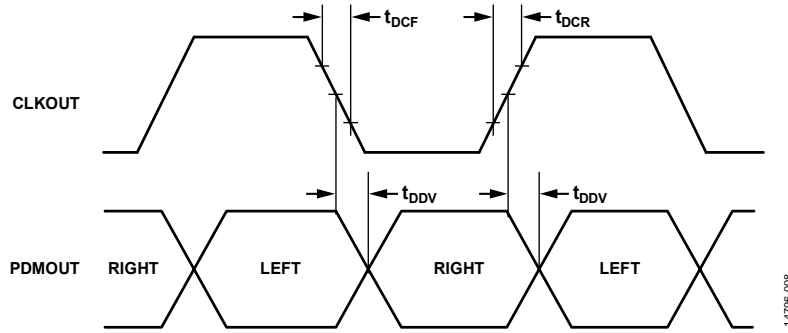

Figure 8. PDM Output Timing

14796-008

ABSOLUTE MAXIMUM RATINGS

Table 8.

Parameter	Rating
Power Supplies (AVDD, IOVDD)	-0.3 V to +3.63 V
Digital Supply (DVDD)	-0.3 V to +1.98 V
Input Current (Except Supply Pins)	±20 mA
Analog Input Voltage (Signal Pins)	-0.3 V to AVDD + 0.3 V
Digital Input Voltage (Signal Pins)	-0.3 to IOVDD + 0.3 V
Operating Temperature Range (Case)	-40°C to +85°C
Storage Temperature Range	-65°C to +150°C

Stresses at or above those listed under Absolute Maximum Ratings may cause permanent damage to the product. This is a stress rating only; functional operation of the product at these or any other conditions above those indicated in the operational section of this specification is not implied. Operation beyond the maximum operating conditions for extended periods may affect product reliability.

THERMAL RESISTANCE

Thermal performance is directly linked to printed circuit board (PCB) design and operating environment. Careful attention to PCB thermal design is required. θ_{JA} is the natural convection junction-to-ambient thermal resistance measured in a one cubic foot sealed enclosure

For more information, see the [AN-617 Application Note](#), *Wafer Level Chip Scale Package*.

Table 9. Thermal Resistance

Package Type	θ_{JA}	Unit
CB-36-4 ¹	36	°C/W

¹ Thermal impedance simulated values are based on a 4-layer PCB with two signal layers and two power planes using natural convection cooling. See JEDEC JESD51-9.

ESD CAUTION



ESD (electrostatic discharge) sensitive device. Charged devices and circuit boards can discharge without detection. Although this product features patented or proprietary protection circuitry, damage may occur on devices subjected to high energy ESD. Therefore, proper ESD precautions should be taken to avoid performance degradation or loss of functionality.

PIN CONFIGURATION AND FUNCTION DESCRIPTIONS

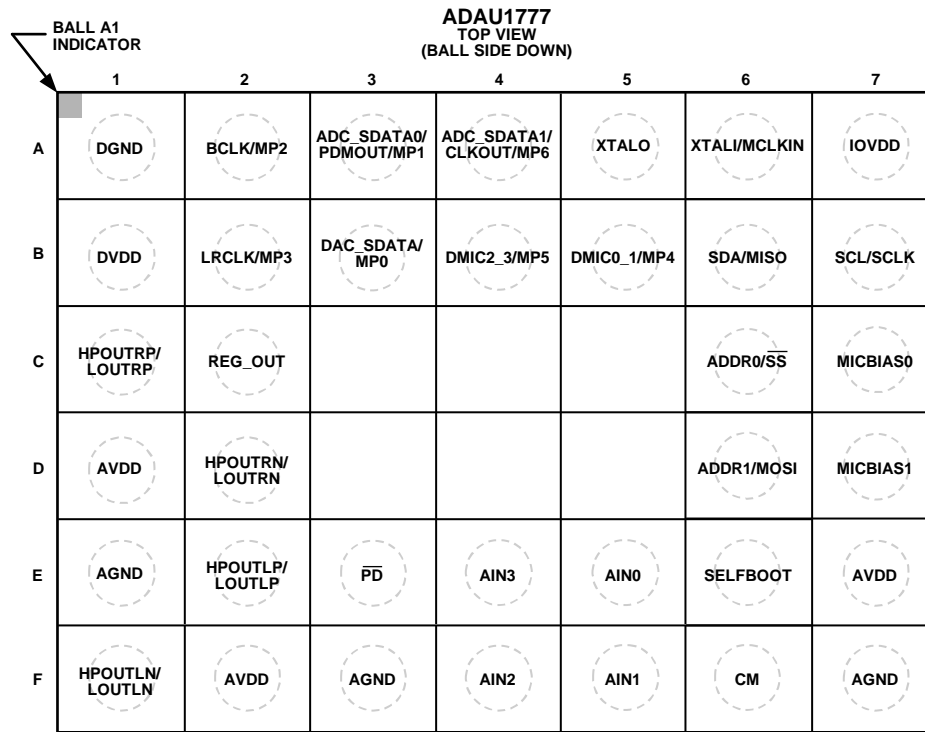

Figure 9. Pin Configuration

Table 10. Pin Function Descriptions

Pin No.	Mnemonic	Type ¹	Description
A1	DGND	PWR	Digital Ground. Tie the AGND and DGND pins directly together in a common ground plane.
A2	BCLK/MP2	D_IO	Serial Data Port Bit Clock (BCLK). Multipurpose Pin (MP2).
A3	ADC_SDATA0/PDMOUT/MP1	D_IO	ADC Serial Data Output 0 (ADC_SDATA0). Stereo PDM Output to Drive a High Efficiency Class-D Amplifier (PDMOUT). Multipurpose Pin (MP1).
A4	ADC_SDATA1/CLKOUT/MP6	D_IO	Serial Data Output 1 (ADC_SDATA1). Master Clock Output/Clock for the Digital Microphone Input and PDM Output (CLKOUT). Multipurpose Pin (MP6).
A5	XTALO	A_OUT	Crystal Clock Output. This pin is the output of the crystal amplifier; do not use this pin to provide a clock to other ICs in the system. If a master clock output is needed, use CLKOUT (Pin A4).
A6	XTALI/MCLKIN	D_IN	Crystal Clock Input (XTALI). Master Clock Input (MCLKIN).
A7	IOVDD	PWR	Supply for Digital Input and Output Pins. The digital output pins are supplied from IOVDD; thus, the IOVDD voltage level is the highest input voltage that can be present on the digital input pins. The current draw of this pin is variable because it is dependent on the loads of the digital outputs. Decouple IOVDD to DGND with a 0.1 μ F capacitor.
B1	DVDD	PWR	Digital Core Supply. The digital supply can be generated from an on-board regulator or supplied directly from an external supply. In each case, decouple DVDD to DGND with a 0.1 μ F capacitor.
B2	LRCLK/MP3	D_IO	Serial Data Port Frame Clock (LRCLK). Multipurpose Pin (MP3).
B3	DAC_SDATA/MP0	D_IO	DAC Serial Input Data (DAC_SDATA). Multipurpose Pin (MP0).
B4	DMIC2_3/MP5	D_IN	Digital Microphone Stereo Input 2 and Digital Microphone Stereo Input 3 (DMIC2_3). Multipurpose Pin (MP5).

Pin No.	Mnemonic	Type ¹	Description
B5	DMIC0_1/MP4	D_IN	Digital Microphone Stereo Input 0 and Digital Microphone Stereo Input 1 (DMIC0_1). Multipurpose Pin (MP4).
B6	SDA/MISO	D_IO	I ² C Data (SDA). This pin is a bidirectional open-collector. The line connected to this pin must have a 2.0 k Ω pull-up resistor. SPI Data Output (MISO). This SPI data output reads back registers and memory locations. It is tristated when an SPI read is not active.
B7	SCL/SCLK	D_IN	I ² C Clock (SCL). This pin is always an open-collector input when the device is in I ² C control mode. When the device is in self boot mode, this pin is an open-collector output (I ² C master). The line connected to this pin must have a 2.0 k Ω pull-up resistor. SPI Clock (SCLK). This pin either can run continuously or be gated off between SPI transactions.
C1	HPOUTRP/LOUTRP	A_OUT	Right Headphone Output Noninverted (HPOUTRP). Line Output Noninverted, Single-Ended Line Output (LOUTRP).
C2	REG_OUT	A_OUT	Regulator Output Voltage. Connect this pin to DVDD if the internal voltage regulator is being used to generate the DVDD voltage.
C6	ADDR0/ \overline{SS}	D_IN	I ² C Address 0 (ADDR0). SPI Latch Signal (\overline{SS}). This pin must go low at the beginning of an SPI transaction and high at the end of a transaction. Each SPI transaction can take a different number of SCLK cycles to complete, depending on the address and read/write bit that are sent at the beginning of the SPI transaction.
C7	MICBIAS0	A_OUT	Bias Voltage for Electret Microphone. Decouple this pin with a 1 μ F capacitor.
D1	AVDD	PWR	Headphone Amplifier Power, 1.8 V to 3.3 V Analog Supply. Decouple this pin to AGND with a 0.1 μ F capacitor. The PCB trace to this pin must have the capacity to supply the higher current necessary for driving the headphone outputs.
D2	HPOUTRN/LOUTRN	A_OUT	Right Headphone Output Inverted (HPOUTRN). Line Output Inverted (LOUTRN).
D6	ADDR1/MOSI	D_IN	I ² C Address 1 (ADDR1). SPI Data Input (MOSI).
D7	MICBIAS1	A_OUT	Bias Voltage for Electret Microphone. Decouple this pin with a 1 μ F capacitor.
E1	AGND	PWR	Headphone Amplifier Ground.
E2	HPOUTLP/LOUTLP	A_OUT	Left Headphone Output Noninverted (HPOUTLP). Line Output Noninverted, Single-Ended Line Output (LOUTLP).
E3	\overline{PD}	D_IN	Active Low Power-Down. All digital and analog circuits are powered down. An internal pull-down resistor is on this pin; therefore, the ADAU1777 is held in power-down mode if its input signal is floating while power is applied to the supply pins.
E4	AIN3	A_IN	ADC3 Input.
E5	AIN0	A_IN	ADC0 Input.
E6	SELFBOT	D_IN	Self Boot Enable. Pull this pin up to IOVDD at power-up to enable the self boot mode.
E7	AVDD	PWR	1.8 V to 3.3 V Analog Supply. Decouple this pin to AGND with a 0.1 μ F capacitor.
F1	HPOUTLN/LOUTLN	A_OUT	Left Headphone Output Inverted (HPOUTLN). Line Output Inverted (LOUTLN).
F2	AVDD	PWR	1.8 V to 3.3 V Analog Supply. Decouple this pin to AGND with a 0.1 μ F capacitor.
F3	AGND	PWR	Analog Ground.
F4	AIN2	A_IN	ADC2 Input.
F5	AIN1	A_IN	ADC1 Input.
F6	CM	A_OUT	AVDD/2 V Common-Mode Reference. Connect a 10 μ F to 47 μ F decoupling capacitor between this pin and ground to reduce crosstalk between the ADCs and DACs. The material of the capacitors is not critical. This pin can bias external analog circuits, as long as they are not drawing current from CM (for example, the noninverting input of an op amp).
F7	AGND	PWR	Analog Ground. The AGND and DGND pins can be tied directly together in a common ground plane. Decouple AGND to AVDD with a 0.1 μ F capacitor.

¹ PWR is power; D_IO is digital input/output; A_OUT is analog output; D_IN is digital input; and A_IN is analog input.

TYPICAL PERFORMANCE CHARACTERISTICS

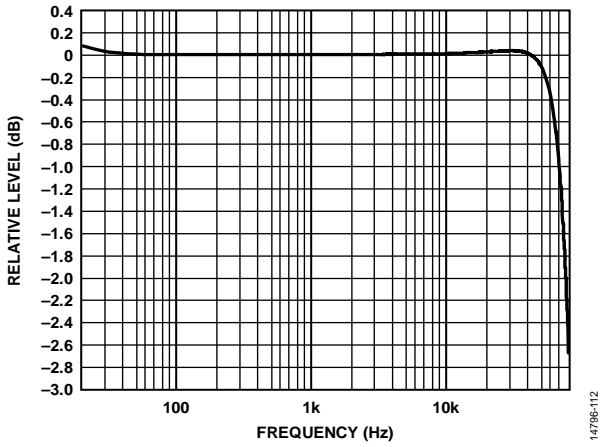

Figure 10. Relative Level vs. Frequency, $f_s = 96$ kHz, Signal Path = AIN0 to DSP (Without Processing) to LOU TLx

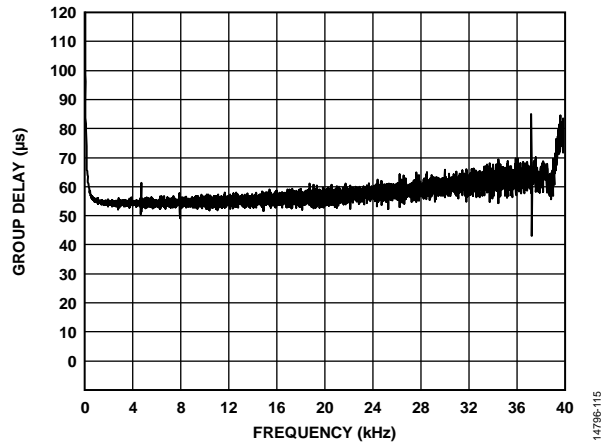

Figure 13. Group Delay vs. Frequency, $f_s = 96$ kHz, Signal Path = AIN0 to DSP (Without Processing) to LOU TLx

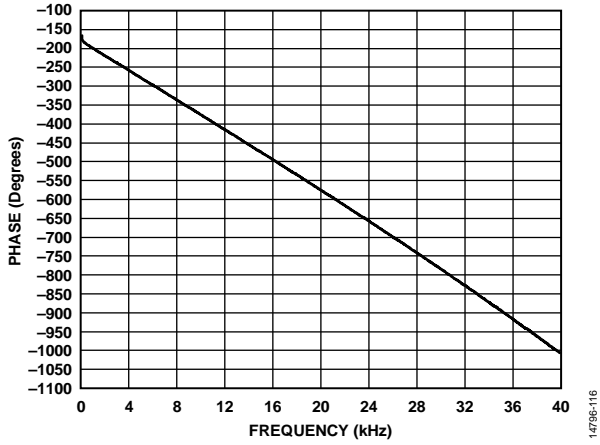

Figure 11. Phase vs. Frequency, 40 kHz Bandwidth, $f_s = 96$ kHz, Signal Path = AIN0 to DSP (Without Processing) to LOU TLx

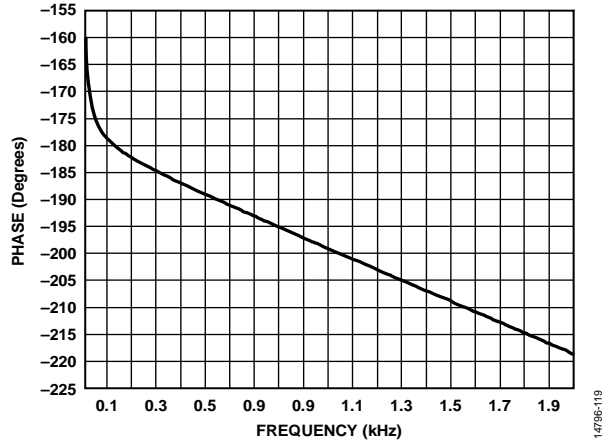

Figure 14. Phase vs. Frequency, 2 kHz Bandwidth, $f_s = 96$ kHz, Signal Path = AIN0 to DSP (Without Processing) to LOU TLx

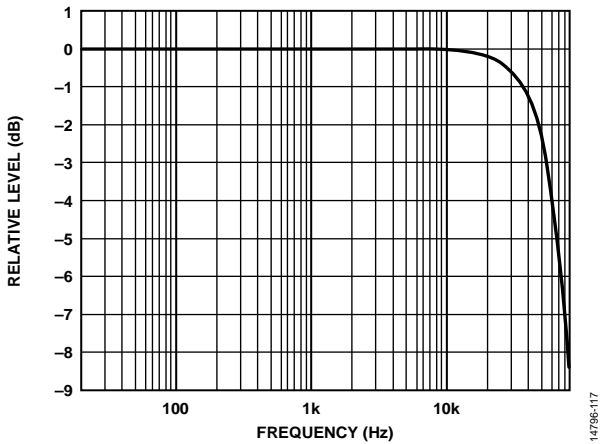

Figure 12. Relative Level vs. Frequency, $f_s = 192$ kHz, Signal Path = AIN0 to DSP (Without Processing) to LOU TLx

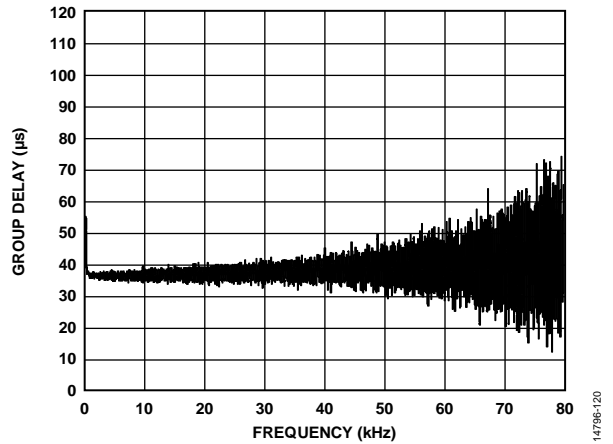
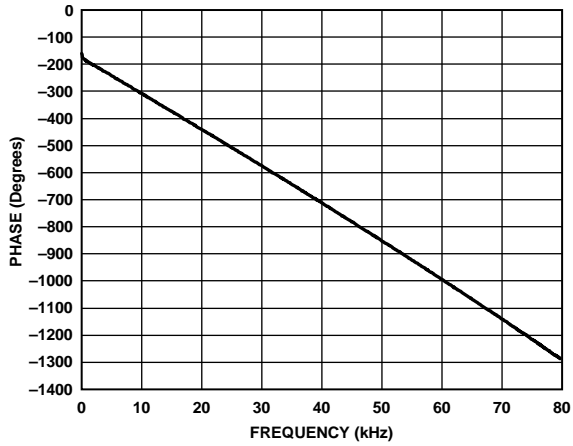
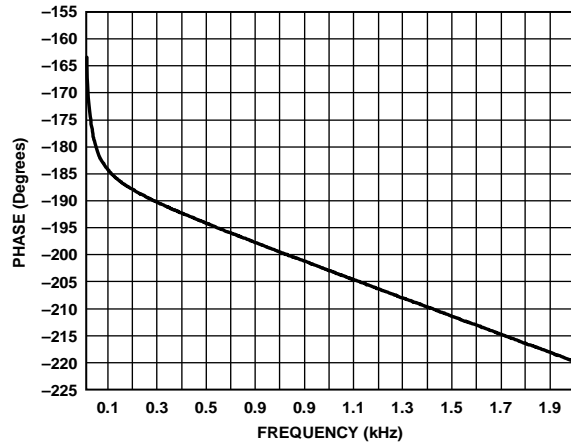

Figure 15. Group Delay vs. Frequency, $f_s = 192$ kHz, Signal Path = AIN0 to DSP (Without Processing) to LOU TLx



14796-118

Figure 16. Phase vs. Frequency, 80 kHz Bandwidth, $f_s = 192$ kHz, Signal Path = AIN0 to DSP (Without Processing) to LOU TLx



14796-121

Figure 19. Phase vs. Frequency, 2 kHz Bandwidth, $f_s = 192$ kHz, Signal Path = AIN0 to DSP (Without Processing) to LOU TLx

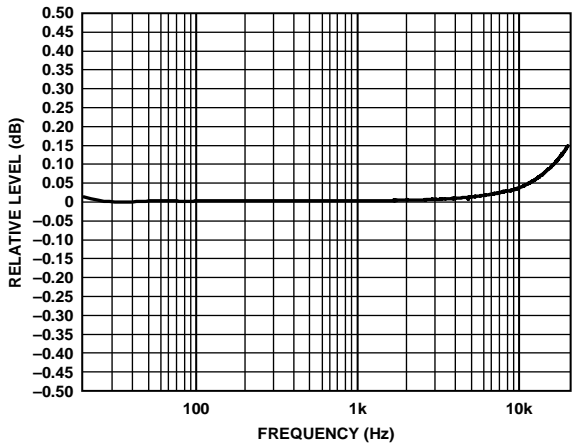

14796-222

Figure 17. Relative Level vs. Frequency, $f_s = 768$ kHz, Signal Path = AIN0 to DSP (Without Processing) to LOU TLx

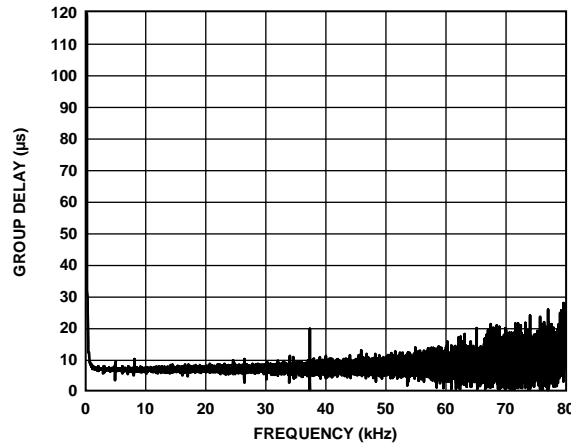

14796-225

Figure 20. Group Delay vs. Frequency, $f_s = 768$ kHz, Signal Path = AIN0 to DSP (Without Processing) to LOU TLx

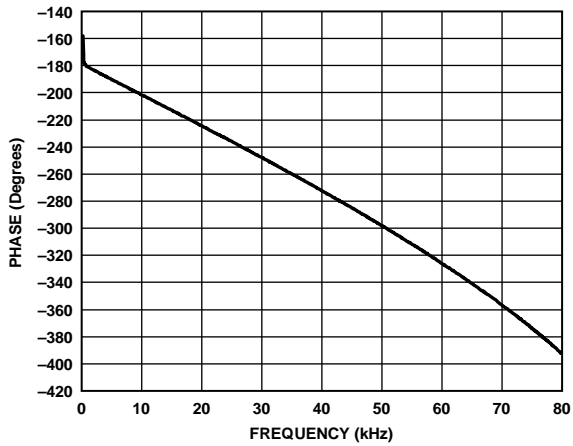

14796-223

Figure 18. Phase vs. Frequency, 80 kHz Bandwidth, $f_s = 768$ kHz, Signal Path = AIN0 to DSP (Without Processing) to LOU TLx

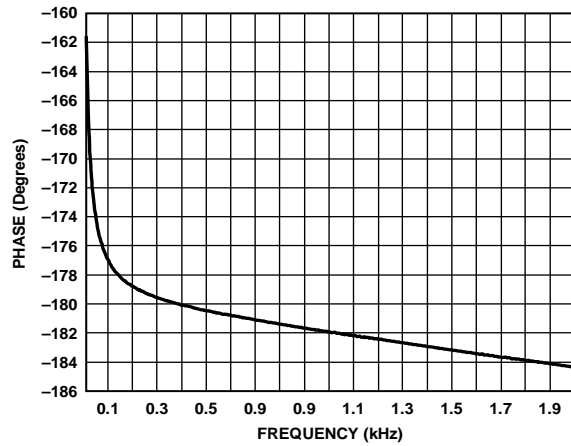

14796-226

Figure 21. Phase vs. Frequency, 2 kHz Bandwidth, $f_s = 768$ kHz, Signal Path = AIN0 to DSP (Without Processing) to LOU TLx

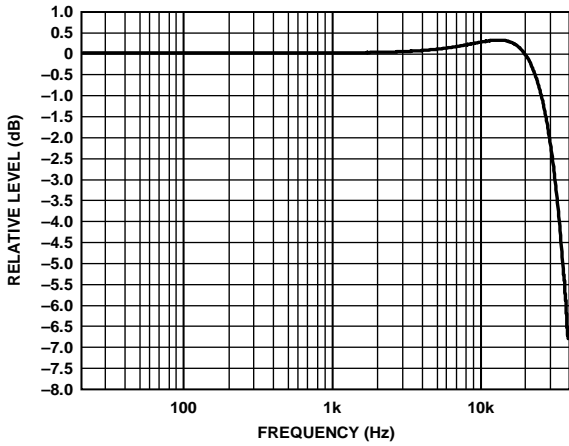

14796-124

Figure 22. Relative Level vs. Frequency, $f_s = 96$ kHz, Signal Path = AIN0 to ASRC to ADC_SDATA0

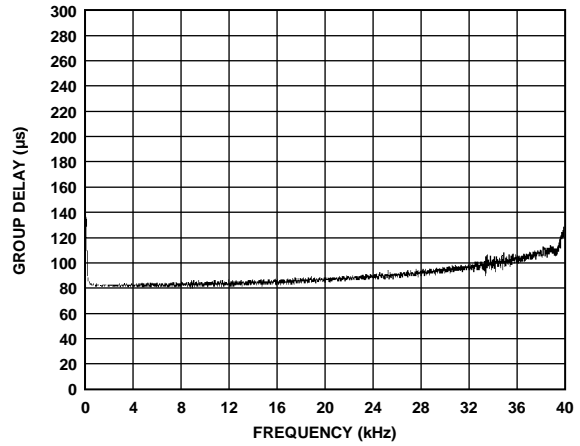

14796-127

Figure 25. Group Delay vs. Frequency, $f_s = 96$ kHz, Signal Path = AIN0 to ASRC to ADC_SDATA0

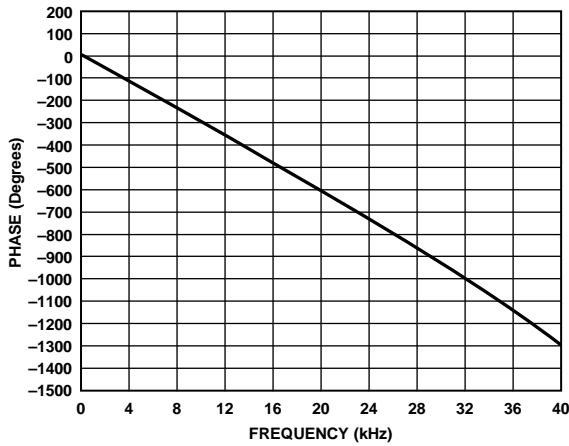

14796-128

Figure 23. Phase vs. Frequency, 40 kHz Bandwidth, $f_s = 96$ kHz, Signal Path = AIN0 to ASRC to ADC_SDATA0

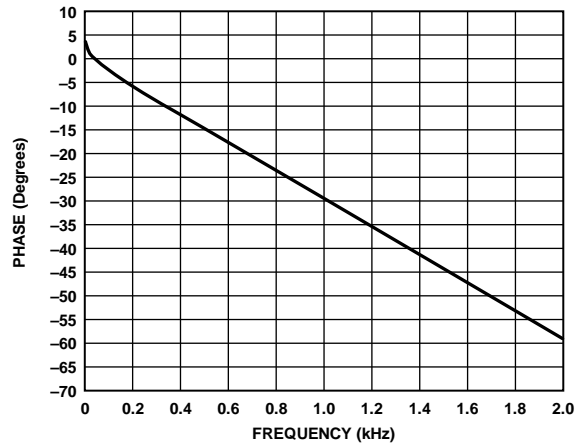

14796-131

Figure 26. Phase vs. Frequency, 2 kHz Bandwidth, $f_s = 96$ kHz, Signal Path = AIN0 to ASRC to ADC_SDATA0

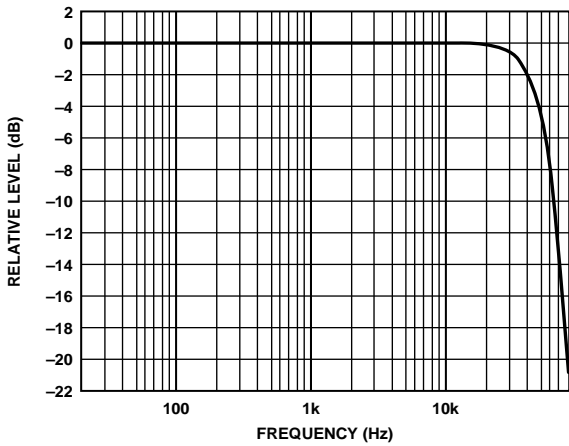

14796-128

Figure 24. Relative Level vs. Frequency, $f_s = 192$ kHz, Signal Path = AIN0 to ASRC to ADC_SDATA0

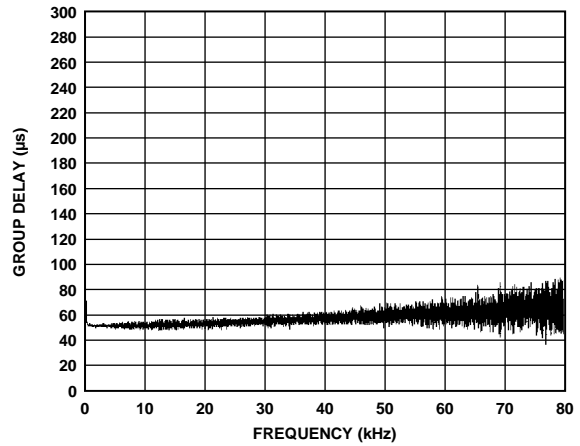

14796-132

Figure 27. Group Delay vs. Frequency, $f_s = 192$ kHz, Signal Path = AIN0 to ASRC to ADC_SDATA0

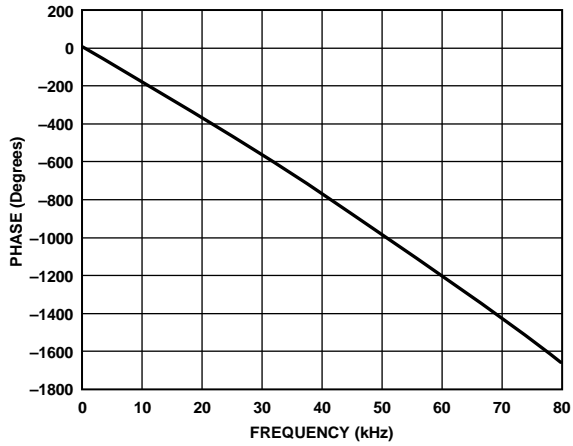

14796-130

Figure 28. Phase vs. Frequency, 80 kHz Bandwidth, $f_s = 192$ kHz, Signal Path = AIN0 to ASRC to ADC_SDAT00

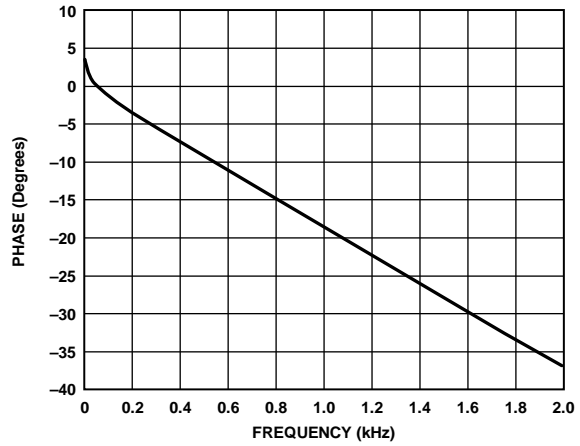

14796-133

Figure 31. Phase vs. Frequency, 2 kHz Bandwidth, $f_s = 192$ kHz, Signal Path = AIN0 to ASRC to ADC_SDAT00

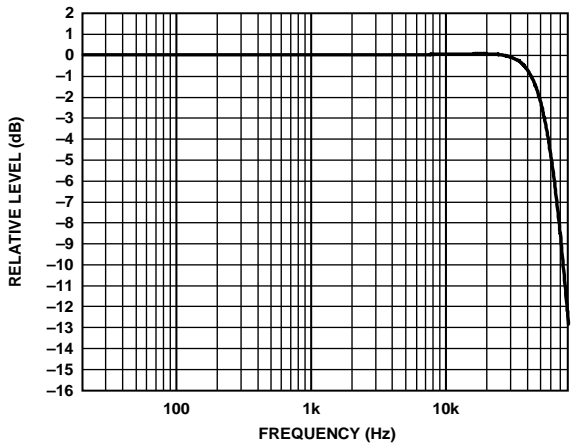

14796-227

Figure 29. Relative Level vs. Frequency, $f_s = 786$ kHz, Signal Path = AIN0 to ASRC to ADC_SDAT00

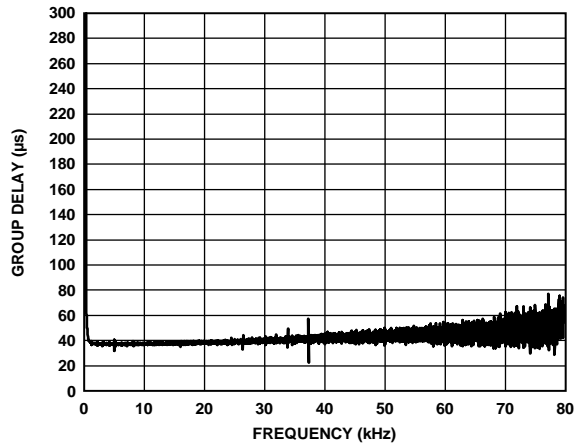

14796-229

Figure 32. Group Delay vs. Frequency, $f_s = 786$ kHz, Signal Path = AIN0 to ASRC to ADC_SDAT00

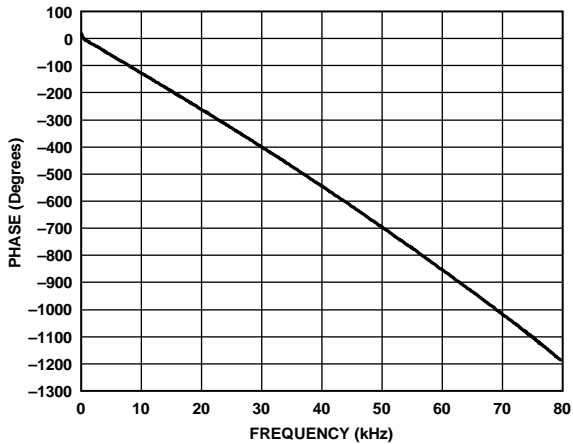

14796-228

Figure 30. Phase vs. Frequency, 80 kHz Bandwidth, $f_s = 786$ kHz, Signal Path = AIN0 to ASRC to ADC_SDAT00

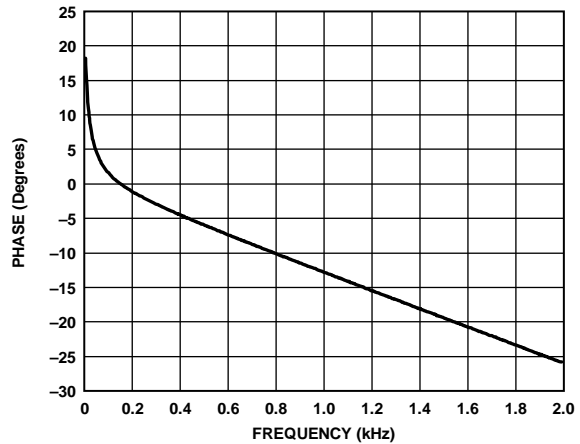

14796-230

Figure 33. Phase vs. Frequency, 2 kHz Bandwidth, $f_s = 786$ kHz, Signal Path = AIN0 to ASRC to ADC_SDAT00

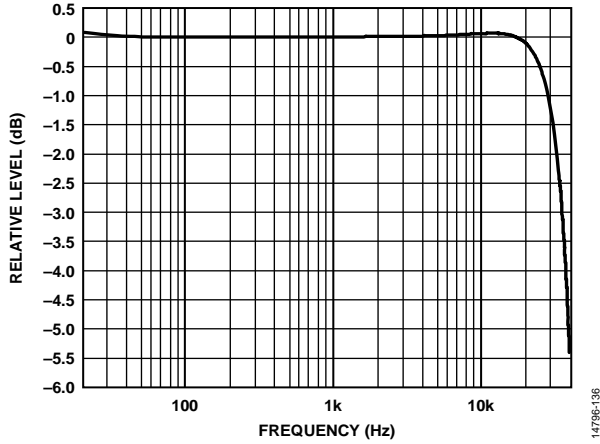

Figure 34. Relative Level vs. Frequency, $f_s = 96$ kHz, Signal Path = DAC_SDATA to ASRC to LOU TLx

14796-136

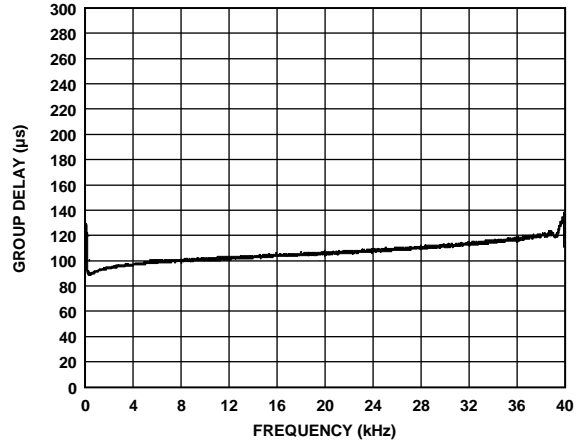

Figure 37. Group Delay vs. Frequency, $f_s = 96$ kHz, Signal Path = DAC_SDATA to ASRC to LOU TLx

14796-139

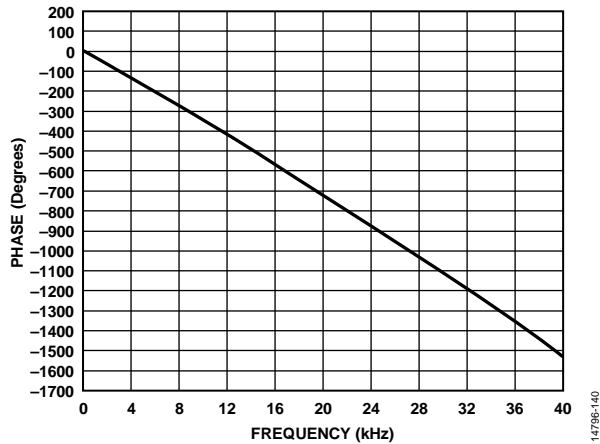

Figure 35. Phase vs. Frequency, 40 kHz Bandwidth, $f_s = 96$ kHz, Signal Path = DAC_SDATA to ASRC to LOU TLx

14796-140

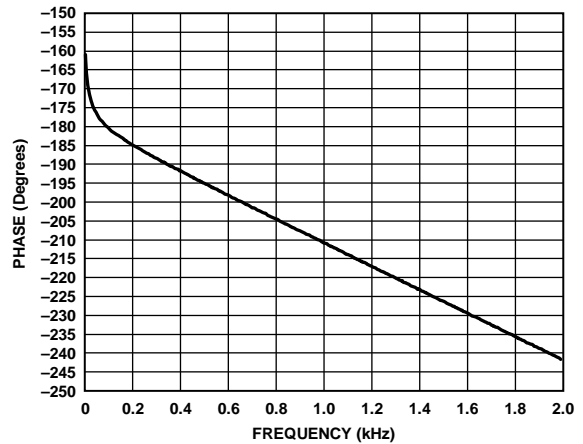

Figure 38. Phase vs. Frequency, 2 kHz Bandwidth, $f_s = 96$ kHz, Signal Path = DAC_SDATA to ASRC to LOU TLx

14796-143

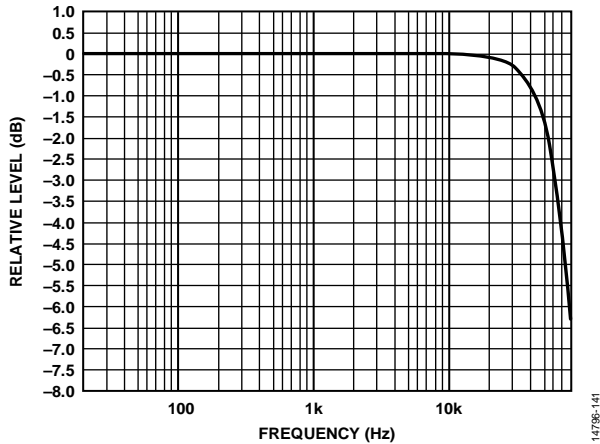

Figure 36. Relative Level vs. Frequency, $f_s = 192$ kHz, Signal Path = DAC_SDATA to ASRC to LOU TLx

14796-141

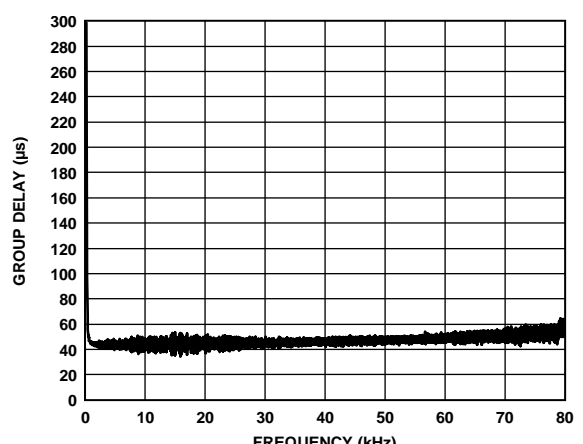
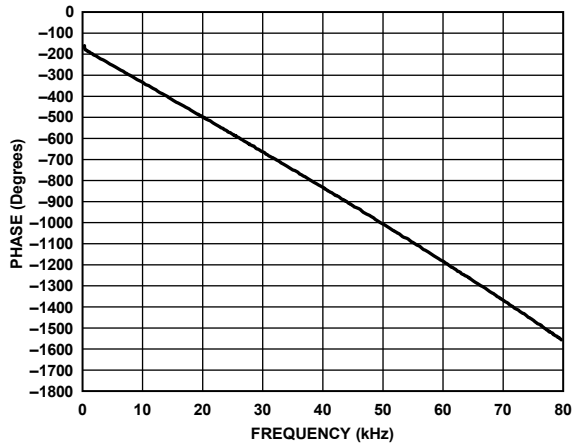

Figure 39. Group Delay vs. Frequency, $f_s = 192$ kHz, Signal Path = DAC_SDATA to ASRC to LOU TLx

14796-144



14796-142

Figure 40. Phase vs. Frequency, 80 kHz Bandwidth, $f_s = 192$ kHz, Signal Path = DAC_SDATA to ASRC to LOU TLx

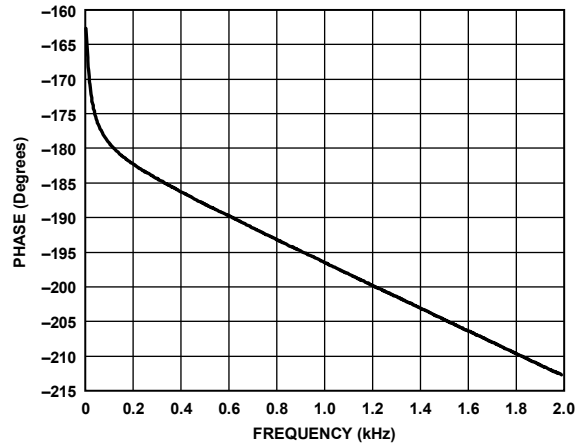

14796-145

Figure 43. Phase vs. Frequency, 2 kHz Bandwidth, $f_s = 192$ kHz, Signal Path = DAC_SDATA to ASRC to LOU TLx

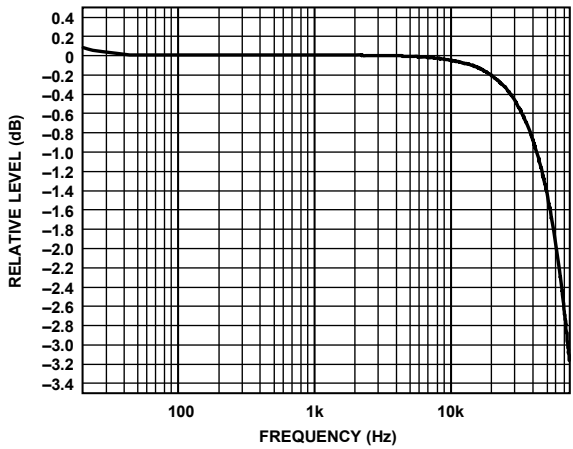

14796-231

Figure 41. Relative Level vs. Frequency, $f_s = 786$ kHz, Signal Path = DAC_SDATA to ASRC to LOU TLx

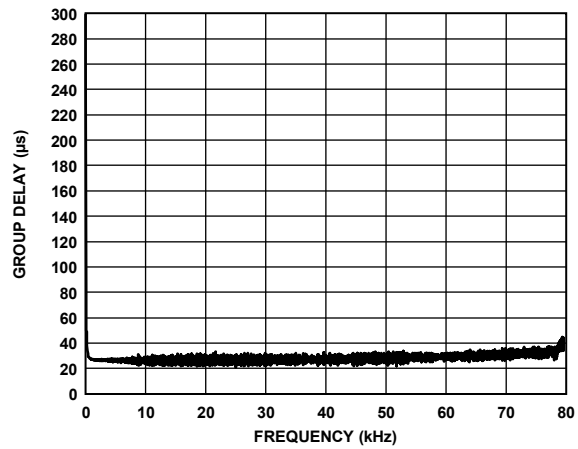

14796-233

Figure 44. Group Delay vs. Frequency, $f_s = 786$ kHz, Signal Path = DAC_SDATA to ASRC to LOU TLx

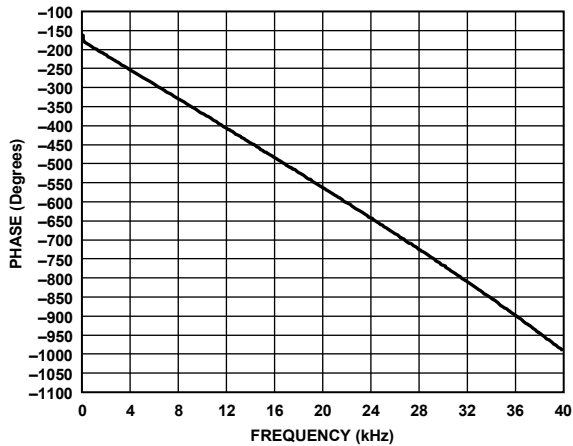

14796-232

Figure 42. Phase vs. Frequency, 20 kHz Bandwidth, $f_s = 786$ kHz, Signal Path = DAC_SDATA to ASRC to LOU TLx

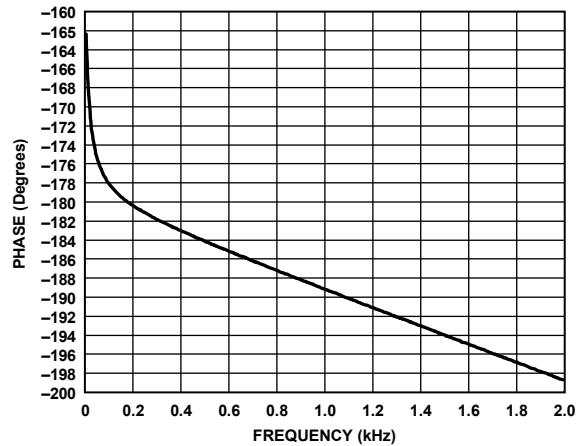

14796-234

Figure 45. Phase vs. Frequency, 2 kHz Bandwidth $f_s = 786$ kHz, Signal Path = DAC_SDATA to ASRC to LOU TLx

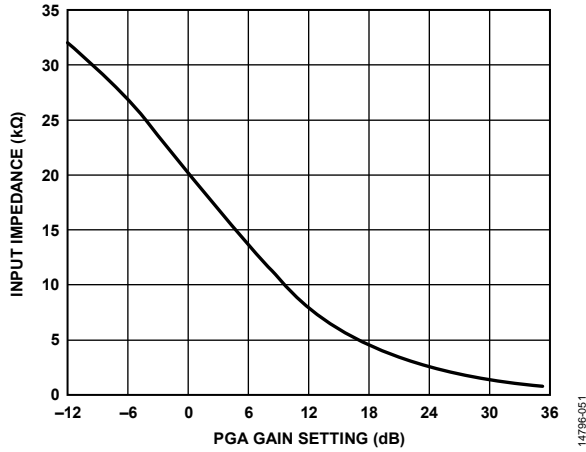

Figure 46. Input Impedance vs. PGA Gain Setting
(See the Input Impedance Section)

14796-051

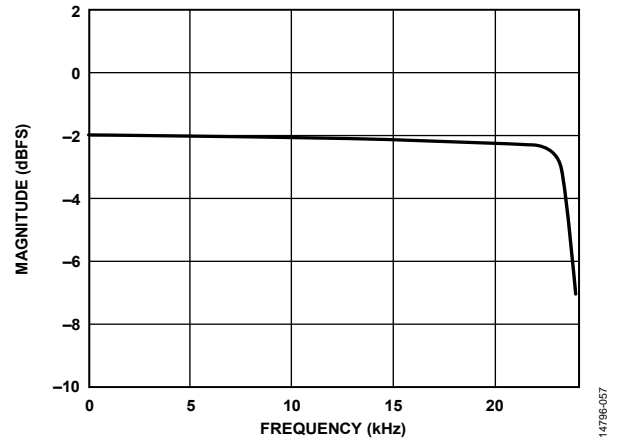

Figure 49. Interpolation Pass Band Response, $f_s = 768$ kHz

14796-057

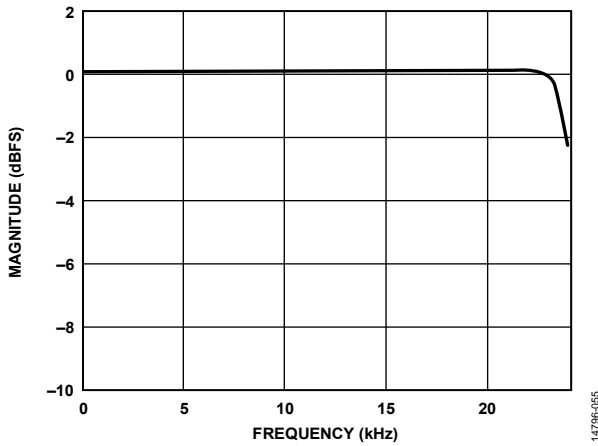

Figure 47. Decimation Pass Band Response, $f_s = 768$ kHz

14796-055

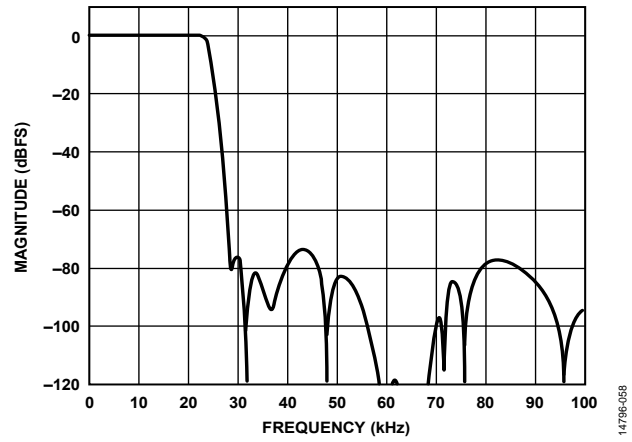

Figure 50. Total Interpolation Response, $f_s = 768$ kHz

14796-058

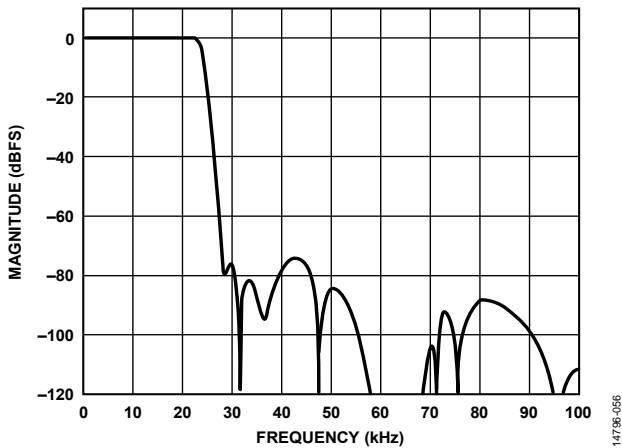

Figure 48. Total Decimation Response, $f_s = 768$ kHz

14796-056

THEORY OF OPERATION

The ADAU1777 is a low power audio codec with a streamlined audio processing core, making it ideal for noise canceling applications that require high quality audio, low power, small size, and low latency. The operating voltage range is 1.71 V to 3.63 V, with an on-board regulator optionally generating the internal digital supply voltage. By enabling low latency settings, the ADAU1777 can reach latencies as low as 5 μ s.

The ADCs and DACs are high quality, 24-bit, Σ - Δ converters that operate at a selectable 768 kHz, 192 kHz, or 96 kHz sampling rate. The ADCs have an optional high-pass filter with a cutoff frequency of 1 Hz, 4 Hz, or 8 Hz. The ADCs and DACs also include fine step digital volume controls.

The stereo DAC output can differentially drive a headphone earpiece speaker with 16 Ω or higher impedance. One side of the differential output can be powered down if single-ended operation is required. There is also the option to change to line output mode when the output has a low load.

The input signal path is flexible and can accept single-ended analog microphone inputs, serial audio inputs, and digital microphone inputs. Two microphone bias pins provide seamless interfacing to electret microphones. Each analog input has an independent PGA that can be used for volume adjustment. The serial data port is compatible with I²S, left justified, right justified, and TDM modes, with tristating for interfacing to digital audio data streams.

The core has a reduced instruction set that is optimized for active noise cancellation. The program and parameter RAMs can be loaded with custom audio processing signal flows built using the SigmaStudio™ graphical programming software from Analog Devices, Inc. The values stored in the parameter RAM

control individual signal processing blocks. The ADAU1777 also has a self boot function that can load the program RAM, parameter RAM, and register settings on power-up using an external EEPROM.

The SigmaStudio software programs and controls the core through the I²C or SPI control port. Along with aiding in the design and tuning of a signal flow, SigmaStudio can configure all of the ADAU1777 registers. The SigmaStudio graphical interface allows anyone with digital or analog audio processing knowledge to easily design the DSP signal flow and port it to a target application. The interface also provides enough flexibility and programmability for an experienced DSP programmer to have in-depth control of the design. In SigmaStudio, the user can connect graphical blocks (such as biquad filters, volume controls, and arithmetic operations), compile the design, and load the program and parameter files into the ADAU1777 memory through the control port. SigmaStudio also allows the user to download the design to an external EEPROM for self boot operation. Signal processing blocks available in the provided libraries include the following:

- Single-precision biquad filters
- Second-order filters
- Absolute value and two-input adder
- Volume controls
- Limiter

The ADAU1777 can generate its internal clocks from a wide range of input clocks by using the on-board fractional PLL. The PLL accepts inputs from 8 MHz to 27 MHz. For standalone operation, the clock can be generated using the on-board crystal oscillator.

SYSTEM CLOCKING AND POWER-UP

CLOCK INITIALIZATION

The ADAU1777 can generate its clocks either from an externally provided clock or from a crystal oscillator. In both cases, the on-board PLL can be used or the clock can be fed directly to the core. When a crystal oscillator is used, it is desirable to use a 12.288 MHz crystal, and the crystal oscillator function must be enabled in the COREN bit (Address 0x00, Bit 0). If the PLL is used, it must always be set to output 24.576 MHz. The PLL can be bypassed if a clock of 12.288 MHz or 24.576 MHz is available in the system. Bypassing the PLL saves system power.

The CC_MDIV and CC_CDIV bits must not be changed after setup, but the CLKSRC bit can be switched while the core is running.

Set the CC_MDIV and CC_CDIV bits so that the core and internal master clock are always 12.288 MHz; for example, when using a 24.576 MHz external source clock or if using the PLL, it is necessary to use the internal divide by 2 (see Table 11).

Table 11. Clock Configuration Settings

CC_MDIV	CC_CDIV	Description
1	1	Divide the PLL/external clock by 1. Use these settings for a 12.288 MHz direct input clock source.
0	0	Divide the PLL/external clock by 2. Use these settings for a 24.576 MHz direct input clock source or if using the PLL.

PLL Bypass Setup

On power-up, the ADAU1777 exits an internal reset after 15 ms. The rate of the internal master clock must be set properly using the CC_MDIV bit in the clock control register (Address 0x00). When bypassing the PLL, the clock associated with MCLKIN must be either 12.288 MHz or 24.576 MHz. The internal master clock of the ADAU1777 is disabled until the COREN bit is asserted.

PLL Enabled Setup

The core clock of the ADAU1777 is disabled by the default setting of the COREN bit and must remain disabled during the PLL lock acquisition period. The user can poll the lock bit to determine when the PLL has locked. After lock is acquired, the ADAU1777 can be started by asserting the COREN bit. This bit enables the core clock for all the internal blocks of the ADAU1777.

To program the PLL during initialization or reconfiguration of the codec, use the following procedure:

1. Ensure that PLL_EN (Bit 7, Address 0x00) is set low.
2. Set or reset the PLL control registers (Address 0x01 to Address 0x05).
3. Enable the PLL using the PLL_EN bit.
4. Poll the PLL lock bit in Register 0x06.
5. Set the COREN bit in Register 0x00 after the PLL lock is acquired.

Control Port Access During Initialization

During the lock acquisition period, only Register 0x00 to Register 0x06 are accessible through the control port. A read or write to any other register is prohibited until the core clock enable bit and the lock bit are both asserted. After the CORE_RUN bit (Address 0x09) is set high, the following register bits must not be changed:

- ADC_0_1_SINC and ADC_2_3_SINC
- DAC_SOURCE0 and DAC_SOURCE1

If these bits must be changed after the ADAU1777 is running, the CORE_RUN bit first must be disabled.

PLL

The PLL uses the MCLKIN signal as a reference to generate the core clock. The PLL settings are set in Register 0x00 to Register 0x05. Depending on the MCLK frequency, the PLL must be set for either integer or fractional mode. The PLL can accept input frequencies in the range of 8 MHz to 27 MHz.

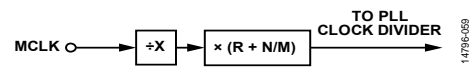

Figure 51. PLL Block Diagram

Input Clock Divider

Before reaching the PLL, the input clock signal goes through an integer clock divider to ensure that the clock frequency is within a suitable range for the PLL. The X bits in the PLL_CTRL4 register (Address 0x05, Bits[2:1]) set the PLL input clock divide ratio.

Integer Mode

Use integer mode when the clock input is an integer multiple of the PLL output.

For example, if MCLKIN = 12.288 MHz, $(X + 1) = 1$, and $f_s = 48$ kHz,

$$\text{PLL Required Output} = 24.576 \text{ MHz}$$

$$R/2 = 24.576 \text{ MHz}/12.288 \text{ MHz} = 2$$

where $R/2 = 2$ or $R = 4$.

In integer mode, the values set for N and M are ignored. Table 12 lists common integer PLL parameter settings for 48 kHz sampling rates.

Fractional Mode

Use fractional mode when the clock input is a fractional multiple of the PLL output.

For example, if MCLKIN = 13 MHz, $(X + 1) = 1$, and $f_s = 48$ kHz,

$$\text{PLL Required Output} = 24.576 \text{ MHz}$$

$$(1/2) \times (R + (N/M)) = 24.576 \text{ MHz}/13 \text{ MHz} = (1/2) \times (3 + (1269/1625))$$

where:

$$R = 3.$$

$$N = 1269.$$

$$M = 1625.$$

Table 13 lists common fractional PLL parameter settings for 48 kHz sampling rates. When the PLL is used in fractional mode, the N/M fraction must be kept in the range of 0.1 to 0.9 to ensure correct operation of the PLL.

The PLL output clock must be kept in the range of 20.5 MHz to 27 MHz, which must be taken into account when calculating PLL values and MCLK frequencies.

CLOCK OUTPUT

Use the CLKOUT pin as a master clock output to clock other ICs in the system or as the clock for the digital microphone inputs and PDM output. This clock can be generated from the 12.288 MHz master clock of the ADAU1777 by factors of 2, 1, 1/2, 1/4, and 1/8. If PDM mode is enabled, only the 1/2, 1/4, and 1/8 settings produce a clock signal on CLKOUT. The factor of 2 multiplier works properly only if the input clock was previously divided by 2 using the CC_MDIV bit.

POWER SEQUENCING

AVDD and IOVDD can each be set to any voltage between 1.8 V and 3.3 V, and DVDD can be set between 1.1 V and 1.8 V or between 1.1 V and 1.2 V if using the on-board regulator.

On power-up, AVDD must be powered up before or at the same time as IOVDD. Do not power up IOVDD when power is not applied to AVDD.

Enabling the $\overline{\text{PD}}$ pin powers down all analog and digital circuits. Before enabling PD (that is, setting it low), be sure to mute the outputs to avoid any pops when the IC is powered down. Tie PD directly to IOVDD for normal operation.

Power-Down Considerations

When powering down the ADAU1777, mute the outputs before AVDD power is removed; otherwise, pops or clicks may be heard. The easiest way to achieve this is to use a regulator that has a power-good (PGOOD) signal to power the ADAU1777 or to generate a power-good signal using additional circuitry external to the regulator itself. Typically, on such regulators, the power-good signal changes state when the regulated voltage drops below ~90% of its target value. Connect this power-good signal to one of the ADAU1777 multipurpose pins and mute the DAC outputs by setting the multipurpose pin functionality to mute both DACs in Register 0x38 to Register 0x3E. Taking these precautions ensures that the outputs are muted before power is completely removed.

Table 12. Integer PLL Parameter Settings for PLL Output = 24.576 MHz

MCLK Input (MHz)	Input Divider (X + 1)	Integer (R)	Denominator (M)	Numerator (N)	PLL_CTRL4 Settings (Address 0x05)
12.288	1	4	Don't care	Don't care	0x20
24.576	1	2	Don't care	Don't care	0x10

Table 13. Fractional PLL Parameter Settings for PLL Output = 24.576 MHz

MCLK Input (MHz)	Input Divider (X + 1)	Integer (R)	Denominator (M)	Numerator (N)	PLL Parameter Register Settings (Address 0x05 to Address 0x01)				
					PLL_CTRL4 (Addr. 0x05)	PLL_CTRL3 (Addr. 0x04)	PLL_CTRL2 (Addr. 0x03)	PLL_CTRL1 (Addr. 0x02)	PLL_CTRL0 (Addr. 0x01)
8	1	6	125	18	0x31	0x12	0x00	0x7D	0x00
13	1	3	1625	1269	0x19	0xF5	0x04	0x59	0x06
14.4	2	6	75	62	0x33	0x3E	0x00	0x4B	0x00
19.2	2	5	25	3	0x2B	0x03	0x00	0x19	0x00
26	2	3	1625	1269	0x1B	0xF5	0x04	0x59	0x06
27	2	3	1125	721	0x1B	0xD1	0x02	0x65	0x04

SIGNAL ROUTING

The ADAU1777 features flexible signal routing. The signal routing is specified by Register 0x0F through Register 0x1A.

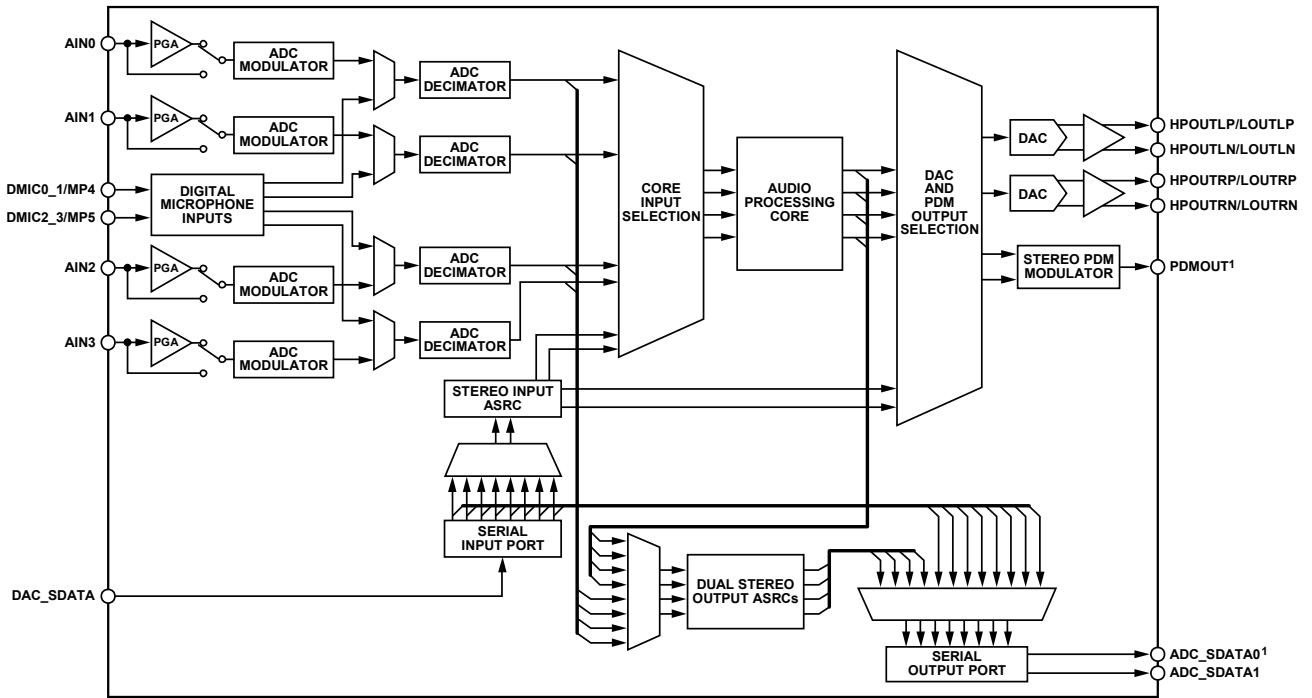

¹THE ADC_SDATA0 AND PDMOUT FUNCTIONS SHARE A PHYSICAL PIN; THEREFORE ONLY ONE OF THESE FUNCTIONS CAN BE USED AT A TIME.

Figure 52. Input and Output Signal Routing

14796-000

INPUT SIGNAL PATHS

Four input paths, from either an ADC or a digital microphone, can be routed to the core. The input sources (ADC or digital microphone) must be configured in pairs (for example, 0 and 1, or 2 and 3), but each channel can be routed individually. The core inputs can also be sourced from a stereo input ASRC.

ANALOG INPUTS

The ADAU1777 can accept both line level and microphone inputs. Each of the four analog input channels can be configured in single-ended mode or a single-ended with PGA mode. There are also inputs for up to four digital microphones. The analog inputs are biased at $AVDD/2$ V. Connect unused input pins to the CM pin or ac-couple them to ground.

Signal Polarity

Signals routed through the PGAs are inverted. As a result, signals input through the PGA are output from the ADCs with a polarity that is opposite that of the input. Single-ended inputs are not inverted. The ADCs are noninverting.

Input Impedance

The input impedance of the analog inputs varies with the gain of the PGA. This impedance ranges from 0.68 k Ω at the +35.25 dB gain setting to 32.0 k Ω at the -12 dB setting. The resistors inside the ADAU1777 are precisely matched to each other, resulting in very little gain error. However, the exact value of the resistors depends on various conditions in the silicon manufacturing process and can vary by as much as $\pm 20\%$. The input impedance (R_{IN}) on each pin can be calculated as follows:

$$R_{IN} = \frac{40}{10^{(Gain/20)} + 1} \text{ k}\Omega$$

where *Gain* is set by PGA_GAINx.

The optional 10 dB PGA boost, set in the PGA_x_BOOST bits, does not affect the input impedance. This setting is an alternative way of increasing gain without decreasing input impedance; however, it causes some degradation in performance.

Analog Microphone Inputs

For microphone signals, the ADAU1777 analog inputs can be configured as single-ended with PGA mode.

The PGA settings are controlled in Register 0x23 to Register 0x26. The PGA is enabled by setting the PGA_ENx bits.

Connect the microphone signal to the inverting inputs of the PGAs (AINx), as shown in Figure 53.

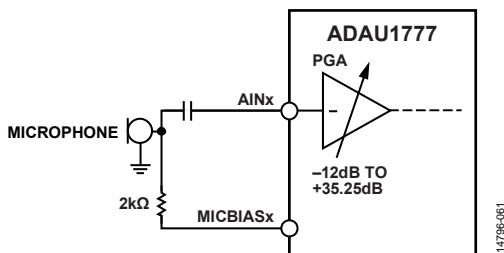

Figure 53. Single-Ended Microphone Configuration

Analog Line Inputs

Line level signals can be input on the AINx pins of the analog inputs. Figure 54 shows a single-ended line input using the AINx pins.

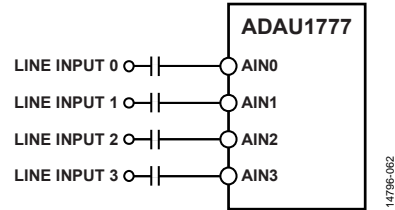

Figure 54. Single-Ended Line Inputs

Precharging Input Capacitors

Precharge amplifiers are enabled by default to charge large series capacitors quickly on the inputs and outputs. Precharging these capacitors prevents pops in the audio signal. The precharge circuits are powered up by default on startup and can be disabled in the POP_SUPPRESS register. The precharge amplifiers are automatically disabled when the PGA or headphone amplifiers are enabled. For unused PGAs and headphone outputs, disable these precharge amplifiers using the POP_SUPPRESS register. The precharging time is dependent on the input/output series capacitors. The impedance looking into the AINx pin is 500 Ω in this mode. However, at startup, the impedance looking into the pin is dominated by the time constant of the CM pin because the precharge amplifiers reference the CM voltage.

Microphone Bias

The ADAU1777 includes two microphone bias outputs: MICBIAS0 and MICBIAS1. These pins provide a voltage reference for electret analog microphones. The MICBIASx pins also cleanly supply voltage to digital or analog microelectromechanical systems (MEMS) microphones with separate power supply pins. The MICBIASx voltage is set in the microphone bias control register (Address 0x2D). Using this register, the MICBIAS0 or MICBIAS1 output can be enabled or disabled. The gain options provide two possible voltages: $0.65 \times AVDD$ or $0.90 \times AVDD$.

Many applications require enabling only one of the two bias outputs. The two bias outputs must both be enabled when many microphones are used in the system or when the positioning of the microphones on the PCB does not allow one pin to bias all microphones.

DIGITAL MICROPHONE INPUT

When using a digital microphone connected to the DMIC0_1/MP4 and DMIC2_3/MP5 pins, the DCM_0_1 and DCM_2_3 bits in Register 0x1D and Register 0x1E must be set to enable the digital microphone signal paths. Set the pin functions to digital microphone input in the corresponding pin mode registers (Address 0x3C and Address 0x3D). The DMIC0/DMIC2 and DMIC1/DMIC3 channels can be swapped (left/right swap) by writing to the DMIC_SW0 and DMIC_SW1 bits in the ADC_CONTROL2 and ADC_CONTROL3 registers (Address 0x1D and Address 0x1E, respectively). In addition, the microphone polarity can be reversed by setting the DMIC_POLx bits, which reverses the phase of the incoming audio by 180°.

The digital microphone inputs are clocked from the CLKOUT pin. The digital microphone data stream must be clocked by this pin and not by a clock from another source, such as another audio IC, even if the other clock is of the same frequency as CLKOUT.

The digital microphone signal bypasses the analog input path and the ADCs and is routed directly into the decimation filters. The digital microphone and the ADCs share digital filters and, therefore, both cannot be used simultaneously. The digital microphone inputs are enabled in pairs. The ADAU1777 inputs can be set for either four analog inputs, four digital microphone inputs, or two analog inputs and two digital microphone inputs. Figure 55 shows the digital microphone interface and signal routing.

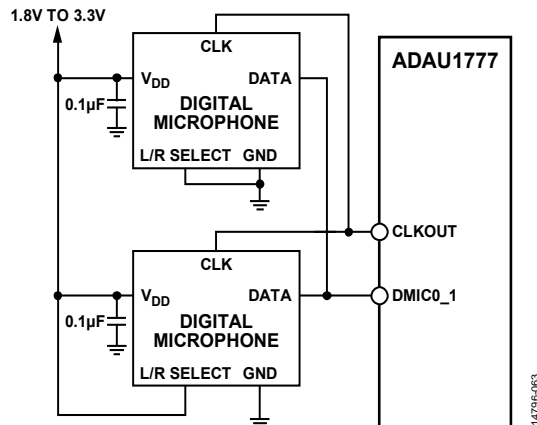

Figure 55. Digital Microphone Interface Block Diagram

Figure 55 shows two digital microphones connected to the DMIC0_1/MP4 pin. These microphones can also be connected to DMIC2_3/MP5 if that signal path is to be used for digital microphones. If more than two digital microphones are to be used in a system, then up to two microphones are connected to both DMIC0_1/MP4 and DMIC2_3/MP5 and the CLKOUT signal is fanned out to the clock input of all of the microphones.

ANALOG-TO-DIGITAL CONVERTERS (ADCs)

The ADAU1777 includes four 24-bit, Σ - Δ ADCs, each with a selectable sample rate of 768 kHz, 192 kHz, or 96 kHz.

ADC Full-Scale Level

The full-scale input to the ADCs (0 dBFS) scales linearly with AVDD. At AVDD = 3.3 V, the full-scale input level is 1 V rms. Signal levels greater than the full-scale value cause the ADCs to clip.

Digital ADC Volume Control

The volume setting of each ADC can be digitally attenuated in the ADCx_VOLUME registers (Address 0x1F to Address 0x22). The volume can be set between 0 dB and -95.625 dB in 0.375 dB steps. The ADC volume can also be digitally muted in the ADC_CONTROLx registers (Address 0x1B to Address 0x1E).

High-Pass Filter

A high-pass filter is available on the ADC path to remove dc offsets; this filter can be enabled or disabled using the HP_x_y_EN bits. At $f_s = 192$ kHz, the corner frequency of this high-pass filter can be set to 1 Hz, 4 Hz, or 8 Hz.

OUTPUT SIGNAL PATHS

Data from the serial input port can be routed to the core, to the output selection multiplexer, or directly to the serial output ports. Data from the core can be routed to the serial output port, the stereo DAC, and the stereo PDM modulator (see Figure 52).

The analog outputs of the ADAU1777 can be configured as differential or single-ended outputs. The analog output pins can drive headphone or earpiece speakers. The line outputs can drive a load of at least 10 k Ω or can be set into headphone mode to drive headphones or earpiece speakers. The analog output pins are biased at AVDD/2.

ANALOG OUTPUTS

Headphone Output

The output pins can be driven by either a line output driver or a headphone driver by setting the HP_EN_L and HP_EN_R bits in the headphone line output select register (Address 0x43). The headphone outputs can drive a load of at least 16 Ω .

Headphone Output Power-Up Sequencing

To prevent pops when turning on the headphone outputs, wait at least 6 ms to unmute these outputs after enabling the headphone output using the HP_EN_x bits. Waiting 6 ms allows an internal capacitor to charge before these outputs are used. Figure 56 illustrates the headphone output power-up sequencing.

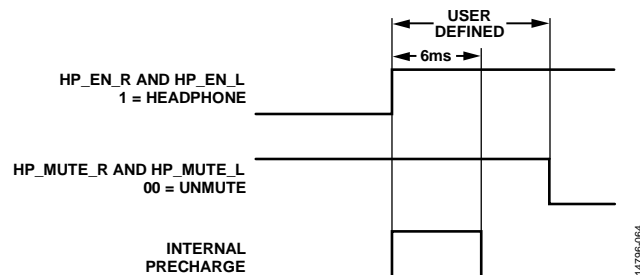

Figure 56. Headphone Output Power-Up Sequencing

Ground Centered Headphone Configuration

The headphone outputs can also be configured as ground centered outputs by connecting coupling capacitors in series with the output pins. Ground centered headphones must use the AGND pin as the ground reference.

When the headphone outputs are configured as ground centered, the capacitors create a high-pass filter on the outputs. The corner frequency of this filter ($f_{3\text{ dB}}$), which has an attenuation of 3 dB, is calculated by the following formula:

$$f_{3\text{ dB}} = 1/(2\pi \times R \times C)$$

where :

R is the impedance of the headphones.

C is the capacitor value.

For a typical headphone impedance of 32 Ω with a 220 μF capacitor, the corner frequency is 23 Hz.

Pop and Click Suppression

On power-up, the precharge circuitry is enabled on all four analog output pins to suppress pops and clicks. After power-up, the precharge circuitry can be set to a low power mode using the HP_POP_DISx bits in the POP_SUPPRESS register (Address 0x29).

The precharge time depends on the value of the capacitor connected to the CM pin and the RC time constant of the load on the output pin. For a typical line output load, the precharge time is between 2 ms and 3 ms. After this precharge time, the HP_POP_DISx bits can be set to low power mode.

To avoid clicks and pops, mute all analog outputs that are in use while changing any register settings that may affect the signal path. These outputs can then be unmuted after the changes are made.

Line Outputs

The analog output pins (HPOUTLP/LOUTLP, HPOUTLN/LOUTLN, HPOUTRP/LOUTRP, and HPOUTRN/LOUTRN) can be used to drive both differential and single-ended loads. In their default settings, these pins can drive typical line loads of 10 k Ω or greater.

When the line output pins are used in single-ended mode, use the HPOUTLP/LOUTLP and HPOUTRP/LOUTRP pins to output the signals, and power down the HPOUTLN/LOUTLN and HPOUTRN/LOUTRN pins.

DIGITAL-TO-ANALOG CONVERTERS (DACs)

The ADAU1777 includes two 24-bit, Σ - Δ DACs.

DAC Full-Scale Level

The full-scale output from the DACs (0 dBFS) scales linearly with AVDD. At AVDD = 3.3 V, the full-scale output level is 1.94 V rms for a differential output or 0.97 V rms for a single-ended output.

Digital DAC Volume Control

The volume of each DAC can be digitally attenuated using the DACx_VOLUME registers (Address 0x2F and Address 0x30). The volume can be set to be between 0 dB and -95.625 dB in 0.375 dB steps.

PDM OUTPUT

The ADAU1777 includes a 2-channel PDM modulator. The PDMOUT pin can be used to drive a PDM input amplifier, such as the SSM2517 mono 2.4 W amplifier. Two SSM2517 devices can be connected to the PDMOUT data stream to enable a stereo output. The PDM output signal is clocked by the CLKOUT pin output. The PDM output stream must be clocked by this pin and not by a clock from another source, such as another audio IC, even if the other clock is of the same frequency as CLKOUT. The PDM output data is clipped at the -6 dB level to prevent overdriving a connected amplifier like the SSM2517.

The ADAU1777 has the ability to output PDM control patterns to configure devices such as the SSM2517. Each pattern is a byte long and is written with a user defined pattern in the PDM_PATTERN register (Address 0x37). The control pattern is enabled and the output channel selection is configured in the PDM_OUT register (Address 0x36). The PDM pattern must not be changed while the ADAU1777 is outputting the control pattern to the external device. After the external device is configured, the control pattern can be disabled. For the SSM2517, the control pattern must be repeated a minimum of 128 times to configure the device. Table 14 describes typical control patterns for the SSM2517.

Table 14. SSM2517 PDM Control Pattern Descriptions

Pattern	Control Description
0xAC	Power-down. All blocks off except for the PDM interface. Normal start-up time.
0xD8	Gain optimized for PVDD = 5 V operation. Overrides GAIN_FS pin setting.
0xD4	Gain optimized for PVDD = 3.6 V operation. Overrides GAIN_FS pin setting.
0xD2	Gain optimized for PVDD = 2.5 V operation. Overrides GAIN_FS pin setting.
0xD1	f_s set to opposite value determined by GAIN_FS pin.
0xE1	Ultralow electromagnetic interference (EMI) mode.
0xE2	Half clock cycle pulse mode for power savings.
0xE4	Special 32 kHz, $128 \times f_s$ operation mode.

ASYNCHRONOUS SAMPLE RATE CONVERTERS

The ADAU1777 includes ASRCs to enable synchronous, full duplex operation of the serial ports. Two stereo ASRCs are available for the digital outputs, and one stereo ASRC is available for the digital input signals.

The ASRCs can convert serial output data from the core rates to the serial port rates of 192 kHz down to less than 8 kHz. All intermediate frequencies and ratios are also supported.

SIGNAL LEVELS

The ADCs, DACs, and ASRCs have fixed gain settings that must be considered when configuring the system. These settings are chosen to maximize performance of the converters and to ensure that there is 0 dB gain for any signal path from the input of the ADAU1777 to its output. Therefore, the full-scale level of a signal in the processing core is slightly different from a full-scale level external to the IC.

Input paths, such as through the ADCs and input ASRCs, are scaled by 0.75, or about -2.5 dB. Output paths, such as through the DACs or output ASRCs, are scaled by 1.33, or about $+2.5$ dB. This scaling is shown in Figure 57.

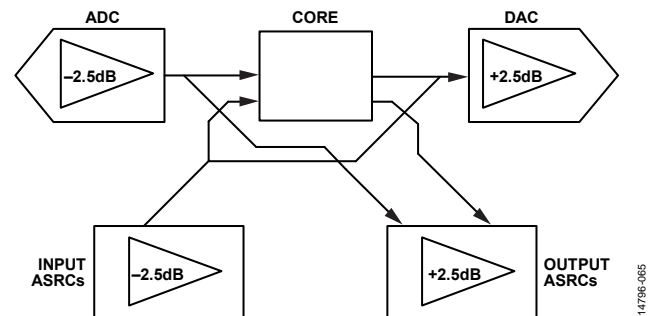

Figure 57. Signal Level Diagram

Because of this input and output scaling, output signals from the core must be limited to -2.5 dB full scale to prevent the DACs and ASRCs from clipping.

SIGNAL PROCESSING

The ADAU1777 processing core is optimized for ANC processing. The processing capabilities of the core include biquad filters, limiters, volume controls, and mixing. The core has four inputs and four outputs. The core is controlled with a 10-bit program word, with a maximum of 32 instructions per frame.

INSTRUCTIONS

A complete list of instructions/processing blocks along with documentation can be found in the SigmaStudio software for the ADAU1777. The processing blocks available are

- Single precision biquad/second-order filters
- Absolute value
- Two-input addition
- T connection in SigmaStudio
- Limiter with/without external detector loop
- Linear gain
- Volume slider
- Mute
- DBREG level detection

DATA MEMORY

The ADAU1777 data path is 26 bits (5.21 format). The data memory is 32 words of 2 × 26 bits. The double length memory enables the core to double precision arithmetic with double length data and single length coefficients.

PARAMETERS

Parameters, such as filter coefficients, limiter settings, and volume control settings, are saved in parameter registers. Each parameter is a 32-bit number. The format of this number depends on whether it is controlling a filter or a limiter. The number formats of different parameters are shown in Table 15. When the parameter formats use less than the full 32-bit memory space, as with the limiter parameters, the data is LSB aligned.

Table 15. Parameter Number Formats

Parameter Type	Format
Filter Coefficient (B0, B1, B2)	5.27
Filter Coefficient (A1)	2.27 (sign extended)
Filter Coefficient (A2)	1.27 (sign extended)
Maximum Gain	2.23
Minimum Gain	2.23
Attack Time	24.0
Decay Time	24.0
Threshold	2.23

Two parameter banks are available. Each bank can hold a full set of 160 parameters (32 filters × 5 coefficients). Users can switch between Bank A and Bank B, allowing two sets of parameters to be saved in memory and switched on-the-fly while the codec is running. Bank switching can be achieved by writing to

the CORE_CONTROL register (Address 0x09) or by using the multipurpose push-button switches, but not by using a combination of the two. Parameters in the active bank must not be updated while the core is running; doing so may result in noises on the outputs.

Parameters are assigned to instructions in the order in which the instructions are instantiated in the code. The instruction types that use parameters are the biquad filters and limiters.

Table 17 shows the addresses of each parameter in Bank A that are associated with each of the 32 instructions, and Table 18 shows the addresses of each parameter in Bank B. Table 16 shows the addresses of the LSB aligned, 10-bit program words.

Table 16. Program Addresses

Instruction	Instruction Address
0	0x0080
1	0x0081
2	0x0082
3	0x0083
4	0x0084
5	0x0085
6	0x0086
7	0x0087
8	0x0088
9	0x0089
10	0x008A
11	0x008B
12	0x008C
13	0x008D
14	0x008E
15	0x008F
16	0x0090
17	0x0091
18	0x0092
19	0x0093
20	0x0094
21	0x0095
22	0x0096
23	0x0097
24	0x0098
25	0x0099
26	0x009A
27	0x009B
28	0x009C
29	0x009D
30	0x009E
31	0x009F

Table 17. Parameter Addresses, Bank A

Assignment Order	B0/Maximum Gain	B1/Minimum Gain	B2/Attack	A1/Decay	A2/Threshold
0	0x00E0	0x0100	0x0120	0x0140	0x0160
1	0x00E1	0x0101	0x0121	0x0141	0x0161
2	0x00E2	0x0102	0x0122	0x0142	0x0162
3	0x00E3	0x0103	0x0123	0x0143	0x0163
4	0x00E4	0x0104	0x0124	0x0144	0x0164
5	0x00E5	0x0105	0x0125	0x0145	0x0165
6	0x00E6	0x0106	0x0126	0x0146	0x0166
7	0x00E7	0x0107	0x0127	0x0147	0x0167
8	0x00E8	0x0108	0x0128	0x0148	0x0168
9	0x00E9	0x0109	0x0129	0x0149	0x0169
10	0x00EA	0x010A	0x012A	0x014A	0x016A
11	0x00EB	0x010B	0x012B	0x014B	0x016B
12	0x00EC	0x010C	0x012C	0x014C	0x016C
13	0x00ED	0x010D	0x012D	0x014D	0x016D
14	0x00EE	0x010E	0x012E	0x014E	0x016E
15	0x00EF	0x010F	0x012F	0x014F	0x016F
16	0x00F0	0x0110	0x0130	0x0150	0x0170
17	0x00F1	0x0111	0x0131	0x0151	0x0171
18	0x00F2	0x0112	0x0132	0x0152	0x0172
19	0x00F3	0x0113	0x0133	0x0153	0x0173
20	0x00F4	0x0114	0x0134	0x0154	0x0174
21	0x00F5	0x0115	0x0135	0x0155	0x0175
22	0x00F6	0x0116	0x0136	0x0156	0x0176
23	0x00F7	0x0117	0x0137	0x0157	0x0177
24	0x00F8	0x0118	0x0138	0x0158	0x0178
25	0x00F9	0x0119	0x0139	0x0159	0x0179
26	0x00FA	0x011A	0x013A	0x015A	0x017A
27	0x00FB	0x011B	0x013B	0x015B	0x017B
28	0x00FC	0x011C	0x013C	0x015C	0x017C
29	0x00FD	0x011D	0x013D	0x015D	0x017D
30	0x00FE	0x011E	0x013E	0x015E	0x017E
31	0x00FF	0x011F	0x013F	0x015F	0x017F

Table 18. Parameter Addresses, Bank B

Assignment Order	B0/Maximum Gain	B1/Minimum Gain	B2/Attack	A1/Decay	A2/Threshold
0	0x0180	0x01A0	0x01C0	0x01E0	0x0200
1	0x0181	0x01A1	0x01C1	0x01E1	0x0201
2	0x0182	0x01A2	0x01C2	0x01E2	0x0202
3	0x0183	0x01A3	0x01C3	0x01E3	0x0203
4	0x0184	0x01A4	0x01C4	0x01E4	0x0204
5	0x0185	0x01A5	0x01C5	0x01E5	0x0205
6	0x0186	0x01A6	0x01C6	0x01E6	0x0206
7	0x0187	0x01A7	0x01C7	0x01E7	0x0207
8	0x0188	0x01A8	0x01C8	0x01E8	0x0208
9	0x0189	0x01A9	0x01C9	0x01E9	0x0209
10	0x018A	0x01AA	0x01CA	0x01EA	0x020A
11	0x018B	0x01AB	0x01CB	0x01EB	0x020B
12	0x018C	0x01AC	0x01CC	0x01EC	0x020C
13	0x018D	0x01AD	0x01CD	0x01ED	0x020D
14	0x018E	0x01AE	0x01CE	0x01EE	0x020E
15	0x018F	0x01AF	0x01CF	0x01EF	0x020F

Assignment Order	B0/Maximum Gain	B1/Minimum Gain	B2/Attack	A1/Decay	A2/Threshold
16	0x0190	0x01B0	0x01D0	0x01F0	0x0210
17	0x0191	0x01B1	0x01D1	0x01F1	0x0211
18	0x0192	0x01B2	0x01D2	0x01F2	0x0212
19	0x0193	0x01B3	0x01D3	0x01F3	0x0213
20	0x0194	0x01B4	0x01D4	0x01F4	0x0214
21	0x0195	0x01B5	0x01D5	0x01F5	0x0215
22	0x0196	0x01B6	0x01D6	0x01F6	0x0216
23	0x0197	0x01B7	0x01D7	0x01F7	0x0217
24	0x0198	0x01B8	0x01D8	0x01F8	0x0218
25	0x0199	0x01B9	0x01D9	0x01F9	0x0219
26	0x019A	0x01BA	0x01DA	0x01FA	0x021A
27	0x019B	0x01BB	0x01DB	0x01FB	0x021B
28	0x019C	0x01BC	0x01DC	0x01FC	0x021C
29	0x019D	0x01BD	0x01DD	0x01FD	0x021D
30	0x019E	0x01BE	0x01DE	0x01FE	0x021E
31	0x019F	0x01BF	0x01DF	0x01FF	0x021F

CONTROL PORT

The ADAU1777 has both a 4-wire SPI control port and a 2-wire I²C bus control port. Each port can be used to set the memories and registers. The IC defaults to I²C mode but can be put into SPI control mode by pulling the \overline{SS} pin low three times.

The control port is capable of full read/write operation for all addressable memories and registers. Most signal processing parameters are controlled by writing new values to the parameter memories using the control port. Other functions, such as mute and input/output mode control, are programmed through the registers.

All addresses can be accessed in either single address mode or burst mode. The first byte (Byte 0) of a control port write contains the 7-bit IC address plus the R/W bit. The next two bytes (Byte 1 and Byte 2) are the 16-bit subaddress of the memory or register location within the ADAU1777. All subsequent bytes (starting with Byte 3) contain the data, such as register data, program data, or parameter data. The number of bytes per word depends on the type of data that is being written. Table 19 shows the word length of the different data types of the ADAU1777. The exact formats for specific types of writes are shown in Figure 60 and Figure 61.

Table 19. Data-Word Sizes

Data Type	Word Size (Bytes)
Registers	1
Program	2
Parameters	4

If large blocks of data must be downloaded to the ADAU1777, halt the output of the core (using the CORE_RUN bit in the core control register (Address 0x09)), load new data, and then restart the core. Halting the core is typically done during the booting sequence at startup or when loading a new program into memory.

Registers and bits shown as reserved in the register map read back 0s. When writing to these registers and bits, such as during a burst write across a reserved register, or when writing to reserved bits in a register with other used bits, write 0s.

The control port pins are multifunctional, depending on the mode in which the device is operating. Table 20 details these multiple functions.

Table 20. Control Port Pin Functions

Pin	I ² C Mode	SPI Mode
SCL/SCLK	SCL, input	SCLK, input
SDA/MISO	SDA, open-collector output	MISO, output
ADDR1/MOSI	I ² C Address Bit 1, input	MOSI, input
ADDR0/ \overline{SS}	I ² C Address Bit 0, input	\overline{SS} , input

BURST MODE COMMUNICATION

Use burst mode addressing, in which the subaddresses are automatically incremented at word boundaries, for writing large amounts of data to contiguous memory locations. This increment occurs automatically after a single-word write unless the control port communication is stopped; that is, a stop condition is issued for I²C mode, or \overline{SS} is brought high for SPI mode. The registers and RAMs in the ADAU1777 range in width from one to four bytes; therefore, the auto-increment feature knows the mapping between subaddresses and the word length of the destination register (or memory location).

I²C PORT

The ADAU1777 supports a 2-wire serial (I²C-compatible) micro-processor bus driving multiple peripherals. I²C mode uses two pins—serial data (SDA) and serial clock (SCL)—to carry data between the ADAU1777 and the system I²C master controller. In I²C mode, the ADAU1777 is always a slave on the bus, except when the IC is self booting. See the Self Boot section for details about using the ADAU1777 in self boot mode.

Each slave device is recognized by a unique 7-bit address. The ADAU1777 I²C address format is shown in Table 21. The LSB of this first byte sent from the I²C master sets either a read or write operation. Logic Level 1 corresponds to a read operation, and Logic Level 0 corresponds to a write operation.

The ADDR0 and ADDR1 pins set the LSBs of the I²C address (see Table 22); therefore, each ADAU1777 can be set to one of four unique addresses. This feature allows multiple ICs to exist on the same I²C bus without address contention. The 7-bit I²C addresses are shown in Table 22.

An I²C data transfer is always terminated by a stop condition.

Both SDA and SCL must have 2.0 k Ω pull-up resistors on the lines connected to them. The voltage on these signal lines must not be higher than IOVDD.

Table 21. I²C Address Format

Bit 6	Bit 5	Bit 4	Bit 3	Bit 2	Bit 1	Bit 0
0	1	1	1	1	ADDR1	ADDR0

Table 22. I²C Addresses

ADDR1	ADDR0	Slave Address
0	0	0x3C
0	1	0x3D
1	0	0x3E
1	1	0x3F

Addressing

Initially, each device on the I²C bus is in an idle state and monitoring the SDA and SCL lines for a start condition and the proper address. The I²C master initiates a data transfer by establishing a start condition, defined by a high to low transition on SDA while SCL remains high. This condition indicates that an address/data stream follows. All devices on the bus respond to the start condition and shift the next eight bits (the 7-bit address plus the R/W bit) MSB first. The device that recognizes the transmitted address responds by pulling the data line low during the ninth clock pulse. This ninth bit is an acknowledge bit. All other devices withdraw from the bus at this point and return to the idle condition. The R/W bit determines the direction of the data. A Logic 0 on the LSB of the first byte indicates that the master is writing information to the peripheral, whereas a Logic 1 indicates that the master is reading information from the peripheral after writing the subaddress and repeating the start address. A data transfer occurs until a stop condition is encountered. A stop condition occurs when SDA transitions from low to high while SCL is held

high. Figure 58 shows the timing of an I²C write, and Figure 59 shows the timing of an I²C read.

Stop and start conditions can be detected at any stage during the data transfer. If these conditions are asserted out of sequence with normal read and write operations, the ADAU1777 immediately jumps to the idle condition. During a given SCL high period, the user must issue only one start condition, one stop condition, or a single stop condition followed by a single start condition. If the user issues an invalid subaddress, the ADAU1777 does not issue an acknowledge and returns to the idle condition. If the user exceeds the highest subaddress while in auto-increment mode, one of two actions is taken. In read mode, the ADAU1777 outputs the highest subaddress register contents until the master device issues a no acknowledge, indicating the end of a read. A no acknowledge condition is where the SDA line is not pulled low on the ninth clock pulse on SCL. If the highest subaddress location is reached while in write mode, the data for the invalid byte is not loaded into any subaddress register, a no acknowledge is issued by the ADAU1777, and the device returns to the idle condition.

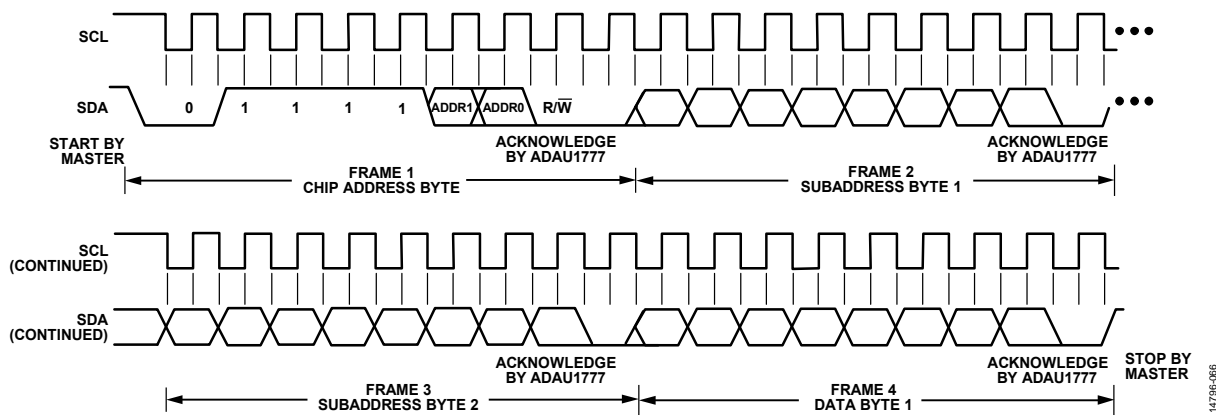

Figure 58. I²C Write to ADAU1777 Clcking

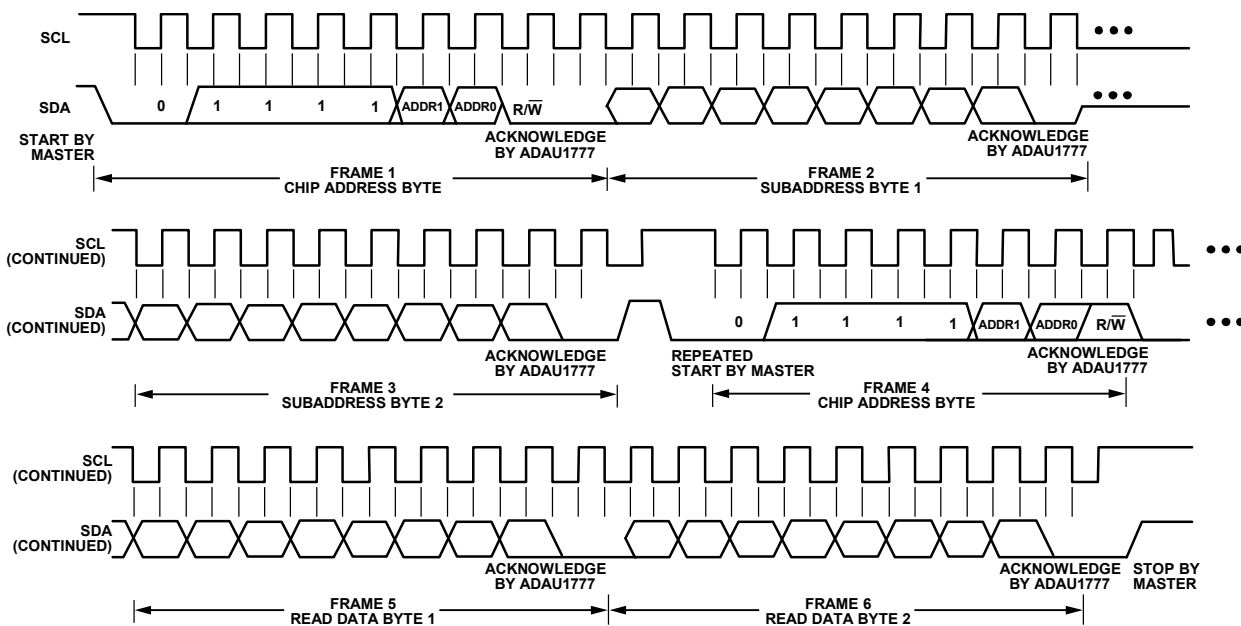

Figure 59. I²C Read from ADAU1777 Clcking

I²C Read and Write Operations

Figure 60 shows the format of a single-word write operation. Every ninth clock pulse, the ADAU1777 issues an acknowledge by pulling SDA low.

Figure 61 shows the format of a burst mode write sequence. This figure shows an example where the target destination words are two bytes, such as the program memory. The ADAU1777 knows to increment its subaddress register every two bytes because the requested subaddress corresponds to a register or memory area with a 2-byte word length.

The format of a single-word read operation is shown in Figure 62. Note that the first R/W bit is 0, indicating a write operation because the subaddress still must be written to set up the internal address. After the ADAU1777 acknowledges the receipt of the subaddress, the master must issue a repeated start command followed by the chip address byte with the R/W set to 1 (read). This command causes the SDA pin to reverse and begin driving

data back to the master. The master then responds every ninth pulse with an acknowledge pulse to the ADAU1777.

Figure 63 shows the format of a burst mode read sequence. This figure shows an example where the target read words are two bytes. The ADAU1777 increments its subaddress every two bytes because the requested subaddress corresponds to a register or memory area with word lengths of two bytes. Other address ranges may have a variety of word lengths, ranging from one to four bytes. The ADAU1777 always decodes the subaddress and sets the auto-increment circuit so that the address increments after the appropriate number of bytes.

Figure 60 to Figure 63 use the following abbreviations:

- S = start bit
- P = stop bit
- AM = acknowledge by master
- AS = acknowledge by slave

S	I ² C ADDRESS, R/W = 0	AS	SUBADDRESS HIGH	AS	SUBADDRESS LOW	AS	DATA BYTE 1	AS	DATA BYTE 2	...	AS	DATA BYTE N	P
---	-----------------------------------	----	-----------------	----	----------------	----	-------------	----	-------------	-----	----	-------------	---

Figure 60. Single-Word I²C Write Format

14796-089

S	I ² C ADDRESS, R/W = 0	AS	SUBADDRESS HIGH	AS	SUBADDRESS LOW	AS	DATA-WORD 1, BYTE 1	AS	DATA-WORD 1, BYTE 2	AS	DATA-WORD 2, BYTE 1	AS	DATA-WORD 2, BYTE 2	AS	...	P
---	-----------------------------------	----	-----------------	----	----------------	----	---------------------	----	---------------------	----	---------------------	----	---------------------	----	-----	---

Figure 61. Burst Mode I²C Write Format

14796-089

S	I ² C ADDRESS, R/W = 0	AS	SUBADDRESS HIGH	AS	SUBADDRESS LOW	AS	S	I ² C ADDRESS, R/W = 1	AS	DATA BYTE 1	AM	DATA BYTE 2	...	AM	DATA BYTE N	P
---	-----------------------------------	----	-----------------	----	----------------	----	---	-----------------------------------	----	-------------	----	-------------	-----	----	-------------	---

Figure 62. Single-Word I²C Read Format

14796-070

S	I ² C ADDRESS, R/W = 0	AS	SUBADDRESS HIGH	AS	SUBADDRESS LOW	AS	S	I ² C ADDRESS, R/W = 1	AS	DATA-WORD 1, BYTE 1	AM	DATA-WORD 1, BYTE 2	AM	...	P
---	-----------------------------------	----	-----------------	----	----------------	----	---	-----------------------------------	----	---------------------	----	---------------------	----	-----	---

Figure 63. Burst Mode I²C Read Format

14796-071

SPI PORT

By default, the ADAU1777 is in I²C mode, but it can be put into SPI control mode by pulling \overline{SS} low three times. The device can be configured for SPI mode by issuing three SPI writes, which are in turn ignored by the ADAU1777. The next (fourth) SPI write is then latched into the SPI port.

The SPI port uses a 4-wire interface—consisting of the \overline{SS} , SCLK, MOSI, and MISO signals—and is always a slave port. The \overline{SS} signal goes low at the beginning of a transaction and high at the end of a transaction. The SCLK signal latches MOSI on a low to high transition. MISO data is shifted out of the ADAU1777 on the falling edge of SCLK and must be clocked into a receiving device, such as a microcontroller, on the SCLK rising edge. The MOSI signal carries the serial input data, and the MISO signal is the serial output data. The MISO signal remains tristated until a read operation is requested. Tristating allows other SPI-compatible peripherals to share the same readback line.

All SPI transactions have the same basic format shown in Table 23. Timing diagrams are shown in Figure 64 and Figure 65. All data is written MSB first. The ADAU1777 can be taken out of SPI mode only by pulling the \overline{PD} pin low or by powering down the IC.

Read/Write

The first byte of an SPI transaction indicates whether the communication is a read or a write with the R/W bit. The LSB of this first byte determines whether the SPI transaction is a read (Logic Level 1) or a write (Logic Level 0).

Subaddress

The 16-bit subaddress word is decoded into a location of one of the memories or registers. This subaddress is the location of the appropriate memory location or register.

Data Bytes

The number of data bytes varies according to the register or memory being accessed. During a burst mode write, an initial subaddress is written followed by a continuous sequence of data for consecutive memory/register locations.

A sample clocking diagram for a single write SPI operation to the parameter RAM is shown in Figure 64. A sample clocking diagram of a single read SPI operation is shown in Figure 65. The MISO pin goes from tristate to being driven at the beginning of Byte 3. In this example, Byte 0 to Byte 2 contain the addresses and the R/W bit and the subsequent bytes carry the data.

Table 23. Generic SPI Word Format

Byte 0	Byte 1	Byte 2	Byte 3	Byte 4 ¹
0000000, R/W	Register/Memory Address[15:8]	Register/Memory Address[7:0]	Data	Data

¹ Continues to the end of data transmission for the burst mode write.

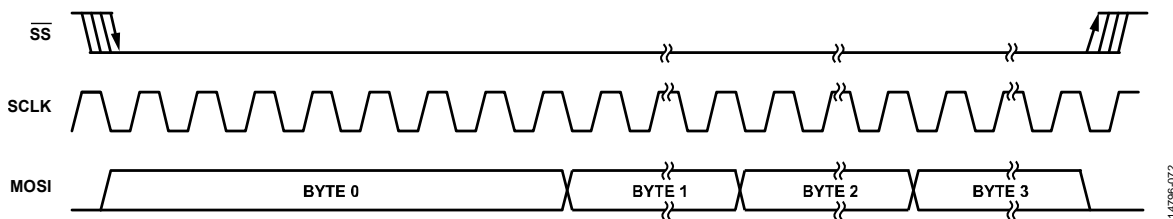

Figure 64. SPI Write to ADAU1777 Clocking (Single Write Mode)

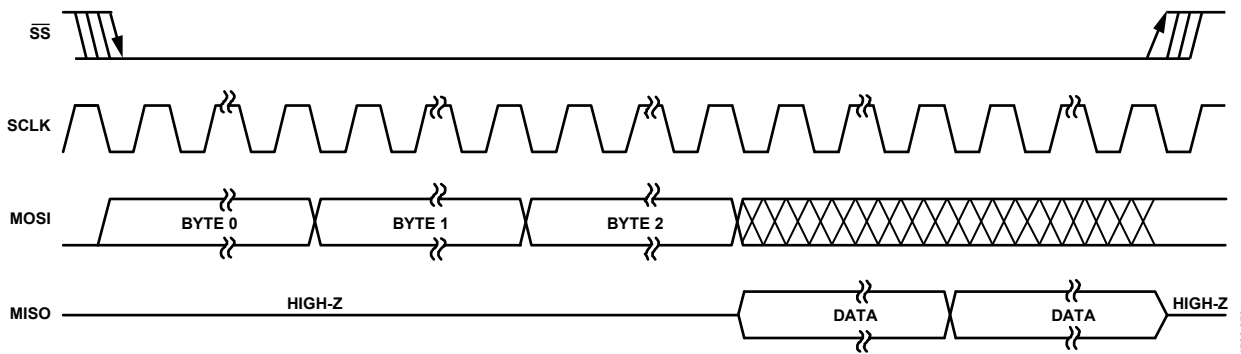

Figure 65. SPI Read from ADAU1777 Clocking (Single Read Mode)

SELF BOOT

The ADAU1777 boots up from an EEPROM over the I²C bus when the SELFBOT pin is set high at power-up and the PD pin is set high. The state of the SELFBOT pin is checked only when the ADAU1777 exits a reset via the PD pin, and when the EEPROM is not used after a self boot is complete. During booting, ensure that a stable DVDD voltage is in the system. The PD pin remains high during the self boot operation. The master SCL clock output from the ADAU1777 is derived from the input clock on XTALI/MCLKIN. A divide by 64 circuit ensures that the SCL output frequency during the self boot operation is never greater than 400 kHz for most input clock frequencies. With the external master clock to the ADAU1777 between 12 MHz and 27 MHz, the SCL frequency ranges from 176 kHz to 422 kHz. If the self boot EEPROM is not rated for operation above 400 kHz, use a master clock that is no faster than 25.6 MHz.

Table 25 shows the list of instructions that are possible during an ADAU1777 self boot. The 0x01 and 0x05 instruction bytes load the register, program, and parameter settings.

EEPROM Size

The self boot circuit is compatible with an EEPROM that has a 2-byte address. For most EEPROM families, a 2-byte address is used on devices that are 32 kB or larger. The EEPROM must be set to Address 0x50. Examples of two compatible EEPROMs include the Atmel® AT24C32D and STMicroelectronics M24C32-F. Table 24 lists the maximum necessary EEPROM size, assuming that there is 100% utilization of the program and parameters (both banks). There is inherently some overhead for instructions to control the self boot procedure.

Table 24. Maximum EEPROM Size

ADAU1777 Memory Blocks	Word Size (Bytes per Word)	Words	Total EEPROM Space Requirement (Bytes)
Program	2	32	64
Bank A Parameters	4	160 (32 × 5)	640
Bank B Parameters	4	160	640
Registers	1	65	65
Total Bytes			2049

Cyclic Redundancy Check (CRC)

An 8-bit CRC validates the content of the EEPROM. This CRC is strong enough to detect single error bursts of up to eight bits in size. The terminate self boot instruction (0x instruction byte) must be followed by a CRC byte. The CRC is generated using all of the EEPROM bytes from Address 0x00 to the last 0x00 instruction byte. The polynomial for the CRC is

$$x^8 + x^2 + x + 1$$

If the CRC is incorrect or if an unrecognized instruction byte is read during self boot, the boot process is immediately stopped and restarted after a 250 ms delay (for a 12.288 MHz input clock). When SigmaStudio is used, the CRC byte is generated automatically when a configuration is downloaded to the EEPROM.

Delay

The delay instruction (0x02 instruction byte) delays by the 16-bit setting × 2048 clock cycles.

Boot Time

The time to self boot the ADAU1777 from an EEPROM can be calculated using the following equation:

$$Boot\ Time = 64 / MCLK\ Frequency \times Total\ Bytes + Wait\ Time$$

The self boot operation starts after 16,568 clock cycles are seen on the XTALI/MCLKIN pin after PD is set high. With a 12.288 MHz clock, this number of cycles corresponds to approximately a 1.35 ms wait time from power-up. This delay ensures that the crystal used for generating the master clock has ramped up to a stable oscillation.

Table 25. EEPROM Self Boot Instructions

Instruction Byte ID	Instruction Byte Description	Following Bytes
0x00	End self boot	CRC
0x01	Write multibyte length minus two bytes, starting at target address	Length (high byte), length (low byte), address (high byte), address (low byte), data (0), data (1), ..., data (length – 3)
0x02	Delays by the 16-bit setting × 2048 clock cycles	Delay (high byte), delay (low byte)
0x03	No operation	None
0x04	Wait for PLL lock	None
0x05	Write single byte to target address	Address (high byte), address (low byte), data

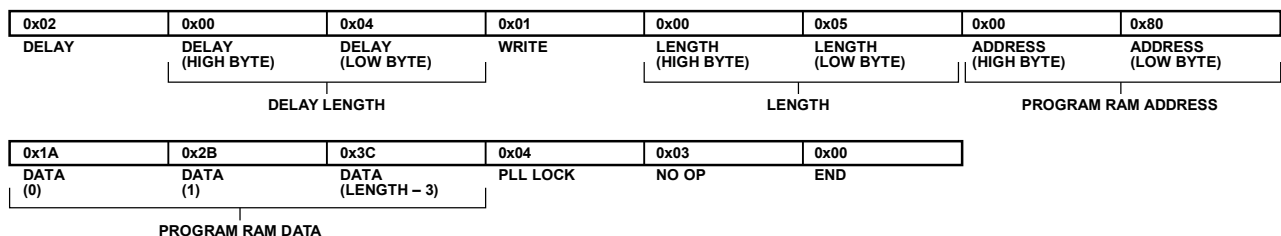

Figure 66. Example Self Boot EEPROM Instructions

MULTIPURPOSE PINS

The ADAU1777 has seven multipurpose (MPx) pins that can be used for serial data input/output, clock outputs, and control in a system without a microcontroller. Each pin can be individually set to either its default or MPx setting. The functions include push-button volume controls, enabling the compressors, parameter bank switching, DSP bypass mode, and muting the outputs.

The function of each of these pins is set in Register 0x38 to Register 0x3E. By default, each pin is configured as an input.

Table 26. Multipurpose Pin Functions

Pin No.	Default Pin Function	Secondary Pin Functions
A2	BCLK	Multipurpose control inputs
A3	MP1 acts as push-button volume up	ADC_SDATA0, PDM output, multipurpose control inputs
A4	MP6 acts as push-button volume down	ADC_SDATA1, CLKOUT, multipurpose control inputs
B2	LRCLK	Multipurpose control inputs
B3	DAC_SDATA	Multipurpose control inputs
B4	DMIC2_3	Multipurpose control inputs
B5	DMIC0_1	Multipurpose control inputs

PUSH-BUTTON VOLUME CONTROLS

The ADC and DAC volume controls can be controlled with two push-buttons: one to increase volume and one to decrease volume. The volume setting can either be changed with a click of the button or can be ramped by holding either button but not both at the same time. The volume settings change when the signal on the pin from the button goes from low to high.

When in push-button mode, the initial volume level is set with the PB_VOL_INIT_VAL bits. By default, MP1 acts as the push-button volume up control and MP6 acts as the push-button volume down control; however, any of the MPx pins can be set to act as the push-button up and push-button down volume controls.

When the ADC and/or DAC volumes are controlled with the push-buttons, the corresponding volume control registers no longer allow control of the volume from the control port. Therefore, writing to these volume control registers has no effect on the codec volume level.

LIMITER COMPRESSION ENABLE

The limiter compression enable function allows a user to enable limiter compression regardless of the signal level. Setting an MPx pin low when this function is enabled causes the limiter to compress the incoming signal by the minimum gain setting. When the MPx pin is released, the limiter resumes normal behavior.

PARAMETER BANK SWITCHING

An MPx pin can be used to switch the active parameter bank between Bank A and Bank B. When one of these settings is selected, Bank A is active when the MPx pin is high and Bank B is active when the MPx pin is low. Set the BANK_SL bits in the CORE_CONTROL register (Address 0x09) to the default value of 0x00 before enabling MPx pin control over bank switching. Simultaneous control of bank switching by both register setting and MPx pin selection is not possible.

The ZERO_STATE bit selects whether the data memory of the codec is set to 0 during a bank switch. If the data is not set to 0 when a new set of filter coefficients is enabled via a bank switch, there may be a pop in the audio as the old data is circulated in the new filters.

MUTE

The MPx pins can be put into a mode to mute the ADCs or DACs. When in this mode, mute is enabled when an MPx pin is set low. The full combination of possible mutes for the ADCs and DACs using the MPx pins are set in Register 0x38 to Register 0x3E.

DSP BYPASS MODE

When DSP bypass mode is enabled, a direct path from the ADC outputs to the DACs is set up to enable bypassing the core processing to listen to environmental sounds. This mode is useful for listening to someone speaking without having to remove the noise canceling headphones. The DSP bypass path is enabled by setting an MPx pin low. Figure 67 shows the DSP bypass path disabled, and Figure 68 shows the DSP bypass path enabled by pressing the push-button switch. The DSP bypass feature works for both analog and digital microphone inputs.

DSP bypass is enabled when a switch connected to an MPx pin that is set to DSP bypass mode is closed and the MPx pin signal

is pulled low. Pressing and holding the switch closed enables the DSP bypass signal path as defined in the TALKTHRU register (Address 0x2A). The DAC volume control setting is switched from the default gain setting to the new TALKTHRU_GAINx register setting (Address 0x2B and Address 0x2C). DSP bypass is enabled only on ADC0 and ADC1. The DSP bypass signal path is from the output of ADCx to the input of the DAC(s).

When DSP bypass is enabled, the current DAC volume setting is ramped down to -95.625 dB and the DSP bypass volume setting is ramped up to avoid pops when switching paths.

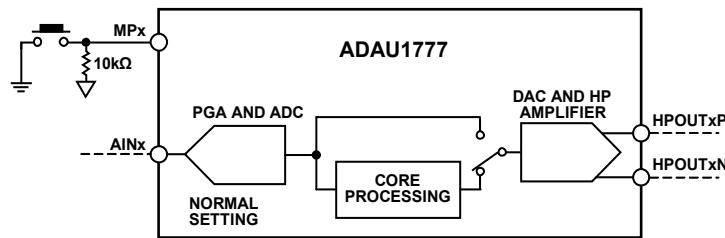

Figure 67. DSP Bypass Path Disabled

14796-075

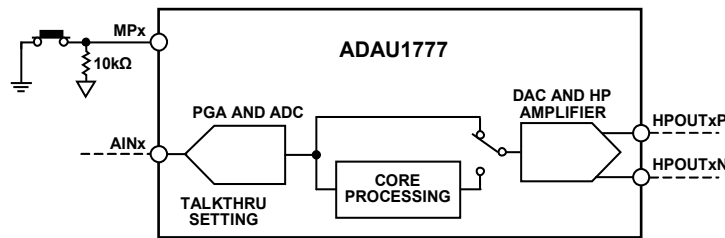

Figure 68. DSP Bypass Path Enabled

14796-076

SERIAL DATA INPUT/OUTPUT PORTS

The serial data input and output ports of the ADAU1777 can be set to accept or transmit data in a 2-channel format or in a 4-channel or 8-channel TDM stream mode to interface to external ADCs, DACs, DSPs, and systems on chip (SOCs). Data is processed in twos complement, MSB first format. The left channel data field always precedes the right channel data field in the 2-channel streams. In 8-channel TDM mode, the data channels are output sequentially, starting with the channel set by the ADC_SDATA0_ST and ADC_SDATA1_ST bits. The serial modes and the position of the data in the frame are set in the serial data port (SAI_0, SAI_1) and serial output control registers (SOUT_SOURCE_x_y, Address 0x13 to Address 0x16).

The serial data clocks do not need to be synchronous with the ADAU1777 master clock input, but the LRCLK and BCLK pins must be synchronous to each other. The LRCLK and BCLK pins both clock the serial input and output ports. The ADAU1777 can be set to be either the master or the slave in a system. Because there is only one set of serial data clocks, the input and output ports must always both be either master or slave.

The serial data control registers allow control of the clock polarity and the data input modes. The valid data formats are I²S, left justified, right justified (24- or 16-bit), PCM, and TDM. In all modes except for the right justified modes, the serial port inputs an arbitrary number of bits up to a limit of 24. Extra bits do not cause an error, but they are truncated internally.

The serial port can operate with an arbitrary number of BCLK transitions in each LRCLK frame. The LRCLK in TDM mode can be input to the ADAU1777 either as a 50% duty cycle clock or as a 1-bit wide pulse. Table 27 lists the modes in which the serial input/output port can function. When using low IOVDD (1.8 V) with a high BCLK rate (12.288 MHz), a sample rate of 192 kHz, or a 8-channel TDM mode operating at a sample rate of 48 kHz,

Table 28. Serial Port Data Format Settings

Format	LRCLK Polarity (LR_POL)	LRCLK Type (LR_MODE)	BCLK Polarity (BCLKEDGE) ¹	MSB Position (SDATA_FMT)
I ² S (See Figure 69)	0	0	0	00
Left Justified (See Figure 70)	1	0	0	01
Right Justified (See Figure 71 and Figure 72)	1	0	0	10 or 11
TDM (See Figure 73 and Figure 74)	1	0 or 1	0	00
PCM/DSP Short Frame Sync (See Figure 75)	1	1	X	00
PCM/DSP Long Frame Sync (See Figure 76)	1	0	X	01

¹ X means don't care.

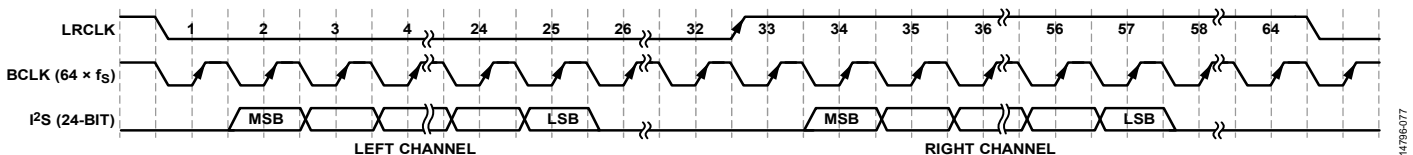

Figure 69. I²S Mode, 16 Bits to 24 Bits per Channel

it is recommended to use the high drive settings on the serial port pins. The high drive strength effectively speeds up the transition times of the waveforms, thereby improving the signal integrity of the clock and data lines. These can be set in the PAD_CONTROL4 register (Address 0x4C).

Table 27. Serial Input/Output Port Master/Slave Mode Capabilities

Serial Data Sample Rate	2-Channel Modes (I ² S, Left Justified, Right Justified)	4-Channel TDM	8-Channel TDM
48 kHz	Yes	Yes	Yes
96 kHz	Yes	Yes	No
192 kHz	Yes	No	No

Table 28 describes the proper serial port settings for standard audio data formats. More information about the settings in Table 28 is in the Serial Port Control 0 register and the Serial Port Control 1 register (Address 0x32 and Address 0x33) descriptions in Table 87 and Table 88, respectively.

TRISTATING UNUSED CHANNELS

Unused outputs can be tristated so that multiple ICs can drive a single TDM line. This function is available only when the serial ports of the ADAU1777 are operating in TDM mode. Set inactive channels in the SOUT_CONTROL0 register (Address 0x34). The tristating of inactive channels is set in the SAI_1 register (Address 0x33), which offers the option of tristating or driving the inactive channel.

In a 32-bit TDM frame with 24-bit data, the eight unused bits are tristated. Inactive channels are also tristated for the full frame.

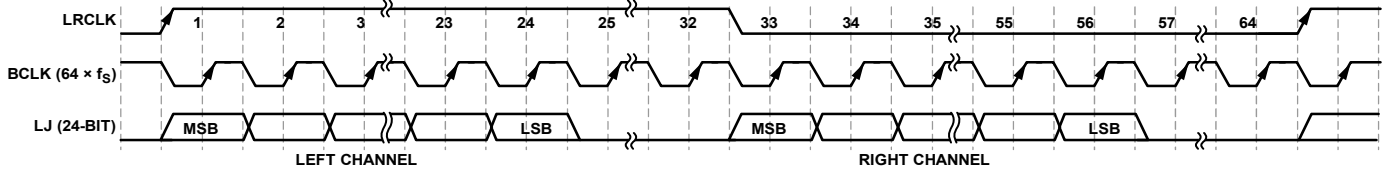

Figure 70. Left Justified (LJ) Mode, 16 Bits to 24 Bits per Channel

14796-078

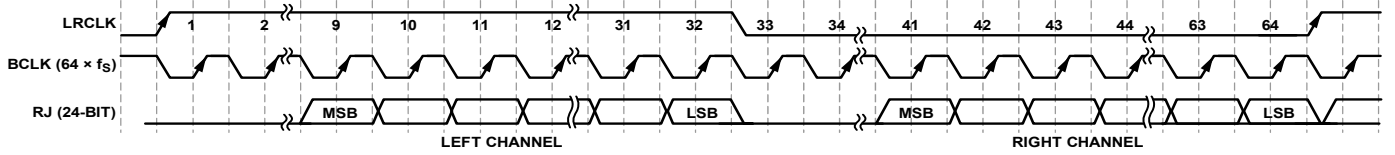

Figure 71. Right Justified (RJ) Mode, 24 Bits per Channel

14796-079

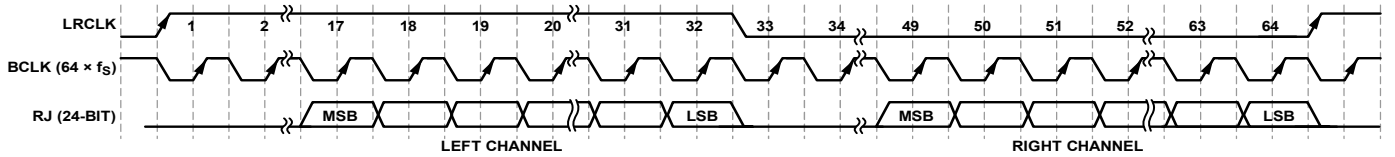

Figure 72. Right Justified (RJ) Mode, 16 Bits per Channel

14796-080

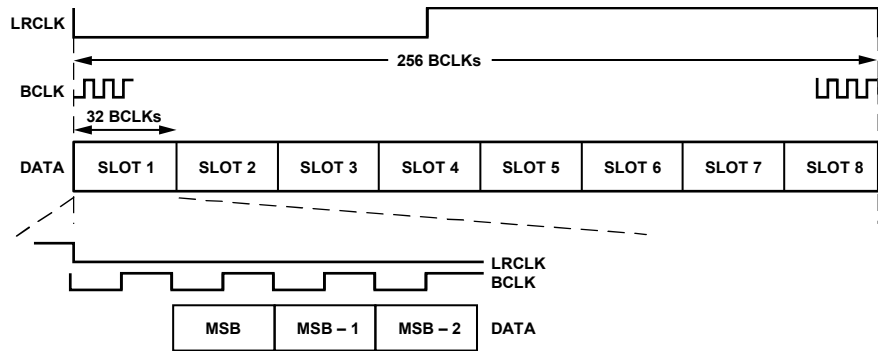

Figure 73. 8-Channel TDM Mode

14796-081

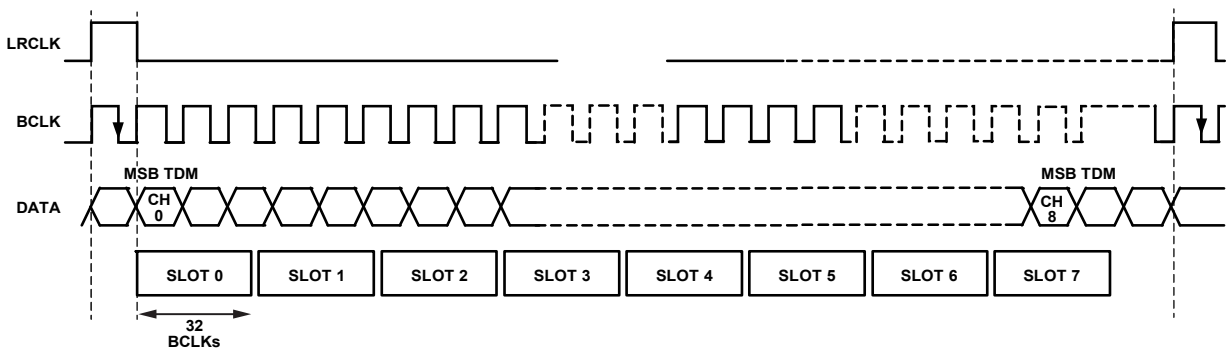

Figure 74. 8-Channel TDM Mode, Pulse LRCLK

14796-082

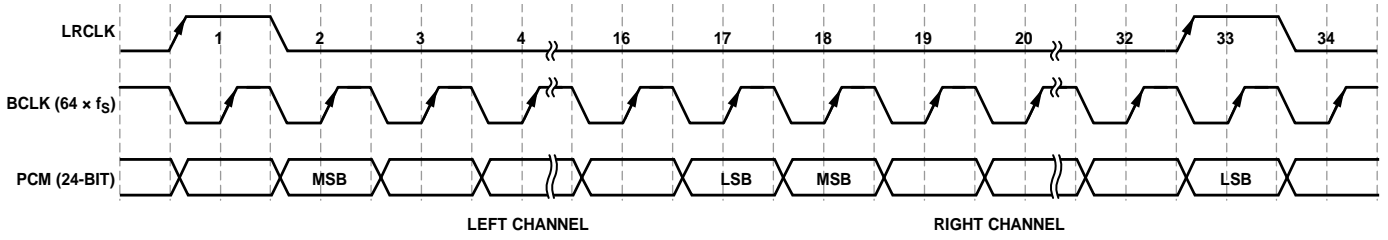

Figure 75. PCM/DSP Mode, 16 Bits per Channel, Short Frame Sync

14796-083

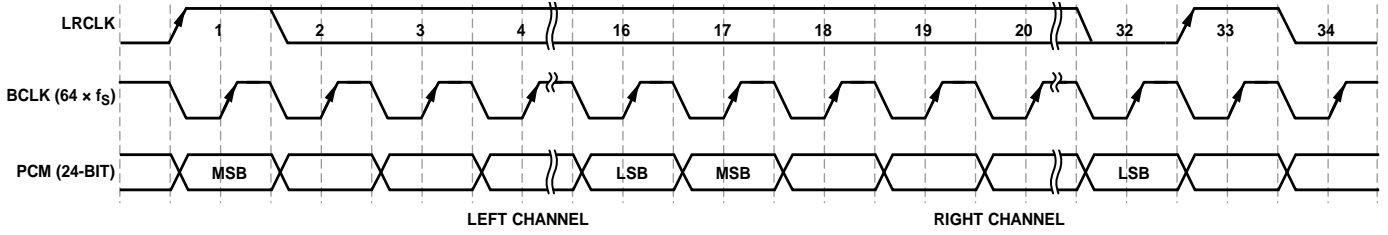

Figure 76. PCM/DSP Mode, 16 Bits per Channel, Long Frame Sync

14796-084

APPLICATIONS INFORMATION

POWER SUPPLY BYPASS CAPACITORS

Bypass each analog and digital power supply pin to its nearest appropriate ground pin with a single 0.1 μF capacitor. The connections to each side of the capacitor must be as short as possible, and the trace must be routed on a single layer with no vias. For maximum effectiveness, locate the capacitor equidistant from the power and ground pins or slightly closer to the power pin if equidistant placement is not possible. Make thermal connections to the ground planes on the far side of the capacitor.

Bypass each supply signal on the board with a single bulk capacitor (10 μF to 47 μF).

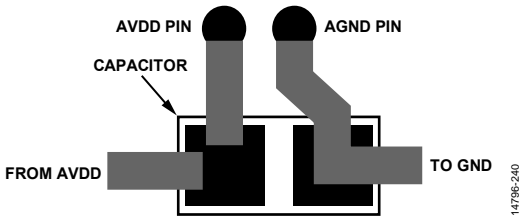

Figure 77. Recommended Example Power Supply Bypass Capacitor Layout

LAYOUT

Pin D1 and Pin F2 are the AVDD supplies for the headphone amplifiers. If the headphone amplifiers are enabled, the PCB trace to these pins must be wider than traces to other pins to increase the current carrying capacity. A wider trace must also be used for the headphone output lines where possible.

GROUNDING

A ground plane must be used in the application layout. Place components in an analog signal path away from digital signals wherever possible.

PCB STACKUP

The example PCB stackup in Figure 78 is a 4-layer design. Four is the minimum layer count. The two inner layers are used as power and ground planes. The outer layers are used as signal layers and are flooded with the ground plane. It is recommended to use several 0.1 μF bypass capacitors to decouple the power and ground plane for EMI concerns. Place these capacitors around the edges of the ground plane.

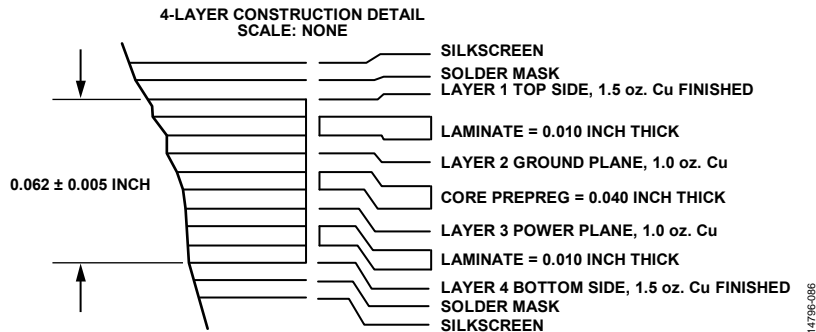

Figure 78. Example PCB Stackup Details

LOW LATENCY REGISTER SETTINGS

The ADAU1777 utilizes the ADAU1772 architecture and incorporates additional register settings for reductions in latency, as shown in Table 29 to Table 35.

Table 29. Core Control Register (Register 0x0009)

Bits	Bit Name	Settings	Description
[4:3]	FAST_SLOW_RATE	00 01 10	These bits select the speed of the slow rate relative to the fast rate. This setting must not be changed while the core is running. The CORE_RUN bit must be set to 0 for this setting to be updated. Slow rate = fast rate. Slow rate = fast rate/4. Slow rate = fast rate/8.
[2:1]	CORE_FS	00 01 10 11	These bits select the core sample rate. Note that the ADAU1777 supports an additional 768 kHz sample rate for reduced latency. This setting must not be changed while the core is running. The CORE_RUN bit must be set to 0 for this setting to be updated. Reserved. 96 kHz. 192 kHz. 768 kHz.

Table 30. Sleep on Program Address Count Register (Register 0x000A)

Bits	Bit Name	Settings	Description
[4:0]	SLEEP	00000 00001 00010 00011 11111	The sleep on program address count register controls which registers are executed. Subtract 2 from the SLEEP bit setting to indicate the number of addresses that are affected. For example, if SLEEP = 7, only instructions at Address 0x0000 to Address 0x0005 are executed. This setting must not be changed while the core is running. The CORE_RUN bit must be set to 0 for this setting to be updated. No sleep, all instructions are executed. Reserved. Sleep on 0. Sleep on 1. Sleep on 29.

Table 31. ADC0/ADC1 Control 0 Register (Register 0x001B)

Bits	Bit Name	Settings	Description
5	ADC_0_1_SINC	0 1	This bit selects either a third-order or fourth-order sinc filter. This setting must not be changed while the core is running. The CORE_RUN bit must be set to 0 for this setting to be updated. Fourth-order sinc. Third-order sinc.
[1:0]	ADC_0_1_FS	00 01 10 11	These bits set the ADC sample rate. The ADAU1777 supports the option of 768 kHz as well. Note that the frequency selected must match the CORE_FS selected via Bits[2:1] of Register 0x0009. 96 kHz. 192 kHz. 768 kHz. Reserved.

Table 32. ADC2/ADC31 Control 0 Register (Register 0x001C)

Bits	Bit Name	Settings	Description
5	ADC_2_3_SINC	0 1	This bit selects either a third-order or fourth-order sinc filter. This setting must not be changed while the core is running. The CORE_RUN bit must be set to 0 for this setting to be updated. Fourth-order sinc. Third-order sinc.
[1:0]	ADC_2_3_FS	00 01 10 11	These bits set the ADC sample rate. The ADAU1777 supports the option of 768 kHz as well. 96 kHz. 192 kHz. 768 kHz. Reserved.

Table 33. Fast Rate Control Register (Register 0x004E)

Bits	Bit Name	Settings	Description
[2:0]	RATE_DIV	000 001 010 011 100 101	Bits[2:0] set the fast rate division factor. This factor is used to divide the internal master clock (6.144 MHz) when CORE_FS = 11. This setting must not be changed while the core is running. CORE_RUN must be set to 0 for this setting to be updated. The settings for RATE_DIV follow: Divide by 8 (768 kHz). Divide by 9 (683 kHz). Divide by 10 (614 kHz). Divide by 12 (512 kHz). Divide by 14 (439 kHz). Divide by 16 (384 kHz).

Table 34. DAC Interpolation Control Register (Register 0x004F)

Bits	Bit Name	Settings	Description
[7:6]	DAC_RATE	00 01 10 11	These bits set the DAC_RATE value, which sets the sample rate for the DAC only. Core f_s . Core $f_s/4$. Core $f_s/8$. Reserved.
[5:3]	DAC_INTP	000 001 010 011 100 101 110	These bits set the DAC_INTP value, which sets the interpolation mode for the DAC. Both DAC0 and DAC1 set to compensated interpolation. DAC0 set to zero-order hold (ZOH), DAC1 set to compensated interpolation. DAC0 set to compensated interpolation, DAC1 set to ZOH. Both DAC0 and DAC1 set to ZOH. DAC0 set to linear interpolation, DAC1 set to compensated interpolation. DAC0 set to compensated interpolation, DAC1 set to linear interpolation. Both DAC0 and DAC1 set to linear interpolation.

Table 35. Volume Control Bypass Register (Register 0x0054)

Bits	Bit Name	Settings	Description
5	DAC1VOL_BY	0 1	DAC1 volume control bypass. Volume control enabled. Bypassed.
4	DAC0VOL_BY	0 1	DAC0 volume control bypass. Volume control enabled. Bypassed.
3	ADC3VOL_BY	0 1	ADC3 volume control bypass. Volume control enabled. Bypassed.
2	ADC2VOL_BY	0 1	ADC2 volume control bypass. Volume control enabled. Bypassed.
1	ADC1VOL_BY	0 1	ADC1 volume control bypass. Volume control enabled. Bypassed.
0	ADC0VOL_BY	0 1	ADC0 volume control bypass. Volume control enabled. Bypassed.

REGISTER SUMMARY

Table 36. Register Summary

Reg.	Name	Bits	Bit 7	Bit 6	Bit 5	Bit 4	Bit 3	Bit 2	Bit 1	Bit 0	Reset	RW	
0x00	CLK_CONTROL	[7:0]	PLL_EN	RESERVED	SPK_FLT_DIS	XTAL_DIS	CLKSRC	CC_CDIV	CC_MDIV	COREN	0x00	R/W	
0x01	PLL_CTRL0	[7:0]	M_MSB								0x00	R/W	
0x02	PLL_CTRL1	[7:0]	M_LSB								0x00	R/W	
0x03	PLL_CTRL2	[7:0]	N_MSB								0x00	R/W	
0x04	PLL_CTRL3	[7:0]	N_LSB								0x00	R/W	
0x05	PLL_CTRL4	[7:0]	RESERVED	R				X		PLL_TYPE	0x00	R/W	
0x06	PLL_CTRL5	[7:0]	RESERVED							LOCK	0x00	R/W	
0x07	CLKOUT_SEL	[7:0]	RESERVED					CLKOUT_FREQ			0x00	R/W	
0x08	REGULATOR	[7:0]	RESERVED					REG_PD	REGV			0x00	R/W
0x09	CORE_CONTROL	[7:0]	ZERO_STATE	BANK_SL		FAST_SLOW_RATE		CORE_FS		CORE_RUN	0x04	R/W	
0x0A	SLEEP_INST	[7:0]	RESERVED				SLEEP				0x00	R/W	
0x0B	CORE_ENABLE	[7:0]	RESERVED						LIM_EN	DSP_CLK_EN	0x03	R/W	
0x0C	DBREG0	[7:0]	DBVAL0								0x00	R	
0x0D	DBREG1	[7:0]	DBVAL1								0x00	R	
0x0E	DBREG2	[7:0]	DBVAL2								0x00	R	
0x0F	CORE_IN_MUX_0_1	[7:0]	CORE_IN_MUX_SEL_1				CORE_IN_MUX_SEL_0				0x10	R/W	
0x10	CORE_IN_MUX_2_3	[7:0]	CORE_IN_MUX_SEL_3				CORE_IN_MUX_SEL_2				0x32	R/W	
0x11	DAC_SOURCE_0_1	[7:0]	DAC_SOURCE1				DAC_SOURCE0				0x10	R/W	
0x12	PDM_SOURCE_0_1	[7:0]	PDM_SOURCE1				PDM_SOURCE0				0x32	R/W	
0x13	SOUT_SOURCE_0_1	[7:0]	SOUT_SOURCE1				SOUT_SOURCE0				0x54	R/W	
0x14	SOUT_SOURCE_2_3	[7:0]	SOUT_SOURCE3				SOUT_SOURCE2				0x76	R/W	
0x15	SOUT_SOURCE_4_5	[7:0]	SOUT_SOURCE5				SOUT_SOURCE4				0x54	R/W	
0x16	SOUT_SOURCE_6_7	[7:0]	SOUT_SOURCE7				SOUT_SOURCE6				0x76	R/W	
0x17	ADC_SDATA_CH	[7:0]	RESERVED					ADC_SDATA1_ST	ADC_SDATA0_ST			0x04	R/W
0x18	ASRC_SOURCE_0_1	[7:0]	ASRC_OUT_SOURCE1					ASRC_OUT_SOURCE0				0x10	R/W
0x19	ASRC_SOURCE_2_3	[7:0]	ASRC_OUT_SOURCE3					ASRC_OUT_SOURCE2				0x32	R/W
0x1A	ASRC_MODE	[7:0]	RESERVED					ASRC_IN_CH		ASRC_OUT_EN	ASRC_IN_EN	0x00	R/W
0x1B	ADC_CONTROL0	[7:0]	RESERVED		ADC_0_1_SINC	ADC1_MUTE	ADC0_MUTE	RESERVED		ADC_0_1_FS	0x19	R/W	
0x1C	ADC_CONTROL1	[7:0]	RESERVED		ADC_2_3_SINC	ADC3_MUTE	ADC2_MUTE	RESERVED		ADC_2_3_FS	0x19	R/W	
0x1D	ADC_CONTROL2	[7:0]	RESERVED	HP_0_1_EN		DMIC_POLO	DMIC_SW0	DCM_0_1	ADC_1_EN	ADC_0_EN	0x00	R/W	
0x1E	ADC_CONTROL3	[7:0]	RESERVED	HP_2_3_EN		DMIC_POL1	DMIC_SW1	DCM_2_3	ADC_3_EN	ADC_2_EN	0x00	R/W	
0x1F	ADC0_VOLUME	[7:0]	ADC_0_VOL								0x00	R/W	
0x20	ADC1_VOLUME	[7:0]	ADC_1_VOL								0x00	R/W	
0x21	ADC2_VOLUME	[7:0]	ADC_2_VOL								0x00	R/W	
0x22	ADC3_VOLUME	[7:0]	ADC_3_VOL								0x00	R/W	

Reg.	Name	Bits	Bit 7	Bit 6	Bit 5	Bit 4	Bit 3	Bit 2	Bit 1	Bit 0	Reset	RW	
0x23	PGA_CONTROL_0	[7:0]	PGA_EN0	PGA_MUTE0	PGA_GAIN0						0x40	R/W	
0x24	PGA_CONTROL_1	[7:0]	PGA_EN1	PGA_MUTE1	PGA_GAIN1						0x40	R/W	
0x25	PGA_CONTROL_2	[7:0]	PGA_EN2	PGA_MUTE2	PGA_GAIN2						0x40	R/W	
0x26	PGA_CONTROL_3	[7:0]	PGA_EN3	PGA_MUTE3	PGA_GAIN3						0x40	R/W	
0x27	PGA_STEP_CONTROL	[7:0]	RESERVED		SLEW_RATE		SLEW_PD3	SLEW_PD2	SLEW_PD1	SLEW_PD0	0x00	R/W	
0x28	PGA_10DB_BOOST	[7:0]	RESERVED				PGA_3_BOOST	PGA_2_BOOST	PGA_1_BOOST	PGA_0_BOOST	0x00	R/W	
0x29	POP_SUPPRESS	[7:0]	RESERVED		HP_POP_DIS1	HP_POP_DIS0	PGA_POP_DIS3	PGA_POP_DIS2	PGA_POP_DIS1	PGA_POP_DIS0	0x3F	R/W	
0x2A	TALKTHRU	[7:0]	RESERVED						TALKTHRU_PATH		0x00	R/W	
0x2B	TALKTHRU_GAIN0	[7:0]	TALKTHRU_GAIN0_VAL									0x00	R/W
0x2C	TALKTHRU_GAIN1	[7:0]	TALKTHRU_GAIN1_VAL									0x00	R/W
0x2D	MIC_BIAS	[7:0]	RESERVED		MIC_EN1	MIC_EN0	RESERVED	RESERVED	MIC_GAIN1	MIC_GAIN0	0x00	R/W	
0x2E	DAC_CONTROL1	[7:0]	RESERVED		DAC_POL	DAC1_MUTE	DAC0_MUTE	RESERVED	DAC1_EN	DAC0_EN	0x18	R/W	
0x2F	DAC0_VOLUME	[7:0]	DAC_0_VOL									0x00	R/W
0x30	DAC1_VOLUME	[7:0]	DAC_1_VOL									0x00	R/W
0x31	OP_STAGE_MUTES	[7:0]	RESERVED				HP_MUTE_R		HP_MUTE_L		0x0F	R/W	
0x32	SAI_0	[7:0]	SDATA_FMT		SAI		SER_PORT_FS				0x00	R/W	
0x33	SAI_1	[7:0]	TDM_TS	BCLK_TDMC	LR_MODE	LR_POL	SAI_MSB	BCLKRATE	BCLKEDGE	SAI_MS	0x00	R/W	
0x34	SOUT_CONTROLO	[7:0]	TDM7_DIS	TDM6_DIS	TDM5_DIS	TDM4_DIS	TDM3_DIS	TDM2_DIS	TDM1_DIS	TDM0_DIS	0x00	R/W	
0x36	PDM_OUT	[7:0]	RESERVED			PDM_CTRL	PDM_CH		PDM_EN		0x00	R/W	
0x37	PDM_PATTERN	[7:0]	PATTERN									0x00	R/W
0x38	MODE_MP0	[7:0]	RESERVED				MODE_MP0_VAL				0x00	R/W	
0x39	MODE_MP1	[7:0]	RESERVED				MODE_MP1_VAL				0x10	R/W	
0x3A	MODE_MP2	[7:0]	RESERVED				MODE_MP2_VAL				0x00	R/W	
0x3B	MODE_MP3	[7:0]	RESERVED				MODE_MP3_VAL				0x00	R/W	
0x3C	MODE_MP4	[7:0]	RESERVED				MODE_MP4_VAL				0x00	R/W	
0x3D	MODE_MP5	[7:0]	RESERVED				MODE_MP5_VAL				0x00	R/W	
0x3E	MODE_MP6	[7:0]	RESERVED				MODE_MP6_VAL				0x11	R/W	
0x3F	PB_VOL_SET	[7:0]	PB_VOL_INIT_VAL					HOLD				0x00	R/W
0x40	PB_VOL_CONV	[7:0]	GAINSTEP		RAMPSPEED			PB_VOL_CONV_VAL				0x87	R/W
0x41	DEBOUNCE_MODE	[7:0]	RESERVED						DEBOUNCE			0x05	R/W
0x43	OP_STAGE_CTRL	[7:0]	RESERVED		HP_EN_R	HP_EN_L	HP_PDN_R		HP_PDN_L		0x0F	R/W	
0x44	DECIM_PWR_MODES	[7:0]	DEC_3_EN	DEC_2_EN	DEC_1_EN	DEC_0_EN	SINC_3_EN	SINC_2_EN	SINC_1_EN	SINC_0_EN	0x00	R/W	
0x45	INTERP_PWR_MODES	[7:0]	RESERVED				MOD_1_EN	MOD_0_EN	INT_1_EN	INT_0_EN	0x00	R/W	
0x46	BIAS_CONTROLO	[7:0]	HP_IBIAS		AFE_IBIAS01		ADC_IBIAS23		ADC_IBIAS01		0x00	R/W	
0x47	BIAS_CONTROL1	[7:0]	RESERVED	CBIAS_DIS	AFE_IBIAS23		MIC_IBIAS		DAC_IBIAS		0x00	R/W	
0x48	PAD_CONTROLO	[7:0]	RESERVED	DMIC2_3_PU	DMIC0_1_PU	LRCLK_PU	BCLK_PU	ADC_SDATA1_PU	ADC_SDATA0_PU	DAC_SDATA_PU	0x7F	R/W	
0x49	PAD_CONTROL1	[7:0]	RESERVED			SELFBOT_PU	SCL_PU	SDA_PU	ADDR1_PU	ADDR0_PU	0x1F	R/W	

Reg.	Name	Bits	Bit 7	Bit 6	Bit 5	Bit 4	Bit 3	Bit 2	Bit 1	Bit 0	Reset	RW
0x4A	PAD_CONTROL2	[7:0]	RESERVED	DMIC2_3_PD	DMIC0_1_PD	LRCLK_PD	BCLK_PD	ADC_SDATA1_PD	ADC_SDATA0_PD	DAC_SDATA_PD	0x00	R/W
0x4B	PAD_CONTROL3	[7:0]	RESERVED			SELFBOT_PD	SCL_PD	SDA_PD	ADDR1_PD	ADDR0_PD	0x00	R/W
0x4C	PAD_CONTROL4	[7:0]	RESERVED	RESERVED	RESERVED	LRCLK_DRV	BCLK_DRV	ADC_SDATA1_DRV	ADC_SDATA0_DRV	RESERVED	0x00	R/W
0x4D	PAD_CONTROL5	[7:0]	RESERVED			RESERVED	SCL_DRV	SDA_DRV	RESERVED	RESERVED	0x00	R/W
0x4E	FAST_RATE	[7:0]	RESERVED					RATE_DIV			0x00	R/W
0x4F	DAC_CONTROL0	[7:0]	DAC_RATE		DAC_INTP			RESERVED			0x00	R/W
0x54	VOL_BYPASS	[7:0]	RESERVED		DAC1VOL_BY	DAC0VOL_BY	ADC3VOL_BY	ADC2VOL_BY	ADC1VOL_BY	ADC0VOL_BY	0x00	R/W

REGISTER DETAILS

CLOCK CONTROL REGISTER

Address: 0x00, Reset: 0x00, Name: CLK_CONTROL

This register enables the internal clocks.

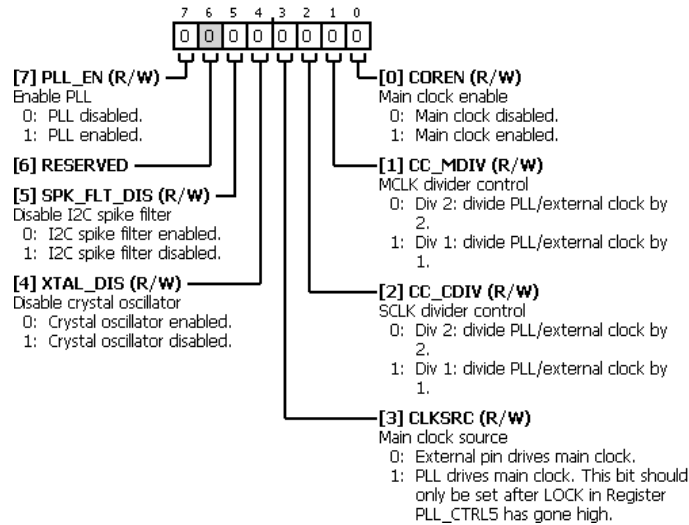

Table 37. Bit Descriptions for CLK_CONTROL

Bits	Bit Name	Settings	Description	Reset	Access
7	PLL_EN	0 1	Enable PLL. When this bit is set to 0, the PLL is powered down and the PLL output clock is disabled. Do not enable the PLL until after all the PLL control settings (Register PLL_CTRL0 to Register PLL_CTRL5) are set. The PLL clock output is active when both PLL_EN = 1 and COREN = 1. PLL disabled. PLL enabled.	0x0	R/W
6	RESERVED		Reserved.	0x0	R/W
5	SPK_FLT_DIS	0 1	Disable I ² C spike filter. By default, the SDA and SCL inputs have a 50 ns spike suppression filter. When the control interface is in SPI mode, this filter is disabled regardless of this setting. I ² C spike filter enabled. I ² C spike filter disabled.	0x0	R/W
4	XTAL_DIS	0 1	Disable crystal oscillator. Crystal oscillator enabled. Crystal oscillator disabled.	0x0	R/W
3	CLKSRC	0 1	Main clock source. External pin drives main clock. PLL drives main clock. This bit must only be set after LOCK in Register PLL_CTRL5 has gone high.	0x0	R/W
2	CC_CDIV	0 1	SCLK divider control. The core clock (SCLK) is used only by the core. It must run at 12.288 MHz. Div 2: divide PLL/external clock by 2. Div 1: divide PLL/external clock by 1.	0x0	R/W

Bits	Bit Name	Settings	Description	Reset	Access
1	CC_MDIV	0 1	MCLK divider control. The internal master clock (MCLK) of the IC is used by all digital logic except the core. It must run at 12.288 MHz. Div 2: divide PLL/external clock by 2. Div 1: divide PLL/external clock by 1.	0x0	R/W
0	COREN	0 1	Main clock enable. When COREN = 0, it is only possible to write to this register and the PLL control registers (PLL_CTRL0 to PLL_CTRL5). This control also enables the PLL clock. If using the PLL, do not set COREN = 1 until LOCK in Register PLL_CTRL5 is 1. Note that, after COREN is enabled, writing to the parameters is disabled until setting DSP_CLK_EN in the CORE_ENABLE register. Main clock disabled. Main clock enabled.	0x0	R/W

PLL DENOMINATOR MSB REGISTER

Address: 0x01, Reset: 0x00, Name: PLL_CTRL0

Only write to this register when PLL_EN = 0 in Register CLK_CONTROL.

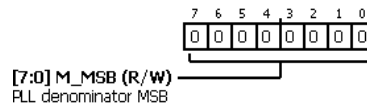

Table 38. Bit Descriptions for PLL_CTRL0

Bits	Bit Name	Settings	Description	Reset	Access
[7:0]	M_MSB		PLL denominator MSB.	0x0	R/W

PLL DENOMINATOR LSB REGISTER

Address: 0x02, Reset: 0x00, Name: PLL_CTRL1

Only write to this register when PLL_EN = 0 in Register CLK_CONTROL.

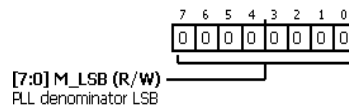

Table 39. Bit Descriptions for PLL_CTRL1

Bits	Bit Name	Settings	Description	Reset	Access
[7:0]	M_LSB		PLL denominator LSB.	0x0	R/W

PLL NUMERATOR MSB REGISTER

Address: 0x03, Reset: 0x00, Name: PLL_CTRL2

Only write to this register when PLL_EN = 0 in Register CLK_CONTROL.

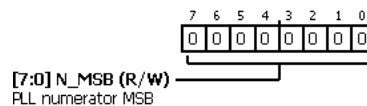

Table 40. Bit Descriptions for PLL_CTRL2

Bits	Bit Name	Settings	Description	Reset	Access
[7:0]	N_MSB		PLL numerator MSB.	0x0	R/W

PLL NUMERATOR LSB REGISTER

Address: 0x04, Reset: 0x00, Name: PLL_CTRL3

Only write to this register when PLL_EN = 0 in Register CLK_CONTROL.

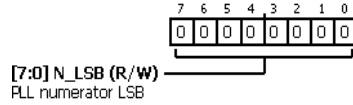

Table 41. Bit Descriptions for PLL_CTRL3

Bits	Bit Name	Settings	Description	Reset	Access
[7:0]	N_LSB		PLL numerator LSB.	0x0	R/W

PLL INTEGER SETTING REGISTER

Address: 0x05, Reset: 0x00, Name: PLL_CTRL4

Only write to this register when PLL_EN = 0 in Register CLK_CONTROL.

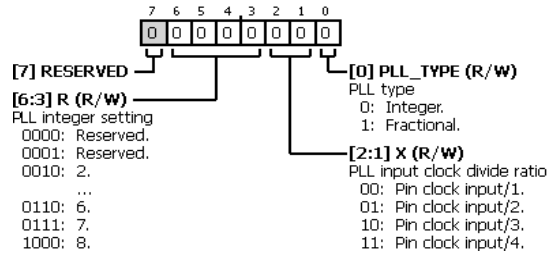

Table 42. Bit Descriptions for PLL_CTRL4

Bits	Bit Name	Settings	Description	Reset	Access
7	RESERVED		Reserved.	0x0	R/W
[6:3]	R	0000 0001 0010 0011 0100 0101 0110 0111 1000	PLL integer setting. Reserved. Reserved. 2. 3. 4. 5. 6. 7. 8.	0x0	R/W
[2:1]	X	00 01 10 11	PLL input clock divide ratio. Pin clock input/1. Pin clock input/2. Pin clock input/3. Pin clock input/4.	0x0	R/W
0	PLL_TYPE	0 1	PLL type. Integer. Fractional.	0x0	R/W

PLL LOCK FLAG REGISTER

Address: 0x06, Reset: 0x00, Name: PLL_CTRL5

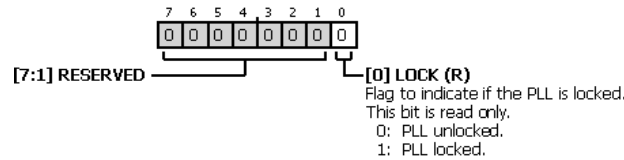

Table 43. Bit Descriptions for PLL_CTRL5

Bits	Bit Name	Settings	Description	Reset	Access
[7:1]	RESERVED		Reserved.	0x0	R/W
0	LOCK	0 1	Flag to indicate if the PLL is locked. This bit is read only. PLL unlocked. PLL locked.	0x0	R

CLKOUT SETTING SELECTION REGISTER

Address: 0x07, Reset: 0x00, Name: CLKOUT_SEL

When the ADC_SDATA1/CLKOUT/MP6 pin is set to clock output mode, the frequency of the output clock is set in this register. CLKOUT can be used to provide a master clock to another IC, the clock for digital microphones, or as the clock for the PDM output stream. The 12 MHz/24 MHz setting is used when clocking another IC, 3 MHz/6 MHz is used for PDMOUT, and 1.5 MHz/3 MHz is used when clocking digital microphones. The CLKOUT frequency is derived from the master clock frequency, which is assumed to (and always must) be 12.288 MHz. The 12.288 MHz and 24.576 MHz output modes are not functional if PDM is enabled (Register PDM_OUT, Bits[1:0]).

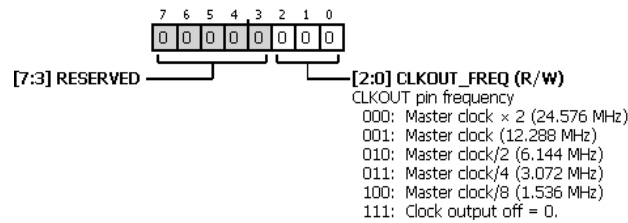

Table 44. Bit Descriptions for CLKOUT_SEL

Bits	Bit Name	Settings	Description	Reset	Access
[7:3]	RESERVED		Reserved.	0x0	R/W
[2:0]	CLKOUT_FREQ	000 001 010 011 100 111	CLKOUT pin frequency. Master clock × 2 (24.576 MHz). Master clock (12.288 MHz). Master clock/2 (6.144 MHz). Master clock/4 (3.072 MHz). Master clock/8 (1.536 MHz). Clock output off = 0.	0x0	R/W

REGULATOR CONTROL REGISTER

Address: 0x08, Reset: 0x00, Name: REGULATOR

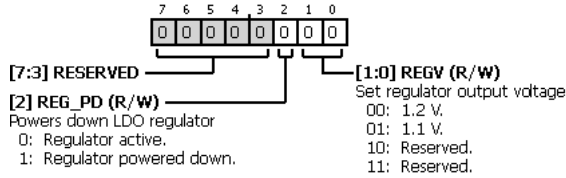

Table 45. Bit Descriptions for REGULATOR

Bits	Bit Name	Settings	Description	Reset	Access
[7:3]	RESERVED		Reserved.	0x0	R/W
2	REG_PD	0 1	Powers down LDO regulator. Regulator active. Regulator powered down.	0x0	R/W
[1:0]	REGV	00 01 10 11	Set regulator output voltage. 1.2 V. 1.1 V. Reserved. Reserved.	0x0	R/W

CORE CONTROL REGISTER

Address: 0x09, Reset: 0x04, Name: CORE_CONTROL

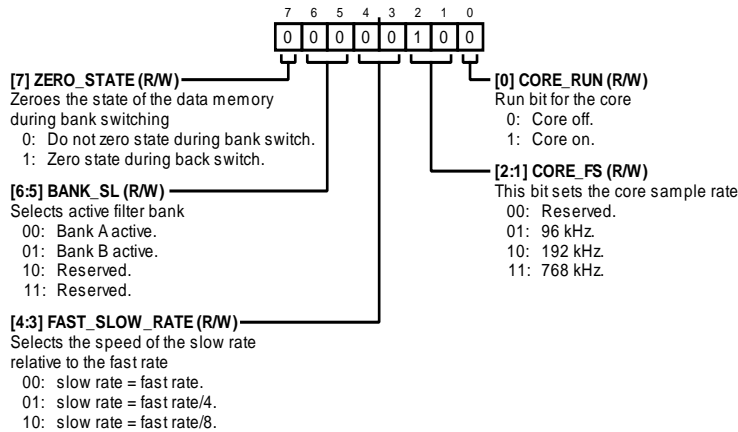

Table 46. Bit Descriptions for CORE_CONTROL

Bits	Bit Name	Settings	Description	Reset	Access
7	ZERO_STATE	0 1	Zeroes the state of the data memory during bank switching. When switching active parameter banks between two settings, zeroing the state of the bank prevents the new filter settings from being active on old data that is recirculating in the filters. Zeroing the state may prevent filter instability or unwanted noises upon bank switching. Do not zero state during bank switch. Zero state during back switch.	0x0	R/W

Bits	Bit Name	Settings	Description	Reset	Access
[6:5]	BANK_SL	00 01 10 11	Selects active filter bank. Bank A active. Bank B active. Reserved. Reserved.	0x0	R/W
[4:3]	FAST_SLOW_RATE	00 01 10	Selects the speed of the slow rate relative to the fast rate. Do not change this setting while the core is running. CORE_RUN must be set to 0 for this setting to be updated. Slow rate = fast rate. Slow rate = fast rate/4. Slow rate = fast rate/8.	0x0	R/W
[2:1]	CORE_FS	00 01 10 11	This bit sets the core sample rate. Do not change this setting while the core is running. CORE_RUN must be set to 0 for this setting to be updated. Reserved. 96 kHz. 192 kHz. 768 kHz. When this mode is set, the fast rate of the core is set in Bits RATE_DIV in the fast rate control register.	0x2	R/W
0	CORE_RUN	0 1	Run bit for the core. Enable this bit only when the program and parameters are loaded and the sample rate settings are set. CORE_RUN starts and stops the core at the beginning of the program. Core off. Core on.	0x0	R/W

SLEEP ON PROGRAM ADDRESS COUNT REGISTER

Address: 0x0A, Reset: 0x00, Name: SLEEP_INST

The SLEEP bits control which registers are sleeping. For example, if SLEEP = 7, only instructions at Address 0x00 to Address 0x05 are executed. SLEEP = 0 disables sleeping.

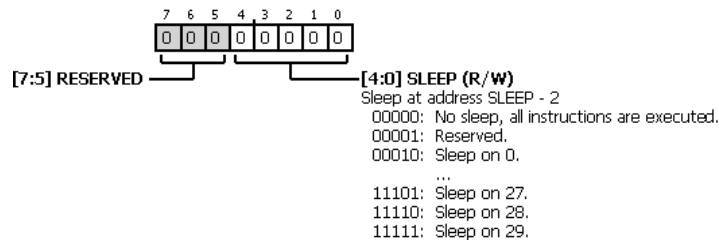

Table 47. Bit Descriptions for SLEEP_INST

Bits	Bit Name	Settings	Description	Reset	Access
[7:5]	RESERVED		Reserved.	0x0	R/W
[4:0]	SLEEP		<p>Sleep at Address SLEEP – 2. These bits control which registers are sleeping. Subtracting 2 from the SLEEP setting indicates the number of addresses that are affected. For example, if SLEEP = 7, only instructions at Address 0x00 to Address 0x05 are executed. Do not change this setting while the core is running. CORE_RUN must be set to 0 for this setting to be updated.</p> <p>00000 No sleep, all instructions are executed.</p> <p>00001 Reserved.</p> <p>00010 Sleep on 0 (0x00).</p> <p>00011 Sleep on 1 (0x01).</p> <p>00100 Sleep on 2 (0x02).</p> <p>00101 Sleep on 3 (0x03).</p> <p>00110 Sleep on 4 (0x04).</p> <p>00111 Sleep on 5 (0x05).</p> <p>01000 Sleep on 6 (0x06).</p> <p>01001 Sleep on 7 (0x07).</p> <p>01010 Sleep on 8 (0x08).</p> <p>01011 Sleep on 9 (0x09).</p> <p>01100 Sleep on 10 (0x0A).</p> <p>01101 Sleep on 11 (0x0B).</p> <p>01110 Sleep on 12 (0x0C).</p> <p>01111 Sleep on 13 (0x0D).</p> <p>10000 Sleep on 14 (0x0E).</p> <p>10001 Sleep on 15 (0x0F).</p> <p>10010 Sleep on 16 (0x10).</p> <p>10011 Sleep on 17 (0x11).</p> <p>10100 Sleep on 18 (0x12).</p> <p>10101 Sleep on 19 (0x13).</p> <p>10110 Sleep on 20 (0x14).</p> <p>10111 Sleep on 21 (0x15).</p> <p>11000 Sleep on 22 (0x16).</p> <p>11001 Sleep on 23 (0x17).</p> <p>11010 Sleep on 24 (0x18).</p> <p>11011 Sleep on 25 (0x19).</p> <p>11100 Sleep on 26 (0x1A).</p> <p>11101 Sleep on 27 (0x1B).</p> <p>11110 Sleep on 28 (0x1C).</p> <p>11111 Sleep on 29 (0x1D).</p>	0x0	R/W

FILTER ENGINE AND LIMITER CONTROL REGISTER

Address: 0x0B, Reset: 0x03, Name: CORE_ENABLE

Disabling the limiter only disables the attack operation. The decay operation is always active; therefore, a limiter can be safely disabled while the decay operation performs gain adjustments.

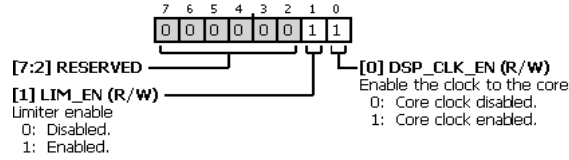

Table 48. Bit Descriptions for CORE_ENABLE

Bits	Bit Name	Settings	Description	Reset	Access
[7:2]	RESERVED		Reserved.	0x0	R/W
1	LIM_EN	0 1	Limiter enable. When the limiter function is disabled, a fixed maximum gain setting is applied to instructions using the limiters. 0 Disabled. 1 Enabled.	0x1	R/W
0	DSP_CLK_EN	0 1	Enable the clock to the core. This bit directly controls the clock to the core. Set this bit to 0 when the chip is used in a codec only configuration, in which the core is not used. Writing to any of the biquad coefficient registers (Parameter Memory Address 0x0E0 to Parameter Memory Address 0x2BF) is blocked until this bit is 1. Do not use this bit to start or stop the core while it is running, because it immediately starts or stops the core clock and does not allow the program to finish. Instead, use CORE_RUN in the CORE_CONTROL register to start or stop the core. 0 Core clock disabled. 1 Core clock enabled.	0x1	R/W

DB VALUE REGISTER 0 READ

Address: 0x0C, Reset: 0x00, Name: DBREG0

The core can write data to this register, and the data is automatically converted to a level in dB. The most common use for this register is to determine the rms value of a signal by taking the absolute value, and then performing low-pass filtering and moving the result to the DBREG0 register.

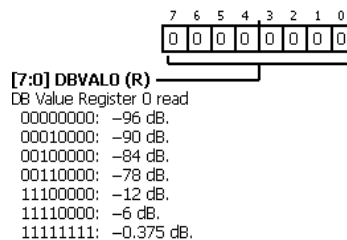

Table 49. Bit Descriptions for DBREG0

Bits	Bit Name	Settings	Description	Reset	Access
[7:0]	DBVAL0	00000000 00010000 00100000 00110000 11100000 11110000 11111111	DB Value Register 0 read. -96 dB. -90 dB. -84 dB. -78 dB. -12 dB. -6 dB. -0.375 dB.	0x0	R

DB VALUE REGISTER 1 READ

Address: 0x0D, Reset: 0x00, Name: DBREG1

The core can write data to this register, and the data is automatically converted to a level in dB. The most common use for this register is to determine the rms value of a signal by taking the absolute value, and then performing low-pass filtering and moving the result to the DBREG1 register.

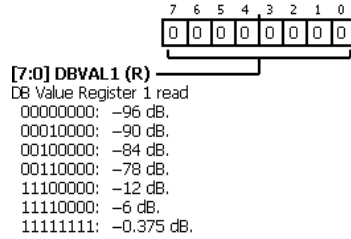

Table 50. Bit Descriptions for DBREG1

Bits	Bit Name	Settings	Description	Reset	Access
[7:0]	DBVAL1		DB Value Register 1 read.	0x0	R
		00000000	-96 dB.		
		00010000	-90 dB.		
		00100000	-84 dB.		
		00110000	-78 dB.		
		11100000	-12 dB.		
		11110000	-6 dB.		
		11111111	-0.375 dB.		

DB VALUE REGISTER 2 READ

Address: 0x0E, Reset: 0x00, Name: DBREG2

The core can write data to this register, and the data is automatically converted to a level in dB. The most common use for this register is to determine the rms value of a signal by taking the absolute value, and then performing low-pass filtering and moving the result to the DBREG2 register.

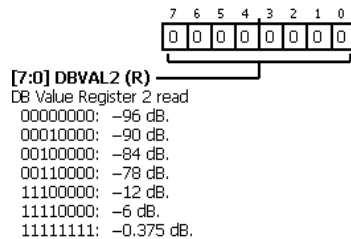

Table 51. Bit Descriptions for DBREG2

Bits	Bit Name	Settings	Description	Reset	Access
[7:0]	DBVAL2		DB Value Register 2 read.	0x0	R
		00000000	-96 dB.		
		00010000	-90 dB.		
		00100000	-84 dB.		
		00110000	-78 dB.		
		11100000	-12 dB.		
		11110000	-6 dB.		
		11111111	-0.375 dB.		

CORE CHANNEL 0/CORE CHANNEL 1 INPUT SELECT REGISTER

Address: 0x0F, Reset: 0x10, Name: CORE_IN_MUX_0_1

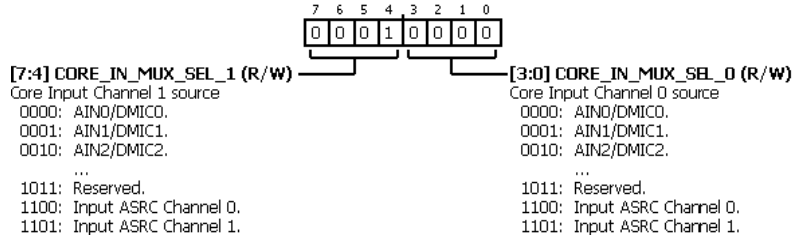

Table 52. Bit Descriptions for CORE_IN_MUX_0_1

Bits	Bit Name	Settings	Description	Reset	Access
[7:4]	CORE_IN_MUX_SEL_1	0000 0001 0010 0011 0100 0101 0110 0111 1000 1001 1010 1011 1100 1101	Core Input Channel 1 source. AIN0/DMIC0. AIN1/DMIC1. AIN2/DMIC2. AIN3/DMIC3. Reserved. Reserved. Reserved. Reserved. Reserved. Reserved. Reserved. Reserved. Input ASRC Channel 0. Input ASRC Channel 1.	0x1	R/W
[3:0]	CORE_IN_MUX_SEL_0	0000 0001 0010 0011 0100 0101 0110 0111 1000 1001 1010 1011 1100 1101	Core Input Channel 0 source. AIN0/DMIC0. AIN1/DMIC1. AIN2/DMIC2. AIN3/DMIC3. Reserved. Reserved. Reserved. Reserved. Reserved. Reserved. Reserved. Reserved. Input ASRC Channel 0. Input ASRC Channel 1.	0x0	R/W

CORE CHANNEL 2/CORE CHANNEL 3 INPUT SELECT REGISTER

Address: 0x10, Reset: 0x32, Name: CORE_IN_MUX_2_3

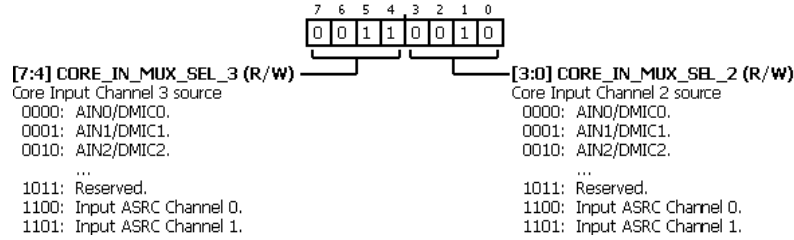

Table 53. Bit Descriptions for CORE_IN_MUX_2_3

Bits	Bit Name	Settings	Description	Reset	Access
[7:4]	CORE_IN_MUX_SEL_3	0000 0001 0010 0011 0100 0101 0110 0111 1000 1001 1010 1011 1100 1101	Core Input Channel 3 source. AIN0/DMIC0. AIN1/DMIC1. AIN2/DMIC2. AIN3/DMIC3. Reserved. Reserved. Reserved. Reserved. Reserved. Reserved. Reserved. Input ASRC Channel 0. Input ASRC Channel 1.	0x3	R/W
[3:0]	CORE_IN_MUX_SEL_2	0000 0001 0010 0011 0100 0101 0110 0111 1000 1001 1010 1011 1100 1101	Core Input Channel 2 source. AIN0/DMIC0. AIN1/DMIC1. AIN2/DMIC2. AIN3/DMIC3. Reserved. Reserved. Reserved. Reserved. Reserved. Reserved. Reserved. Input ASRC Channel 0. Input ASRC Channel 1.	0x2	R/W

DAC INPUT SELECT REGISTER

Address: 0x11, Reset: 0x10, Name: DAC_SOURCE_0_1

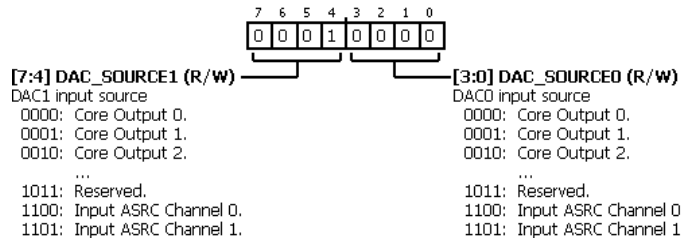

Table 54. Bit Descriptions for DAC_SOURCE_0_1

Bits	Bit Name	Settings	Description	Reset	Access
[7:4]	DAC_SOURCE1		DAC1 input source. Do not change this setting while the core is running. CORE_RUN must be set to 0 for this setting to be updated.	0x1	R/W
		0000	Core Output 0.		
		0001	Core Output 1.		
		0010	Core Output 2.		
		0011	Core Output 3.		
		0100	Reserved.		
		0101	Reserved.		
		0110	Reserved.		
		0111	Reserved.		
		1000	Reserved.		
		1001	Reserved.		
		1010	Reserved.		
		1011	Reserved.		
		1100	Input ASRC Channel 0.		
		1101	Input ASRC Channel 1.		
[3:0]	DAC_SOURCE0		DAC0 input source. Do not change this setting while the core is running. CORE_RUN must be set to 0 for this setting to be updated.	0x0	R/W
		0000	Core Output 0.		
		0001	Core Output 1.		
		0010	Core Output 2.		
		0011	Core Output 3.		
		0100	Reserved.		
		0101	Reserved.		
		0110	Reserved.		
		0111	Reserved.		
		1000	Reserved.		
		1001	Reserved.		
		1010	Reserved.		
		1011	Reserved.		
		1100	Input ASRC Channel 0.		
		1101	Input ASRC Channel 1.		

PDM MODULATOR INPUT SELECT REGISTER

Address: 0x12, Reset: 0x32, Name: PDM_SOURCE_0_1

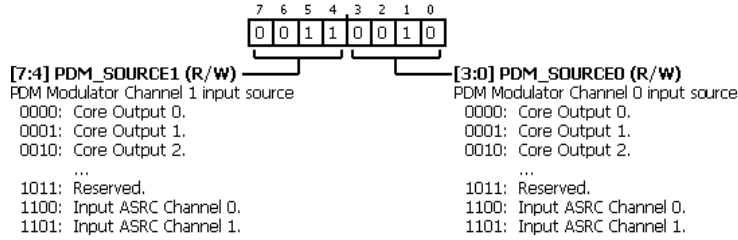

Table 55. Bit Descriptions for PDM_SOURCE_0_1

Bits	Bit Name	Settings	Description	Reset	Access
[7:4]	PDM_SOURCE1	0000 0001 0010 0011 0100 0101 0110 0111 1000 1001 1010 1011 1100 1101	PDM Modulator Channel 1 input source. Core Output 0. Core Output 1. Core Output 2. Core Output 3. Reserved. Reserved. Reserved. Reserved. Reserved. Reserved. Reserved. Reserved. Input ASRC Channel 0. Input ASRC Channel 1.	0x3	R/W
[3:0]	PDM_SOURCE0	0000 0001 0010 0011 0100 0101 0110 0111 1000 1001 1010 1011 1100 1101	PDM Modulator Channel 0 input source. Core Output 0. Core Output 1. Core Output 2. Core Output 3. Reserved. Reserved. Reserved. Reserved. Reserved. Reserved. Reserved. Reserved. Input ASRC Channel 0. Input ASRC Channel 1.	0x2	R/W

SERIAL DATA OUTPUT 0/SERIAL DATA OUTPUT 1 INPUT SELECT REGISTER

Address: 0x13, Reset: 0x54, Name: SOUT_SOURCE_0_1

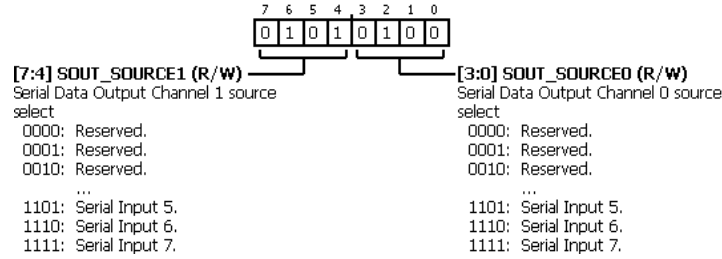

Table 56. Bit Descriptions for SOUT_SOURCE_0_1

Bits	Bit Name	Settings	Description	Reset	Access
[7:4]	SOUT_SOURCE1		Serial Data Output Channel 1 source select.	0x5	R/W
		0000	Reserved.		
		0001	Reserved.		
		0010	Reserved.		
		0011	Reserved.		
		0100	Output ASRC Channel 0.		
		0101	Output ASRC Channel 1.		
		0110	Output ASRC Channel 2.		
		0111	Output ASRC Channel 3.		
		1000	Serial Input 0.		
		1001	Serial Input 1.		
		1010	Serial Input 2.		
		1011	Serial Input 3.		
		1100	Serial Input 4.		
		1101	Serial Input 5.		
		1110	Serial Input 6.		
		1111	Serial Input 7.		
[3:0]	SOUT_SOURCE0		Serial Data Output Channel 0 source select.	0x4	R/W
		0000	Reserved.		
		0001	Reserved.		
		0010	Reserved.		
		0011	Reserved.		
		0100	Output ASRC Channel 0.		
		0101	Output ASRC Channel 1.		
		0110	Output ASRC Channel 2.		
		0111	Output ASRC Channel 3.		
		1000	Serial Input 0.		
		1001	Serial Input 1.		
		1010	Serial Input 2.		
		1011	Serial Input 3.		
		1100	Serial Input 4.		
		1101	Serial Input 5.		
		1110	Serial Input 6.		
		1111	Serial Input 7.		

SERIAL DATA OUTPUT 2/SERIAL DATA OUTPUT 3 INPUT SELECT REGISTER

Address: 0x14, Reset: 0x76, Name: SOUT_SOURCE_2_3

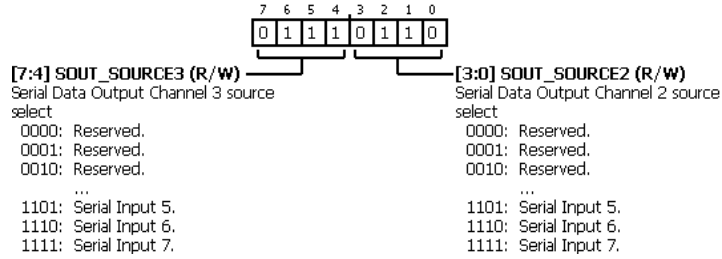

Table 57. Bit Descriptions for SOUT_SOURCE_2_3

Bits	Bit Name	Settings	Description	Reset	Access
[7:4]	SOUT_SOURCE3		Serial Data Output Channel 3 source select.	0x7	R/W
		0000	Reserved.		
		0001	Reserved.		
		0010	Reserved.		
		0011	Reserved.		
		0100	Output ASRC Channel 0.		
		0101	Output ASRC Channel 1.		
		0110	Output ASRC Channel 2.		
		0111	Output ASRC Channel 3.		
		1000	Serial Input 0.		
		1001	Serial Input 1.		
		1010	Serial Input 2.		
		1011	Serial Input 3.		
		1100	Serial Input 4.		
		1101	Serial Input 5.		
		1110	Serial Input 6.		
		1111	Serial Input 7.		
[3:0]	SOUT_SOURCE2		Serial Data Output Channel 2 source select.	0x6	R/W
		0000	Reserved.		
		0001	Reserved.		
		0010	Reserved.		
		0011	Reserved.		
		0100	Output ASRC Channel 0.		
		0101	Output ASRC Channel 1.		
		0110	Output ASRC Channel 2.		
		0111	Output ASRC Channel 3.		
		1000	Serial Input 0.		
		1001	Serial Input 1.		
		1010	Serial Input 2.		
		1011	Serial Input 3.		
		1100	Serial Input 4.		
		1101	Serial Input 5.		
		1110	Serial Input 6.		
		1111	Serial Input 7.		

SERIAL DATA OUTPUT 4/SERIAL DATA OUTPUT 5 INPUT SELECT REGISTER

Address: 0x15, Reset: 0x54, Name: SOUT_SOURCE_4_5

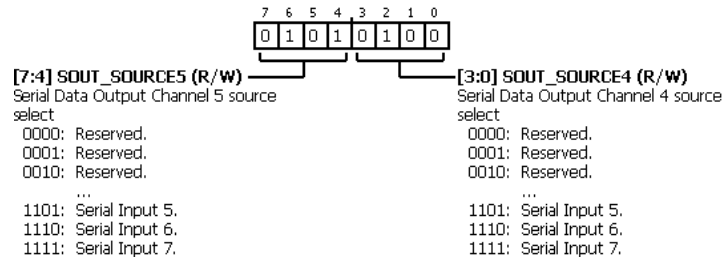

Table 58. Bit Descriptions for SOUT_SOURCE_4_5

Bits	Bit Name	Settings	Description	Reset	Access
[7:4]	SOUT_SOURCE5		Serial Data Output Channel 5 source select.	0x5	R/W
		0000	Reserved.		
		0001	Reserved.		
		0010	Reserved.		
		0011	Reserved.		
		0100	Output ASRC Channel 0.		
		0101	Output ASRC Channel 1.		
		0110	Output ASRC Channel 2.		
		0111	Output ASRC Channel 3.		
		1000	Serial Input 0.		
		1001	Serial Input 1.		
		1010	Serial Input 2.		
		1011	Serial Input 3.		
		1100	Serial Input 4.		
		1101	Serial Input 5.		
		1110	Serial Input 6.		
		1111	Serial Input 7.		
[3:0]	SOUT_SOURCE4		Serial Data Output Channel 4 source select.	0x4	R/W
		0000	Reserved.		
		0001	Reserved.		
		0010	Reserved.		
		0011	Reserved.		
		0100	Output ASRC Channel 0.		
		0101	Output ASRC Channel 1.		
		0110	Output ASRC Channel 2.		
		0111	Output ASRC Channel 3.		
		1000	Serial Input 0.		
		1001	Serial Input 1.		
		1010	Serial Input 2.		
		1011	Serial Input 3.		
		1100	Serial Input 4.		
		1101	Serial Input 5.		
		1110	Serial Input 6.		
		1111	Serial Input 7.		

SERIAL DATA OUTPUT 6/SERIAL DATA OUTPUT 7 INPUT SELECT REGISTER

Address: 0x16, Reset: 0x76, Name: SOUT_SOURCE_6_7

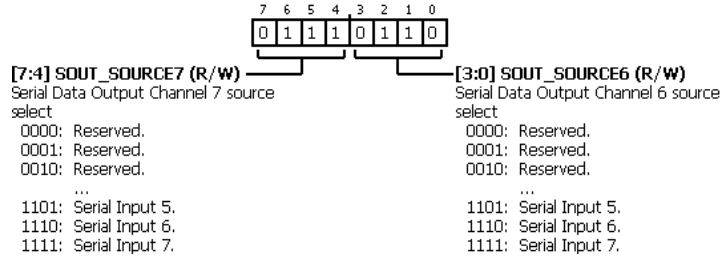

Table 59. Bit Descriptions for SOUT_SOURCE_6_7

Bits	Bit Name	Settings	Description	Reset	Access
[7:4]	SOUT_SOURCE7		Serial Data Output Channel 7 source select.	0x7	R/W
		0000	Reserved.		
		0001	Reserved.		
		0010	Reserved.		
		0011	Reserved.		
		0100	Output ASRC Channel 0.		
		0101	Output ASRC Channel 1.		
		0110	Output ASRC Channel 2.		
		0111	Output ASRC Channel 3.		
		1000	Serial Input 0.		
		1001	Serial Input 1.		
		1010	Serial Input 2.		
		1011	Serial Input 3.		
		1100	Serial Input 4.		
		1101	Serial Input 5.		
		1110	Serial Input 6.		
		1111	Serial Input 7.		
[3:0]	SOUT_SOURCE6		Serial Data Output Channel 6 source select.	0x6	R/W
		0000	Reserved.		
		0001	Reserved.		
		0010	Reserved.		
		0011	Reserved.		
		0100	Output ASRC Channel 0.		
		0101	Output ASRC Channel 1.		
		0110	Output ASRC Channel 2.		
		0111	Output ASRC Channel 3.		
		1000	Serial Input 0.		
		1001	Serial Input 1.		
		1010	Serial Input 2.		
		1011	Serial Input 3.		
		1100	Serial Input 4.		
		1101	Serial Input 5.		
		1110	Serial Input 6.		
		1111	Serial Input 7.		

ADC_SDATA0/ADC_SDATA1 CHANNEL SELECT REGISTER

Address: 0x17, Reset: 0x04, Name: ADC_SDATA_CH

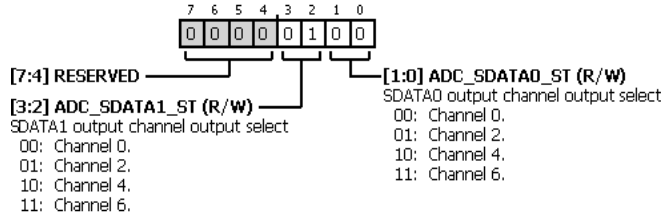

Table 60. Bit Descriptions for ADC_SDATA_CH

Bits	Bit Name	Settings	Description	Reset	Access
[7:4]	RESERVED		Reserved.	0x0	R/W
[3:2]	ADC_SDATA1_ST	00 01 10 11	SDATA1 output channel output select. These bits select the output channel at which ADC_SDATA1 starts to output data. The output port sequentially outputs data following this start channel according to the setting of Bit SAI. Channel 0. Channel 2. Channel 4. Channel 6.	0x1	R/W
[1:0]	ADC_SDATA0_ST	00 01 10 11	SDATA0 output channel output select. These bits select the output channel at which ADC_SDATA0 starts to output data. The output port sequentially outputs data following this start channel according to the setting of Bit SAI. Channel 0. Channel 2. Channel 4. Channel 6.	0x0	R/W

OUTPUT ASRC0/OUTPUT ASRC1 SOURCE REGISTER

Address: 0x18, Reset: 0x10, Name: ASRCO_SOURCE_0_1

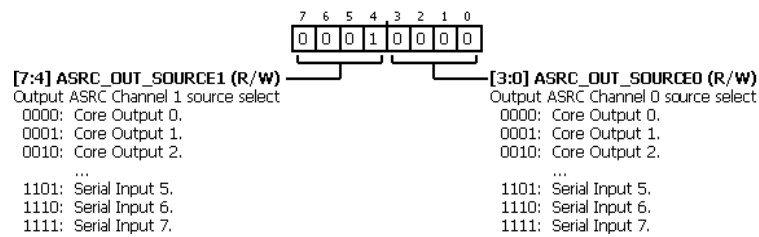

Table 61. Bit Descriptions for ASRCO_SOURCE_0_1

Bits	Bit Name	Settings	Description	Reset	Access
[7:4]	ASRC_OUT_SOURCE1	0000 0001 0010 0011 0100 0101 0110 0111	Output ASRC Channel 1 source select. Core Output 0. Core Output 1. Core Output 2. Core Output 3. ADC0. ADC1. ADC2. ADC3.	0x1	R/W

Bits	Bit Name	Settings	Description	Reset	Access
		1000	Serial Input 0.		
		1001	Serial Input 1.		
		1010	Serial Input 2.		
		1011	Serial Input 3.		
		1100	Serial Input 4.		
		1101	Serial Input 5.		
		1110	Serial Input 6.		
		1111	Serial Input 7.		
[3:0]	ASRC_OUT_SOURCE0		Output ASRC Channel 0 source select.	0x0	R/W
		0000	Core Output 0.		
		0001	Core Output 1.		
		0010	Core Output 2.		
		0011	Core Output 3.		
		0100	ADC0.		
		0101	ADC1.		
		0110	ADC2.		
		0111	ADC3.		
		1000	Serial Input 0.		
		1001	Serial Input 1.		
		1010	Serial Input 2.		
		1011	Serial Input 3.		
		1100	Serial Input 4.		
		1101	Serial Input 5.		
		1110	Serial Input 6.		
		1111	Serial Input 7.		

OUTPUT ASRC2/OUTPUT ASRC3 SOURCE REGISTER

Address: 0x19, Reset: 0x32, Name: ASRCO_SOURCE_2_3

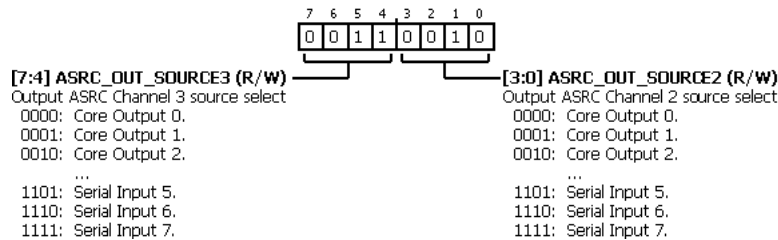

Table 62. Bit Descriptions for ASRCO_SOURCE_2_3

Bits	Bit Name	Settings	Description	Reset	Access
[7:4]	ASRC_OUT_SOURCE3		Output ASRC Channel 3 source select.	0x3	R/W
		0000	Core Output 0.		
		0001	Core Output 1.		
		0010	Core Output 2.		
		0011	Core Output 3.		
		0100	ADC0.		

Bits	Bit Name	Settings	Description	Reset	Access
		0101	ADC1.		
		0110	ADC2.		
		0111	ADC3.		
		1000	Serial Input 0.		
		1001	Serial Input 1.		
		1010	Serial Input 2.		
		1011	Serial Input 3.		
		1100	Serial Input 4.		
		1101	Serial Input 5.		
		1110	Serial Input 6.		
		1111	Serial Input 7.		
[3:0]	ASRC_OUT_SOURCE2		Output ASRC Channel 2 source select.	0x2	R/W
		0000	Core Output 0.		
		0001	Core Output 1.		
		0010	Core Output 2.		
		0011	Core Output 3.		
		0100	ADC0.		
		0101	ADC1.		
		0110	ADC2.		
		0111	ADC3.		
		1000	Serial Input 0.		
		1001	Serial Input 1.		
		1010	Serial Input 2.		
		1011	Serial Input 3.		
		1100	Serial Input 4.		
		1101	Serial Input 5.		
		1110	Serial Input 6.		
		1111	Serial Input 7.		

INPUT ASRC CHANNEL SELECT REGISTER

Address: 0x1A, Reset: 0x00, Name: ASRC_MODE

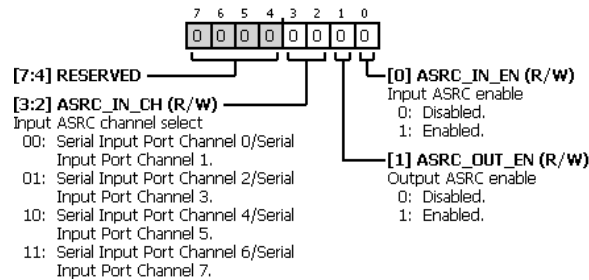

Table 63. Bit Descriptions for ASRC_MODE

Bits	Bit Name	Settings	Description	Reset	Access
[7:4]	RESERVED		Reserved.	0x0	R/W
[3:2]	ASRC_IN_CH	00 01 10 11	Input ASRC channel select. Serial Input Port Channel 0/Serial Input Port Channel 1. Serial Input Port Channel 2/Serial Input Port Channel 3. Serial Input Port Channel 4/Serial Input Port Channel 5. Serial Input Port Channel 6/Serial Input Port Channel 7.	0x0	R/W
1	ASRC_OUT_EN	0 1	Output ASRC enable. Disabled. Enabled.	0x0	R/W
0	ASRC_IN_EN	0 1	Input ASRC enable. Disabled. Enabled.	0x0	R/W

ADC0/ADC1 CONTROL 0 REGISTER

Address: 0x1B, Reset: 0x19, Name: ADC_CONTROL0

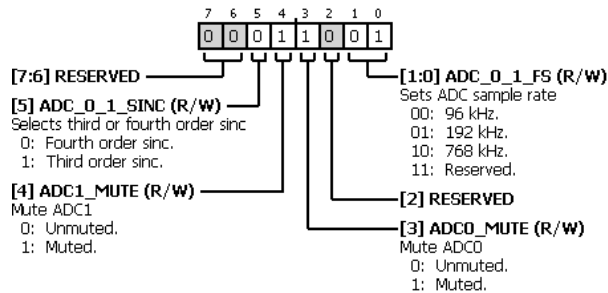

Table 64. Bit Descriptions for ADC_CONTROL0

Bits	Bit Name	Settings	Description	Reset	Access
[7:6]	RESERVED		Reserved.	0x0	R/W
5	ADC_0_1_SINC	0 1	Selects third- or fourth-order sinc. Do not change this setting while the core is running. CORE_RUN must be set to 0 for this setting to be updated. Fourth-order sinc. Third-order sinc.	0x0	R/W
4	ADC1_MUTE	0 1	Mute ADC1. Muting is accomplished by setting the volume control to maximum attenuation. This bit has no effect if volume control is bypassed. Unmuted. Muted.	0x1	R/W
3	ADC0_MUTE	0 1	Mute ADC0. Muting is accomplished by setting the volume control to maximum attenuation. This bit has no effect if volume control is bypassed. Unmuted. Muted.	0x1	R/W
2	RESERVED		Reserved.	0x0	R/W

Bits	Bit Name	Settings	Description	Reset	Access
[1:0]	ADC_0_1_FS		Sets ADC sample rate. The settings of these bits must be consistent with the settings of the FAST_SLOW_RATE bits, and CORE_RUN must be set to 0 for this setting to be updated.	0x1	R/W
		00	96 kHz.		
		01	192 kHz.		
		10	768 kHz.		
		11	Reserved.		

ADC2/ADC3 CONTROL 0 REGISTER

Address: 0x1C, Reset: 0x19, Name: ADC_CONTROL1

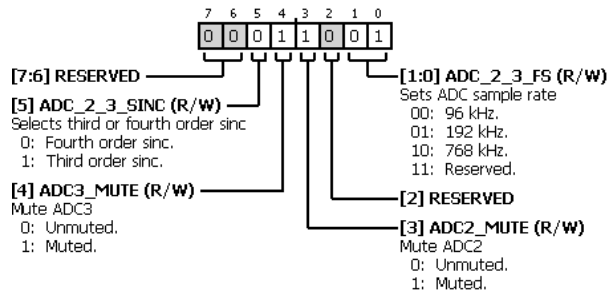

Table 65. Bit Descriptions for ADC_CONTROL1

Bits	Bit Name	Settings	Description	Reset	Access
[7:6]	RESERVED		Reserved.	0x0	R/W
5	ADC_2_3_SINC		Selects third- or fourth-order sinc. Do not change this setting while the core is running. CORE_RUN must be set to 0 for this setting to be updated.	0x0	R/W
		0	Fourth-order sinc.		
		1	Third-order sinc.		
4	ADC3_MUTE		Mute ADC3.	0x1	R/W
		0	Unmuted.		
		1	Muted.		
3	ADC2_MUTE		Mute ADC2. Muting is accomplished by setting the volume control to maximum attenuation. This bit has no effect if volume control is bypassed.	0x1	R/W
		0	Unmuted.		
		1	Muted.		
2	RESERVED		Reserved.	0x0	R/W
[1:0]	ADC_2_3_FS		Sets ADC sample rate. The settings of these bits must be consistent with the settings of the FAST_SLOW_RATE bits, and CORE_RUN must be set to 0 for this setting to be updated.	0x1	R/W
		00	96 kHz.		
		01	192 kHz.		
		10	768 kHz.		
		11	Reserved.		

ADC0/ADC1 CONTROL 1 REGISTER

Address: 0x1D, Reset: 0x00, Name: ADC_CONTROL2

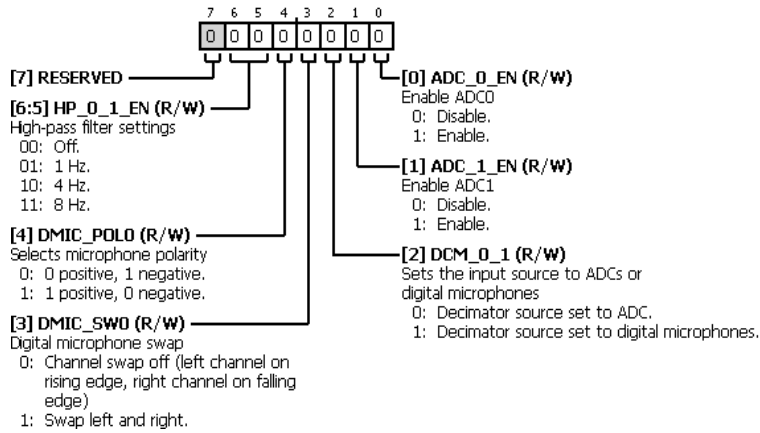

Table 66. Bit Descriptions for ADC_CONTROL2

Bits	Bit Name	Settings	Description	Reset	Access
7	RESERVED		Reserved.	0x0	R/W
[6:5]	HP_0_1_EN	00 01 10 11	High-pass filter settings. Off. 1 Hz. 4 Hz. 8 Hz.	0x0	R/W
4	DMIC_POLO	0 1	Selects microphone polarity. 0 positive, 1 negative. 1 positive, 0 negative.	0x0	R/W
3	DMIC_SWO	0 1	Digital microphone swap. Channel swap off (left channel on rising edge, right channel on falling edge). Swap left and right.	0x0	R/W
2	DCM_0_1	0 1	Sets the input source to ADCs or digital microphones. Decimator source set to ADC. Decimator source set to digital microphones.	0x0	R/W
1	ADC_1_EN	0 1	Enable ADC1. This bit must be set in conjunction with the SINC_1_EN bit in the DECIM_PWR_MODES register to fully enable or disable the ADC. Disable. Enable.	0x0	R/W
0	ADC_0_EN	0 1	Enable ADC0. This bit must be set in conjunction with the SINC_0_EN bit in the DECIM_PWR_MODES register to fully enable or disable the ADC. Disable. Enable.	0x0	R/W

ADC2/ADC3 CONTROL 1 REGISTER

Address: 0x1E, Reset: 0x00, Name: ADC_CONTROL3

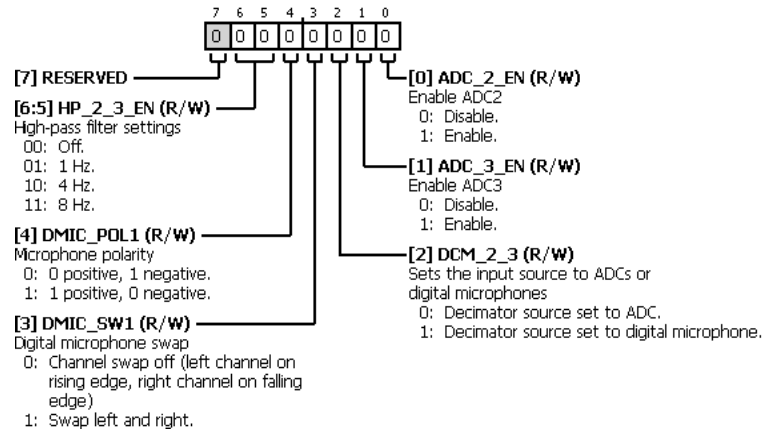

Table 67. Bit Descriptions for ADC_CONTROL3

Bits	Bit Name	Settings	Description	Reset	Access
7	RESERVED		Reserved.	0x0	R/W
[6:5]	HP_2_3_EN	00 01 10 11	High-pass filter settings. Off. 1 Hz. 4 Hz. 8 Hz.	0x0	R/W
4	DMIC_POL1	0 1	Microphone polarity. 0 positive, 1 negative. 1 positive, 0 negative.	0x0	R/W
3	DMIC_SW1	0 1	Digital microphone swap. Channel swap off (left channel on rising edge, right channel on falling edge). Swap left and right.	0x0	R/W
2	DCM_2_3	0 1	Sets the input source to ADCs or digital microphones. Decimator source set to ADC. Decimator source set to digital microphone.	0x0	R/W
1	ADC_3_EN	0 1	Enable ADC3. This bit must be set in conjunction with the SINC_3_EN bit in the DECIM_PWR_MODES register to fully enable or disable the ADC. Disable. Enable.	0x0	R/W
0	ADC_2_EN	0 1	Enable ADC2. This bit must be set in conjunction with the SINC_2_EN bit in the DECIM_PWR_MODES register to fully enable or disable the ADC. Disable. Enable.	0x0	R/W

ADC0 VOLUME CONTROL REGISTER

Address: 0x1F, Reset: 0x00, Name: ADC0_VOLUME

When SINC_0_EN is set, the volume starts to ramp from -95.625 dB to the value in this register. The volume ramp time is (number of steps) $\times 16/f_s$, where there are 256 steps between 0 dB and -95.625 dB. For example, with $f_s = 192$ kHz, the volume ramps from -95.625 dB to 0 dB in 21 ms.

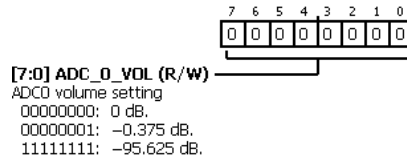

Table 68. Bit Descriptions for ADC0_VOLUME

Bits	Bit Name	Settings	Description	Reset	Access
[7:0]	ADC_0_VOL		ADC0 volume setting.	0x0	R/W
		00000000	0 dB.		
		00000001	-0.375 dB.		
		11111111	-95.625 dB.		

ADC1 VOLUME CONTROL REGISTER

Address: 0x20, Reset: 0x00, Name: ADC1_VOLUME

When SINC_1_EN is set, the volume starts to ramp from -95.625 dB to the value in this register. The volume ramp time is (number of steps) × 16/fs, where there are 256 steps between 0 dB and -95.625 dB. For example, with fs = 192 kHz, the volume ramps from -95.625 dB to 0 dB in 21 ms.

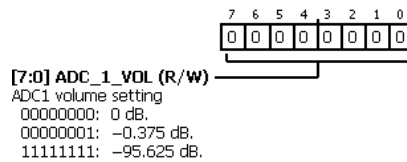

Table 69. Bit Descriptions for ADC1_VOLUME

Bits	Bit Name	Settings	Description	Reset	Access
[7:0]	ADC_1_VOL		ADC1 volume setting.	0x0	R/W
		00000000	0 dB.		
		00000001	-0.375 dB.		
		11111111	-95.625 dB.		

ADC2 VOLUME CONTROL REGISTER

Address: 0x21, Reset: 0x00, Name: ADC2_VOLUME

When SINC_2_EN is set, the volume starts to ramp from -95.625 dB to the value in this register. The volume ramp time is (number of steps) × 16/fs, where there are 256 steps between 0 dB and -95.625 dB. For example, with fs = 192 kHz, the volume ramps from -95.625 dB to 0 dB in 21 ms.

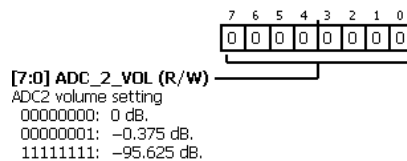
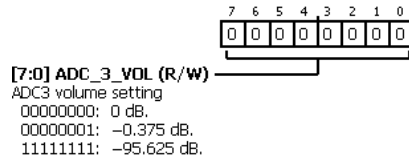

Table 70. Bit Descriptions for ADC2_VOLUME

Bits	Bit Name	Settings	Description	Reset	Access
[7:0]	ADC_2_VOL		ADC2 volume setting.	0x0	R/W
		00000000	0 dB.		
		00000001	-0.375 dB.		
		11111111	-95.625 dB.		

ADC3 VOLUME CONTROL REGISTER**Address: 0x22, Reset: 0x00, Name: ADC3_VOLUME**

When SINC_3_EN is set, the volume starts to ramp from -95.625 dB to the value in this register. The volume ramp time is (number of steps) $\times 16/f_s$, where there are 256 steps between 0 dB and -95.625 dB. For example, with $f_s = 192$ kHz, the volume ramps from -95.625 dB to 0 dB in 21 ms.

**Table 71. Bit Descriptions for ADC3_VOLUME**

Bits	Bit Name	Settings	Description	Reset	Access
[7:0]	ADC_3_VOL		ADC3 volume setting.	0x0	R/W
		00000000	0 dB.		
		00000001	-0.375 dB.		
		11111111	-95.625 dB.		

PGA CONTROL 0 REGISTER**Address: 0x23, Reset: 0x40, Name: PGA_CONTROL_0**

This register controls the PGA connected to AIN0.

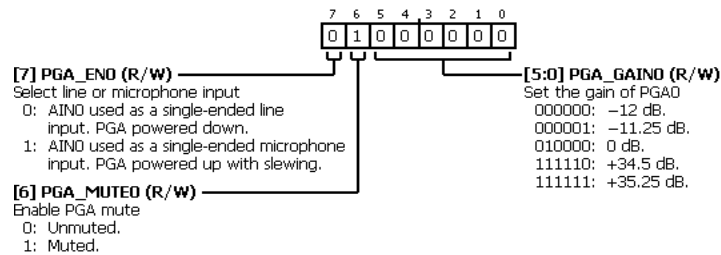
**Table 72. Bit Descriptions for PGA_CONTROL_0**

Bits	Bit Name	Settings	Description	Reset	Access
7	PGA_EN0		Select line or microphone input. Note that the PGA inverts the signal going through it.	0x0	R/W
		0	AIN0 used as a single-ended line input. PGA powered down.		
		1	AIN0 used as a single-ended microphone input. PGA powered up with slewing.		
6	PGA_MUTE0		Enable PGA mute. When PGA is muted, PGA_GAIN0 is ignored.	0x1	R/W
		0	Unmuted.		
		1	Muted.		
[5:0]	PGA_GAIN0		Set the gain of PGA0.	0x0	R/W
		000000	-12 dB.		
		000001	-11.25 dB.		
		010000	0 dB.		
		111110	$+34.5$ dB.		
		111111	$+35.25$ dB.		

PGA CONTROL 1 REGISTER

Address: 0x24, Reset: 0x40, Name: PGA_CONTROL_1

This register controls the PGA connected to AIN1.

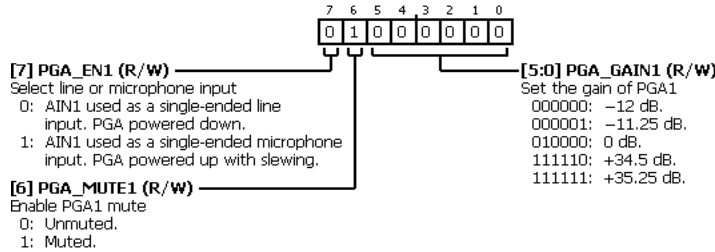

Table 73. Bit Descriptions for PGA_CONTROL_1

Bits	Bit Name	Settings	Description	Reset	Access
7	PGA_EN1	0 1	Select line or microphone input. Note that the PGA inverts the signal going through it. 0 AIN1 used as a single-ended line input. PGA powered down. 1 AIN1 used as a single-ended microphone input. PGA powered up with slewing.	0x0	R/W
6	PGA_MUTE1	0 1	Enable PGA1 mute. When PGA is muted, PGA_GAIN1 is ignored. 0 Unmuted. 1 Muted.	0x1	R/W
[5:0]	PGA_GAIN1	000000 000001 010000 111110 111111	Set the gain of PGA1. -12 dB. -11.25 dB. 0 dB. +34.5 dB. +35.25 dB.	0x0	R/W

PGA CONTROL 2 REGISTER

Address: 0x25, Reset: 0x40, Name: PGA_CONTROL_2

This register controls the PGA connected to AIN2.

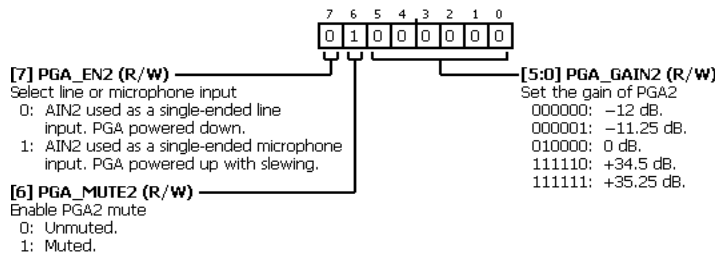

Table 74. Bit Descriptions for PGA_CONTROL_2

Bits	Bit Name	Settings	Description	Reset	Access
7	PGA_EN2	0 1	Select line or microphone input. Note that the PGA inverts the signal going through it. 0 AIN2 used as a single-ended line input. PGA powered down. 1 AIN2 used as a single-ended microphone input. PGA powered up with slewing.	0x0	R/W

Bits	Bit Name	Settings	Description	Reset	Access
6	PGA_MUTE2	0 1	Enable PGA2 mute. When PGA is muted, PGA_GAIN2 is ignored. Unmuted. Muted.	0x1	R/W
[5:0]	PGA_GAIN2	000000 000001 010000 111110 111111	Set the gain of PGA2. -12 dB. -11.25 dB. 0 dB. +34.5 dB. +35.25 dB.	0x0	R/W

PGA CONTROL 3 REGISTER

Address: 0x26, Reset: 0x40, Name: PGA_CONTROL_3

This register controls the PGA connected to AIN3.

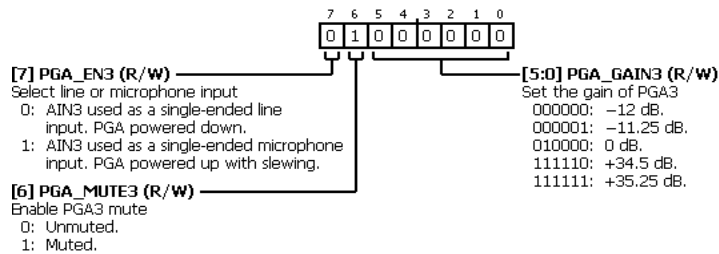

Table 75. Bit Descriptions for PGA_CONTROL_3

Bits	Bit Name	Settings	Description	Reset	Access
7	PGA_EN3	0 1	Select line or microphone input. Note that the PGA inverts the signal going through it. AIN3 used as a single-ended line input. PGA powered down. AIN3 used as a single-ended microphone input. PGA powered up with slewing.	0x0	R/W
6	PGA_MUTE3	0 1	Enable PGA3 mute. When PGA is muted, PGA_GAIN3 is ignored. Unmuted. Muted.	0x1	R/W
[5:0]	PGA_GAIN3	000000 000001 010000 111110 111111	Set the gain of PGA3. -12 dB. -11.25 dB. 0 dB. +34.5 dB. +35.25 dB.	0x0	R/W

PGA SLEW CONTROL REGISTER

Address: 0x27, Reset: 0x00, Name: PGA_STEP_CONTROL

If PGA slew is disabled with the SLEW_PDX controls, the SLEW_RATE parameter is ignored for that PGA block.

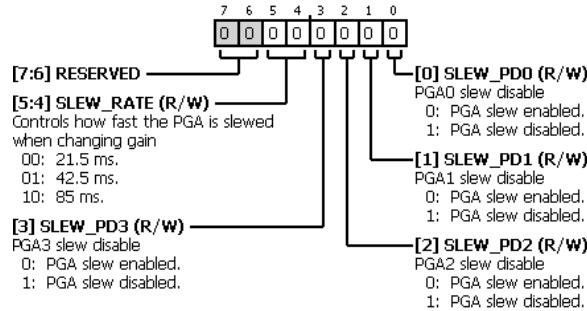

Table 76. Bit Descriptions for PGA_STEP_CONTROL

Bits	Bit Name	Settings	Description	Reset	Access
[7:6]	RESERVED		Reserved.	0x0	R/W
[5:4]	SLEW_RATE	00 01 10	Controls how fast the PGA is slewed when changing gain. 21.5 ms. 42.5 ms. 85 ms.	0x0	R/W
3	SLEW_PD3	0 1	PGA3 slew disable. PGA slew enabled. PGA slew disabled.	0x0	R/W
2	SLEW_PD2	0 1	PGA2 slew disable. PGA slew enabled. PGA slew disabled.	0x0	R/W
1	SLEW_PD1	0 1	PGA1 slew disable. PGA slew enabled. PGA slew disabled.	0x0	R/W
0	SLEW_PD0	0 1	PGA0 slew disable. PGA slew enabled. PGA slew disabled.	0x0	R/W

PGA 10 DB GAIN BOOST REGISTER

Address: 0x28, Reset: 0x00, Name: PGA_10DB_BOOST

Each PGA can have an additional +10 dB gain added, making the PGA gain range -2 dB to +46 dB.

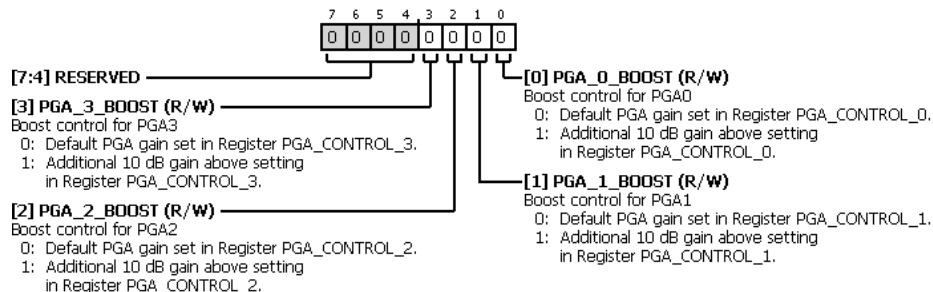

Table 77. Bit Descriptions for PGA_10DB_BOOST

Bits	Bit Name	Settings	Description	Reset	Access
[7:4]	RESERVED		Reserved.	0x0	R/W
3	PGA_3_BOOST	0 1	Boost control for PGA3. Default PGA gain set in Register PGA_CONTROL_3. Additional 10 dB gain above setting in Register PGA_CONTROL_3.	0x0	R/W
2	PGA_2_BOOST	0 1	Boost control for PGA2. Default PGA gain set in Register PGA_CONTROL_2. Additional 10 dB gain above setting in Register PGA_CONTROL_2.	0x0	R/W
1	PGA_1_BOOST	0 1	Boost control for PGA1. Default PGA gain set in Register PGA_CONTROL_1. Additional 10 dB gain above setting in Register PGA_CONTROL_1.	0x0	R/W
0	PGA_0_BOOST	0 1	Boost control for PGA0. Default PGA gain set in Register PGA_CONTROL_0. Additional 10 dB gain above setting in Register PGA_CONTROL_0.	0x0	R/W

INPUT AND OUTPUT CAPACITOR CHARGING REGISTER

Address: 0x29, Reset: 0x3F, Name: POP_SUPPRESS

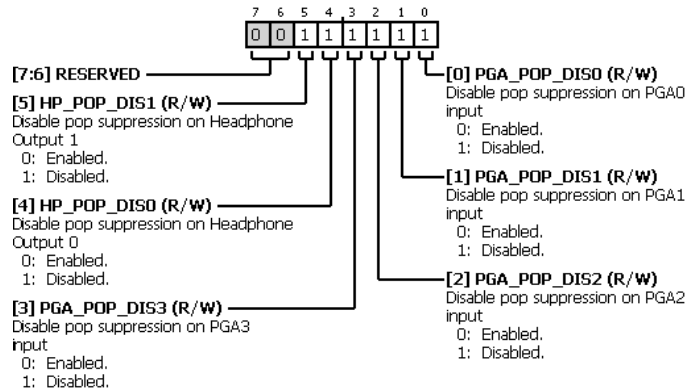

Table 78. Bit Descriptions for POP_SUPPRESS

Bits	Bit Name	Settings	Description	Reset	Access
[7:6]	RESERVED		Reserved.	0x0	R/W
5	HP_POP_DIS1	0 1	Disable pop suppression on Headphone Output 1. Enabled. Disabled.	0x1	R/W
4	HP_POP_DIS0	0 1	Disable pop suppression on Headphone Output 0. Enabled. Disabled.	0x1	R/W
3	PGA_POP_DIS3	0 1	Disable pop suppression on PGA3 input. Enabled. Disabled.	0x1	R/W
2	PGA_POP_DIS2	0 1	Disable pop suppression on PGA2 input. Enabled. Disabled.	0x1	R/W

Bits	Bit Name	Settings	Description	Reset	Access
1	PGA_POP_DIS1	0 1	Disable pop suppression on PGA1 input. Enabled. Disabled.	0x1	R/W
0	PGA_POP_DIS0	0 1	Disable pop suppression on PGA0 input. Enabled. Disabled.	0x1	R/W

DSP BYPASS PATH REGISTER

Address: 0x2A, Reset: 0x00, Name: TALKTHRU

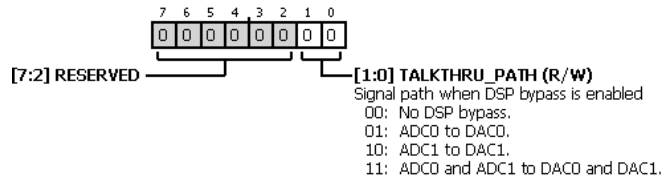

Table 79. Bit Descriptions for TALKTHRU

Bits	Bit Name	Settings	Description	Reset	Access
[7:2]	RESERVED		Reserved.	0x0	R/W
[1:0]	TALKTHRU_PATH	00 01 10 11	Signal path when DSP bypass is enabled. No DSP bypass. ADC0 to DAC0. ADC1 to DAC1. ADC0 and ADC1 to DAC0 and DAC1.	0x0	R/W

DSP BYPASS GAIN FOR PGA0 REGISTER

Address: 0x2B, Reset: 0x00, Name: TALKTHRU_GAIN0

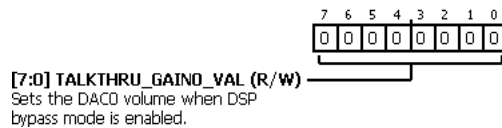

Table 80. Bit Descriptions for TALKTHRU_GAIN0

Bits	Bit Name	Settings	Description	Reset	Access
[7:0]	TALKTHRU_GAIN0_VAL		Sets the DAC0 volume when DSP bypass mode is enabled.	0x0	R/W

DSP BYPASS GAIN FOR PGA1 REGISTER

Address: 0x2C, Reset: 0x00, Name: TALKTHRU_GAIN1

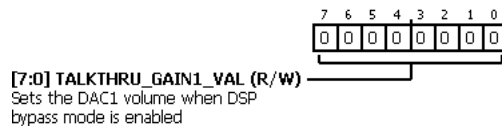

Table 81. Bit Descriptions for TALKTHRU_GAIN1

Bits	Bit Name	Settings	Description	Reset	Access
[7:0]	TALKTHRU_GAIN1_VAL		Sets the DAC1 volume when DSP bypass mode is enabled.	0x0	R/W

MICBIAS0_1 CONTROL REGISTER

Address: 0x2D, Reset: 0x00, Name: MIC_BIAS

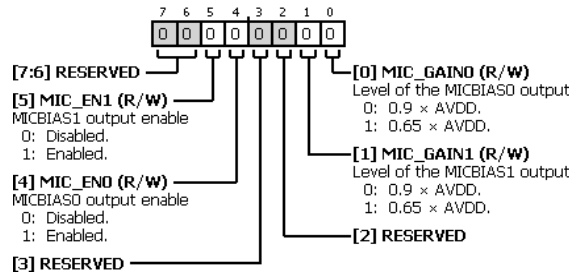

Table 82. Bit Descriptions for MIC_BIAS

Bits	Bit Name	Settings	Description	Reset	Access
[7:6]	RESERVED		Reserved.	0x0	R/W
5	MIC_EN1	0 1	MICBIAS1 output enable. Disabled. Enabled.	0x0	R/W
4	MIC_EN0	0 1	MICBIAS0 output enable. Disabled. Enabled.	0x0	R/W
3	RESERVED		Reserved.	0x0	R/W
2	RESERVED		Reserved.	0x0	R/W
1	MIC_GAIN1	0 1	Level of the MICBIAS1 output. $0.9 \times AVDD$. $0.65 \times AVDD$.	0x0	R/W
0	MIC_GAIN0	0 1	Level of the MICBIAS0 output. $0.9 \times AVDD$. $0.65 \times AVDD$.	0x0	R/W

DAC CONTROL REGISTER

Address: 0x2E, Reset: 0x18, Name: DAC_CONTROL1

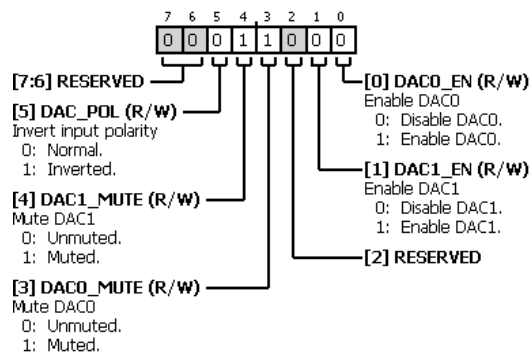

Table 83. Bit Descriptions for DAC_CONTROL1

Bits	Bit Name	Settings	Description	Reset	Access
[7:6]	RESERVED		Reserved.	0x0	R/W

Bits	Bit Name	Settings	Description	Reset	Access
5	DAC_POL	0 1	Invert input polarity. Normal. Inverted.	0x0	R/W
4	DAC1_MUTE	0 1	Mute DAC1. Unmuted. Muted.	0x1	R/W
3	DAC0_MUTE	0 1	Mute DAC0. Unmuted. Muted.	0x1	R/W
2	RESERVED		Reserved.	0x0	R/W
1	DAC1_EN	0 1	Enable DAC1. Disable DAC1. Enable DAC1.	0x0	R/W
0	DAC0_EN	0 1	Enable DAC0. Disable DAC0. Enable DAC0.	0x0	R/W

DAC0 VOLUME CONTROL REGISTER

Address: 0x2F, Reset: 0x00, Name: DAC0_VOLUME

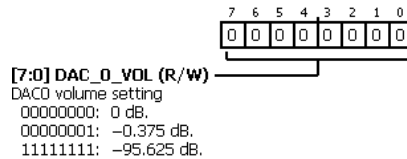

Table 84. Bit Descriptions for DAC0_VOLUME

Bits	Bit Name	Settings	Description	Reset	Access
[7:0]	DAC_0_VOL	00000000 00000001 11111111	DAC0 volume setting. 0 dB. -0.375 dB. -95.625 dB.	0x0	R/W

DAC1 VOLUME CONTROL REGISTER

Address: 0x30, Reset: 0x00, Name: DAC1_VOLUME

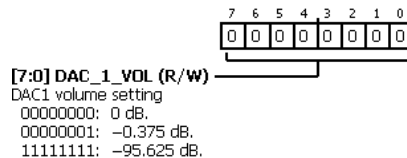

Table 85. Bit Descriptions for DAC1_VOLUME

Bits	Bit Name	Settings	Description	Reset	Access
[7:0]	DAC_1_VOL	00000000 00000001 11111111	DAC1 volume setting. 0 dB. −0.375 dB. −95.625 dB.	0x0	R/W

HEADPHONE OUTPUT MUTES REGISTER

Address: 0x31, Reset: 0x0F, Name: OP_STAGE_MUTES

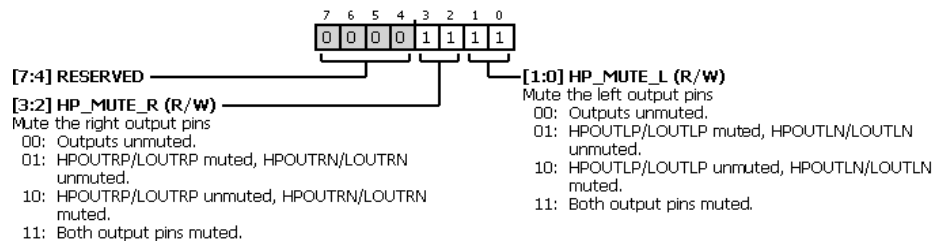

Table 86. Bit Descriptions for OP_STAGE_MUTES

Bits	Bit Name	Settings	Description	Reset	Access
[7:4]	RESERVED		Reserved.	0x0	R/W
[3:2]	HP_MUTE_R	00 01 10 11	Mute the right output pins. When a pin is muted, it can be used as a common-mode output. Outputs unmuted. HPOUTRP/LOUTRP muted, HPOUTRN/LOUTRN unmuted. HPOUTRP/LOUTRP unmuted, HPOUTRN/LOUTRN muted. Both output pins muted.	0x3	R/W
[1:0]	HP_MUTE_L	00 01 10 11	Mute the left output pins. When a pin is muted, it can be used as a common-mode output. Outputs unmuted. HPOUTLP/LOUTLP muted, HPOUTLN/LOUTLN unmuted. HPOUTLP/LOUTLP unmuted, HPOUTLN/LOUTLN muted. Both output pins muted.	0x3	R/W

SERIAL PORT CONTROL 0 REGISTER

Address: 0x32, Reset: 0x00, Name: SAI_0

Using 16-bit serial input/output limits device performance.

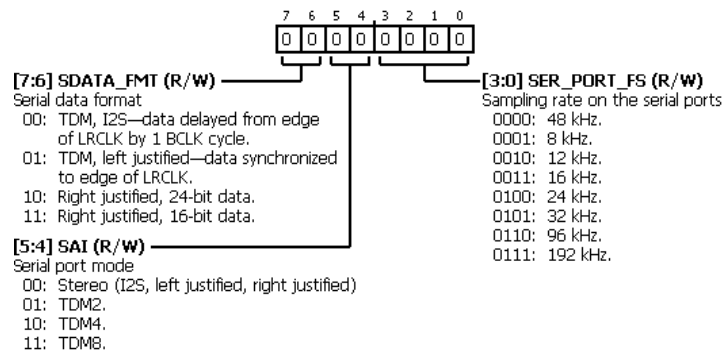

Table 87. Bit Descriptions for SAI_0

Bits	Bit Name	Settings	Description	Reset	Access
[7:6]	SDATA_FMT	00 01 10 11	Serial data format. TDM, I ² S—data delayed from edge of LRCLK by 1 BCLK cycle. TDM, left justified—data synchronized to edge of LRCLK. Right justified, 24-bit data. Right justified, 16-bit data.	0x0	R/W
[5:4]	SAI	00 01 10 11	Serial port mode. Stereo (I ² S, left justified, right justified). TDM2. TDM4. TDM8.	0x0	R/W
[3:0]	SER_PORT_FS	0000 0001 0010 0011 0100 0101 0110 0111	Sampling rate on the serial ports. 48 kHz. 8 kHz. 12 kHz. 16 kHz. 24 kHz. 32 kHz. 96 kHz. 192 kHz.	0x0	R/W

SERIAL PORT CONTROL 1 REGISTER

Address: 0x33, Reset: 0x00, Name: SAI_1

Using 16-bit serial input/output limits device performance.

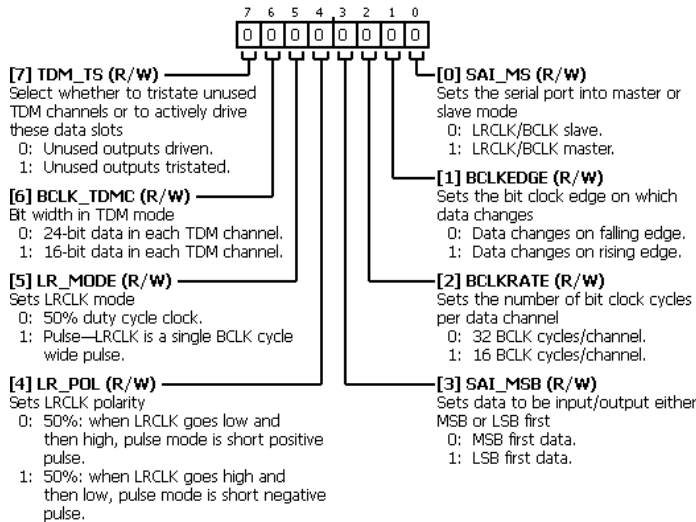

Table 88. Bit Descriptions for SAI_1

Bits	Bit Name	Settings	Description	Reset	Access
7	TDM_TS	0 1	Select whether to tristate unused TDM channels or to actively drive these data slots. Unused outputs driven. Unused outputs tristated.	0x0	R/W

Bits	Bit Name	Settings	Description	Reset	Access
6	BCLK_TDMC		Bit width in TDM mode.	0x0	R/W
		0	24-bit data in each TDM channel.		
		1	16-bit data in each TDM channel.		
5	LR_MODE		Sets LRCLK mode.	0x0	R/W
		0	50% duty cycle clock.		
		1	Pulse—LRCLK is a single BCLK cycle wide pulse.		
4	LR_POL		Sets LRCLK polarity.	0x0	R/W
		0	50%: when LRCLK goes low and then high, pulse mode is short positive pulse.		
		1	50%: when LRCLK goes high and then low, pulse mode is short negative pulse.		
3	SAI_MSB		Sets data to be input/output either MSB or LSB first.	0x0	R/W
		0	MSB first data.		
		1	LSB first data.		
2	BCLKRATE		Sets the number of bit clock cycles per data channel.	0x0	R/W
		0	32 BCLK cycles/channel.		
		1	16 BCLK cycles/channel.		
1	BCLKEDGE		Sets the bit clock edge on which data changes.	0x0	R/W
		0	Data changes on falling edge.		
		1	Data changes on rising edge.		
0	SAI_MS		Sets the serial port into master or slave mode.	0x0	R/W
		0	LRCLK/BCLK slave.		
		1	LRCLK/BCLK master.		

TDM OUTPUT CHANNEL DISABLE REGISTER

Address: 0x34, Reset: 0x00, Name: SOUT_CONTROL0

This register is for use only in TDM mode.

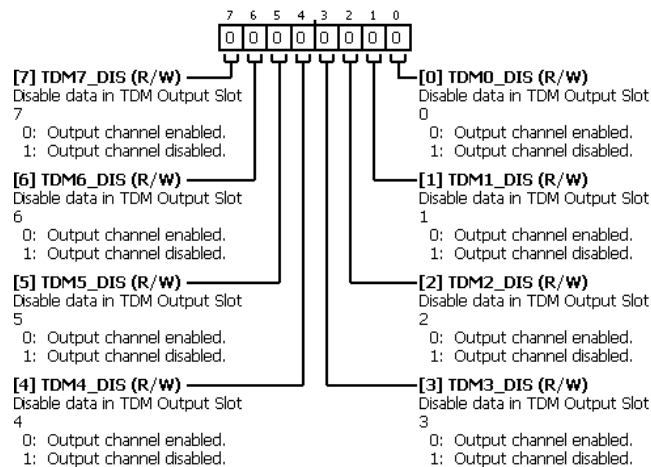

Table 89. Bit Descriptions for SOUT_CONTROL0

Bits	Bit Name	Settings	Description	Reset	Access
7	TDM7_DIS		Disable data in TDM Output Slot 7.	0x0	R/W
		0	Output channel enabled.		
		1	Output channel disabled.		

Bits	Bit Name	Settings	Description	Reset	Access
6	TDM6_DIS	0 1	Disable data in TDM Output Slot 6. Output channel enabled. Output channel disabled.	0x0	R/W
5	TDM5_DIS	0 1	Disable data in TDM Output Slot 5. Output channel enabled. Output channel disabled.	0x0	R/W
4	TDM4_DIS	0 1	Disable data in TDM Output Slot 4. Output channel enabled. Output channel disabled.	0x0	R/W
3	TDM3_DIS	0 1	Disable data in TDM Output Slot 3. Output channel enabled. Output channel disabled.	0x0	R/W
2	TDM2_DIS	0 1	Disable data in TDM Output Slot 2. Output channel enabled. Output channel disabled.	0x0	R/W
1	TDM1_DIS	0 1	Disable data in TDM Output Slot 1. Output channel enabled. Output channel disabled.	0x0	R/W
0	TDM0_DIS	0 1	Disable data in TDM Output Slot 0. Output channel enabled. Output channel disabled.	0x0	R/W

PDM ENABLE REGISTER

Address: 0x36, Reset: 0x00, Name: PDM_OUT

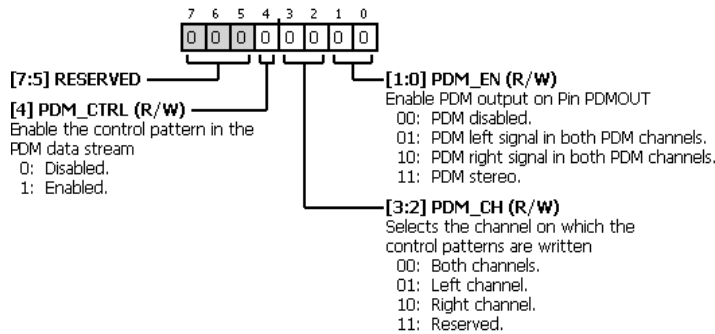

Table 90. Bit Descriptions for PDM_OUT

Bits	Bit Name	Settings	Description	Reset	Access
[7:5]	RESERVED		Reserved.	0x0	R/W
4	PDM_CTRL	0 1	Enable the control pattern in the PDM data stream. Disabled. Enabled.	0x0	R/W

Bits	Bit Name	Settings	Description	Reset	Access
[3:2]	PDM_CH	00 Both channels. 01 Left channel. 10 Right channel. 11 Reserved.	Selects the channel on which the control patterns are written. Do not change these control bits while the PDM channel is operating and transmitting audio.	0x0	R/W
[1:0]	PDM_EN	00 PDM disabled. 01 PDM left signal in both PDM channels. 10 PDM right signal in both PDM channels. 11 PDM stereo.	Enable PDM output on Pin PDMOUT.	0x0	R/W

PDM PATTERN SETTING REGISTER

Address: 0x37, Reset: 0x00, Name: PDM_PATTERN

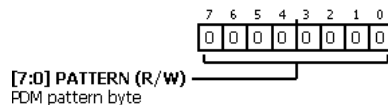

Table 91. Bit Descriptions for PDM_PATTERN

Bits	Bit Name	Settings	Description	Reset	Access
[7:0]	PATTERN		PDM pattern byte. The PDM pattern byte must not be changed while the PDM channel is operating and transmitting the pattern.	0x0	R/W

MPO FUNCTION SETTING REGISTER

Address: 0x38, Reset: 0x00, Name: MODE_MPO

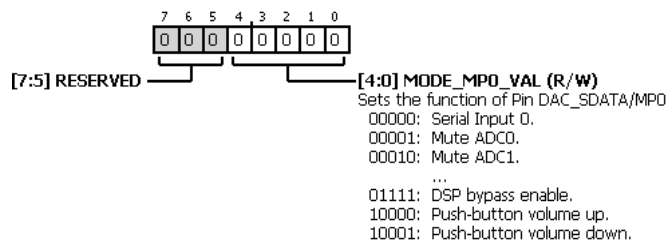

Table 92. Bit Descriptions for MODE_MPO

Bits	Bit Name	Settings	Description	Reset	Access
[7:5]	RESERVED		Reserved.	0x0	R/W
[4:0]	MODE_MPO_VAL	00000 Serial Input 0. 00001 Mute ADC0. 00010 Mute ADC1. 00011 Mute ADC2. 00100 Mute ADC3. 00101 Mute ADC0 and ADC1. 00110 Mute ADC2 and ADC3. 00111 Mute all ADCs.	Sets the function of Pin DAC_SDATA/MPO.	0x0	R/W

Bits	Bit Name	Settings	Description	Reset	Access
		01000	Mute DAC0.		
		01001	Mute DAC1.		
		01010	Mute both DACs.		
		01011	A/B bank switch.		
		01110	Enable compression.		
		01111	DSP bypass enable.		
		10000	Push-button volume up.		
		10001	Push-button volume down.		

MP1 FUNCTION SETTING REGISTER

Address: 0x39, Reset: 0x10, Name: MODE_MP1

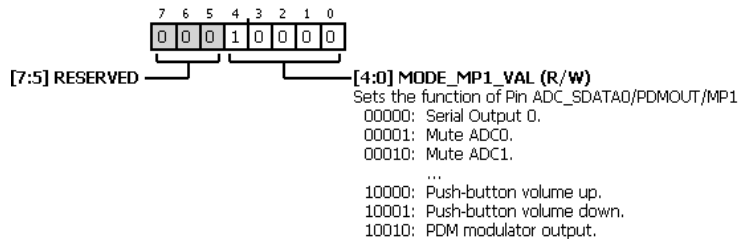

Table 93. Bit Descriptions for MODE_MP1

Bits	Bit Name	Settings	Description	Reset	Access
[7:5]	RESERVED		Reserved.	0x0	R/W
[4:0]	MODE_MP1_VAL		Sets the function of Pin ADC_SDATA0/PDMOUT/MP1.	0x10	R/W
		00000	Serial Output 0.		
		00001	Mute ADC0.		
		00010	Mute ADC1.		
		00011	Mute ADC2.		
		00100	Mute ADC3.		
		00101	Mute ADC0 and ADC1.		
		00110	Mute ADC2 and ADC3.		
		00111	Mute all ADCs.		
		01000	Mute DAC0.		
		01001	Mute DAC1.		
		01010	Mute both DACs.		
		01011	A/B bank switch.		
		01110	Enable compression.		
		01111	DSP bypass enable.		
		10000	Push-button volume up.		
		10001	Push-button volume down.		
		10010	PDM modulator output.		

MP2 FUNCTION SETTING REGISTER

Address: 0x3A, Reset: 0x00, Name: MODE_MP2

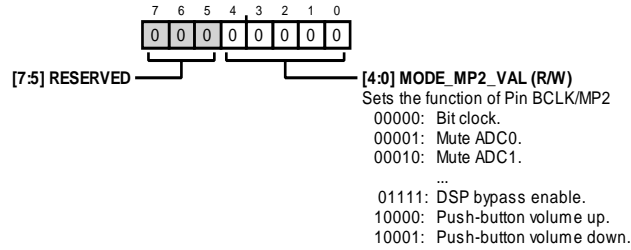

Table 94. Bit Descriptions for MODE_MP2

Bits	Bit Name	Settings	Description	Reset	Access
[7:5]	RESERVED		Reserved.	0x0	R/W
[4:0]	MODE_MP2_VAL	00000 00001 00010 00011 00100 00101 00110 00111 01000 01001 01010 01011 01100 01101 01110 01111 10000 10001	Sets the function of Pin BCLK/MP2 Bit clock. Mute ADC0. Mute ADC1. Mute ADC2. Mute ADC3. Mute ADC0 and ADC1. Mute ADC2 and ADC3. Mute all ADCs. Mute DAC0. Mute DAC1. Mute both DACs. A/B bank switch. Reserved. Reserved. Enable compression. DSP bypass enable. Push-button volume up. Push-button volume down.	0x0	R/W

MP3 FUNCTION SETTING REGISTER

Address: 0x3B, Reset: 0x00, Name: MODE_MP3

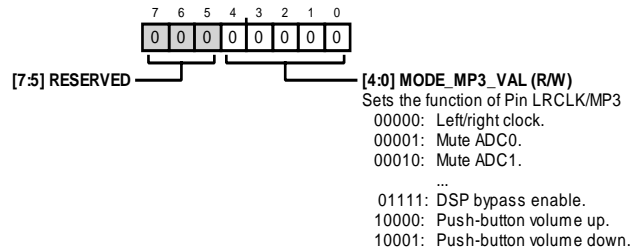

Table 95. Bit Descriptions for MODE_MP3

Bits	Bit Name	Settings	Description	Reset	Access
[7:5]	RESERVED		Reserved.	0x0	R/W

Bits	Bit Name	Settings	Description	Reset	Access
[4:0]	MODE_MP3_VAL	00000 00001 00010 00011 00100 00101 00110 00111 01000 01001 01010 01011 01100 01101 01110 01111 10000 10001	Sets the function of Pin LRCLK/MP3 Left/right clock. Mute ADC0. Mute ADC1. Mute ADC2. Mute ADC3. Mute ADC0 and ADC1. Mute ADC2 and ADC3. Mute all ADCs. Mute DAC0. Mute DAC1. Mute both DACs. A/B bank switch. Reserved. Reserved. Enable compression. DSP bypass enable. Push-button volume up. Push-button volume down.	0x0	R/W

MP4 FUNCTION SETTING REGISTER

Address: 0x3C, Reset: 0x00, Name: MODE_MP4

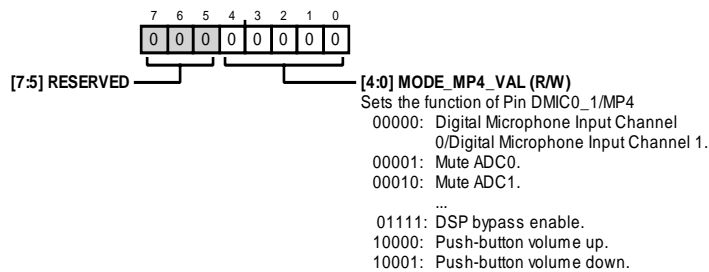

Table 96. Bit Descriptions for MODE_MP4

Bits	Bit Name	Settings	Description	Reset	Access
[7:5]	RESERVED		Reserved.	0x0	R/W
[4:0]	MODE_MP4_VAL	00000 00001 00010 00011 00100 00101 00110 00111 01000	Sets the function of Pin DMIC0_1/MP4 Digital Microphone Input Channel 0/Digital Microphone Input Channel 1. Mute ADC0. Mute ADC1. Mute ADC2. Mute ADC3. Mute ADC0 and ADC1. Mute ADC2 and ADC3. Mute all ADCs. Mute DAC0.	0x0	R/W

Bits	Bit Name	Settings	Description	Reset	Access
		01001	Mute DAC1.		
		01010	Mute both DACs.		
		01011	A/B bank switch.		
		01100	Reserved.		
		01101	Reserved.		
		01110	Enable compression.		
		01111	DSP bypass enable.		
		10000	Push-button volume up.		
		10001	Push-button volume down.		

MP5 FUNCTION SETTING REGISTER

Address: 0x3D, Reset: 0x00, Name: MODE_MP5

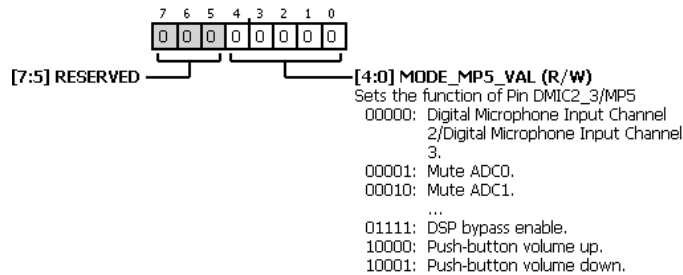

Table 97. Bit Descriptions for MODE_MP5

Bits	Bit Name	Settings	Description	Reset	Access
[7:5]	RESERVED		Reserved.	0x0	R/W
[4:0]	MODE_MP5_VAL		Sets the function of Pin DMIC2_3/MP5.	0x0	R/W
		00000	Digital Microphone Input Channel 2/Digital Microphone Input Channel 3.		
		00001	Mute ADC0.		
		00010	Mute ADC1.		
		00011	Mute ADC2.		
		00100	Mute ADC3.		
		00101	Mute ADC0 and ADC1.		
		00110	Mute ADC2 and ADC3.		
		00111	Mute all ADCs.		
		01000	Mute DAC0.		
		01001	Mute DAC1.		
		01010	Mute both DACs.		
		01011	A/B bank switch.		
		01100	Reserved.		
		01101	Reserved.		
		01110	Enable compression.		
		01111	DSP bypass enable.		
		10000	Push-button volume up.		
		10001	Push-button volume down.		

MP6 FUNCTION SETTING REGISTER

Address: 0x3E, Reset: 0x11, Name: MODE_MP6

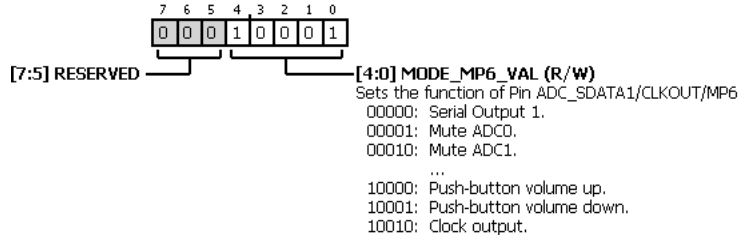

Table 98. Bit Descriptions for MODE_MP6

Bits	Bit Name	Settings	Description	Reset	Access
[7:5]	RESERVED		Reserved.	0x0	R/W
[4:0]	MODE_MP6_VAL	00000 Serial Output 1. 00001 Mute ADC0. 00010 Mute ADC1. 00011 Mute ADC2. 00100 Mute ADC3. 00101 Mute ADC0 and ADC1. 00110 Mute ADC2 and ADC3. 00111 Mute all ADCs. 01000 Mute DAC0. 01001 Mute DAC1. 01010 Mute both DACs. 01011 A/B bank switch. 01100 Reserved. 01101 Reserved. 01110 Enable compression. 01111 DSP bypass enable. 10000 Push-button volume up. 10001 Push-button volume down. 10010 Clock output.	Sets the function of Pin ADC_SDATA1/CLKOUT/MP6.	0x11	R/W

PUSH-BUTTON VOLUME SETTINGS REGISTER

Address: 0x3F, Reset: 0x00, Name: PB_VOL_SET

This register must be written before Bits PB_VOL_CONV_VAL are set to something other than the default value. Otherwise, the push-button volume control is initialized to -96 dB.

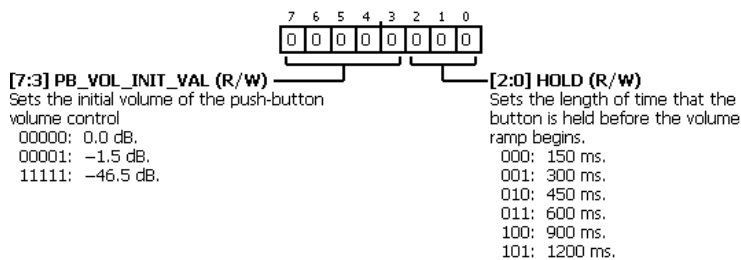

Table 99. Bit Descriptions for PB_VOL_SET

Bits	Bit Name	Settings	Description	Reset	Access
[7:3]	PB_VOL_INIT_VAL	00000 00001 11111	Sets the initial volume of the push-button volume control. Each increment of this register attenuates the level by 1.5 dB, from 0 dB to -46.5 dB. 0.0 dB. -1.5 dB. -46.5 dB.	0x0	R/W
[2:0]	HOLD	000 001 010 011 100 101	Sets the length of time that the button is held before the volume ramp begins. 150 ms. 300 ms. 450 ms. 600 ms. 900 ms. 1200 ms.	0x0	R/W

PUSH-BUTTON VOLUME CONTROL ASSIGNMENT REGISTER

Address: 0x40, Reset: 0x87, Name: PB_VOL_CONV

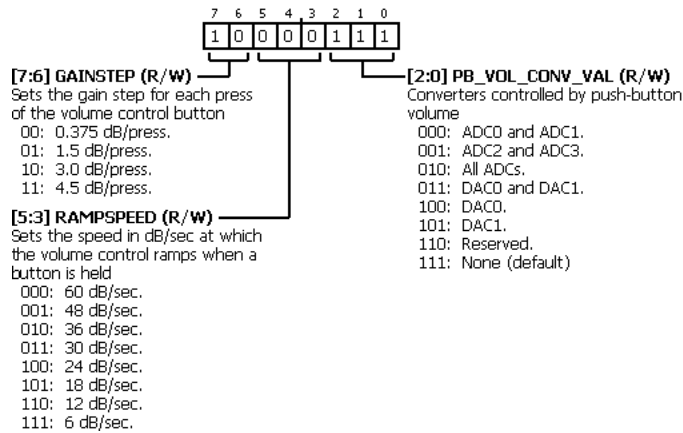

Table 100. Bit Descriptions for PB_VOL_CONV

Bits	Bit Name	Settings	Description	Reset	Access
[7:6]	GAINSTEP	00 01 10 11	Sets the gain step for each press of the volume control button. 0.375 dB/press. 1.5 dB/press. 3.0 dB/press. 4.5 dB/press.	0x2	R/W
[5:3]	RAMPSPEED	000 001 010 011 100 101 110 111	Sets the speed in dB/sec at which the volume control ramps when a button is held. 60 dB/sec. 48 dB/sec. 36 dB/sec. 30 dB/sec. 24 dB/sec. 18 dB/sec. 12 dB/sec. 6 dB/sec.	0x0	R/W

Bits	Bit Name	Settings	Description	Reset	Access
[2:0]	PB_VOL_CONV_VAL		Converters controlled by push-button volume. The push-button volume control is enabled when these bits are set to something other than the default setting (111). When set to 111, the push-button volume is disabled and the converter volumes are set by the ADCx_VOLUME and DACx_VOLUME registers.	0x7	R/W
		000	ADC0 and ADC1.		
		001	ADC2 and ADC3.		
		010	All ADCs.		
		011	DAC0 and DAC1.		
		100	DAC0.		
		101	DAC1.		
		110	Reserved.		
		111	None (default).		

DEBOUNCE MODES REGISTER

Address: 0x41, Reset: 0x05, Name: DEBOUNCE_MODE

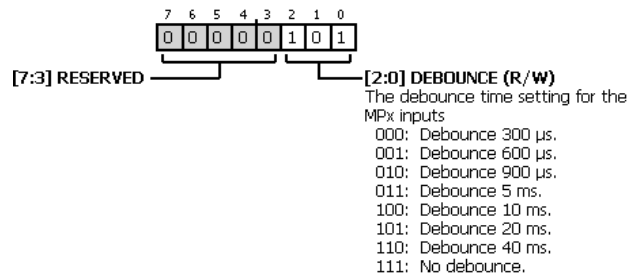
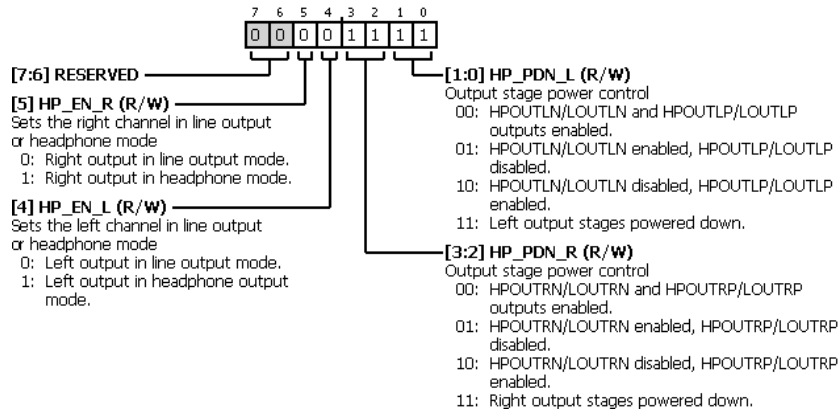

Table 101. Bit Descriptions for DEBOUNCE_MODE

Bits	Bit Name	Settings	Description	Reset	Access
[7:3]	RESERVED		Reserved.	0x0	R/W
[2:0]	DEBOUNCE		The debounce time setting for the MPx inputs.	0x5	R/W
		000	Debounce 300 μs.		
		001	Debounce 600 μs.		
		010	Debounce 900 μs.		
		011	Debounce 5 ms.		
		100	Debounce 10 ms.		
		101	Debounce 20 ms.		
		110	Debounce 40 ms.		
		111	No debounce.		

HEADPHONE LINE OUTPUT SELECT REGISTER

Address: 0x43, Reset: 0x0F, Name: OP_STAGE_CTRL

**Table 102. Bit Descriptions for OP_STAGE_CTRL**

Bits	Bit Name	Settings	Description	Reset	Access
[7:6]	RESERVED		Reserved.	0x0	R/W
5	HP_EN_R	0 1	Sets the right channel in line output or headphone mode. Right output in line output mode. Right output in headphone mode.	0x0	R/W
4	HP_EN_L	0 1	Sets the left channel in line output or headphone mode Left output in line output mode. Left output in headphone output mode.	0x0	R/W
[3:2]	HP_PDN_R	00 01 10 11	Output stage power control. These bits power down the right output stage, regardless of whether the device is in line output or headphone mode. After enabling the headphone output, wait at least 6 ms before unmuting the headphone output by setting HP_MUTE_R in the OP_STAGE_MUTES register to 00. HPOUTRN/LOUTRN and HPOUTRP/LOUTRP outputs enabled. HPOUTRN/LOUTRN enabled, HPOUTRP/LOUTRP disabled. HPOUTRN/LOUTRN disabled, HPOUTRP/LOUTRP enabled. Right output stages powered down.	0x3	R/W
[1:0]	HP_PDN_L	00 01 10 11	Output stage power control. These bits power down the left output stage, regardless of whether the device is in line output or headphone mode. After enabling the headphone output, wait at least 6 ms before unmuting the headphone output by setting HP_MUTE_L in the OP_STAGE_MUTES register to 00. HPOUTLN/LOUTLN and HPOUTLP/LOUTLP outputs enabled. HPOUTLN/LOUTLN enabled, HPOUTLP/LOUTLP disabled. HPOUTLN/LOUTLN disabled, HPOUTLP/LOUTLP enabled. Left output stages powered down.	0x3	R/W

DECIMATOR POWER CONTROL REGISTER

Address: 0x44, Reset: 0x00, Name: DECIM_PWR_MODES

The bits in this register enable clocks to the digital filters and the ASRC decimator filters of the ADCs. These bits must be enabled for all channels used in the design. To use the ADCs, these SINC_x_EN bits must be enabled along with the appropriate ADC_x_EN bits in the ADC_CONTROL2 and ADC_CONTROL3 registers. If the digital microphone inputs are used, the SINC_x_EN bits can be set without setting ADC_x_EN.

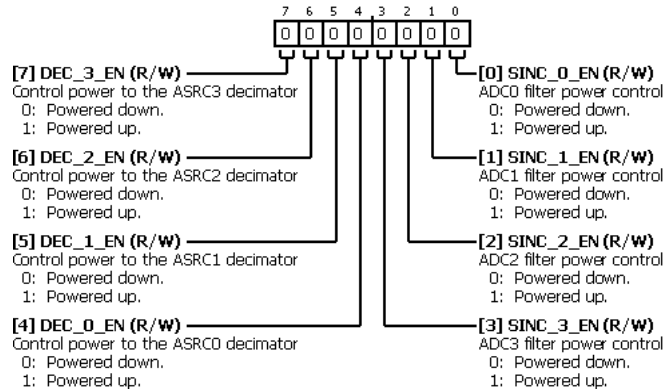

Table 103. Bit Descriptions for DECIM_PWR_MODES

Bits	Bit Name	Settings	Description	Reset	Access
7	DEC_3_EN	0 1	Control power to the ASRC3 decimator. Powered down. Powered up.	0x0	R/W
6	DEC_2_EN	0 1	Control power to the ASRC2 decimator. Powered down. Powered up.	0x0	R/W
5	DEC_1_EN	0 1	Control power to the ASRC1 decimator. Powered down. Powered up.	0x0	R/W
4	DEC_0_EN	0 1	Control power to the ASRC0 decimator. Powered down. Powered up.	0x0	R/W
3	SINC_3_EN	0 1	ADC3 filter power control. Powered down. Powered up.	0x0	R/W
2	SINC_2_EN	0 1	ADC2 filter power control. Powered down. Powered up.	0x0	R/W
1	SINC_1_EN	0 1	ADC1 filter power control. Powered down. Powered up.	0x0	R/W
0	SINC_0_EN	0 1	ADC0 filter power control. Powered down. Powered up.	0x0	R/W

ASRC INTERPOLATOR AND DAC MODULATOR POWER CONTROL REGISTER

Address: 0x45, Reset: 0x00, Name: INTERP_PWR_MODES

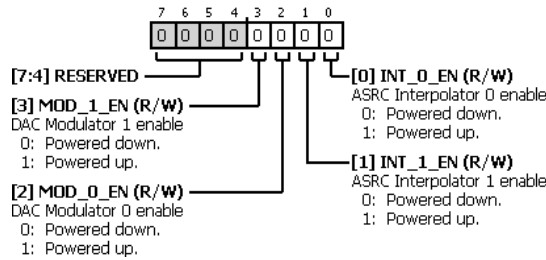

Table 104. Bit Descriptions for INTERP_PWR_MODES

Bits	Bit Name	Settings	Description	Reset	Access
[7:4]	RESERVED		Reserved.	0x0	R/W
3	MOD_1_EN	0 1	DAC Modulator 1 enable. 0: Powered down. 1: Powered up.	0x0	R/W
2	MOD_0_EN	0 1	DAC Modulator 0 enable. 0: Powered down. 1: Powered up.	0x0	R/W
1	INT_1_EN	0 1	ASRC Interpolator 1 enable. 0: Powered down. 1: Powered up.	0x0	R/W
0	INT_0_EN	0 1	ASRC Interpolator 0 enable. 0: Powered down. 1: Powered up.	0x0	R/W

ANALOG BIAS CONTROL 0 REGISTER

Address: 0x46, Reset: 0x00, Name: BIAS_CONTROLO

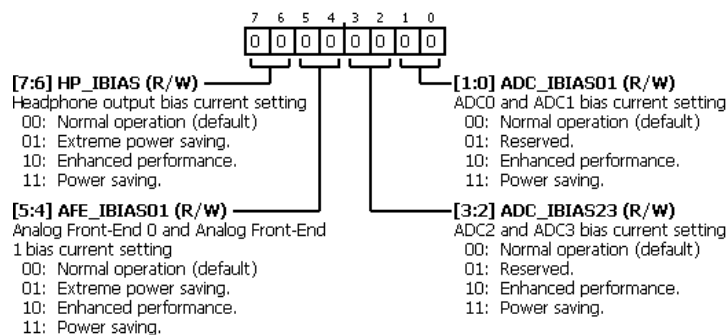

Table 105. Bit Descriptions for BIAS_CONTROLO

Bits	Bit Name	Settings	Description	Reset	Access
[7:6]	HP_IBIAS	00 01 10 11	Headphone output bias current setting. Higher bias currents result in higher performance. 00: Normal operation (default). 01: Extreme power saving. 10: Enhanced performance. 11: Power saving.	0x0	R/W

Bits	Bit Name	Settings	Description	Reset	Access
[5:4]	AFE_IBIAS01	00 01 10 11	Analog Front-End 0 and Analog Front-End 1 bias current setting. Higher bias currents result in higher performance. Normal operation (default). Extreme power saving. Enhanced performance. Power saving.	0x0	R/W
[3:2]	ADC_IBIAS23	00 01 10 11	ADC2 and ADC3 bias current setting. Higher bias currents result in higher performance. Normal operation (default). Reserved. Enhanced performance. Power saving.	0x0	R/W
[1:0]	ADC_IBIAS01	00 01 10 11	ADC0 and ADC1 bias current setting. Higher bias currents result in higher performance. Normal operation (default). Reserved. Enhanced performance. Power saving.	0x0	R/W

ANALOG BIAS CONTROL 1 REGISTER

Address: 0x47, Reset: 0x00, Name: BIAS_CONTROL1

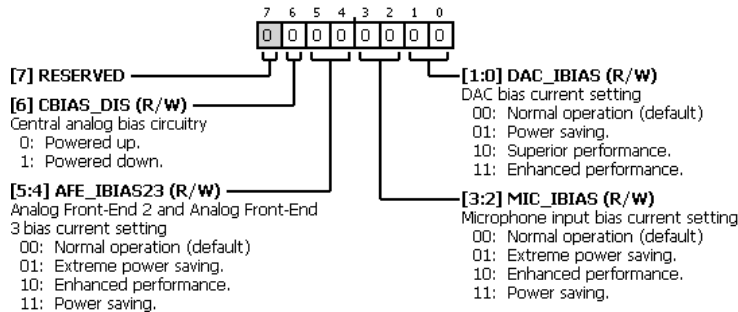

Table 106. Bit Descriptions for BIAS_CONTROL1

Bits	Bit Name	Settings	Description	Reset	Access
7	RESERVED		Reserved.	0x0	R/W
6	CBIAS_DIS	0 1	Central analog bias circuitry. Higher bias currents result in higher performance. Powered up. Powered down.	0x0	R/W
[5:4]	AFE_IBIAS23	00 01 10 11	Analog Front-End 2 and Analog Front-End 3 bias current setting. Higher bias currents result in higher performance. Normal operation (default). Extreme power saving. Enhanced performance. Power saving.	0x0	R/W

Bits	Bit Name	Settings	Description	Reset	Access
[3:2]	MIC_IBIAS	00 01 10 11	Microphone input bias current setting. Higher bias currents result in higher performance. Normal operation (default). Extreme power saving. Enhanced performance. Power saving.	0x0	R/W
[1:0]	DAC_IBIAS	00 01 10 11	DAC bias current setting. Higher bias currents result in higher performance. Normal operation (default). Power saving. Superior performance. Enhanced performance.	0x0	R/W

DIGITAL PIN PULL-UP CONTROL 0 REGISTER

Address: 0x48, Reset: 0x7F, Name: PAD_CONTROL0

Enable pull-up resistors for each digital pin.

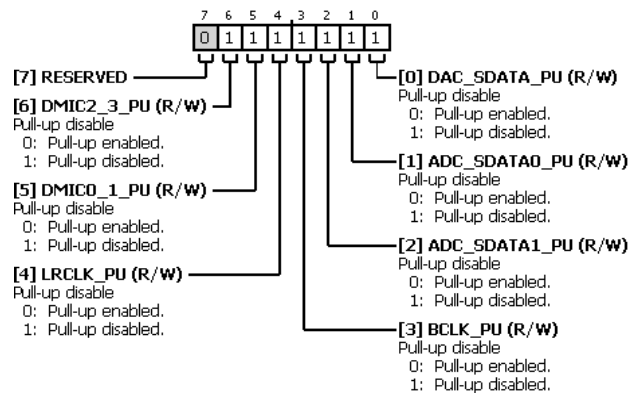

Table 107. Bit Descriptions for PAD_CONTROL0

Bits	Bit Name	Settings	Description	Reset	Access
7	RESERVED		Reserved.	0x0	R/W
6	DMIC2_3_PU	0 1	Pull-up disable. Pull-up enabled. Pull-up disabled.	0x1	R/W
5	DMIC0_1_PU	0 1	Pull-up disable. Pull-up enabled. Pull-up disabled.	0x1	R/W
4	LRCLK_PU	0 1	Pull-up disable. Pull-up enabled. Pull-up disabled.	0x1	R/W
3	BCLK_PU	0 1	Pull-up disable. Pull-up enabled. Pull-up disabled.	0x1	R/W

Bits	Bit Name	Settings	Description	Reset	Access
2	ADC_SDATA1_PU	0 1	Pull-up disable. Pull-up enabled. Pull-up disabled.	0x1	R/W
1	ADC_SDATA0_PU	0 1	Pull-up disable. Pull-up enabled. Pull-up disabled.	0x1	R/W
0	DAC_SDATA_PU	0 1	Pull-up disable. Pull-up enabled. Pull-up disabled.	0x1	R/W

DIGITAL PIN PULL-UP CONTROL 1 REGISTER

Address: 0x49, Reset: 0x1F, Name: PAD_CONTROL1

Enable pull-up resistors for each digital pin.

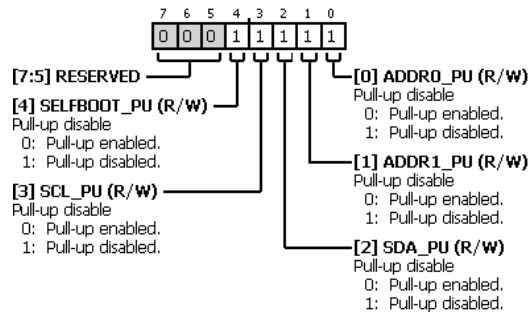

Table 108. Bit Descriptions for PAD_CONTROL1

Bits	Bit Name	Settings	Description	Reset	Access
[7:5]	RESERVED		Reserved.	0x0	R/W
4	SELFBOOT_PU	0 1	Pull-up disable. Pull-up enabled. Pull-up disabled.	0x1	R/W
3	SCL_PU	0 1	Pull-up disable. Pull-up enabled. Pull-up disabled.	0x1	R/W
2	SDA_PU	0 1	Pull-up disable. Pull-up enabled. Pull-up disabled.	0x1	R/W
1	ADDR1_PU	0 1	Pull-up disable. Pull-up enabled. Pull-up disabled.	0x1	R/W
0	ADDR0_PU	0 1	Pull-up disable. Pull-up enabled. Pull-up disabled.	0x1	R/W

DIGITAL PIN PULL-DOWN CONTROL 0 REGISTER

Address: 0x4A, Reset: 0x00, Name: PAD_CONTROL2

Enable pull-down resistors for each digital pin.

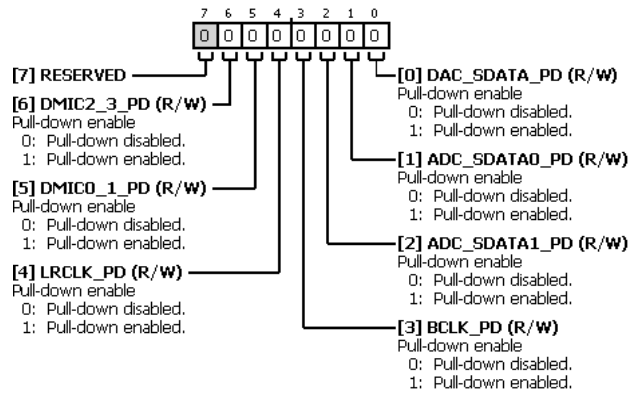

Table 109. Bit Descriptions for PAD_CONTROL2

Bits	Bit Name	Settings	Description	Reset	Access
7	RESERVED		Reserved.	0x0	R/W
6	DMIC2_3_PD	0 1	Pull-down enable. Pull-down disabled. Pull-down enabled.	0x0	R/W
5	DMIC0_1_PD	0 1	Pull-down enable. Pull-down disabled. Pull-down enabled.	0x0	R/W
4	LRCLK_PD	0 1	Pull-down enable. Pull-down disabled. Pull-down enabled.	0x0	R/W
3	BCLK_PD	0 1	Pull-down enable. Pull-down disabled. Pull-down enabled.	0x0	R/W
2	ADC_SDATA1_PD	0 1	Pull-down enable. Pull-down disabled. Pull-down enabled.	0x0	R/W
1	ADC_SDATA0_PD	0 1	Pull-down enable. Pull-down disabled. Pull-down enabled.	0x0	R/W
0	DAC_SDATA_PD	0 1	Pull-down enable. Pull-down disabled. Pull-down enabled.	0x0	R/W

DIGITAL PIN PULL-DOWN CONTROL 1 REGISTER

Address: 0x4B, Reset: 0x00, Name: PAD_CONTROL3

Enable pull-down resistors for each digital pin.

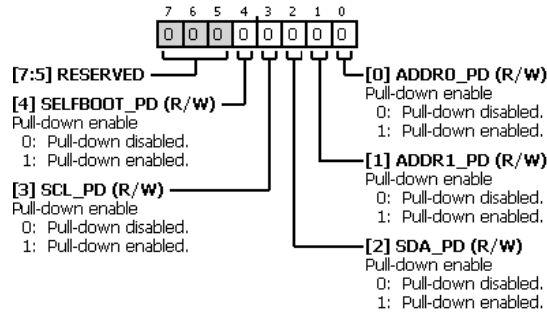

Table 110. Bit Descriptions for PAD_CONTROL3

Bits	Bit Name	Settings	Description	Reset	Access
[7:5]	RESERVED		Reserved.	0x0	R/W
4	SELFBOOT_PD	0 1	Pull-down enable. Pull-down disabled. Pull-down enabled.	0x0	R/W
3	SCL_PD	0 1	Pull-down enable. Pull-down disabled. Pull-down enabled.	0x0	R/W
2	SDA_PD	0 1	Pull-down enable. Pull-down disabled. Pull-down enabled.	0x0	R/W
1	ADDR1_PD	0 1	Pull-down enable. Pull-down disabled. Pull-down enabled.	0x0	R/W
0	ADDR0_PD	0 1	Pull-down enable. Pull-down disabled. Pull-down enabled.	0x0	R/W

DIGITAL PIN DRIVE STRENGTH CONTROL 0 REGISTER

Address: 0x4C, Reset: 0x00, Name: PAD_CONTROL4

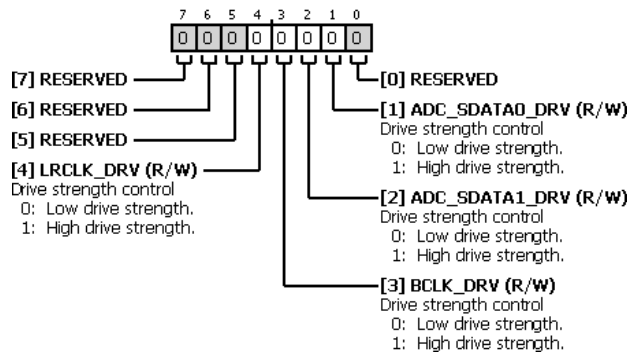

Table 111. Bit Descriptions for PAD_CONTROL4

Bits	Bit Name	Settings	Description	Reset	Access
7	RESERVED		Reserved.	0x0	R/W
6	RESERVED		Reserved.	0x0	R/W
5	RESERVED		Reserved.	0x0	R/W

Bits	Bit Name	Settings	Description	Reset	Access
4	LRCLK_DRV	0 1	Drive strength control. Low drive strength. High drive strength.	0x0	R/W
3	BCLK_DRV	0 1	Drive strength control. Low drive strength. High drive strength.	0x0	R/W
2	ADC_SDATA1_DRV	0 1	Drive strength control. Low drive strength. High drive strength.	0x0	R/W
1	ADC_SDATA0_DRV	0 1	Drive strength control. Low drive strength. High drive strength.	0x0	R/W
0	RESERVED		Reserved.	0x0	R/W

DIGITAL PIN DRIVE STRENGTH CONTROL 1 REGISTER

Address: 0x4D, Reset: 0x00, Name: PAD_CONTROL5

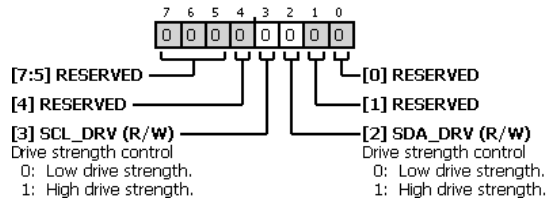

Table 112. Bit Descriptions for PAD_CONTROL5

Bits	Bit Name	Settings	Description	Reset	Access
[7:5]	RESERVED		Reserved.	0x0	R/W
4	RESERVED		Reserved.	0x0	R/W
3	SCL_DRV	0 1	Drive strength control. Low drive strength. High drive strength.	0x0	R/W
2	SDA_DRV	0 1	Drive strength control. Low drive strength. High drive strength.	0x0	R/W
1	RESERVED		Reserved.	0x0	R/W
0	RESERVED		Reserved.	0x0	R/W

FAST RATE CONTROL REGISTER

Address: 0x4E, Reset: 0x00, Name: FAST_RATE

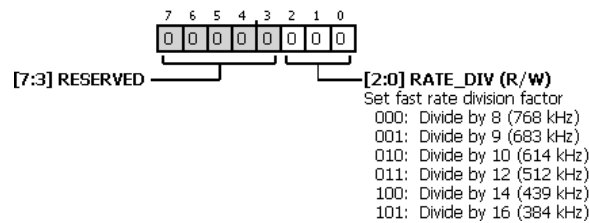

Table 113. Bit Descriptions for FAST_RATE

Bits	Bit Name	Settings	Description	Reset	Access
[7:3]	RESERVED		Reserved.	0x0	R/W
[2:0]	RATE_DIV	000 001 010 011 100 101	Set fast rate division factor. This factor is used to divide the internal master clock (6.144 MHz) when CORE_FS = 11. Do not change this setting while the core is running. CORE_RUN must be set to 0 for this setting to be updated. Divide by 8 (768 kHz). Divide by 9 (683 kHz). Divide by 10 (614 kHz). Divide by 12 (512 kHz). Divide by 14 (439 kHz). Divide by 16 (384 kHz).	0x0	R/W

DAC INTERPOLATION CONTROL REGISTER

Address: 0x4F, Reset: 0x00, Name: DAC_CONTROL0

The lowest interpolator latency is achieved with a zero-order hold (ZOH) selection. ZOH can be used for both 768 kHz and 192 kHz data. For 96 kHz data, use the linear interpolation to attain the lowest latency.

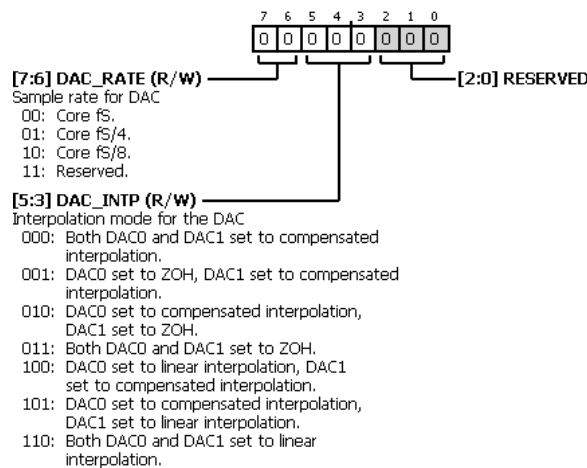

Table 114. Bit Descriptions for DAC_CONTROL0

Bits	Bit Name	Settings	Description	Reset	Access
[7:6]	DAC_RATE	00 01 10 11	Sample rate for DAC. Core f _s . Core f _s /4. Core f _s /8. Reserved.	0x0	R/W
[5:3]	DAC_INTP	000 001 010 011 100 101 110	Interpolation mode for the DAC. Both DAC0 and DAC1 set to compensated interpolation. DAC0 set to ZOH, DAC1 set to compensated interpolation. DAC0 set to compensated interpolation, DAC1 set to ZOH. Both DAC0 and DAC1 set to ZOH. DAC0 set to linear interpolation, DAC1 set to compensated interpolation. DAC0 set to compensated interpolation, DAC1 set to linear interpolation. Both DAC0 and DAC1 set to linear interpolation.	0x0	R/W

Bits	Bit Name	Settings	Description	Reset	Access
[2:0]	RESERVED		Reserved.	0x0	R/W

VOLUME CONTROL BYPASS REGISTER

Address: 0x54, Reset: 0x00, Name: VOL_BYPASS

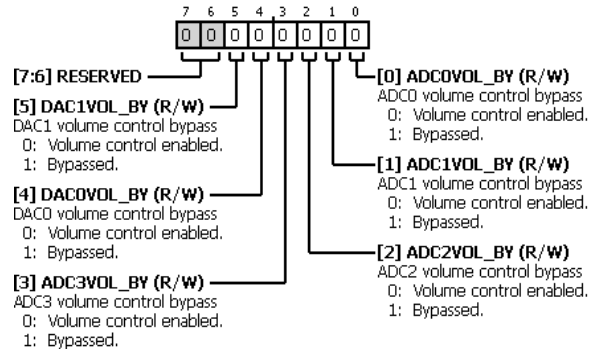

Table 115. Bit Descriptions for VOL_BYPASS

Bits	Bit Name	Settings	Description	Reset	Access
[7:6]	RESERVED		Reserved.	0x0	R/W
5	DAC1VOL_BY	0 1	DAC1 volume control bypass. Volume control enabled. Bypassed.	0x0	R/W
4	DAC0VOL_BY	0 1	DAC0 volume control bypass. Volume control enabled. Bypassed.	0x0	R/W
3	ADC3VOL_BY	0 1	ADC3 volume control bypass. Volume control enabled. Bypassed.	0x0	R/W
2	ADC2VOL_BY	0 1	ADC2 volume control bypass. Volume control enabled. Bypassed.	0x0	R/W
1	ADC1VOL_BY	0 1	ADC1 volume control bypass. Volume control enabled. Bypassed.	0x0	R/W
0	ADC0VOL_BY	0 1	ADC0 volume control bypass. Volume control enabled. Bypassed.	0x0	R/W

OUTLINE DIMENSIONS

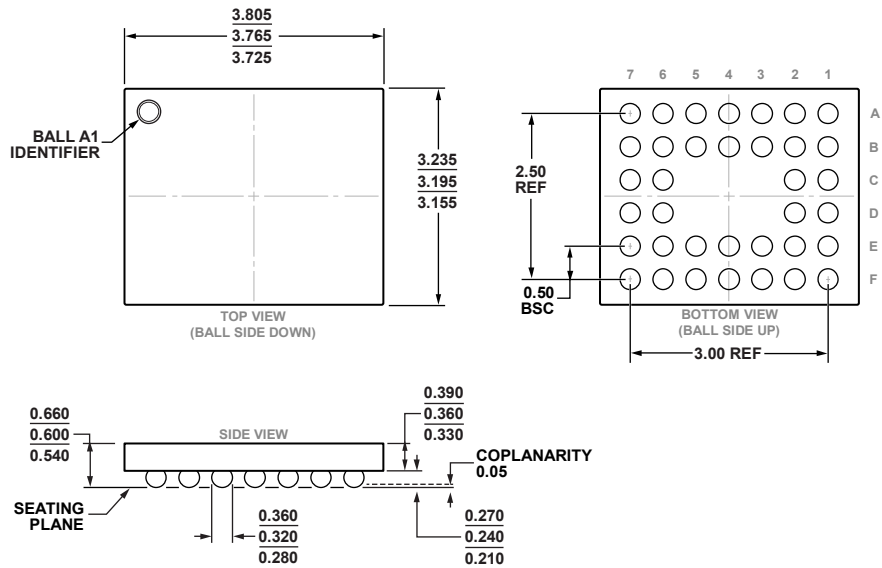

Figure 79. 36-Ball Wafer Level Chip Scale Package [WLCSP] (CB-36-4)
Dimension shown in millimeters

ORDERING GUIDE

Model ¹	Temperature Range	Package Description	Package Option
ADAU1777BCBZRL	-40°C to +85°C	36-Ball Wafer Level Chip Scale Package [WLCSP], 13" Tape and Reel	CB-36-4
EVAL-ADAU1777Z		Evaluation Board	

¹ Z = RoHS Compliant Part.

I²C refers to a communications protocol originally developed by Philips Semiconductors (now NXP Semiconductors).

Looking for pricing, stock, or lifecycle information?

Click below to explore more details on WIN SOURCE:

⊖ [View ADAU1777BCBZRL on WIN SOURCE](#)

⊖ [Analog Devices Inc. Information](#)

Optimize Your Supply Chain with WIN SOURCE Solutions

- ✓ Global Sourcing Solution
- ✓ Obsolete Management
- ✓ Cost Control Management
- ✓ Shortage Management
- ✓ Alternative Solution
- ✓ Excess Inventory Management