



**THE DATASHEET OF  
ADA4433-1WBCPZ-R2**



## FEATURES

- Qualified for automotive applications
- Output overvoltage (short-to-battery) protection up to 18 V
- Short-to-battery output flag for wire diagnostics
- Output short-to-ground protection
- Fifth-order, low-pass video filter
  - 0.1 dB flatness to 3 MHz
  - 3 dB bandwidth of 10 MHz
  - 45 dB rejection at 27 MHz
- Ultralow power-down current: 13.5  $\mu$ A typical
- Low quiescent current
  - 7.6 mA typical (ADA4432-1)
  - 13.2 mA typical (ADA4433-1)
- Low supply voltage: 2.6 V to 3.6 V
- Small packaging
  - 8-lead, 3 mm  $\times$  3 mm LFCSP
  - 6-lead SOT-23 (ADA4432-1 only)
- Wide operating temperature range: -40°C to +125°C

## APPLICATIONS

- Automotive rearview cameras
- Automotive video electronic control units (ECUs)
- Surveillance video systems

## GENERAL DESCRIPTION

The ADA4432-1 (single-ended output) and ADA4433-1 (differential output) are fully integrated video reconstruction filters that combine overvoltage protection (short-to-battery [STB] protection) and short-to-ground (STG) protection on the outputs, with excellent video specifications and low power consumption. The combination of STB protection and robust ESD tolerance allows the ADA4432-1 and the ADA4433-1 to provide superior protection in the hostile automotive environment.

The ADA4432-1 is a single-ended input/single-ended output video filter capable of driving long back-terminated cables.

The ADA4433-1 is a fully differential video filter that can be used as a fully differential input to a differential output or as a single-ended input to a differential output, allowing it to easily connect to both differential and single-ended sources. It is capable of driving twisted pair or coaxial cable with minimal line attenuation. Differential signal processing reduces the effects of ground noise, which can plague ground referenced systems. The ADA4433-1 is ideal for differential signal processing (gain and filtering) throughout the signal chain, simplifying the conversion between single-ended and differential components.

Rev. E

[Document Feedback](#)

Information furnished by Analog Devices is believed to be accurate and reliable. However, no responsibility is assumed by Analog Devices for its use, nor for any infringements of patents or other rights of third parties that may result from its use. Specifications subject to change without notice. No license is granted by implication or otherwise under any patent or patent rights of Analog Devices. Trademarks and registered trademarks are the property of their respective owners.

## FUNCTIONAL BLOCK DIAGRAMS

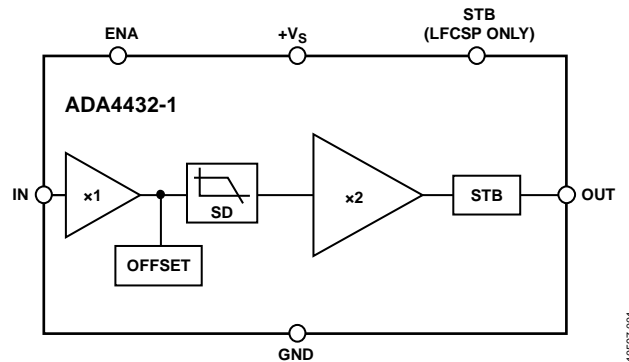

Figure 1.

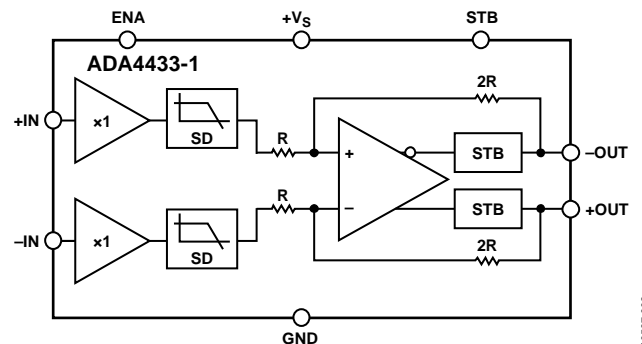

Figure 2.

The short-to-battery protection integrated into the ADA4432-1 and ADA4433-1 protects against both dc and transient overvoltage events, caused by an accidental short to a battery voltage up to 18 V. The Analog Devices, Inc., short-to-battery protection eliminates the need for large output coupling capacitors and other complicated circuits used to protect standard video amplifiers, saving space and cost.

The ADA4432-1 and ADA4433-1 feature a high-order filter with -3 dB cutoff frequency response at 10 MHz and 45 dB of rejection at 27 MHz. The ADA4432-1 and ADA4433-1 feature an internally fixed gain of 2 V/V. This makes the ADA4432-1 and ADA4433-1 ideal for SD video applications, including NTSC and PAL.

The ADA4432-1 and ADA4433-1 operate on single supplies as low as 2.6 V and as high as 3.6 V while providing the dynamic range required by the most demanding video systems.

The ADA4432-1 and ADA4433-1 are offered in an 8-lead, 3 mm  $\times$  3 mm LFCSP package. The ADA4432-1 is also available in a 6-lead SOT-23 package. All are rated for operation over the wide automotive temperature range of -40°C to +125°C.

## TABLE OF CONTENTS

Features ..... 1

Applications ..... 1

General Description ..... 1

Functional Block Diagrams ..... 1

Revision History ..... 2

Specifications ..... 3

    ADA4432-1 Specifications ..... 3

    ADA4433-1 Specifications ..... 4

Absolute Maximum Ratings ..... 6

    Thermal Resistance ..... 6

    Maximum Power Dissipation ..... 6

    ESD Caution ..... 6

Pin Configurations and Function Descriptions ..... 7

Typical Performance Characteristics ..... 9

    ADA4432-1 Typical Performance Characteristics ..... 9

    ADA4433-1 Typical Performance Characteristics ..... 12

Theory of Operation ..... 15

    Short Circuit (Short-to-Ground) Protection ..... 15

    Overvoltage (Short-to-Battery) Protection ..... 15

    Short-to-Battery Output Flag ..... 15

    ESD Protection ..... 16

    Enable/Disable Modes (ENA Pin) ..... 16

    Operating Supply Voltage Range ..... 16

Applications Information ..... 17

    Methods of Transmission ..... 17

    Printed Circuit Board (PCB) Layout ..... 17

    Configuring the ADA4433-1 for Single-Ended Input Signals ..... 18

    Pin-Compatible ADA4432-1 and ADA4433-1 ..... 19

    Typical Application Circuits ..... 20

    Fully DC-Coupled Transmission Line ..... 22

    Low Power Considerations ..... 23

Outline Dimensions ..... 24

    Ordering Guide ..... 25

    Automotive Products ..... 25

## REVISION HISTORY

### 5/2017—Rev. D to Rev. E

Changed CP-8-11 to CP-8-21 ..... Throughout

Deleted Figure 59; Renumbered Sequentially ..... 24

Changes to Figure 58 Caption ..... 24

### 8/2015—Rev. C to Rev. D

Updated Outline Dimensions ..... 24

Added Figure 59; Renumbered Sequentially ..... 24

Changes to Ordering Guide ..... 25

### 8/2014—Rev. B to Rev. C

Changes to Ordering Guide ..... 25

### 4/2014—Rev. A to Rev. B

Change to Theory of Operation Section ..... 15

Updated Outline Dimensions ..... 24

Changes to Ordering Guide ..... 25

### 5/2012—Rev. 0 to Rev. A

Added ADA4432-1 and 6-Lead SOT-23 ..... Universal

Added Figure 1; Renumbered Sequentially ..... 1

Added Table 1; Renumbered Sequentially ..... 3

Changes to Table 2 ..... 4

Added Figure 4, Figure 5, Table 5, and Table 6 ..... 7

Added Figure 7 to Figure 24 ..... 9

Changes to Operating Supply Voltage Range Section ..... 16

Added Methods of Transmission Section, Pseudo Differential Mode (Unbalanced Source Termination) Section, Figure 43, Pseudo Differential Mode (Balanced Source Impedance) Section and Figure 44 ..... 17

Changed Fully Differential Transmission Mode Section to Fully Differential Mode Section ..... 17

Added Pin-Compatible ADA4432-1 and ADA4433-1 Section, Example Configuration for Package-Compatible PCB Section, and Figure 48 to Figure 51 ..... 19

Added Figure 52 ..... 20

Added Figure 54 ..... 22

Added Low Power Consideration, Figure 56, and Figure 57 ... 23

Updated Outline Dimensions ..... 24

Changes to Ordering Guide ..... 25

### 4/2012—Revision 0: Initial Version

## SPECIFICATIONS

## ADA4432-1 SPECIFICATIONS

$T_A = 25^\circ\text{C}$ ,  $+V_S = 3.3\text{ V}$ ,  $R_L = 150\ \Omega$ , unless otherwise specified.

Table 1.

Parameter	Test Conditions/Comments	Min	Typ	Max	Unit
<b>DYNAMIC PERFORMANCE</b>					
–3 dB Small Signal Bandwidth	$V_{OUT} = 0.2\text{ V p-p}$		10.5		MHz
–3 dB Large Signal Bandwidth	$V_{OUT} = 2\text{ V p-p}$	9.3	10.5		MHz
	ADA4432-1W only: $T_{MIN}$ to $T_{MAX}$	8.6			MHz
1 dB Flatness	$V_{OUT} = 2\text{ V p-p}$	8.3	9.4		MHz
	ADA4432-1W only: $T_{MIN}$ to $T_{MAX}$	7.6			MHz
0.1 dB Flatness	$V_{OUT} = 2\text{ V p-p}$		3.3		MHz
Out-of-Band Rejection	$f = 27\text{ MHz}$ , $V_{OUT} = 2\text{ V p-p}$	37	43		dB
	ADA4432-1W only: $T_{MIN}$ to $T_{MAX}$	35			dB
Differential Gain	Modulated 10-step ramp, sync tip at 0 V		0.38		%
Differential Phase	Modulated 10-step ramp, sync tip at 0 V		0.69		Degrees
Group Delay Variation	$f = 100\text{ kHz}$ to $5\text{ MHz}$		8		ns
Pass Band Gain		5.80	6	6.24	dB
	ADA4432-1W only: $T_{MIN}$ to $T_{MAX}$	5.57		6.44	dB
<b>NOISE/HARMONIC PERFORMANCE</b>					
Signal-to-Noise Ratio	100% white signal, $f = 100\text{ kHz}$ to $5\text{ MHz}$		70		dB
<b>INPUT CHARACTERISTICS</b>					
Input Voltage Range	Limited by the output voltage range	0 to 1.34	0 to 1.4	0 to 1.45	V
	ADA4432-1W only: $T_{MIN}$ to $T_{MAX}$	0 to 1.3		0 to 1.47	V
Input Resistance			>1.0		G $\Omega$
Input Capacitance			8		pF
Input Bias Current			35		pA
<b>OUTPUT CHARACTERISTICS</b>					
Output Offset Voltage	$V_{IN} = 0\text{ V}$		192	280	mV
	ADA4432-1W only: $T_{MIN}$ to $T_{MAX}$			300	mV
Output Voltage Swing	$R_L = 150\ \Omega$	0.28		$+V_S - 0.42$	V
	ADA4432-1W only: $T_{MIN}$ to $T_{MAX}$	0.30		$+V_S - 0.45$	V
Linear Output Current			$\pm 37$		mA
Short-Circuit Output Current			$\pm 50$		mA
<b>SHORT-TO-BATTERY</b>					
Overvoltage Protection Range		$+V_S$		18	V
	ADA4432-1W only: $T_{MIN}$ to $T_{MAX}$	$+V_S$		18	V
STB Output Trigger Threshold	Back termination = $75\ \Omega$	6.3	7.2	8.1	V
	ADA4432-1W only: $T_{MIN}$ to $T_{MAX}$	6.0		8.4	V
Disconnect Time	After the fault is applied		150		ns
Reconnect Time	After the fault is removed		300		ns
<b>POWER SUPPLY</b>					
Power Supply Range <sup>1</sup>		2.6		3.6	V
Quiescent Current	No input signal, no load		7.6	10	mA
	ADA4432-1W only: $T_{MIN}$ to $T_{MAX}$			13	mA
Quiescent Current, Disabled	$ENA = 0\text{ V}$		14	20	$\mu\text{A}$
	ADA4432-1W only: $T_{MIN}$ to $T_{MAX}$			25	$\mu\text{A}$
Quiescent Current, Short-to-Battery	Short-to-battery fault condition: $18\text{ V}$		4.6		mA
Quiescent Current, Short to Ground	Short on far end of output termination ( $75\ \Omega$ )		47		mA
PSRR	$\Delta +V_S$ RIPPLE = $\pm 0.3\text{ V}$ , $f = \text{dc}$		–63		dB
<b>ENABLE PIN</b>					
Input Leakage Current	$ENA = \text{high/low}$		+0.3/–14		$\mu\text{A}$

Parameter	Test Conditions/Comments	Min	Typ	Max	Unit
LOGIC OUTPUT/INPUT LEVELS					
STB V <sub>OH</sub>	V <sub>OUT</sub> ≥ 7.2 V (fault condition)		3.3		V
STB V <sub>OL</sub>	V <sub>OUT</sub> ≤ 3.1 V (normal operation)		0.02		mV
ENA V <sub>IH</sub>	Input voltage to enable device		≥2.4		V
ENA V <sub>IL</sub>	Input voltage to disable device		≤0.6		V
OPERATING TEMPERATURE RANGE		-40		+125	°C

<sup>1</sup> Recommended range for optimal performance. Exceeding this range is not recommended.

## ADA4433-1 SPECIFICATIONS

T<sub>A</sub> = 25°C, +V<sub>S</sub> = 3.3 V, V<sub>-IN</sub> = 0.5 V, R<sub>L</sub> = 150 Ω, unless otherwise specified.

Table 2.

Parameter	Test Conditions/Comments	Min	Typ	Max	Unit
DYNAMIC PERFORMANCE					
-3 dB Small Signal Bandwidth	V <sub>OUT</sub> = 0.2 V p-p		9.9		MHz
-3 dB Large Signal Bandwidth	V <sub>OUT</sub> = 2 V p-p	8.8	9.9		MHz
	ADA4433-1W only: T <sub>MIN</sub> to T <sub>MAX</sub>	8.2			MHz
1 dB Flatness	V <sub>OUT</sub> = 2 V p-p	7.7	8.7		MHz
	ADA4433-1W only: T <sub>MIN</sub> to T <sub>MAX</sub>	7.2			MHz
0.1 dB Flatness	V <sub>OUT</sub> = 2 V p-p		3		MHz
Out-of-Band Rejection	f = 27 MHz	41	45		dB
	ADA4433-1W only: T <sub>MIN</sub> to T <sub>MAX</sub>	39			dB
Differential Gain	Modulated 10-step ramp, sync tip at 0 V		0.5		%
Differential Phase	Modulated 10-step ramp, sync tip at 0 V		1.7		Degrees
Group Delay Variation	f = 100 kHz to 5 MHz		8		ns
Pass Band Gain		5.89	6	6.15	dB
	ADA4433-1W only: T <sub>MIN</sub> to T <sub>MAX</sub>	5.71		6.28	dB
NOISE/HARMONIC PERFORMANCE					
Signal-to-Noise Ratio	100% white signal, f = 100 kHz to 5 MHz		67		dB
INPUT CHARACTERISTICS					
Input Common-Mode Voltage Range		0 to 2.1	0 to 2.2	0 to 2.3	V
	ADA4433-1W only: T <sub>MIN</sub> to T <sub>MAX</sub>	0 to 2.0		0 to 2.5	V
Input Resistance	Differential		800		kΩ
	Common mode		400		kΩ
Input Capacitance	Common mode		1.8		pF
Input Bias Current			30		pA
CMRR	V <sub>-IN</sub> = V <sub>+IN</sub> = 0.1 V to 1.1 V		-55		dB
OUTPUT CHARACTERISTICS					
Output Offset Voltage	V <sub>+IN</sub> = V <sub>-IN</sub> = 0 V		1.65	1.9	V
	ADA4433-1W only: T <sub>MIN</sub> to T <sub>MAX</sub>			1.9	V
Output Voltage Swing	Each single-ended output, R <sub>L, dm</sub> = 150 Ω	0.54		+V <sub>S</sub> - 0.55	V
	ADA4433-1W only: T <sub>MIN</sub> to T <sub>MAX</sub>	0.6		+V <sub>S</sub> - 0.6	V
Linear Output Current			±29		mA
Short-Circuit Output Current			±60		mA
Output Balance Error	DC to f = 100 kHz, V <sub>IN</sub> = 0.5 V p-p		-50		dB
SHORT-TO-BATTERY					
Protection Range		+V <sub>S</sub>		18	V
	ADA4433-1W only: T <sub>MIN</sub> to T <sub>MAX</sub>	+V <sub>S</sub>		18	V
STB Output Trigger Threshold	Each output back termination = 37.5 Ω	5.0	5.4	5.7	V
	ADA4433-1W only: T <sub>MIN</sub> to T <sub>MAX</sub>	4.9		6.0	V
Disconnect Time	After the fault is applied		150		ns
Reconnect Time	After the fault is removed		300		ns

Parameter	Test Conditions/Comments	Min	Typ	Max	Unit
<b>POWER SUPPLY</b>					
Power Supply Range <sup>1</sup>		2.6		3.6	V
Quiescent Current	No input signal, no load ADA4433-1W only: T <sub>MIN</sub> to T <sub>MAX</sub>		13.2	18	mA
Quiescent Current, Disabled	ENA = 0V ADA4433-1W only: T <sub>MIN</sub> to T <sub>MAX</sub>		13.5	19 22	mA μA
Quiescent Current, Short-to-Battery	Short-to-battery fault condition: 18 V		18	30	mA
Quiescent Current, Short-to-Ground	Short on far end of output termination (37.5 Ω)		60		mA
PSRR	$\Delta+V_{S\text{ RIPPLE}} = \pm 0.3\text{ V}$ , f = dc		-80		dB
<b>ENABLE PIN</b>					
Input Leakage Current	ENA = high/low		+0.3/-14		μA
<b>LOGIC OUTPUT/INPUT LEVELS</b>					
STB V <sub>OH</sub>	V <sub>OUT</sub> ≥ 5.7 V (fault condition)		3.3		V
STB V <sub>OL</sub>	V <sub>OUT</sub> ≤ 3 V (normal operation)		0.02		V
ENA V <sub>IH</sub>	Input voltage to enable device		≥2.4		V
ENA V <sub>IL</sub>	Input voltage to disable device		≤0.6		V
<b>OPERATING TEMPERATURE RANGE</b>					
		-40		+125	°C

<sup>1</sup> Recommended range for optimal performance. Exceeding this range is not recommended.

## ABSOLUTE MAXIMUM RATINGS

Table 3.

Parameter	Rating
Supply Voltage	4 V
Output Common-Mode Voltage	22 V
Input Differential Voltage	+V <sub>S</sub>
Power Dissipation	See Figure 3
Storage Temperature Range	-65°C to +125°C
Operating Temperature Range	-40°C to +125°C
Lead Temperature (Soldering, 10 sec)	260°C
Junction Temperature	150°C

Stresses at or above those listed under Absolute Maximum Ratings may cause permanent damage to the product. This is a stress rating only; functional operation of the product at these or any other conditions above those indicated in the operational section of this specification is not implied. Operation beyond the maximum operating conditions for extended periods may affect product reliability.

### THERMAL RESISTANCE

$\theta_{JA}$  is specified for the device soldered to a high thermal conductivity 4-layer (2s2p) circuit board, as described in EIA/JESD 51-7.

Table 4.

Package Type	$\theta_{JA}$	$\theta_{JC}$	Unit
6-Lead SOT-23	170	Not applicable	°C/W
8-Lead LFCSP	50	5	°C/W

### MAXIMUM POWER DISSIPATION

The maximum safe power dissipation in the ADA4432-1 and ADA4433-1 packages are limited by the associated rise in junction temperature ( $T_J$ ) on the die. At approximately 150°C, which is the glass transition temperature, the plastic changes its properties. Exceeding a junction temperature of 150°C for an extended time can result in changes in the silicon devices, potentially causing failure.

The power dissipated in the package ( $P_D$ ) is the sum of the quiescent power dissipation and the power dissipated in the package due to the load drive for all outputs. The quiescent power is the voltage between the supply pins ( $V_S$ ) times the quiescent current ( $I_S$ ). The power dissipated due to the load drive depends on the particular application. For each output, the power due to load drive is calculated by multiplying the load current by the associated voltage drop across the device. The power dissipated due to the loads is equal to the sum of the power dissipations due to each individual load. RMS voltages and currents must be used in these calculations.

Airflow increases heat dissipation, effectively reducing  $\theta_{JA}$ . Figure 3 shows the maximum power dissipation in the package vs. the ambient temperature for the 6-lead SOT-23 (170°C/W) and the 8-lead LFCSP (50°C/W) on a JEDEC standard 4-layer board.  $\theta_{JA}$  values are approximate.

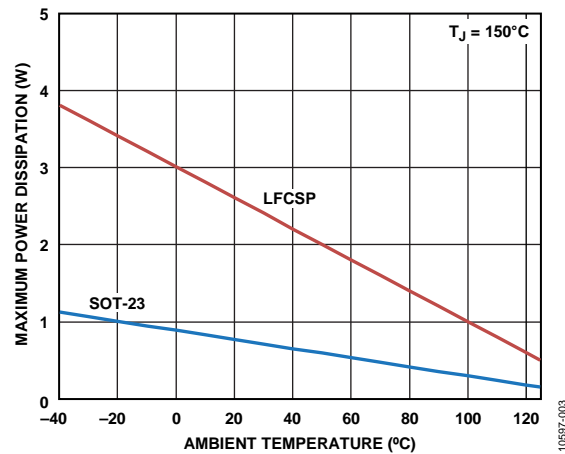

Figure 3. Maximum Power Dissipation vs. Ambient Temperature for a 4-Layer Board

### ESD CAUTION



**ESD (electrostatic discharge) sensitive device.** Charged devices and circuit boards can discharge without detection. Although this product features patented or proprietary protection circuitry, damage may occur on devices subjected to high energy ESD. Therefore, proper ESD precautions should be taken to avoid performance degradation or loss of functionality.

## PIN CONFIGURATIONS AND FUNCTION DESCRIPTIONS

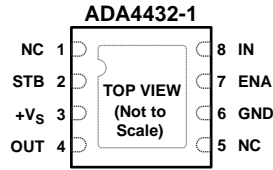

**NOTES**  
 1. NC = NO CONNECT.  
 2. THE EXPOSED PAD CAN BE CONNECTED TO THE GROUND PLANE.

10597-004

Figure 4. ADA4432-1 8-Lead LFCSP Pin Configuration, Top View

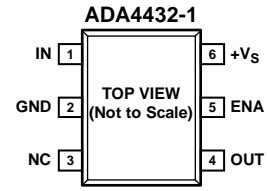

**NOTES:**  
 1. NC = NO CONNECT.

10597-005

Figure 5. ADA4432-1 6-Lead SOT-23 Pin Configuration, Top View

Table 5. ADA4432-1 8-Lead LFCSP Pin Function Descriptions

Pin No.	Mnemonic	Description
1	NC	No Connect. Do not connect to this pin.
2	STB	Short-to-Battery Indicator Output. A logic high indicates a short-to-battery condition, and a logic low indicates normal operation.
3	+Vs	Positive Power Supply. Bypass with 0.1 $\mu$ F capacitor to GND.
4	OUT	Amplifier Output.
5	NC	No Connect. Do not connect to this pin.
6	GND	Power Supply Ground Pin.
7	ENA	Enable Function. Connect to +Vs or float for normal operation; connect to GND for device disable.
8	IN EPAD	Input. The exposed pad can be connected to the ground plane.

Table 6. ADA4432-1 6-Lead SOT-23 Pin Function Descriptions

Pin No.	Mnemonic	Description
1	IN	Input.
2	GND	Power Supply Ground Pin.
3	NC	No Connect. Do not connect to this pin.
4	OUT	Amplifier Output.
5	ENA	Enable Function. Connect to +Vs or float for normal operation; connect to GND for device disable.
6	+Vs	Positive Power Supply. Bypass with 0.1 $\mu$ F capacitor to GND.

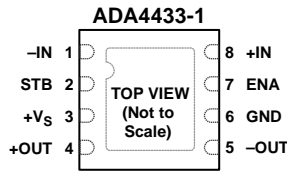

NOTES  
 1. THE EXPOSED PAD CAN BE CONNECTED TO THE GROUND PLANE.

10597-006

Figure 6. ADA4433-1 8-Lead LFCSP Pin Configuration, Top View

Table 7. ADA4433-1 8-Lead LFCSP Pin Function Descriptions

Pin No.	Mnemonic	Description
1	-IN	Inverting Input.
2	STB	Short-to-Battery Indicator Output. A logic high indicates a short-to-battery condition, and a logic low indicates normal operation.
3	+Vs	Positive Power Supply. Bypass with a 0.1 $\mu$ F capacitor to GND.
4	+OUT	Noninverting Output.
5	-OUT	Inverting Output.
6	GND	Ground.
7	ENA	Enable Function. Connect to +Vs or float for normal operation; connect to GND for device disable.
8	+IN	Noninverting Input.
	EPAD	The exposed pad can be connected to the ground plane.

# TYPICAL PERFORMANCE CHARACTERISTICS

## ADA4432-1 TYPICAL PERFORMANCE CHARACTERISTICS

$T_A = 25^\circ\text{C}$ ,  $+V_S = 3.3\text{ V}$ ,  $R_L = 150\ \Omega$ , unless otherwise specified.

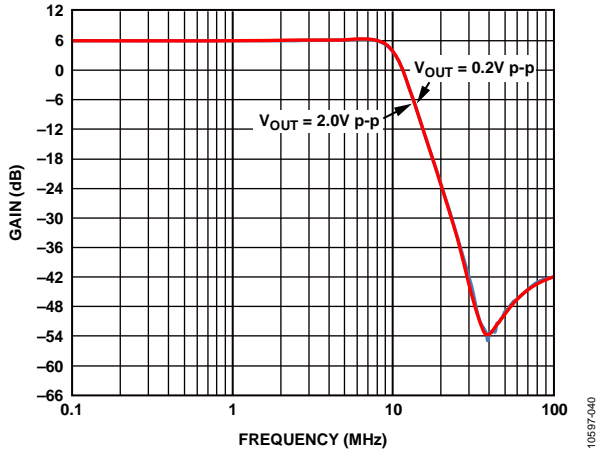

Figure 7. Frequency Response at Various Output Amplitudes

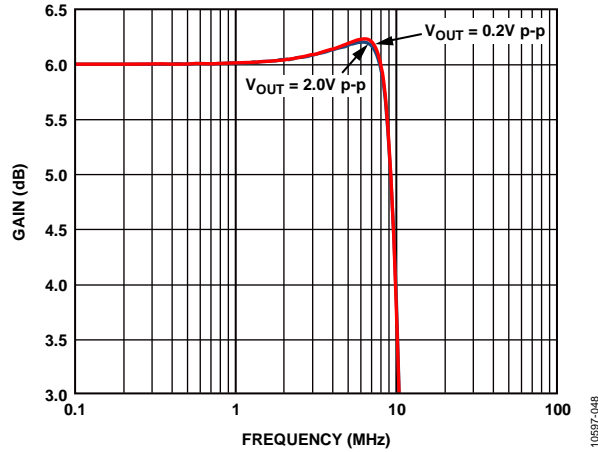

Figure 10. 1 dB Flatness Response at Various Output Amplitudes

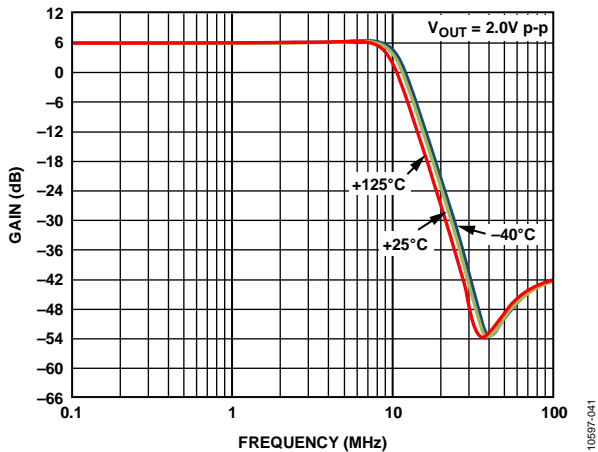

Figure 8. Large Signal Frequency Response at Various Temperatures

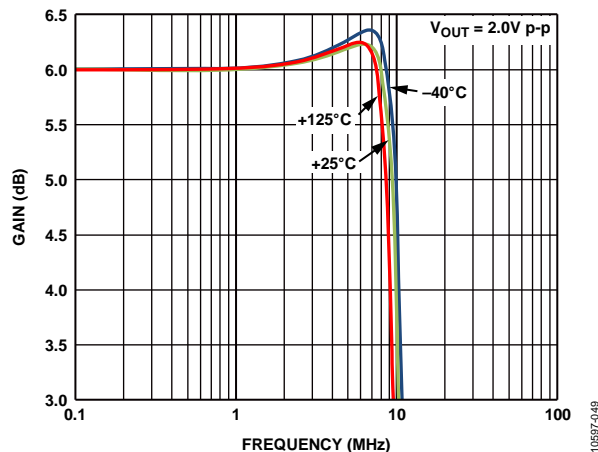

Figure 11. 1 dB Flatness Response at Various Temperatures

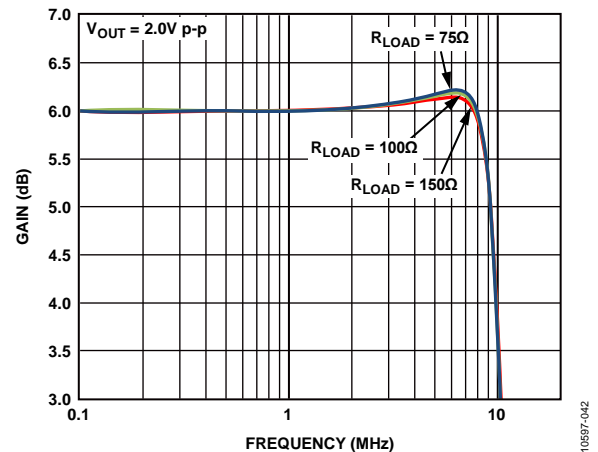

Figure 9. 1 dB Flatness Response at Various Load Resistances

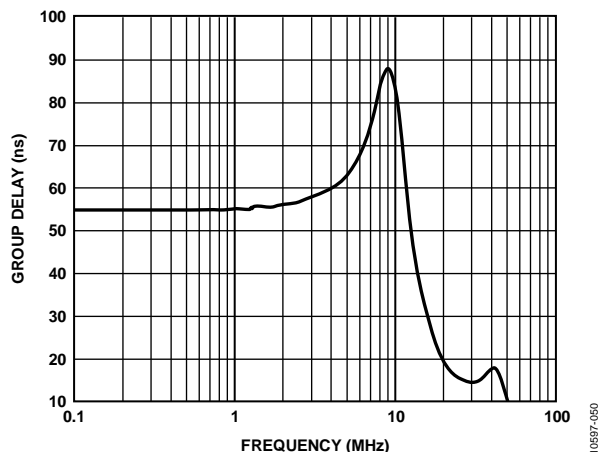

Figure 12. Group Delay vs. Frequency

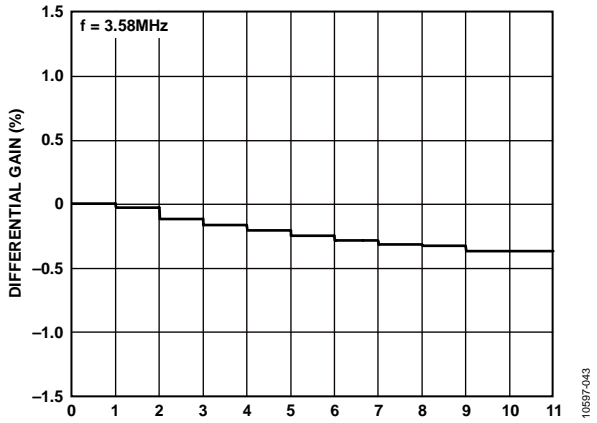

Figure 13. Differential Gain Plot

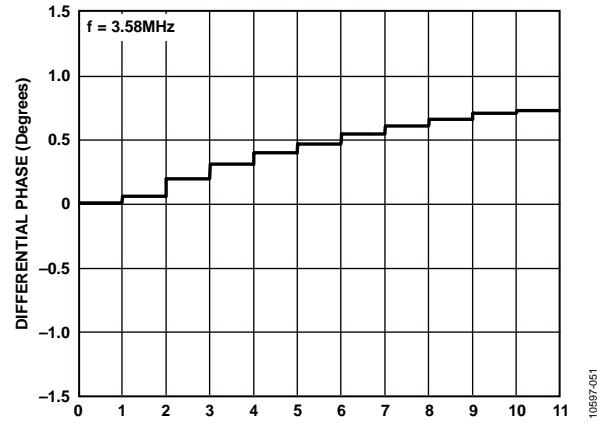

Figure 16. Differential Phase Plot

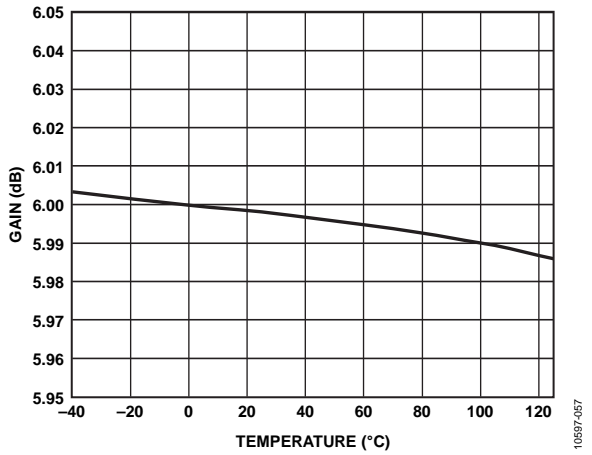

Figure 14. DC Pass Band Gain Drift (-40°C to +125°C)

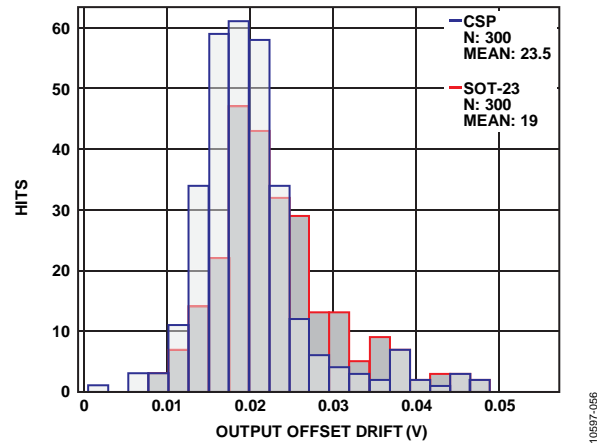

Figure 17. Total Output Offset Voltage Drift (-40°C to +125°C)

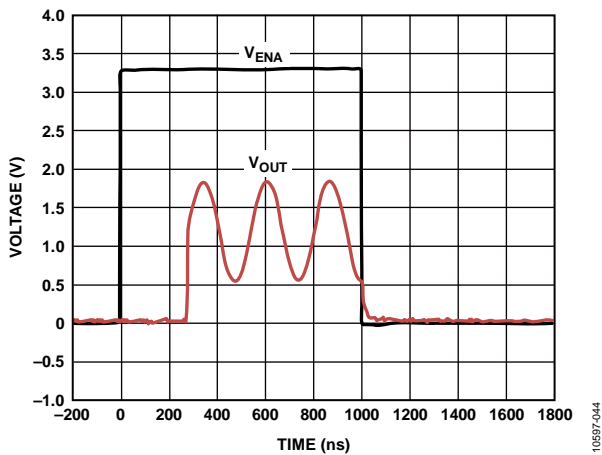

Figure 15. Enable (ENA)/Disable Time

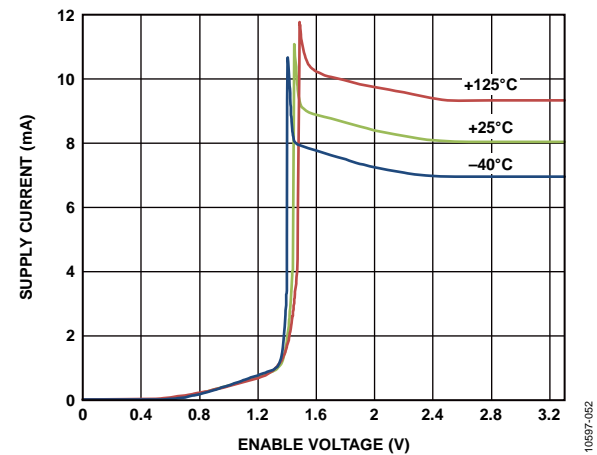

Figure 18. Supply Current vs. Enable Voltage at Various Temperatures

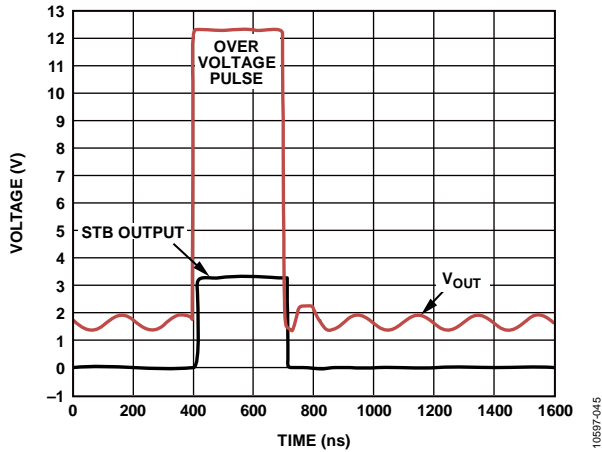

Figure 19. STB Output Flag Response Time

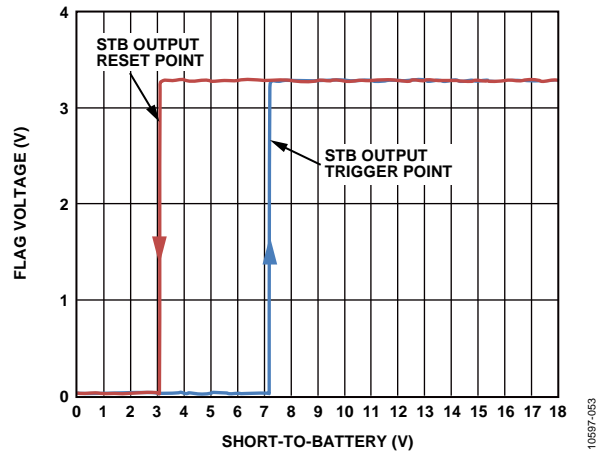

Figure 22. STB Output Response vs. Short-to-Battery Voltage on Outputs

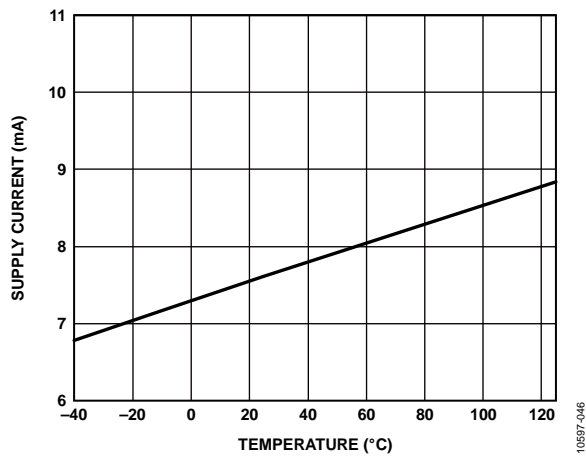

Figure 20. Supply Current vs. Temperature

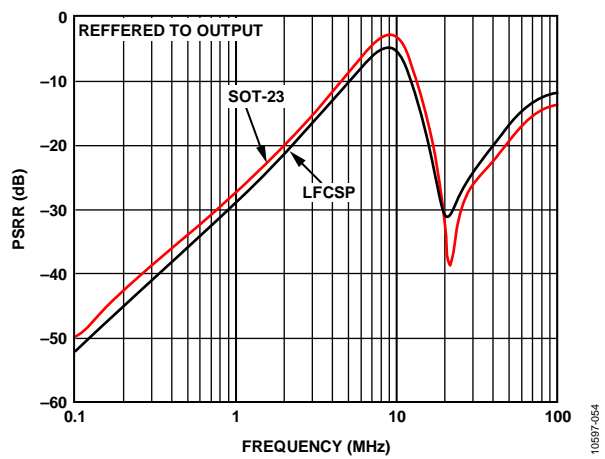

Figure 23. Power Supply Rejection Ratio (PSRR) vs. Frequency

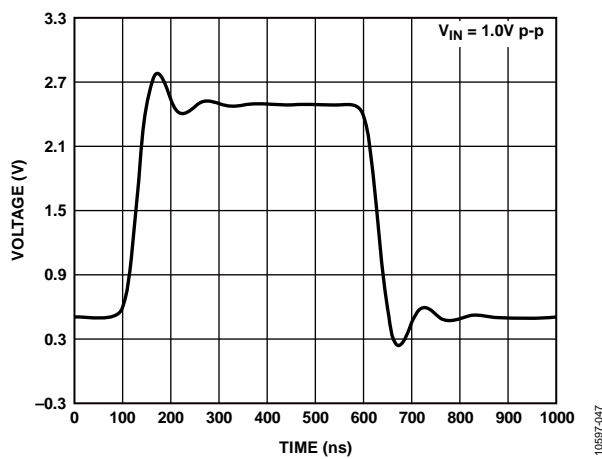

Figure 21. Output Transient Response

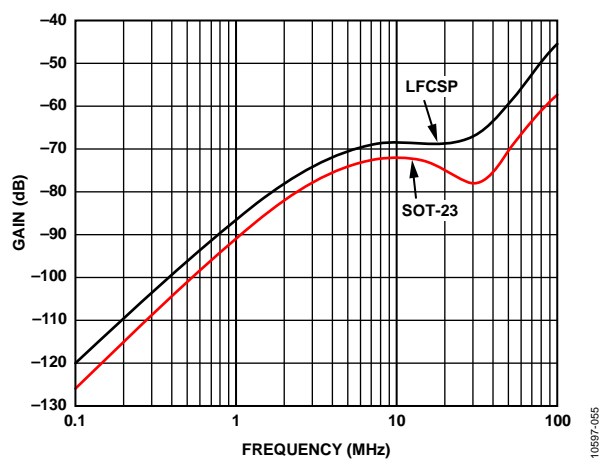

Figure 24. Input-to-Output Off (Disabled) Isolation vs. Frequency

**ADA4433-1 TYPICAL PERFORMANCE CHARACTERISTICS**

$T_A = 25^\circ\text{C}$ ,  $+V_S = 3.3\text{ V}$ ,  $V_{-IN} = 0.5\text{ V}$ ,  $R_L = 150\ \Omega$ , unless otherwise specified.

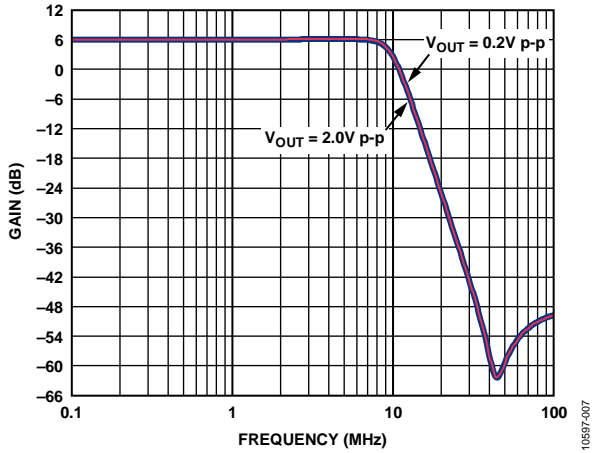

Figure 25. Frequency Response at Various Output Amplitudes

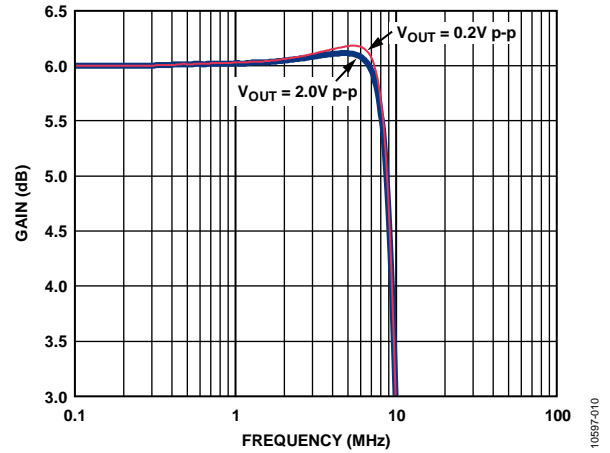

Figure 28. 1 dB Flatness Response at Various Output Amplitudes

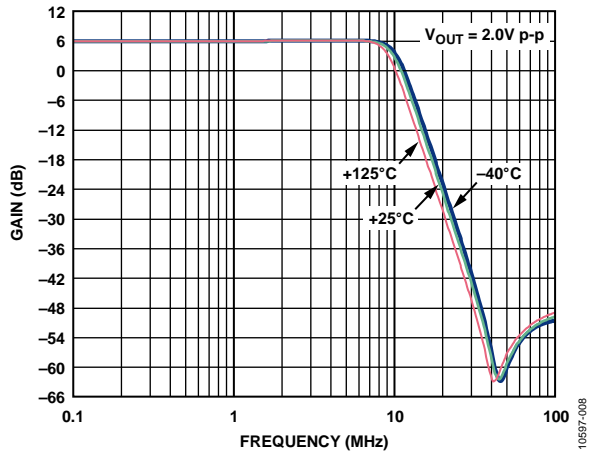

Figure 26. Large Signal Frequency Response at Various Temperatures

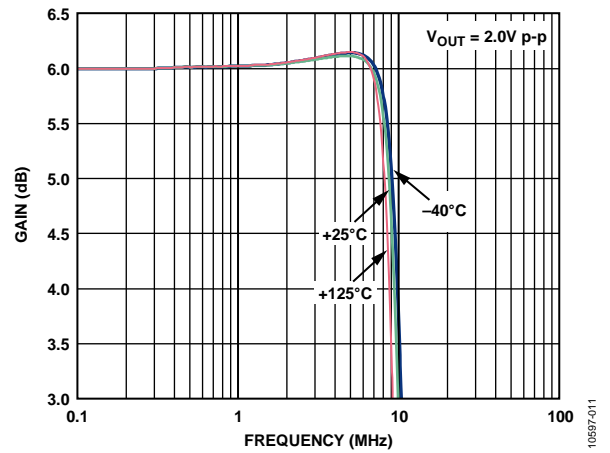

Figure 29. 1 dB Flatness Response at Various Temperatures

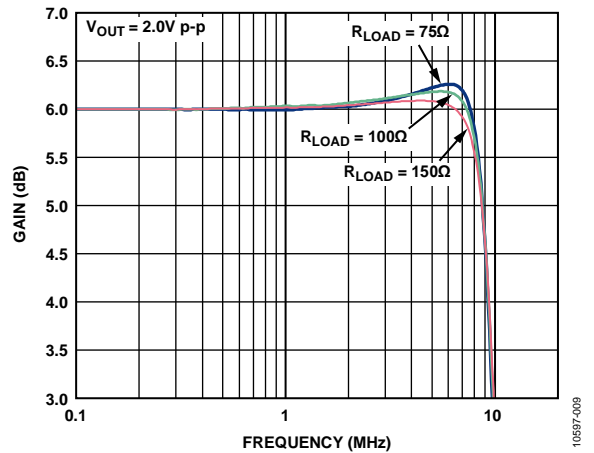

Figure 27. 1 dB Flatness Response at Various Load Resistances

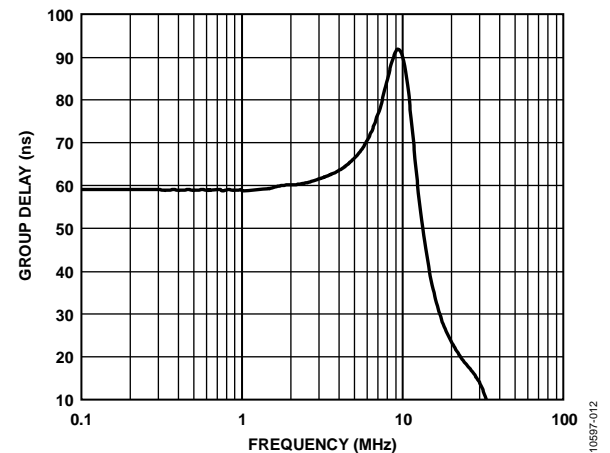

Figure 30. Group Delay vs. Frequency

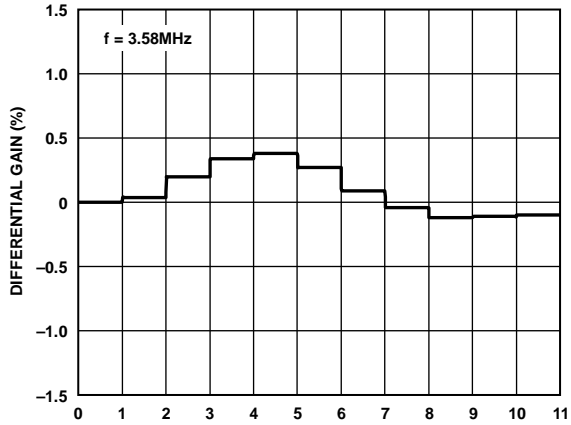

Figure 31. Differential Gain Plot

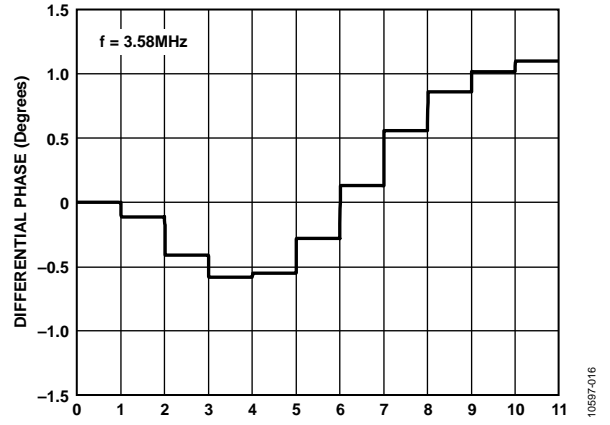

Figure 34. Differential Phase Plot

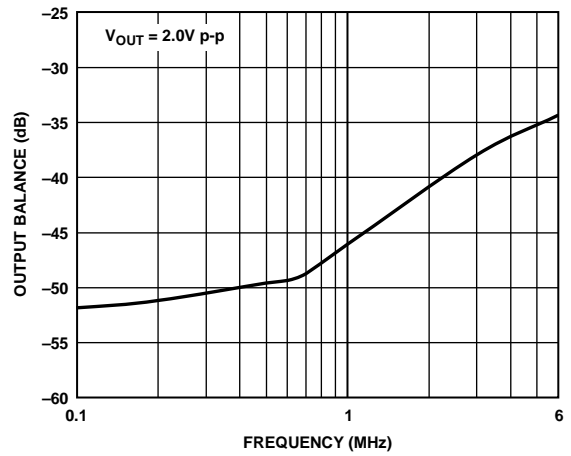

Figure 32. Output Balance Error vs. Frequency

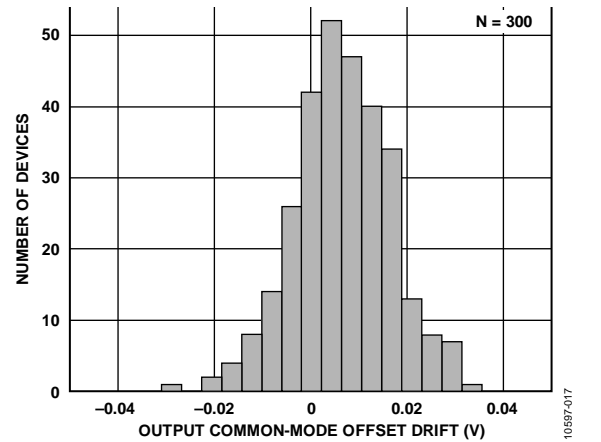

Figure 35. Total Output Common-Mode Offset Voltage Drift (-40°C to +125°C)

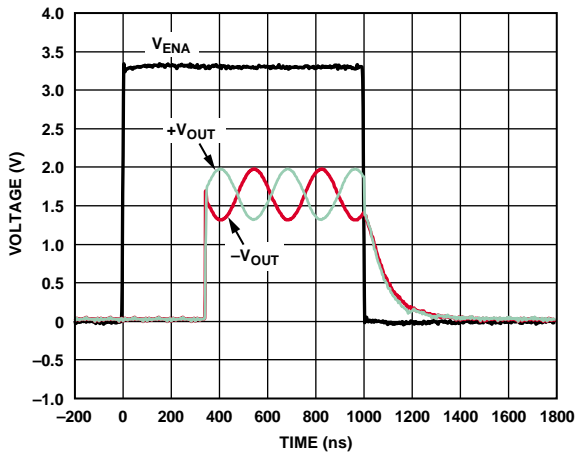

Figure 33. Enable (ENA)/Disable Time

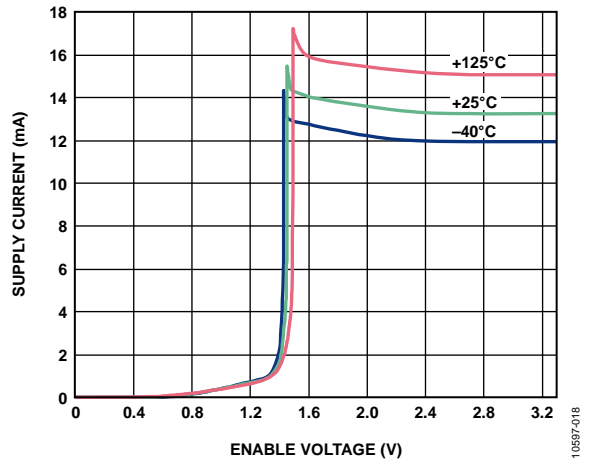

Figure 36. Supply Current vs. Enable Voltage at Various Temperatures

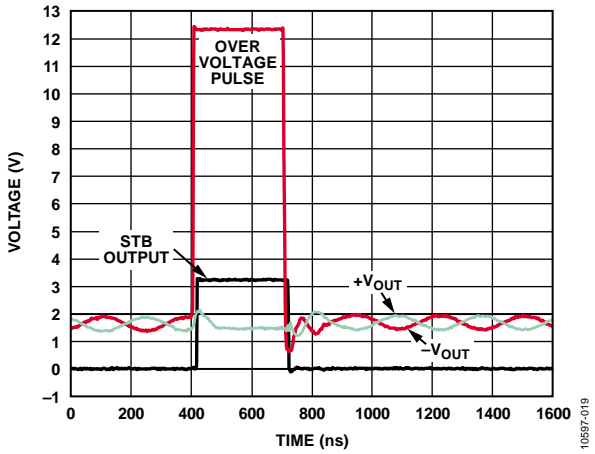

Figure 37. STB Output Flag Response Time

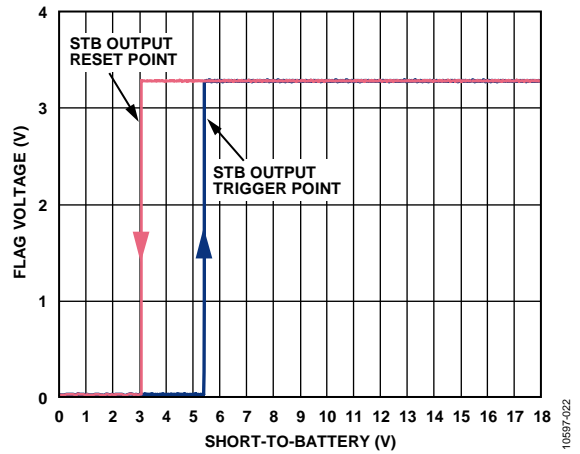

Figure 40. STB Output Response vs. Short-to-Battery Voltage on Outputs

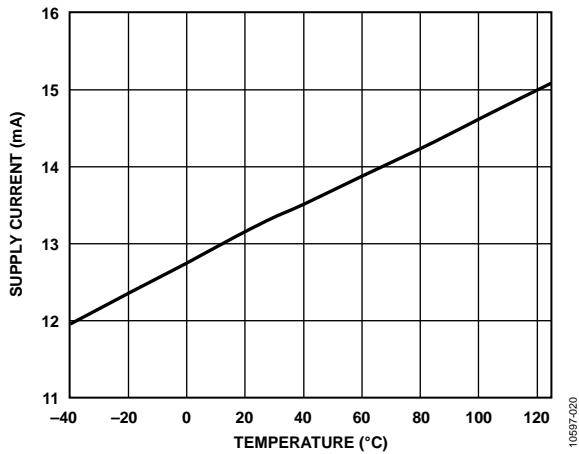

Figure 38. Supply Current vs. Temperature

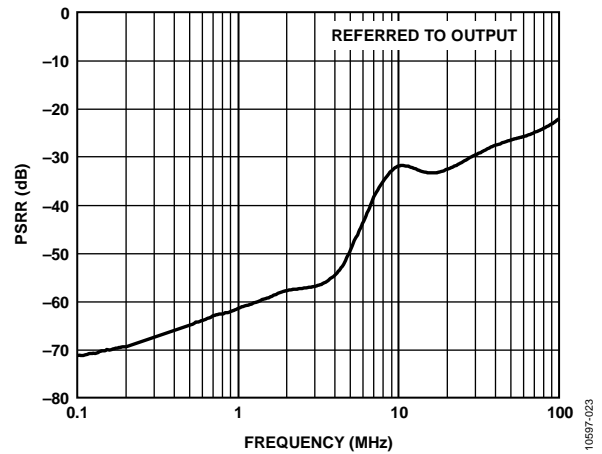

Figure 41. Power Supply Rejection Ratio (PSRR) vs. Frequency

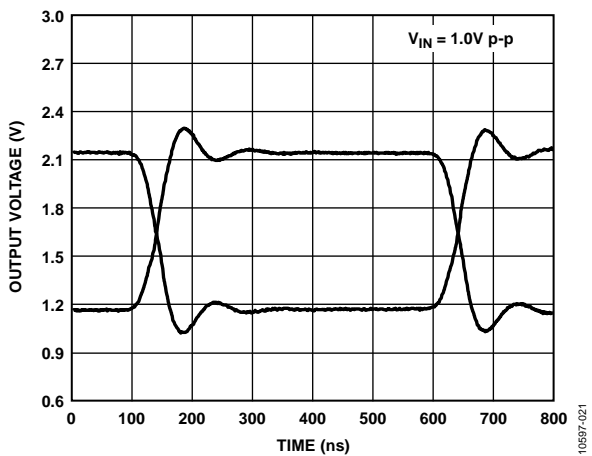

Figure 39. Output Transient Response

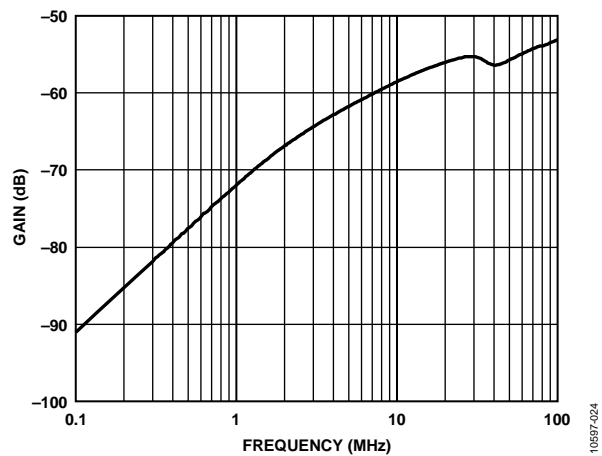

Figure 42. Input-to-Output Off (Disabled) Isolation vs. Frequency

## THEORY OF OPERATION

The [ADA4432-1](#) and [ADA4433-1](#) with short-to-battery and short-to-ground protection are designed as fifth-order, low-pass filters with a fixed gain of 2 that is capable of driving 2 V p-p video signals into doubly terminated video transmission lines on a single supply as low as 2.6 V. The filter has a 1 dB flatness of 9 MHz and provides a typical out-of-band rejection of 45 dB at 27 MHz.

The [ADA4432-1](#) is a single-ended filter/driver that can be used with both ac- and dc-coupled inputs and outputs, with an input range that includes ground for use with a ground referenced digital-to-analog converter (DAC) in a single-supply application. To ensure accurate reproduction of ground referenced signals without saturating the output devices, an internal offset is added to shift the output voltage up by 200 mV. For the ac-coupled input configuration, a dc bias network is needed at the input of the [ADA4432-1](#). This network can be implemented with a simple voltage divider between the ac-coupling capacitor and the input of the [ADA4432-1](#). It is important to remember to select R and C values appropriate for the frequencies of interest. The dc bias voltage set point must be well within the input voltage common-mode range of the [ADA4432-1](#), to accommodate the full amplitude of the input signal.

The [ADA4433-1](#) is a fully differential filter/driver that is also designed for compliance with both ac- and dc-coupled inputs and outputs. The [ADA4433-1](#) can be driven by a differential or single-ended source and provides a fully differential output signal that is biased at a voltage equal to half the supply voltage ( $+V_S/2$ ). When the device is used with a single-ended input source, bias the inverting input,  $-IN$ , at the middle of the input voltage range applied to the noninverting input,  $+IN$ , allowing each output signal to swing equally around the midsupply point (see the [Configuring the ADA4433-1 for Single-Ended Input Signals](#) section). This is particularly important to maximize output voltage headroom in low supply voltage applications.

### SHORT CIRCUIT (SHORT-TO-GROUND) PROTECTION

Both the [ADA4432-1](#) and [ADA4433-1](#) include internal protection circuits that limit the output sink or source current to 60 mA. This short circuit protection prevents damage to the [ADA4432-1](#) and [ADA4433-1](#) when the output(s) are shorted to ground, to a low impedance source, or together (in the case of the [ADA4433-1](#)) for an extended time. In addition, in the case of the [ADA4433-1](#), the total sink or source current for both outputs is limited to 50 mA, which helps protect the device in the event of both outputs being shorted to a low impedance. However, short circuit protection does not affect the normal operation of the devices because one output sources current, whereas the other output sinks current when driving a differential output signal.

### OVERVOLTAGE (SHORT-TO-BATTERY) PROTECTION

Both the [ADA4432-1](#) and [ADA4433-1](#) include internal protection circuits to ensure that internal circuitry is not subjected to extreme voltages or currents during an overvoltage event applied to their outputs. A short-to-battery condition usually

consists of a voltage on the outputs that is significantly higher than the power supply voltage of the amplifier. Duration can vary from a short transient to a continuous fault.

The [ADA4432-1](#) and [ADA4433-1](#) can withstand voltages of up to 18 V on the outputs. Critical internal nodes are protected from exposure to high voltages by circuitry that isolates the output devices from the high voltage and limits internal currents. This protection is available whether the device is enabled or disabled, even when the supply voltage is removed.

The output devices are disconnected when the voltage at the output pins exceeds the supply voltage. After the overvoltage condition is removed, internal circuitry pulls the output voltage back within normal operating levels. The output devices are reconnected when the voltage at the output pins falls below the supply voltage by about 300 mV. When the devices are used with a doubly terminated cable, the voltage sensed at the output pins is lower than the voltage applied to the cable by the voltage drop across the back termination resistor. The maximum voltage drop across the back termination resistor is limited by the short-circuit current protection; therefore, the threshold at which the overvoltage protection responds to a voltage applied to the cable is

$$V_{THRESH(CABLE)} = +V_S + I_{LIMIT}R_T$$

where:

$V_{THRESH(CABLE)}$  is the voltage applied to the cable that activates the internal isolation circuitry.

$+V_S$  is the positive supply voltage.

$I_{LIMIT}$  is the internal short-circuit current limit, typically 50 mA.

$R_T$  the back termination resistance.

If the voltage applied to the cable is lower than  $V_{THRESH(CABLE)}$ , the voltage seen at the output pins is lower than the supply voltage, so no overvoltage condition is detected. However, the internal circuitry is protected by the short circuit current limit; therefore, the [ADA4432-1/ADA4433-1](#) can withstand an indefinite duration short to any positive voltage up to 18 V without damage.

### SHORT-TO-BATTERY OUTPUT FLAG

In addition to the internal protection circuitry, the short-to-battery output flag (STB pin) indicates an overvoltage condition on either or both output pins. The flag is present whenever the internal overvoltage protection is active; therefore, it is available when the device is enabled or disabled. It is not available, however, when the supply voltage is removed, although the internal protection is still active. The threshold at which the short-to-battery flag is activated and deactivated is the same as the threshold for the protection circuitry.

Table 8. STB Pin Logic

STB Pin Output	Device State
High (Logic 1)	Overvoltage fault condition
Low (Logic 0)	Normal operation

**ESD PROTECTION**

All pins on the [ADA4432-1](#) and [ADA4433-1](#) are protected with internal ESD protection structures connected to the power supply pins (+V<sub>S</sub> and GND). These structures provide protection during the handling and manufacturing process.

The outputs (OUT for the [ADA4432-1](#) and +OUT and –OUT for the [ADA4433-1](#)) can be exposed to dc voltages well above the supply voltage in an overvoltage event; therefore, conventional ESD structure protection cannot be used. Instead, the outputs are protected by Analog Devices proprietary ESD devices, which allow protection and recovery from an overvoltage event while providing ESD protection well beyond the handling and manufacturing requirements.

The outputs of the [ADA4432-1](#) and [ADA4433-1](#) are ESD protected to survive ±8 kV and ±6 kV human body model (HBM), respectively.

**ENABLE/DISABLE MODES (ENA PIN)**

The power-down or enable/disable (ENA) pin is internally pulled up to +V<sub>S</sub> through a 250 kΩ resistor. When the voltage on this pin is high, the amplifier is enabled; pulling ENA low disables the [ADA4432-1](#) and [ADA4433-1](#), reducing the supply current

to a very low 13.5 μA. With no external connection, this pin floats high, enabling the amplifier.

**Table 9. ENA Pin Function**

ENA Pin Input	Device State
High (Logic 1)	Enabled
Low (Logic 0)	Disabled
High-Z (Floating)	Enabled

**OPERATING SUPPLY VOLTAGE RANGE**

The [ADA4432-1](#) and [ADA4433-1](#) are specified over an operating supply voltage range of 2.6 V to 3.6 V. This range establishes the nominal utilization voltage at which the devices perform in conformance with their specifications. The operating supply voltage refers to sustained voltage levels and not to a momentary voltage excursion that can occur due to variation in the output of the supply regulator. When the devices operate at the limits of the operating supply voltage range (2.6 V to 3.6 V), excursions that are outside of this range, but less than the absolute maximum, can lead to some performance degradation; however, they do not damage the device.

## APPLICATIONS INFORMATION

### METHODS OF TRANSMISSION

#### **Pseudo Differential Mode (Unbalanced Source Termination)**

The ADA4432-1 can be used as a pseudo differential driver with an unbalanced transmission line. Pseudo differential mode uses a single conductor to carry an unbalanced data signal from the driver to the receiver, while a second conductor is used as a ground reference signal.

The positive conductor connects the ADA4432-1 output to the positive input of a differential receiver, such as ADA4830-1. The negative wire or ground conductor from the source circuitry connects to the negative input of the receiver. Match the impedance of the input termination at the receiver to the output termination of the ADA4432-1 (see Figure 43).

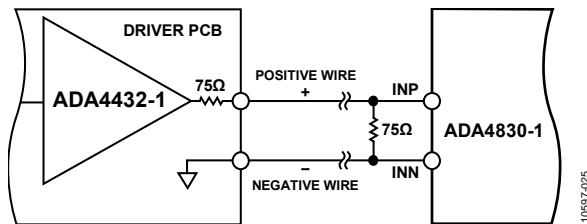

Figure 43. Pseudo Differential Mode

#### **Pseudo Differential Mode (Balanced Source Impedance)**

Pseudo differential signaling is typically implemented using unbalanced source termination, as shown in Figure 43. With this arrangement, however, common-mode signals on the positive and negative inputs receive different attenuation due to unbalanced termination at the source. This effectively converts some of the common-mode signal into a differential mode signal, degrading the overall common-mode rejection of the system. System common-mode rejection can be improved by balancing the output impedance of the driver, as shown in Figure 44. Splitting the source termination resistance evenly between the hot and cold conductors results in matched attenuation of the common-mode signals, ensuring maximum rejection.

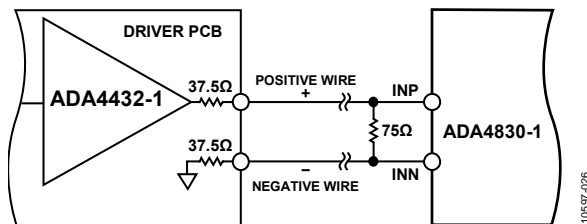

Figure 44. Pseudo Differential Mode with Balanced Source Impedance

#### **Fully Differential Mode**

The ADA4433-1 is designed to be used as a fully differential driver. The differential outputs of the ADA4433-1 allow fully balanced transmission using twisted or untwisted pair cable. In this configuration, the differential output termination consists of two source resistors, one on each output, and each equal to half the receiver input termination. For example, in a 75 Ω system, each output of the ADA4433-1 is back terminated with 37.5 Ω resistors that are connected to a differential resistance of 75 Ω at the receiver. An illustration of this arrangement is shown in Figure 45.

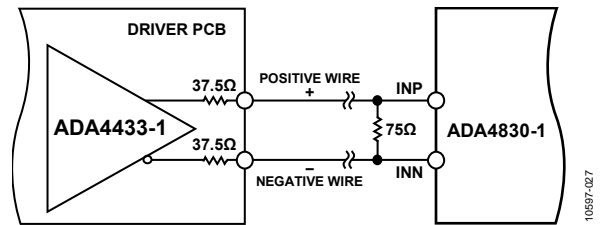

Figure 45. Fully Differential Mode

### PRINTED CIRCUIT BOARD (PCB) LAYOUT

As with all high speed applications, attention to PCB layout is of paramount importance. Adhere to standard high speed layout practices when designing with the ADA4432-1 and ADA4433-1. A solid ground plane is recommended. Place a 0.1 μF surface-mount, ceramic power supply decoupling capacitor as close as possible to the supply pin.

Connect the GND pin(s) to the ground plane with a trace that is as short as possible. Use controlled impedance traces of the shortest length possible to connect to the signal I/O pins and do not run the traces over any voids in the ground plane. A 75 Ω impedance level is typically used in video applications. All signal outputs of the ADA4432-1 and ADA4433-1 should include series termination resistors when driving transmission lines.

When the ADA4432-1 or the ADA4433-1 receives its inputs from a device with current outputs, the required load resistor value for the output current is most often different from the characteristic impedance of the signal traces. In this case, if the interconnections are sufficiently short (less than 2 inches), the trace does not need to be terminated in its characteristic impedance.

**CONFIGURING THE ADA4433-1 FOR SINGLE-ENDED INPUT SIGNALS**

The ADA4433-1 is a fully differential filter/driver that can be used as a single-ended-to-differential amplifier or as a differential-to-differential amplifier. In single-ended-to-differential output applications, bias the -IN input appropriately to optimize the output range. To make the most efficient use of the output range of the ADA4433-1, especially with low supply voltages, it is important to allow the differential output voltage to swing in both a positive and negative direction around the output common-mode voltage ( $V_{OCM}$ ) level, the midsupply point. To do this, the differential input voltage must swing both positive and negative. Figure 46 shows a 1 V p-p single-ended signal on +IN with -IN grounded. This produces a differential input voltage that ranges from 0 V to 1 V. The resulting differential output voltage is

strictly positive, where each output swings only above  $V_{+OUT}$  or below  $V_{-OUT}$ , the midsupply  $V_{OCM}$  level. Directly at the output of the ADA4433-1, the output voltage extends from 0.65 V to 2.65 V, requiring a full 2 V of output to produce a 1 V p-p signal at the receiver (represented by the voltage across 2R).

To make a more efficient use of the output range, the -IN input is biased at the midpoint of the expected input signal range, as shown in Figure 47. A 1 V p-p single-ended signal on +IN, with -IN biased at 0.5 V, produces a differential input voltage that ranges from -0.5 V to +0.5 V. The resulting differential output voltage now contains both positive and negative components, where each output swings both above and below the midsupply  $V_{OCM}$  level. Directly at the output of the ADA4433-1, the output voltage now extends only from 1.15 V to 2.15 V, requiring only 1 V of the output to produce a 1 V p-p signal at the receiver.

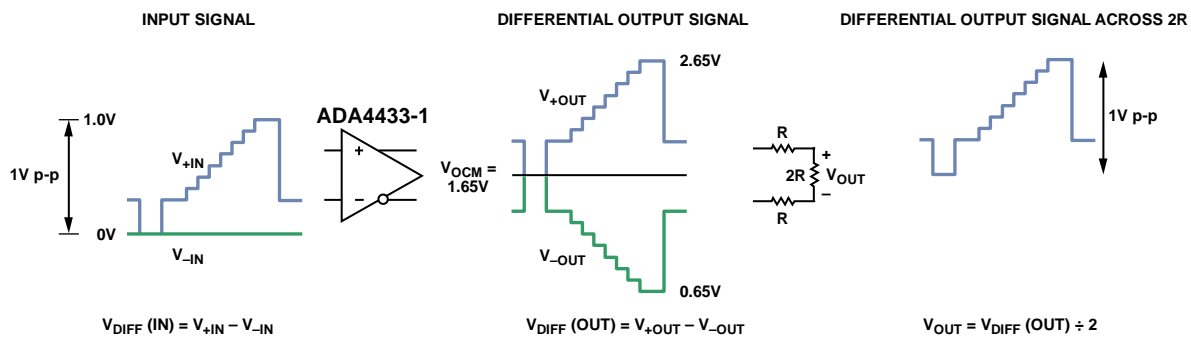

Figure 46. Single-Ended-to-Differential Configuration with Negative Input (-IN) Connected to Ground

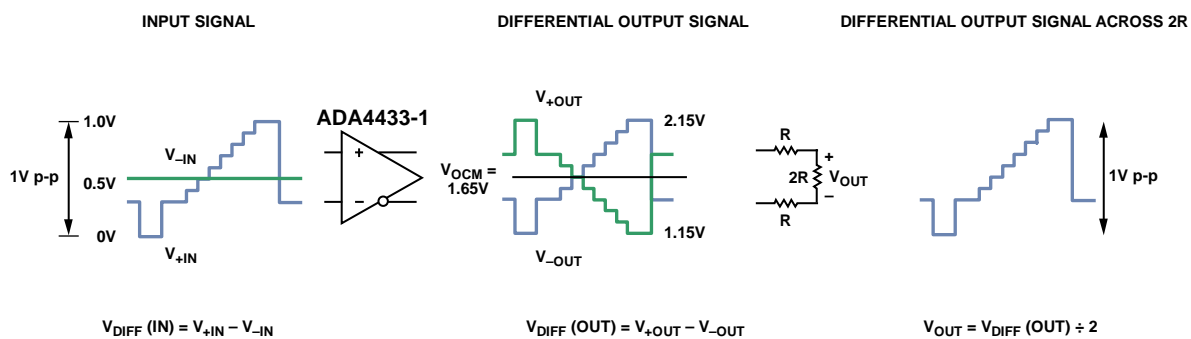

Figure 47. Single-Ended-to-Differential Configuration with Negative Input (-IN) Connected to 0.5 V

**PIN-COMPATIBLE ADA4432-1 AND ADA4433-1**

The ADA4432-1 and ADA4433-1 are single-ended output and differential output, respectively, short-to-battery protected video filters for automotive applications. Each version shares a common package, the 8-lead LFSCP, which allows them to share a common pinout and footprint. This allows a designer to change from a single-ended output configuration to a differential output on the same PCB with only minimal change to the external resistor values and placements. Figure 48 and Figure 50 show the pin configuration of the ADA4432-1 and ADA4433-1 in 8-lead LFSCP packages. Figure 49 and Figure 51 show an example schematic configured for the ADA4432-1 and the ADA4433-1, respectively.

**Example Configuration for Package-Compatible PCB**

The single-ended output with the ADA4432-1 includes the following:

- R1 matches the requirement for the source.
- R2, R3, and R6 are not installed.
- C3 is not installed.
- R5 is chosen to match the receiver termination impedance.
- R8 is 0 Ω to provide ground reference.

The differential output with the ADA4433-1 includes the following:

- R1 matches the requirement for the source.
- R2 and R3 are chosen to provide the correct bias for -IN.
- C3 is for the -IN bypass.
- R5 and R6 are chosen to match the receiver termination impedance.
- R8 is not installed.

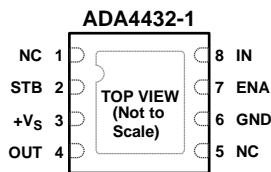

**NOTES**  
 1. NC = NO CONNECT.  
 2. THE EXPOSED PAD MAY BE CONNECTED TO THE GROUND PLANE.

10697-031

Figure 48. 8-Lead LFSCP Package Pin Configuration, ADA4432-1

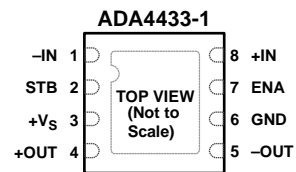

**NOTES**  
 1. THE EXPOSED PAD MAY BE CONNECTED TO THE GROUND PLANE.

10697-030

Figure 50. 8-Lead LFSCP Package Pin Configuration, ADA4433-1

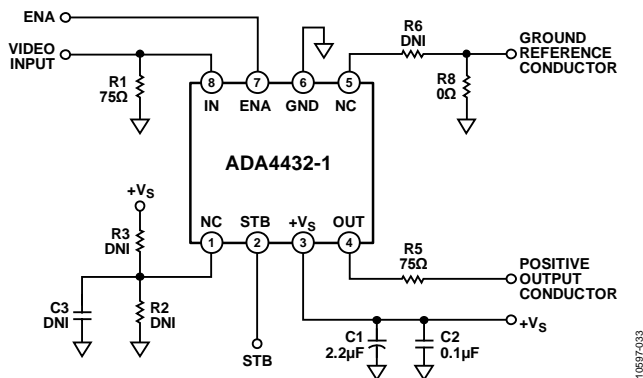

10697-033

Figure 49. Example Compatible Schematic Configured for the ADA4432-1

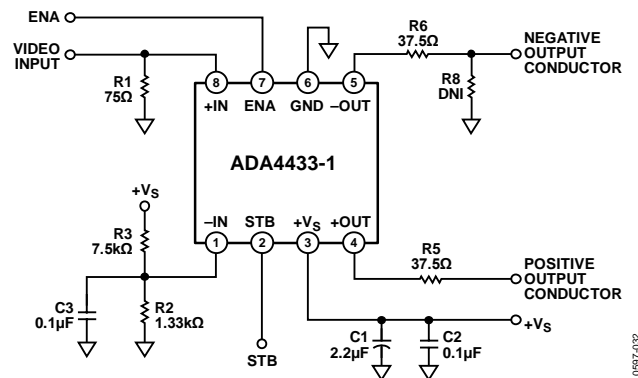

10697-032

Figure 51. Example Compatible Schematic Configured for the ADA4433-1

TYPICAL APPLICATION CIRCUITS

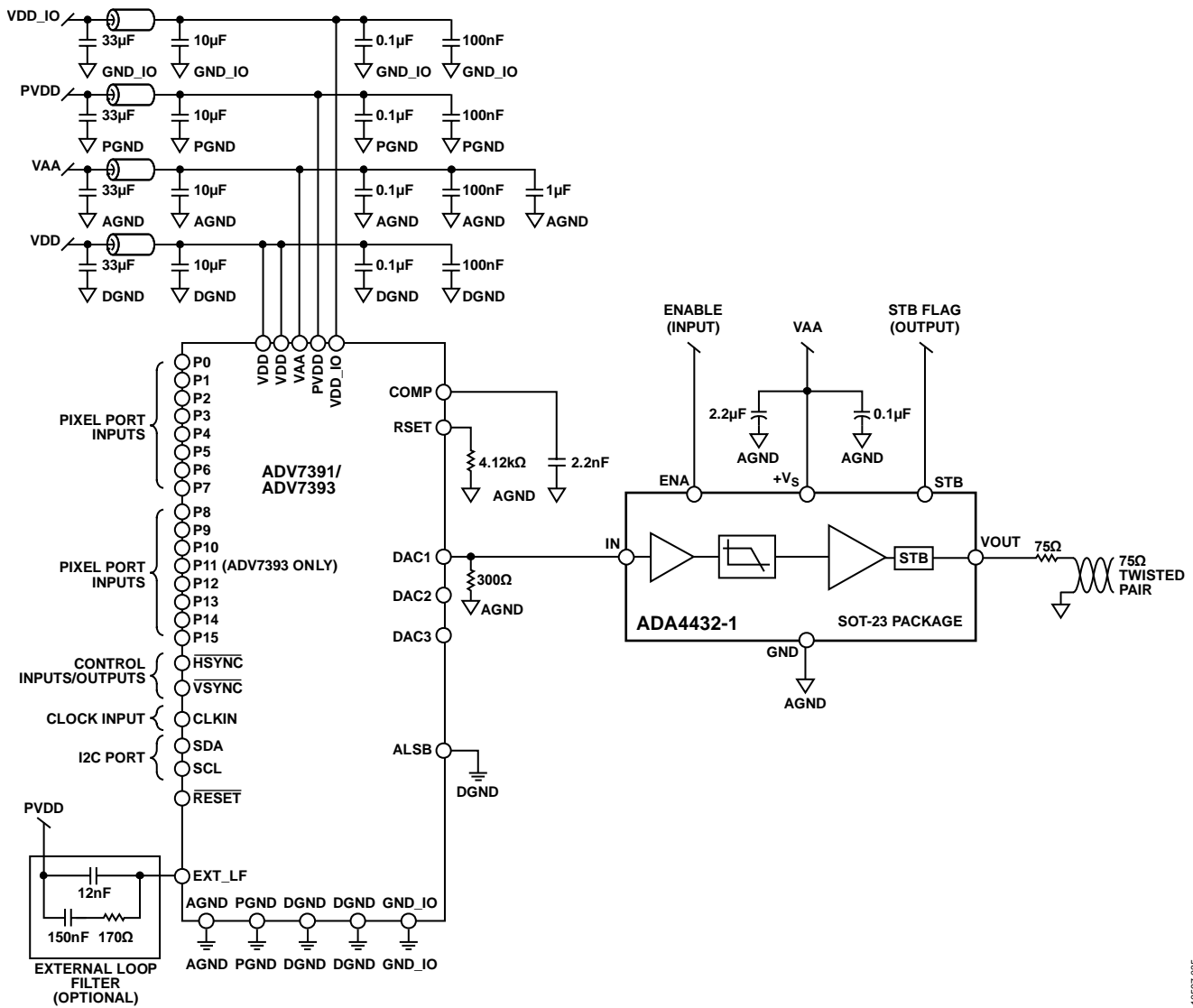

Figure 52. ADA4432-1 and ADV7391/ADV7393 Video Encoder Application Circuit

10697-035

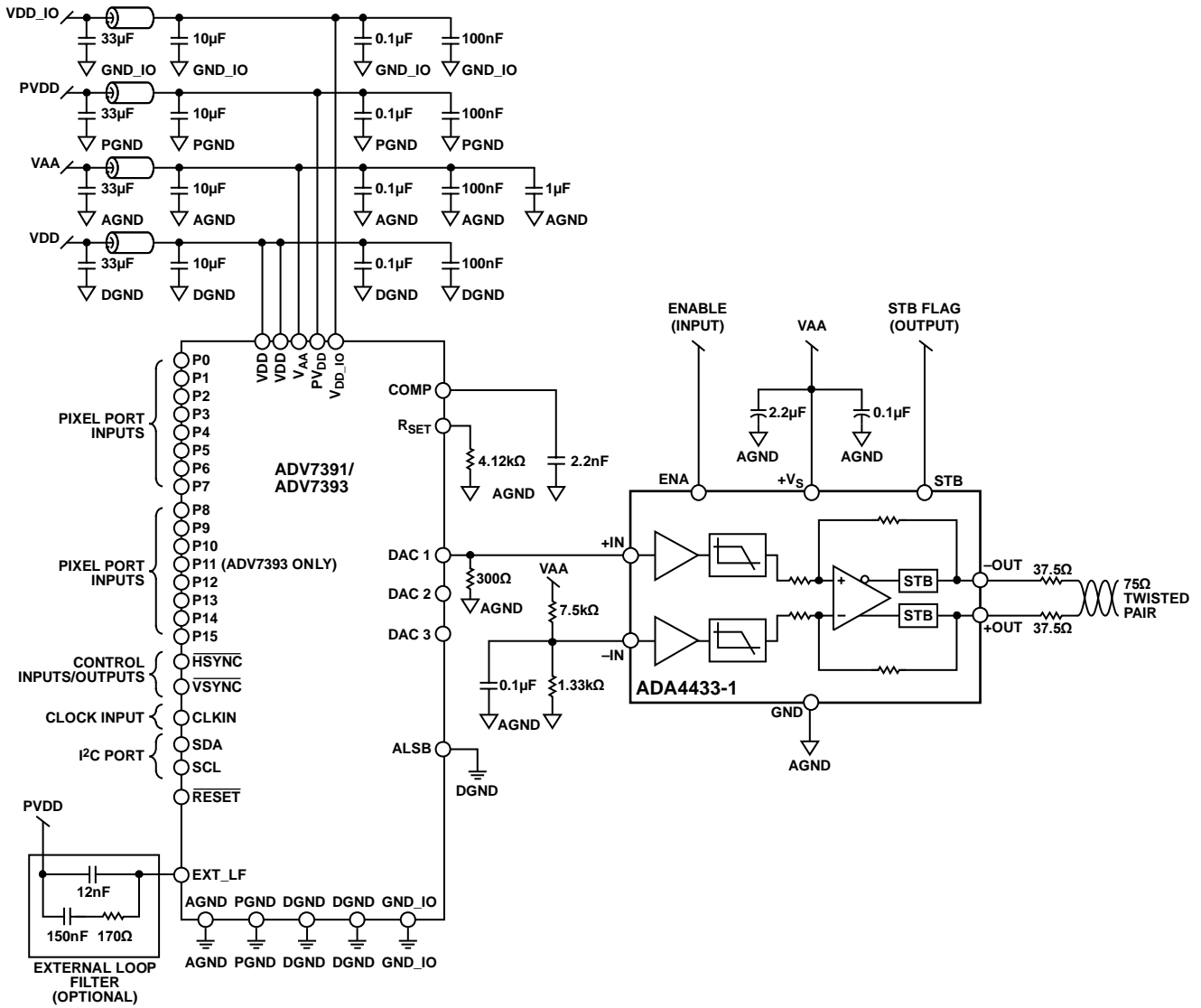

Figure 53. ADA4433-1 and ADV7391/ADV7393 Video Encoder Application Circuit

10697-1034

FULLY DC-COUPLED TRANSMISSION LINE

The ADA4432-1 and ADA4433-1 are designed to be used with high common-mode rejection, high input impedance receivers such as the ADA4830-1, ADA4830-2, or other generic receivers.

The very low output impedance of the ADA4432-1 and the ADA4433-1 allow them to be used in fully dc-coupled transmission line applications in which there may be a significant discrepancy between voltage levels at the ground pins of the driver and receiver. As long as the voltage difference between reference

levels at the transmitter and receiver is within the common-mode range of the receiver, very little current flow results, and no image degradation is anticipated.

Figure 54 and Figure 55 show an example configuration of a completely dc-coupled transmission using the ADA4432-1 and the ADA4433-1 along with a high input impedance differential receiver.

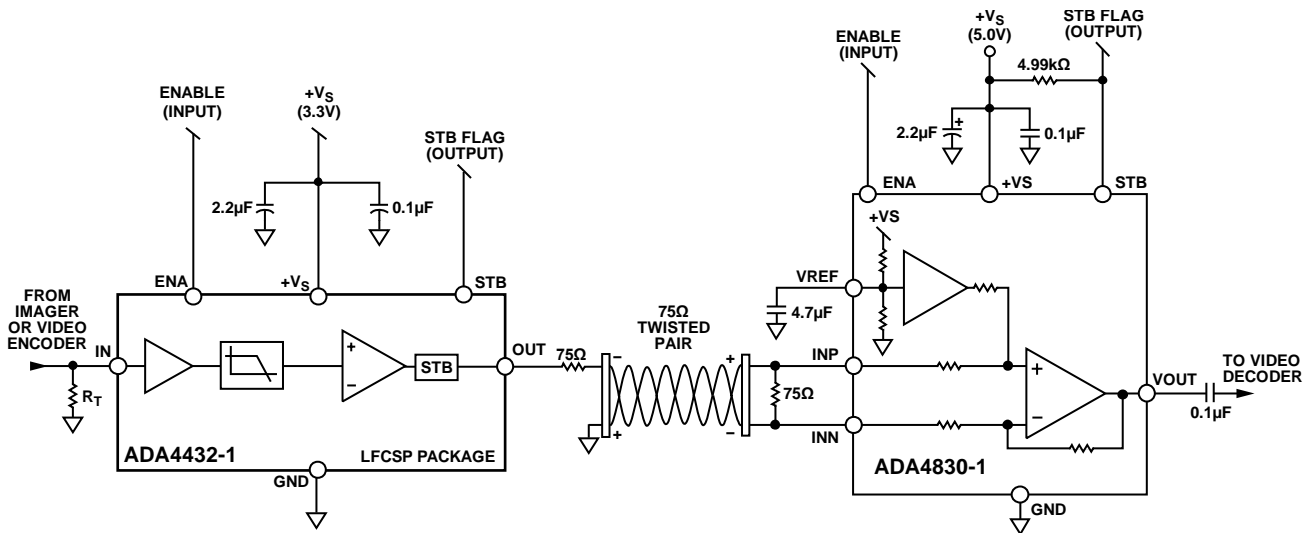

Figure 54. ADA4432-1 Video Filter and the ADA4830-1 Difference Amplifier in a DC-Coupled Configuration

10697-037

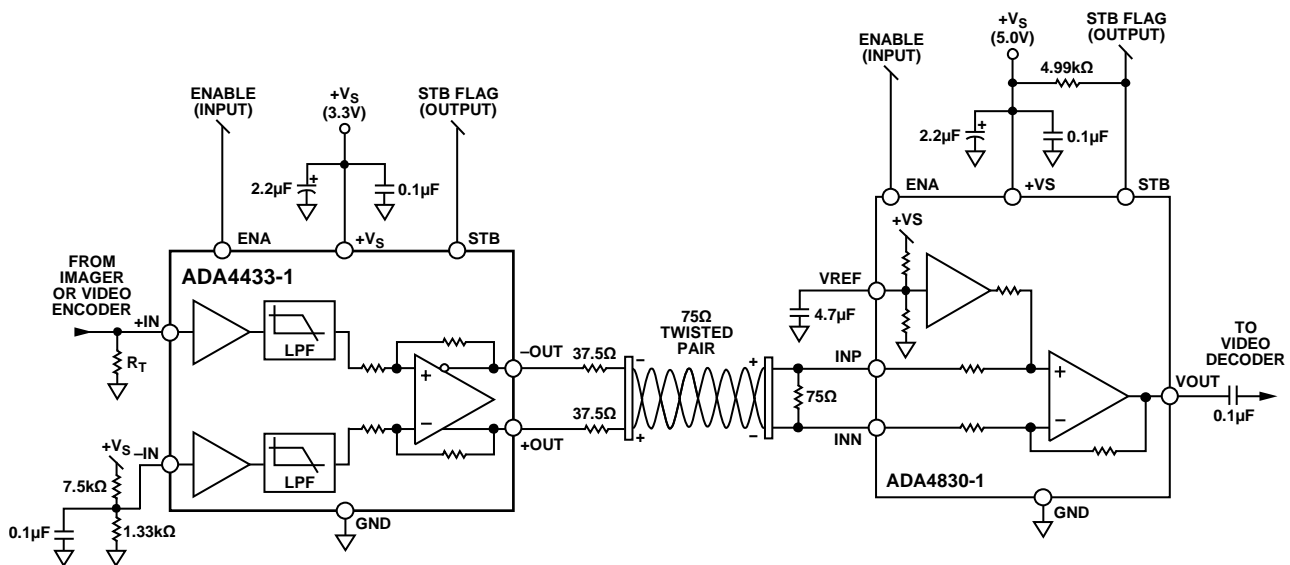

Figure 55. ADA4433-1 Video Filter and ADA4830-1 Difference Amplifier in a DC-Coupled Configuration

10697-036

## LOW POWER CONSIDERATIONS

Using a series source termination and a shunt load termination on a low supply voltage with the [ADA4432-1](#) or [ADA4433-1](#) realizes significant power savings compared with driving a video cable directly from a DAC output. Figure 56 shows a video DAC driving a cable directly. Properly terminated, a DAC driven transmission line requires two 75  $\Omega$  loads in parallel, demanding in excess of 33 mA to reach a full-scale voltage level of 1.3 V. Figure 57 shows the same video load being driven using the [ADA4432-1](#) and a series-shunt termination. This requires two times the output voltage to drive the equivalent of 150  $\Omega$  but only requires a little more than 15 mA to reach a full-scale output. When running on the same supply voltage as the DAC, this result in a 74% reduction in power consumption compared with the circuit in Figure 56. The high order filtering provided by the [ADA4432-1](#) lowers the requirements on the DAC oversampling ratio, realizing further power savings. The main source for power savings realized by the configuration shown in Figure 57 comes from the low drive mode setting for the [ADV7391](#). This along with the reduction in the requirement for oversampling (PLL turned off), and the reduced load current required, results in significant power savings.

For more detailed information on low drive mode, see the [ADV7391](#) data sheet.

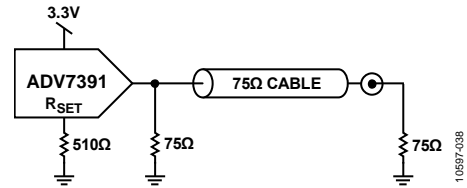

Figure 56. Driving a Video Transmission Line Directly with a DAC

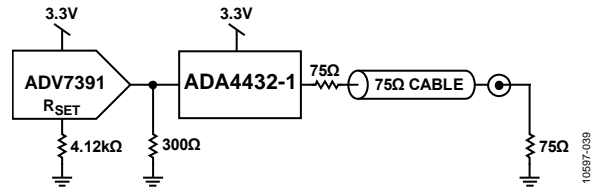
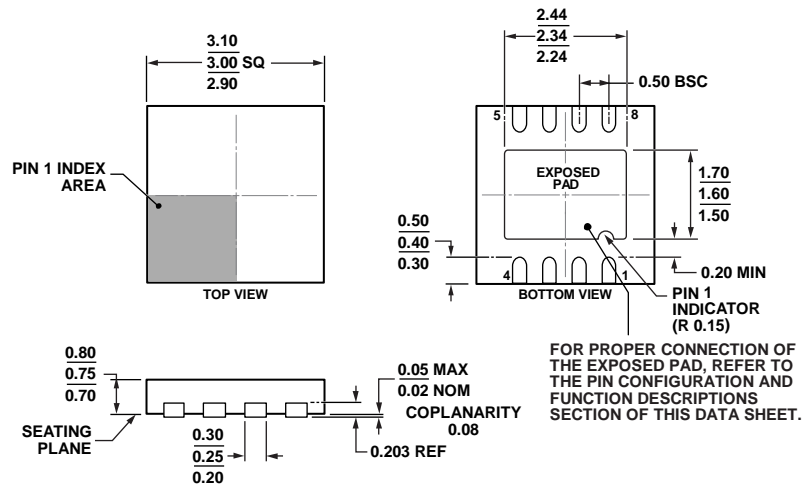

Figure 57. Driving a Video Transmission Line with the [ADA4432-1](#)

OUTLINE DIMENSIONS



COMPLIANT TO JEDEC STANDARDS MO-229-WEED

Figure 58. 8-Lead Lead Frame Chip Scale Package [LFCSP]  
3 mm x 3 mm Body and 0.75 mm Package Height  
(CP-8-21)

Dimensions shown in millimeters

11-28-2012-C

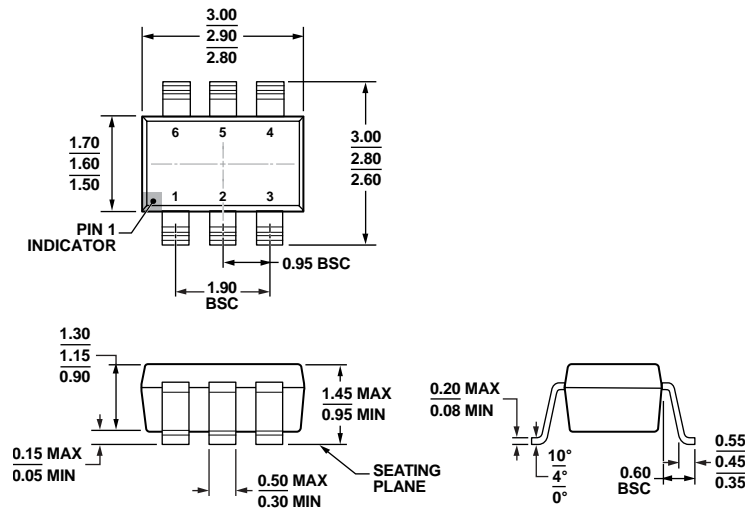

COMPLIANT TO JEDEC STANDARDS MO-178-AB

Figure 59. 6-Lead Small Outline Transistor Package [SOT-23]  
(RJ-6)

Dimensions shown in millimeters

12-16-2008-A

## ORDERING GUIDE

Model <sup>1,2</sup>	Temperature Range	Package Description	Package Option	Branding	Ordering Quantity
ADA4432-1BRJZ-R2	-40°C to +125°C	6-Lead Small Outline Transistor Package [SOT-23]	RJ-6	322	250
ADA4432-1BRJZ-R7	-40°C to +125°C	6-Lead Small Outline Transistor Package [SOT-23]	RJ-6	322	3000
ADA4432-1WBRJZ-R7	-40°C to +125°C	6-Lead Small Outline Transistor Package [SOT-23]	RJ-6	323	3000
ADA4432-1BCPZ-R2	-40°C to +125°C	8-Lead Lead Frame Chip Scale Package [LFCSP]	CP-8-21	321	250
ADA4432-1BCPZ-R7	-40°C to +125°C	8-Lead Lead Frame Chip Scale Package [LFCSP]	CP-8-21	321	1500
ADA4432-1WBPCZ-R7	-40°C to +125°C	8-Lead Lead Frame Chip Scale Package [LFCSP]	CP-8-21	H33	1500
ADA4433-1BCPZ-R2	-40°C to +125°C	8-Lead Lead Frame Chip Scale Package [LFCSP]	CP-8-21	331	250
ADA4433-1BCPZ-R7	-40°C to +125°C	8-Lead Lead Frame Chip Scale Package [LFCSP]	CP-8-21	331	1500
ADA4433-1WBPCZ-R7	-40°C to +125°C	8-Lead Lead Frame Chip Scale Package [LFCSP]	CP-8-21	H2Z	1500
ADA4432-1BRJ-EBZ		SOT-23 Evaluation Board			
ADA4432-1BCP-EBZ		LFCSP Evaluation Board			
ADA4433-1BCP-EBZ		Evaluation Board			

<sup>1</sup> Z = RoHS Compliant Part.

<sup>2</sup> W = Qualified for Automotive Applications.

## AUTOMOTIVE PRODUCTS

The [ADA4432-1W](#) and [ADA4433-1W](#) models are available with controlled manufacturing to support the quality and reliability requirements of automotive applications. Note that these automotive models may have specifications that differ from the commercial models; therefore, designers should review the Specifications section of this data sheet carefully. Only the automotive grade products shown are available for use in automotive applications. Contact your local Analog Devices account representative for specific product ordering information and to obtain the specific Automotive Reliability reports for these models.

## Looking for pricing, stock, or lifecycle information?

Click below to explore more details on WIN SOURCE:

- ⊖ [View ADA4433-1WBCPZ-R2 on WIN SOURCE](#)
- ⊖ [Analog Devices Inc. Information](#)

## Optimize Your Supply Chain with WIN SOURCE Solutions

- ✓ Global Sourcing Solution
- ✓ Obsolete Management
- ✓ Cost Control Management
- ✓ Shortage Management
- ✓ Alternative Solution
- ✓ Excess Inventory Management