



**THE DATASHEET OF
AD7622BCPZ**



FEATURES

Throughput

- 2 MSPS (wideband warp and warp mode)
- 1.5 MSPS (normal mode)
- INL: ± 0.5 LSB typical, ± 1.5 LSB maximum (± 23 ppm of FSR)
- 16-bit resolution with no missing codes
- Dynamic range: 92.5 dB typical
- SINAD: 91 dB minimum @ 20 kHz ($V_{REF} = 2.5$ V)
- THD: -115 dB typical @ 20 kHz ($V_{REF} = 2.5$ V)
- 2.048 V internal reference: typical drift 8 ppm/ $^{\circ}$ C; TEMP output
- Differential input range: $\pm V_{REF}$ (V_{REF} up to 2.5 V)
- No pipeline delay (SAR architecture)
- Parallel (16-, or 8-bit bus) and serial 5 V/3.3 V/2.5 V interface
- SPI[®]/QSPI[™]/MICROWIRE[™]/DSP compatible
- Single 2.5 V supply operation
- Power dissipation
 - 70 mW typical @ 2 MSPS with internal REF
 - 2 μ W in power-down mode
- Pb-free, 48-lead LQFP and 48-lead LFCSP
- Pin compatible with other PuISAR 48-lead ADCs

APPLICATIONS

- Medical instruments
- High speed data acquisition/high dynamic data acquisition
- Digital signal processing
- Spectrum analysis
- Instrumentation
- Communications
- ATE

GENERAL DESCRIPTION

The AD7622 is a 16-bit, 2 MSPS, charge redistribution SAR, fully differential, analog-to-digital converter (ADC) that operates from a single 2.5 V power supply. The part contains a high speed, 16-bit sampling ADC, an internal conversion clock, an internal reference (and buffer), error correction circuits, and both serial and parallel system interface ports. It features two very high sampling rate modes (wideband warp and warp) and a fast mode (normal) for asynchronous rate applications. The AD7622 is hardware factory calibrated and tested to ensure ac parameters, such as signal-to-noise ratio (SNR), in addition to the more traditional dc parameters of gain, offset, and linearity. The AD7622 is available in Pb-free only packages with operation specified from -40° C to $+85^{\circ}$ C.

Rev. A

Information furnished by Analog Devices is believed to be accurate and reliable. However, no responsibility is assumed by Analog Devices for its use, nor for any infringements of patents or other rights of third parties that may result from its use. Specifications subject to change without notice. No license is granted by implication or otherwise under any patent or patent rights of Analog Devices. Trademarks and registered trademarks are the property of their respective owners.

FUNCTIONAL BLOCK DIAGRAM

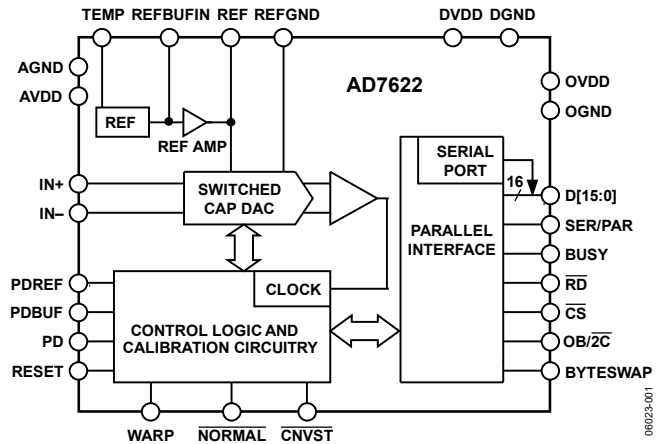

Figure 1.

Table 1. PuISAR 48-Lead ADC Selection

Type/kSPS	100 to 250	500 to 570	650 to 1000	>1000
Pseudo Differential	AD7651, AD7660, AD7661	AD7650, AD7652, AD7664, AD7666	AD7653, AD7667	
True Bipolar	AD7610, AD7663	AD7665	AD7612, AD7671	
True Differential	AD7675	AD7676	AD7677	AD7621, AD7622, AD7623
18-Bit Multichannel/Simultaneous	AD7631, AD7678	AD7679, AD7654	AD7634, AD7674, AD7655	AD7641, AD7643

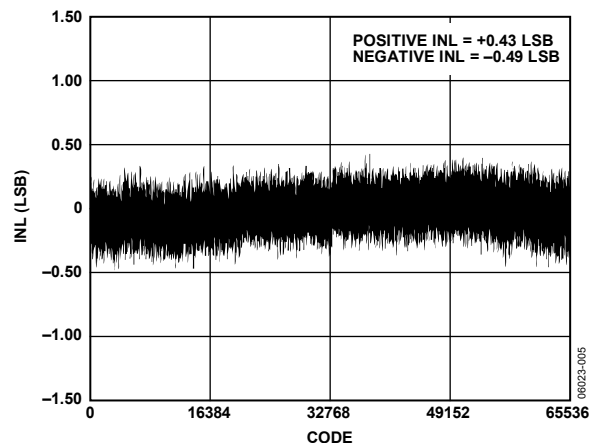

Figure 2. Integral Nonlinearity vs. Code

TABLE OF CONTENTS

Features	1	Multiplexed Inputs.....	17
Applications	1	Driver Amplifier Choice	18
General Description	1	Voltage Reference Input.....	19
Functional Block Diagram	1	Power Supply	20
Revision History	2	Conversion Control	20
Specifications	3	Interfaces	21
Timing Specifications	5	Digital Interface.....	21
Absolute Maximum Ratings	7	Parallel Interface.....	21
ESD Caution.....	7	Serial interface	22
Pin Configuration and Function Descriptions	8	Master Serial Interface.....	22
Terminology.....	11	Slave Serial Interface	24
Typical Performance Characteristics.....	12	Microprocessor Interfacing	26
Applications Information.....	15	Application Hints.....	27
Circuit Information	15	Layout	27
Converter Operation.....	15	Evaluating the AD7622 Performance.....	27
Modes of Operation	15	Outline Dimensions.....	28
Transfer Functions.....	16	Ordering Guide	28
Typical Connection Diagram	17		
Analog Inputs	17		

REVISION HISTORY**8/2020—Rev. 0 to Rev. A**

Changed CP-48-1 to CP-48-4.....	Throughout
Added Figure 5; Renumbered Sequentially	8
Updated Outline Dimensions.....	28
Changes to Ordering Guide.....	28

6/2006—Revision 0: Initial Version

SPECIFICATIONS

AVDD = DVDD = 2.5 V; OVDD = 2.3 V to 3.6 V; V_{REF} = 2.5 V; all specifications T_{MIN} to T_{MAX}, unless otherwise noted.

Table 2.

Parameter	Conditions	Min	Typ	Max	Unit
RESOLUTION		16			Bits
ANALOG INPUT					
Voltage Range	V _{IN+} – V _{IN-}	–V _{REF}		+V _{REF}	V
Operating Input Voltage	V _{IN+} , V _{IN-} to AGND	–0.1		AVDD ¹	V
Analog Input CMRR	f _{IN} = 100 kHz		58		dB
Input Current	2 MSPS throughput		3.5		μA
Input Impedance ²					
THROUGHPUT SPEED					
Complete Cycle	Wideband warp, warp modes			500	ns
Throughput Rate	Wideband warp, warp modes	0.001		2	MSPS
Time Between Conversions	Wideband warp, warp modes			1	ms
Complete Cycle	Normal mode			667	ns
Throughput Rate	Normal mode	0		1.5	MSPS
DC ACCURACY					
Integral Linearity Error ³	T _{MIN} to T _{MAX} = –40°C to +85°C	–1.5	±0.5	+1.5	LSB ⁴
No Missing Codes		16			Bits
Differential Linearity Error		–1		+1.25	LSB
Transition Noise	V _{REF} = 2.5 V		0.5		LSB
Transition Noise	V _{REF} = 2.048 V		0.6		LSB
Zero Error, T _{MIN} to T _{MAX} ⁵		–10		+10	LSB
Zero Error Temperature Drift			±0.5		ppm/°C
Gain Error, T _{MIN} to T _{MAX} ⁵		–8		+8	LSB
Gain Error Temperature Drift			±0.5		ppm/°C
Power Supply Sensitivity	AVDD = 2.5 V ± 5%		±4		LSB
AC ACCURACY					
Dynamic Range	V _{REF} = 2.5 V	91.5	92.5		dB ⁶
Signal-to-Noise	f _{IN} = 20 kHz, V _{REF} = 2.5 V	91	92		dB
	f _{IN} = 20 kHz, V _{REF} = 2.048 V	89.5	90.5		dB
	f _{IN} = 100 kHz, V _{REF} = 2.5 V		91		dB
Spurious-Free Dynamic Range	f _{IN} = 20 kHz, V _{REF} = 2.5 V		117		dB
	f _{IN} = 20 kHz, V _{REF} = 2.048 V		110		dB
	f _{IN} = 100 kHz, V _{REF} = 2.5 V		101		dB
Total Harmonic Distortion	f _{IN} = 20 kHz, V _{REF} = 2.5 V		–115		dB
	f _{IN} = 20 kHz, V _{REF} = 2.048 V		–109		dB
	f _{IN} = 100 kHz, V _{REF} = 2.5 V		–100		dB
Signal-to-(Noise + Distortion)	f _{IN} = 20 kHz, V _{REF} = 2.5 V	91	92		dB
	f _{IN} = 20 kHz, V _{REF} = 2.048 V	89.5	90.5		dB
	f _{IN} = 100 kHz, V _{REF} = 2.5 V		91		dB
–3 dB Input Bandwidth			50		MHz
SAMPLING DYNAMICS					
Aperture Delay			1		ns
Aperture Jitter			5		ps rms
Transient Response	Full-scale step			140	ns
INTERNAL REFERENCE					
Output Voltage	PDREF = PDBUF = low REF @ 25°C	2.038	2.048	2.058	V
Temperature Drift	–40°C to +85°C		±8		ppm/°C
Line Regulation	AVDD = 2.5 V ± 5%		±15		ppm/V

AD7622

Parameter	Conditions	Min	Typ	Max	Unit
Turn-On Settling Time	$C_{REF} = 10 \mu\text{F}$		5		ms
REFBUFIN Output Voltage	REFBUFIN @ 25°C		1.19		V
REFBUFIN Output Resistance			6.33		k Ω
EXTERNAL REFERENCE	PDREF = PDBUF = high				
Voltage Range	REF	1.8	2.5	AVDD + 0.1	V
Current Drain	2 MSPS throughput		150		μA
REFERENCE BUFFER	PDREF = high, PDBUF = low				
REFBUFIN Input Voltage Range	REF = 2.048 V typ	1.05	1.2	1.30	V
REFBUFIN Input Current	REFBUFIN = 1.2 V		1		nA
TEMPERATURE PIN					
Voltage Output	@ 25°C		278		mV
Temperature Sensitivity			1		mV/°C
Output Resistance			4.7		k Ω
DIGITAL INPUTS					
Logic Levels					
V_{IL}		-0.3		+0.6	V
V_{IH}		1.7		5.25	V
I_{IL}		-1		+1	μA
I_{IH}		-1		+1	μA
DIGITAL OUTPUTS					
Data Format ⁷					
Pipeline Delay ⁸					
V_{OL}	$I_{SINK} = 500 \mu\text{A}$			0.4	V
V_{OH}	$I_{SOURCE} = -500 \mu\text{A}$	OVDD - 0.3			V
POWER SUPPLIES					
Specified Performance					
AVDD		2.37	2.5	2.63	V
DVDD		2.37	2.5	2.63	V
OVDD		2.30 ⁹		3.6	V
Operating Current ¹⁰	2 MSPS throughput				
AVDD ¹¹	With internal reference		24		mA
AVDD	Without internal reference		23		mA
DVDD			2.5		mA
OVDD ¹²			1		mA
Power Dissipation ¹¹					
With Internal Reference ¹⁰	2 MSPS throughput		70	85	mW
Without Internal Reference ¹⁰	2 MSPS throughput		65	80	mW
In Power-Down Mode ¹²	PD = high		2		μW
TEMPERATURE RANGE ¹³					
Specified Performance	T_{MIN} to T_{MAX}	-40		+85	°C

¹ When using an external reference. With the internal reference, the input range is -0.1 V to V_{REF} .

² See Analog Inputs section.

³ Linearity is tested using endpoints, not best fit.

⁴ LSB means least significant bit. With the ± 2.048 V input range, 1 LSB is 62.5 μV .

⁵ See Voltage Reference Input section. These specifications do not include the error contribution from the external reference.

⁶ All specifications in dB are referred to a full-scale input FS. Tested with an input signal at 0.5 dB below full-scale, unless otherwise specified.

⁷ Parallel or serial 16-bit.

⁸ Conversion results are available immediately after completed conversion.

⁹ See the Absolute Maximum Ratings section.

¹⁰ In wideband and warp modes. Tested in parallel reading mode.

¹¹ With internal reference, PDREF and PDBUF are low; without internal reference, PDREF and PDBUF are high.

¹² With all digital inputs forced to OVDD.

¹³ Consult sales for extended temperature range.

TIMING SPECIFICATIONS

AVDD = DVDD = 2.5 V; OVDD = 2.3 V to 3.6 V; V_{REF} = 2.5 V; all specifications T_{MIN} to T_{MAX}, unless otherwise noted.

Table 3.

Parameter	Symbol	Min	Typ	Max	Unit
CONVERSION AND RESET (Refer to Figure 32 and Figure 33)					
Convert Pulse Width	t ₁	15		70 ¹	ns
Time Between Conversions (Warp Mode ² /Normal Mode ³)	t ₂	500/667			ns
CNVST Low to BUSY High Delay	t ₃			23	ns
BUSY High All Modes (Except Master Serial Read After Convert)					
Warp Mode/Normal Mode	t ₄			360/485	ns
Aperture Delay	t ₅		1		ns
End of Conversion to BUSY Low Delay	t ₆	10			ns
Conversion Time (Warp Mode/Normal Mode)	t ₇			360/485	ns
Acquisition Time (Warp Mode/Normal Mode)	t ₈	140/182			ns
RESET Pulse Width	t ₉	15			ns
RESET Low to BUSY High Delay ⁴	t ₃₈		10		ns
BUSY High Time from RESET Low ⁴	t ₃₉		500		ns
PARALLEL INTERFACE MODES (Refer to Figure 34 to Figure 37)					
$\overline{\text{CNVST}}$ Low to Data Valid Delay (Warp Mode/Normal Mode)	t ₁₀			360/485	ns
Data Valid to BUSY Low Delay	t ₁₁	2			ns
Bus Access Request to Data Valid	t ₁₂			20	ns
Bus Relinquish Time	t ₁₃	2		15	ns
MASTER SERIAL INTERFACE MODES⁵ (Refer to Figure 38 and Figure 39)					
$\overline{\text{CS}}$ Low to SYNC Valid Delay	t ₁₄			10	ns
$\overline{\text{CS}}$ Low to Internal SCLK Valid Delay ⁵	t ₁₅			10	ns
$\overline{\text{CS}}$ Low to SDOUT Delay	t ₁₆			10	ns
$\overline{\text{CNVST}}$ Low to SYNC Delay (Warp Mode/Normal Mode)	t ₁₇		15/135		ns
SYNC Asserted to SCLK First Edge Delay	t ₁₈	2			ns
Internal SCLK Period ⁶	t ₁₉	8		20	ns
Internal SCLK High ⁶	t ₂₀	2			ns
Internal SCLK Low ⁶	t ₂₁	3			ns
SDOUT Valid Setup Time ⁶	t ₂₂	1			ns
SDOUT Valid Hold Time ⁶	t ₂₃	0			ns
SCLK Last Edge to SYNC Delay ⁶	t ₂₄	0			ns
$\overline{\text{CS}}$ High to SYNC HI-Z	t ₂₅			10	ns
$\overline{\text{CS}}$ High to Internal SCLK HI-Z	t ₂₆			10	ns
$\overline{\text{CS}}$ High to SDOUT HI-Z	t ₂₇			10	ns
BUSY High in Master Serial Read After Convert ⁶	t ₂₈		See Table 4		ns
$\overline{\text{CNVST}}$ Low to SYNC Asserted Delay (Warp Mode/Normal Mode)	t ₂₉		375/500		ns
SYNC Deasserted to BUSY Low Delay	t ₃₀		13		ns
SLAVE SERIAL INTERFACE MODES (Refer to Figure 41 and Figure 42)					
External SCLK Setup Time	t ₃₁	5			ns
External SCLK Active Edge to SDOUT Delay	t ₃₂	1		8	ns
SDIN Setup Time	t ₃₃	5			ns
SDIN Hold Time	t ₃₄	5			ns
External SCLK Period	t ₃₅	12.5			ns
External SCLK High	t ₃₆	5			ns
External SCLK Low	t ₃₇	5			ns

See Notes on next page.

¹ See the Conversion Control section.

² All timings for wideband warp mode are the same as warp mode.

³ In warp mode only, the maximum time between conversions is 1 ms; otherwise, there is no required maximum time.

⁴ See the Digital Interface section and the RESET section.

⁵ In serial interface modes, the SYNC, SCLK, and SDOUT timings are defined with a maximum load C_L of 10 pF; otherwise, the load is 60 pF maximum.

⁶ In serial master read during convert mode. See Table 4 for serial master read after convert mode timing specifications.

Table 4. Serial Clock Timings in Master Read After Convert Mode

DIVSCLK[1] DIVSCLK[0]	Symbol	0 0	0 1	1 0	1 1	Unit
SYNC to SCLK First Edge Delay Minimum	t_{18}	3	3	3	3	ns
Internal SCLK Period Minimum	t_{19}	8	16	32	64	ns
Internal SCLK Period Maximum	t_{19}	20	40	60	140	ns
Internal SCLK High Minimum	t_{20}	2	8	16	32	ns
Internal SCLK Low Minimum	t_{21}	2	8	16	32	ns
SDOUT Valid Setup Time Minimum	t_{22}	1	5	15	5	ns
SDOUT Valid Hold Time Minimum	t_{23}	0	0.5	10	28	ns
SCLK Last Edge to SYNC Delay Minimum	t_{24}	0	0.5	9	26	ns
BUSY High Width Maximum						
Warp Mode	t_{28}	0.64	0.92	1.47	2.57	μ s
Normal Mode	t_{28}	0.76	1.04	1.59	2.69	μ s

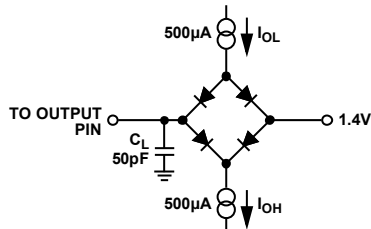

NOTE
IN SERIAL INTERFACE MODES, THE SYNC, SCLK, AND
SDOUT TIMING ARE DEFINED WITH A MAXIMUM LOAD
 C_L OF 10pF; OTHERWISE, THE LOAD IS 60pF MAXIMUM.

Figure 3. Load Circuit for Digital Interface Timing,
SDOUT, SYNC, and SCLK Outputs, $C_L = 10$ pF

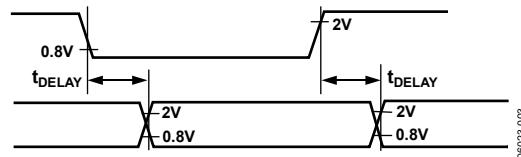

Figure 4. Voltage Reference Levels for Timing

ABSOLUTE MAXIMUM RATINGS

Table 5.

Parameter	Rating
Analog Inputs/Outputs IN+ ¹ , IN−, REF, REFBUF _{IN} , TEMP, INGND, REFGND to AGND	AVDD + 0.3 V to AGND − 0.3 V
Ground Voltage Differences AGND, DGND, OGND	±0.3 V
Supply Voltages AVDD, DVDD	−0.3 V to +2.7 V
OVDD	−0.3 V to +3.8 V
AVDD to DVDD	±2.8 V
AVDD, DVDD to OVDD	−3.8 V to +2.8 V
Digital Inputs PDREF, PDBUF ²	−0.3 V to +5.5 V ±20 mA
Internal Power Dissipation ³	700 mW
Internal Power Dissipation ⁴	2.5 W
Junction Temperature	125°C
Storage Temperature Range	−65°C to +125°C

¹ See Analog Inputs section.

² See Voltage Reference Input section.

³ Specification is for the device in free air:
48-Lead LQFP; $\theta_{JA} = 91^\circ\text{C/W}$, $\theta_{JC} = 30^\circ\text{C/W}$.

⁴ Specification is for the device in free air:
48-Lead LFCSP; $\theta_{JA} = 26^\circ\text{C/W}$.

Stresses above those listed under Absolute Maximum Ratings may cause permanent damage to the device. This is a stress rating only; functional operation of the device at these or any other conditions above those indicated in the operational section of this specification is not implied. Exposure to absolute maximum rating conditions for extended periods may affect device reliability.

ESD CAUTION

ESD (electrostatic discharge) sensitive device. Electrostatic charges as high as 4000 V readily accumulate on the human body and test equipment and can discharge without detection. Although this product features proprietary ESD protection circuitry, permanent damage may occur on devices subjected to high energy electrostatic discharges. Therefore, proper ESD precautions are recommended to avoid performance degradation or loss of functionality.



PIN CONFIGURATION AND FUNCTION DESCRIPTIONS

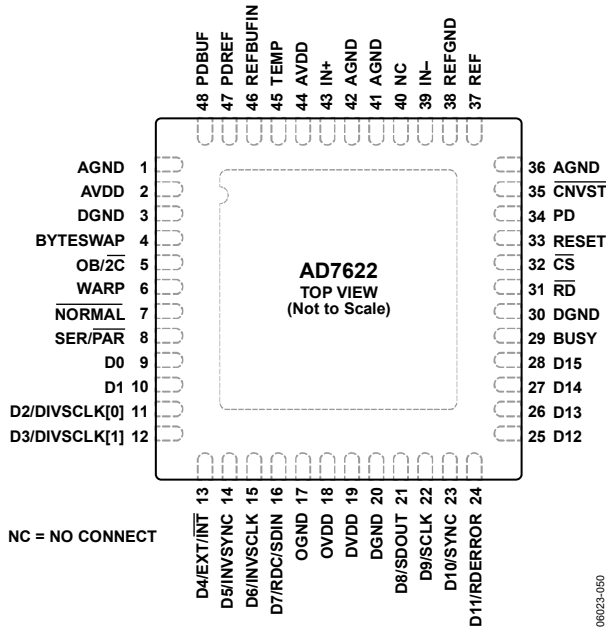

Figure 5. 48-Lead LFCSP Pin Configuration

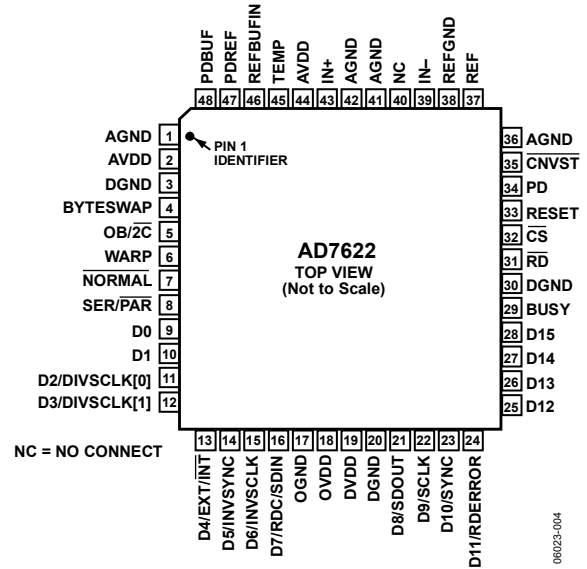

Figure 6. 48-Lead LQFP Pin Configuration

Table 6. Pin Function Descriptions

Pin No.	Mnemonic	Type ¹	Description
1, 36, 41, 42	AGND	P	Analog Power Ground.
2, 44	AVDD	P	Input Analog Power Pins. Nominally 2.5 V.
3	DGND	P	Digital Power Ground.
4	BYTESWAP	DI	Parallel Mode Selection (8-Bit/16-Bit). When high, the LSB is output on D[15:8] and the MSB is output on D[7:0]; when low, the LSB is output on D[7:0] and the MSB is output on D[15:8].
5	OB/2C	DI	Straight Binary/Binary Twos Complement Output. When high, the digital output is straight binary; when low, the MSB is inverted resulting in a twos complement output from its internal shift register.
6	WARP	DI	Conversion Mode Selection. When WARP = high and NORMAL = high, this selects wideband warp mode with slightly improved linearity and THD. When WARP = high and NORMAL = low, this selects warp mode. In either mode, these are the fastest modes; maximum throughput is achievable, and a minimum conversion rate must be applied to guarantee full specified accuracy.
7	NORMAL	DI	Conversion Mode Selection. When NORMAL = low and WARP = low, this input selects normal mode where full accuracy is maintained independent of the minimum conversion rate.
8	SER/PAR	DI/O	Serial/Parallel Selection Input. When SER/PAR = high, the serial interface is selected and some bits of the data bus are used as a serial port; the remaining data bits are high impedance outputs. When SER/PAR = low, the parallel port is selected.
9, 10	D[0:1]	DO	Bit 0 and Bit 1 of the Parallel Port Data Output Bus. These pins are always outputs, regardless of the interface mode.
11, 12	D[2:3] or DIVSCLK[0:1]	DI/O	When SER/PAR = low, these outputs are used as Bit 2 and Bit 3 of the parallel port data output bus. When SER/PAR = high, serial clock division selection. When using serial master read after convert mode (EXT/INT = low, RDC/SDIN = low), these inputs can be used to slow down the internally generated serial clock that clocks the data output. In other serial modes, these pins are high impedance outputs.

Pin No.	Mnemonic	Type ¹	Description
13	D4 or EXT/ $\overline{\text{INT}}$	DI/O	When $\text{SER}/\overline{\text{PAR}}$ = low, this output is used as Bit 4 of the parallel port data output bus. When $\text{SER}/\overline{\text{PAR}}$ = high, serial clock source select. This input is used to select the internally generated (master) or external (slave) serial data clock. When $\text{EXT}/\overline{\text{INT}}$ = low, master mode. The internal serial clock is selected on SCLK output. When $\text{EXT}/\overline{\text{INT}}$ = high, slave mode. The output data is synchronized to an external clock signal, gated by $\overline{\text{CS}}$, connected to the SCLK input.
14	D5 or INVS $\overline{\text{SYNC}}$	DI/O	When $\text{SER}/\overline{\text{PAR}}$ = low, this output is used as Bit 5 of the parallel port data output bus. When $\text{SER}/\overline{\text{PAR}}$ = high, invert sync select. In serial master mode ($\text{EXT}/\overline{\text{INT}}$ = low), this input is used to select the active state of the SYNC signal. When INVS $\overline{\text{SYNC}}$ = low, SYNC is active high. When INVS $\overline{\text{SYNC}}$ = high, SYNC is active low.
15	D6 or INV $\overline{\text{SCLK}}$	DI/O	When $\text{SER}/\overline{\text{PAR}}$ = low, this output is used as Bit 6 of the parallel port data output bus. When $\text{SER}/\overline{\text{PAR}}$ = high, invert SCLK select. In all serial modes, this input is used to invert the SCLK signal.
16	D7 or RDC or SDIN	DI/O	When $\text{SER}/\overline{\text{PAR}}$ = low, this output is used as bit 7 of the parallel port data output bus. When $\text{SER}/\overline{\text{PAR}}$ = high, read during convert. When using serial master mode ($\text{EXT}/\overline{\text{INT}}$ = low), RDC is used to select the read mode. When RDC = high, the previous conversion result is output on SDOUT during conversion and the period of SCLK changes (see the Master Serial Interface section). When RDC = low (read after convert), the current result can be output on SDOUT only when the conversion is complete. When $\text{SER}/\overline{\text{PAR}}$ = low, serial data in. When using serial slave mode, ($\text{EXT}/\overline{\text{INT}}$ = high), SDIN could be used as a data input to daisy-chain the conversion results from two or more ADCs onto a single SDOUT line. The digital data level on SDIN is output on SDOUT with a delay of 16 SCLK periods after the initiation of the read sequence. If not used, connect to OVDD or OGND.
17	OGND	P	Input/Output Interface Digital Power Ground.
18	OVDD	P	Input/Output Interface Digital Power. Nominally at the same supply as the supply of the host interface (2.5 V or 3 V).
19	DVDD	P	Digital Power. Nominally at 2.5 V.
20	DGND	P	Digital Power Ground.
21	D8 or SDOUT	DO	When $\text{SER}/\overline{\text{PAR}}$ = low, this output is used as Bit 8 of the parallel port data output bus. When $\text{SER}/\overline{\text{PAR}}$ = high, serial data output. In serial mode, this pin is used as the serial data output synchronized to SCLK. Conversion results are stored in an on-chip register. The AD7622 provides the conversion result, MSB first, from its internal shift register. The data format is determined by the logic level of $\text{OB}/\overline{2\text{C}}$. In master mode, $\text{EXT}/\overline{\text{INT}}$ = low, SDOUT is valid on both edges of SCLK. In slave mode, $\text{EXT}/\overline{\text{INT}}$ = high: When INV $\overline{\text{SCLK}}$ = low, SDOUT is updated on SCLK rising edge and valid on the next falling edge. ² When INV $\overline{\text{SCLK}}$ = high, SDOUT is updated on SCLK falling edge and valid on the next rising edge. ²
22	D9 or SCLK	DI/O	When $\text{SER}/\overline{\text{PAR}}$ = low, this output is used as Bit 9 of the parallel port data output bus. When $\text{SER}/\overline{\text{PAR}}$ = high, serial clock. In all serial modes, this pin is used as the serial data clock input or output, depending upon the logic state of the $\text{EXT}/\overline{\text{INT}}$ pin. The active edge where the data SDOUT is updated, depends on the logic state of the INV $\overline{\text{SCLK}}$ pin.
23	D10 or SYNC	DO	When $\text{SER}/\overline{\text{PAR}}$ = low, this output is used as Bit 10 of the parallel port data output bus. When $\text{SER}/\overline{\text{PAR}}$ = high, frame synchronization. In serial master mode ($\text{EXT}/\overline{\text{INT}}$ = low), this output is used as a digital output frame synchronization for use with the internal data clock. When a read sequence is initiated and INVS $\overline{\text{SYNC}}$ = low, SYNC is driven high and remains high while SDOUT output is valid. When a read sequence is initiated and INVS $\overline{\text{SYNC}}$ = high, SYNC is driven low and remains low while SDOUT output is valid.

AD7622

Pin No.	Mnemonic	Type ¹	Description
24	D11 or RDERROR	DO	When $\overline{\text{SER/}\overline{\text{PAR}}} = \text{low}$, this output is used as Bit 11 of the parallel port data output bus. When $\overline{\text{SER/}\overline{\text{PAR}}} = \text{high}$, read error. In serial slave mode ($\overline{\text{EXT/}\overline{\text{INT}}} = \text{high}$), this output is used as an incomplete read error flag. If a data read is started and not completed when the current conversion is complete, the current data is lost and RDERROR is pulsed high.
25 to 28	D[12:15]	DO	Bit 12 to Bit 15 of the parallel port data output bus. These pins are always outputs, regardless of the interface mode.
29	BUSY	DO	Busy Output. Transitions high when a conversion is started and remains high until the conversion is complete and the data is latched into the on-chip shift register. The falling edge of BUSY can be used as a data-ready clock signal.
30	DGND	P	Digital Power Ground.
31	$\overline{\text{RD}}$	DI	Read Data. When $\overline{\text{CS}}$ and $\overline{\text{RD}}$ are both low, the interface parallel or serial output bus is enabled.
32	$\overline{\text{CS}}$	DI	Chip Select. When $\overline{\text{CS}}$ and $\overline{\text{RD}}$ are both low, the interface parallel or serial output bus is enabled. $\overline{\text{CS}}$ is also used to gate the external clock in slave serial mode.
33	RESET	DI	Reset Input. When high, resets the AD7622. Current conversion, if any, is aborted. Falling edge of RESET enables the calibration mode indicated by pulsing BUSY high. Refer to the RESET section. If not used, this pin can be tied to DGND.
34	PD	DI	Power-Down Input. When high, power downs the ADC. Power consumption is reduced and conversions are inhibited after the current one is completed.
35	$\overline{\text{CNVST}}$	DI	Conversion Start. A falling edge on $\overline{\text{CNVST}}$ puts the internal sample-and-hold into the hold state and initiates a conversion.
37	REF	AI/O	Reference Output/Input. When $\overline{\text{PDREF/PDBUF}} = \text{low}$, the internal reference and buffer are enabled producing 2.048 V on this pin. When $\overline{\text{PDREF/PDBUF}} = \text{high}$, the internal reference and buffer are disabled allowing an externally supplied voltage reference up to AVDD volts. Decoupling is required with or without the internal reference and buffer. Refer to the Voltage Reference Input section.
38	REFGND	AI	Reference Input Analog Ground.
39	IN-	AI	Differential Negative Analog Input.
40	NC		No Connect.
43	IN+	AI	Differential Positive Analog Input.
45	TEMP	AO	Temperature Sensor Analog Output. Normally, 278 mV @ 25°C with a temperature coefficient of 1 mV/°C. This pin can be used to measure the temperature of the AD7622. See the Temperature Sensor section.
46	REFBUFIN	AI/O	Internal Reference Output/Reference Buffer Input. When $\overline{\text{PDREF/PDBUF}} = \text{low}$, the internal reference and buffer are enabled producing the 1.2 V (typical) band gap output on this pin, which needs external decoupling. The internal fixed gain reference buffer uses this to produce 2.048 V on the REF pin. When using an external reference with the internal reference buffer ($\overline{\text{PDBUF}} = \text{low}$, $\overline{\text{PDREF}} = \text{high}$), applying 1.2 V on this pin produces 2.048 V on the REF pin. Refer to the Voltage Reference Input section.
47	PDREF	DI	Internal Reference Power-Down Input. When low, the internal reference is enabled. When high, the internal reference is powered down and an external reference must be used.
48	PDBUF	DI	Internal Reference Buffer Power-Down Input. When low, the buffer is enabled (must be low when using internal reference). When high, the buffer is powered-down.

¹ AI = analog input; AI/O = bidirectional analog; AO = analog output; DI = digital input; DI/O = bidirectional digital; DO = digital output; P = power.

² With an SCLK period $\geq (2 \times t_{32})$. With an SCLK period $< (2 \times t_{32})$, SDOUT is valid on the next rising edge with $\overline{\text{INVSC}} = \text{low}$ and next falling edge with $\overline{\text{INVSC}} = \text{high}$.

TERMINOLOGY

Integral Nonlinearity Error (INL)

Linearity error refers to the deviation of each individual code from a line drawn from negative full scale through positive full scale. The point used as negative full scale occurs ½ LSB before the first code transition. Positive full scale is defined as a level 1½ LSB beyond the last code transition. The deviation is measured from the middle of each code to the true straight line.

Differential Nonlinearity Error (DNL)

In an ideal ADC, code transitions are 1 LSB apart. Differential nonlinearity is the maximum deviation from this ideal value. It is often specified in terms of resolution for which no missing codes are guaranteed.

Gain Error

The first transition (from 000...00 to 000...01) should occur for an analog voltage ½ LSB above the nominal negative full scale (–2.0479688 V for the ±2.048 V range). The last transition (from 111...10 to 111...11) should occur for an analog voltage 1½ LSB below the nominal full scale (+2.0479531 V for the ±2.048 V range). The gain error is the deviation of the difference between the actual level of the last transition and the actual level of the first transition from the difference between the ideal levels.

Zero Error

The zero error is the difference between the ideal midscale input voltage (0 V) and the actual voltage producing the midscale output code.

Dynamic Range

It is the ratio of the rms value of the full scale to the rms noise measured with the inputs shorted together. The value for dynamic range is expressed in decibels.

Signal-to-Noise Ratio (SNR)

SNR is the ratio of the rms value of the actual input signal to the rms sum of all other spectral components below the Nyquist frequency, excluding harmonics and dc. The value for SNR is expressed in decibels.

Total Harmonic Distortion (THD)

THD is the ratio of the rms sum of the first five harmonic components to the rms value of a full-scale input signal and is expressed in decibels.

Signal to (Noise + Distortion) Ratio (SINAD)

SINAD is the ratio of the rms value of the actual input signal to the rms sum of all other spectral components below the Nyquist frequency, including harmonics but excluding dc. The value for SINAD is expressed in decibels.

Spurious-Free Dynamic Range (SFDR)

The difference, in decibels (dB), between the rms amplitude of the input signal and the peak spurious signal.

Effective Number of Bits (ENOB)

ENOB is a measurement of the resolution with a sine wave input. It is related to SINAD and is expressed in bits by

$$ENOB = [(SINAD_{dB} - 1.76)/6.02]$$

Aperture Delay

Aperture delay is a measure of the acquisition performance and is measured from the falling edge of the \overline{CNVST} input to when the input signal is held for a conversion.

Transient Response

The time required for the AD7622 to achieve its rated accuracy after a full-scale step function is applied to its input.

Reference Voltage Temperature Coefficient

It is derived from the typical shift of output voltage at 25°C on a sample of parts maximum and minimum reference output voltage (V_{REF}) measured at T_{MIN} , $T(25^\circ\text{C})$, and T_{MAX} . It is expressed in ppm/°C using

$$TCV_{REF}(\text{ppm}/^\circ\text{C}) = \frac{V_{REF}(\text{Max}) - V_{REF}(\text{Min})}{V_{REF}(25^\circ\text{C}) \times (T_{MAX} - T_{MIN})} \times 10^6$$

where:

$V_{REF}(\text{Max})$ = Maximum V_{REF} at T_{MIN} , $T(25^\circ\text{C})$, or T_{MAX}

$V_{REF}(\text{Min})$ = Minimum V_{REF} at T_{MIN} , $T(25^\circ\text{C})$, or T_{MAX}

$V_{REF}(25^\circ\text{C})$ = V_{REF} at 25°C

T_{MAX} = +85°C

T_{MIN} = –40°C

TYPICAL PERFORMANCE CHARACTERISTICS

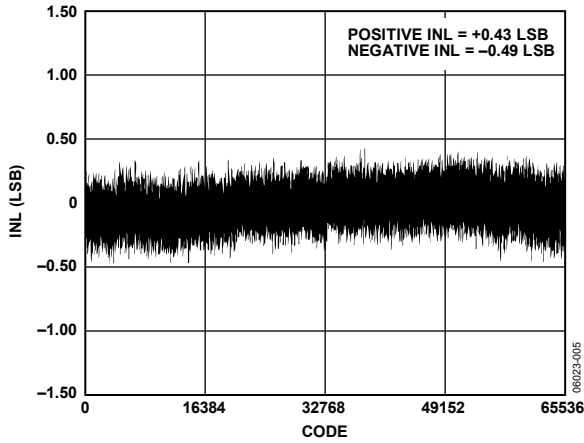

Figure 7. Integral Nonlinearity vs. Code

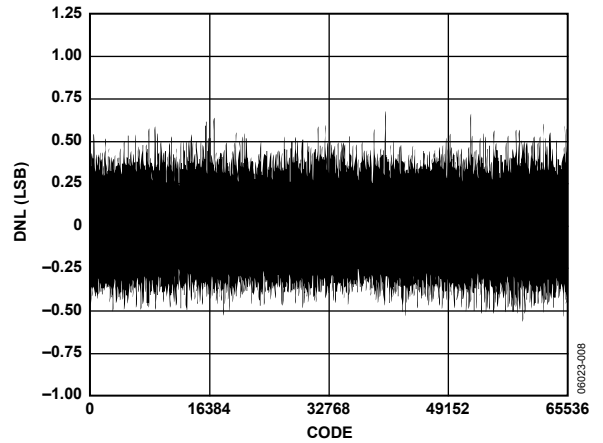

Figure 10. Differential Nonlinearity vs. Code

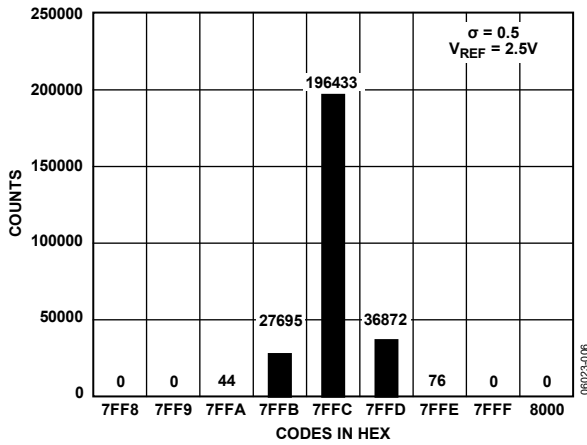

Figure 8. Histogram of 261,120 Conversions of a DC Input at the Code Center (External Reference)

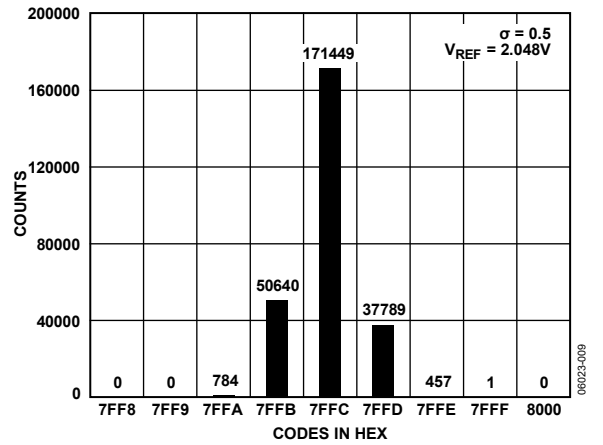

Figure 11. Histogram of 261,120 Conversions of a DC Input at the Code Center (Internal Reference)

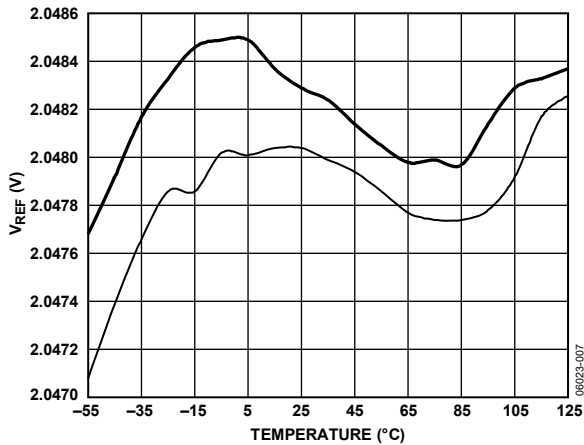

Figure 9. Typical Reference Voltage Output vs. Temperature (2 Units)

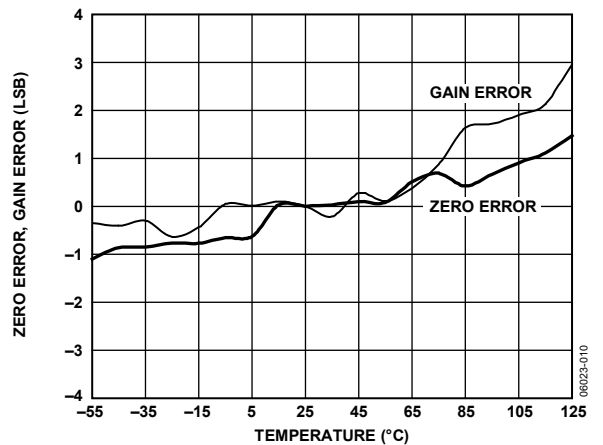

Figure 12. Zero Error, Gain Error vs. Temperature

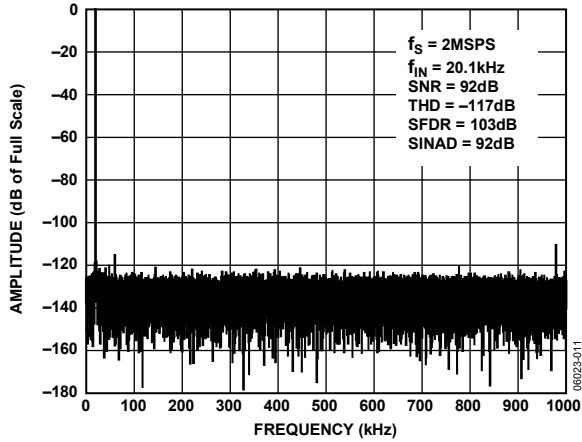

Figure 13. FFT 20 kHz

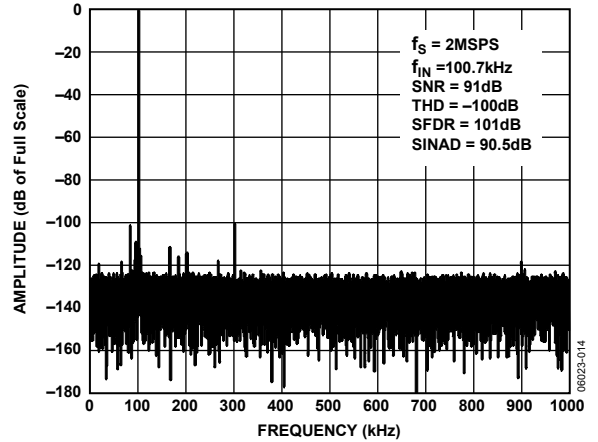

Figure 16. FFT 100 kHz

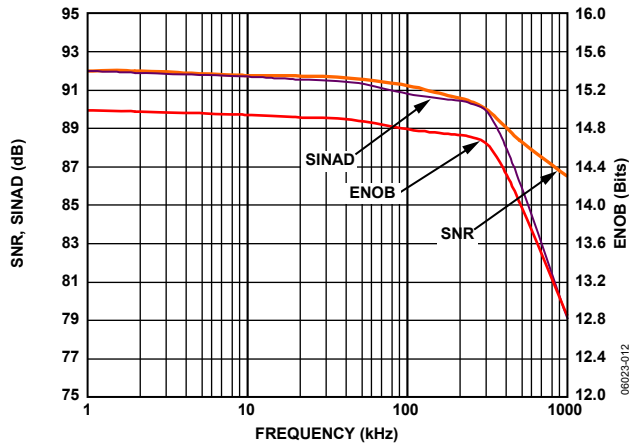

Figure 14. SNR, SINAD, and ENOB vs. Frequency

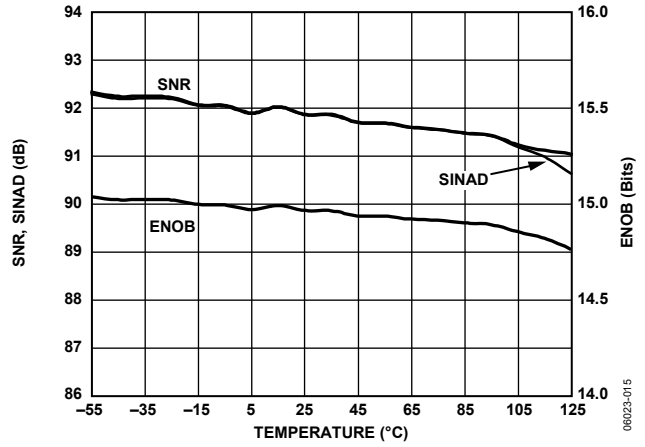

Figure 17. SNR, SINAD, and ENOB vs. Temperature

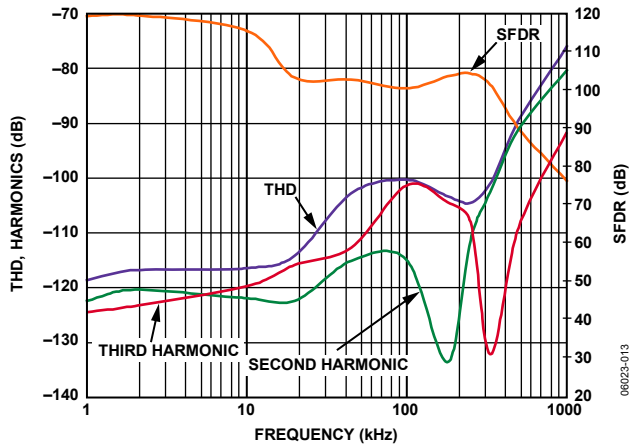

Figure 15. THD, Harmonics, and SFDR vs. Frequency

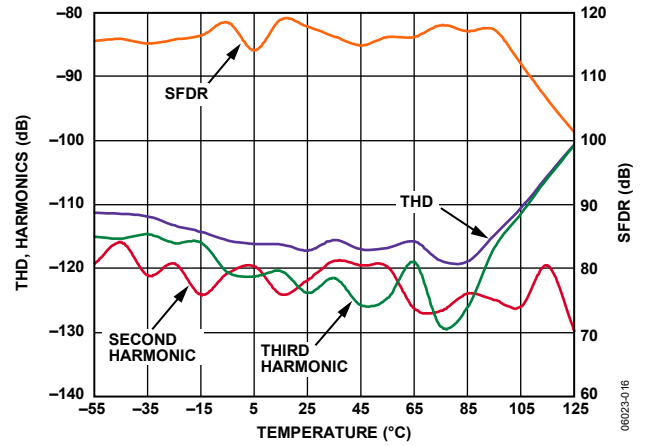

Figure 18. THD, Harmonics, and SFDR vs. Temperature

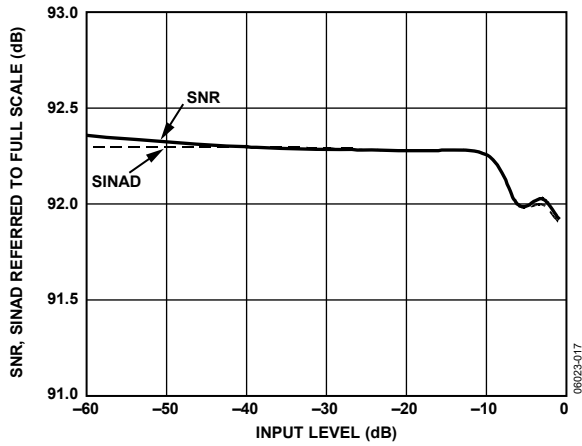

Figure 19. SNR and SINAD vs. Input Level (Referred to Full Scale)

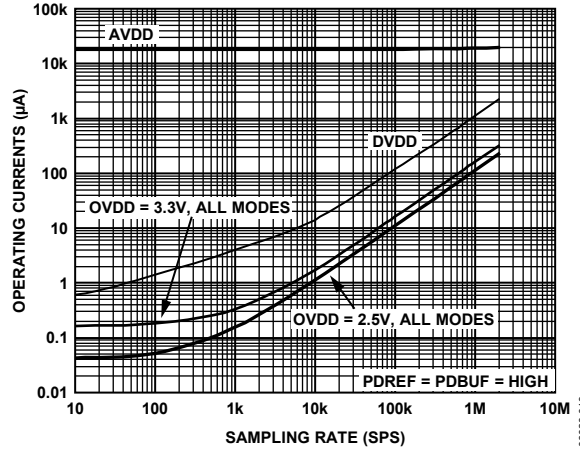

Figure 21. Operating Currents vs. Sample Rate

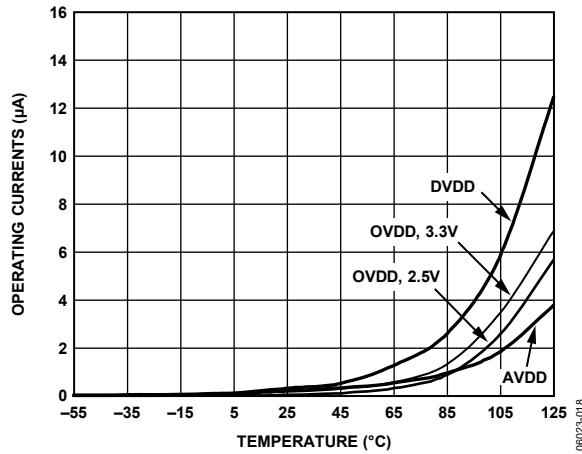

Figure 20. Power-Down Operating Currents vs. Temperature

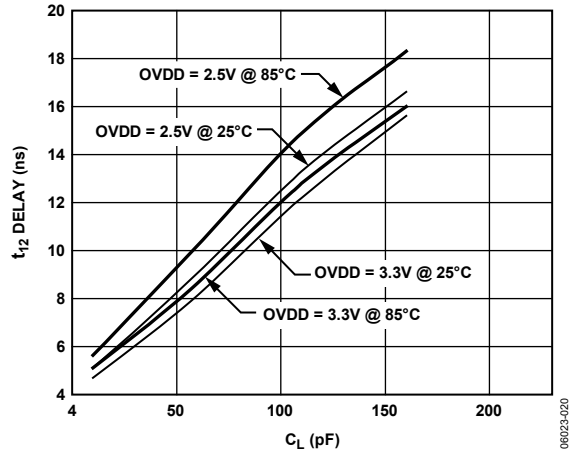

Figure 22. Typical Delay vs. Load Capacitance C_L

APPLICATIONS INFORMATION

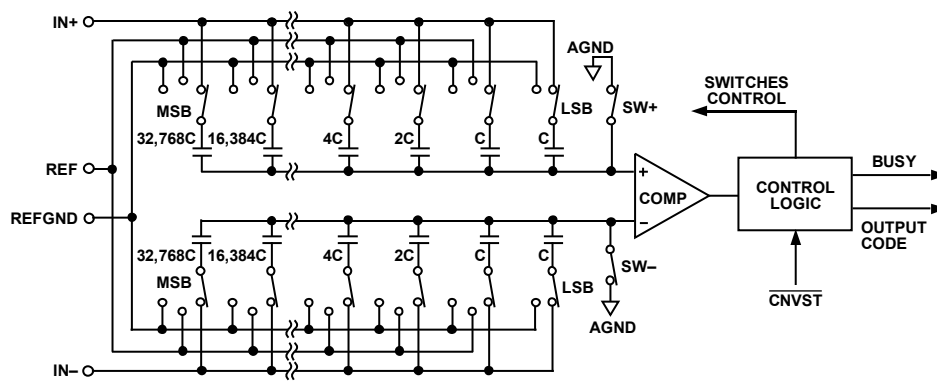

Figure 23. ADC Simplified Schematic

CIRCUIT INFORMATION

The AD7622 is a very fast, low power, single-supply, precise 16-bit ADC using successive approximation architecture. The AD7622 features different modes to optimize performances according to the applications. In warp mode, the AD7622 is capable of converting 2,000,000 samples per second (2 MSPS).

The AD7622 provides the user with an on-chip track-and-hold, successive approximation ADC that does not exhibit any pipeline or latency, making it ideal for multiple multiplexed channel applications.

The AD7622 can operate from a single 2.5 V supply and interface to either 5 V, 3.3 V, or 2.5 V digital logic. It is housed in a 48-lead LQFP package or a tiny 48-lead LFCSP package, which combines space savings with flexibility and allows the AD7622 to be configured as either a serial or a parallel interface. The AD7622 is pin-to-pin compatible with other PulSAR ADC's and is a speed upgrade of the [AD7677](#).

CONVERTER OPERATION

The AD7622 is a successive approximation ADC based on a charge redistribution DAC. Figure 23 shows the simplified schematic of the ADC. The capacitive DAC consists of two identical arrays of 16 binary weighted capacitors that are connected to the two comparator inputs.

During the acquisition phase, terminals of the array tied to the comparator's input are connected to AGND via SW+ and SW-. All independent switches are connected to the analog inputs. Therefore, the capacitor arrays are used as sampling capacitors and acquire the analog signal on the IN+ and IN- inputs. A conversion phase is initiated once the acquisition phase is complete and the CNVST input goes low. When the conversion phase begins, SW+ and SW- are opened first. The two capacitor arrays are then disconnected from the inputs and connected to the REFGND input. Therefore, the differential voltage between the inputs (IN+ and IN-) captured at the end of the acquisition phase is applied to the comparator inputs, causing the

comparator to become unbalanced. By switching each element of the capacitor array between REFGND and REF, the comparator input varies by binary weighted voltage steps ($V_{REF}/2$, $V_{REF}/4$ through $V_{REF}/65536$). The control logic toggles these switches, starting with the MSB first, to bring the comparator back into a balanced condition. After the completion of this process, the control logic generates the ADC output code and brings BUSY output low.

MODES OF OPERATION

The AD7622 features three modes of operations: wideband warp, warp, and normal. Each of these modes is more suitable for specific applications.

The wideband warp ($\overline{WARP} = \text{high}$, $\overline{NORMAL} = \text{high}$) and warp ($\overline{WARP} = \text{high}$, $\overline{NORMAL} = \text{low}$) modes allow the fastest conversion rate of up to 2 MSPS. However, in these modes, the full specified accuracy is guaranteed only when the time between conversions does not exceed 1 ms. If the time between two consecutive conversions is longer than 1 ms (for instance after power-up), the first conversion result should be ignored. These modes make the AD7622 ideal for applications where both high accuracy and fast sample rates are required. Wideband warp mode offers slightly improved linearity and THD over warp mode.

Normal mode ($\overline{NORMAL} = \text{low}$, $\overline{WARP} = \text{low}$) is the fastest mode (1.5 MSPS) without any limitation on time between conversions. This mode makes the AD7622 ideal for asynchronous applications, such as data acquisition systems, where both high accuracy and fast sample rates are required.

AD7622

TRANSFER FUNCTIONS

Using the $\overline{OB/2C}$ digital input, the AD7622 offers two output codings: straight binary and twos complement. The LSB size with $V_{REF} = 2.048\text{ V}$ is $2 \times V_{REF} / 65536$ which is $62.5\ \mu\text{V}$. Refer to Figure 24 and Table 7 for the ideal transfer characteristic.

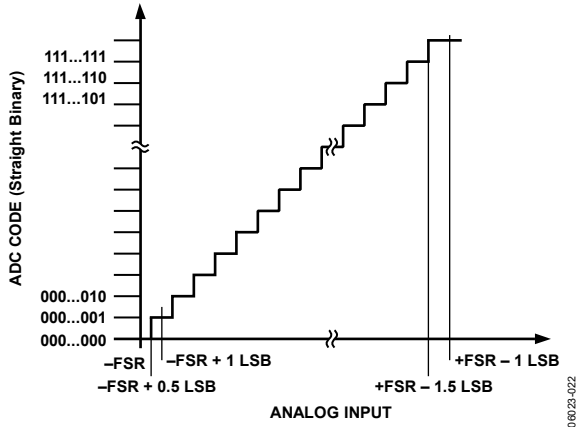

Figure 24. ADC Ideal Transfer Function

Table 7. Output Codes and Ideal Input Voltages

Description	Analog Input $V_{REF} = 2.048\text{ V}$	Digital Output Code (Hex)	
		Straight Binary	Twos Complement
FSR - 1 LSB	+2.047938 V	0xFFFF ¹	0x7FFF ¹
FSR - 2 LSB	+2.047875 V	0xFFFE	0x7FFE
Midscale + 1 LSB	+62.5 μV	0x8001	0x0001
Midscale	0 V	0x8000	0x0000
Midscale - 1 LSB	-62.5 μV	0x7FFF	0xFFFF
-FSR + 1 LSB	-2.047938 V	0x0001	0x8001
-FSR	-2.048 V	0x0000 ²	0x8000 ²

¹ This is also the code for overrange analog input ($V_{IN+} - V_{IN-}$ above $+V_{REF} - V_{REFGND}$).

² This is also the code for underrange analog input ($V_{IN+} - V_{IN-}$ below $-V_{REF} + V_{REFGND}$).

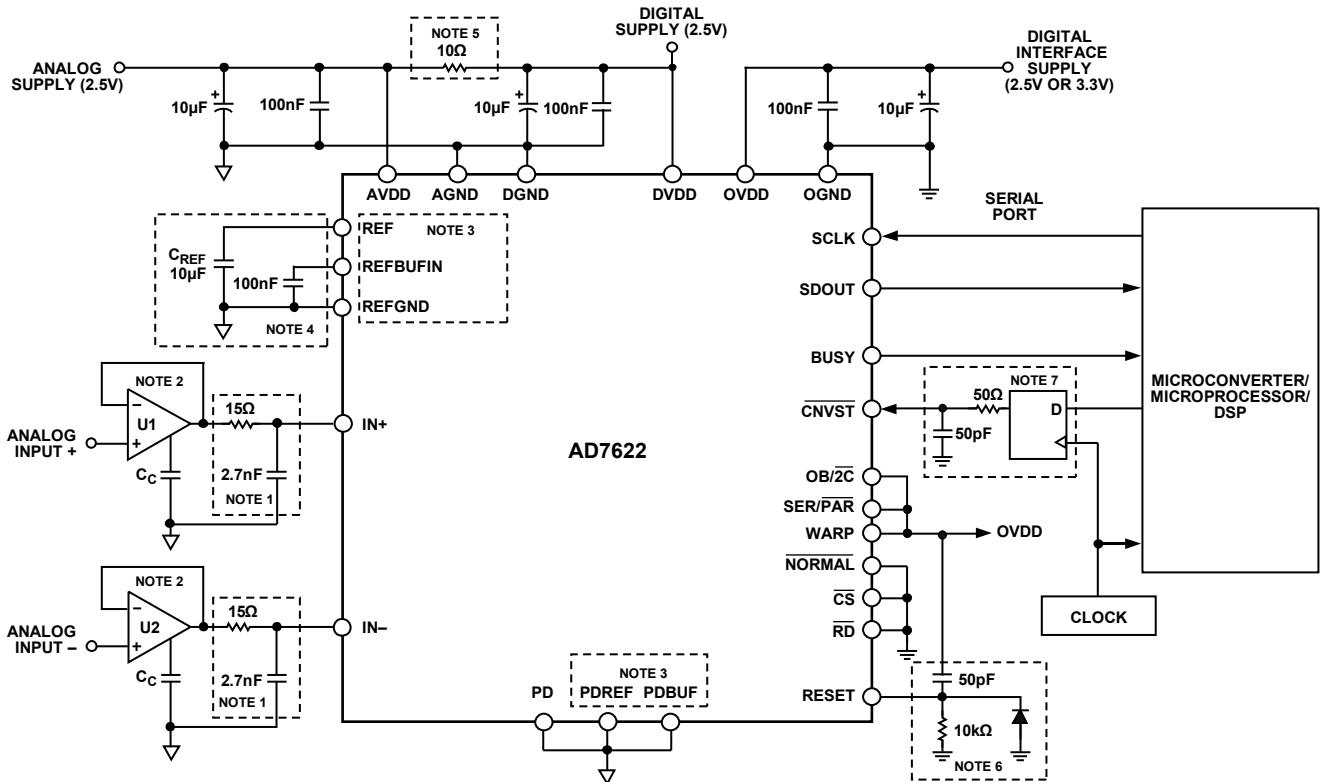

1. SEE ANALOG INPUTS SECTION.
2. THE AD8021 IS RECOMMENDED. SEE DRIVER AMPLIFIER CHOICE SECTION.
3. THE CONFIGURATION SHOWN IS USING THE INTERNAL REFERENCE. SEE VOLTAGE REFERENCE INPUT SECTION.
4. A $10\ \mu\text{F}$ CERAMIC CAPACITOR (X5R, 1206 SIZE) IS RECOMMENDED (FOR EXAMPLE, PANASONIC ECJ3YB0J106M). SEE VOLTAGE REFERENCE INPUT SECTION.
5. OPTION, SEE POWER SUPPLY SECTION.
6. OPTION, SEE POWER-UP SECTION.
7. OPTIONAL LOW JITTER \overline{CNVST} , SEE CONVERSION CONTROL SECTION.

Figure 25. Typical Connection Diagram

TYPICAL CONNECTION DIAGRAM

Figure 25 shows a typical connection diagram for the AD7622. Different circuitry shown in this diagram is optional and is discussed in the following sections.

ANALOG INPUTS

Figure 26 shows an equivalent circuit of the input structure of the AD7622.

The two diodes, D_1 and D_2 , provide ESD protection for the analog inputs $IN+$ and $IN-$. Care must be taken to ensure that the analog input signal never exceeds the supply rails by more than 0.3 V, because this causes the diodes to become forward-biased and to start conducting current. These diodes can handle a forward-biased current of 100 mA maximum. For instance, these conditions could eventually occur when the input buffer's $U1$ or $U2$ supplies are different from $AVDD$. In such a case, an input buffer with a short-circuit current limitation can be used to protect the part.

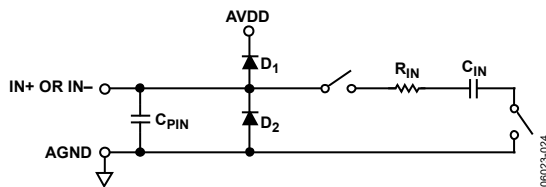

Figure 26. AD7622 Simplified Analog Input

The analog input of the AD7622 is a true differential structure. By using this differential input, small signals common to both inputs are rejected, as shown in Figure 27, representing the typical CMRR over frequency with internal and external references.

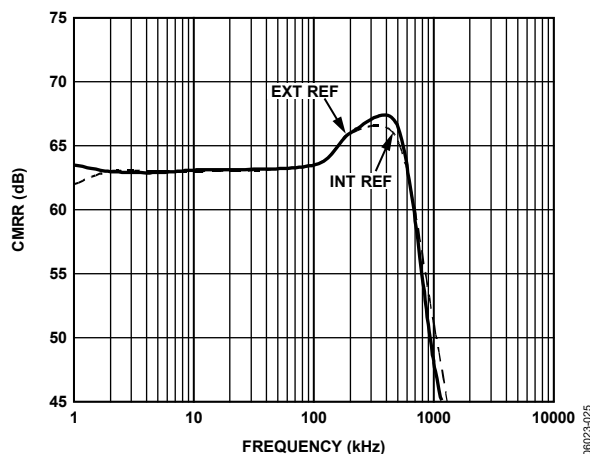

Figure 27. Analog Input CMRR vs. Frequency

During the acquisition phase for ac signals, the impedance of the analog inputs, $IN+$ and $IN-$, can be modeled as a parallel combination of capacitor C_{PIN} and the network formed by the series connection of R_{IN} and C_{IN} . C_{PIN} is primarily the pin capacitance. R_{IN} is typically $175\ \Omega$ and is a lumped component

comprised of some serial resistors and the on resistance of the switches. C_{IN} is typically 12 pF and is mainly the ADC sampling capacitor. During the conversion phase, when the switches are opened, the input impedance is limited to C_{PIN} . R_{IN} and C_{IN} make a 1-pole, low-pass filter that has a typical -3 dB cutoff frequency of 50 MHz, thereby reducing an undesirable aliasing effect and limiting the noise coming from the inputs.

Because the input impedance of the AD7622 is very high, the AD7622 can be directly driven by a low impedance source without gain error. To further improve the noise filtering achieved by the AD7622's analog input circuit, an external 1-pole RC filter between the amplifier's outputs and the ADC analog inputs can be used, as shown in Figure 25. However, large source impedances significantly affect the ac performance, especially the total harmonic distortion (THD). The maximum source impedance depends on the amount of THD that can be tolerated. The THD degrades as a function of the source impedance and the maximum input frequency, as shown in Figure 28.

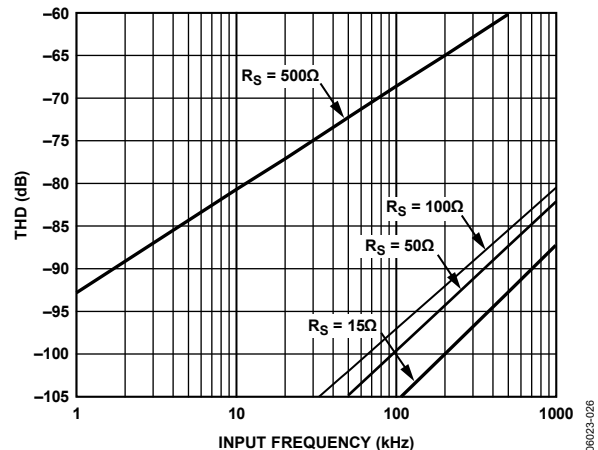

Figure 28. THD vs. Analog Input Frequency and Source Resistance

MULTIPLEXED INPUTS

When using the full 2 MSPS throughput in multiplexed applications for a full-scale step, the RC filter, as shown in Figure 25, does not settle in the required acquisition time, t_s . These values are chosen to optimize the best SNR performance of the AD7622. To use the full 2 MSPS throughput in multiplexed applications, the RC should be adjusted to satisfy t_s (which is $\sim 7 \times RC$ time constant). However, lowering R and C increases the RC filter bandwidth and allows more noise into the AD7622, which degrades SNR. To preserve the SNR performance in these applications using the RC filter shown in Figure 25, the AD7622 should be run with $t_s > 280$ ns; or approximately $1/(t_r + t_s) \sim 1.55$ MSPS in wideband and warp modes.

DRIVER AMPLIFIER CHOICE

Although the AD7622 is easy to drive, the driver amplifier needs to meet the following requirements:

- For multichannel, multiplexed applications, the driver amplifier and the AD7622 analog input circuit must be able to settle for a full-scale step of the capacitor array at an 16-bit level (0.0015%). In the amplifier's data sheet, settling at 0.1% to 0.01% is more commonly specified. This could differ significantly from the settling time at a 16-bit level and should be verified prior to driver selection. The [AD8021](#) op amp, which combines ultralow noise and high gain bandwidth, meets this settling time requirement even when used with gains up to 13.
- The noise generated by the driver amplifier needs to be kept as low as possible to preserve the SNR and transition noise performance of the AD7622. The noise coming from the driver is filtered by the AD7622 analog input circuit 1-pole, low-pass filter made by R_{IN} and C_{IN} or by the external filter, if one is used. The SNR degradation due to the amplifier is

$$SNR_{LOSS} = 20 \log \left(\frac{45}{\sqrt{45^2 + \frac{\pi f_{-3dB}}{2} (Ne_{N+})^2 + \frac{\pi f_{-3dB}}{2} (Ne_{N-})^2}} \right)$$

where:

f_{-3dB} is the input bandwidth of the AD7622 (50 MHz) or the cutoff frequency of the input RC filter shown in Figure 25 (3.9 MHz), if one is used.

N is the noise factor of the amplifier (1 in buffer configuration).

e_{N+} and e_{N-} are the equivalent input voltage noise densities of the op amps connected to $IN+$ and $IN-$, in nV/\sqrt{Hz} . This approximation can be used when the resistances used around the amplifier are small. If larger resistances are used, their noise contributions should also be root-sum squared.

For instance, when using op amps with an equivalent input noise density of $2.1 nV/\sqrt{Hz}$, such as the [AD8021](#), with a noise gain of 1 when configured as a buffer, degrades the SNR by only 0.1 dB when using the RC filter in Figure 25, and by 1.3 dB without it.

- The driver needs to have a THD performance suitable to that of the AD7622. Figure 15 gives the THD vs. frequency that the driver should exceed.

The [AD8021](#) meets these requirements and is appropriate for almost all applications. The [AD8021](#) needs a 10 pF external compensation capacitor that should have good linearity as an NPO ceramic or mica type. Moreover, the use of a noninverting 1 gain arrangement is recommended and helps to obtain the best signal-to-noise ratio.

The [AD8022](#) can also be used when a dual version is needed and a gain of 1 is present. The [AD829](#) is an alternative in applications where high frequency (above 100 kHz) performance is not required. In applications with a gain of 1, an 82 pF compensation capacitor is required. The [AD8610](#) is an option when low bias current is needed in low frequency applications.

Refer to Table 8 for some recommended op amps.

Table 8. Recommended Driver Amplifiers

Amplifier	Typical Application
ADA4841-x	Very low noise, low distortion, low power, low frequency
AD829	Very low noise, low frequency
AD8021	Very low noise, high frequency
AD8022	Very low noise, high frequency, dual
AD8610/AD8620	Low bias current, low frequency, single/dual

Single-to-Differential Driver

For applications using unipolar analog signals, a single-ended-to-differential driver, as shown in Figure 29, allows for a differential input into the part. This configuration, when provided an input signal of 0 to V_{REF} , produces a differential $\pm V_{REF}$ with midscale at $V_{REF}/2$. The 1-pole filter using $R = 15 \Omega$ and $C = 2.7 nF$ provides a corner frequency of 3.9 MHz.

If the application can tolerate more noise, the [AD8139](#) differential driver can be used.

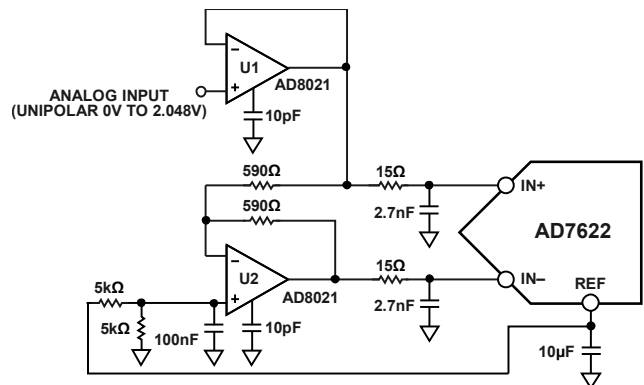

Figure 29. Single-Ended-to-Differential Driver Circuit (Internal Reference Buffer Used)

VOLTAGE REFERENCE INPUT

The AD7622 allows the choice of either a very low temperature drift internal voltage reference, an external 1.2 V reference that can be buffered using the internal reference buffer, or an external reference.

Unlike many ADCs with internal references, the internal reference of the AD7622 provides excellent performance and can be used in almost all applications.

Internal Reference (PDBUF = Low, PDREF = Low)

To use the internal reference, the PDREF and PDBUF inputs must both be low. This produces a 1.2 V band gap output on REFBUFIN, which is amplified by the internal buffer and results in a 2.048 V reference on the REF pin.

The internal reference is temperature compensated to 2.048 V \pm 10 mV. The reference is trimmed to provide a typical drift of 8 ppm/ $^{\circ}$ C. This typical drift characteristic is shown in Figure 9.

The output resistance of REFBUFIN is 6.33 k Ω (minimum) when the internal reference is enabled. It is necessary to decouple this with a ceramic capacitor greater than 100 nF. Therefore, the capacitor provides an RC filter for noise reduction.

Because the output impedance of REFBUFIN is typically 6.33 k Ω , relative humidity (among other industrial contaminants) can directly affect the drift characteristics of the reference. Typically, a guard ring is used to reduce the effects of drift under such circumstances. However, because the AD7622 has a fine lead pitch, guarding this node is not practical. Therefore, in these industrial and other types of applications, it is recommended to use a conformal coating, such as Dow Corning® 1-2577 or HumiSeal® 1B73.

External 1.2 V Reference and Internal Buffer (PDBUF = Low, PDREF = High)

To use an external reference along with the internal buffer, PDREF should be high and PDBUF should be low. This powers down the internal reference and allows an external 1.2 V reference to be applied to REFBUFIN, producing 2.048 V (typically) on the REF pin.

External 2.5 V Reference (PDBUF = High, PDREF = High)

To use an external 2.5 V reference directly on the REF pin, PDREF and PDBUF should both be high.

For improved drift performance, an external reference, such as the [AD780](#), [ADR421](#), [ADR431](#), or [ADR441](#), can be used.

The advantages of directly using the external voltage reference are:

- The SNR and dynamic range improvement (about 1.7 dB) resulting from the use of a reference voltage very close to the supply (2.5 V) instead of a typical 2.048 V reference when the internal reference is used. This is calculated by

$$SNR = 20\log\left(\frac{2.048}{2.50}\right)$$

- The power savings when the internal reference is powered down (PDREF high).

PDREF and PDBUF power down the internal reference and the internal reference buffer, respectively. The input current of PDREF and PDBUF should never exceed 20 mA. This can occur when the driving voltage is above AVDD (for instance, at power-up). In this case, a 125 Ω series resistor is recommended.

Reference Decoupling

Whether using an internal or external reference, the AD7622 voltage reference input (REF) has a dynamic input impedance; therefore, it should be driven by a low impedance source with efficient decoupling between the REF and REFGND inputs. This decoupling depends on the choice of the voltage reference but usually consists of a low ESR capacitor connected to REF and REFGND with minimum parasitic inductance. A 10 μ F (X5R, 1206 size) ceramic chip capacitor (or 47 μ F tantalum capacitor) is appropriate when using either the internal reference or one of the recommended reference voltages.

The placement of the reference decoupling is also important to the performance of the AD7622. The decoupling capacitor should be mounted on the same side as the ADC right at the REF pin with a thick PCB trace. The REFGND should also connect to the reference decoupling capacitor with the shortest distance.

For applications that use multiple AD7622 devices, it is more effective to use an external reference with the internal reference buffer to buffer the reference voltage. However, because the reference buffers are not unity gain, ratiometric, simultaneously sampled designs should use an external reference and external buffer, such as the [AD8031/AD8032](#); therefore, preserving the same reference level for all converters.

The voltage reference temperature coefficient (TC) directly impacts full scale; therefore, in applications where full-scale accuracy matters, care must be taken with the TC. For instance, a \pm 15 ppm/ $^{\circ}$ C TC of the reference changes full scale by \pm 1 LSB/ $^{\circ}$ C.

Note that V_{REF} can be increased to AVDD + 0.1 V. Because the input range is defined in terms of V_{REF} , this would essentially increase the range to 0 V to 2.8 V with an AVDD = 2.7 V.

Temperature Sensor

The TEMP pin measures the temperature of the AD7622. To improve the calibration accuracy over the temperature range, the output of the TEMP pin is applied to one of the inputs of the analog switch (such as, ADG779), and the ADC itself is used to measure its own temperature. This configuration is shown in Figure 30.

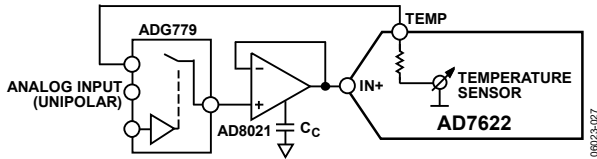

Figure 30. Use of the Temperature Sensor

POWER SUPPLY

The AD7622 uses three sets of power supply pins: an analog 2.5 V supply AVDD, a digital 2.5 V core supply DVDD, and a digital input/output interface supply OVDD. The OVDD supply allows direct interface with any logic working between 2.3 V and 5.25 V. To reduce the number of supplies needed, the digital core (DVDD) can be supplied through a simple RC filter from the analog supply, as shown in Figure 25.

Power Sequencing

The AD7622 is independent of power supply sequencing and thus free from supply induced voltage latch-up. In addition, it is very insensitive to power supply variations over a wide frequency range, as shown in Figure 31.

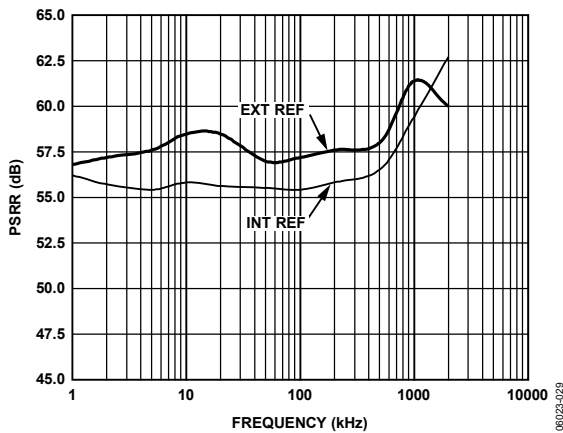

Figure 31. PSRR vs. Frequency

Power-Up

At power-up, or when returning to operational mode from the power-down mode (PD = high), the AD7622 engages an initialization process. During this time, the first 128 conversions should be ignored or the RESET input could be pulsed to engage a faster initialization process. Refer to the Digital Interface section for RESET and timing details.

A simple power-on reset circuit, as shown in Figure 25, can be used to minimize the digital interface. As OVDD powers up, the capacitor is shorted and brings RESET high; it is then charged returning RESET to low. However, this circuit only works when powering up the AD7622 because the power-down mode (PD = high) does not power down any of the supplies and as a result, RESET is low.

It should be noted that the digital interface remains active even during the acquisition phase. To reduce the operating digital supply currents even further, drive the digital inputs close to the power rails (that is, OVDD and OGND).

CONVERSION CONTROL

The AD7622 is controlled by the $\overline{\text{CNVST}}$ input. A falling edge on $\overline{\text{CNVST}}$ is all that is necessary to initiate a conversion. Detailed timing diagrams of the conversion process are shown in Figure 32. Once initiated, it cannot be restarted or aborted, even by the power-down input, PD, until the conversion is complete. The $\overline{\text{CNVST}}$ signal operates independently of $\overline{\text{CS}}$ and $\overline{\text{RD}}$ signals.

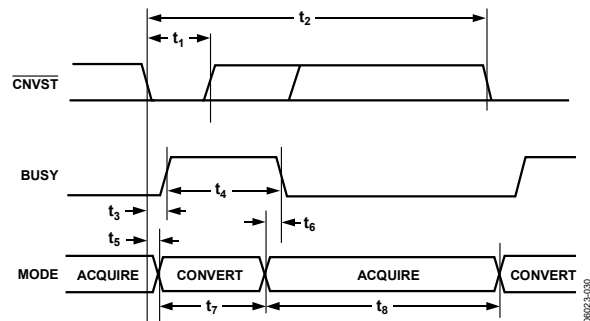

Figure 32. Basic Conversion Timing

For optimal performance, the rising edge of $\overline{\text{CNVST}}$ should not occur after the maximum $\overline{\text{CNVST}}$ low time, t_1 , or until the end of conversion.

Although $\overline{\text{CNVST}}$ is a digital signal, it should be designed with special care with fast, clean edges and levels with minimum overshoot and undershoot or ringing.

The $\overline{\text{CNVST}}$ trace should be shielded with ground and a low value serial resistor (for example, 50 Ω) termination should be added close to the output of the component that drives this line. In addition, a 50 pF capacitor is recommended to further reduce the effects of overshoot and undershoot as shown in Figure 25.

For applications where SNR is critical, the $\overline{\text{CNVST}}$ signal should have very low jitter. This can be achieved by using a dedicated oscillator for $\overline{\text{CNVST}}$ generation, or by clocking $\overline{\text{CNVST}}$ with a high frequency, low jitter clock, as shown in Figure 25.

INTERFACES

DIGITAL INTERFACE

The AD7622 has a versatile digital interface that can be set up as either a serial or a parallel interface with the host system. The serial interface is multiplexed on the parallel data bus. The AD7622 digital interface also accommodates 2.5 V, 3.3 V, or 5 V logic with either OVDD at 2.5 V or 3.3 V. OVDD defines the logic high output voltage. In most applications, the OVDD supply pin of the AD7622 is connected to the host system interface 2.5 V or 3.3 V digital supply. By using the $\overline{OB}/2\overline{C}$ input pin, either twos complement or straight binary coding can be used.

The two signals \overline{CS} and \overline{RD} control the interface. When at least one of these signals is high, the interface outputs are in high impedance. Usually, \overline{CS} allows the selection of each AD7622 in multicircuit applications and is held low in a single AD7622 design. \overline{RD} is generally used to enable the conversion result on the data bus.

RESET

The RESET input is used to reset the AD7622 and generate a fast initialization. A rising edge on RESET aborts the current conversion (if any) and tristates the data bus. The falling edge of RESET clears the data bus and engages the initialization process indicated by pulsing BUSY high. Conversions can take place after the falling edge of BUSY. Refer to Figure 33 for the RESET timing details.

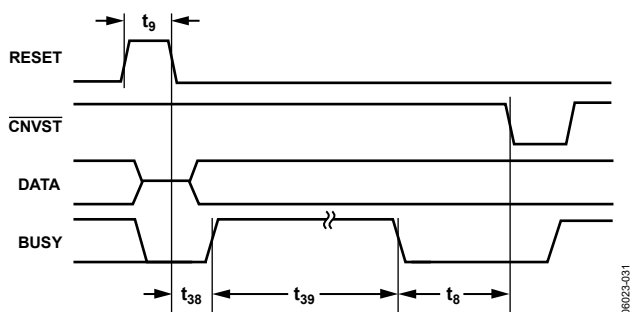

Figure 33. RESET Timing

PARALLEL INTERFACE

The AD7622 is configured to use the parallel interface when $\overline{SER}/\overline{PAR}$ is held low.

Master Parallel Interface

Data can be continuously read by tying \overline{CS} and \overline{RD} low, thus requiring minimal microprocessor connections. However, in this mode, the data bus is always driven and cannot be used in shared bus applications, unless the device is held in RESET. Figure 34 details the timing for this mode.

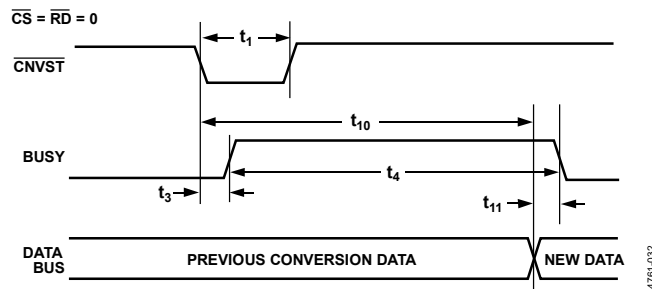

Figure 34. Master Parallel Data Timing for Reading (Continuous Read)

Slave Parallel Interface

In slave parallel reading mode, the data can be read either after each conversion, which is during the next acquisition phase, or during the following conversion, as shown in Figure 35 and Figure 36, respectively. When the data is read during the conversion, it is recommended that it is read-only during the first half of the conversion phase. This avoids any potential feedthrough between voltage transients on the digital interface and the most critical analog conversion circuitry.

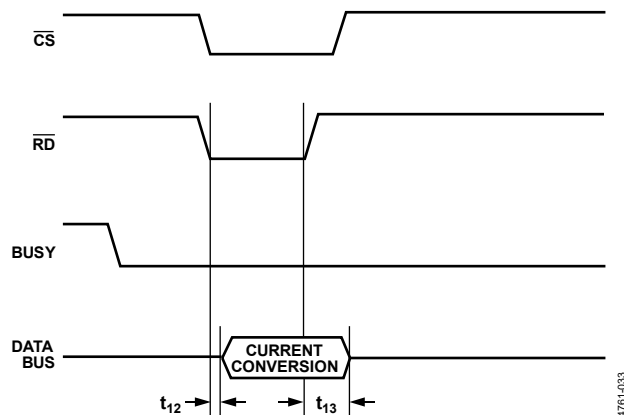

Figure 35. Slave Parallel Data Timing for Reading (Read After Convert)

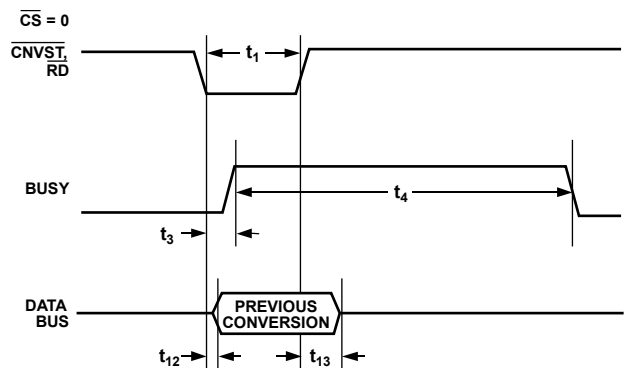

Figure 36. Slave Parallel Data Timing for Reading (Read During Convert)

8-Bit Interface (Master or Slave)

The BYTESWAP pin allows a glueless interface to an 8-bit bus. As shown in Figure 37, when BYTESWAP is low, the LSB byte is output on D[7:0] and the MSB is output on D[15:8]. When BYTESWAP is high, the LSB and MSB bytes are swapped, and the LSB is output on D[15:8] and the MSB is output on D[7:0]. By connecting BYTESWAP to an address line, the 16-bit data can be read in two bytes on either D[15:8] or D[7:0]. This interface can be used in both master and slave parallel reading modes.

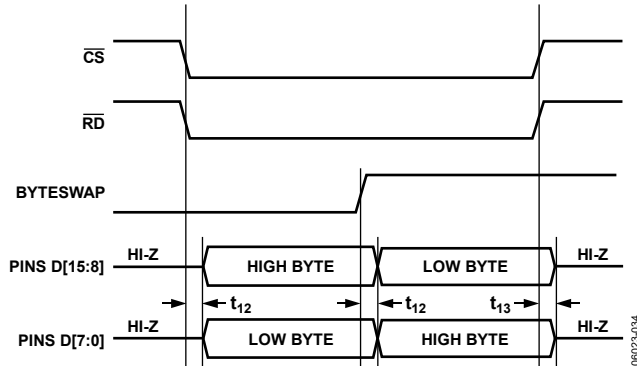

Figure 37. 8-Bit and 16-Bit Parallel Interface

SERIAL INTERFACE

The AD7622 is configured to use the serial interface when SER/ \overline{PAR} = high. The AD7622 outputs 16 bits of data, MSB first, on the SDOUT pin. This data is synchronized with the 16 clock pulses provided on the SCLK pin. The output data is valid on both the rising and falling edge of the data clock.

MASTER SERIAL INTERFACE

Internal Clock

The AD7622 is configured to generate and provide the serial data clock SCLK when the EXT/ \overline{INT} pin = low. The AD7622 also generates a SYNC signal to indicate to the host when the serial data is valid. The serial clock SCLK and the SYNC signal can be inverted. Depending on the state of the read during convert input, RDC/SDIN, the data can be read after each conversion or during the following conversion. Figure 38 and Figure 39 show detailed timing diagrams of these two modes.

Usually, because the AD7622 is used with a fast throughput, the master read during conversion mode, RDC/SDIN = high, is the most recommended serial mode. In this mode, the serial clock and data toggle at appropriate instants, minimizing potential feedthrough between digital activity and critical conversion decisions. In this mode, the SCLK period changes because the LSBs require more time to settle and the SCLK is derived from the SAR conversion cycle.

In read after conversion mode, RDC/SDIN = low, it should be noted that unlike other modes, the BUSY signal returns low after the 16 data bits are pulsed out and not at the end of the conversion phase, resulting in a longer BUSY width. As a result, the maximum throughput cannot be achieved in this mode.

In addition, in read after convert mode, the SCLK frequency can be slowed down to accommodate different hosts using the DIVSCLK[1:0] inputs. Refer to Table 4 for the SCLK timing details when using these inputs.

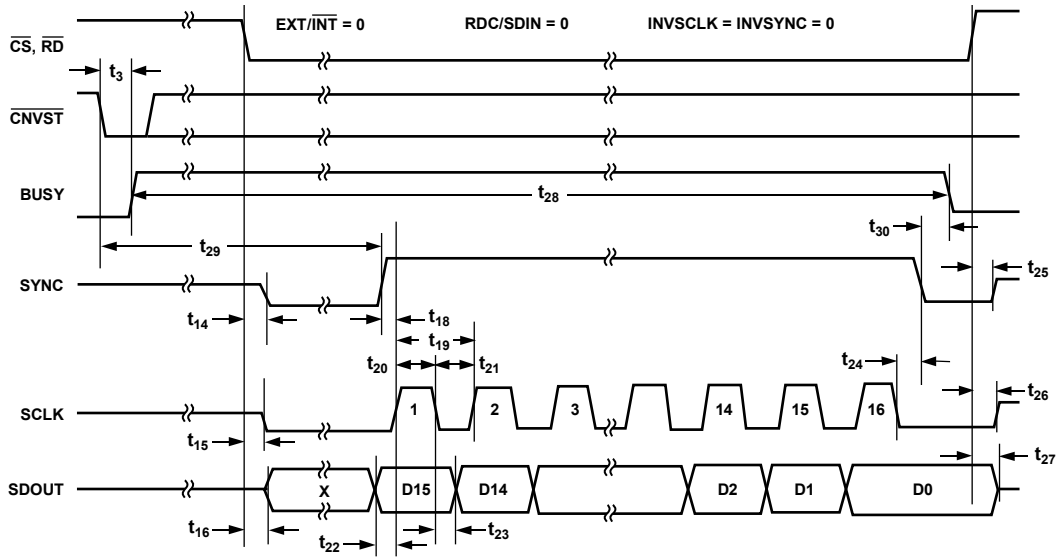

Figure 38. Master Serial Data Timing for Reading (Read After Convert)

06023-035

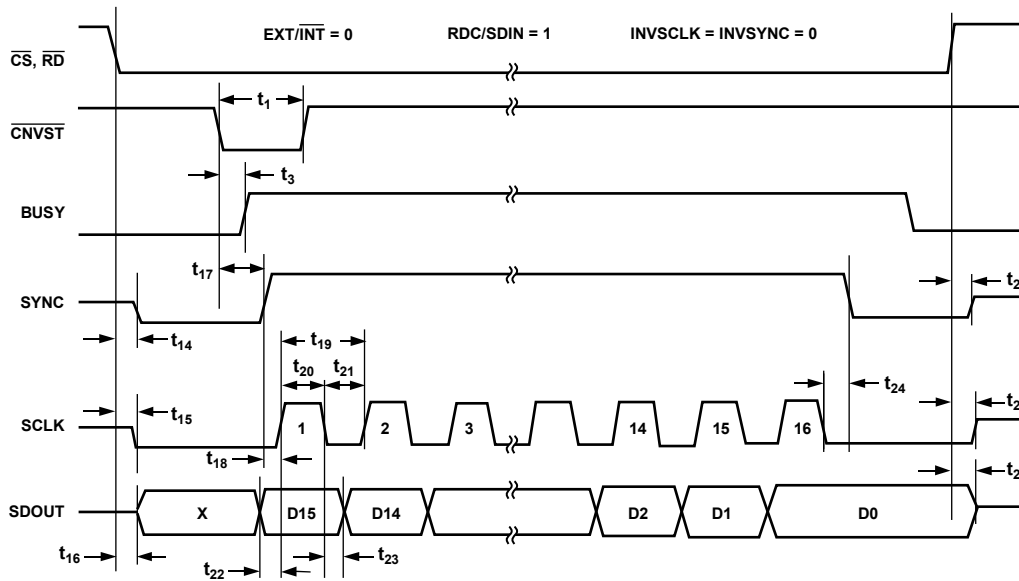

Figure 39. Master Serial Data Timing for Reading (Read Previous Conversion During Convert)

06023-036

SLAVE SERIAL INTERFACE

External Clock

The AD7622 is configured to accept an externally supplied serial data clock on the SCLK pin when the EXT/INT pin is held high. In this mode, several methods can be used to read the data. The external serial clock is gated by \overline{CS} . When \overline{CS} and \overline{RD} are both low, the data can be read after each conversion or during the following conversion. The external clock can be either a continuous or a discontinuous clock. A discontinuous clock can be either normally high or normally low when inactive. Figure 41 and Figure 42 show the detailed timing diagrams of these methods.

While the AD7622 is performing a bit decision, it is important that voltage transients be avoided on digital input/output pins or degradation of the conversion result could occur. This is particularly important during the second half of the conversion phase because the AD7622 provides error correction circuitry that can correct for an improper bit decision made during the first half of the conversion phase. For this reason, it is recommended that when an external clock is being provided, a discontinuous clock is toggled only when BUSY is low or, more importantly, that it does not transition during the latter half of BUSY high.

External Discontinuous Clock Data Read After Conversion

Though the maximum throughput cannot be achieved using this mode, it is the most recommended of the serial slave modes. Figure 41 shows the detailed timing diagrams of this method. After a conversion is complete, indicated by BUSY returning low, the conversion result can be read while both \overline{CS} and \overline{RD} are low. Data is shifted out MSB first with 16 clock pulses and is valid on the rising and falling edges of the clock.

Among the advantages of this method is the fact that conversion performance is not degraded because there are no voltage transients on the digital interface during the conversion process. Another advantage is the ability to read the data at any speed up to 80 MHz, which accommodates both the slow digital host interface and the fast serial reading.

It is also possible to begin to read data after conversion and continue to read the last bits after a new conversion is initiated. In this reading mode, it is recommended to pause digital activity just prior to initiating a conversion (SCLK should be held high or low). Once the conversion has begun, the reading can continue. In addition, in this mode, the use of a slower clock speed can be used to read the data because the total reading time is the acquisition time, t_s + half of the conversion time, t_7 ($t_s + \frac{1}{2} \times t_7$, see the External Clock Data Read During Previous Conversion section).

Finally, in this mode only, the AD7622 provides a daisy-chain feature using the RDC/SDIN pin for cascading multiple converters together. This feature is useful for reducing component count and wiring connections when desired, as, for instance, in isolated multiconverter applications.

An example of the concatenation of two devices is shown in Figure 40. Simultaneous sampling is possible by using a common CNVST signal. It should be noted that the RDC/SDIN input is latched on the edge of SCLK opposite to the one used to shift out the data on SDOUT. Therefore, the MSB of the upstream converter just follows the LSB of the downstream converter on the next SCLK cycle.

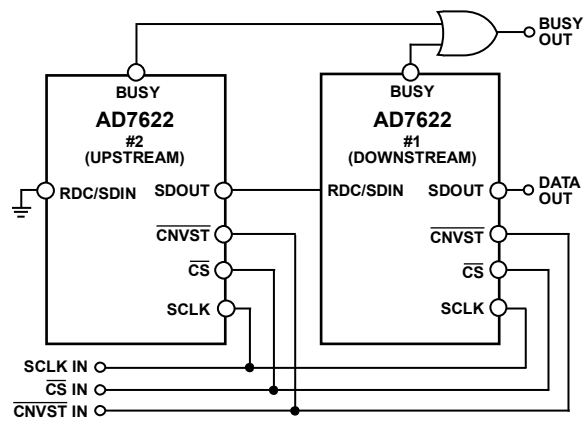

Figure 40. Two AD7622 Devices in a Daisy-Chain Configuration

External Clock Data Read During Previous Conversion

Figure 42 shows the detailed timing diagrams of this method. During a conversion, while \overline{CS} and \overline{RD} are both low, the result of the previous conversion can be read. The data is shifted out, MSB first, with 16 clock pulses and is valid on both the rising and falling edge of the clock. The 16 bits have to be read before the current conversion is complete; otherwise, RDERROR is pulsed high and can be used to interrupt the host interface to prevent incomplete data reading. There is no daisy-chain feature in this mode, and the RDC/SDIN input should always be tied either high or low.

To reduce performance degradation due to digital activity, a fast discontinuous clock (at least 60 MHz when normal mode is used, or 80 MHz when warp mode is used) is recommended to ensure that all the bits are read during the first half of the SAR conversion phase.

If the maximum throughput is not used, thus allowing more acquisition time, then the use of a slower clock speed can be used to read the data.

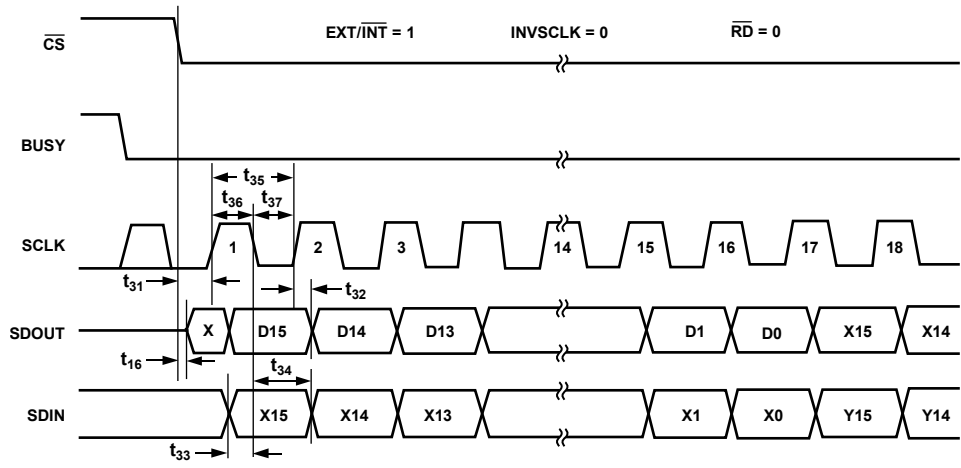

Figure 41. Slave Serial Data Timing for Reading (Read After Convert)

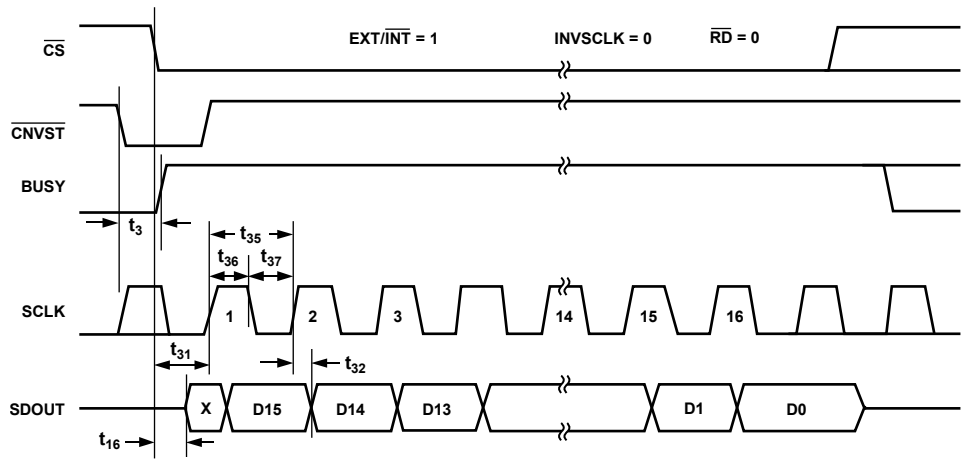

Figure 42. Slave Serial Data Timing for Reading (Read Previous Conversion During Convert)

AD7622

MICROPROCESSOR INTERFACING

The AD7622 is ideally suited for traditional dc measurement applications supporting a microprocessor, and ac signal processing applications interfacing to a digital signal processor. The AD7622 is designed to interface with a parallel 8-bit or 16-bit wide interface or with a general-purpose serial port or I/O ports on a microcontroller. A variety of external buffers can be used with the AD7622 to prevent digital noise from coupling into the ADC. The SPI Interface (ADSP-219x) section illustrates the use of the AD7622 with the ADSP-219x SPI-equipped DSP.

SPI Interface (ADSP-219x)

Figure 43 shows an interface diagram between the AD7622 and an SPI-equipped DSP, the ADSP-219x. To accommodate the slower speed of the DSP, the AD7622 acts as a slave device and data must be read after conversion. This mode also allows the daisy-chain feature. The convert command can be initiated in response to an internal timer interrupt. The 16-bit output data are read with three SPI byte access. The reading process can be initiated in response to the end-of-conversion signal (BUSY going low) using an interrupt line of the DSP. The serial peripheral interface (SPI) on the ADSP-219x is configured for master mode (MSTR) = 1, clock polarity bit (CPOL) = 0, clock phase bit (CPHA) = 1, and the SPI interrupt enable (TIMOD) = 00 by writing to the SPI control register (SPICLTx). It should be noted that to meet all timing requirements, the SPI clock should be limited to 17 Mbps, allowing it to read an ADC result in less than 1 μ s. When a higher sampling rate is desired, it is recommended to use one of the parallel interface modes.

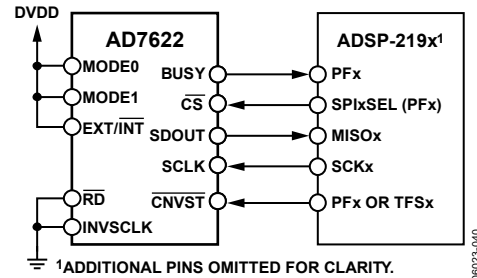

Figure 43. Interfacing the AD7622 to ADSP-219x

APPLICATION HINTS

LAYOUT

While the AD7622 has very good immunity to noise on the power supplies, exercise care with the grounding layout. To facilitate the use of ground planes that can be easily separated, design the printed circuit board that houses the AD7622 so that the analog and digital sections are separated and confined to certain areas of the board. Digital and analog ground planes should be joined in only one place, preferably underneath the AD7622, or as close as possible to the AD7622. If the AD7622 is in a system where multiple devices require analog-to-digital ground connections, the connections should still be made at one point only, a star ground point, established as close as possible to the AD7622.

To prevent coupling noise onto the die, avoid radiating noise, and reduce feedthrough:

- Do not run digital lines under the device.
- Run the analog ground plane under the AD7622.
- Shield fast switching signals, like $\overline{\text{CNVST}}$ or clocks, with digital ground to avoid radiating noise to other sections of the board, and never run them near analog signal paths.
- Avoid crossover of digital and analog signals.
- Run traces on different but close layers of the board, at right angles to each other, to reduce the effect of feedthrough through the board.

The power supply lines to the AD7622 should use as large a trace as possible to provide low impedance paths and reduce the effect of glitches on the power supply lines. Good decoupling is also important to lower the impedance of the supplies presented to the AD7622, and to reduce the magnitude of the supply spikes. Decoupling ceramic capacitors, typically 100 nF, should be placed on each of the power supplies pins, AVDD, DVDD, and OVDD. The capacitors should be placed close to, and ideally right up against, these pins and their corresponding ground pins. Additionally, low ESR 10 μF capacitors should be located in the vicinity of the ADC to further reduce low frequency ripple.

The DVDD supply of the AD7622 can be either a separate supply or come from the analog supply, AVDD, or from the digital interface supply, OVDD. When the system digital supply is noisy, or fast switching digital signals are present, and no separate supply is available, it is recommended to connect the DVDD digital supply to the analog supply AVDD through an RC filter, and to connect the system supply to the interface digital supply OVDD and the remaining digital circuitry. Refer to Figure 25 for an example of this configuration. When DVDD is powered from the system supply, it is useful to insert a bead to further reduce high frequency spikes.

The AD7622 has four different ground pins: REFGND, AGND, DGND, and OGND. REFGND senses the reference voltage and, because it carries pulsed currents, should have a low impedance return to the reference. AGND is the ground to which most internal ADC analog signals are referenced; it must be connected with the least resistance to the analog ground plane. DGND must be tied to the analog or digital ground plane depending on the configuration. OGND is connected to the digital system ground.

The layout of the decoupling of the reference voltage is important. To minimize parasitic inductances, place the decoupling capacitor close to the ADC and connect it with short, thick traces.

EVALUATING THE AD7622 PERFORMANCE

A recommended layout for the AD7622 is outlined in the documentation of the [EVAL-AD7622-CB](#) evaluation board for the AD7622. The evaluation board package includes a fully assembled and tested evaluation board, documentation, and software for controlling the board from a PC via the [EVAL-CONTROL BRD3](#).

OUTLINE DIMENSIONS

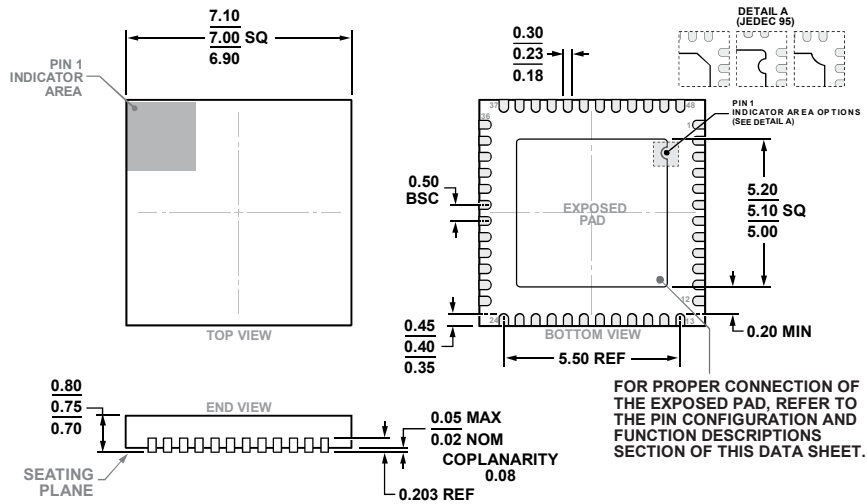

COMPLIANT TO JEDEC STANDARDS MO-220-WKGD-4

Figure 44. 48-Lead Lead Frame Chip Scale Package [LFCSPP]
7 mm × 7 mm Body and 0.75 mm Package Height
(CP-48-4)

Dimensions shown in millimeters

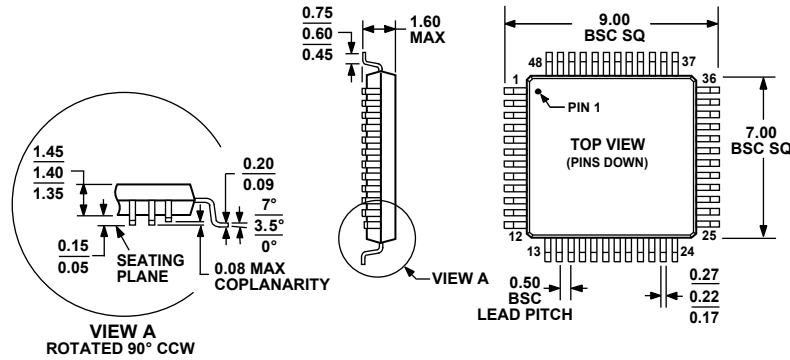

COMPLIANT TO JEDEC STANDARDS MS-026-BBC

Figure 45. 48-Lead Low Profile Quad Flat Package [LQFP]
(ST-48)

Dimensions shown in millimeters

ORDERING GUIDE

Model	Temperature Range	Package Description	Package Option
AD7622BCPZ ¹	-40°C to +85°C	48-Lead Lead Frame Chip Scale Package (LFCSPP)	CP-48-4
AD7622BCPZRL ¹	-40°C to +85°C	48-Lead Lead Frame Chip Scale Package (LFCSPP)	CP-48-4
AD7622BSTZ ¹	-40°C to +85°C	48-Lead Low Profile Quad Flat Package (LQFP)	ST-48
AD7622BSTZRL ¹	-40°C to +85°C	48-Lead Low Profile Quad Flat Package (LQFP)	ST-48
EVAL-AD7622CB ²		Evaluation Board	
EVAL-CONTROL BRD3 ³		Controller Board	

¹ Z = Pb-free part.

² This board can be used as a standalone evaluation board or in conjunction with the EVAL-CONTROL BRD3 for evaluation/demonstration purposes.

³ This board allows a PC to control and communicate with all Analog Devices, Inc. evaluation boards ending in the CB designators.

Looking for pricing, stock, or lifecycle information?

Click below to explore more details on WIN SOURCE:

 [View AD7622BCPZ on WIN SOURCE](#)

 [Analog Devices Inc. Information](#)

Optimize Your Supply Chain with WIN SOURCE Solutions

-  Global Sourcing Solution
-  Obsolete Management
-  Cost Control Management
-  Shortage Management
-  Alternative Solution
-  Excess Inventory Management