



**THE DATASHEET OF
A3PE3000-FG896I**



ProASIC3E Flash Family FPGAs with Optional Soft ARM Support

DS0098

Features and Benefits

High Capacity

- 600 k to 3 Million System Gates
- 108 to 504 kbits of True Dual-Port SRAM
- Up to 620 User I/Os

Reprogrammable Flash Technology

- 130-nm, 7-Layer Metal (6 Copper), Flash-Based CMOS Process
- Instant On Level 0 Support
- Single-Chip Solution
- Retains Programmed Design when Powered Off

On-Chip User Nonvolatile Memory

- 1 kbit of FlashROM with Synchronous Interfacing

High Performance

- 350 MHz System Performance
- 3.3 V, 66 MHz 64-Bit PCI

In-System Programming (ISP) and Security

- ISP Using On-Chip 128-Bit Advanced Encryption Standard (AES) Decryption via JTAG (IEEE 1532-compliant)
- FlashLock[®] Designed to Secure FPGA Contents

Low Power

- Core Voltage for Low Power
- Support for 1.5-V-Only Systems
- Low-Impedance Flash Switches

High-Performance Routing Hierarchy

- Segmented, Hierarchical Routing and Clock Structure
- Ultra-Fast Local and Long-Line Network
- Enhanced High-Speed, Very-Long-Line Network
- High-Performance, Low-Skew Global Network
- Architecture Supports Ultra-High Utilization

Pro (Professional) I/O

- 700 Mbps DDR, LVDS-Capable I/Os
- 1.5 V, 1.8 V, 2.5 V, and 3.3 V Mixed-Voltage Operation
- Bank-Selectable I/O Voltages—up to 8 Banks per Chip
- Single-Ended I/O Standards: LVTTTL, LVCMOS 3.3 V / 2.5 V / 1.8 V / 1.5 V, 3.3 V PCI / 3.3 V PCI-X, and LVCMOS 2.5 V / 5.0 V Input
- Differential I/O Standards: LVPECL, LVDS, B-LVDS, and M-LVDS
- Voltage-Referenced I/O Standards: GTL+ 2.5 V / 3.3 V, GTL 2.5 V / 3.3 V, HSTL Class I and II, SSTL2 Class I and II, SSTL3 Class I and II
- I/O Registers on Input, Output, and Enable Paths
- Hot-Swappable and Cold Sparing I/Os
- Programmable Output Slew Rate and Drive Strength
- Programmable Input Delay
- Schmitt Trigger Option on Single-Ended Inputs
- Weak Pull-Up/Down
- IEEE 1149.1 (JTAG) Boundary Scan Test
- Pin-Compatible Packages across the ProASIC[®]3E Family

Clock Conditioning Circuit (CCC) and PLL

- Six CCC Blocks, Each with an Integrated PLL
- Configurable Phase-Shift, Multiply/Divide, Delay Capabilities and External Feedback
- Wide Input Frequency Range (1.5 MHz to 350 MHz)

SRAMs and FIFOs

- Variable-Aspect-Ratio 4,608-Bit RAM Blocks (×1, ×2, ×4, ×9, and ×18 organizations available)
- True Dual-Port SRAM (except ×18)
- 24 SRAM and FIFO Configurations with Synchronous Operation up to 350 MHz

ARM[®] Processor Support in ProASIC3E FPGAs

- M1 ProASIC3E Devices—Cortex-M1 Soft Processor Available with or without Debug

Table 1-1 • ProASIC3E Product Family

ProASIC3E Devices	A3PE600	A3PE1500	A3PE3000
Cortex-M1 Devices ¹		M1A3PE1500	M1A3PE3000
System Gates	600,000	1,500,000	3,000,000
VersaTiles (D-flip-flops)	13,824	38,400	75,264
RAM Kbits (1,024 bits)	108	270	504
4,608-Bit Blocks	24	60	112
FlashROM Kbits	1	1	1
Secure (AES) ISP	Yes	Yes	Yes
CCCs with Integrated PLLs ²	6	6	6
VersaNet Globals ³	18	18	18
I/O Banks	8	8	8
Maximum User I/Os	270	444	620
Package Pins PQFP FBGA	FG256, FG484	PQ208 FG484, FG676	PQ208 FG324, FG484, FG896

Notes:

1. Refer to the [Cortex-M1 product brief](#) for more information.
2. The PQ208 package supports six CCCs and two PLLs.
3. Six chip (main) and three quadrant global networks are available.
4. For devices supporting lower densities, refer to the [ProASIC3 Flash Family FPGAs datasheet](#).

I/Os Per Package¹

ProASIC3E Devices	A3PE600		A3PE1500 ³		A3PE3000 ³	
Cortex-M1 Devices ²			M1A3PE1500		M1A3PE3000	
Package	I/O Types					
	Single-Ended I/O ¹	Differential I/O Pairs	Single-Ended I/O ¹	Differential I/O Pairs	Single-Ended I/O ¹	Differential I/O Pairs
PQ208	–	–	147	65	147	65
FG256	165	79	–	–	–	–
FG324	–	–	–	–	221	110
FG484	270	135	280	139	341	168
FG676	–	–	444	222	–	–
FG896	–	–	–	–	620	310

Notes:

- When considering migrating your design to a lower- or higher-density device, refer to the [ProASIC3E FPGA Fabric User's Guide](#) to ensure compliance with design and board migration requirements.
- Each used differential I/O pair reduces the number of single-ended I/Os available by two.
- For A3PE1500 and A3PE3000 devices, the usage of certain I/O standards is limited as follows:
 - SSTL3(I) and (II): up to 40 I/Os per north or south bank
 - LVPECL / GTL+ 3.3 V / GTL 3.3 V: up to 48 I/Os per north or south bank
 - SSTL2(I) and (II) / GTL+ 2.5 V / GTL 2.5 V: up to 72 I/Os per north or south bank
- FG256 and FG484 are footprint-compatible packages.
- When using voltage-referenced I/O standards, one I/O pin should be assigned as a voltage-referenced pin (VREF) per minibank (group of I/Os).
- "G" indicates RoHS-compliant packages. Refer to the ["ProASIC3E Ordering Information"](#) on page III for the location of the "G" in the part number.

Table 1-2 • ProASIC3E FPGAs Package Sizes Dimensions

Package	PQ208	FG256	FG324	FG484	FG676	FG896
Length × Width (mm\mm)	28 × 28	17 × 17	19 × 19	23 × 23	27 × 27	31 × 31
Nominal Area (mm ²)	784	289	361	529	729	961
Pitch (mm)	0.5	1.0	1.0	1.0	1.0	1.0
Height (mm)	3.40	1.60	1.63	2.23	2.23	2.23

ProASIC3E Device Status

ProASIC3E Devices	Status	M1 ProASIC3E Devices	Status
A3PE600	Production		
A3PE1500	Production	M1A3PE1500	Production
A3PE3000	Production	M1A3PE3000	Production

ProASIC3E Ordering Information

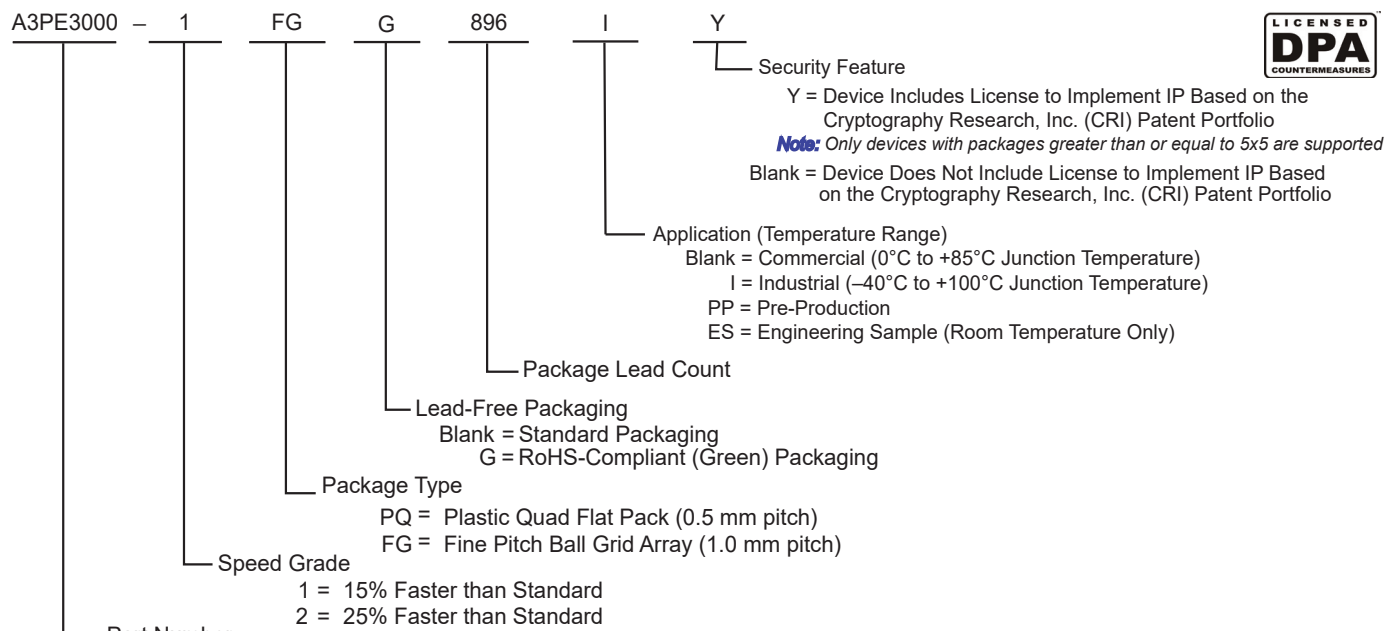

ProASIC3E Devices

- A3PE600 = 600,000 System Gates
- A3PE1500 = 1,500,000 System Gates
- A3PE3000 = 3,000,000 System Gates

ProASIC3E Devices with Cortex-M1

- M1A3PE1500 = 1,500,000 System Gates
- M1A3PE3000 = 3,000,000 System Gates

Temperature Grade Offerings

Package	A3PE600	A3PE1500	A3PE3000
Cortex-M1 Devices		M1A3PE1500	M1A3PE3000
PQ208	–	C, I	C, I
FG256	C, I	–	–
FG324	–	–	C, I
FG484	C, I	C, I	C, I
FG676	–	C, I	–
FG896	–	–	C, I

Note: C = Commercial temperature range: 0°C to 70°C ambient temperature
 I = Industrial temperature range: –40°C to 85°C ambient temperature

Speed Grade and Temperature Grade Matrix

Temperature Grade	Std.	–1	–2
C ¹	✓	✓	✓
I ²	✓	✓	✓

Notes:

1. C = Commercial temperature range: 0°C to 70°C ambient temperature
2. I = Industrial temperature range: –40°C to 85°C ambient temperature

References made to ProASIC3E devices also apply to ARM-enabled ProASIC3E devices. The ARM-enabled part numbers start with M1 (Cortex-M1).

Contact your local Microsemi SoC Products Group representative for device availability:
www.microsemi.com/index.php?option=com_content&id=135&lang=en&view=article.

Table of Contents

ProASIC3E Device Family Overview

General Description	1-1
---------------------------	-----

ProASIC3E DC and Switching Characteristics

General Specifications	2-1
Calculating Power Dissipation	2-6
User I/O Characteristics	2-13
VersaTile Characteristics	2-66
Global Resource Characteristics	2-70
Clock Conditioning Circuits	2-73
Embedded SRAM and FIFO Characteristics	2-75

Pin Descriptions and Packaging

Supply Pins	3-1
User-Defined Supply Pins	3-2
User Pins	3-2
JTAG Pins	3-3
Special Function Pins	3-4
Packaging	3-4
Related Documents	3-4

Package Pin Assignments

PQ208	4-1
FG256	4-6
FG324	4-10
FG484	4-14
FG676	4-30
FG896	4-38

Datasheet Information

List of Changes	5-1
Datasheet Categories	5-12
Safety Critical, Life Support, and High-Reliability Applications Policy	5-12

1 – ProASIC3E Device Family Overview

General Description

ProASIC3E, the third-generation family of Microsemi flash FPGAs, offers performance, density, and features beyond those of the ProASIC^{PLUS}® family. Nonvolatile flash technology gives ProASIC3E devices the advantage of being a secure, low power, single-chip solution that is Instant On. ProASIC3E is reprogrammable and offers time-to-market benefits at an ASIC-level unit cost. These features enable designers to create high-density systems using existing ASIC or FPGA design flows and tools.

ProASIC3E devices offer 1 kbit of on-chip, programmable, nonvolatile FlashROM storage as well as clock conditioning circuitry based on six integrated phase-locked loops (PLLs). ProASIC3E devices have up to three million system gates, supported with up to 504 kbits of true dual-port SRAM and up to 620 user I/Os.

Several ProASIC3E devices support the Cortex-M1 soft IP cores, and the ARM-Enabled devices have Microsemi ordering numbers that begin with M1A3PE.

Flash Advantages

Reduced Cost of Ownership

Advantages to the designer extend beyond low unit cost, performance, and ease of use. Unlike SRAM-based FPGAs, flash-based ProASIC3E devices allow all functionality to be Instant On; no external boot PROM is required. On-board security mechanisms prevent access to all the programming information and enable secure remote updates of the FPGA logic. Designers can perform secure remote in-system reprogramming to support future design iterations and field upgrades with confidence that valuable intellectual property (IP) cannot be compromised or copied. Secure ISP can be performed using the industry-standard AES algorithm. The ProASIC3E family device architecture mitigates the need for ASIC migration at higher user volumes. This makes the ProASIC3E family a cost-effective ASIC replacement solution, especially for applications in the consumer, networking/ communications, computing, and avionics markets.

Security

The nonvolatile, flash-based ProASIC3E devices do not require a boot PROM, so there is no vulnerable external bitstream that can be easily copied. ProASIC3E devices incorporate FlashLock, which provides a unique combination of reprogrammability and design security without external overhead, advantages that only an FPGA with nonvolatile flash programming can offer.

ProASIC3E devices utilize a 128-bit flash-based lock and a separate AES key to provide the highest level of protection in the FPGA industry for programmed intellectual property and configuration data. In addition, all FlashROM data in ProASIC3E devices can be encrypted prior to loading, using the industry-leading AES-128 (FIPS192) bit block cipher encryption standard. The AES standard was adopted by the National Institute of Standards and Technology (NIST) in 2000 and replaces the 1977 DES standard. ProASIC3E devices have a built-in AES decryption engine and a flash-based AES key that make them the most comprehensive programmable logic device security solution available today. ProASIC3E devices with AES-based security provide a high level of protection for secure, remote field updates over public networks such as the Internet, and ensure that valuable IP remains out of the hands of system overbuilders, system cloners, and IP thieves.

Security, built into the FPGA fabric, is an inherent component of the ProASIC3E family. The flash cells are located beneath seven metal layers, and many device design and layout techniques have been used to make invasive attacks extremely difficult. The ProASIC3E family, with FlashLock and AES security, is unique in being highly resistant to both invasive and noninvasive attacks. Your valuable IP is protected with industry-standard security, making remote ISP possible. A ProASIC3E device provides the best available security for programmable logic designs.

Single Chip

Flash-based FPGAs store their configuration information in on-chip flash cells. Once programmed, the configuration data is an inherent part of the FPGA structure, and no external configuration data needs to

be loaded at system power-up (unlike SRAM-based FPGAs). Therefore, flash-based ProASIC3E FPGAs do not require system configuration components such as EEPROMs or microcontrollers to load device configuration data. This reduces bill-of-materials costs and PCB area, and increases security and system reliability.

Instant On

Flash-based ProASIC3E devices support Level 0 of the Instant On classification standard. This feature helps in system component initialization, execution of critical tasks before the processor wakes up, setup and configuration of memory blocks, clock generation, and bus activity management. The Instant On feature of flash-based ProASIC3E devices greatly simplifies total system design and reduces total system cost, often eliminating the need for CPLDs and clock generation PLLs that are used for these purposes in a system. In addition, glitches and brownouts in system power will not corrupt the ProASIC3E device's flash configuration, and unlike SRAM-based FPGAs, the device will not have to be reloaded when system power is restored. This enables the reduction or complete removal of the configuration PROM, expensive voltage monitor, brownout detection, and clock generator devices from the PCB design. Flash-based ProASIC3E devices simplify total system design and reduce cost and design risk while increasing system reliability and improving system initialization time.

Firm Errors

Firm errors occur most commonly when high-energy neutrons, generated in the upper atmosphere, strike a configuration cell of an SRAM FPGA. The energy of the collision can change the state of the configuration cell and thus change the logic, routing, or I/O behavior in an unpredictable way. These errors are impossible to prevent in SRAM FPGAs. The consequence of this type of error can be a complete system failure. Firm errors do not exist in the configuration memory of ProASIC3E flash-based FPGAs. Once it is programmed, the flash cell configuration element of ProASIC3E FPGAs cannot be altered by high-energy neutrons and is therefore immune to them. Recoverable (or soft) errors occur in the user data SRAM of all FPGA devices. These can easily be mitigated by using error detection and correction (EDAC) circuitry built into the FPGA fabric.

Low Power

Flash-based ProASIC3E devices exhibit power characteristics similar to an ASIC, making them an ideal choice for power-sensitive applications. ProASIC3E devices have only a very limited power-on current surge and no high-current transition period, both of which occur on many FPGAs.

ProASIC3E devices also have low dynamic power consumption to further maximize power savings.

Advanced Flash Technology

The ProASIC3E family offers many benefits, including nonvolatility and reprogrammability through an advanced flash-based, 130-nm LVCMOS process with seven layers of metal. Standard CMOS design techniques are used to implement logic and control functions. The combination of fine granularity, enhanced flexible routing resources, and abundant flash switches allows for very high logic utilization without compromising device routability or performance. Logic functions within the device are interconnected through a four-level routing hierarchy.

Advanced Architecture

The proprietary ProASIC3E architecture provides granularity comparable to standard-cell ASICs. The ProASIC3E device consists of five distinct and programmable architectural features (Figure 1-1 on page 3):

- FPGA VersaTiles
- Dedicated FlashROM
- Dedicated SRAM/FIFO memory
- Extensive CCCs and PLLs
- Pro I/O structure

The FPGA core consists of a sea of VersaTiles. Each VersaTile can be configured as a three-input logic function, a D-flip-flop (with or without enable), or a latch by programming the appropriate flash switch interconnections. The versatility of the ProASIC3E core tile as either a three-input lookup table (LUT) equivalent or as a D-flip-flop/latch with enable allows for efficient use of the FPGA fabric. The VersaTile capability is unique to the ProASIC family of third-generation architecture Flash FPGAs. VersaTiles are connected with any of the four levels of routing hierarchy. Flash switches are distributed throughout the device to provide nonvolatile, reconfigurable interconnect programming. Maximum core utilization is possible for virtually any design.

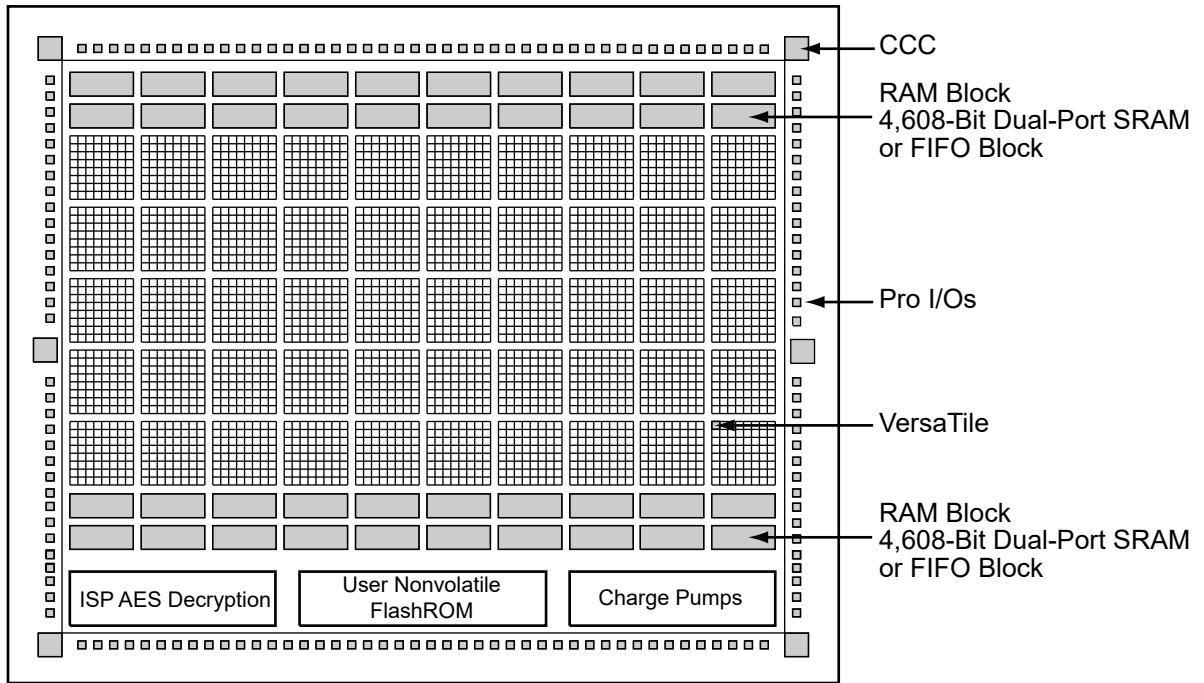

Figure 1-1 • ProASIC3E Device Architecture Overview

VersaTiles

The ProASIC3E core consists of VersaTiles, which have been enhanced beyond the ProASIC^{PLUS}® core tiles. The ProASIC3E VersaTile supports the following:

- All 3-input logic functions—LUT-3 equivalent
- Latch with clear or set
- D-flip-flop with clear or set
- Enable D-flip-flop with clear or set

Refer to [Figure 1-2](#) for VersaTile configurations.

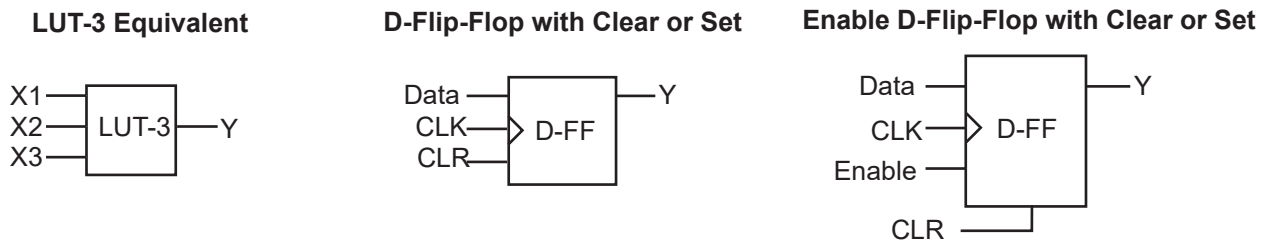

Figure 1-2 • VersaTile Configurations

User Nonvolatile FlashROM

ProASIC3E devices have 1 kbit of on-chip, user-accessible, nonvolatile FlashROM. The FlashROM can be used in diverse system applications:

- Internet protocol addressing (wireless or fixed)
- System calibration settings
- Device serialization and/or inventory control
- Subscription-based business models (for example, set-top boxes)
- Secure key storage for secure communications algorithms
- Asset management/tracking
- Date stamping
- Version management

The FlashROM is written using the standard ProASIC3E IEEE 1532 JTAG programming interface. The core can be individually programmed (erased and written), and on-chip AES decryption can be used selectively to securely load data over public networks, as in security keys stored in the FlashROM for a user design.

The FlashROM can be programmed via the JTAG programming interface, and its contents can be read back either through the JTAG programming interface or via direct FPGA core addressing. Note that the FlashROM can only be programmed from the JTAG interface and cannot be programmed from the internal logic array.

The FlashROM is programmed as 8 banks of 128 bits; however, reading is performed on a byte-by-byte basis using a synchronous interface. A 7-bit address from the FPGA core defines which of the 8 banks and which of the 16 bytes within that bank are being read. The three most significant bits (MSBs) of the FlashROM address determine the bank, and the four least significant bits (LSBs) of the FlashROM address define the byte.

The ProASIC3E development software solutions, Libero[®] System-on-Chip (SoC) and Designer, have extensive support for the FlashROM. One such feature is auto-generation of sequential programming files for applications requiring a unique serial number in each part. Another feature allows the inclusion of static data for system version control. Data for the FlashROM can be generated quickly and easily using Libero SoC and Designer software tools. Comprehensive programming file support is also included to allow for easy programming of large numbers of parts with differing FlashROM contents.

SRAM and FIFO

ProASIC3E devices have embedded SRAM blocks along their north and south sides. Each variable-aspect-ratio SRAM block is 4,608 bits in size. Available memory configurations are 256×18, 512×9, 1k×4, 2k×2, and 4k×1 bits. The individual blocks have independent read and write ports that can be configured with different bit widths on each port.

For example, data can be sent through a 4-bit port and read as a single bitstream. The embedded SRAM blocks can be initialized via the device JTAG port (ROM emulation mode) using the UJTAG macro.

In addition, every SRAM block has an embedded FIFO control unit. The control unit allows the SRAM block to be configured as a synchronous FIFO without using additional core VersaTiles. The FIFO width and depth are programmable. The FIFO also features programmable Almost Empty (AEMPTY) and Almost Full (AFULL) flags in addition to the normal Empty and Full flags. The embedded FIFO control unit contains the counters necessary for generation of the read and write address pointers. The embedded SRAM/FIFO blocks can be cascaded to create larger configurations.

PLL and CCC

ProASIC3E devices provide designers with very flexible clock conditioning capabilities. Each member of the ProASIC3E family contains six CCCs, each with an integrated PLL.

The six CCC blocks are located at the four corners and the centers of the east and west sides.

To maximize user I/Os, only the center east and west PLLs are available in devices using the PQ208 package. However, all six CCC blocks are still usable; the four corner CCCs allow simple clock delay operations as well as clock spine access.

The inputs of the six CCC blocks are accessible from the FPGA core or from one of several inputs located near the CCC that have dedicated connections to the CCC block.

The CCC block has these key features:

- Wide input frequency range (f_{IN_CCC}) = 1.5 MHz to 350 MHz
- Output frequency range (f_{OUT_CCC}) = 0.75 MHz to 350 MHz
- Clock delay adjustment via programmable and fixed delays from -7.56 ns to $+11.12$ ns
- 2 programmable delay types for clock skew minimization
- Clock frequency synthesis

Additional CCC specifications:

- Internal phase shift = 0° , 90° , 180° , and 270° . Output phase shift depends on the output divider configuration.
- Output duty cycle = $50\% \pm 1.5\%$ or better
- Low output jitter: worst case $< 2.5\% \times$ clock period peak-to-peak period jitter when single global network used
- Maximum acquisition time = 300 μ s
- Low power consumption of 5 mW
- Exceptional tolerance to input period jitter— allowable input jitter is up to 1.5 ns
- Four precise phases; maximum misalignment between adjacent phases of 40 ps \times (350 MHz / f_{OUT_CCC})

Global Clocking

ProASIC3E devices have extensive support for multiple clocking domains. In addition to the CCC and PLL support described above, there is a comprehensive global clock distribution network.

Each VersaTile input and output port has access to nine VersaNets: six chip (main) and three quadrant global networks. The VersaNets can be driven by the CCC or directly accessed from the core via multiplexers (MUXes). The VersaNets can be used to distribute low-skew clock signals or for rapid distribution of high fanout nets.

Pro I/Os with Advanced I/O Standards

The ProASIC3E family of FPGAs features a flexible I/O structure, supporting a range of voltages (1.5 V, 1.8 V, 2.5 V, and 3.3 V). ProASIC3E FPGAs support 19 different I/O standards, including single-ended, differential, and voltage-referenced. The I/Os are organized into banks, with eight banks per device (two per side). The configuration of these banks determines the I/O standards supported. Each I/O bank is subdivided into VREF minibanks, which are used by voltage-referenced I/Os. VREF minibanks contain 8 to 18 I/Os. All the I/Os in a given minibank share a common VREF line. Therefore, if any I/O in a given VREF minibank is configured as a VREF pin, the remaining I/Os in that minibank will be able to use that reference voltage.

Each I/O module contains several input, output, and enable registers. These registers allow the implementation of the following:

- Single-Data-Rate applications (e.g., PCI 66 MHz, bidirectional SSTL 2 and 3, Class I and II)
- Double-Data-Rate applications (e.g., DDR LVDS, B-LVDS, and M-LVDS I/Os for point-to-point communications, and DDR 200 MHz SRAM using bidirectional HSTL Class II)

ProASIC3E banks support M-LVDS with 20 multi-drop points.

Hot-swap (also called hot-plug, or hot-insertion) is the operation of hot-insertion or hot-removal of a card in a powered-up system.

Cold-sparing (also called cold-swap) refers to the ability of a device to leave system data undisturbed when the system is powered up, while the component itself is powered down, or when power supplies are floating.

Specifying I/O States During Programming

You can modify the I/O states during programming in FlashPro. In FlashPro, this feature is supported for PDB files generated from Designer v8.5 or greater. See the [FlashPro User's Guide](#) for more information.

Note: PDB files generated from Designer v8.1 to Designer v8.4 (including all service packs) have limited display of Pin Numbers only.

1. Load a PDB from the FlashPro GUI. You must have a PDB loaded to modify the I/O states during programming.
2. From the FlashPro GUI, click PDB Configuration. A FlashPoint – Programming File Generator window appears.
3. Click the Specify I/O States During Programming button to display the Specify I/O States During Programming dialog box.
4. Sort the pins as desired by clicking any of the column headers to sort the entries by that header. Select the I/Os you wish to modify ([Figure 1-3 on page 1-7](#)).
5. Set the I/O Output State. You can set Basic I/O settings if you want to use the default I/O settings for your pins, or use Custom I/O settings to customize the settings for each pin. Basic I/O state settings:
 - 1 – I/O is set to drive out logic High
 - 0 – I/O is set to drive out logic Low
 - Last Known State – I/O is set to the last value that was driven out prior to entering the programming mode, and then held at that value during programming
 - Z -Tri-State: I/O is tristated

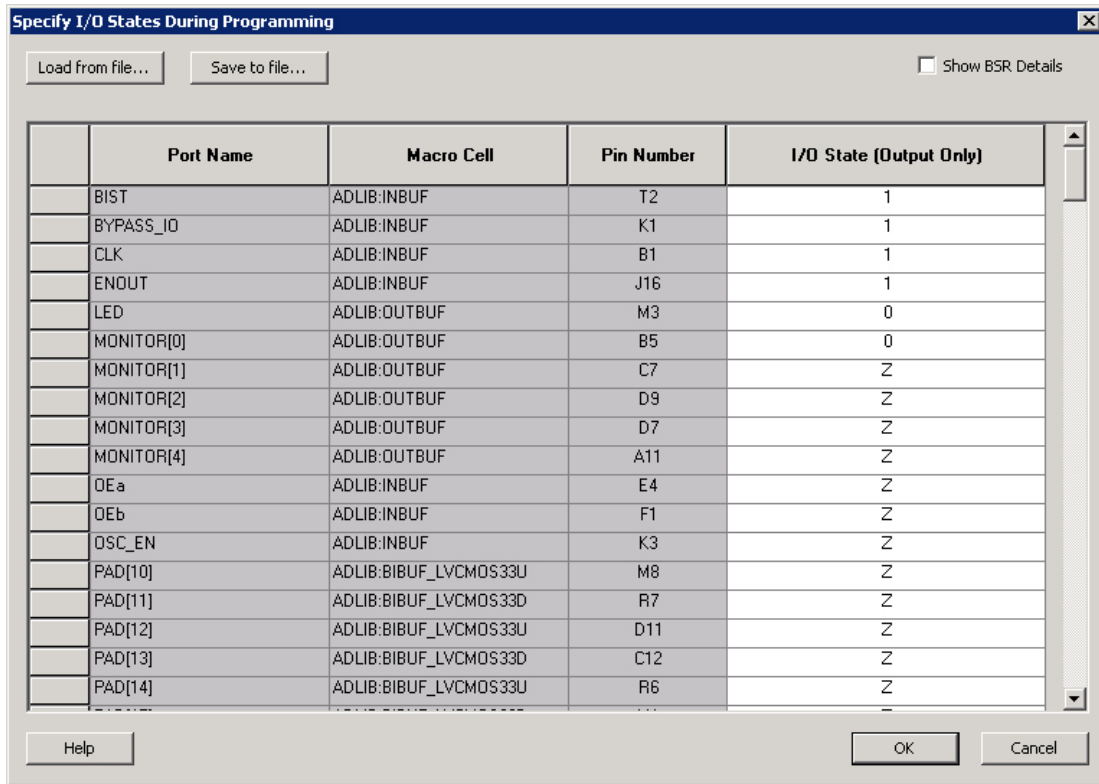

Figure 1-3 • I/O States During Programming Window

- Click OK to return to the FlashPoint – Programming File Generator window.
I/O States during programming are saved to the ADB and resulting programming files after completing programming file generation.

2 – ProASIC3E DC and Switching Characteristics

General Specifications

DC and switching characteristics for –F speed grade targets are based only on simulation.

The characteristics provided for the –F speed grade are subject to change after establishing FPGA specifications. Some restrictions might be added and will be reflected in future revisions of this document. The –F speed grade is only supported in the commercial temperature range.

Operating Conditions

Stresses beyond those listed in [Table 2-1](#) may cause permanent damage to the device.

Exposure to absolute maximum rating conditions for extended periods may affect device reliability. Absolute Maximum Ratings are stress ratings only; functional operation of the device at these or any other conditions beyond those listed under the Recommended Operating Conditions specified in [Table 2-2 on page 2-2](#) is not implied.

Table 2-1 • Absolute Maximum Ratings

Symbol	Parameter	Limits	Units
VCC	DC core supply voltage	–0.3 to 1.65	V
VJTAG	JTAG DC voltage	–0.3 to 3.75	V
VPUMP	Programming voltage	–0.3 to 3.75	V
VCCPLL	Analog power supply (PLL)	–0.3 to 1.65	V
VCCI ²	DC I/O output buffer supply voltage	–0.3 to 3.75	V
VMV ²	DC I/O input buffer supply voltage	–0.3 to 3.75	V
VI	I/O input voltage	–0.3 V to 3.6 V (when I/O hot insertion mode is enabled) –0.3 V to (VCCI + 1 V) or 3.6 V, whichever voltage is lower (when I/O hot-insertion mode is disabled)	V
T _{STG} ³	Storage temperature	–65 to +150	°C
T _J ³	Junction temperature	+125	°C

Notes:

1. The device should be operated within the limits specified by the datasheet. During transitions, the input signal may undershoot or overshoot according to the limits shown in [Table 2-3 on page 2-2](#).
2. VMV pins must be connected to the corresponding VCCI pins. See the "VMVx I/O Supply Voltage (quiet)" section on [page 3-1](#) for further information.
3. For flash programming and retention maximum limits, refer to [Table 2-3 on page 2-2](#), and for recommended operating limits, refer to [Table 2-2 on page 2-2](#).

Table 2-2 • Recommended Operating Conditions ¹

Symbol	Parameter	Commercial	Industrial	Units	
T _A	Ambient temperature	0 to +70	-40 to +85	°C	
T _J	Junction temperature	0 to +85	-40 to +100	°C	
VCC	1.5 V DC core supply voltage	1.425 to 1.575	1.425 to 1.575	V	
VJTAG	JTAG DC voltage	1.4 to 3.6	1.4 to 3.6	V	
VPUMP	Programming voltage	Programming Mode ²	3.15 to 3.45	3.15 to 3.45	V
		Operation ³	0 to 3.6	0 to 3.6	V
VCCPLL	Analog power supply (PLL)	1.425 to 1.575	1.425 to 1.575	V	
VCCI and VMV ⁴	1.5 V DC supply voltage	1.425 to 1.575	1.425 to 1.575	V	
	1.8 V DC supply voltage	1.7 to 1.9	1.7 to 1.9	V	
	2.5 V DC supply voltage	2.3 to 2.7	2.3 to 2.7	V	
	3.3 V DC supply voltage	3.0 to 3.6	3.0 to 3.6	V	
	3.0 V DC supply voltage ⁵	2.7 to 3.6	2.7 to 3.6	V	
	LVDS/B-LVDS/M-LVDS differential I/O	2.375 to 2.625	2.375 to 2.625	V	
	LVPECL differential I/O	3.0 to 3.6	3.0 to 3.6	V	

Notes:

1. All parameters representing voltages are measured with respect to GND unless otherwise specified.
2. The programming temperature range supported is $T_{ambient} = 0^{\circ}\text{C}$ to 85°C .
3. VPUMP can be left floating during normal operation (not programming mode).
4. The ranges given here are for power supplies only. The recommended input voltage ranges specific to each I/O standard are given in [Table 2-13 on page 2-17](#). VMV and VCCI should be at the same voltage within a given I/O bank. VMV pins must be connected to the corresponding VCCI pins. See the "[VMVx I/O Supply Voltage \(quiet\)](#)" section on [page 3-1](#) for further information.
5. To ensure targeted reliability standards are met across ambient and junction operating temperatures, Microsemi recommends that the user follow best design practices using Microsemi's timing and power simulation tools.
6. 3.3 V wide range is compliant to the JESD8-B specification and supports 3.0 V VCCI operation.

Table 2-3 • Flash Programming Limits – Retention, Storage and Operating Temperature ¹

Product Grade	Programming Cycles	Program Retention (biased/unbiased)	Maximum Storage Temperature T _{STG} (°C) ²	Maximum Operating Junction Temperature T _J (°C) ²
Commercial	500	20 years	110	100
Industrial	500	20 years	110	100

Notes:

1. This is a stress rating only; functional operation at any condition other than those indicated is not implied.
2. These limits apply for program/data retention only. Refer to [Table 2-1 on page 2-1](#) and [Table 2-2](#) for device operating conditions and absolute limits.

Table 2-4 • Overshoot and Undershoot Limits¹

VCCI and VMV	Average VCCI–GND Overshoot or Undershoot Duration as a Percentage of Clock Cycle ²	Maximum Overshoot/Undershoot ²
2.7 V or less	10%	1.4 V
	5%	1.49 V
3 V	10%	1.1 V
	5%	1.19 V
3.3 V	10%	0.79 V
	5%	0.88 V
3.6 V	10%	0.45 V
	5%	0.54 V

Notes:

1. Based on reliability requirements at 85°C.
2. The duration is allowed at one out of six clock cycles. If the overshoot/undershoot occurs at one out of two cycles, the maximum overshoot/undershoot has to be reduced by 0.15 V.
3. This table does not provide PCI overshoot/undershoot limits.

I/O Power-Up and Supply Voltage Thresholds for Power-On Reset (Commercial and Industrial)

Sophisticated power-up management circuitry is designed into every ProASIC[®]3E device. These circuits ensure easy transition from the powered-off state to the powered-up state of the device. The many different supplies can power up in any sequence with minimized current spikes or surges. In addition, the I/O will be in a known state through the power-up sequence. The basic principle is shown in [Figure 2-1 on page 2-4](#).

There are five regions to consider during power-up.

ProASIC3E I/Os are activated only if ALL of the following three conditions are met:

1. VCC and VCCI are above the minimum specified trip points ([Figure 2-1 on page 2-4](#)).
2. $VCCI > VCC - 0.75\text{ V}$ (typical)
3. Chip is in the operating mode.

VCCI Trip Point:

Ramping up: $0.6\text{ V} < \text{trip_point_up} < 1.2\text{ V}$

Ramping down: $0.5\text{ V} < \text{trip_point_down} < 1.1\text{ V}$

VCC Trip Point:

Ramping up: $0.6\text{ V} < \text{trip_point_up} < 1.1\text{ V}$

Ramping down: $0.5\text{ V} < \text{trip_point_down} < 1\text{ V}$

VCC and VCCI ramp-up trip points are about 100 mV higher than ramp-down trip points. This specifically built-in hysteresis prevents undesirable power-up oscillations and current surges. Note the following:

- During programming, I/Os become tristated and weakly pulled up to VCCI.
- JTAG supply, PLL power supplies, and charge pump VPUMP supply have no influence on I/O behavior.

PLL Behavior at Brownout Condition

Microsemi recommends using monotonic power supplies or voltage regulators to ensure proper power-up behavior. Power ramp-up should be monotonic at least until VCC and VCCPLXL exceed brownout activation levels. The VCC activation level is specified as 1.1 V worst-case (see Figure 2-1 on page 2-4 for more details).

When PLL power supply voltage and/or VCC levels drop below the VCC brownout levels ($0.75\text{ V} \pm 0.25\text{ V}$), the PLL output lock signal goes low and/or the output clock is lost. Refer to the "Power-Up/-Down Behavior of Low Power Flash Devices" chapter of the *ProASIC3E FPGA Fabric User's Guide* for information on clock and lock recovery.

Internal Power-Up Activation Sequence

1. Core
2. Input buffers
3. Output buffers, after 200 ns delay from input buffer activation

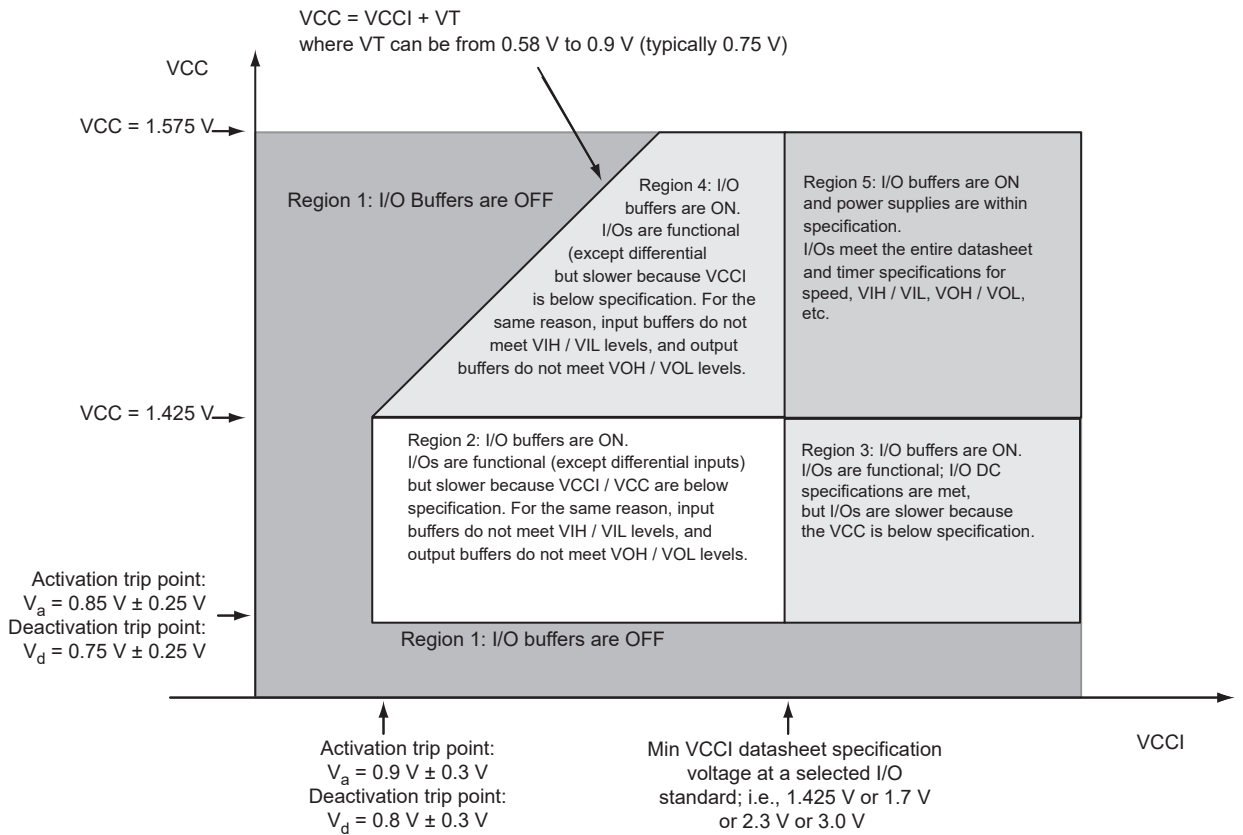

Figure 2-1 • I/O State as a Function of VCCI and VCC Voltage Levels

Thermal Characteristics

Introduction

The temperature variable in Designer software refers to the junction temperature, not the ambient temperature. This is an important distinction because dynamic and static power consumption cause the chip junction to be higher than the ambient temperature.

EQ 1 can be used to calculate junction temperature.

$$T_J = \text{Junction Temperature} = \Delta T + T_A$$

EQ 1

where:

T_A = Ambient Temperature

ΔT = Temperature gradient between junction (silicon) and ambient $\Delta T = \theta_{ja} * P$

θ_{ja} = Junction-to-ambient of the package. θ_{ja} numbers are located in [Table 2-5](#).

P = Power dissipation

Package Thermal Characteristics

The device junction-to-case thermal resistivity is θ_{jc} and the junction-to-ambient air thermal resistivity is θ_{ja} . The thermal characteristics for θ_{ja} are shown for two air flow rates. The absolute maximum junction temperature is 110°C. EQ 2 shows a sample calculation of the absolute maximum power dissipation allowed for an 896-pin FBGA package at commercial temperature and in still air.

$$\text{Maximum Power Allowed} = \frac{\text{Max. junction temp. (}^\circ\text{C)} - \text{Max. ambient temp. (}^\circ\text{C)}}{\theta_{ja} (\text{}^\circ\text{C/W)}} = \frac{110^\circ\text{C} - 70^\circ\text{C}}{13.6^\circ\text{C/W}} = 5.88 \text{ W}$$

EQ 2

Table 2-5 • Package Thermal Resistivities

Package Type	Pin Count	θ_{jc}	θ_{ja}			Units
			Still Air	200 ft./min.	500 ft./min.	
Plastic Quad Flat Package (PQFP)	208	8.0	26.1	22.5	20.8	C/W
Plastic Quad Flat Package (PQFP) with embedded heat spreader in A3PE3000	208	3.8	16.2	13.3	11.9	C/W
Fine Pitch Ball Grid Array (FBGA)	256	3.8	26.9	22.8	21.5	C/W
	484	3.2	20.5	17.0	15.9	C/W
	676	3.2	16.4	13.0	12.0	C/W
	896	2.4	13.6	10.4	9.4	C/W

Temperature and Voltage Derating Factors

Table 2-6 • Temperature and Voltage Derating Factors for Timing Delays
(normalized to $T_J = 70^\circ\text{C}$, $V_{CC} = 1.425\text{ V}$)

Array Voltage VCC (V)	Junction Temperature ($^\circ\text{C}$)					
	-40°C	0°C	25°C	70°C	85°C	100°C
1.425	0.87	0.92	0.95	1.00	1.02	1.04
1.500	0.83	0.88	0.90	0.95	0.97	0.98
1.575	0.80	0.85	0.87	0.92	0.93	0.95

Calculating Power Dissipation

Quiescent Supply Current

Table 2-7 • Quiescent Supply Current Characteristics

	A3PE600	A3PE1500	A3PE3000
Typical (25°C)	5 mA	12 mA	25 mA
Maximum (Commercial)	30 mA	70 mA	150 mA
Maximum (Industrial)	45 mA	105 mA	225 mA

Notes:

1. I_{DD} Includes V_{CC} , V_{PUMP} , V_{CCI} , and V_{MV} currents. Values do not include I/O static contribution, which is shown in Table 2-8 and Table 2-9 on page 2-7.
2. $-F$ speed grade devices may experience higher standby I_{DD} of up to five times the standard I_{DD} and higher I/O leakage.

Power per I/O Pin

Table 2-8 • Summary of I/O Input Buffer Power (per pin) – Default I/O Software Settings

	VMV (V)	Static Power PDC2 (mW) ¹	Dynamic Power PAC9 ($\mu\text{W}/\text{MHz}$) ²
Single-Ended			
3.3 V LVTTTL/LVCMOS	3.3	–	17.39
3.3 V LVTTTL/LVCMOS – Schmitt trigger	3.3	–	25.51
3.3 V LVTTTL/LVCMOS Wide Range ³	3.3	–	16.34
3.3 V LVTTTL/LVCMOS Wide Range – Schmitt trigger ³	3.3	–	24.49
2.5 V LVCMOS	2.5	–	5.76
2.5 V LVCMOS – Schmitt trigger	2.5	–	7.16
1.8 V LVCMOS	1.8	–	2.72
1.8 V LVCMOS – Schmitt trigger	1.8	–	2.80
1.5 V LVCMOS (JESD8-11)	1.5	–	2.08
1.5 V LVCMOS (JESD8-11) – Schmitt trigger	1.5	–	2.00
3.3 V PCI	3.3	–	18.82

Notes:

1. PDC2 is the static power (where applicable) measured on VMV.
2. PAC9 is the total dynamic power measured on VCC and VMV.
3. All LVCMOS 3.3 V software macros support LVCMOS 3.3 V wide range as specified in the JESD8b specification.

Table 2-8 • Summary of I/O Input Buffer Power (per pin) – Default I/O Software Settings (continued)

	VMV (V)	Static Power PDC2 (mW) ¹	Dynamic Power PAC9 (μW/MHz) ²
3.3 V PCI – Schmitt trigger	3.3	–	20.12
3.3 V PCI-X	3.3	–	18.82
3.3 V PCI-X – Schmitt trigger	3.3	–	20.12
Voltage-Referenced			
3.3 V GTL	3.3	2.90	8.23
2.5 V GTL	2.5	2.13	4.78
3.3 V GTL+	3.3	2.81	4.14
2.5 V GTL+	2.5	2.57	3.71
HSTL (I)	1.5	0.17	2.03
HSTL (II)	1.5	0.17	2.03
SSTL2 (I)	2.5	1.38	4.48
SSTL2 (II)	2.5	1.38	4.48
SSTL3 (I)	3.3	3.21	9.26
SSTL3 (II)	3.3	3.21	9.26
Differential			
LVDS/B-LVDS/M-LVDS	2.5	2.26	1.50
LVPECL	3.3	5.71	2.17

Notes:

1. PDC2 is the static power (where applicable) measured on VMV.
2. PAC9 is the total dynamic power measured on VCC and VMV.
3. All LVCMOS 3.3 V software macros support LVCMOS 3.3 V wide range as specified in the JESD8b specification.

Table 2-9 • Summary of I/O Output Buffer Power (per pin) – Default I/O Software Settings ¹

	C _{LOAD} (pF)	VCCI (V)	Static Power PDC3 (mW) ²	Dynamic Power PAC10 (μW/MHz) ³
Single-Ended				
3.3 V LVTTTL/LVCMOS	35	3.3	–	474.70
3.3 V LVTTTL/LVCMOS Wide Range ⁴	35	3.3	–	474.70
2.5 V LVCMOS	35	2.5	–	270.73
1.8 V LVCMOS	35	1.8	–	151.78
1.5 V LVCMOS (JESD8-11)	35	1.5	–	104.55
3.3 V PCI	10	3.3	–	204.61
3.3 V PCI-X	10	3.3	–	204.61
Voltage-Referenced				
3.3 V GTL	10	3.3	–	24.08
2.5 V GTL	10	2.5	–	13.52
3.3 V GTL+	10	3.3	–	24.10
2.5 V GTL+	10	2.5	–	13.54

Table 2-9 • Summary of I/O Output Buffer Power (per pin) – Default I/O Software Settings (continued) (continued)¹

	C_{LOAD} (pF)	VCCI (V)	Static Power PDC3 (mW) ²	Dynamic Power PAC10 (μ W/MHz) ³
HSTL (I)	20	1.5	7.08	26.22
HSTL (II)	20	1.5	13.88	27.22
SSTL2 (I)	30	2.5	16.69	105.56
SSTL2 (II)	30	2.5	25.91	116.60
Notes:				
1. Dynamic power consumption is given for standard load and software default drive strength and output slew.				
2. PDC3 is the static power (where applicable) measured on VCCI.				
3. PAC10 is the total dynamic power measured on VCC and VCCI.				
4. All LVCMOS 3.3 V software macros support LVCMOS 3.3 V wide range as specified in the JESD8-B specification.				
SSTL3 (I)	30	3.3	26.02	114.87
SSTL3 (II)	30	3.3	42.21	131.76
Differential				
LVDS/B-LVDS/M-LVDS	–	2.5	7.70	89.62
LVPECL	–	3.3	19.42	168.02
Notes:				
1. Dynamic power consumption is given for standard load and software default drive strength and output slew.				
2. PDC3 is the static power (where applicable) measured on VCCI.				
3. PAC10 is the total dynamic power measured on VCC and VCCI.				
4. All LVCMOS 3.3 V software macros support LVCMOS 3.3 V wide range as specified in the JESD8-B specification.				

Power Consumption of Various Internal Resources

Table 2-10 • Different Components Contributing to the Dynamic Power Consumption in ProASIC3E Devices

Parameter	Definition	Device-Specific Dynamic Contributions (μ W/MHz)		
		A3PE600	A3PE1500	A3PE3000
PAC1	Clock contribution of a Global Rib	12.77	16.21	19.7
PAC2	Clock contribution of a Global Spine	1.85	3.06	4.16
PAC3	Clock contribution of a VersaTile row	0.88		
PAC4	Clock contribution of a VersaTile used as a sequential module	0.12		
PAC5	First contribution of a VersaTile used as a sequential module	0.07		
PAC6	Second contribution of a VersaTile used as a sequential module	0.29		
PAC7	Contribution of a VersaTile used as a combinatorial module	0.29		
PAC8	Average contribution of a routing net	0.70		
PAC9	Contribution of an I/O input pin (standard-dependent)	See Table 2-8 on page 2-6.		
PAC10	Contribution of an I/O output pin (standard-dependent)	See Table 2-9 on page 2-7		
PAC11	Average contribution of a RAM block during a read operation	25.00		

Table 2-10 • Different Components Contributing to the Dynamic Power Consumption in ProASIC3E Devices

Parameter	Definition	Device-Specific Dynamic Contributions (μW/MHz)		
		A3PE600	A3PE1500	A3PE3000
PAC12	Average contribution of a RAM block during a write operation	30.00		
PAC13	Static PLL contribution	2.55 mW		
PAC14	Dynamic contribution for PLL	2.60		

Note: For a different output load, drive strength, or slew rate, Microsemi recommends using the Microsemi power calculator or SmartPower in Libero SoC.

Power Calculation Methodology

This section describes a simplified method to estimate power consumption of an application. For more accurate and detailed power estimations, use the SmartPower tool in the Libero SoC software.

The power calculation methodology described below uses the following variables:

- The number of PLLs as well as the number and the frequency of each output clock generated
- The number of combinatorial and sequential cells used in the design
- The internal clock frequencies
- The number and the standard of I/O pins used in the design
- The number of RAM blocks used in the design
- Toggle rates of I/O pins as well as VersaTiles—guidelines are provided in [Table 2-11 on page 2-12](#).
- Enable rates of output buffers—guidelines are provided for typical applications in [Table 2-12 on page 2-12](#).
- Read rate and write rate to the memory—guidelines are provided for typical applications in [Table 2-12 on page 2-12](#). The calculation should be repeated for each clock domain defined in the design.

Methodology

Total Power Consumption— P_{TOTAL}

$$P_{TOTAL} = P_{STAT} + P_{DYN}$$

P_{STAT} is the total static power consumption.

P_{DYN} is the total dynamic power consumption.

Total Static Power Consumption— P_{STAT}

$$P_{STAT} = PDC1 + N_{INPUTS} * PDC2 + N_{OUTPUTS} * PDC3$$

N_{INPUTS} is the number of I/O input buffers used in the design.

$N_{OUTPUTS}$ is the number of I/O output buffers used in the design.

Total Dynamic Power Consumption— P_{DYN}

$$P_{DYN} = P_{CLOCK} + P_{S-CELL} + P_{C-CELL} + P_{NET} + P_{INPUTS} + P_{OUTPUTS} + P_{MEMORY} + P_{PLL}$$

Global Clock Contribution— P_{CLOCK}

$$P_{CLOCK} = (PAC1 + N_{SPINE} * PAC2 + N_{ROW} * PAC3 + N_{S-CELL} * PAC4) * F_{CLK}$$

N_{SPINE} is the number of global spines used in the user design—guidelines are provided in the "Spine Architecture" section of the Global Resources chapter in the [ProASIC3E FPGA Fabric User's Guide](#).

N_{ROW} is the number of VersaTile rows used in the design—guidelines are provided in the "Spine Architecture" section of the Global Resources chapter in the [ProASIC3E FPGA Fabric User's Guide](#).

F_{CLK} is the global clock signal frequency.

N_{S-CELL} is the number of VersaTiles used as sequential modules in the design.

PAC1, PAC2, PAC3, and PAC4 are device-dependent.

Sequential Cells Contribution— P_{S-CELL}

$$P_{S-CELL} = N_{S-CELL} * (PAC5 + \alpha_1 / 2 * PAC6) * F_{CLK}$$

N_{S-CELL} is the number of VersaTiles used as sequential modules in the design. When a multi-tile sequential cell is used, it should be accounted for as 1.

α_1 is the toggle rate of VersaTile outputs—guidelines are provided in [Table 2-11 on page 2-12](#).

F_{CLK} is the global clock signal frequency.

Combinatorial Cells Contribution— P_{C-CELL}

$$P_{C-CELL} = N_{C-CELL} * \alpha_1 / 2 * PAC7 * F_{CLK}$$

N_{C-CELL} is the number of VersaTiles used as combinatorial modules in the design.

α_1 is the toggle rate of VersaTile outputs—guidelines are provided in [Table 2-11 on page 2-12](#).

F_{CLK} is the global clock signal frequency.

Routing Net Contribution— P_{NET}

$$P_{NET} = (N_{S-CELL} + N_{C-CELL}) * \alpha_1 / 2 * PAC8 * F_{CLK}$$

N_{S-CELL} is the number of VersaTiles used as sequential modules in the design.

N_{C-CELL} is the number of VersaTiles used as combinatorial modules in the design.

α_1 is the toggle rate of VersaTile outputs—guidelines are provided in [Table 2-11 on page 2-12](#).

F_{CLK} is the global clock signal frequency.

I/O Input Buffer Contribution— P_{INPUTS}

$$P_{INPUTS} = N_{INPUTS} * \alpha_2 / 2 * PAC9 * F_{CLK}$$

N_{INPUTS} is the number of I/O input buffers used in the design.

α_2 is the I/O buffer toggle rate—guidelines are provided in [Table 2-11 on page 2-12](#).

F_{CLK} is the global clock signal frequency.

I/O Output Buffer Contribution— $P_{OUTPUTS}$

$$P_{OUTPUTS} = N_{OUTPUTS} * \alpha_2 / 2 * \beta_1 * PAC10 * F_{CLK}$$

$N_{OUTPUTS}$ is the number of I/O output buffers used in the design.

α_2 is the I/O buffer toggle rate—guidelines are provided in [Table 2-11 on page 2-12](#).

β_1 is the I/O buffer enable rate—guidelines are provided in [Table 2-12 on page 2-12](#).

F_{CLK} is the global clock signal frequency.

RAM Contribution— P_{MEMORY}

$$P_{MEMORY} = PAC11 * N_{BLOCKS} * F_{READ-CLOCK} * \beta_2 + PAC12 * N_{BLOCK} * F_{WRITE-CLOCK} * \beta_3$$

N_{BLOCKS} is the number of RAM blocks used in the design.

$F_{READ-CLOCK}$ is the memory read clock frequency.

β_2 is the RAM enable rate for read operations—guidelines are provided in [Table 2-12 on page 2-12](#).

$F_{WRITE-CLOCK}$ is the memory write clock frequency.

β_3 is the RAM enable rate for write operations—guidelines are provided in [Table 2-12 on page 2-12](#).

PLL Contribution— P_{PLL}

$$P_{PLL} = PAC13 + PAC14 * F_{CLKOUT}$$

F_{CLKOUT} is the output clock frequency.¹

1. The PLL dynamic contribution depends on the input clock frequency, the number of output clock signals generated by the PLL, and the frequency of each output clock. If a PLL is used to generate more than one output clock, include each output clock in the formula by adding its corresponding contribution ($PAC14 * F_{CLKOUT}$ product) to the total PLL contribution.

Guidelines

Toggle Rate Definition

A toggle rate defines the frequency of a net or logic element relative to a clock. It is a percentage. If the toggle rate of a net is 100%, this means that this net switches at half the clock frequency. Below are some examples:

- The average toggle rate of a shift register is 100% as all flip-flop outputs toggle at half of the clock frequency.
- The average toggle rate of an 8-bit counter is 25%:
 - Bit 0 (LSB) = 100%
 - Bit 1 = 50%
 - Bit 2 = 25%
 - ...
 - Bit 7 (MSB) = 0.78125%
 - Average toggle rate = $(100\% + 50\% + 25\% + 12.5\% + \dots + 0.78125\%) / 8$

Enable Rate Definition

Output enable rate is the average percentage of time during which tristate outputs are enabled. When nontristate output buffers are used, the enable rate should be 100%.

Table 2-11 • Toggle Rate Guidelines Recommended for Power Calculation

Component	Definition	Guideline
α_1	Toggle rate of VersaTile outputs	10%
α_2	I/O buffer toggle rate	10%

Table 2-12 • Enable Rate Guidelines Recommended for Power Calculation

Component	Definition	Guideline
β_1	I/O output buffer enable rate	100%
β_2	RAM enable rate for read operations	12.5%
β_3	RAM enable rate for write operations	12.5%

User I/O Characteristics

Timing Model

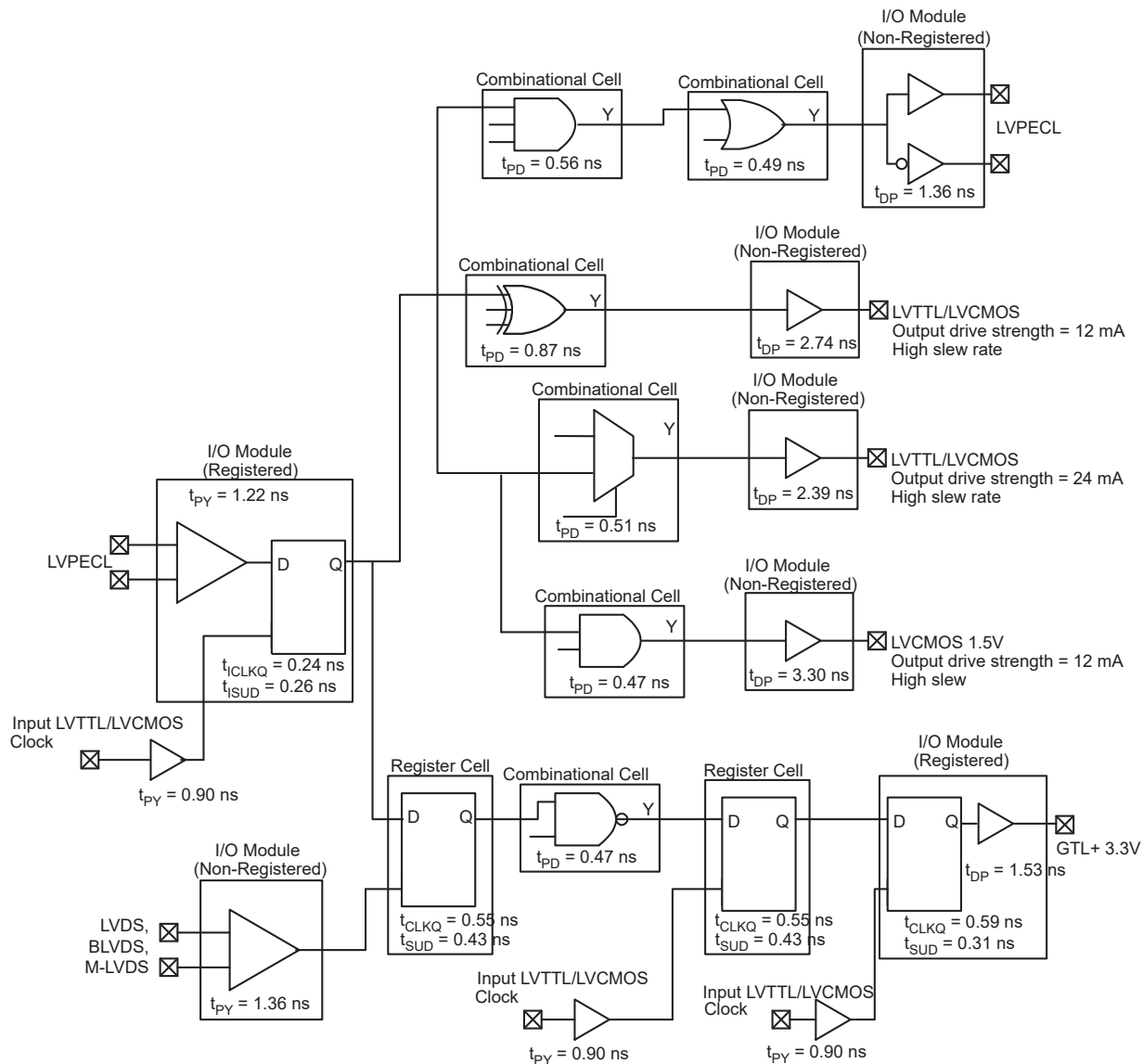
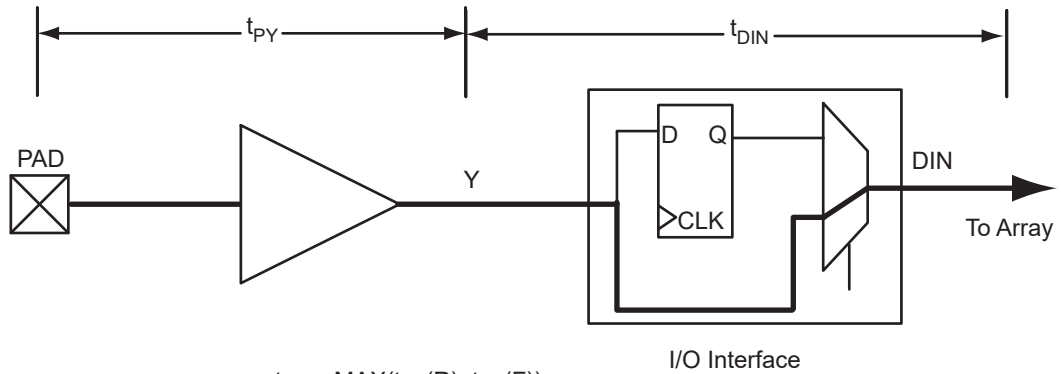

Figure 2-2 • Timing Model
 Operating Conditions: -2 Speed, Commercial Temperature Range ($T_J = 70^\circ\text{C}$), Worst-Case
 $V_{CC} = 1.425\text{ V}$



$$t_{PY} = \text{MAX}(t_{PY}(R), t_{PY}(F))$$

$$t_{DIN} = \text{MAX}(t_{DIN}(R), t_{DIN}(F))$$

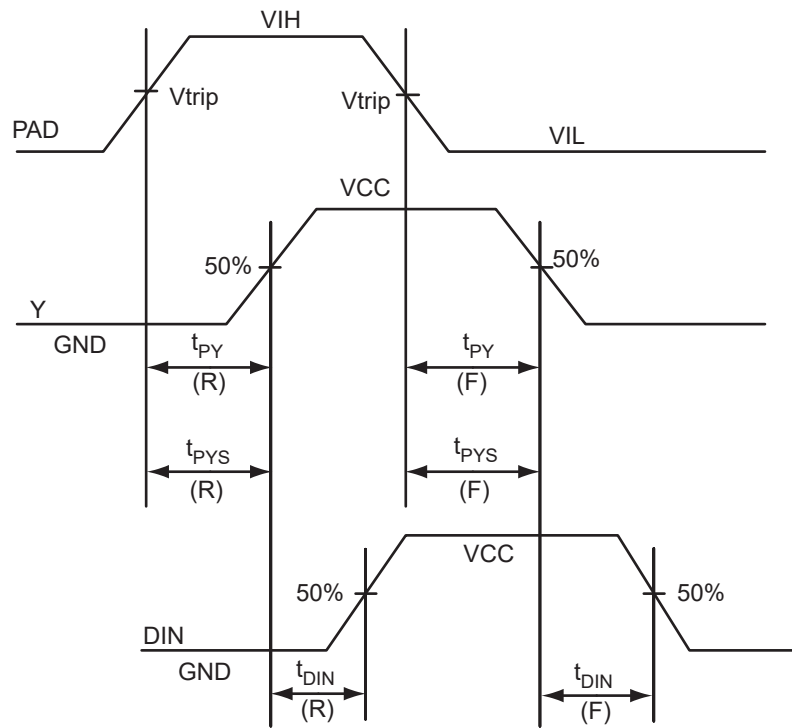

Figure 2-3 • Input Buffer Timing Model and Delays (example)

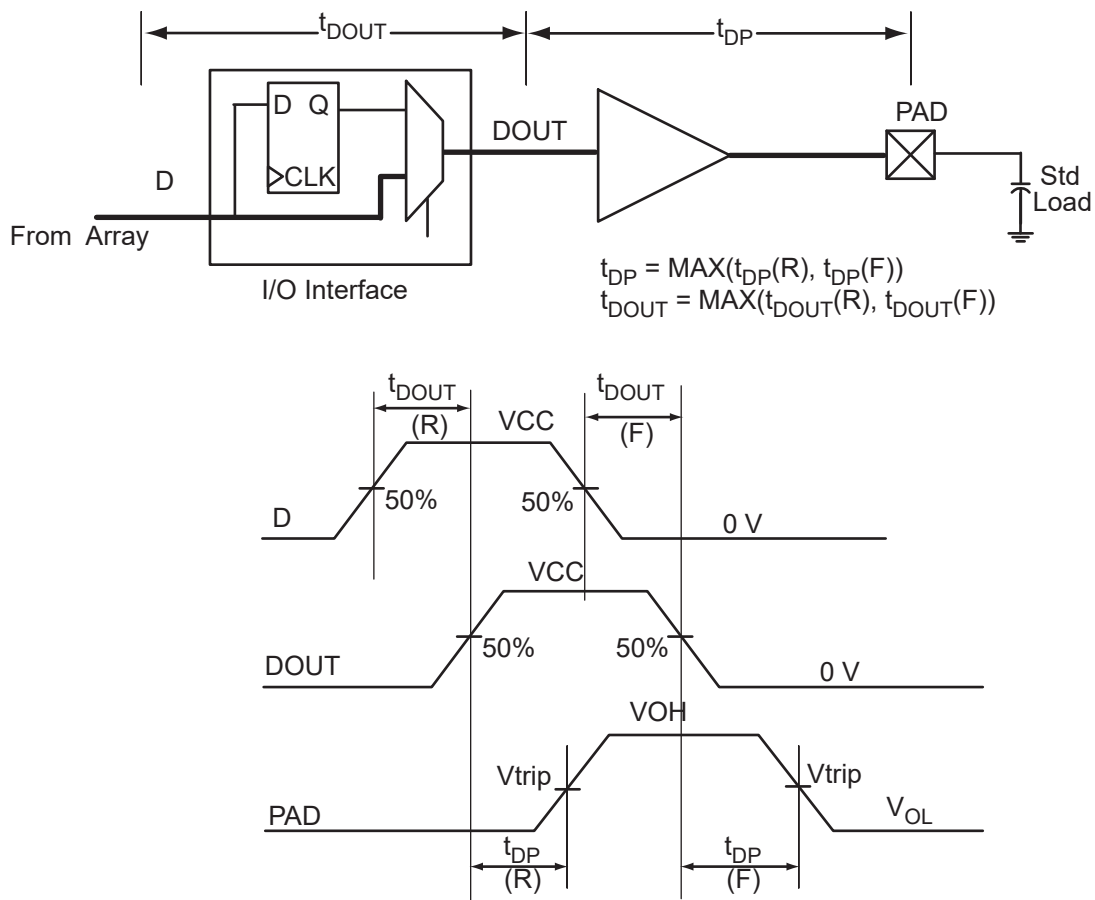

Figure 2-4 • Output Buffer Model and Delays (example)

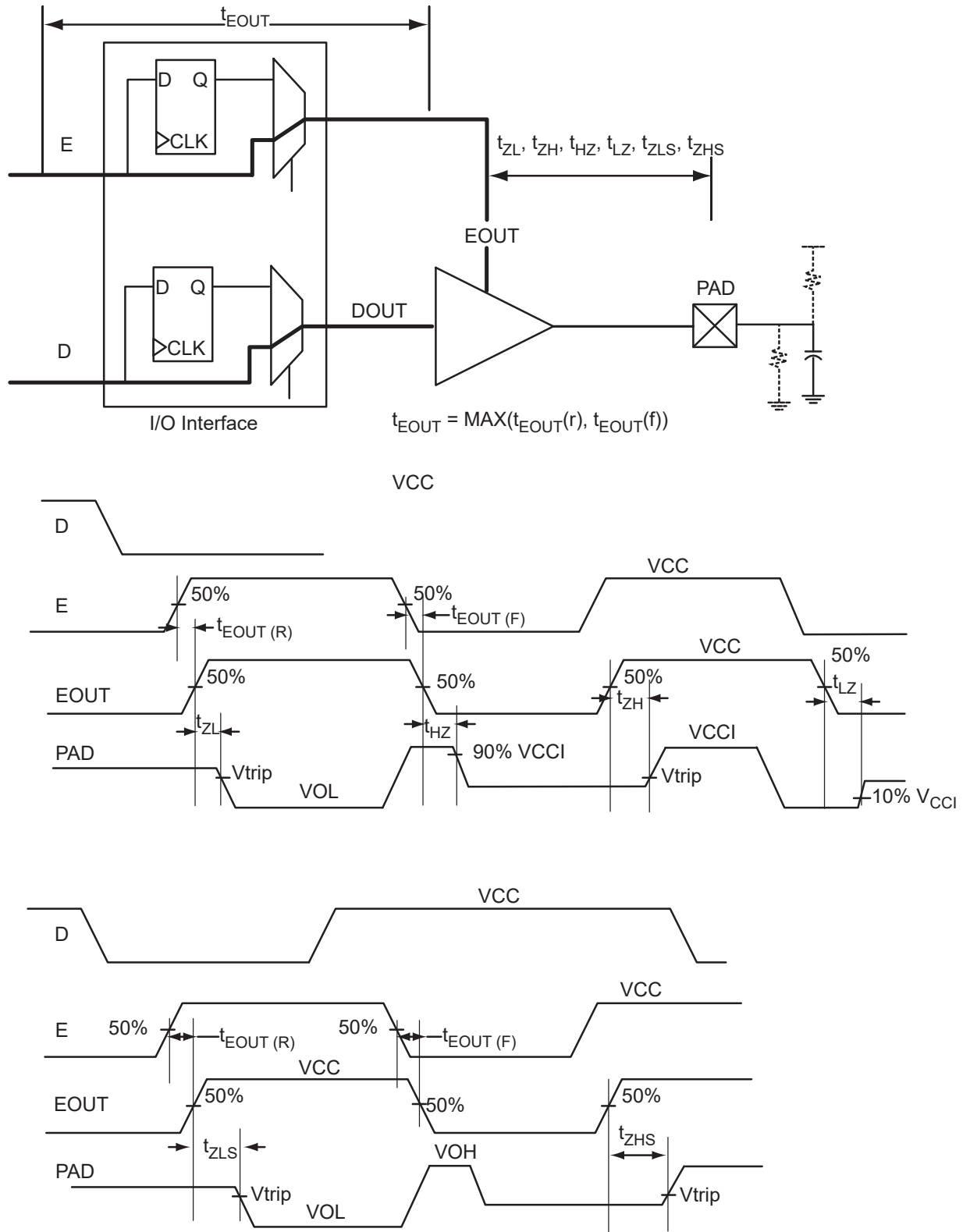

Figure 2-5 • Tristate Output Buffer Timing Model and Delays (example)

Overview of I/O Performance

Summary of I/O DC Input and Output Levels – Default I/O Software Settings

Table 2-13 • Summary of Maximum and Minimum DC Input and Output Levels
 Applicable to Commercial and Industrial Conditions

I/O Standard	Drive Strength	Equivalent Software Default Drive Strength Option ¹	Slew Rate	VIL		VIH		VOL	VOH	IOL ³	IOH ³
				Min. V	Max. V	Min. V	Max. V	Max. V	Min. V	mA	mA
3.3 V LVTTTL / 3.3 V LVC MOS	12 mA	12 mA	High	-0.3	0.8	2	3.6	0.4	2.4	12	12
3.3 V LVC MOS Wide Range	100 μ A	12 mA	High	-0.3	0.8	2	3.6	0.2	VCCI - 0.2	0.1	0.1
2.5 V LVC MOS	12 mA	12 mA	High	-0.3	0.7	1.7	3.6	0.7	1.7	12	12
1.8 V LVC MOS	12 mA	12 mA	High	-0.3	0.35 * VCCI	0.65 * VCCI	3.6	0.45	VCCI - 0.45	12	12
1.5 V LVC MOS	12 mA	12 mA	High	-0.3	0.30 * VCCI	0.7 * VCCI	3.6	0.25 * VCCI	0.75 * VCCI	12	12
3.3 V PCI	Per PCI Specification										
3.3 V PCI-X	Per PCI-X Specification										
3.3 V GTL	20 mA ²	20 mA ²	High	-0.3	VREF - 0.05	VREF + 0.05	3.6	0.4	-	20	20
2.5 V GTL	20 mA ²	20 mA ²	High	-0.3	VREF - 0.05	VREF + 0.05	3.6	0.4	-	20	20
3.3 V GTL+	35 mA	35 mA	High	-0.3	VREF - 0.1	VREF + 0.1	3.6	0.6	-	35	35
2.5 V GTL+	33 mA	33 mA	High	-0.3	VREF - 0.1	VREF + 0.1	3.6	0.6	-	33	33
HSTL (I)	8 mA	8 mA	High	-0.3	VREF - 0.1	VREF + 0.1	3.6	0.4	VCCI - 0.4	8	8
HSTL (II)	15 mA ²	15 mA ²	High	-0.3	VREF - 0.1	VREF + 0.1	3.6	0.4	VCCI - 0.4	15	15
SSTL2 (I)	15 mA	15 mA	High	-0.3	VREF - 0.2	VREF + 0.2	3.6	0.54	VCCI - 0.62	15	15
SSTL2 (II)	18 mA	18 mA	High	-0.3	VREF - 0.2	VREF + 0.2	3.6	0.35	VCCI - 0.43	18	18
SSTL3 (I)	14 mA	14 mA	High	-0.3	VREF - 0.2	VREF + 0.2	3.6	0.7	VCCI - 1.1	14	14
SSTL3 (II)	21 mA	21 mA	High	-0.3	VREF - 0.2	VREF + 0.2	3.6	0.5	VCCI - 0.9	21	21

Notes:

1. The minimum drive strength for any LVC MOS 3.3 V software configuration when run in wide range is $\pm 100 \mu$ A. Drive strength displayed in the software is supported for normal range only. For a detailed I/V curve, refer to the IBIS models.
2. Output drive strength is below JEDEC specification.
3. Currents are measured at 85°C junction temperature.
4. Output Slew Rates can be extracted from IBIS Models, located at http://www.microsemi.com/index.php?option=com_content&id=1671&lang=en&view=article.

**Table 2-14 • Summary of Maximum and Minimum DC Input Levels
Applicable to Commercial and Industrial Conditions**

DC I/O Standards	Commercial ¹		Industrial ²	
	IIL ³	IIH ⁴	IIL ³	IIH ⁴
	μA	μA	μA	μA
3.3 V LVTTTL / 3.3 V LVCMOS	10	10	15	15
3.3 V LVCMOS Wide Range	10	10	15	15
2.5 V LVCMOS	10	10	15	15
1.8 V LVCMOS	10	10	15	15
1.5 V LVCMOS	10	10	15	15
3.3 V PCI	10	10	15	15
3.3 V PCI-X	10	10	15	15
3.3 V GTL	10	10	15	15
2.5 V GTL	10	10	15	15
3.3 V GTL+	10	10	15	15
2.5 V GTL+	10	10	15	15
HSTL (I)	10	10	15	15
HSTL (II)	10	10	15	15
SSTL2 (I)	10	10	15	15
SSTL2 (II)	10	10	15	15
SSTL3 (I)	10	10	15	15
SSTL3 (II)	10	10	15	15

Notes:

1. Commercial range ($0^{\circ}\text{C} < T_A < 70^{\circ}\text{C}$)
2. Industrial range ($-40^{\circ}\text{C} < T_A < 85^{\circ}\text{C}$)
3. IIL is the input leakage current per I/O pin over recommended operation conditions where $-0.3\text{ V} < V_{IN} < V_{IL}$.
4. IIH is the input leakage current per I/O pin over recommended operating conditions $V_{IH} < V_{IN} < V_{CCI}$. Input current is larger when operating outside recommended ranges.

Summary of I/O Timing Characteristics – Default I/O Software Settings

Table 2-15 • Summary of AC Measuring Points

Standard	Input Reference Voltage (VREF_TYP)	Board Termination Voltage (VTT_REF)	Measuring Trip Point (Vtrip)
3.3 V LVTTTL / 3.3 V LVCMOS	–	–	1.4 V
3.3 V LVCMOS Wide Range	–	–	1.4 V
2.5 V LVCMOS	–	–	1.2 V
1.8 V LVCMOS	–	–	0.90 V
1.5 V LVCMOS	–	–	0.75 V
3.3 V PCI	–	–	0.285 * VCCI (RR) 0.615 * VCCI (FF))
3.3 V PCI-X	–	–	0.285 * VCCI (RR) 0.615 * VCCI (FF)
3.3 V GTL	0.8 V	1.2 V	VREF
2.5 V GTL	0.8 V	1.2 V	VREF
3.3 V GTL+	1.0 V	1.5 V	VREF
2.5 V GTL+	1.0 V	1.5 V	VREF
HSTL (I)	0.75 V	0.75 V	VREF
HSTL (II)	0.75 V	0.75 V	VREF
SSTL2 (I)	1.25 V	1.25 V	VREF
SSTL2 (II)	1.25 V	1.25 V	VREF
SSTL3 (I)	1.5 V	1.485 V	VREF
SSTL3 (II)	1.5 V	1.485 V	VREF
LVDS	–	–	Cross point
LVPECL	–	–	Cross point

Table 2-16 • I/O AC Parameter Definitions

Parameter	Definition
t _{DP}	Data to Pad delay through the Output Buffer
t _{PY}	Pad to Data delay through the Input Buffer with Schmitt trigger disabled
t _{DOUT}	Data to Output Buffer delay through the I/O interface
t _{EOUT}	Enable to Output Buffer Tristate Control delay through the I/O interface
t _{DIN}	Input Buffer to Data delay through the I/O interface
t _{PYS}	Pad to Data delay through the Input Buffer with Schmitt trigger enabled
t _{HZ}	Enable to Pad delay through the Output Buffer—High to Z
t _{ZH}	Enable to Pad delay through the Output Buffer—Z to High
t _{LZ}	Enable to Pad delay through the Output Buffer—Low to Z
t _{ZL}	Enable to Pad delay through the Output Buffer—Z to Low
t _{ZHS}	Enable to Pad delay through the Output Buffer with delayed enable—Z to High
t _{ZLS}	Enable to Pad delay through the Output Buffer with delayed enable—Z to Low

Table 2-17 • Summary of I/O Timing Characteristics—Software Default Settings
–2 Speed Grade, Commercial-Case Conditions: T_J = 70°C, Worst-Case VCC = 1.425 V,
Worst-Case VCCI = 3.0 V

I/O Standard	Drive Strength (mA)	Equivalent Software Default Drive Strength Option) ¹	Slew Rate	Capacitive Load (pF)	External Resistor (Ω)	t _{DOUT} (ns)	t _{DP} (ns)	t _{DIN} (ns)	t _{py} (ns)	t _{pys} (ns)	t _{EOUT} (ns)	t _{ZL} (ns)	t _{ZH} (ns)	t _{LZ} (ns)	t _{HZ} (ns)	t _{ZLS} (ns)	t _{ZHS} (ns)
3.3 V LVTTTL / 3.3 V LVCMOS	12	12	High	35	–	0.49	2.74	0.03	0.90	1.17	0.32	2.79	2.14	2.45	2.70	4.46	3.81
3.3 V LVCMOS Wide Range ²	100 μA	12	High	35	–	0.49	4.24	0.03	1.36	1.78	0.32	4.24	3.25	3.78	4.17	6.77	5.79
2.5 V LVCMOS	12	12	High	35	–	0.49	2.80	0.03	1.13	1.24	0.32	2.85	2.61	2.51	2.61	4.52	4.28
1.8 V LVCMOS	12	12	High	35	–	0.49	2.83	0.03	1.08	1.42	0.32	2.89	2.31	2.79	3.16	4.56	3.98
1.5 V LVCMOS	12	12	High	35	–	0.49	3.30	0.03	1.27	1.60	0.32	3.36	2.70	2.96	3.27	5.03	4.37
3.3 V PCI	Per PCI spec	–	High	10	25 ³	0.49	2.09	0.03	0.78	1.17	0.32	2.13	1.49	2.45	2.70	3.80	3.16
3.3 V PCI-X	Per PCI-X spec	–	High	10	25 ³	0.49	2.09	0.03	0.78	1.17	0.32	2.13	1.49	2.45	2.70	3.80	3.16
3.3 V GTL	20 ⁴	–	High	10	25	0.45	1.55	0.03	2.19	–	0.32	1.52	1.55	–	–	3.19	3.22
2.5 V GTL	20 ⁴	–	High	10	25	0.45	1.59	0.03	1.83	–	0.32	1.61	1.59	–	–	3.28	3.26
3.3 V GTL+	35	–	High	10	25	0.45	1.53	0.03	1.19	–	0.32	1.56	1.53	–	–	3.23	3.20
2.5 V GTL+	33	–	High	10	25	0.45	1.65	0.03	1.13	–	0.32	1.68	1.57	–	–	3.35	3.24
HSTL (I)	8	–	High	20	50	0.49	2.37	0.03	1.59	–	0.32	2.42	2.35	–	–	4.09	4.02
HSTL (II)	15 ⁴	–	High	20	25	0.49	2.26	0.03	1.59	–	0.32	2.30	2.03	–	–	3.97	3.70
SSTL2 (I)	15	–	High	30	50	0.49	1.59	0.03	1.00	–	0.32	1.62	1.38	–	–	3.29	3.05
SSTL2 (II)	18	–	High	30	25	0.49	1.62	0.03	1.00	–	0.32	1.65	1.32	–	–	3.32	2.99
SSTL3 (I)	14	–	High	30	50	0.49	1.72	0.03	0.93	–	0.32	1.75	1.37	–	–	3.42	3.04
SSTL3 (II)	21	–	High	30	25	0.49	1.54	0.03	0.93	–	0.32	1.57	1.25	–	–	3.24	2.92
LVDS/B-LVDS/M-LVDS	24	–	High	–	–	0.49	1.40	0.03	1.36	–	–	–	–	–	–	–	–
LVPECL	24	–	High	–	–	0.49	1.36	0.03	1.22	–	–	–	–	–	–	–	–

Notes:

1. The minimum drive strength for any LVCMOS 3.3 V software configuration when run in wide range is ±100 μA. Drive strength displayed in the software is supported for normal range only. For a detailed I/V curve, refer to the IBIS models.
2. All LVCMOS 3.3 V software macros support LVCMOS 3.3V wide range as specified in the JESD8b specification.
3. Resistance is used to measure I/O propagation delays as defined in PCI specifications. See [Figure 2-11 on page 2-39](#) for connectivity. This resistor is not required during normal operation.
4. Output drive strength is below JEDEC specification.
5. For specific junction temperature and voltage supply levels, refer to [Table 2-6 on page 2-6](#).

Detailed I/O DC Characteristics

Table 2-18 • Input Capacitance

Symbol	Definition	Conditions	Min.	Max.	Units
C _{IN}	Input capacitance	V _{IN} = 0, f = 1.0 MHz		8	pF
C _{INCLK}	Input capacitance on the clock pin	V _{IN} = 0, f = 1.0 MHz		8	pF

Table 2-19 • I/O Output Buffer Maximum Resistances¹

Standard	Drive Strength	R _{PULL-DOWN} (Ω) ²	R _{PULL-UP} (Ω) ³
3.3 V LVTTTL / 3.3 V LVCMOS	4 mA	100	300
	8 mA	50	150
	12 mA	25	75
	16 mA	17	50
	24 mA	11	33
3.3 V LVCMOS Wide Range	100 μA	Same as regular 3.3 V LVCMOS	Same as regular 3.3 V LVCMOS
2.5 V LVCMOS	4 mA	100	200
	8 mA	50	100
	12 mA	25	50
	16 mA	20	40
	24 mA	11	22
1.8 V LVCMOS	2 mA	200	225
	4 mA	100	112
	6 mA	50	56
	8 mA	50	56
	12 mA	20	22
	16 mA	20	22
1.5 V LVCMOS	2 mA	200	224
	4 mA	100	112
	6 mA	67	75
	8 mA	33	37
	12 mA	33	37
3.3 V PCI/PCI-X	Per PCI/PCI-X specification	25	75
3.3 V GTL	20 mA ⁴	11	–
2.5 V GTL	20 mA ⁴	14	–

Notes:

1. These maximum values are provided for informational reasons only. Minimum output buffer resistance values depend on V_{CCI}, drive strength selection, temperature, and process. For board design considerations and detailed output buffer resistances, use the corresponding IBIS models located on the Microsemi SoC Products Group website at www.microsemi.com/index.php?option=com_content&id=1671&lang=en&view=article.
2. $R_{(PULL-DOWN-MAX)} = (VOL_{spec}) / IOL_{spec}$
3. $R_{(PULL-UP-MAX)} = (VCCI_{max} - VOH_{spec}) / IOH_{spec}$
4. Output drive strength is below JEDEC specification.

Table 2-19 • I/O Output Buffer Maximum Resistances¹ (continued)

Standard	Drive Strength	R _{PULL-DOWN} (Ω) ²	R _{PULL-UP} (Ω) ³
3.3 V GTL+	35 mA	12	–
2.5 V GTL+	33 mA	15	–
HSTL (I)	8 mA	50	50
HSTL (II)	15 mA ⁴	25	25
SSTL2 (I)	15 mA	27	31
SSTL2 (II)	18 mA	13	15
SSTL3 (I)	14 mA	44	69
SSTL3 (II)	21 mA	18	32

Notes:

1. These maximum values are provided for informational reasons only. Minimum output buffer resistance values depend on VCCI, drive strength selection, temperature, and process. For board design considerations and detailed output buffer resistances, use the corresponding IBIS models located on the Microsemi SoC Products Group website at www.microsemi.com/index.php?option=com_content&id=1671&lang=en&view=article.
2. $R_{(PULL-DOWN-MAX)} = (VOL_{spec}) / IOL_{spec}$
3. $R_{(PULL-UP-MAX)} = (VCCI_{max} - VOH_{spec}) / IOH_{spec}$
4. Output drive strength is below JEDEC specification.

**Table 2-20 • I/O Weak Pull-Up/Pull-Down Resistances
Minimum and Maximum Weak Pull-Up/Pull-Down Resistance Values**

VCCI	R _(WEAK PULL-UP) ¹ (Ω)		R _(WEAK PULL-DOWN) ² (Ω)	
	Min.	Max.	Min.	Max.
3.3 V	10 k	45 k	10 k	45 k
3.3 V (Wide Range I/Os)	10 k	45 k	10 k	45 k
2.5 V	11 k	55 k	12 k	74 k
1.8 V	18 k	70 k	17 k	110 k
1.5 V	19 k	90 k	19 k	140 k

Notes:

1. $R_{(WEAK PULL-UP-MAX)} = (VCCI_{max} - VOH_{spec}) / I_{(WEAK PULL-UP-MIN)}$
2. $R_{(WEAK PULL-DOWN-MAX)} = (VOL_{spec}) / I_{(WEAK PULL-DOWN-MIN)}$

Table 2-21 • I/O Short Currents IOSH/IOSL

	Drive Strength	IOSH (mA)*	IOSL (mA)*
3.3 V LVTTTL / 3.3 V LVCMOS	2 mA	25	27
	4 mA	25	27
	6 mA	51	54
	8 mA	51	54
	12 mA	103	109
	16 mA	132	127
	24 mA	268	181
3.3 V LVCMOS Wide Range	100 μ A	Same as regular 3.3 V LVCMOS	Same as regular 3.3 V LVCMOS
2.5 V LVCMOS	4 mA	16	18
	8 mA	32	37
	12 mA	65	74
	16 mA	83	87
	24 mA	169	124
1.8 V LVCMOS	2 mA	9	11
	4 mA	17	22
	6 mA	35	44
	8 mA	45	51
	12 mA	91	74
	16 mA	91	74
1.5 V LVCMOS	2 mA	13	16
	4 mA	25	33
	6 mA	32	39
	8 mA	66	55
	12 mA	66	55

Notes:

1. $T_J = 100^\circ\text{C}$
2. *Applicable to 3.3 V LVCMOS Wide Range. IOSL/IOSH dependent on the I/O buffer drive strength selected for wide range applications. All LVCMOS 3.3 V software macros support LVCMOS 3.3 V wide range as specified in the JESD8b specification.*

The length of time an I/O can withstand IOSH/IOSL events depends on the junction temperature. The reliability data below is based on a 3.3 V, 36 mA I/O setting, which is the worst case for this type of analysis.

For example, at 100°C, the short current condition would have to be sustained for more than six months to cause a reliability concern. The I/O design does not contain any short circuit protection, but such protection would only be needed in extremely prolonged stress conditions.

Table 2-22 • Duration of Short Circuit Event Before Failure

Temperature	Time before Failure
-40°C	> 20 years
0°C	> 20 years
25°C	> 20 years
70°C	5 years

Table 2-22 • Duration of Short Circuit Event Before Failure (continued)

Temperature	Time before Failure
85°C	2 years
100°C	6 months

**Table 2-23 • Schmitt Trigger Input Hysteresis
Hysteresis Voltage Value (typ.) for Schmitt Mode Input Buffers**

Input Buffer Configuration	Hysteresis Value (typ.)
3.3 V LVTTTL/LVCMOS/PCI/PCI-X (Schmitt trigger mode)	240 mV
2.5 V LVCMOS (Schmitt trigger mode)	140 mV
1.8 V LVCMOS (Schmitt trigger mode)	80 mV
1.5 V LVCMOS (Schmitt trigger mode)	60 mV

Table 2-24 • I/O Input Rise Time, Fall Time, and Related I/O Reliability*

Input Buffer	Input Rise/Fall Time (min.)	Input Rise/Fall Time (max.)	Reliability
LVTTTL/LVCMOS (Schmitt trigger disabled)	No requirement	10 ns *	20 years (110°C)
LVTTTL/LVCMOS (Schmitt trigger enabled)	No requirement	No requirement, but input noise voltage cannot exceed Schmitt hysteresis.	20 years (110°C)
HSTL/SSTL/GTL	No requirement	10 ns *	10 years (100°C)
LVDS/B-LVDS/M-LVDS/LVPECL	No requirement	10 ns *	10 years (100°C)

Note: *For clock signals and similar edge-generating signals, refer to the "ProASIC3/E SSO and Pin Placement Guidelines" chapter of the *ProASIC3E FPGA Fabric User's Guide*. The maximum input rise/fall time is related to the noise induced into the input buffer trace. If the noise is low, then the rise time and fall time of input buffers can be increased beyond the maximum value. The longer the rise/fall times, the more susceptible the input signal is to the board noise. Microsemi recommends signal integrity evaluation/characterization of the system to ensure that there is no excessive noise coupling into input signals.

Single-Ended I/O Characteristics

3.3 V LVTTTL / 3.3 V LVCMOS

Low-Voltage Transistor–Transistor Logic is a general-purpose standard (EIA/JESD) for 3.3 V applications. It uses an LVTTTL input buffer and push-pull output buffer. The 3.3 V LVCMOS standard is supported as part of the 3.3 V LVTTTL support.

Table 2-25 • Minimum and Maximum DC Input and Output Levels

3.3 V LVTTTL / 3.3 V LVCMOS	VIL		VIH		VOL	VOH	IOL	IOH	IOSL	IOSH	IIL ¹	IIH ²
	Min. V	Max. V	Min., V	Max. V	Max. V	Min. V	mA	mA	Max. mA ³	Max. mA ³	μA ⁴	μA ⁴
2 mA	-0.3	0.8	2	3.6	0.4	2.4	4	4	27	25	10	10
4 mA	-0.3	0.8	2	3.6	0.4	2.4	4	4	27	25	10	10
6 mA	-0.3	0.8	2	3.6	0.4	2.4	8	8	54	51	10	10
8 mA	-0.3	0.8	2	3.6	0.4	2.4	8	8	54	51	10	10
12 mA	-0.3	0.8	2	3.6	0.4	2.4	12	12	109	103	10	10
16 mA	-0.3	0.8	2	3.6	0.4	2.4	16	16	127	132	10	10
24 mA	-0.3	0.8	2	3.6	0.4	2.4	24	24	181	268	10	10

Notes:

1. IIL is the input leakage current per I/O pin over recommended operation conditions where $-0.3\text{ V} < V_{IN} < V_{IL}$.
2. IIH is the input leakage current per I/O pin over recommended operating conditions $V_{IH} < V_{IN} < V_{CCI}$. Input current is larger when operating outside recommended ranges.
3. Currents are measured at high temperature (100°C junction temperature) and maximum voltage.
4. Currents are measured at 85°C junction temperature.
5. Software default selection highlighted in gray.

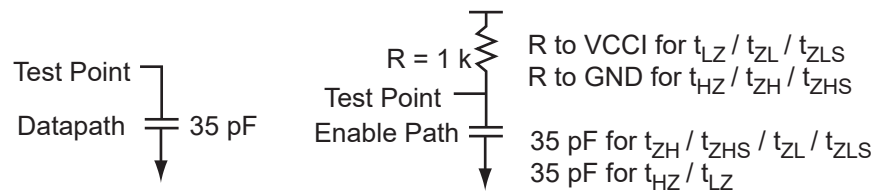

Figure 2-6 • AC Loading

Table 2-26 • 3.3 V LVTTTL / 3.3 V LVCMOS AC Waveforms, Measuring Points, and Capacitive Loads

Input Low (V)	Input High (V)	Measuring Point* (V)	VREF (typ.) (V)	C _{LOAD} (pF)
0	3.3	1.4	–	35

Note: *Measuring point = Vtrip. See Table 2-15 on page 2-19 for a complete table of trip points.

Timing Characteristics

Table 2-27 • 3.3 V LVTTTL / 3.3 V LVCMOS High Slew
Commercial-Case Conditions: $T_J = 70^\circ\text{C}$, Worst-Case $V_{CC} = 1.425\text{ V}$, Worst-Case $V_{CCI} = 3.0\text{ V}$

Drive Strength	Speed Grade	t_{DOUT}	t_{DP}	t_{DIN}	t_{PY}	t_{PYS}	t_{EOUT}	t_{ZL}	t_{ZH}	t_{LZ}	t_{HZ}	t_{ZLS}	t_{ZHS}	Units
2 mA	Std.	0.66	7.88	0.04	1.20	1.57	0.43	8.03	6.70	2.69	2.59	10.26	8.94	ns
	-1	0.56	6.71	0.04	1.02	1.33	0.36	6.83	5.70	2.29	2.20	8.73	7.60	ns
	-2	0.49	5.89	0.03	0.90	1.17	0.32	6.00	5.01	2.01	1.93	7.67	6.67	ns
4 mA	Std.	0.66	7.88	0.04	1.20	1.57	0.43	8.03	6.70	2.69	2.59	10.26	8.94	ns
	-1	0.56	6.71	0.04	1.02	1.33	0.36	6.83	5.70	2.29	2.20	8.73	7.60	ns
	-2	0.49	5.89	0.03	0.90	1.17	0.32	6.00	5.01	2.01	1.93	7.67	6.67	ns
6 mA	Std.	0.66	5.08	0.04	1.20	1.57	0.43	5.17	4.14	3.05	3.21	7.41	6.38	ns
	-1	0.56	4.32	0.04	1.02	1.33	0.36	4.40	3.52	2.59	2.73	6.30	5.43	ns
	-2	0.49	3.79	0.03	0.90	1.17	0.32	3.86	3.09	2.28	2.40	5.53	4.76	ns
8 mA	Std.	0.66	5.08	0.04	1.20	1.57	0.43	5.17	4.14	3.05	3.21	7.41	6.38	ns
	-1	0.56	4.32	0.04	1.02	1.33	0.36	4.40	3.52	2.59	2.73	6.30	5.43	ns
	-2	0.49	3.79	0.03	0.90	1.17	0.32	3.86	3.09	2.28	2.40	5.53	4.76	ns
12 mA	Std.	0.66	3.67	0.04	1.20	1.57	0.43	3.74	2.87	3.28	3.61	5.97	5.11	ns
	-1	0.56	3.12	0.04	1.02	1.33	0.36	3.18	2.44	2.79	3.07	5.08	4.34	ns
	-2	0.49	2.74	0.03	0.90	1.17	0.32	2.79	2.14	2.45	2.70	4.46	3.81	ns
16 mA	Std.	0.66	3.46	0.04	1.20	1.57	0.43	3.53	2.61	3.33	3.72	5.76	4.84	ns
	-1	0.56	2.95	0.04	1.02	1.33	0.36	3.00	2.22	2.83	3.17	4.90	4.12	ns
	-2	0.49	2.59	0.03	0.90	1.17	0.32	2.63	1.95	2.49	2.78	4.30	3.62	ns
24 mA	Std.	0.66	3.21	0.04	1.20	1.57	0.43	3.27	2.16	3.39	4.13	5.50	4.39	ns
	-1	0.56	2.73	0.04	1.02	1.33	0.36	2.78	1.83	2.88	3.51	4.68	3.74	ns
	-2	0.49	2.39	0.03	0.90	1.17	0.32	2.44	1.61	2.53	3.08	4.11	3.28	ns

Notes:

1. Software default selection highlighted in gray.
2. For specific junction temperature and voltage supply levels, refer to [Table 2-6 on page 2-6](#) for derating values.

Table 2-28 • 3.3 V LVTTTL / 3.3 V LVCMOS Low Slew
Commercial-Case Conditions: $T_J = 70^\circ\text{C}$, Worst-Case $V_{CC} = 1.425\text{ V}$, Worst-Case $V_{CCI} = 3.0\text{ V}$

Drive Strength	Speed Grade	t_{DOUT}	t_{DP}	t_{DIN}	t_{PY}	t_{PYS}	t_{EOUT}	t_{ZL}	t_{ZH}	t_{LZ}	t_{HZ}	t_{ZLS}	t_{ZHS}	Units
2 mA	Std.	0.66	11.01	0.04	1.20	1.57	0.43	11.21	9.05	2.69	2.44	13.45	11.29	ns
	-1	0.56	9.36	0.04	1.02	1.33	0.36	9.54	7.70	2.29	2.08	11.44	9.60	ns
	-2	0.49	8.22	0.03	0.90	1.17	0.32	8.37	6.76	2.01	1.82	10.04	8.43	ns
4 mA	Std.	0.66	11.01	0.04	1.20	1.57	0.43	11.21	9.05	2.69	2.44	13.45	11.29	ns
	-1	0.56	9.36	0.04	1.02	1.33	0.36	9.54	7.70	2.29	2.08	11.44	9.60	ns
	-2	0.49	8.22	0.03	0.90	1.17	0.32	8.37	6.76	2.01	1.82	10.04	8.43	ns
6 mA	Std.	0.66	7.86	0.04	1.20	1.57	0.43	8.01	6.44	3.04	3.06	10.24	8.68	ns
	-1	0.56	6.69	0.04	1.02	1.33	0.36	6.81	5.48	2.58	2.61	8.71	7.38	ns
	-2	0.49	5.87	0.03	0.90	1.17	0.32	5.98	4.81	2.27	2.29	7.65	6.48	ns
8 mA	Std.	0.66	7.86	0.04	1.20	1.57	0.43	8.01	6.44	3.04	3.06	10.24	8.68	ns
	-1	0.56	6.69	0.04	1.02	1.33	0.36	6.81	5.48	2.58	2.61	8.71	7.38	ns

Table 2-28 • 3.3 V LVTTTL / 3.3 V LVC MOS Low Slew
 Commercial-Case Conditions: $T_J = 70^\circ\text{C}$, Worst-Case $V_{CC} = 1.425\text{ V}$, Worst-Case $V_{CCI} = 3.0\text{ V}$

Drive Strength	Speed Grade	t_{DOUT}	t_{DP}	t_{DIN}	t_{PY}	t_{PYS}	t_{EOUT}	t_{ZL}	t_{ZH}	t_{LZ}	t_{HZ}	t_{ZLS}	t_{ZHS}	Units
	-2	0.49	5.87	0.03	0.90	1.17	0.32	5.98	4.81	2.27	2.29	7.65	6.48	ns
12 mA	Std.	0.66	6.03	0.04	1.20	1.57	0.43	6.14	5.02	3.28	3.47	8.37	7.26	ns
	-1	0.56	5.13	0.04	1.02	1.33	0.36	5.22	4.27	2.79	2.95	7.12	6.17	ns
	-2	0.49	4.50	0.03	0.90	1.17	0.32	4.58	3.75	2.45	2.59	6.25	5.42	ns
16 mA	Std.	0.66	5.62	0.04	1.20	1.57	0.43	5.72	4.72	3.32	3.58	7.96	6.96	ns
	-1	0.56	4.78	0.04	1.02	1.33	0.36	4.87	4.02	2.83	3.04	6.77	5.92	ns
	-2	0.49	4.20	0.03	0.90	1.17	0.32	4.27	3.53	2.48	2.67	5.94	5.20	ns
24 mA	Std.	0.66	5.24	0.04	1.20	1.57	0.43	5.34	4.69	3.39	3.96	7.58	6.93	ns
	-1	0.56	4.46	0.04	1.02	1.33	0.36	4.54	3.99	2.88	3.37	6.44	5.89	ns
	-2	0.49	3.92	0.03	0.90	1.17	0.32	3.99	3.50	2.53	2.96	5.66	5.17	ns

Note: For specific junction temperature and voltage supply levels, refer to [Table 2-6 on page 2-6](#) for derating values.

3.3 V LVCMOS Wide Range

Table 2-29 • Minimum and Maximum DC Input and Output Levels

3.3 V LVCMOS Wide Range	Equivalent Software Default Drive	VIL		VIH		VOL	VOH	IOL	IOH	IOSL	IOSH	IIL ²	IIH ³
		Min. V	Max. V	Min. V	Max. V	Max. V	Min. V	μA	μA	Max. mA ⁴	Max. mA ⁴	μA ⁵	μA ⁵
100 μA	2 mA	-0.3	0.8	2	3.6	0.2	VDD - 0.2	100	100	27	25	10	10
100 μA	4 mA	-0.3	0.8	2	3.6	0.2	VDD - 0.2	100	100	27	25	10	10
100 μA	6 mA	-0.3	0.8	2	3.6	0.2	VDD - 0.2	100	100	54	51	10	10
100 μA	8 mA	-0.3	0.8	2	3.6	0.2	VDD - 0.2	100	100	54	51	10	10
100 μA	12 mA	-0.3	0.8	2	3.6	0.2	VDD - 0.2	100	100	109	103	10	10
100 μA	16 mA	-0.3	0.8	2	3.6	0.2	VDD - 0.2	100	100	127	132	10	10
100 μA	24 mA	-0.3	0.8	2	3.6	0.2	VDD - 0.2	100	100	181	268	10	10

Notes:

1. The minimum drive strength for any LVCMOS 3.3 V software configuration when run in wide range is ±100 μA. Drive strength displayed in the software is supported for normal range only. For a detailed I/V curve, refer to the IBIS models.
2. IIL is the input leakage current per I/O pin over recommended operation conditions where -0.3 V < VIN < VIL.
3. IIH is the input leakage current per I/O pin over recommended operating conditions VIH < VIN < VCCI. Input current is larger when operating outside recommended ranges.
4. Currents are measured at high temperature (100°C junction temperature) and maximum voltage.
5. Currents are measured at 85°C junction temperature.
6. Software default selection highlighted in gray.

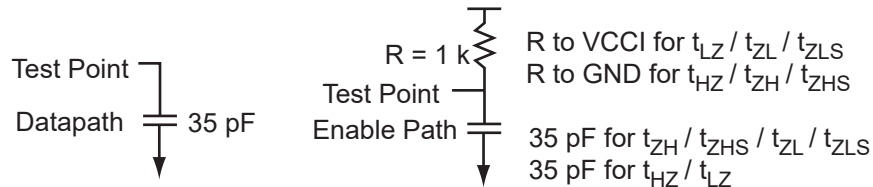

Figure 2-7 • AC Loading

Table 2-30 • 3.3 V LVCMOS Wide Range AC Waveforms, Measuring Points, and Capacitive Loads

Input Low (V)	Input High (V)	Measuring Point* (V)	VREF (typ.) (V)	C _{LOAD} (pF)
0	3.3	1.4	-	35

Note: *Measuring point = Vtrip. See Table 2-15 on page 2-19 for a complete table of trip points.

Timing Characteristics

Table 2-31 • 3.3 V LVC MOS Wide Range High Slew
 Commercial-Case Conditions: $T_J = 70^\circ\text{C}$, Worst-Case $V_{CC} = 1.425\text{ V}$, Worst-Case $V_{CCI} = 2.7\text{ V}$

Drive Strength	Equivalent Software Default Drive Strength Option ¹	Speed Grade	t_{DOUT}	t_{DP}	t_{DIN}	t_{PY}	t_{PYS}	t_{EOUT}	t_{ZL}	t_{ZH}	t_{LZ}	t_{HZ}	t_{ZLS}	t_{ZHS}	Units
100 μA	4 mA	Std.	0.66	12.19	0.04	1.83	2.38	0.43	12.19	10.17	4.16	4.00	15.58	13.57	ns
		-1	0.56	10.37	0.04	1.55	2.02	0.36	10.37	8.66	3.54	3.41	13.26	11.54	ns
		-2	0.49	9.10	0.03	1.36	1.78	0.32	9.10	7.60	3.11	2.99	11.64	10.13	ns
100 μA	8 mA	Std.	0.66	7.85	0.04	1.83	2.38	0.43	7.85	6.29	4.71	4.97	11.24	9.68	ns
		-1	0.56	6.68	0.04	1.55	2.02	0.36	6.68	5.35	4.01	4.22	9.57	8.24	ns
		-2	0.49	5.86	0.03	1.36	1.78	0.32	5.86	4.70	3.52	3.71	8.40	7.23	ns
100 μA	12 mA	Std.	0.66	5.67	0.04	1.83	2.38	0.43	5.67	4.36	5.06	5.59	9.07	7.75	ns
		-1	0.56	4.82	0.04	1.55	2.02	0.36	4.82	3.71	4.31	4.75	7.71	6.59	ns
		-2	0.49	4.24	0.03	1.36	1.78	0.32	4.24	3.25	3.78	4.17	6.77	5.79	ns
100 μA	16 mA	Std.	0.66	5.35	0.04	1.83	2.38	0.43	5.35	3.96	5.15	5.76	8.75	7.35	ns
		-1	0.56	4.55	0.04	1.55	2.02	0.36	4.55	3.36	4.38	4.90	7.44	6.25	ns
		-2	0.49	4.00	0.03	1.36	1.78	0.32	4.00	2.95	3.85	4.30	6.53	5.49	ns
100 μA	24 mA	Std.	0.66	4.96	0.04	1.83	2.38	0.43	4.96	3.27	5.23	6.38	8.35	6.67	ns
		-1	0.56	4.22	0.04	1.55	2.02	0.36	4.22	2.78	4.45	5.43	7.11	5.67	ns
		-2	0.49	3.70	0.03	1.36	1.78	0.32	3.70	2.44	3.91	4.76	6.24	4.98	ns

Notes:

1. The minimum drive strength for any LVC MOS 3.3 V software configuration when run in wide range is $\pm 100\ \mu\text{A}$. Drive strength displayed in the software is supported for normal range only. For a detailed I/V curve, refer to the IBIS models.
2. Software default selection highlighted in gray.
3. For specific junction temperature and voltage supply levels, refer to Table 2-6 on page 2-6 for derating values.

Table 2-32 • 3.3 V LVCMOS Wide Range Low Slew
Commercial-Case Conditions: $T_J = 70^\circ\text{C}$, Worst-Case $V_{CC} = 1.425\text{ V}$, Worst-Case $V_{CCI} = 2.7\text{ V}$

Drive Strength	Equivalent Software Default Drive Strength Option ¹	Speed Grade	t_{DOUT}	t_{DP}	t_{DIN}	t_{PY}	t_{PYS}	t_{EOUT}	t_{ZL}	t_{ZH}	t_{LZ}	t_{HZ}	t_{ZLS}	t_{ZHS}	Units
			Std.	-1	-2	Std.	-1	-2	Std.	-1	-2	Std.	-1	-2	
100 μA	4 mA	Std.	0.66	17.02	0.04	1.83	2.38	0.43	17.02	13.74	4.16	3.78	20.42	17.14	ns
		-1	0.56	14.48	0.04	1.55	2.02	0.36	14.48	11.69	3.54	3.21	17.37	14.58	ns
		-2	0.49	12.71	0.03	1.36	1.78	0.32	12.71	10.26	3.11	2.82	15.25	12.80	ns
100 μA	8 mA	Std.	0.66	12.16	0.04	1.83	2.38	0.43	12.16	9.78	4.70	4.74	15.55	13.17	ns
		-1	0.56	10.34	0.04	1.55	2.02	0.36	10.34	8.32	4.00	4.03	13.23	11.20	ns
		-2	0.49	9.08	0.03	1.36	1.78	0.32	9.08	7.30	3.51	3.54	11.61	9.84	ns
100 μA	12 mA	Std.	0.66	9.32	0.04	1.83	2.38	0.43	9.32	7.62	5.06	5.36	12.71	11.02	ns
		-1	0.56	7.93	0.04	1.55	2.02	0.36	7.93	6.48	4.31	4.56	10.81	9.37	ns
		-2	0.49	6.96	0.03	1.36	1.78	0.32	6.96	5.69	3.78	4.00	9.49	8.23	ns
100 μA	16 mA	Std.	0.66	8.69	0.04	1.83	2.38	0.43	8.69	7.17	5.14	5.53	12.08	10.57	ns
		-1	0.56	7.39	0.04	1.55	2.02	0.36	7.39	6.10	4.37	4.71	10.28	8.99	ns
		-2	0.49	6.49	0.03	1.36	1.78	0.32	6.49	5.36	3.83	4.13	9.02	7.89	ns
100 μA	24 mA	Std.	0.66	8.11	0.04	1.83	2.38	0.43	8.11	7.13	5.23	6.13	11.50	10.52	ns
		-1	0.56	6.90	0.04	1.55	2.02	0.36	6.90	6.06	4.45	5.21	9.78	8.95	ns
		-2	0.49	6.05	0.03	1.36	1.78	0.32	6.05	5.32	3.91	4.57	8.59	7.86	ns

Notes:

1. The minimum drive strength for any LVCMOS 3.3 V software configuration when run in wide range is $\pm 100\ \mu\text{A}$. Drive strength displayed in the software is supported for normal range only. For a detailed I/V curve, refer to the IBIS models.
2. Software default selection highlighted in gray.
3. For specific junction temperature and voltage supply levels, refer to [Table 2-6 on page 2-6](#) for derating values.

2.5 V LVCMOS

Low-Voltage CMOS for 2.5 V is an extension of the LVCMOS standard (JESD8-5) used for general-purpose 2.5 V applications.

Table 2-33 • Minimum and Maximum DC Input and Output Levels

2.5 V LVCMOS	VIL		VIH		VOL	VOH	IOL	IOH	IOSL	IOSH	IIL ¹	IIH ²
	Min. V	Max. V	Min. V	Max. V	Max., V	Min. V	mA	mA	Max. mA ³	Max. mA ³	μA ⁴	μA ⁴
4 mA	-0.3	0.7	1.7	3.6	0.7	1.7	4	4	18	16	10	10
8 mA	-0.3	0.7	1.7	3.6	0.7	1.7	8	8	37	32	10	10
12 mA	-0.3	0.7	1.7	3.6	0.7	1.7	12	12	74	65	10	10
16 mA	-0.3	0.7	1.7	3.6	0.7	1.7	16	16	87	83	10	10
24 mA	-0.3	0.7	1.7	3.6	0.7	1.7	24	24	124	169	10	10

Notes:

1. IIL is the input leakage current per I/O pin over recommended operation conditions where $-0.3\text{ V} < V_{IN} < V_{IL}$.
2. IIH is the input leakage current per I/O pin over recommended operating conditions $V_{IH} < V_{IN} < V_{CCI}$. Input current is larger when operating outside recommended ranges.
3. Currents are measured at high temperature (100°C junction temperature) and maximum voltage.
4. Currents are measured at 85°C junction temperature.
5. Software default selection highlighted in gray.

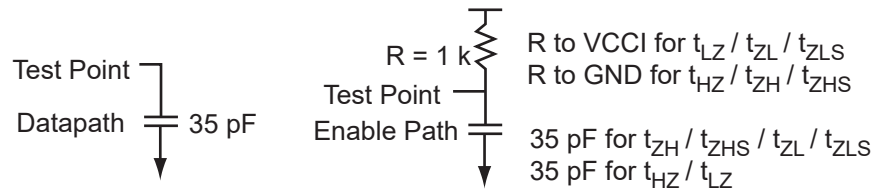

Figure 2-8 • AC Loading

Table 2-34 • AC Waveforms, Measuring Points, and Capacitive Loads

Input Low (V)	Input High (V)	Measuring Point* (V)	VREF (typ.) (V)	C _{LOAD} (pF)
0	2.5	1.2	–	35

Note: *Measuring point = Vtrip. See Table 2-15 on page 2-19 for a complete table of trip points.

Timing Characteristics

Table 2-35 • 2.5 V LVCMOS High Slew

Commercial-Case Conditions: $T_J = 70^\circ\text{C}$, Worst-Case $V_{CC} = 1.425\text{ V}$, Worst-Case $V_{CCI} = 2.3\text{ V}$

Drive Strength	Speed Grade	t_{DOUT}	t_{DP}	t_{DIN}	t_{PY}	t_{PYS}	t_{EOUT}	t_{ZL}	t_{ZH}	t_{LZ}	t_{HZ}	t_{ZLS}	t_{ZHS}	Units
4 mA	Std.	0.66	8.82	0.04	1.51	1.66	0.43	8.13	8.82	2.72	2.29	10.37	11.05	ns
	-1	0.56	7.50	0.04	1.29	1.41	0.36	6.92	7.50	2.31	1.95	8.82	9.40	ns
	-2	0.49	6.58	0.03	1.13	1.24	0.32	6.07	6.58	2.03	1.71	7.74	8.25	ns
8 mA	Std.	0.66	5.27	0.04	1.51	1.66	0.43	5.27	5.27	3.10	3.03	7.50	7.51	ns
	-1	0.56	4.48	0.04	1.29	1.41	0.36	4.48	4.48	2.64	2.58	6.38	6.38	ns
	-2	0.49	3.94	0.03	1.13	1.24	0.32	3.93	3.94	2.32	2.26	5.60	5.61	ns
12 mA	Std.	0.66	3.74	0.04	1.51	1.66	0.43	3.81	3.49	3.37	3.49	6.05	5.73	ns
	-1	0.56	3.18	0.04	1.29	1.41	0.36	3.24	2.97	2.86	2.97	5.15	4.87	ns
	-2	0.49	2.80	0.03	1.13	1.24	0.32	2.85	2.61	2.51	2.61	4.52	4.28	ns
16 mA	Std.	0.66	3.53	0.04	1.51	1.66	0.43	3.59	3.12	3.42	3.62	5.83	5.35	ns
	-1	0.56	3.00	0.04	1.29	1.41	0.36	3.06	2.65	2.91	3.08	4.96	4.55	ns
	-2	0.49	2.63	0.03	1.13	1.24	0.32	2.68	2.33	2.56	2.71	4.35	4.00	ns
24 mA	Std.	0.66	3.26	0.04	1.51	1.66	0.43	3.32	2.48	3.49	4.11	5.56	4.72	ns
	-1	0.56	2.77	0.04	1.29	1.41	0.36	2.83	2.11	2.97	3.49	4.73	4.01	ns
	-2	0.49	2.44	0.03	1.13	1.24	0.32	2.48	1.85	2.61	3.07	4.15	3.52	ns

Notes:

1. Software default selection highlighted in gray.
2. For specific junction temperature and voltage supply levels, refer to Table 2-6 on page 2-6 for derating values.

Table 2-36 • 2.5 V LVCMOS Low Slew
Commercial-Case Conditions: $T_J = 70^\circ\text{C}$, Worst-Case $V_{CC} = 1.425\text{ V}$, Worst-Case $V_{CCI} = 2.3\text{ V}$

Drive Strength	Speed Grade	t_{DOUT}	t_{DP}	t_{DIN}	t_{PY}	t_{PYS}	t_{EOUT}	t_{ZL}	t_{ZH}	t_{LZ}	t_{HZ}	t_{ZLS}	t_{ZHS}	Units
4 mA	Std.	0.66	12.00	0.04	1.51	1.66	0.43	12.23	11.61	2.72	2.20	14.46	13.85	ns
	-1	0.56	10.21	0.04	1.29	1.41	0.36	10.40	9.88	2.31	1.87	12.30	11.78	ns
	-2	0.49	8.96	0.03	1.13	1.24	0.32	9.13	8.67	2.03	1.64	10.80	10.34	ns
8 mA	Std.	0.66	8.73	0.04	1.51	1.66	0.43	8.89	8.01	3.10	2.93	11.13	10.25	ns
	-1	0.56	7.43	0.04	1.29	1.41	0.36	7.57	6.82	2.64	2.49	9.47	8.72	ns
	-2	0.49	6.52	0.03	1.13	1.24	0.32	6.64	5.98	2.32	2.19	8.31	7.65	ns
12 mA	Std.	0.66	6.77	0.04	1.51	1.66	0.43	6.90	6.11	3.37	3.39	9.14	8.34	ns
	-1	0.56	5.76	0.04	1.29	1.41	0.36	5.87	5.20	2.86	2.89	7.77	7.10	ns
	-2	0.49	5.06	0.03	1.13	1.24	0.32	5.15	4.56	2.51	2.53	6.82	6.23	ns
16 mA	Std.	0.66	6.31	0.04	1.51	1.66	0.43	6.42	5.73	3.42	3.52	8.66	7.96	ns
	-1	0.56	5.37	0.04	1.29	1.41	0.36	5.46	4.87	2.91	3.00	7.37	6.77	ns
	-2	0.49	4.71	0.03	1.13	1.24	0.32	4.80	4.28	2.56	2.63	6.47	5.95	ns
24 mA	Std.	0.66	5.93	0.04	1.51	1.66	0.43	6.04	5.70	3.49	4.00	8.28	7.94	ns
	-1	0.56	5.05	0.04	1.29	1.41	0.36	5.14	4.85	2.97	3.40	7.04	6.75	ns
	-2	0.49	4.43	0.03	1.13	1.24	0.32	4.51	4.26	2.61	2.99	6.18	5.93	ns

Note: For specific junction temperature and voltage supply levels, refer to [Table 2-6 on page 2-6](#) for derating values.

1.8 V LVCMOS

Low-Voltage CMOS for 1.8 V is an extension of the LVCMOS standard (JESD8-5) used for general-purpose 1.8 V applications. It uses a 1.8 V input buffer and a push-pull output buffer.

Table 2-37 • Minimum and Maximum DC Input and Output Levels

1.8 V LVCMOS Drive Strength	VIL		VIH		VOL	VOH	IOL	IOH	IOSL	IOSH	IIL ¹	IIH ²
	Min. V	Max. V	Min. V	Max. V	Max. V	Min. V	mA	mA	Max. mA ³	Max. mA ³	μA ⁴	μA ⁴
2 mA	-0.3	0.35 * VCCI	0.65 * VCCI	3.6	0.45	VCCI - 0.45	2	2	11	9	10	10
4 mA	-0.3	0.35 * VCCI	0.65 * VCCI	3.6	0.45	VCCI - 0.45	4	4	22	17	10	10
6 mA	-0.3	0.35 * VCCI	0.65 * VCCI	3.6	0.45	VCCI - 0.45	6	6	44	35	10	10
8 mA	-0.3	0.35 * VCCI	0.65 * VCCI	3.6	0.45	VCCI - 0.45	8	8	51	45	10	10
12 mA	-0.3	0.35 * VCCI	0.65 * VCCI	3.6	0.45	VCCI - 0.45	12	12	74	91	10	10
16 mA	-0.3	0.35 * VCCI	0.65 * VCCI	3.6	0.45	VCCI - 0.45	16	16	74	91	10	10

Notes:

1. IIL is the input leakage current per I/O pin over recommended operation conditions where $-0.3\text{ V} < V_{IN} < V_{IL}$.
2. IIH is the input leakage current per I/O pin over recommended operating conditions $V_{IH} < V_{IN} < V_{CCI}$. Input current is larger when operating outside recommended ranges.
3. Currents are measured at high temperature (100°C junction temperature) and maximum voltage.
4. Currents are measured at 85°C junction temperature.
5. Software default selection highlighted in gray.

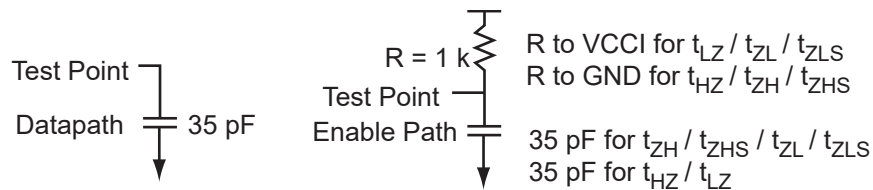

Figure 2-9 • AC Loading

Table 2-38 • AC Waveforms, Measuring Points, and Capacitive Loads

Input Low (V)	Input High (V)	Measuring Point* (V)	VREF (typ.) (V)	C _{LOAD} (pF)
0	1.8	0.9	-	35

Note: *Measuring point = Vtrip. See Table 2-15 on page 2-19 for a complete table of trip points.

Timing Characteristics

Table 2-39 • 1.8 V LVCMOS High Slew

Commercial-Case Conditions: $T_J = 70^\circ\text{C}$, Worst-Case $V_{CC} = 1.425\text{ V}$, Worst-Case $V_{CCI} = 1.7\text{ V}$

Drive Strength	Speed Grade	t_{DOUT}	t_{DP}	t_{DIN}	t_{PY}	t_{PYS}	t_{EOUT}	t_{ZL}	t_{ZH}	t_{LZ}	t_{HZ}	t_{ZLS}	t_{ZHS}	Units
2 mA	Std.	0.66	12.10	0.04	1.45	1.91	0.43	9.59	12.10	2.78	1.64	11.83	14.34	ns
	-1	0.56	10.30	0.04	1.23	1.62	0.36	8.16	10.30	2.37	1.39	10.06	12.20	ns
	-2	0.49	9.04	0.03	1.08	1.42	0.32	7.16	9.04	2.08	1.22	8.83	10.71	ns
4 mA	Std.	0.66	7.05	0.04	1.45	1.91	0.43	6.20	7.05	3.25	2.86	8.44	9.29	ns
	-1	0.56	6.00	0.04	1.23	1.62	0.36	5.28	6.00	2.76	2.44	7.18	7.90	ns
	-2	0.49	5.27	0.03	1.08	1.42	0.32	4.63	5.27	2.43	2.14	6.30	6.94	ns
6 mA	Std.	0.66	4.52	0.04	1.45	1.91	0.43	4.47	4.52	3.57	3.47	6.70	6.76	ns
	-1	0.56	3.85	0.04	1.23	1.62	0.36	3.80	3.85	3.04	2.95	5.70	5.75	ns
	-2	0.49	3.38	0.03	1.08	1.42	0.32	3.33	3.38	2.66	2.59	5.00	5.05	ns
8 mA	Std.	0.66	4.12	0.04	1.45	1.91	0.43	4.20	3.99	3.63	3.62	6.43	6.23	ns
	-1	0.56	3.51	0.04	1.23	1.62	0.36	3.57	3.40	3.09	3.08	5.47	5.30	ns
	-2	0.49	3.08	0.03	1.08	1.42	0.32	3.14	2.98	2.71	2.71	4.81	4.65	ns
12 mA	Std.	0.66	3.80	0.04	1.45	1.91	0.43	3.87	3.09	3.73	4.24	6.10	5.32	ns
	-1	0.56	3.23	0.04	1.23	1.62	0.36	3.29	2.63	3.18	3.60	5.19	4.53	ns
	-2	0.49	2.83	0.03	1.08	1.42	0.32	2.89	2.31	2.79	3.16	4.56	3.98	ns
16 mA	Std.	0.66	3.80	0.04	1.45	1.91	0.43	3.87	3.09	3.73	4.24	6.10	5.32	ns
	-1	0.56	3.23	0.04	1.23	1.62	0.36	3.29	2.63	3.18	3.60	5.19	4.53	ns
	-2	0.49	2.83	0.03	1.08	1.42	0.32	2.89	2.31	2.79	3.16	4.56	3.98	ns

Notes:

1. Software default selection highlighted in gray.
2. For specific junction temperature and voltage supply levels, refer to [Table 2-6 on page 2-6](#) for derating values.

Table 2-40 • 1.8 V LVCMOS Low Slew
Commercial-Case Conditions: $T_J = 70^\circ\text{C}$, Worst-Case $V_{CC} = 1.425\text{ V}$, Worst-Case $V_{CCI} = 1.7\text{ V}$

Drive Strength	Speed Grade	t_{DOUT}	t_{DP}	t_{DIN}	t_{PY}	t_{PYS}	t_{EOUT}	t_{ZL}	t_{ZH}	t_{LZ}	t_{HZ}	t_{ZLS}	t_{ZHS}	Units
2 mA	Std.	0.66	15.84	0.04	1.45	1.91	0.43	15.65	15.84	2.78	1.58	17.89	18.07	ns
	-1	0.56	13.47	0.04	1.23	1.62	0.36	13.31	13.47	2.37	1.35	15.22	15.37	ns
	-2	0.49	11.83	0.03	1.08	1.42	0.32	11.69	11.83	2.08	1.18	13.36	13.50	ns
4 mA	Std.	0.66	11.39	0.04	1.45	1.91	0.43	11.60	10.76	3.26	2.77	13.84	12.99	ns
	-1	0.56	9.69	0.04	1.23	1.62	0.36	9.87	9.15	2.77	2.36	11.77	11.05	ns
	-2	0.49	8.51	0.03	1.08	1.42	0.32	8.66	8.03	2.43	2.07	10.33	9.70	ns
6 mA	Std.	0.66	8.97	0.04	1.45	1.91	0.43	9.14	8.10	3.57	3.36	11.37	10.33	ns
	-1	0.56	7.63	0.04	1.23	1.62	0.36	7.77	6.89	3.04	2.86	9.67	8.79	ns
	-2	0.49	6.70	0.03	1.08	1.42	0.32	6.82	6.05	2.66	2.51	8.49	7.72	ns
8 mA	Std.	0.66	8.35	0.04	1.45	1.91	0.43	8.50	7.59	3.64	3.52	10.74	9.82	ns
	-1	0.56	7.10	0.04	1.23	1.62	0.36	7.23	6.45	3.10	3.00	9.14	8.35	ns
	-2	0.49	6.24	0.03	1.08	1.42	0.32	6.35	5.66	2.72	2.63	8.02	7.33	ns
12 mA	Std.	0.66	7.94	0.04	1.45	1.91	0.43	8.09	7.56	3.74	4.11	10.32	9.80	ns
	-1	0.56	6.75	0.04	1.23	1.62	0.36	6.88	6.43	3.18	3.49	8.78	8.33	ns
	-2	0.49	5.93	0.03	1.08	1.42	0.32	6.04	5.65	2.79	3.07	7.71	7.32	ns
16 mA	Std.	0.66	7.94	0.04	1.45	1.91	0.43	8.09	7.56	3.74	4.11	10.32	9.80	ns
	-1	0.56	6.75	0.04	1.23	1.62	0.36	6.88	6.43	3.18	3.49	8.78	8.33	ns
	-2	0.49	5.93	0.03	1.08	1.42	0.32	6.04	5.65	2.79	3.07	7.71	7.32	ns

Note: For specific junction temperature and voltage supply levels, refer to [Table 2-6 on page 2-6](#) for derating values.

1.5 V LVCMOS (JESD8-11)

Low-Voltage CMOS for 1.5 V is an extension of the LVCMOS standard (JESD8-5) used for general-purpose 1.5 V applications. It uses a 1.5 V input buffer and a push-pull output buffer.

Table 2-41 • Minimum and Maximum DC Input and Output Levels

1.5 V LVCMOS	VIL		VIH		VOL	VOH	IOL	IOH	IOSL	IOSH	IIL ¹	IIH ²
	Min. V	Max. V	Min. V	Max. V	Max. V	Min. V	mA	mA	Max. mA ³	Max. mA ³	μA ⁴	μA ⁴
2 mA	-0.3	0.30 * VCCI	0.7 * VCCI	3.6	0.25 * VCCI	0.75 * VCCI	2	2	16	13	10	10
4 mA	-0.3	0.30 * VCCI	0.7 * VCCI	3.6	0.25 * VCCI	0.75 * VCCI	4	4	33	25	10	10
6 mA	-0.3	0.30 * VCCI	0.7 * VCCI	3.6	0.25 * VCCI	0.75 * VCCI	6	6	39	32	10	10
8 mA	-0.3	0.30 * VCCI	0.7 * VCCI	3.6	0.25 * VCCI	0.75 * VCCI	8	8	55	66	10	10
12 mA	-0.3	0.30 * VCCI	0.7 * VCCI	3.6	0.25 * VCCI	0.75 * VCCI	12	12	55	66	10	10

Notes:

1. IIL is the input leakage current per I/O pin over recommended operation conditions where $-0.3\text{ V} < V_{IN} < V_{IL}$.
2. IIH is the input leakage current per I/O pin over recommended operating conditions $V_{IH} < V_{IN} < V_{CCI}$. Input current is larger when operating outside recommended ranges.
3. Currents are measured at high temperature (100°C junction temperature) and maximum voltage.
4. Currents are measured at 85°C junction temperature.
5. Software default selection highlighted in gray.

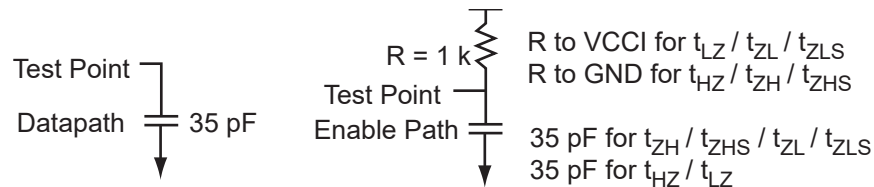

Figure 2-10 • AC Loading

Table 2-42 • AC Waveforms, Measuring Points, and Capacitive Loads

Input Low (V)	Input High (V)	Measuring Point* (V)	VREF (typ.) (V)	C _{LOAD} (pF)
0	1.5	0.75	-	35

Note: *Measuring point = Vtrip. See Table 2-15 on page 2-19 for a complete table of trip points.

Timing Characteristics

Table 2-43 • 1.5 V LVCMOS High Slew

Commercial-Case Conditions: $T_J = 70^\circ\text{C}$, Worst-Case $V_{CC} = 1.425\text{ V}$, Worst-Case $V_{CCI} = 1.4\text{ V}$

Drive Strength	Speed Grade	t_{DOUT}	t_{DP}	t_{DIN}	t_{PY}	t_{PYS}	t_{EOUT}	t_{ZL}	t_{ZH}	t_{LZ}	t_{HZ}	t_{ZLS}	t_{ZHS}	Units
2 mA	Std.	0.66	8.53	0.04	1.70	2.14	0.43	7.26	8.53	3.39	2.79	9.50	10.77	ns
	-1	0.56	7.26	0.04	1.44	1.82	0.36	6.18	7.26	2.89	2.37	8.08	9.16	ns
	-2	0.49	6.37	0.03	1.27	1.60	0.32	5.42	6.37	2.53	2.08	7.09	8.04	ns
4 mA	Std.	0.66	5.41	0.04	1.70	2.14	0.43	5.22	5.41	3.75	3.48	7.45	7.65	ns
	-1	0.56	4.60	0.04	1.44	1.82	0.36	4.44	4.60	3.19	2.96	6.34	6.50	ns
	-2	0.49	4.04	0.03	1.27	1.60	0.32	3.89	4.04	2.80	2.60	5.56	5.71	ns
6 mA	Std.	0.66	4.80	0.04	1.70	2.14	0.43	4.89	4.75	3.83	3.67	7.13	6.98	ns
	-1	0.56	4.09	0.04	1.44	1.82	0.36	4.16	4.04	3.26	3.12	6.06	5.94	ns
	-2	0.49	3.59	0.03	1.27	1.60	0.32	3.65	3.54	2.86	2.74	5.32	5.21	ns
8 mA	Std.	0.66	4.42	0.04	1.70	2.14	0.43	4.50	3.62	3.96	4.37	6.74	5.86	ns
	-1	0.56	3.76	0.04	1.44	1.82	0.36	3.83	3.08	3.37	3.72	5.73	4.98	ns
	-2	0.49	3.30	0.03	1.27	1.60	0.32	3.36	2.70	2.96	3.27	5.03	4.37	ns
12 mA	Std.	0.66	4.42	0.04	1.70	2.14	0.43	4.50	3.62	3.96	4.37	6.74	5.86	ns
	-1	0.56	3.76	0.04	1.44	1.82	0.36	3.83	3.08	3.37	3.72	5.73	4.98	ns
	-2	0.49	3.30	0.03	1.27	1.60	0.32	3.36	2.70	2.96	3.27	5.03	4.37	ns

Notes:

1. Software default selection highlighted in gray.
2. For specific junction temperature and voltage supply levels, refer to [Table 2-6 on page 2-6](#) for derating values.

Table 2-44 • 1.5 V LVCMOS Low Slew

Commercial-Case Conditions: $T_J = 70^\circ\text{C}$, Worst-Case $V_{CC} = 1.425\text{ V}$, Worst-Case $V_{CCI} = 1.4\text{ V}$

Drive Strength	Speed Grade	t_{DOUT}	t_{DP}	t_{DIN}	t_{PY}	t_{PYS}	t_{EOUT}	t_{ZL}	t_{ZH}	t_{LZ}	t_{HZ}	t_{ZLS}	t_{ZHS}	Units
2 mA	Std.	0.66	14.11	0.04	1.70	2.14	0.43	14.37	13.14	3.40	2.68	16.61	15.37	ns
	-1	0.56	12.00	0.04	1.44	1.82	0.36	12.22	11.17	2.90	2.28	14.13	13.08	ns
	-2	0.49	10.54	0.03	1.27	1.60	0.32	10.73	9.81	2.54	2.00	12.40	11.48	ns
4 mA	Std.	0.66	11.23	0.04	1.70	2.14	0.43	11.44	9.87	3.77	3.36	13.68	12.10	ns
	-1	0.56	9.55	0.04	1.44	1.82	0.36	9.73	8.39	3.21	2.86	11.63	10.29	ns
	-2	0.49	8.39	0.03	1.27	1.60	0.32	8.54	7.37	2.81	2.51	10.21	9.04	ns
6 mA	Std.	0.66	10.45	0.04	1.70	2.14	0.43	10.65	9.24	3.84	3.55	12.88	11.48	ns
	-1	0.56	8.89	0.04	1.44	1.82	0.36	9.06	7.86	3.27	3.02	10.96	9.76	ns
	-2	0.49	7.81	0.03	1.27	1.60	0.32	7.95	6.90	2.87	2.65	9.62	8.57	ns
8 mA	Std.	0.66	10.02	0.04	1.70	2.14	0.43	10.20	9.23	3.97	4.22	12.44	11.47	ns
	-1	0.56	8.52	0.04	1.44	1.82	0.36	8.68	7.85	3.38	3.59	10.58	9.75	ns
	-2	0.49	7.48	0.03	1.27	1.60	0.32	7.62	6.89	2.97	3.15	9.29	8.56	ns
12 mA	Std.	0.66	10.02	0.04	1.70	2.14	0.43	10.20	9.23	3.97	4.22	12.44	11.47	ns
	-1	0.56	8.52	0.04	1.44	1.82	0.36	8.68	7.85	3.38	3.59	10.58	9.75	ns
	-2	0.49	7.48	0.03	1.27	1.60	0.32	7.62	6.89	2.97	3.15	9.29	8.56	ns

Note: For specific junction temperature and voltage supply levels, refer to [Table 2-6 on page 2-6](#) for derating values.

3.3 V PCI, 3.3 V PCI-X

Peripheral Component Interface for 3.3 V standard specifies support for 33 MHz and 66 MHz PCI Bus applications.

Table 2-45 • Minimum and Maximum DC Input and Output Levels

3.3 V PCI/PCI-X	VIL		VIH		VOL	VOH	IOL	IOH	IOSL	IOSH	IIL ¹	IIH ²
	Min. V	Max. V	Min. V	Max. V	Max. V	Min. V	mA	mA	Max. mA ³	Max. mA ³	μA ⁴	μA ⁴
Per PCI specification	Per PCI curves										10	10

Notes:

1. IIL is the input leakage current per I/O pin over recommended operation conditions where $-0.3\text{ V} < V_{IN} < V_{IL}$.
2. IIH is the input leakage current per I/O pin over recommended operating conditions $V_{IH} < V_{IN} < V_{CCI}$. Input current is larger when operating outside recommended ranges.
3. Currents are measured at high temperature (100°C junction temperature) and maximum voltage.
4. Currents are measured at 85°C junction temperature.

AC loadings are defined per the PCI/PCI-X specifications for the datapath; Microsemi loadings for enable path characterization are described in [Figure 2-11](#).

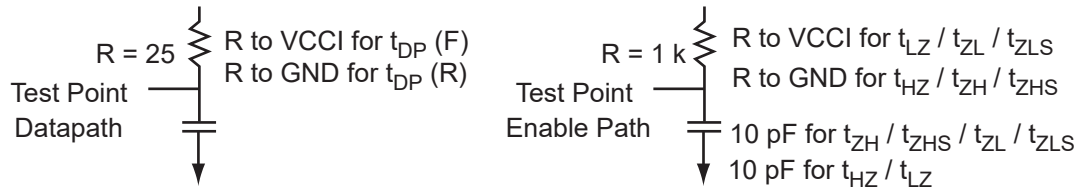

Figure 2-11 • AC Loading

AC loadings are defined per PCI/PCI-X specifications for the datapath; Microsemi loading for tristate is described in [Table 2-46](#).

Table 2-46 • AC Waveforms, Measuring Points, and Capacitive Loads

Input Low (V)	Input High (V)	Measuring Point* (V)	VREF (typ.) (V)	C _{LOAD} (pF)
0	3.3	0.285 * VCCI for t _{DP(R)} 0.615 * VCCI for t _{DP(F)}	–	10

Note: *Measuring point = Vtrip. See [Table 2-15 on page 2-19](#) for a complete table of trip points.

Timing Characteristics

Table 2-47 • 3.3 V PCI/PCI-X

Commercial-Case Conditions: $T_J = 70^\circ\text{C}$, Worst-Case $V_{CC} = 1.425\text{ V}$, Worst-Case $V_{CCI} = 3.0\text{ V}$

Speed Grade	t_{DOUT}	t_{DP}	t_{DIN}	t_{PY}	t_{PYS}	t_{EOUT}	t_{ZL}	t_{ZH}	t_{LZ}	t_{HZ}	t_{ZLS}	t_{ZHS}	Units
Std.	0.66	2.81	0.04	1.05	1.67	0.43	2.86	2.00	3.28	3.61	5.09	4.23	ns
-1	0.56	2.39	0.04	0.89	1.42	0.36	2.43	1.70	2.79	3.07	4.33	3.60	ns
-2	0.49	2.09	0.03	0.78	1.25	0.32	2.13	1.49	2.45	2.70	3.80	3.16	ns

Note: For specific junction temperature and voltage supply levels, refer to Table 2-6 on page 2-6 for derating values.

Voltage-Referenced I/O Characteristics

3.3 V GTL

Gunning Transceiver Logic is a high-speed bus standard (JESD8-3). It provides a differential amplifier input buffer and an open-drain output buffer. The V_{CCI} pin should be connected to 3.3 V.

Table 2-48 • Minimum and Maximum DC Input and Output Levels

3.3 V GTL	VIL		VIH		VOL	VOH	IOL	IOH	IOSL	IOSH	IIL	IIH
Drive Strength	Min. V	Max. V	Min. V	Max. V	Max. V	Min. V	mA	mA	Max. mA ¹	Max. mA ¹	μA^2	μA^2
20 mA ³	-0.3	$V_{REF} - 0.05$	$V_{REF} + 0.05$	3.6	0.4	-	20	20	181	268	10	10

Notes:

1. Currents are measured at high temperature (100°C junction temperature) and maximum voltage.
2. Currents are measured at 85°C junction temperature.
3. Output drive strength is below JEDEC specification.

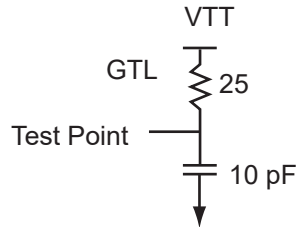

Figure 2-12 • AC Loading

Table 2-49 • AC Waveforms, Measuring Points, and Capacitive Loads

Input Low (V)	Input High (V)	Measuring Point* (V)	V_{REF} (typ.) (V)	V_{TT} (typ.) (V)	C_{LOAD} (pF)
$V_{REF} - 0.05$	$V_{REF} + 0.05$	0.8	0.8	1.2	10

Note: *Measuring point = V_{trip} . See Table 2-15 on page 2-19 for a complete table of trip points.

Timing Characteristics

Table 2-50 • 3.3 V GTL

**Commercial-Case Conditions: $T_J = 70^\circ\text{C}$, Worst-Case $V_{CC} = 1.425\text{ V}$,
 Worst-Case $V_{CCI} = 3.0\text{ V}$ $V_{REF} = 0.8\text{ V}$**

Speed Grade	t_{DOUT}	t_{DP}	t_{DIN}	t_{PY}	t_{EOUT}	t_{ZL}	t_{ZH}	t_{LZ}	t_{HZ}	t_{ZLS}	t_{ZHS}	Units
Std.	0.60	2.08	0.04	2.93	0.43	2.04	2.08			4.27	4.31	ns
-1	0.51	1.77	0.04	2.50	0.36	1.73	1.77			3.63	3.67	ns
-2	0.45	1.55	0.03	2.19	0.32	1.52	1.55			3.19	3.22	ns

Note: For specific junction temperature and voltage supply levels, refer to [Table 2-6 on page 2-6](#) for derating values.

2.5 V GTL

Gunning Transceiver Logic is a high-speed bus standard (JESD8-3). It provides a differential amplifier input buffer and an open-drain output buffer. The VCCI pin should be connected to 2.5 V.

Table 2-51 • Minimum and Maximum DC Input and Output Levels

2.5 GTL Drive Strength	VIL		VIH		VOL	VOH	IOL	IOH	IOSL	IOSH	IIL	IIH
	Min., V	Max. V	Min. V	Max. V	Max. V	Min. V	mA	mA	Max. mA ¹	Max. mA ¹	μA ²	μA ²
20 mA ³	-0.3	VREF - 0.05	VREF + 0.05	3.6	0.4	-	20	20	124	169	10	10

Notes:

1. Currents are measured at high temperature (100°C junction temperature) and maximum voltage.
2. Currents are measured at 85°C junction temperature.
3. Output drive strength is below JEDEC specification.

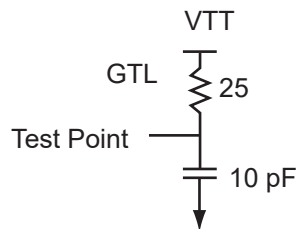

Figure 2-13 • AC Loading

Table 2-52 • AC Waveforms, Measuring Points, and Capacitive Loads

Input Low (V)	Input High (V)	Measuring Point* (V)	VREF (typ.) (V)	VTT (typ.) (V)	C _{LOAD} (pF)
VREF - 0.05	VREF + 0.05	0.8	0.8	1.2	10

Note: *Measuring point = Vtrip. See Table 2-15 on page 2-19 for a complete table of trip points.

Timing Characteristics

Table 2-53 • 2.5 V GTL

Commercial-Case Conditions: T_J = 70°C, Worst-Case VCC = 1.425 V,
Worst-Case VCCI = 3.0 V VREF = 0.8 V

Speed Grade	t _{DOUT}	t _{DP}	t _{DIN}	t _{PY}	t _{EOUT}	t _{ZL}	t _{ZH}	t _{LZ}	t _{HZ}	t _{ZLS}	t _{ZHS}	Units
Std.	0.60	2.13	0.04	2.46	0.43	2.16	2.13			4.40	4.36	ns
-1	0.51	1.81	0.04	2.09	0.36	1.84	1.81			3.74	3.71	ns
-2	0.45	1.59	0.03	1.83	0.32	1.61	1.59			3.28	3.26	ns

Note: For specific junction temperature and voltage supply levels, refer to Table 2-6 on page 2-6 for derating values.

3.3 V GTL+

Gunning Transceiver Logic Plus is a high-speed bus standard (JESD8-3). It provides a differential amplifier input buffer and an open-drain output buffer. The VCCI pin should be connected to 3.3 V.

Table 2-54 • Minimum and Maximum DC Input and Output Levels

3.3 V GTL+	VIL		VIH		VOL	VOH	IOL	IOH	IOSL	IOSH	IIL	IIH
	Min. V	Max. V	Min. V	Max. V	Max. V	Min. V	mA	mA	Max. mA ¹	Max. mA ¹	μA ²	μA ²
35 mA	-0.3	VREF - 0.1	VREF + 0.1	3.6	0.6	-	35	35	181	268	10	10

Notes:

1. Currents are measured at high temperature (100°C junction temperature) and maximum voltage.
2. Currents are measured at 85°C junction temperature.

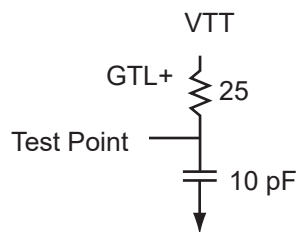

Figure 2-14 • AC Loading

Table 2-55 • AC Waveforms, Measuring Points, and Capacitive Loads

Input Low (V)	Input High (V)	Measuring Point* (V)	VREF (typ.) (V)	VTT (typ.) (V)	C _{LOAD} (pF)
VREF - 0.1	VREF + 0.1	1.0	1.0	1.5	10

Note: *Measuring point = Vtrip. See Table 2-15 on page 2-19 for a complete table of trip points.

Timing Characteristics

Table 2-56 • 3.3 V GTL+

**Commercial-Case Conditions: T_J = 70°C, Worst-Case VCC = 1.425 V,
Worst-Case VCCI = 3.0 V, VREF = 1.0 V**

Speed Grade	t _{DOUT}	t _{DP}	t _{DIN}	t _{PY}	t _{EOUT}	t _{ZL}	t _{ZH}	t _{LZ}	t _{HZ}	t _{ZLS}	t _{ZHS}	Units
Std.	0.60	2.06	0.04	1.59	0.43	2.09	2.06			4.33	4.29	ns
-1	0.51	1.75	0.04	1.35	0.36	1.78	1.75			3.68	3.65	ns
-2	0.45	1.53	0.03	1.19	0.32	1.56	1.53			3.23	3.20	ns

Note: For specific junction temperature and voltage supply levels, refer to Table 2-6 on page 2-6 for derating values.

2.5 V GTL+

Gunning Transceiver Logic Plus is a high-speed bus standard (JESD8-3). It provides a differential amplifier input buffer and an open-drain output buffer. The VCCI pin should be connected to 2.5 V.

Table 2-57 • Minimum and Maximum DC Input and Output Levels

2.5 V GTL+	VIL		VIH		VOL	VOH	IOL	IOH	IOSL	IOSH	IIL	IIH
Drive Strength	Min. V	Max. V	Min. V	Max. V	Max. V	Min. V	mA	mA	Max. mA ¹	Max. mA ¹	μA ²	μA ²
33 mA	-0.3	VREF - 0.1	VREF + 0.1	3.6	0.6	-	33	33	124	169	10	10

Notes:

1. Currents are measured at high temperature (100°C junction temperature) and maximum voltage.
2. Currents are measured at 85°C junction temperature.

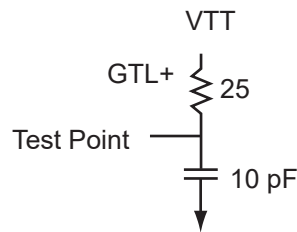

Figure 2-15 • AC Loading

Table 2-58 • AC Waveforms, Measuring Points, and Capacitive Loads

Input Low (V)	Input High (V)	Measuring Point* (V)	VREF (typ.) (V)	VTT (typ.) (V)	C _{LOAD} (pF)
VREF - 0.1	VREF + 0.1	1.0	1.0	1.5	10

Note: *Measuring point = Vtrip. See Table 2-15 on page 2-19 for a complete table of trip points.

Timing Characteristics

Table 2-59 • 2.5 V GTL+

Commercial-Case Conditions: T_J = 70°C, Worst-Case VCC = 1.425 V, Worst-Case VCCI = 2.3 V, VREF = 1.0 V

Speed Grade	t _{DOUT}	t _{DP}	t _{DIN}	t _{PY}	t _{EOUT}	t _{ZL}	t _{ZH}	t _{LZ}	t _{HZ}	t _{ZLS}	t _{ZHS}	Units
Std.	0.60	2.21	0.04	1.51	0.43	2.25	2.10			4.48	4.34	ns
-1	0.51	1.88	0.04	1.29	0.36	1.91	1.79			3.81	3.69	ns
-2	0.45	1.65	0.03	1.13	0.32	1.68	1.57			3.35	3.24	ns

Note: For specific junction temperature and voltage supply levels, refer to Table 2-6 on page 2-6 for derating values.

HSTL Class I

High-Speed Transceiver Logic is a general-purpose high-speed 1.5 V bus standard (EIA/JESD8-6). ProASIC3E devices support Class I. This provides a differential amplifier input buffer and a push-pull output buffer.

Table 2-60 • Minimum and Maximum DC Input and Output Levels

HSTL Class I	VIL		VIH		VOL	VOH	IOL	IOH	IOSL	IOSH	IIL	IIH
	Min. V	Max. V	Min. V	Max. V	Max. V	Min. V	mA	mA	Max. mA ¹	Max. mA ¹	μA ²	μA ²
8 mA	-0.3	VREF - 0.1	VREF + 0.1	3.6	0.4	VCCI - 0.4	8	8	39	32	10	10

Notes:

1. Currents are measured at high temperature (100°C junction temperature) and maximum voltage.
2. Currents are measured at 85°C junction temperature.

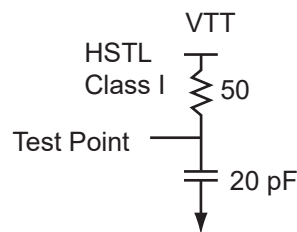

Figure 2-16 • AC Loading

Table 2-61 • AC Waveforms, Measuring Points, and Capacitive Loads

Input Low (V)	Input High (V)	Measuring Point* (V)	VREF (typ.) (V)	VTT (typ.) (V)	C _{LOAD} (pF)
VREF - 0.1	VREF + 0.1	0.75	0.75	0.75	20

Note: *Measuring point = Vtrip. See Table 2-15 on page 2-19 for a complete table of trip points.

Timing Characteristics

Table 2-62 • HSTL Class I

Commercial-Case Conditions: T_J = 70°C, Worst-Case VCC = 1.425 V, Worst-Case VCCI = .4 V, VREF = 0.75 V

Speed Grade	t _{DOUT}	t _{DP}	t _{DIN}	t _{PY}	t _{EOUT}	t _{ZL}	t _{ZH}	t _{LZ}	t _{HZ}	t _{ZLS}	t _{ZHS}	Units
Std.	0.66	3.18	0.04	2.12	0.43	3.24	3.14			5.47	5.38	ns
-1	0.56	2.70	0.04	1.81	0.36	2.75	2.67			4.66	4.58	ns
-2	0.49	2.37	0.03	1.59	0.32	2.42	2.35			4.09	4.02	ns

Note: For specific junction temperature and voltage supply levels, refer to Table 2-6 on page 2-6 for derating values.

HSTL Class II

High-Speed Transceiver Logic is a general-purpose high-speed 1.5 V bus standard (EIA/JESD8-6). ProASIC3E devices support Class II. This provides a differential amplifier input buffer and a push-pull output buffer.

Table 2-63 • Minimum and Maximum DC Input and Output Levels

HSTL Class II	VIL		VIH		VOL	VOH	IOL	IOH	IOSL	IOSH	IIL	IIH
Drive Strength	Min. V	Max. V	Min. V	Max. V	Max., V	Min. V	mA	mA	Max. mA ¹	Max. mA ¹	μA ²	μA ²
15 mA ³	-0.3	VREF - 0.1	VREF + 0.1	3.6	0.4	VCCI - 0.4	15	15	55	66	10	10

Notes:

1. Currents are measured at high temperature (100°C junction temperature) and maximum voltage.
2. Currents are measured at 85°C junction temperature.
3. Output drive strength is below JEDEC specification.

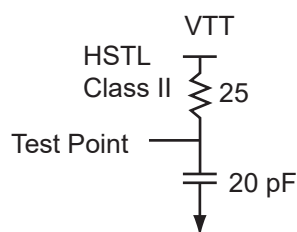

Figure 2-17 • AC Loading

Table 2-64 • AC Waveforms, Measuring Points, and Capacitive Loads

Input Low (V)	Input High (V)	Measuring Point* (V)	VREF (typ.) (V)	VTT (typ.) (V)	C _{LOAD} (pF)
VREF - 0.1	VREF + 0.1	0.75	0.75	0.75	20

Note: *Measuring point = Vtrip. See Table 2-15 on page 2-19 for a complete table of trip points.

Timing Characteristics

Table 2-65 • HSTL Class II

Commercial-Case Conditions: T_J = 70°C, Worst-Case VCC = 1.425 V, Worst-Case VCCI = 1.4 V, VREF = 0.75 V

Speed Grade	t _{DOUT}	t _{DP}	t _{DIN}	t _{PY}	t _{EOUT}	t _{ZL}	t _{ZH}	t _{LZ}	t _{HZ}	t _{ZLS}	t _{ZHS}	Units
Std.	0.66	3.02	0.04	2.12	0.43	3.08	2.71			5.32	4.95	ns
-1	0.56	2.57	0.04	1.81	0.36	2.62	2.31			4.52	4.21	ns
-2	0.49	2.26	0.03	1.59	0.32	2.30	2.03			3.97	3.70	ns

Note: For specific junction temperature and voltage supply levels, refer to Table 2-6 on page 2-6 for derating values.

SSTL2 Class I

Stub-Speed Terminated Logic for 2.5 V memory bus standard (JESD8-9). ProASIC3E devices support Class I. This provides a differential amplifier input buffer and a push-pull output buffer.

Table 2-66 • Minimum and Maximum DC Input and Output Levels

SSTL2 Class I	VIL		VIH		VOL	VOH	IOL	IOH	IOSL	IOSH	IIL	IIH
	Min. V	Max. V	Min. V	Max. V	Max. V	Min. V	mA	mA	Max. mA ¹	Max. mA ¹	μA ²	μA ²
15 mA	-0.3	VREF - 0.2	VREF + 0.2	3.6	0.54	VCCI - 0.62	15	15	87	83	10	10

Notes:

1. Currents are measured at high temperature (100°C junction temperature) and maximum voltage.
2. Currents are measured at 85°C junction temperature.

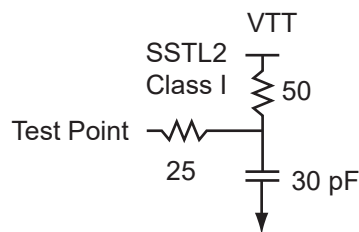

Figure 2-18 • AC Loading

Table 2-67 • AC Waveforms, Measuring Points, and Capacitive Loads

Input Low (V)	Input High (V)	Measuring Point* (V)	VREF (typ.) (V)	VTT (typ.) (V)	C _{LOAD} (pF)
VREF - 0.2	VREF + 0.2	1.25	1.25	1.25	30

Note: *Measuring point = Vtrip. See Table 2-15 on page 2-19 for a complete table of trip points.

Timing Characteristics

Table 2-68 • SSTL 2 Class I

Commercial-Case Conditions: T_J = 70°C, Worst-Case VCC = 1.425 V, Worst-Case VCCI = 2.3 V, VREF = 1.25 V

Speed Grade	t _{DOUT}	t _{DP}	t _{DIN}	t _{PY}	t _{EOUT}	t _{ZL}	t _{ZH}	t _{LZ}	t _{HZ}	t _{ZLS}	t _{ZHS}	Units
Std.	0.66	2.13	0.04	1.33	0.43	2.17	1.85			4.40	4.08	ns
-1	0.56	1.81	0.04	1.14	0.36	1.84	1.57			3.74	3.47	ns
-2	0.49	1.59	0.03	1.00	0.32	1.62	1.38			3.29	3.05	ns

Note: For specific junction temperature and voltage supply levels, refer to Table 2-6 on page 2-6 for derating values.

SSTL2 Class II

Stub-Speed Terminated Logic for 2.5 V memory bus standard (JESD8-9). ProASIC3E devices support Class II. This provides a differential amplifier input buffer and a push-pull output buffer.

Table 2-69 • Minimum and Maximum DC Input and Output Levels

SSTL2 Class II	VIL		VIH		VOL	VOH	IOL	IOH	IOSL	IOSH	IIL	IIH
	Min. V	Max. V	Min. V	Max. V	Max. V	Min. V	mA	mA	Max. mA ¹	Max. mA ¹	μA ²	μA ²
18 mA	-0.3	VREF - 0.2	VREF + 0.2	3.6	0.35	VCCI - 0.43	18	18	124	169	10	10

Notes:

1. Currents are measured at high temperature (100°C junction temperature) and maximum voltage.
2. Currents are measured at 85°C junction temperature.

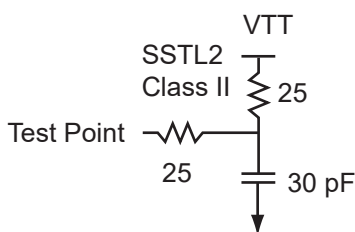

Figure 2-19 • AC Loading

Table 2-70 • AC Waveforms, Measuring Points, and Capacitive Loads

Input Low (V)	Input High (V)	Measuring Point* (V)	VREF (typ.) (V)	VTT (typ.) (V)	C _{LOAD} (pF)
VREF - 0.2	VREF + 0.2	1.25	1.25	1.25	30

Note: *Measuring point = Vtrip. See Table 2-15 on page 2-19 for a complete table of trip points.

Timing Characteristics

Table 2-71 • SSTL 2 Class II

Commercial-Case Conditions: T_J = 70°C, Worst-Case VCC = 1.425 V, Worst-Case VCCI = 2.3 V, VREF = 1.25 V

Speed Grade	t _{DOUT}	t _{DP}	t _{DIN}	t _{PY}	t _{EOUT}	t _{ZL}	t _{ZH}	t _{LZ}	t _{HZ}	t _{ZLS}	t _{ZHS}	Units
Std.	0.66	0.66	2.17	0.04	1.33	0.43	2.21	1.77			4.44	ns
-1	0.56	0.56	1.84	0.04	1.14	0.36	1.88	1.51			3.78	ns
-2	0.49	0.49	1.62	0.03	1.00	0.32	1.65	1.32			3.32	ns

Note: For specific junction temperature and voltage supply levels, refer to Table 2-6 on page 2-6 for derating values.

SSTL3 Class I

Stub-Speed Terminated Logic for 3.3 V memory bus standard (JESD8-8). ProASIC3E devices support Class I. This provides a differential amplifier input buffer and a push-pull output buffer.

Table 2-72 • Minimum and Maximum DC Input and Output Levels

SSTL3 Class I	VIL		VIH		VOL	VOH	IOL	IOH	IOSL	IOSH	IIL	IIH
	Min. V	Max. V	Min. V	Max. V	Max. V	Min. V	mA	mA	Max. mA ¹	Max. mA ¹	μA ²	μA ²
14 mA	-0.3	VREF - 0.2	VREF + 0.2	3.6	0.7	VCCI - 1.1	14	14	54	51	10	10

Notes:

1. Currents are measured at high temperature (100°C junction temperature) and maximum voltage.
2. Currents are measured at 85°C junction temperature.

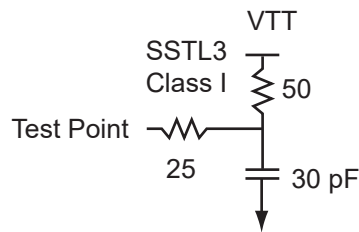

Figure 2-20 • AC Loading

Table 2-73 • AC Waveforms, Measuring Points, and Capacitive Loads

Input Low (V)	Input High (V)	Measuring Point* (V)	VREF (typ.) (V)	VTT (typ.) (V)	C _{LOAD} (pF)
VREF - 0.2	VREF + 0.2	1.5	1.5	1.485	30

Note: *Measuring point = Vtrip. See Table 2-15 on page 2-19 for a complete table of trip points.

Timing Characteristics

Table 2-74 • SSTL3 Class I

Commercial-Case Conditions: T_J = 70°C, Worst-Case VCC = 1.425 V,
Worst-Case VCCI = 3.0 V, VREF = 1.5 V

Speed Grade	t _{DOUT}	t _{DP}	t _{DIN}	t _{py}	t _{EOUT}	t _{ZL}	t _{ZH}	t _{LZ}	t _{HZ}	t _{ZLS}	t _{ZHS}	Units
Std.	0.66	2.31	0.04	1.25	0.43	2.35	1.84			4.59	4.07	ns
-1	0.56	1.96	0.04	1.06	0.36	2.00	1.56			3.90	3.46	ns
-2	0.49	1.72	0.03	0.93	0.32	1.75	1.37			3.42	3.04	ns

Note: For specific junction temperature and voltage supply levels, refer to Table 2-6 on page 2-6 for derating values.

SSTL3 Class II

Stub-Speed Terminated Logic for 3.3 V memory bus standard (JESD8-8). ProASIC3E devices support Class II. This provides a differential amplifier input buffer and a push-pull output buffer.

Table 2-75 • Minimum and Maximum DC Input and Output Levels

SSTL3 Class II	VIL		VIH		VOL	VOH	IOL	IOH	IOSL	IOSH	IIL	IIH
	Min. V	Max. V	Min. V	Max. V	Max. V	Min. V	mA	mA	Max. mA ¹	Max. mA ¹	μA ²	μA ²
21 mA	-0.3	VREF - 0.2	VREF + 0.2	3.6	0.5	VCCI - 0.9	21	21	109	103	10	10

Notes:

1. Currents are measured at high temperature (100°C junction temperature) and maximum voltage.
2. Currents are measured at 85°C junction temperature.

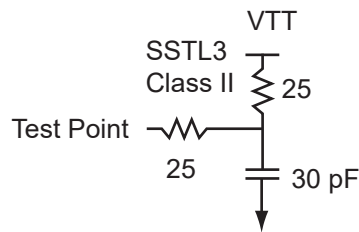

Figure 2-21 • AC Loading

Table 2-76 • AC Waveforms, Measuring Points, and Capacitive Loads

Input Low (V)	Input High (V)	Measuring Point* (V)	VREF (typ.) (V)	VTT (typ.) (V)	C _{LOAD} (pF)
VREF - 0.2	VREF + 0.2	1.5	1.5	1.485	30

Note: *Measuring point = Vtrip. See Table 2-15 on page 2-19 for a complete table of trip points.

Timing Characteristics

Table 2-77 • SSTL3 Class II

Commercial-Case Conditions: T_J = 70°C, Worst-Case VCC = 1.425 V, Worst-Case VCCI = 3.0 V, VREF = 1.5 V

Speed Grade	t _{DOUT}	t _{DP}	t _{DIN}	t _{PY}	t _{EOUT}	t _{ZL}	t _{ZH}	t _{LZ}	t _{HZ}	t _{ZLS}	t _{ZHS}	Units
Std.	0.66	2.07	0.04	1.25	0.43	2.10	1.67			4.34	3.91	ns
-1	0.56	1.76	0.04	1.06	0.36	1.79	1.42			3.69	3.32	ns
-2	0.49	1.54	0.03	0.93	0.32	1.57	1.25			3.24	2.92	ns

Note: For specific junction temperature and voltage supply levels, refer to Table 2-6 on page 2-6 for derating values.

Differential I/O Characteristics

Physical Implementation

Configuration of the I/O modules as a differential pair is handled by the Designer software when the user instantiates a differential I/O macro in the design.

Differential I/Os can also be used in conjunction with the embedded Input Register (InReg), Output Register (OutReg), Enable Register (EnReg), and DDR. However, there is no support for bidirectional I/Os or tristates with the LVPECL standards.

LVDS

Low-Voltage Differential Signaling (ANSI/TIA/EIA-644) is a high-speed, differential I/O standard. It requires that one data bit be carried through two signal lines, so two pins are needed. It also requires external resistor termination.

The full implementation of the LVDS transmitter and receiver is shown in an example in Figure 2-22. The building blocks of the LVDS transmitter-receiver are one transmitter macro, one receiver macro, three board resistors at the transmitter end, and one resistor at the receiver end. The values for the three driver resistors are different from those used in the LVPECL implementation because the output standard specifications are different.

Along with LVDS I/O, ProASIC3E also supports Bus LVDS structure and Multipoint LVDS (M-LVDS) configuration (up to 40 nodes).

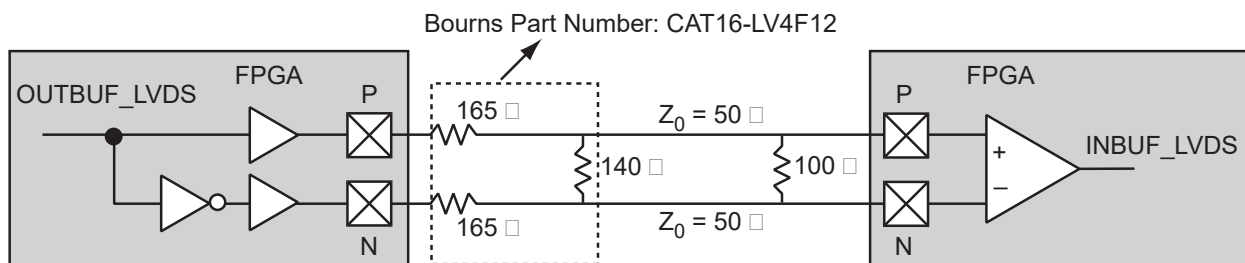

Figure 2-22 • LVDS Circuit Diagram and Board-Level Implementation

Table 2-78 • LVDS Minimum and Maximum DC Input and Output Levels

DC Parameter	Description	Min.	Typ.	Max.	Units
VCCI	Supply Voltage	2.375	2.5	2.625	V
VOL	Output Low Voltage	0.9	1.075	1.25	V
VOH	Output High Voltage	1.25	1.425	1.6	V
IOL ¹	Output Lower Current	0.65	0.91	1.16	mA
IOH ¹	Output High Current	0.65	0.91	1.16	mA
VI	Input Voltage	0		2.925	V
IIH ²	Input High Leakage Current			10	μA
IIL ²	Input Low Leakage Current			10	μA
VODIFF	Differential Output Voltage	250	350	450	mV
VOCM	Output Common Mode Voltage	1.125	1.25	1.375	V
VICM	Input Common Mode Voltage	0.05	1.25	2.35	V
VIDIFF	Input Differential Voltage ²	100	350		mV

Notes:

1. IOL/IOH defined by VODIFF/(Resistor Network).
2. Currents are measured at 85°C junction temperature.

Table 2-79 • AC Waveforms, Measuring Points, and Capacitive Loads

Input Low (V)	Input High (V)	Measuring Point* (V)	VREF (typ.) (V)
1.075	1.325	Cross point	–

Note: *Measuring point = Vtrip. See Table 2-15 on page 2-19 for a complete table of trip points.

Timing Characteristics

Table 2-80 • LVDS

Commercial-Case Conditions: $T_J = 70^\circ\text{C}$, Worst-Case $V_{CC} = 1.425\text{ V}$, Worst-Case $V_{CCI} = 2.3\text{ V}$

Speed Grade	t_{DOUT}	t_{DP}	t_{DIN}	t_{pY}	Units
Std.	0.66	1.87	0.04	1.82	ns
-1	0.56	1.59	0.04	1.55	ns
-2	0.49	1.40	0.03	1.36	ns

Note: For specific junction temperature and voltage supply levels, refer to [Table 2-6](#) on [page 2-6](#) for derating values.

B-LVDS/M-LVDS

Bus LVDS (B-LVDS) and Multipoint LVDS (M-LVDS) specifications extend the existing LVDS standard to high-performance multipoint bus applications. Multidrop and multipoint bus configurations may contain any combination of drivers, receivers, and transceivers. Microsemi LVDS drivers provide the higher drive current required by B-LVDS and M-LVDS to accommodate the loading. The drivers require series terminations for better signal quality and to control voltage swing. Termination is also required at both ends of the bus since the driver can be located anywhere on the bus. These configurations can be implemented using the TRIBUF_LVDS and BIBUF_LVDS macros along with appropriate terminations. Multipoint designs using Microsemi LVDS macros can achieve up to 200 MHz with a maximum of 20 loads. A sample application is given in [Figure 2-23](#). The input and output buffer delays are available in the LVDS section in [Table 2-80](#).

Example: For a bus consisting of 20 equidistant loads, the following terminations provide the required differential voltage, in worst-case Industrial operating conditions, at the farthest receiver: $R_S = 60\ \Omega$ and $R_T = 70\ \Omega$, given $Z_0 = 50\ \Omega$ (2") and $Z_{stub} = 50\ \Omega$ (~1.5").

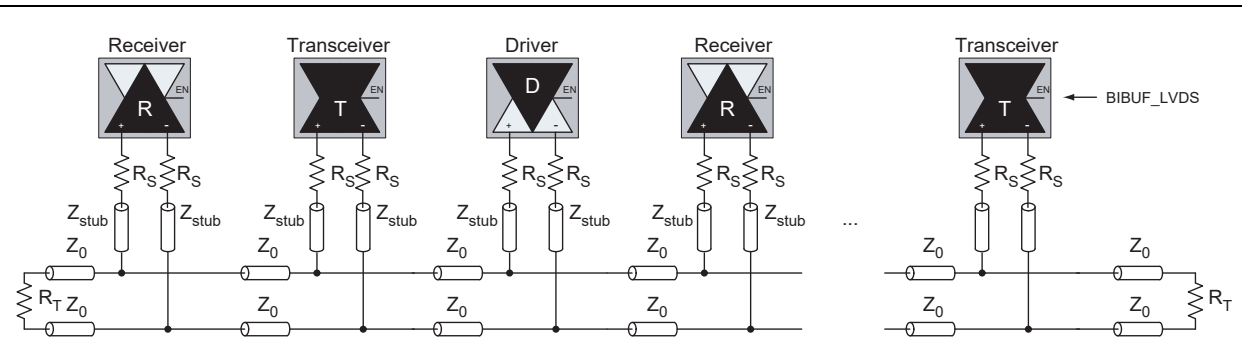

Figure 2-23 • B-LVDS/M-LVDS Multipoint Application Using LVDS I/O Buffers

LVPECL

Low-Voltage Positive Emitter-Coupled Logic (LVPECL) is another differential I/O standard. It requires that one data bit be carried through two signal lines. Like LVDS, two pins are needed. It also requires external resistor termination.

The full implementation of the LVDS transmitter and receiver is shown in an example in Figure 2-24. The building blocks of the LVPECL transmitter-receiver are one transmitter macro, one receiver macro, three board resistors at the transmitter end, and one resistor at the receiver end. The values for the three driver resistors are different from those used in the LVDS implementation because the output standard specifications are different.

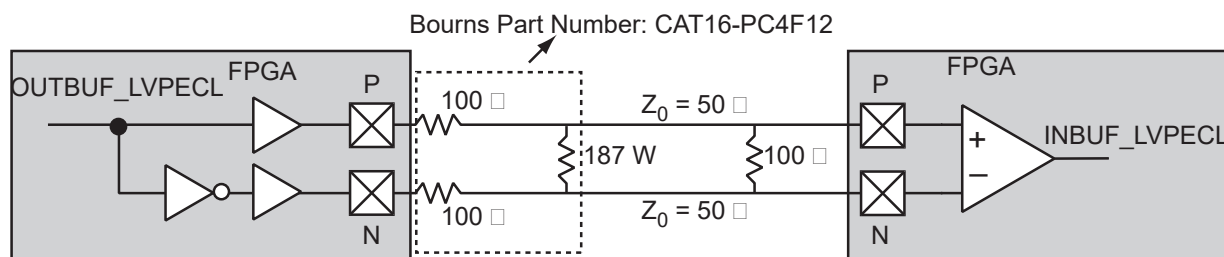

Figure 2-24 • LVPECL Circuit Diagram and Board-Level Implementation

Table 2-81 • Minimum and Maximum DC Input and Output Levels

DC Parameter	Description	Min.	Max.	Min.	Max.	Min.	Max.	Units
VCCI	Supply Voltage	3.0		3.3		3.6		V
VOL	Output Low Voltage	0.96	1.27	1.06	1.43	1.30	1.57	V
VOH	Output High Voltage	1.8	2.11	1.92	2.28	2.13	2.41	V
VIL, VIH	Input Low, Input High Voltages	0	3.6	0	3.6	0	3.6	V
VODIFF	Differential Output Voltage	0.625	0.97	0.625	0.97	0.625	0.97	V
VOCM	Output Common-Mode Voltage	1.762	1.98	1.762	1.98	1.762	1.98	V
VICM	Input Common-Mode Voltage	1.01	2.57	1.01	2.57	1.01	2.57	V
VIDIFF	Input Differential Voltage	300		300		300		mV

Table 2-82 • AC Waveforms, Measuring Points, and Capacitive Loads

Input Low (V)	Input High (V)	Measuring Point* (V)	VREF (typ.) (V)
1.64	1.94	Cross point	–

Note: *Measuring point = V_{trip} . See Table 2-15 on page 2-19 for a complete table of trip points.

Timing Characteristics

Table 2-83 • LVPECL

Commercial-Case Conditions: $T_J = 70^\circ\text{C}$, Worst-Case $V_{CC} = 1.425\text{ V}$, Worst-Case $V_{CCI} = 3.0\text{ V}$

Speed Grade	t_{DOUT}	t_{DP}	t_{DIN}	t_{pY}	Units
Std.	0.66	1.83	0.04	1.63	ns
-1	0.56	1.55	0.04	1.39	ns
-2	0.49	1.36	0.03	1.22	ns

Note: For specific junction temperature and voltage supply levels, refer to Table 2-6 on page 2-6 for derating values.

I/O Register Specifications

Fully Registered I/O Buffers with Synchronous Enable and Asynchronous Preset

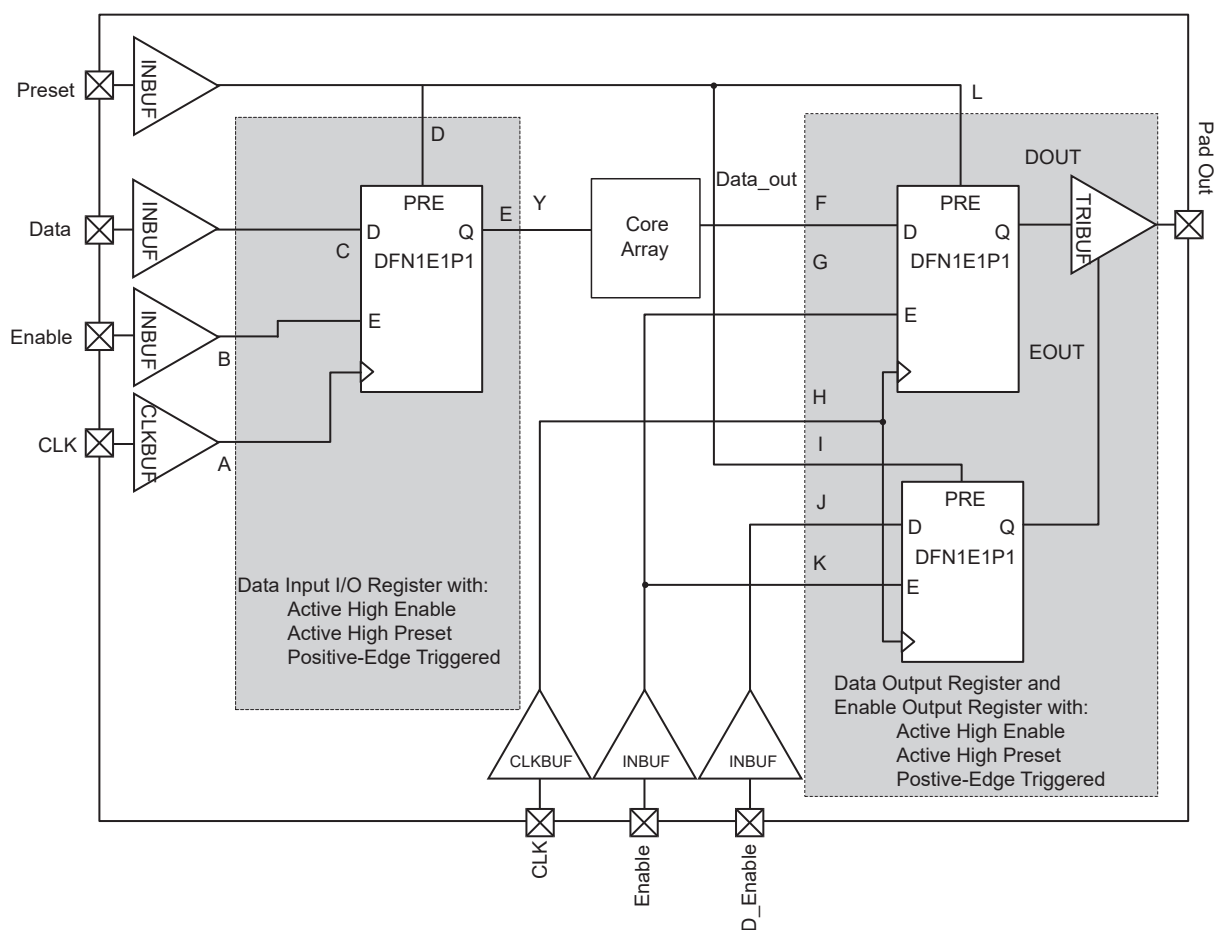

Figure 2-25 • Timing Model of Registered I/O Buffers with Synchronous Enable and Asynchronous Preset

Table 2-84 • Parameter Definition and Measuring Nodes

Parameter Name	Parameter Definition	Measuring Nodes (from, to)*
t_{OCLKQ}	Clock-to-Q of the Output Data Register	H, DOUT
t_{OSUD}	Data Setup Time for the Output Data Register	F, H
t_{OHD}	Data Hold Time for the Output Data Register	F, H
t_{OSUE}	Enable Setup Time for the Output Data Register	G, H
t_{OHE}	Enable Hold Time for the Output Data Register	G, H
t_{OPRE2Q}	Asynchronous Preset-to-Q of the Output Data Register	L, DOUT
$t_{OREMPRE}$	Asynchronous Preset Removal Time for the Output Data Register	L, H
$t_{ORECPRE}$	Asynchronous Preset Recovery Time for the Output Data Register	L, H
t_{OECLKQ}	Clock-to-Q of the Output Enable Register	H, EOUT
t_{OESUD}	Data Setup Time for the Output Enable Register	J, H
t_{OEHD}	Data Hold Time for the Output Enable Register	J, H
t_{OESUE}	Enable Setup Time for the Output Enable Register	K, H
t_{OEHE}	Enable Hold Time for the Output Enable Register	K, H
$t_{OEPRE2Q}$	Asynchronous Preset-to-Q of the Output Enable Register	I, EOUT
$t_{OEREMPRE}$	Asynchronous Preset Removal Time for the Output Enable Register	I, H
$t_{OERECPRE}$	Asynchronous Preset Recovery Time for the Output Enable Register	I, H
t_{ICLKQ}	Clock-to-Q of the Input Data Register	A, E
t_{ISUD}	Data Setup Time for the Input Data Register	C, A
t_{IHD}	Data Hold Time for the Input Data Register	C, A
t_{ISUE}	Enable Setup Time for the Input Data Register	B, A
t_{IHE}	Enable Hold Time for the Input Data Register	B, A
t_{IPRE2Q}	Asynchronous Preset-to-Q of the Input Data Register	D, E
$t_{IREMPRE}$	Asynchronous Preset Removal Time for the Input Data Register	D, A
$t_{IRECPRE}$	Asynchronous Preset Recovery Time for the Input Data Register	D, A

Note: *See Figure 2-25 on page 2-55 for more information.

Fully Registered I/O Buffers with Synchronous Enable and Asynchronous Clear

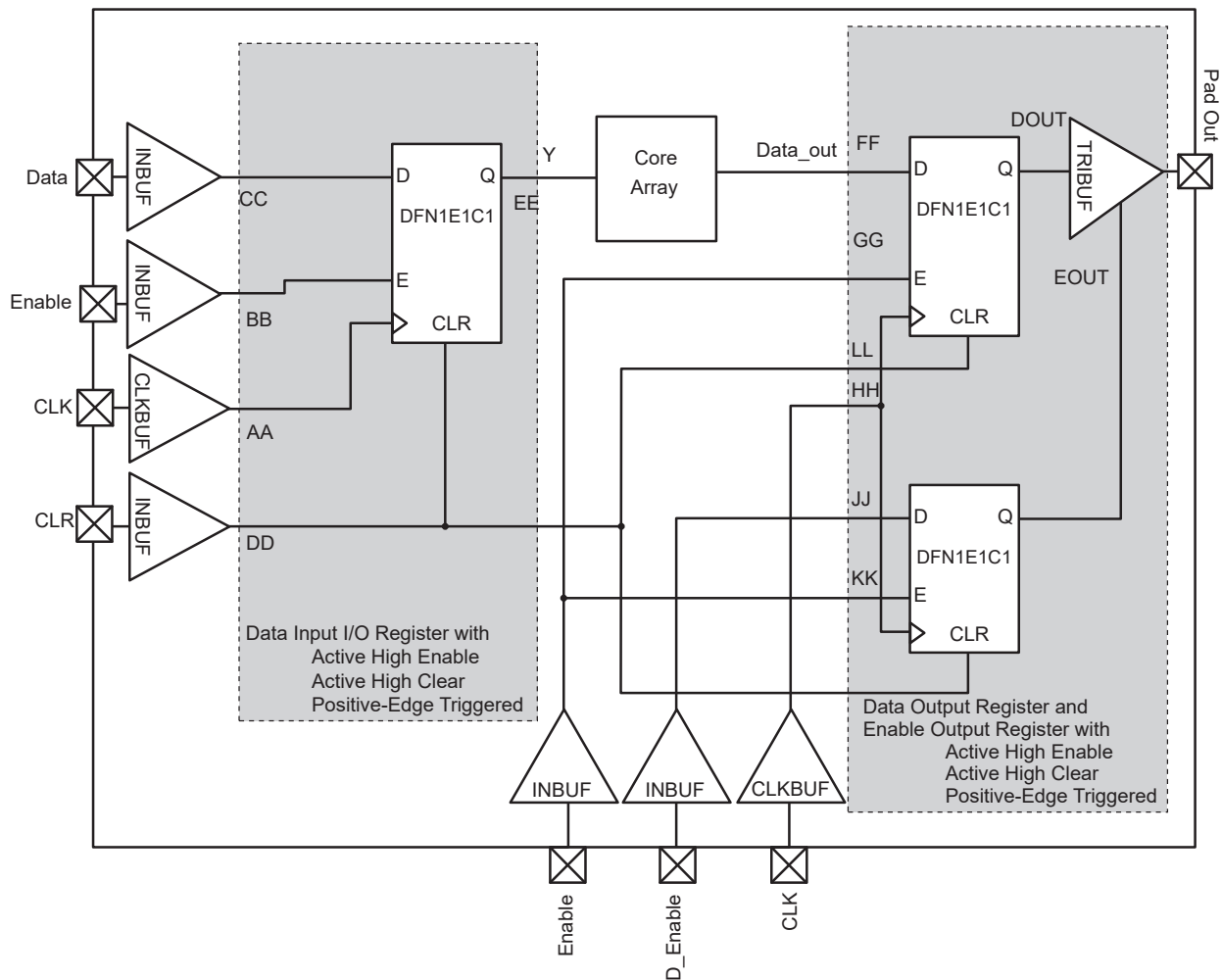

Figure 2-26 • Timing Model of the Registered I/O Buffers with Synchronous Enable and Asynchronous Clear

Table 2-85 • Parameter Definition and Measuring Nodes

Parameter Name	Parameter Definition	Measuring Nodes (from, to)*
t_{OCLKQ}	Clock-to-Q of the Output Data Register	HH, DOUT
t_{OSUD}	Data Setup Time for the Output Data Register	FF, HH
t_{OHD}	Data Hold Time for the Output Data Register	FF, HH
t_{OSUE}	Enable Setup Time for the Output Data Register	GG, HH
t_{OHE}	Enable Hold Time for the Output Data Register	GG, HH
t_{OCLR2Q}	Asynchronous Clear-to-Q of the Output Data Register	LL, DOUT
$t_{OERMCLR}$	Asynchronous Clear Removal Time for the Output Data Register	LL, HH
$t_{ORECCLR}$	Asynchronous Clear Recovery Time for the Output Data Register	LL, HH
t_{OECLKQ}	Clock-to-Q of the Output Enable Register	HH, EOUT
t_{OESUD}	Data Setup Time for the Output Enable Register	JJ, HH
t_{OEHD}	Data Hold Time for the Output Enable Register	JJ, HH
t_{OESUE}	Enable Setup Time for the Output Enable Register	KK, HH
t_{OEHE}	Enable Hold Time for the Output Enable Register	KK, HH
$t_{OECLR2Q}$	Asynchronous Clear-to-Q of the Output Enable Register	II, EOUT
$t_{OERMCLR}$	Asynchronous Clear Removal Time for the Output Enable Register	II, HH
$t_{OERCCLR}$	Asynchronous Clear Recovery Time for the Output Enable Register	II, HH
t_{ICLKQ}	Clock-to-Q of the Input Data Register	AA, EE
t_{ISUD}	Data Setup Time for the Input Data Register	CC, AA
t_{IHD}	Data Hold Time for the Input Data Register	CC, AA
t_{ISUE}	Enable Setup Time for the Input Data Register	BB, AA
t_{IHE}	Enable Hold Time for the Input Data Register	BB, AA
t_{ICLR2Q}	Asynchronous Clear-to-Q of the Input Data Register	DD, EE
$t_{IERMCLR}$	Asynchronous Clear Removal Time for the Input Data Register	DD, AA
$t_{IRECCLR}$	Asynchronous Clear Recovery Time for the Input Data Register	DD, AA

Note: *See Figure 2-26 on page 2-57 for more information.

Input Register

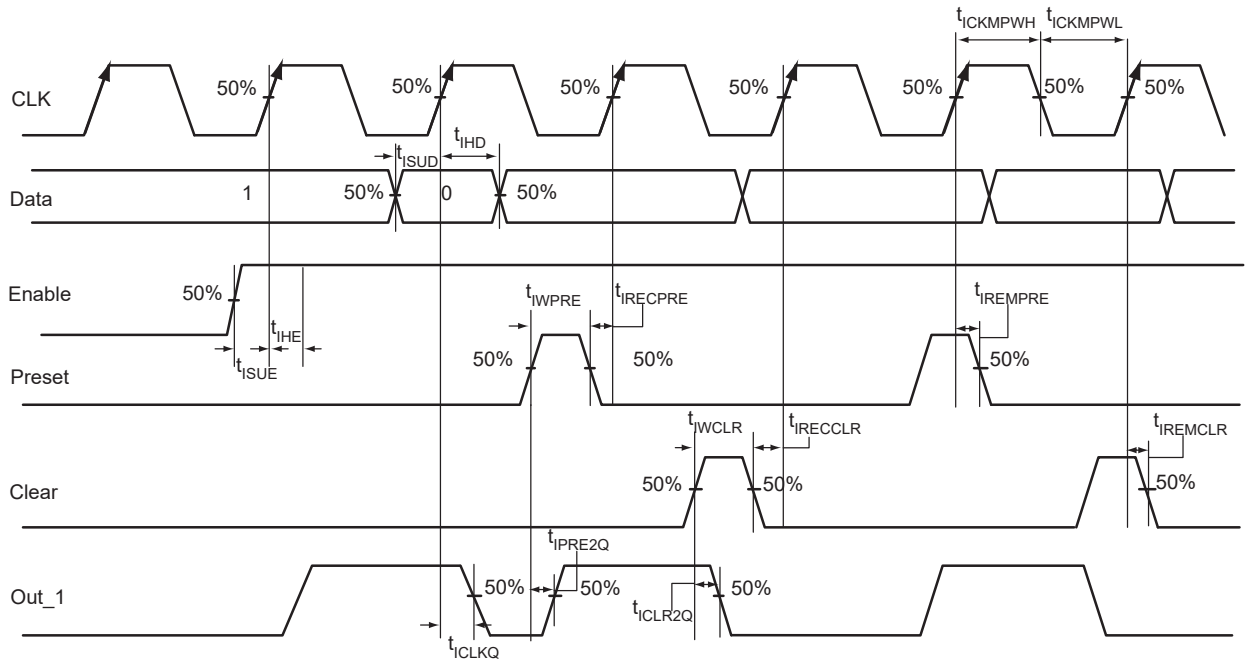

Figure 2-27 • Input Register Timing Diagram

Timing Characteristics

Table 2-86 • Input Data Register Propagation Delays
Commercial-Case Conditions: $T_J = 70^\circ\text{C}$, Worst-Case $V_{CC} = 1.425\text{ V}$

Parameter	Description	-2	-1	Std.	Units
t_{ICLKQ}	Clock-to-Q of the Input Data Register	0.24	0.27	0.32	ns
t_{ISUD}	Data Setup Time for the Input Data Register	0.26	0.30	0.35	ns
t_{IHD}	Data Hold Time for the Input Data Register	0.00	0.00	0.00	ns
t_{ISUE}	Enable Setup Time for the Input Data Register	0.37	0.42	0.50	ns
t_{IHE}	Enable Hold Time for the Input Data Register	0.00	0.00	0.00	ns
t_{ICLR2Q}	Asynchronous Clear-to-Q of the Input Data Register	0.45	0.52	0.61	ns
t_{IPRE2Q}	Asynchronous Preset-to-Q of the Input Data Register	0.45	0.52	0.61	ns
$t_{IREMCLR}$	Asynchronous Clear Removal Time for the Input Data Register	0.00	0.00	0.00	ns
$t_{IRECCLR}$	Asynchronous Clear Recovery Time for the Input Data Register	0.22	0.25	0.30	ns
$t_{IREMPRE}$	Asynchronous Preset Removal Time for the Input Data Register	0.00	0.00	0.00	ns
$t_{IRECPRE}$	Asynchronous Preset Recovery Time for the Input Data Register	0.22	0.25	0.30	ns
t_{IWCLR}	Asynchronous Clear Minimum Pulse Width for the Input Data Register	0.22	0.25	0.30	ns
t_{IWPRE}	Asynchronous Preset Minimum Pulse Width for the Input Data Register	0.22	0.25	0.30	ns
$t_{ICKMPWH}$	Clock Minimum Pulse Width High for the Input Data Register	0.36	0.41	0.48	ns
$t_{ICKMPWL}$	Clock Minimum Pulse Width Low for the Input Data Register	0.32	0.37	0.43	ns

Note: For specific junction temperature and voltage supply levels, refer to Table 2-6 on page 2-6 for derating values.

Output Register

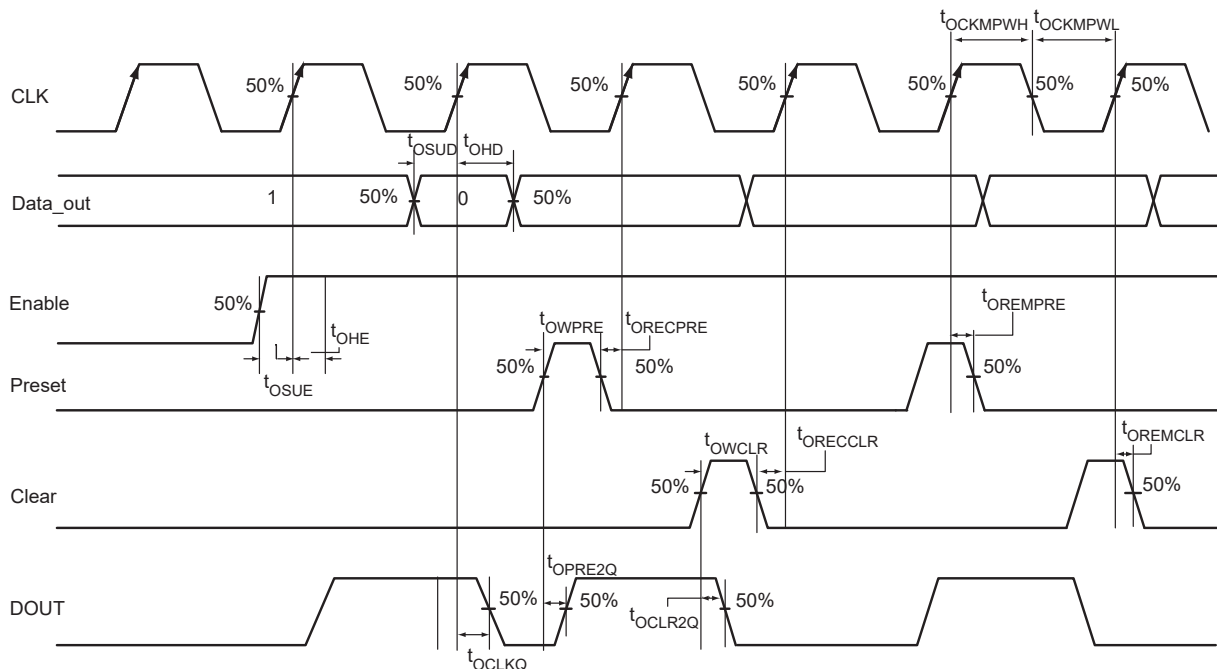

Figure 2-28 • Output Register Timing Diagram

Timing Characteristics

Table 2-87 • Output Data Register Propagation Delays

Commercial-Case Conditions: $T_j = 70^\circ\text{C}$, Worst-Case $V_{CC} = 1.425\text{ V}$

Parameter	Description	-2	-1	Std.	Units
t_{OCLKQ}	Clock-to-Q of the Output Data Register	0.59	0.67	0.79	ns
t_{OSUD}	Data Setup Time for the Output Data Register	0.31	0.36	0.42	ns
t_{OHD}	Data Hold Time for the Output Data Register	0.00	0.00	0.00	ns
t_{OSUE}	Enable Setup Time for the Output Data Register	0.44	0.50	0.59	ns
t_{OHE}	Enable Hold Time for the Output Data Register	0.00	0.00	0.00	ns
t_{OCLR2Q}	Asynchronous Clear-to-Q of the Output Data Register	0.80	0.91	1.07	ns
t_{OPRE2Q}	Asynchronous Preset-to-Q of the Output Data Register	0.80	0.91	1.07	ns
$t_{OREMCLR}$	Asynchronous Clear Removal Time for the Output Data Register	0.00	0.00	0.00	ns
$t_{ORECCLR}$	Asynchronous Clear Recovery Time for the Output Data Register	0.22	0.25	0.30	ns
$t_{OREMPRE}$	Asynchronous Preset Removal Time for the Output Data Register	0.00	0.00	0.00	ns
$t_{ORECPRE}$	Asynchronous Preset Recovery Time for the Output Data Register	0.22	0.25	0.30	ns
t_{OWCLR}	Asynchronous Clear Minimum Pulse Width for the Output Data Register	0.22	0.25	0.30	ns
t_{OWPRE}	Asynchronous Preset Minimum Pulse Width for the Output Data Register	0.22	0.25	0.30	ns
$t_{OCKMPWH}$	Clock Minimum Pulse Width High for the Output Data Register	0.36	0.41	0.48	ns
$t_{OCKMPWL}$	Clock Minimum Pulse Width Low for the Output Data Register	0.32	0.37	0.43	ns

Note: For specific junction temperature and voltage supply levels, refer to Table 2-6 on page 2-6 for derating values.

Output Enable Register

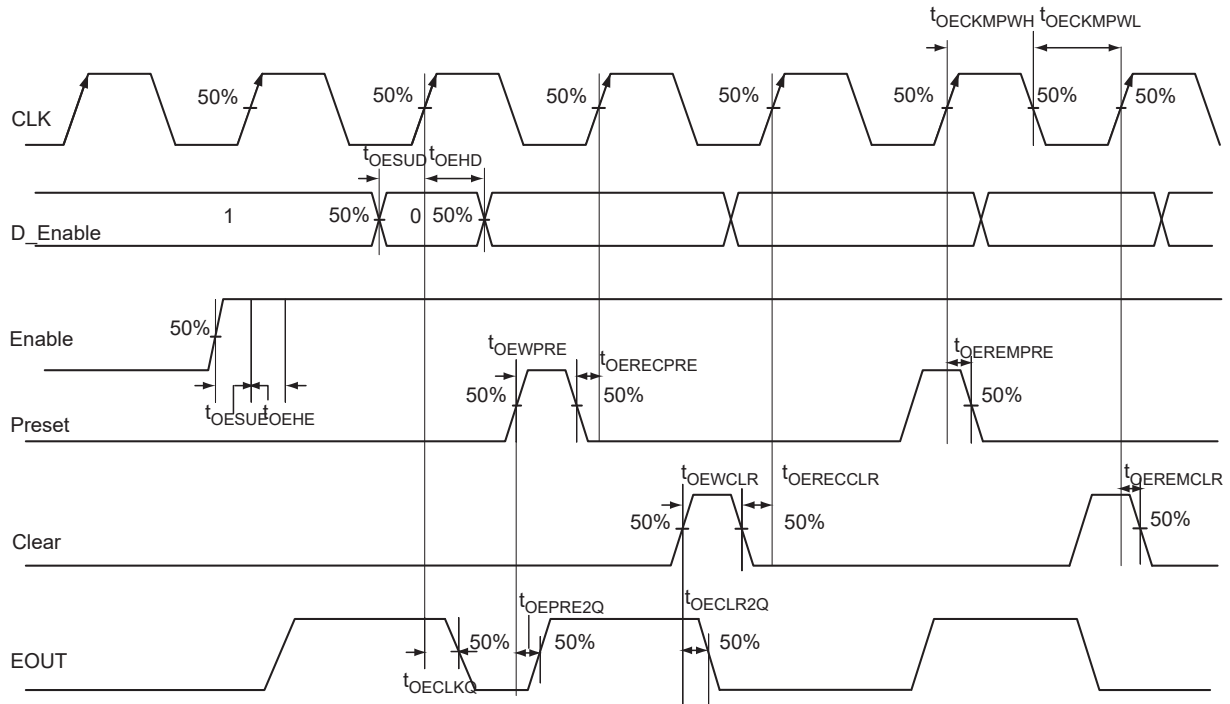

Figure 2-29 • Output Enable Register Timing Diagram

Timing Characteristics

Table 2-88 • Output Enable Register Propagation Delays
Commercial-Case Conditions: $T_j = 70^\circ\text{C}$, Worst-Case $V_{CC} = 1.425\text{ V}$

Parameter	Description	-2	-1	Std.	Units
t_{OECLKQ}	Clock-to-Q of the Output Enable Register	0.59	0.67	0.79	ns
t_{OESUD}	Data Setup Time for the Output Enable Register	0.31	0.36	0.42	ns
t_{OEHD}	Data Hold Time for the Output Enable Register	0.00	0.00	0.00	ns
t_{OESUE}	Enable Setup Time for the Output Enable Register	0.44	0.50	0.58	ns
t_{OEHE}	Enable Hold Time for the Output Enable Register	0.00	0.00	0.00	ns
$t_{OECLR2Q}$	Asynchronous Clear-to-Q of the Output Enable Register	0.67	0.76	0.89	ns
$t_{OEPRE2Q}$	Asynchronous Preset-to-Q of the Output Enable Register	0.67	0.76	0.89	ns
$t_{OEREMCLR}$	Asynchronous Clear Removal Time for the Output Enable Register	0.00	0.00	0.00	ns
$t_{OERECCLR}$	Asynchronous Clear Recovery Time for the Output Enable Register	0.22	0.25	0.30	ns
$t_{OEREMPRE}$	Asynchronous Preset Removal Time for the Output Enable Register	0.00	0.00	0.00	ns
$t_{OERECPRE}$	Asynchronous Preset Recovery Time for the Output Enable Register	0.22	0.25	0.30	ns
t_{OEWCLR}	Asynchronous Clear Minimum Pulse Width for the Output Enable Register	0.22	0.25	0.30	ns
t_{OEWPRE}	Asynchronous Preset Minimum Pulse Width for the Output Enable Register	0.22	0.25	0.30	ns
$t_{OECKMPWH}$	Clock Minimum Pulse Width High for the Output Enable Register	0.36	0.41	0.48	ns
$t_{OECKMPWL}$	Clock Minimum Pulse Width Low for the Output Enable Register	0.32	0.37	0.43	ns

Note: For specific junction temperature and voltage supply levels, refer to Table 2-6 on page 2-6 for derating values.

DDR Module Specifications

Input DDR Module

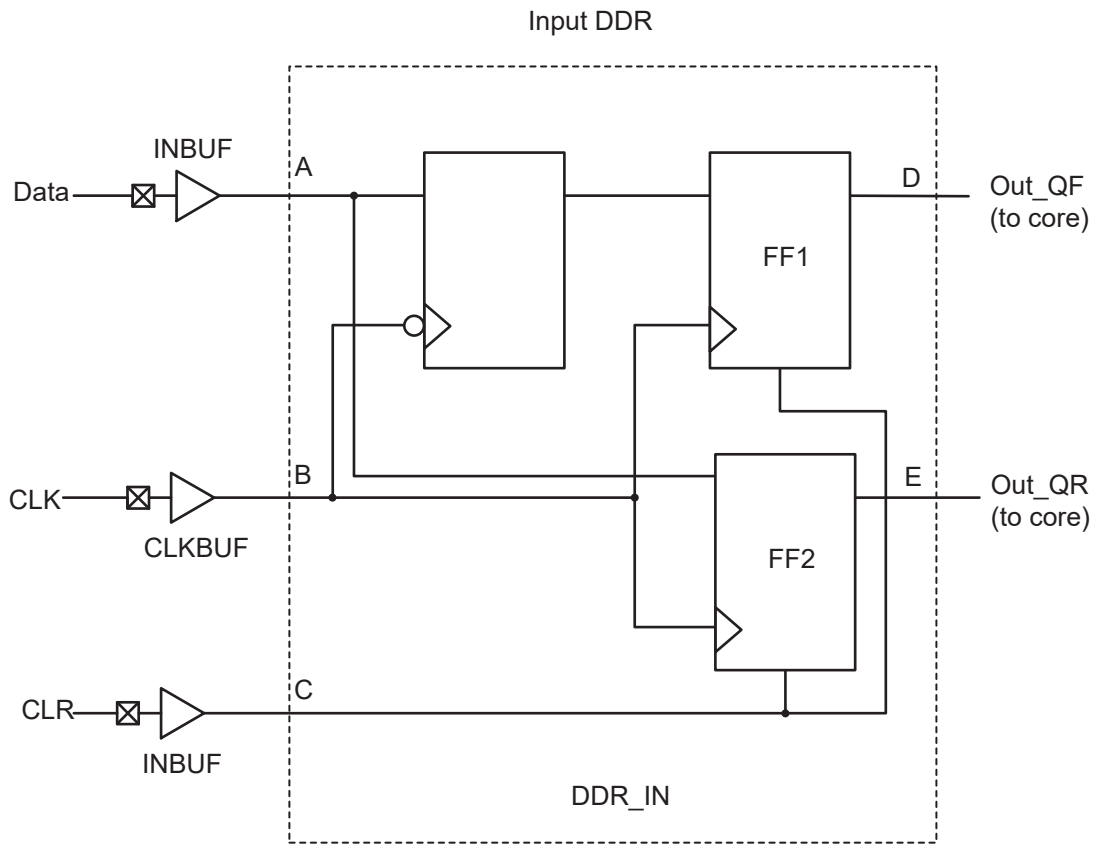

Figure 2-30 • Input DDR Timing Model

Table 2-89 • Parameter Definitions

Parameter Name	Parameter Definition	Measuring Nodes (from, to)
t_{DDRCLKQ1}	Clock-to-Out Out_QR	B, D
t_{DDRCLKQ2}	Clock-to-Out Out_QF	B, E
t_{DDRISUD}	Data Setup Time of DDR input	A, B
t_{DDRIHD}	Data Hold Time of DDR input	A, B
$t_{\text{DDRICLR2Q1}}$	Clear-to-Out Out_QR	C, D
$t_{\text{DDRICLR2Q2}}$	Clear-to-Out Out_QF	C, E
$t_{\text{DDRIREMCLR}}$	Clear Removal	C, B
$t_{\text{DDRIRECCLR}}$	Clear Recovery	C, B

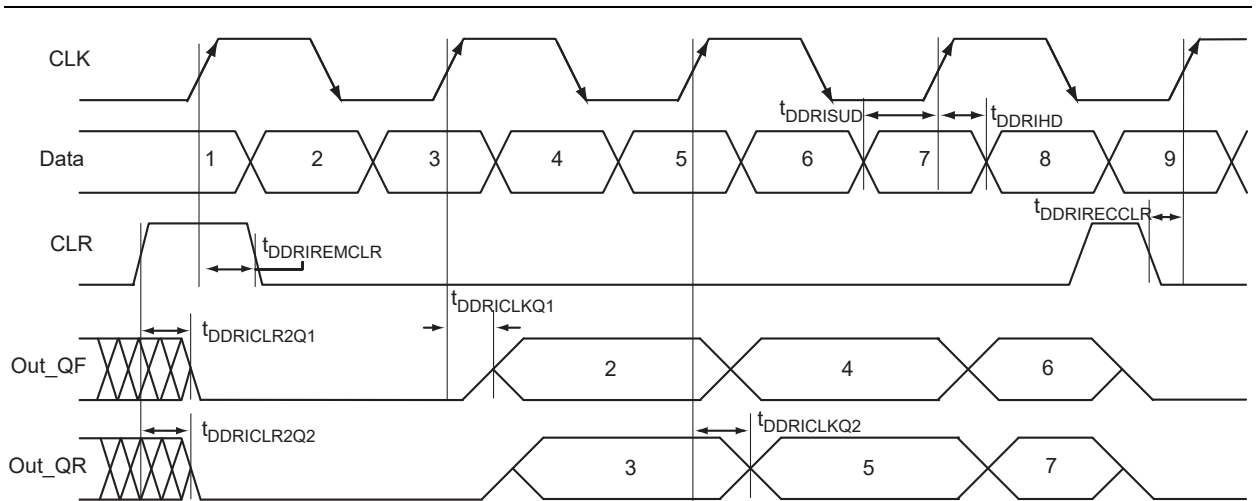

Figure 2-31 • Input DDR Timing Diagram

Timing Characteristics

Table 2-90 • Input DDR Propagation Delays

Commercial-Case Conditions: $T_J = 70^\circ\text{C}$, Worst-Case $V_{CC} = 1.425\text{ V}$

Parameter	Description	-2	-1	Std.	Units
t_{DDRICKQ1}	Clock-to-Out Out_QR for Input DDR	0.39	0.44	0.52	ns
t_{DDRICKQ2}	Clock-to-Out Out_QF for Input DDR	0.27	0.31	0.37	ns
t_{DDRISUD}	Data Setup for Input DDR	0.28	0.32	0.38	ns
t_{DDRIHD}	Data Hold for Input DDR	0.00	0.00	0.00	ns
$t_{\text{DDRICLR2Q1}}$	Asynchronous Clear to Out Out_QR for Input DDR	0.57	0.65	0.76	ns
$t_{\text{DDRICLR2Q2}}$	Asynchronous Clear-to-Out Out_QF for Input DDR	0.46	0.53	0.62	ns
$t_{\text{DDRIREMCLR}}$	Asynchronous Clear Removal Time for Input DDR	0.00	0.00	0.00	ns
$t_{\text{DDRIRECCLR}}$	Asynchronous Clear Recovery Time for Input DDR	0.22	0.25	0.30	ns
$t_{\text{DDR IWCLR}}$	Asynchronous Clear Minimum Pulse Width for Input DDR	0.22	0.25	0.30	ns
$t_{\text{DDRICKMPWH}}$	Clock Minimum Pulse Width High for Input DDR	0.36	0.41	0.48	ns
$t_{\text{DDRICKMPWL}}$	Clock Minimum Pulse Width Low for Input DDR	0.32	0.37	0.43	ns
F_{DDRIMAX}	Maximum Frequency for Input DDR	1404	1232	1048	MHz

Note: For specific junction temperature and voltage supply levels, refer to Table 2-6 on page 2-6 for derating values.

Output DDR Module

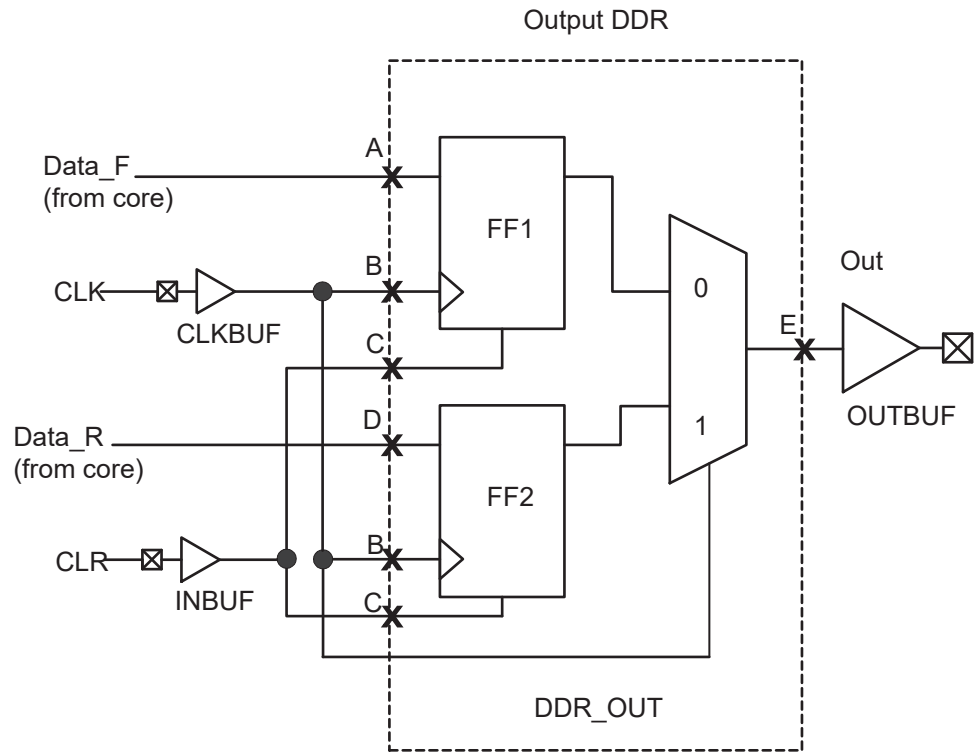

Figure 2-32 • Output DDR Timing Model

Table 2-91 • Parameter Definitions

Parameter Name	Parameter Definition	Measuring Nodes (from, to)
t_{DDROCLKQ}	Clock-to-Out	B, E
$t_{\text{DDROCLR2Q}}$	Asynchronous Clear-to-Out	C, E
$t_{\text{DDROREMCLR}}$	Clear Removal	C, B
$t_{\text{DDRORECCLR}}$	Clear Recovery	C, B
t_{DDROSUD1}	Data Setup Data_F	A, B
t_{DDROSUD2}	Data Setup Data_R	D, B
t_{DDROHD1}	Data Hold Data_F	A, B
t_{DDROHD2}	Data Hold Data_R	D, B

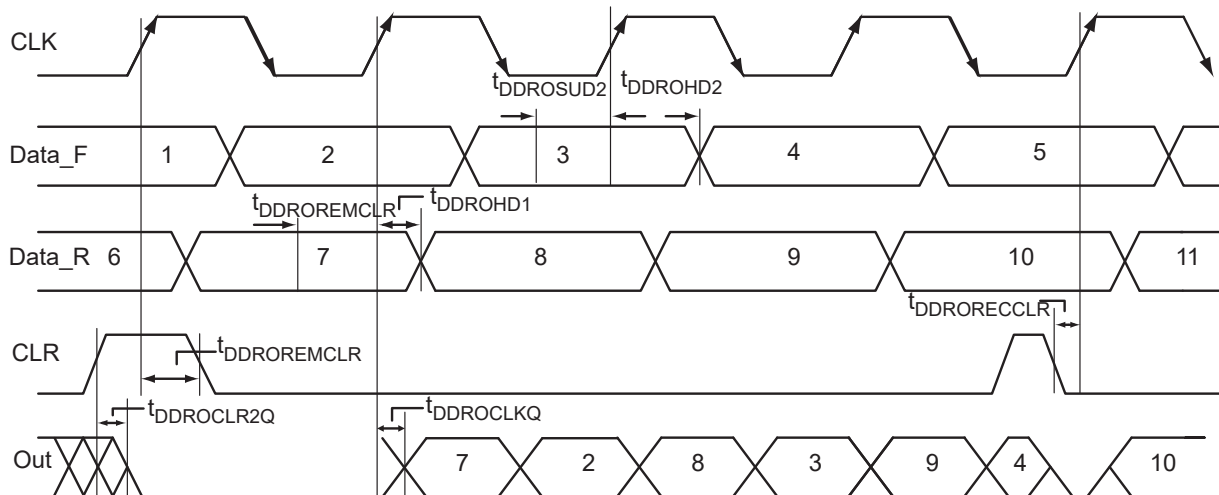

Figure 2-33 • Output DDR Timing Diagram

Timing Characteristics

Table 2-92 • Output DDR Propagation Delays

Commercial-Case Conditions: $T_J = 70^\circ\text{C}$, Worst-Case $V_{CC} = 1.425\text{ V}$

Parameter	Description	-2	-1	Std.	Units
t_{DDROCLKQ}	Clock-to-Out of DDR for Output DDR	0.70	0.80	0.94	ns
t_{DDROSUD1}	Data_F Data Setup for Output DDR	0.38	0.43	0.51	ns
t_{DDROSUD2}	Data_R Data Setup for Output DDR	0.38	0.43	0.51	ns
t_{DDROHD1}	Data_F Data Hold for Output DDR	0.00	0.00	0.00	ns
t_{DDROHD2}	Data_R Data Hold for Output DDR	0.00	0.00	0.00	ns
$t_{\text{DDROCLR2Q}}$	Asynchronous Clear-to-Out for Output DDR	0.80	0.91	1.07	ns
$t_{\text{DDROEMCLR}}$	Asynchronous Clear Removal Time for Output DDR	0.00	0.00	0.00	ns
$t_{\text{DDROECCLR}}$	Asynchronous Clear Recovery Time for Output DDR	0.22	0.25	0.30	ns
$t_{\text{DDROWCLR1}}$	Asynchronous Clear Minimum Pulse Width for Output DDR	0.22	0.25	0.30	ns
$t_{\text{DDROCKMPWH}}$	Clock Minimum Pulse Width High for the Output DDR	0.36	0.41	0.48	ns
$t_{\text{DDROCKMPWL}}$	Clock Minimum Pulse Width Low for the Output DDR	0.32	0.37	0.43	ns
F_{DDOMAX}	Maximum Frequency for the Output DDR	1404	1232	1048	MHz

Note: For specific junction temperature and voltage supply levels, refer to Table 2-6 on page 2-6 for derating values.

VersaTile Characteristics

VersaTile Specifications as a Combinatorial Module

The ProASIC3E library offers all combinations of LUT-3 combinatorial functions. In this section, timing characteristics are presented for a sample of the library. For more details, refer to the *Fusion, IGLOO®/e, and ProASIC3/E Macro Library Guide*.

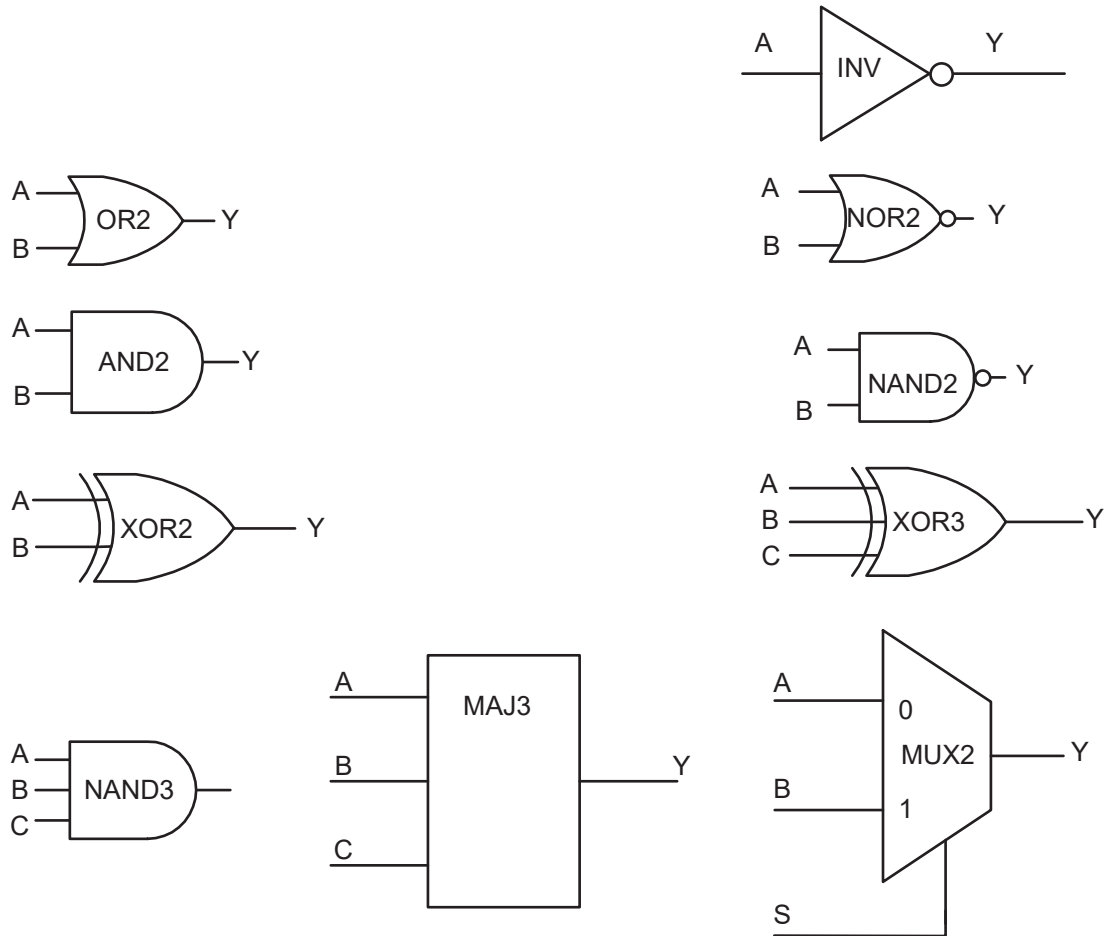

Figure 2-34 • Sample of Combinatorial Cells

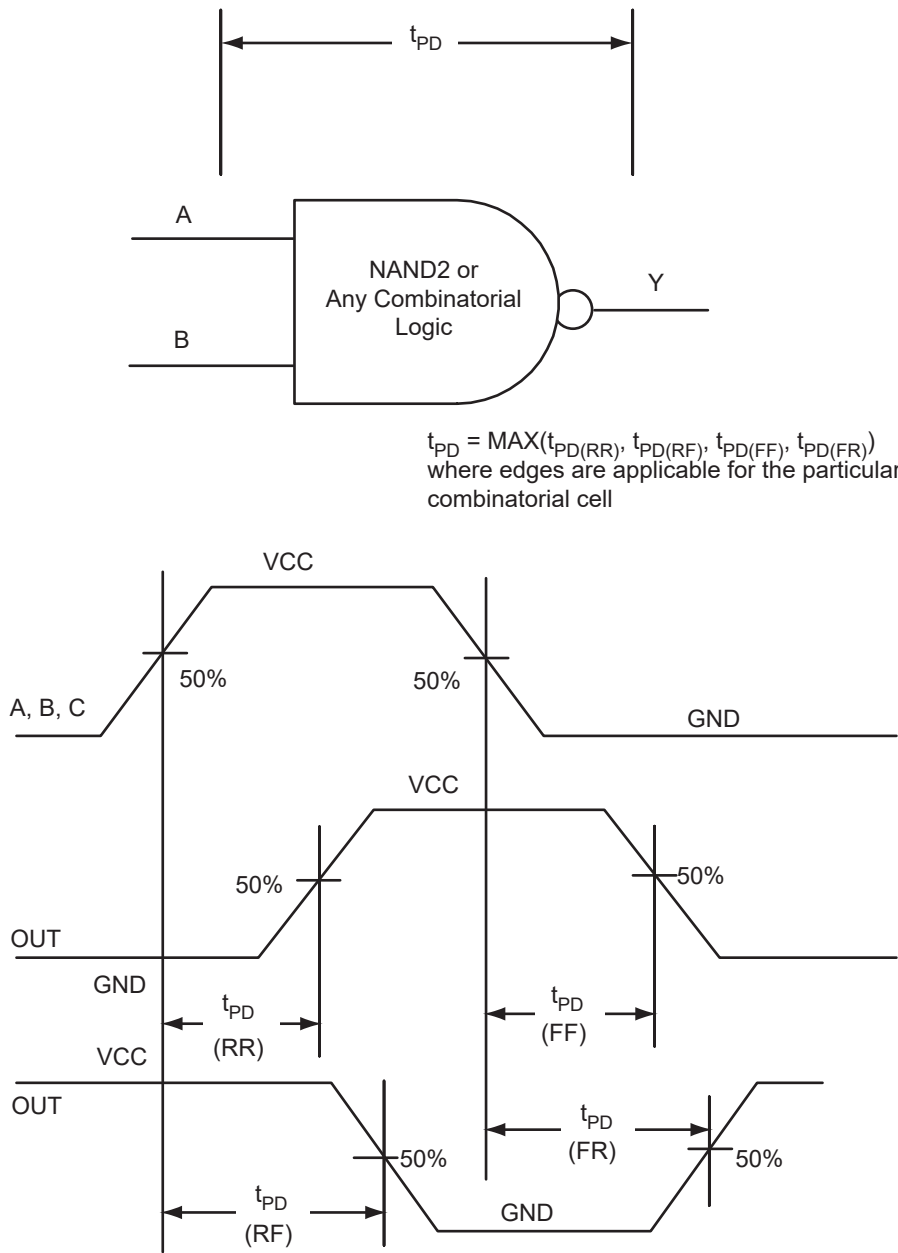

Figure 2-35 • Timing Model and Waveforms

Timing Characteristics

Table 2-93 • Combinatorial Cell Propagation Delays
Commercial-Case Conditions: $T_j = 70^\circ\text{C}$, Worst-Case $V_{CC} = 1.425\text{ V}$

Combinatorial Cell	Equation	Parameter	-2	-1	Std.	Units
INV	$Y = !A$	t_{PD}	0.40	0.46	0.54	ns
AND2	$Y = A \cdot B$	t_{PD}	0.47	0.54	0.63	ns
NAND2	$Y = !(A \cdot B)$	t_{PD}	0.47	0.54	0.63	ns
OR2	$Y = A + B$	t_{PD}	0.49	0.55	0.65	ns
NOR2	$Y = !(A + B)$	t_{PD}	0.49	0.55	0.65	ns
XOR2	$Y = A \oplus B$	t_{PD}	0.74	0.84	0.99	ns
MAJ3	$Y = \text{MAJ}(A, B, C)$	t_{PD}	0.70	0.79	0.93	ns
XOR3	$Y = A \oplus B \oplus C$	t_{PD}	0.87	1.00	1.17	ns
MUX2	$Y = A !S + B S$	t_{PD}	0.51	0.58	0.68	ns
AND3	$Y = A \cdot B \cdot C$	t_{PD}	0.56	0.64	0.75	ns

Note: For specific junction temperature and voltage supply levels, refer to Table 2-6 on page 2-6 for derating values.

VersaTile Specifications as a Sequential Module

The ProASIC3E library offers a wide variety of sequential cells, including flip-flops and latches. Each has a data input and optional enable, clear, or preset. In this section, timing characteristics are presented for a representative sample from the library. For more details, refer to the *Fusion, IGLOO/e, and ProASIC3/E Macro Library Guide*.

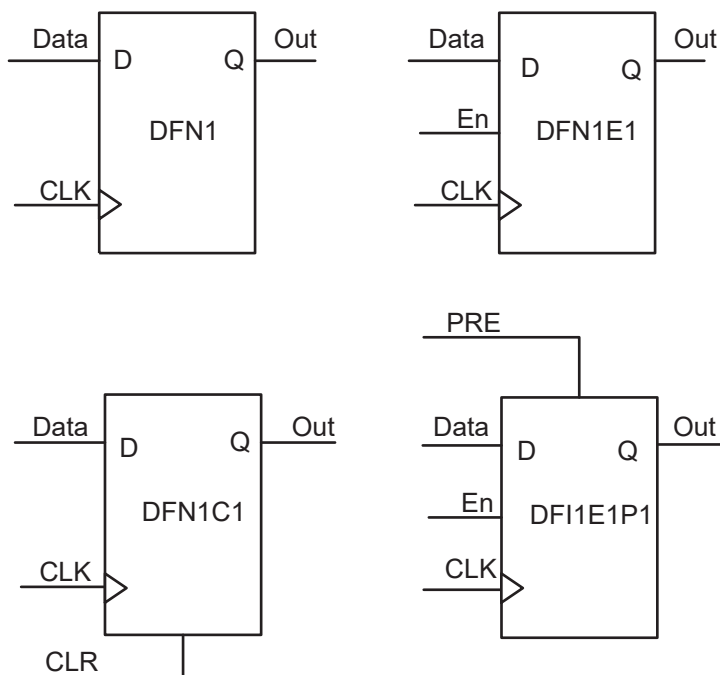

Figure 2-36 • Sample of Sequential Cells

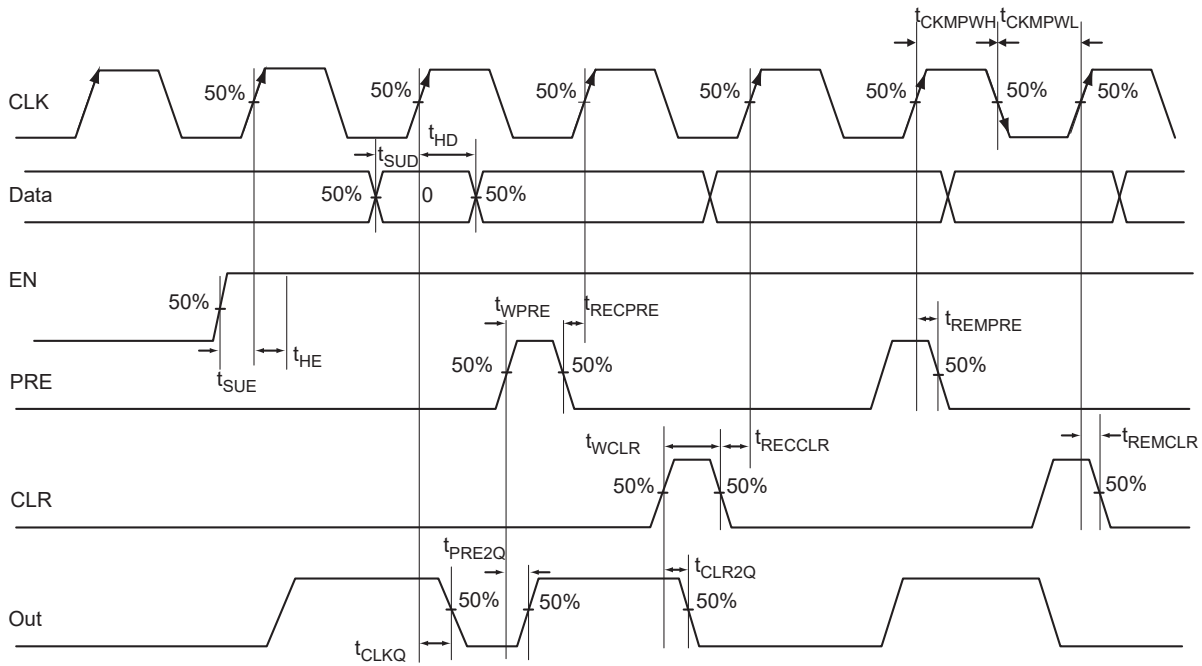

Figure 2-37 • Timing Model and Waveforms

Timing Characteristics

Table 2-94 • Register Delays

Commercial-Case Conditions: $T_j = 70^\circ\text{C}$, Worst-Case $V_{CC} = 1.425\text{ V}$

Parameter	Description	-2	-1	Std.	Units
t_{CLKQ}	Clock-to-Q of the Core Register	0.55	0.63	0.74	ns
t_{SUD}	Data Setup Time for the Core Register	0.43	0.49	0.57	ns
t_{HD}	Data Hold Time for the Core Register	0.00	0.00	0.00	ns
t_{SUE}	Enable Setup Time for the Core Register	0.45	0.52	0.61	ns
t_{HE}	Enable Hold Time for the Core Register	0.00	0.00	0.00	ns
t_{CLR2Q}	Asynchronous Clear-to-Q of the Core Register	0.40	0.45	0.53	ns
t_{PRE2Q}	Asynchronous Preset-to-Q of the Core Register	0.40	0.45	0.53	ns
t_{REMCLR}	Asynchronous Clear Removal Time for the Core Register	0.00	0.00	0.00	ns
t_{RECCLR}	Asynchronous Clear Recovery Time for the Core Register	0.22	0.25	0.30	ns
t_{REMPRE}	Asynchronous Preset Removal Time for the Core Register	0.00	0.00	0.00	ns
t_{RECPRE}	Asynchronous Preset Recovery Time for the Core Register	0.22	0.25	0.30	ns
t_{WCLR}	Asynchronous Clear Minimum Pulse Width for the Core Register	0.22	0.25	0.30	ns
t_{WPRE}	Asynchronous Preset Minimum Pulse Width for the Core Register	0.22	0.25	0.30	ns
t_{CKMPWH}	Clock Minimum Pulse Width High for the Core Register	0.32	0.37	0.43	ns
t_{CKMPWL}	Clock Minimum Pulse Width Low for the Core Register	0.36	0.41	0.48	ns

Note: For specific junction temperature and voltage supply levels, refer to [Table 2-6 on page 2-6](#) for derating values.

Global Resource Characteristics

A3PE600 Clock Tree Topology

Clock delays are device-specific. [Figure 2-38](#) is an example of a global tree used for clock routing. The global tree presented in [Figure 2-38](#) is driven by a CCC located on the west side of the A3PE600 device. It is used to drive all D-

flip-flops in the device.

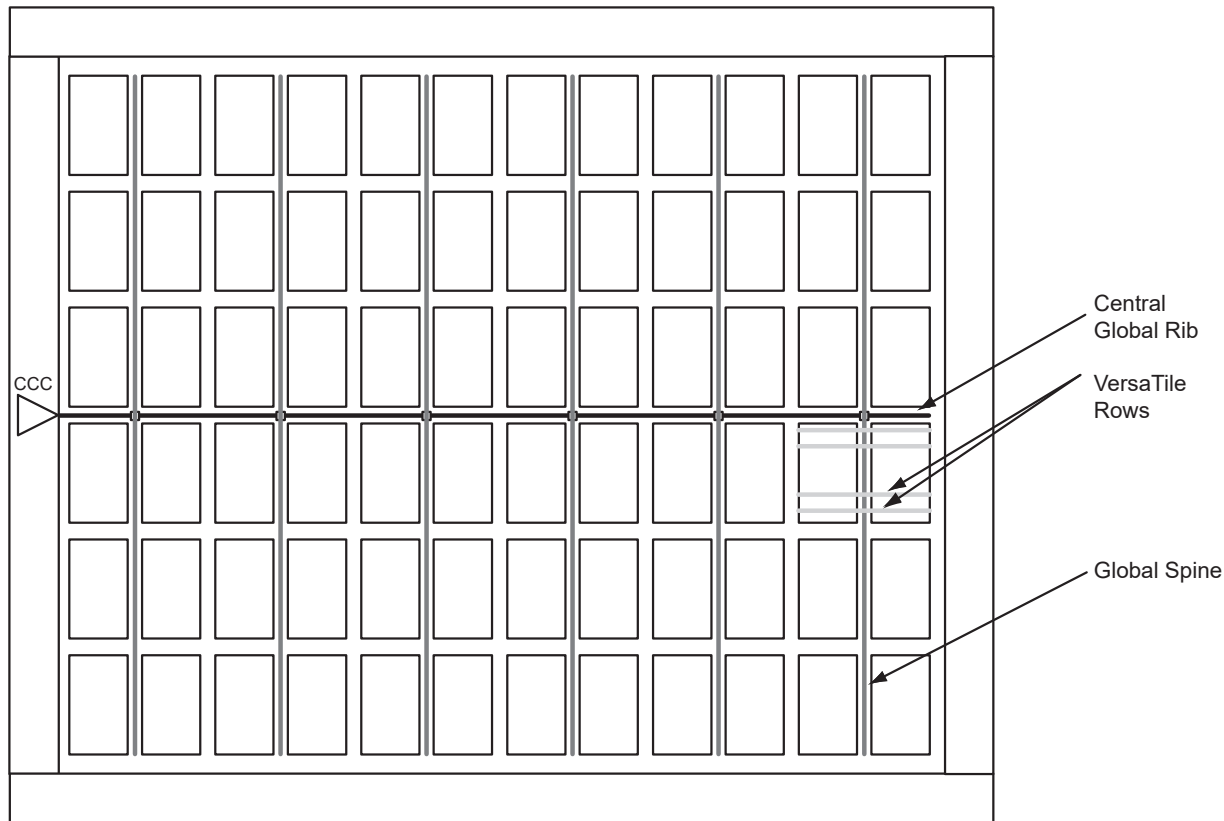

Figure 2-38 • Example of Global Tree Use in an A3PE600 Device for Clock Routing

Global Tree Timing Characteristics

Global clock delays include the central rib delay, the spine delay, and the row delay. Delays do not include I/O input buffer clock delays, as these are I/O standard-dependent, and the clock may be driven and conditioned internally by the CCC module. For more details on clock conditioning capabilities, refer to the "Clock Conditioning Circuits" section on page 2-73. Table 2-95 on page 2-72, Table 2-96 on page 2-72, and Table 2-97 on page 2-72 present minimum and maximum global clock delays within the device. Minimum and maximum delays are measured with minimum and maximum loading.

Timing Characteristics

Table 2-95 • A3PE600 Global Resource
Commercial-Case Conditions: $T_J = 70^\circ\text{C}$, $V_{CC} = 1.425\text{ V}$

Parameter	Description	-2		-1		Std.		Units
		Min. ¹	Max. ²	Min. ¹	Max. ²	Min. ¹	Max. ²	
t _{RCKL}	Input Low Delay for Global Clock	0.83	1.04	0.94	1.18	1.11	1.39	ns
t _{RCKH}	Input High Delay for Global Clock	0.81	1.06	0.93	1.21	1.09	1.42	ns
t _{RCKMPWH}	Minimum Pulse Width High for Global Clock	0.75		0.85		1.00		ns
t _{RCKMPWL}	Minimum Pulse Width Low for Global Clock	0.85		0.96		1.13		ns
t _{RCKSW}	Maximum Skew for Global Clock		0.25		0.28		0.33	ns

Notes:

1. Value reflects minimum load. The delay is measured from the CCC output to the clock pin of a sequential element, located in a lightly loaded row (single element is connected to the global net).
2. Value reflects maximum load. The delay is measured on the clock pin of the farthest sequential element, located in a fully loaded row (all available flip-flops are connected to the global net in the row).
3. For specific junction temperature and voltage supply levels, refer to [Table 2-6 on page 2-6](#) for derating values.

Table 2-96 • A3PE1500 Global Resource
Commercial-Case Conditions: $T_J = 70^\circ\text{C}$, $V_{CC} = 1.425\text{ V}$

Parameter	Description	-2		-1		Std.		Units
		Min. ¹	Max. ²	Min. ¹	Max. ²	Min. ¹	Max. ²	
t _{RCKL}	Input Low Delay for Global Clock	1.07	1.29	1.22	1.47	1.43	1.72	ns
t _{RCKH}	Input High Delay for Global Clock	1.06	1.32	1.21	1.50	1.42	1.76	ns
t _{RCKMPWH}	Minimum Pulse Width High for Global Clock	0.75		0.85		1.00		ns
t _{RCKMPWL}	Minimum Pulse Width Low for Global Clock	0.85		0.96		1.13		ns
t _{RCKSW}	Maximum Skew for Global Clock		0.26		0.29		0.34	ns

Notes:

1. Value reflects minimum load. The delay is measured from the CCC output to the clock pin of a sequential element, located in a lightly loaded row (single element is connected to the global net).
2. Value reflects maximum load. The delay is measured on the clock pin of the farthest sequential element, located in a fully loaded row (all available flip-flops are connected to the global net in the row).
3. For specific junction temperature and voltage supply levels, refer to [Table 2-6 on page 2-6](#) for derating values.

Table 2-97 • A3PE3000 Global Resource
Commercial-Case Conditions: $T_J = 70^\circ\text{C}$, $V_{CC} = 1.425\text{ V}$

Parameter	Description	-2		-1		Std.		Units
		Min. ¹	Max. ²	Min. ¹	Max. ²	Min. ¹	Max. ²	
t _{RCKL}	Input Low Delay for Global Clock	1.41	1.62	1.60	1.85	1.88	2.17	ns
t _{RCKH}	Input High Delay for Global Clock	1.40	1.66	1.59	1.89	1.87	2.22	ns
t _{RCKMPWH}	Minimum Pulse Width High for Global Clock	0.75		0.85		1.00		ns
t _{RCKMPWL}	Minimum Pulse Width Low for Global Clock	0.85		0.96		1.13		ns
t _{RCKSW}	Maximum Skew for Global Clock		0.26		0.29		0.35	ns

Notes:

1. Value reflects minimum load. The delay is measured from the CCC output to the clock pin of a sequential element, located in a lightly loaded row (single element is connected to the global net).
2. Value reflects maximum load. The delay is measured on the clock pin of the farthest sequential element, located in a fully loaded row (all available flip-flops are connected to the global net in the row).
3. For specific junction temperature and voltage supply levels, refer to [Table 2-6 on page 2-6](#) for derating values.

Clock Conditioning Circuits

CCC Electrical Specifications

Timing Characteristics

Table 2-98 • ProASIC3E CCC/PLL Specification

Parameter	Minimum	Typical	Maximum	Units
Clock Conditioning Circuitry Input Frequency f_{IN_CCC}	1.5		350	MHz
Clock Conditioning Circuitry Output Frequency f_{OUT_CCC}	0.75		350	MHz
Delay Increments in Programmable Delay Blocks ^{1, 2}		160 ³		ps
Serial Clock (SCLK) for Dynamic PLL ⁴			125	MHz
Number of Programmable Values in Each Programmable Delay Block			32	
Input Period Jitter			1.5	ns
CCC Output Peak-to-Peak Period Jitter F_{CCC_OUT}	Max Peak-to-Peak Period Jitter			
	1 Global Network Used		3 Global Networks Used	
0.75 MHz to 24 MHz	0.50%		0.70%	
24 MHz to 100 MHz	1.00%		1.20%	
100 MHz to 250 MHz	1.75%		2.00%	
250 MHz to 350 MHz	2.50%		5.60%	
Acquisition Time	LockControl = 0		300	μs
	LockControl = 1		6.0	ms
Tracking Jitter ⁵	LockControl = 0		1.6	ns
	LockControl = 1		0.8	ns
Output Duty Cycle	48.5		51.5	%
Delay Range in Block: Programmable Delay 1 ^{1, 2}	0.6		5.56	ns
Delay Range in Block: Programmable Delay 2 ^{1, 2}	0.025		5.56	ns
Delay Range in Block: Fixed Delay ^{1, 4}		2.2		ns

Notes:

1. This delay is a function of voltage and temperature. See [Table 2-6 on page 2-6](#) for deratings
2. $T_J = 25^\circ\text{C}$, $V_{CC} = 1.5\text{ V}$.
3. When the CCC/PLL core is generated by Microsemi core generator software, not all delay values of the specified delay increments are available. Refer to the Libero SoC Online Help for more information.
4. Maximum value obtained for a -2 speed-grade device in worst-case commercial conditions. For specific junction temperature and voltage supply levels, refer to [Table 2-6 on page 2-6](#) for derating values.
5. Tracking jitter is defined as the variation in clock edge position of PLL outputs with reference to the PLL input clock edge. Tracking jitter does not measure the variation in PLL output period, which is covered by the period jitter parameter.

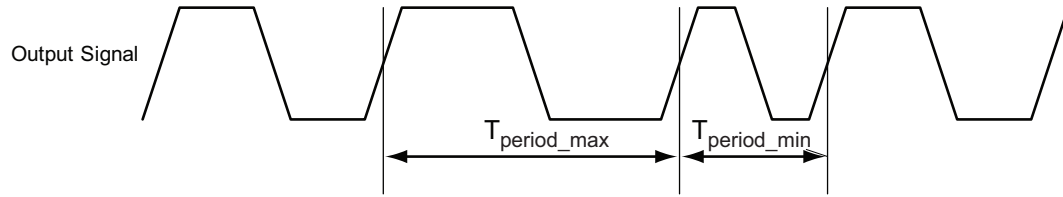

Note: Peak-to-peak jitter measurements are defined by $T_{\text{peak-to-peak}} = T_{\text{period_max}} - T_{\text{period_min}}$.

Figure 2-39 • Peak-to-Peak Jitter Definition

Embedded SRAM and FIFO Characteristics

SRAM

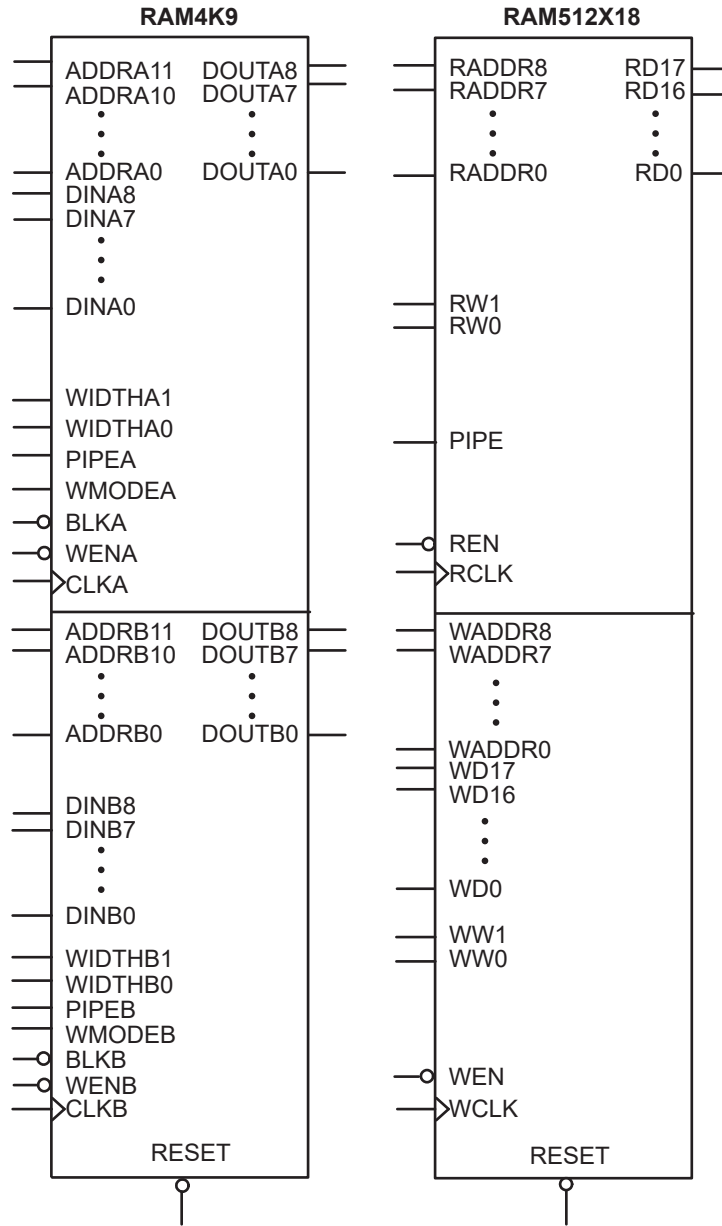

Figure 2-40 • RAM Models

Timing Waveforms

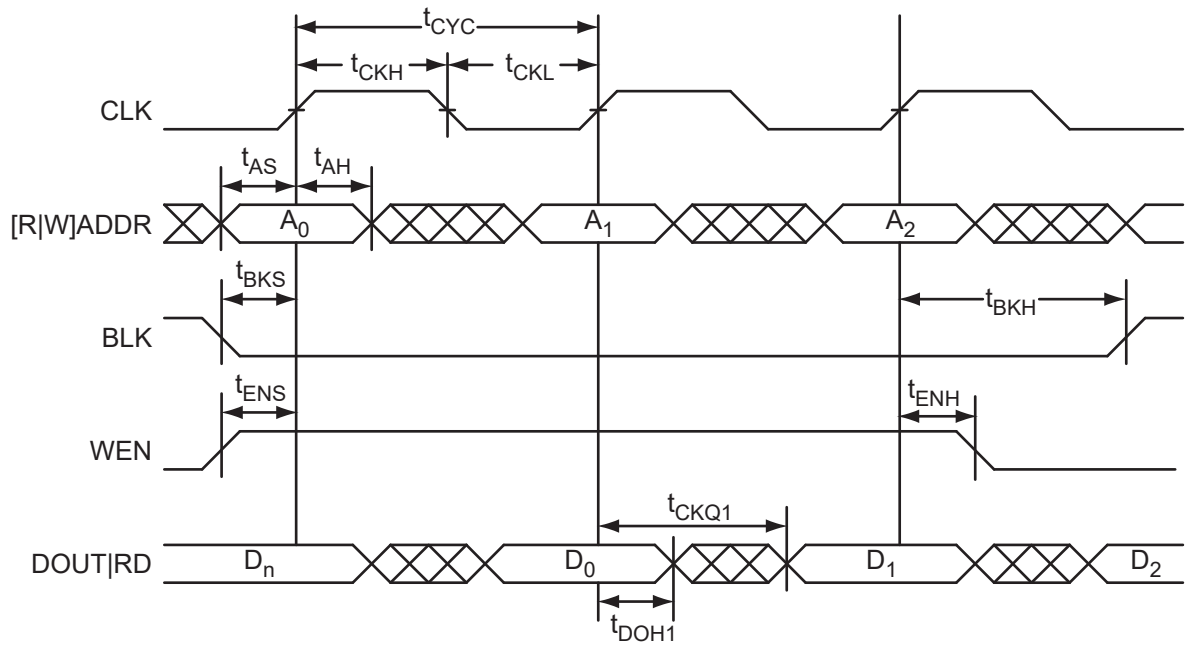

Figure 2-41 • RAM Read for Pass-Through Output. Applicable to Both RAM4K9 and RAM512x18.

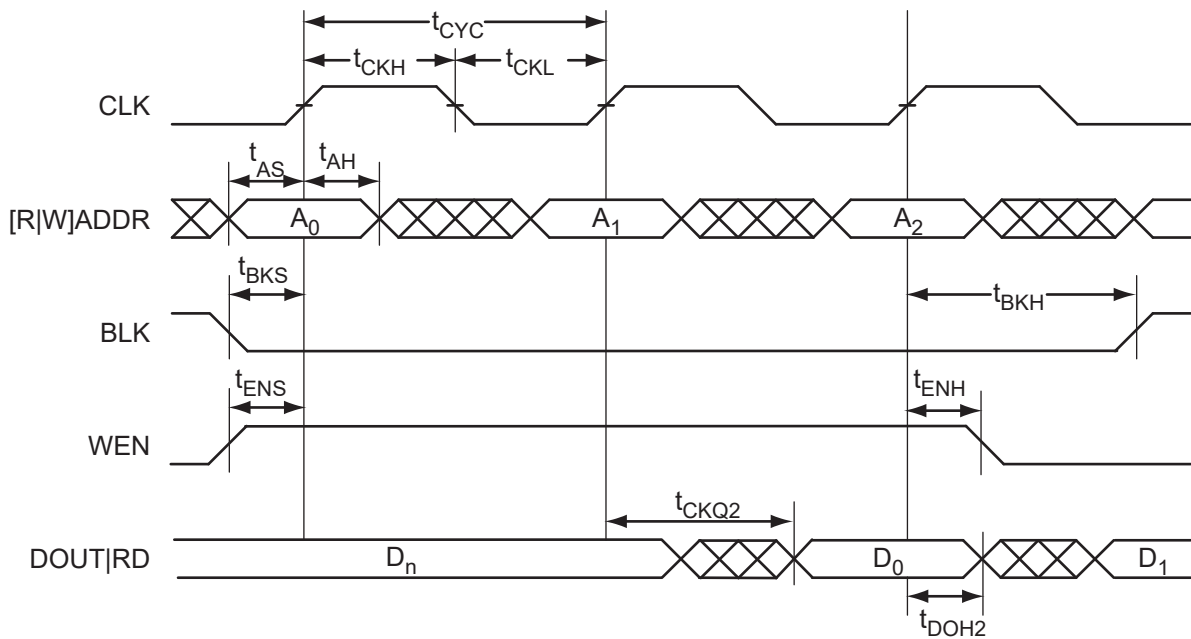

Figure 2-42 • RAM Read for Pipelined Output. Applicable to Both RAM4K9 and RAM512x18.

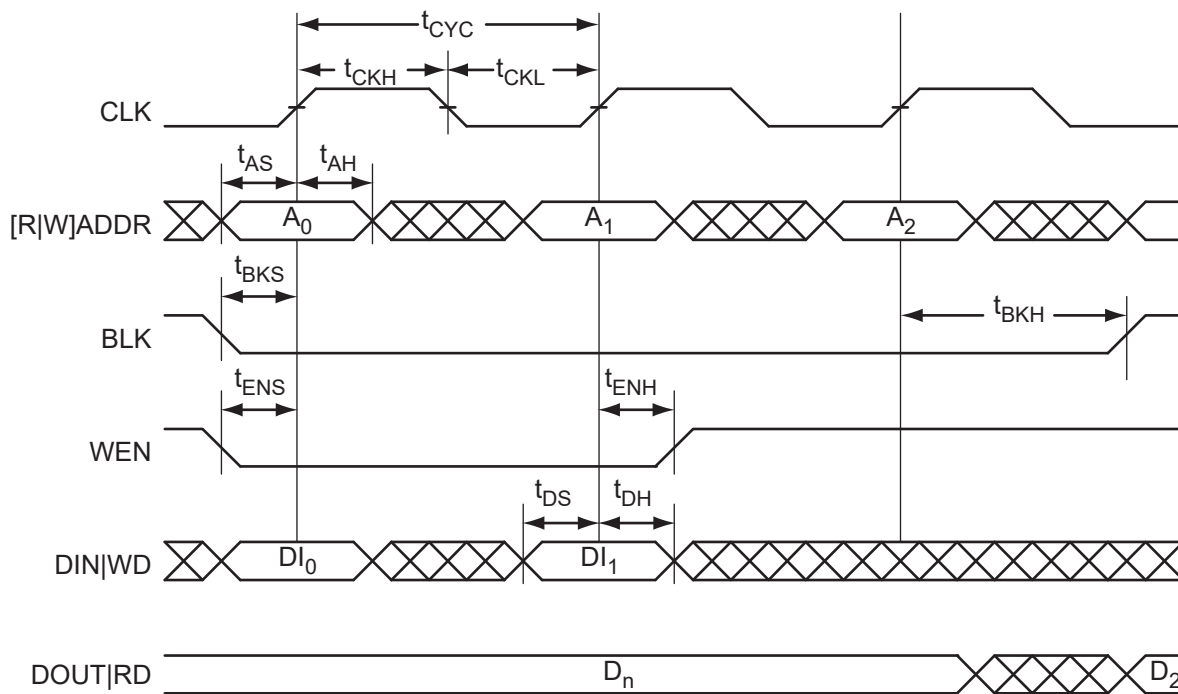

Figure 2-43 • RAM Write, Output Retained. Applicable to Both RAM4K9 and RAM512x18.

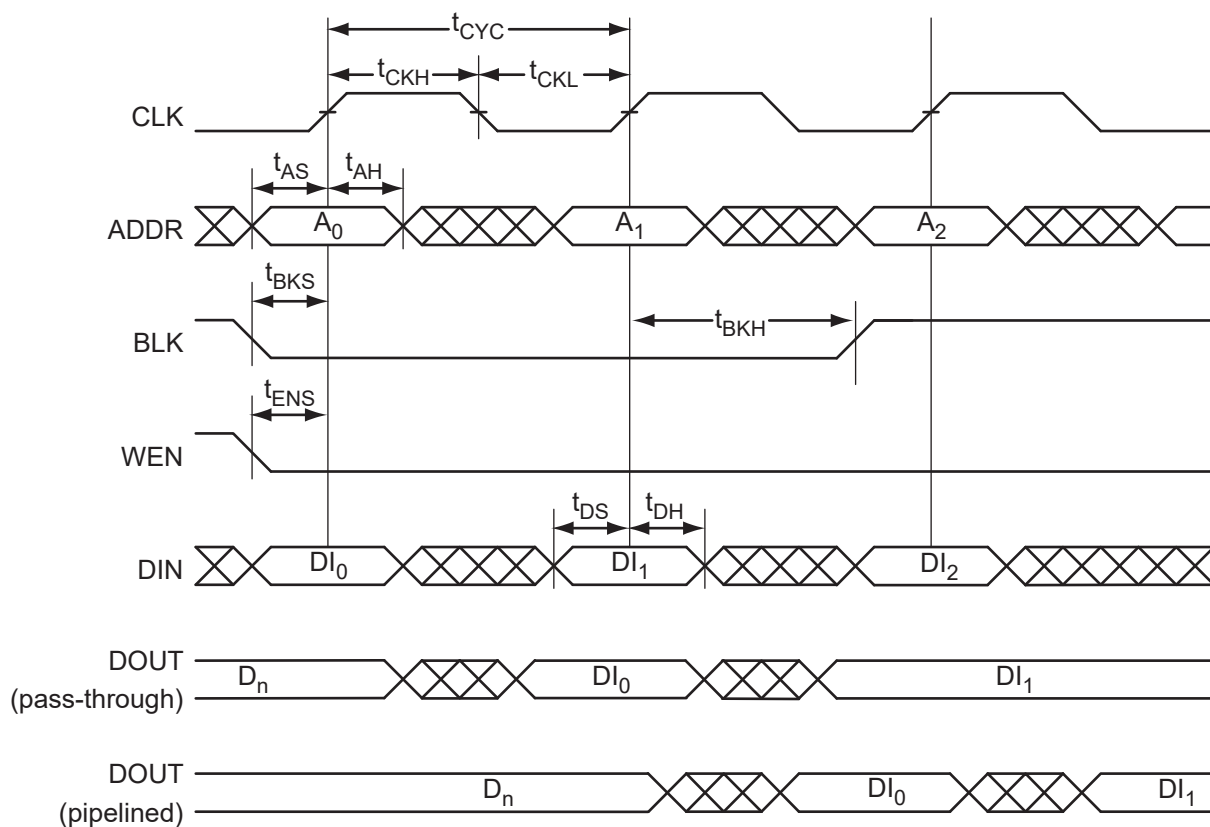

Figure 2-44 • RAM Write, Output as Write Data. Applicable to RAM4K9 Only.

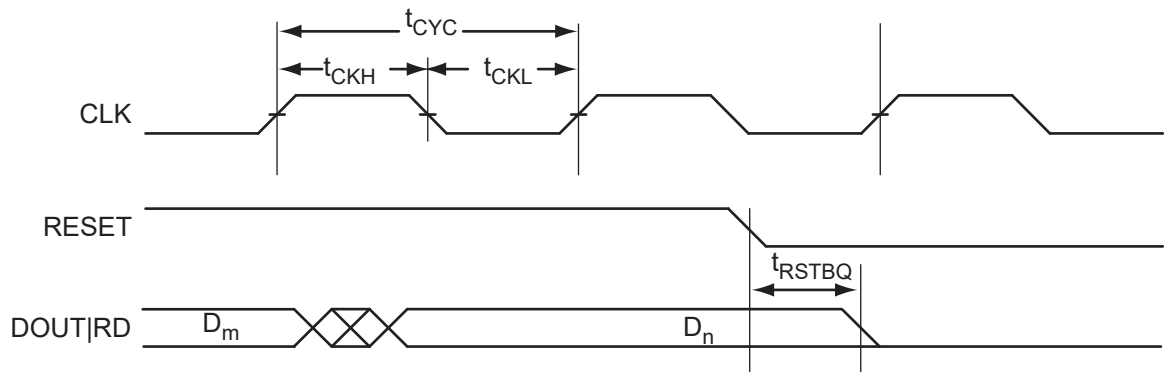

Figure 2-45 • RAM Reset. Applicable to Both RAM4K9 and RAM512x18.

Timing Characteristics

Table 2-99 • RAM4K9

 Commercial-Case Conditions: $T_j = 70^\circ\text{C}$, Worst-Case $V_{CC} = 1.425\text{ V}$

Parameter	Description	-2	-1	Std.	Units
t_{AS}	Address setup time	0.25	0.28	0.33	ns
t_{AH}	Address hold time	0.00	0.00	0.00	ns
t_{ENS}	REN, WEN setup time	0.14	0.16	0.19	ns
t_{ENH}	REN, WEN hold time	0.10	0.11	0.13	ns
t_{BKS}	BLK setup time	0.23	0.27	0.31	ns
t_{BKH}	BLK hold time	0.02	0.02	0.02	ns
t_{DS}	Input data (DIN) setup time	0.18	0.21	0.25	ns
t_{DH}	Input data (DIN) hold time	0.00	0.00	0.00	ns
t_{CKQ1}	Clock High to new data valid on DOUT (output retained, WMODE = 0)	1.79	2.03	2.39	ns
	Clock High to new data valid on DOUT (flow-through, WMODE = 1)	2.36	2.68	3.15	ns
t_{CKQ2}	Clock High to new data valid on DOUT (pipelined)	0.89	1.02	1.20	ns
t_{C2CWWL}^1	Address collision clk-to-clk delay for reliable write after write on same address—Applicable to Closing Edge	0.33	0.28	0.25	ns
t_{C2CWWH}^1	Address collision clk-to-clk delay for reliable write after write on same address—Applicable to Rising Edge	0.30	0.26	0.23	ns
t_{C2CRWH}^1	Address collision clk-to-clk delay for reliable read access after write on same address—Applicable to Opening Edge	0.45	0.38	0.34	ns
t_{C2CWRH}^1	Address collision clk-to-clk delay for reliable write access after read on same address— Applicable to Opening Edge	0.49	0.42	0.37	ns
t_{RSTBQ}	RESET Low to data out Low on DO (flow-through)	0.92	1.05	1.23	ns
	RESET Low to Data Out Low on DO (pipelined)	0.92	1.05	1.23	ns
$t_{REMRSTB}$	RESET removal	0.29	0.33	0.38	ns
$t_{RECRSTB}$	RESET recovery	1.50	1.71	2.01	ns
$t_{MPWRSTB}$	RESET minimum pulse width	0.21	0.24	0.29	ns
t_{CYC}	Clock cycle time	3.23	3.68	4.32	ns
F_{MAX}	Maximum frequency	310	272	231	MHz

Notes:

1. For more information, refer to the application note [Simultaneous Read-Write Operations in Dual-Port SRAM for Flash-Based cSoCs and FPGAs](#).
2. For specific junction temperature and voltage supply levels, refer to [Table 2-6 on page 2-6](#) for derating values.

Table 2-100 • RAM512X18
Commercial-Case Conditions: $T_J = 70^\circ\text{C}$, Worst-Case $V_{CC} = 1.425\text{ V}$

Parameter	Description	-2	-1	Std.	Units
t_{AS}	Address setup time	0.25	0.28	0.33	ns
t_{AH}	Address hold time	0.00	0.00	0.00	ns
t_{ENS}	REN, WEN setup time	0.18	0.20	0.24	ns
t_{ENH}	REN, WEN hold time	0.06	0.07	0.08	ns
t_{DS}	Input data (WD) setup time	0.18	0.21	0.25	ns
t_{DH}	Input data (WD) hold time	0.00	0.00	0.00	ns
t_{CKQ1}	Clock High to new data valid on RD (output retained)	2.16	2.46	2.89	ns
t_{CKQ2}	Clock High to new data valid on RD (pipelined)	0.90	1.02	1.20	ns
t_{C2CRWH}^1	Address collision clk-to-clk delay for reliable read access after write on same address—Applicable to Opening Edge	0.50	0.43	0.38	ns
t_{C2CWRH}^1	Address collision clk-to-clk delay for reliable write access after read on same address—Applicable to Opening Edge	0.59	0.50	0.44	ns
t_{RSTBQ}	RESET Low to data out Low on RD (flow-through)	0.92	1.05	1.23	ns
	RESET Low to data out Low on RD (pipelined)	0.92	1.05	1.23	ns
$t_{REMRSTB}$	RESET removal	0.29	0.33	0.38	ns
$t_{RECRSTB}$	RESET recovery	1.50	1.71	2.01	ns
$t_{MPWRSTB}$	RESET minimum pulse width	0.21	0.24	0.29	ns
t_{CYC}	Clock cycle time	3.23	3.68	4.32	ns
F_{MAX}	Maximum frequency	310	272	231	MHz

Notes:

1. For more information, refer to the application note [Simultaneous Read-Write Operations in Dual-Port SRAM for Flash-Based cSoCs and FPGAs](#).
2. For specific junction temperature and voltage supply levels, refer to [Table 2-6 on page 2-6](#) for derating values.

FIFO

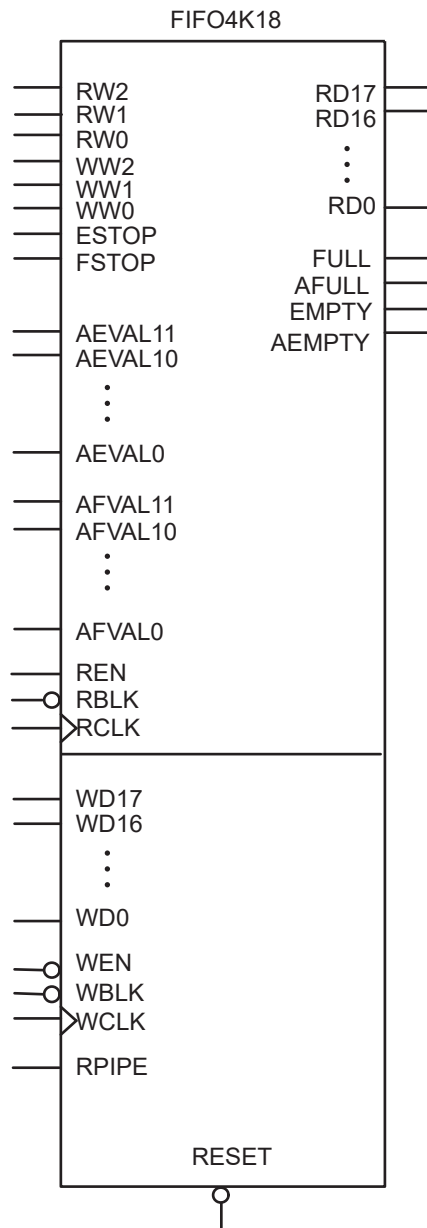

Figure 2-46 • FIFO Model

Timing Waveforms

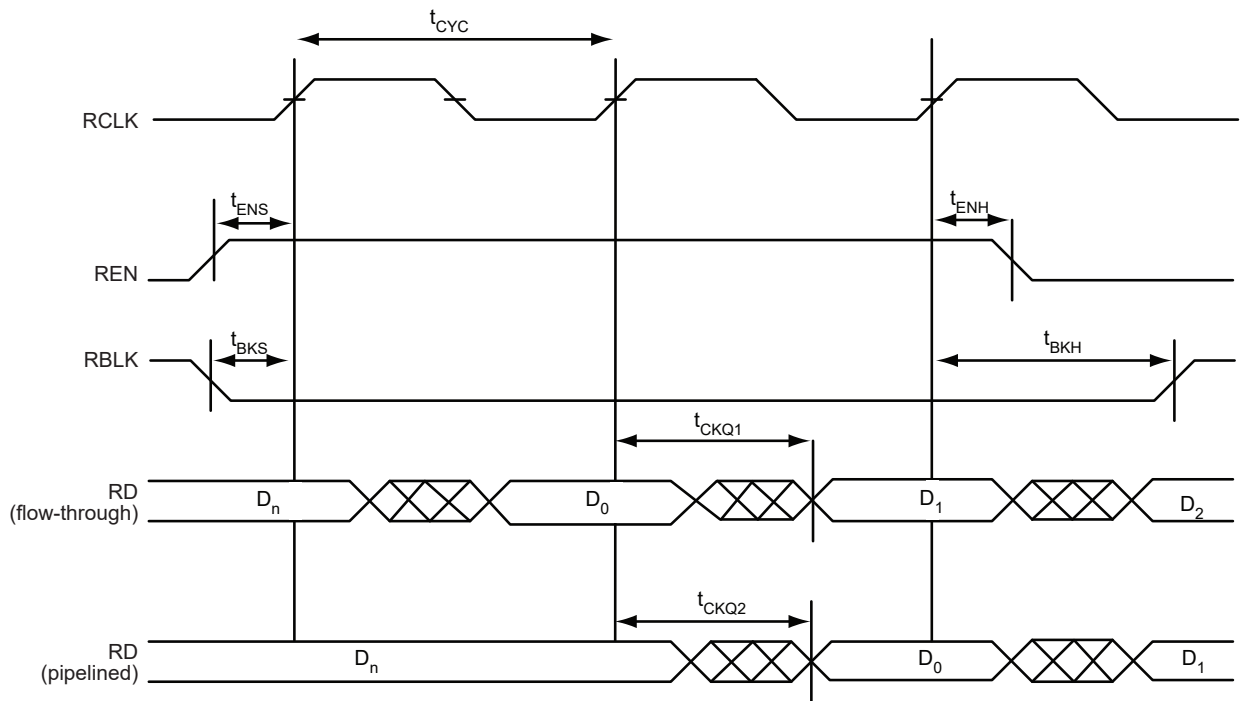

Figure 2-47 • FIFO Read

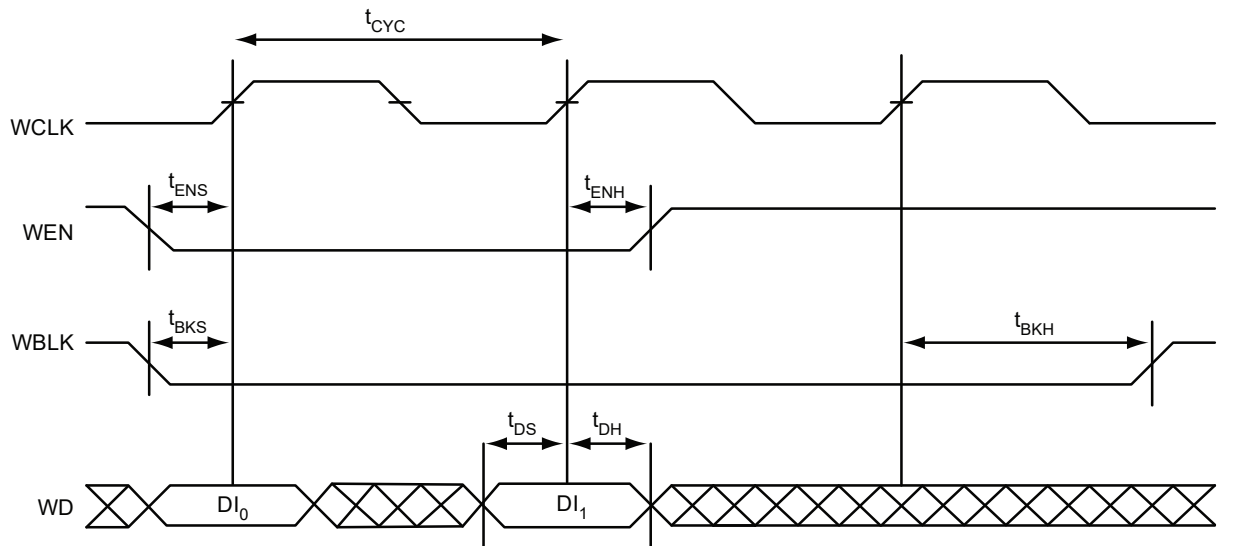

Figure 2-48 • FIFO Write

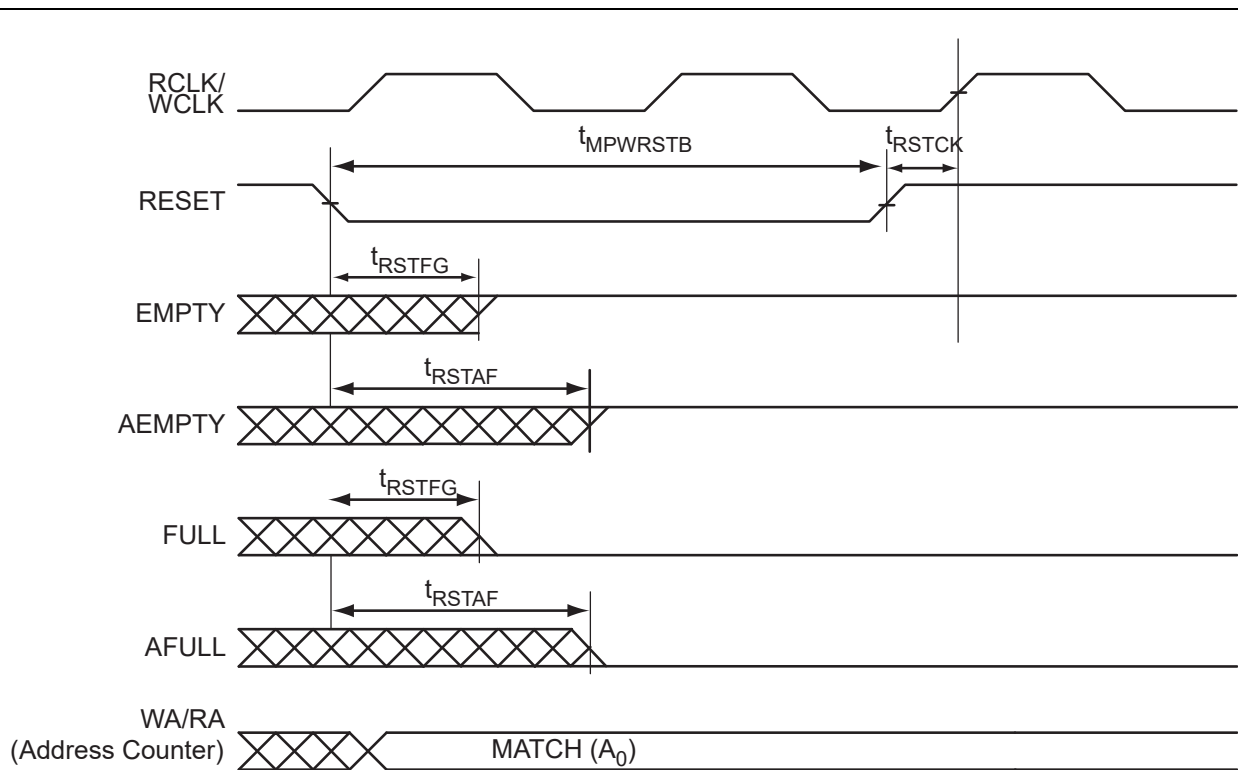

Figure 2-49 • FIFO Reset

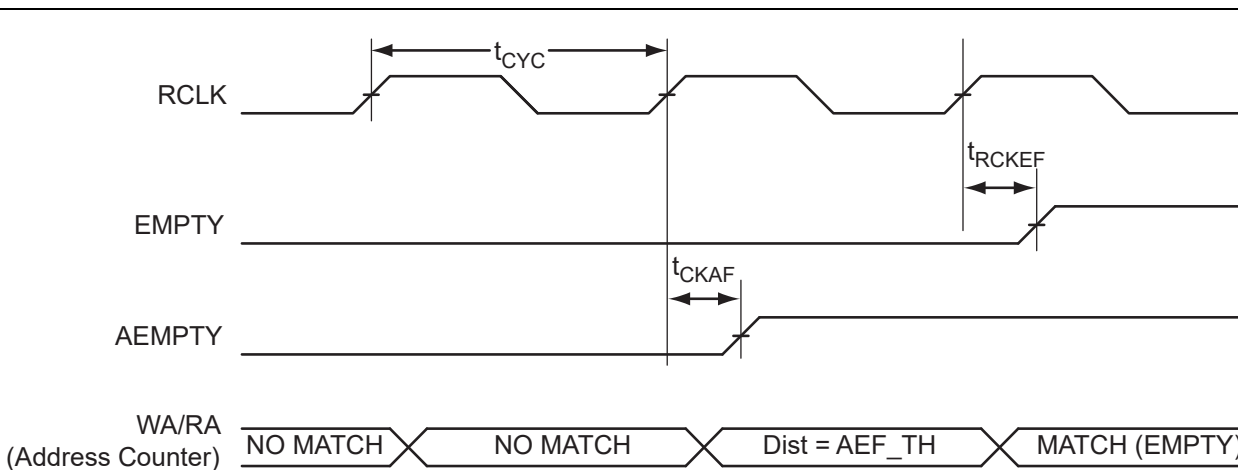

Figure 2-50 • FIFO EMPTY Flag and AEMPTY Flag Assertion

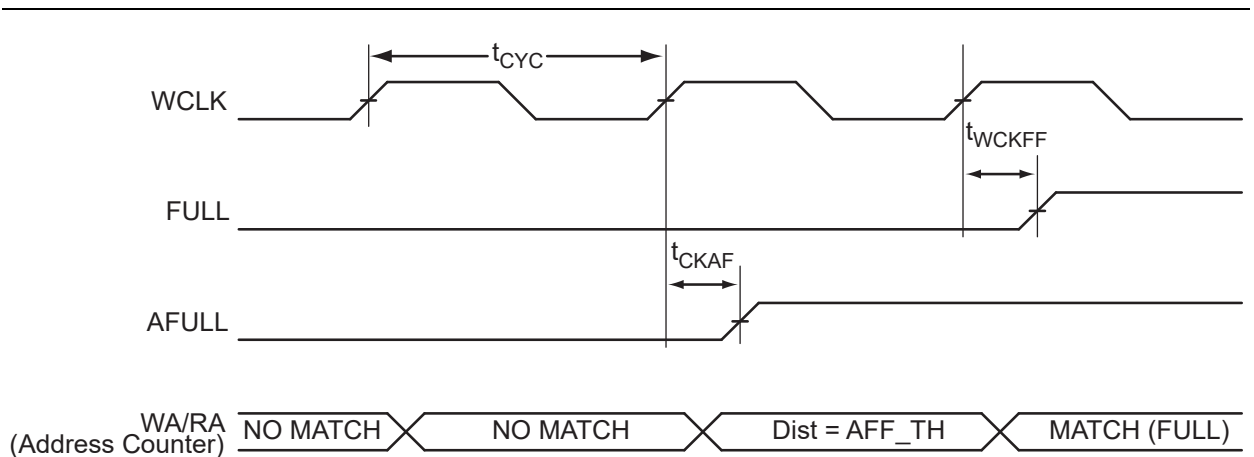

Figure 2-51 • FIFO FULL Flag and AFULL Flag Assertion

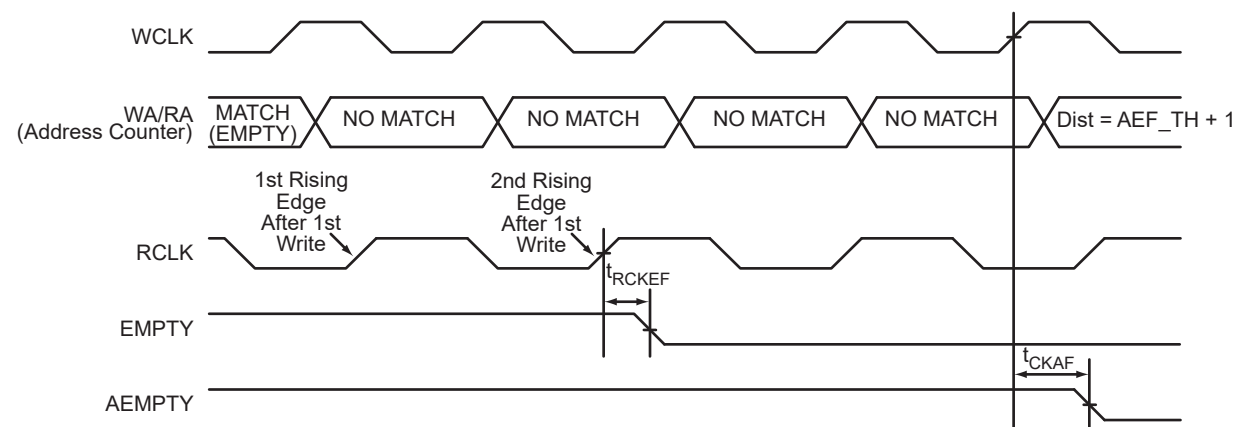

Figure 2-52 • FIFO EMPTY Flag and AEMPTY Flag Deassertion

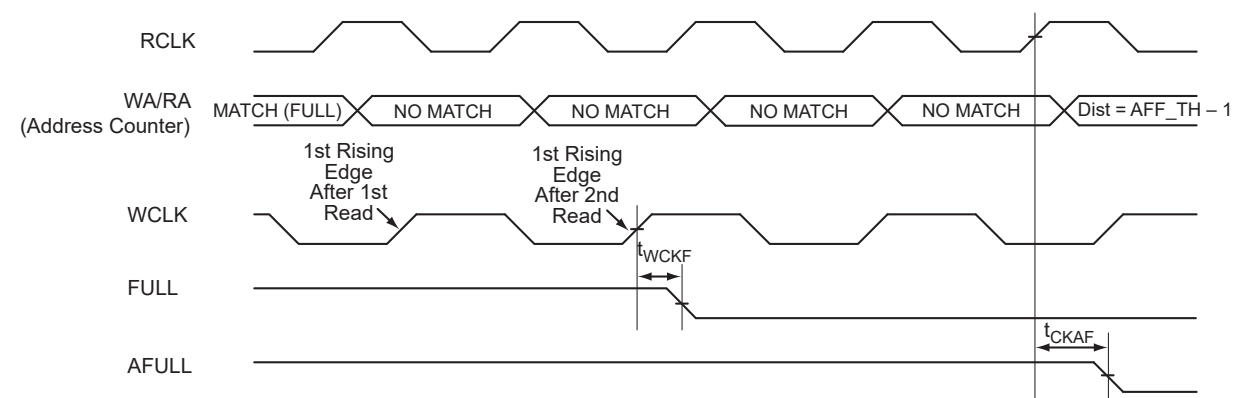

Figure 2-53 • FIFO FULL Flag and AFULL Flag Deassertion

Timing Characteristics

Table 2-101 • FIFO

Commercial-Case Conditions: $T_j = 70^\circ\text{C}$, $V_{CC} = 1.425\text{ V}$

Parameter	Description	-2	-1	Std.	Units
t_{ENS}	REN, WEN Setup Time	1.38	1.57	1.84	ns
t_{ENH}	REN, WEN Hold Time	0.02	0.02	0.02	ns
t_{BKS}	BLK Setup Time	0.19	0.22	0.26	ns
t_{BKH}	BLK Hold Time	0.00	0.00	0.00	ns
t_{DS}	Input Data (WD) Setup Time	0.18	0.21	0.25	ns
t_{DH}	Input Data (WD) Hold Time	0.00	0.00	0.00	ns
t_{CKQ1}	Clock High to New Data Valid on RD (pass-through)	2.36	2.68	3.15	ns
t_{CKQ2}	Clock High to New Data Valid on RD (pipelined)	0.89	1.02	1.20	ns
t_{RCKEF}	RCLK High to Empty Flag Valid	1.72	1.96	2.30	ns
t_{WCKFF}	WCLK High to Full Flag Valid	1.63	1.86	2.18	ns
t_{CKAF}	Clock High to Almost Empty/Full Flag Valid	6.19	7.05	8.29	ns
t_{RSTFG}	RESET Low to Empty/Full Flag Valid	1.69	1.93	2.27	ns
t_{RSTAF}	RESET Low to Almost Empty/Full Flag Valid	6.13	6.98	8.20	ns
t_{RSTBQ}	RESET Low to Data Out Low on RD (pass-through)	0.92	1.05	1.23	ns
	RESET Low to Data Out Low on RD (pipelined)	0.92	1.05	1.23	ns
$t_{REMRSTB}$	RESET Removal	0.29	0.33	0.38	ns
$t_{RECRSTB}$	RESET Recovery	1.50	1.71	2.01	ns
$t_{MPWRSTB}$	RESET Minimum Pulse Width	0.21	0.24	0.29	ns
t_{CYC}	Clock Cycle Time	3.23	3.68	4.32	ns
F_{MAX}	Maximum Frequency	310	272	231	MHz

Note: For specific junction temperature and voltage supply levels, refer to Table 2-6 on page 2-6 for derating values.

3 – Pin Descriptions and Packaging

Supply Pins

GND**Ground**

Ground supply voltage to the core, I/O outputs, and I/O logic.

GNDQ**Ground (quiet)**

Quiet ground supply voltage to input buffers of I/O banks. Within the package, the GNDQ plane is decoupled from the simultaneous switching noise originated from the output buffer ground domain. This minimizes the noise transfer within the package and improves input signal integrity. GNDQ must always be connected to GND on the board.

VCC**Core Supply Voltage**

Supply voltage to the FPGA core, nominally 1.5 V. VCC is required for powering the JTAG state machine in addition to VJTAG. Even when a device is in bypass mode in a JTAG chain of interconnected devices, both VCC and VJTAG must remain powered to allow JTAG signals to pass through the device.

VCCIBx**I/O Supply Voltage**

Supply voltage to the bank's I/O output buffers and I/O logic. Bx is the I/O bank number. There are up to eight I/O banks on low power flash devices plus a dedicated VJTAG bank. Each bank can have a separate VCCI connection. All I/Os in a bank will run off the same VCCIBx supply. VCCI can be 1.5 V, 1.8 V, 2.5 V, or 3.3 V, nominal voltage. In general, unused I/O banks should have their corresponding VCCIX pins tied to GND. If an output pad is terminated to ground through any resistor and if the corresponding VCCIX is left floating, then the leakage current to ground is ~ 0uA. However, if an output pad is terminated to ground through any resistor and the corresponding VCCIX grounded, then the leakage current to ground is ~ 3 uA. For unused banks the aforementioned behavior is to be taken into account while deciding if it's better to float VCCIX of unused bank or tie it to GND.

VMVx**I/O Supply Voltage (quiet)**

Quiet supply voltage to the input buffers of each I/O bank. x is the bank number. Within the package, the VMV plane biases the input stage of the I/Os in the I/O banks. This minimizes the noise transfer within the package and improves input signal integrity. Each bank must have at least one VMV connection, and no VMV should be left unconnected. All I/Os in a bank run off the same VMVx supply. VMV is used to provide a quiet supply voltage to the input buffers of each I/O bank. VMVx can be 1.5 V, 1.8 V, 2.5 V, or 3.3 V, nominal voltage. Unused I/O banks should have their corresponding VMV pins tied to GND. VMV and VCCI should be at the same voltage within a given I/O bank. Used VMV pins must be connected to the corresponding VCCI pins of the same bank (i.e., VMV0 to VCCIB0, VMV1 to VCCIB1, etc.).

VCCPLA/B/C/D/E/F**PLL Supply Voltage**

Supply voltage to analog PLL, nominally 1.5 V.

When the PLLs are not used, the place-and-route tool automatically disables the unused PLLs to lower power consumption. The user should tie unused VCCPLx and VCOMPLx pins to ground. Microsemi recommends tying VCCPLx to VCC and using proper filtering circuits to decouple VCC noise from the PLLs. Refer to the PLL Power Supply Decoupling section of the "Clock Conditioning Circuits in Low Power Flash Devices and Mixed Signal FPGAs" chapter of the [ProASIC3E FPGA Fabric User's Guide](#) for a complete board solution for the PLL analog power supply and ground.

There are six VCCPLX pins on ProASIC3E devices.

VCOMPLA/B/C/D/E/F**PLL Ground**

Ground to analog PLL power supplies. When the PLLs are not used, the place-and-route tool automatically disables the unused PLLs to lower power consumption. The user should tie unused VCCPLx and VCOMPLx pins to ground.

There are six VCOMPL pins (PLL ground) on ProASIC3E devices.

VJTAG**JTAG Supply Voltage**

Low power flash devices have a separate bank for the dedicated JTAG pins. The JTAG pins can be run at any voltage from 1.5 V to 3.3 V (nominal). Isolating the JTAG power supply in a separate I/O bank gives greater flexibility in supply selection and simplifies power supply and PCB design. If the JTAG

interface is neither used nor planned for use, the VJTAG pin together with the TRST pin could be tied to GND. It should be noted that VCC is required to be powered for JTAG operation; VJTAG alone is insufficient. If a device is in a JTAG chain of interconnected boards, the board containing the device can be powered down, provided both VJTAG and VCC to the part remain powered; otherwise, JTAG signals will not be able to transition the device, even in bypass mode.

Microsemi recommends that VPUMP and VJTAG power supplies be kept separate with independent filtering capacitors rather than supplying them from a common rail.

VPUMP Programming Supply Voltage

For programming, VPUMP should be 3.3 V nominal. During normal device operation, VPUMP can be left floating or can be tied (pulled up) to any voltage between 0 V and the VPUMP maximum. Programming power supply voltage (VPUMP) range is listed in the datasheet.

When the VPUMP pin is tied to ground, it will shut off the charge pump circuitry, resulting in no sources of oscillation from the charge pump circuitry.

For proper programming, 0.01 μ F and 0.33 μ F capacitors (both rated at 16 V) are to be connected in parallel across VPUMP and GND, and positioned as close to the FPGA pins as possible.

Microsemi recommends that VPUMP and VJTAG power supplies be kept separate with independent filtering capacitors rather than supplying them from a common rail.

User-Defined Supply Pins

VREF I/O Voltage Reference

Reference voltage for I/O minibanks. VREF pins are configured by the user from regular I/Os, and any I/O in a bank, except JTAG I/Os, can be designated the voltage reference I/O. Only certain I/O standards require a voltage reference—HSTL (I) and (II), SSTL2 (I) and (II), SSTL3 (I) and (II), and GTL/GTL+. One VREF pin can support the number of I/Os available in its minibank.

User Pins

I/O User Input/Output

The I/O pin functions as an input, output, tristate, or bidirectional buffer. Input and output signal levels are compatible with the I/O standard selected.

During programming, I/Os become tristated and weakly pulled up to VCCI. With VCCI, VMV, and VCC supplies continuously powered up, when the device transitions from programming to operating mode, the I/Os are instantly configured to the desired user configuration.

Unused I/Os are configured as follows:

- Output buffer is disabled (with tristate value of high impedance)
- Input buffer is disabled (with tristate value of high impedance)
- Weak pull-up is programmed

GL Globals

GL I/Os have access to certain clock conditioning circuitry (and the PLL) and/or have direct access to the global network (spines). Additionally, the global I/Os can be used as regular I/Os, since they have identical capabilities. Unused GL pins are configured as inputs with pull-up resistors.

See more detailed descriptions of global I/O connectivity in the "Clock Conditioning Circuits in Low Power Flash Devices and Mixed Signal FPGAs" chapter of the *ProASIC3E FPGA Fabric User's Guide*. All inputs labeled GC/GF are direct inputs into the quadrant clocks. For example, if GAA0 is used for an input, GAA1 and GAA2 are no longer available for input to the quadrant globals. All inputs labeled GC/GF are direct inputs into the chip-level globals, and the rest are connected to the quadrant globals. The inputs to the global network are multiplexed, and only one input can be used as a global input.

Refer to the I/O Structure section of the *ProASIC3E FPGA Fabric User's Guide* for an explanation of the naming of global pins.

JTAG Pins

Low power flash devices have a separate bank for the dedicated JTAG pins. The JTAG pins can be run at any voltage from 1.5 V to 3.3 V (nominal). VCC must also be powered for the JTAG state machine to operate, even if the device is in bypass mode; VJTAG alone is insufficient. Both VJTAG and VCC to the part must be supplied to allow JTAG signals to transition the device. Isolating the JTAG power supply in a separate I/O bank gives greater flexibility in supply selection and simplifies power supply and PCB design. If the JTAG interface is neither used nor planned for use, the VJTAG pin together with the TRST pin could be tied to GND.

TCK **Test Clock**

Test clock input for JTAG boundary scan, ISP, and UJTAG. The TCK pin does not have an internal pull-up/down resistor. If JTAG is not used, Microsemi recommends tying off TCK to GND through a resistor placed close to the FPGA pin. This prevents JTAG operation in case TMS enters an undesired state.

Note that to operate at all VJTAG voltages, 500 Ω to 1 k Ω will satisfy the requirements. Refer to [Table 3-1](#) for more information.

Table 3-1 • Recommended Tie-Off Values for the TCK and TRST Pins

VJTAG	Tie-Off Resistance
VJTAG at 3.3 V	200 Ω to 1 k Ω
VJTAG at 2.5 V	200 Ω to 1 k Ω
VJTAG at 1.8 V	500 Ω to 1 k Ω
VJTAG at 1.5 V	500 Ω to 1 k Ω

Notes:

1. Equivalent parallel resistance if more than one device is on the JTAG chain
2. The TCK pin can be pulled up/down.
3. The TRST pin is pulled down.

TDI **Test Data Input**

Serial input for JTAG boundary scan, ISP, and UJTAG usage. There is an internal weak pull-up resistor on the TDI pin.

TDO **Test Data Output**

Serial output for JTAG boundary scan, ISP, and UJTAG usage.

TMS **Test Mode Select**

The TMS pin controls the use of the IEEE 1532 boundary scan pins (TCK, TDI, TDO, TRST). There is an internal weak pull-up resistor on the TMS pin.

TRST **Boundary Scan Reset Pin**

The TRST pin functions as an active-low input to asynchronously initialize (or reset) the boundary scan circuitry. There is an internal weak pull-up resistor on the TRST pin. If JTAG is not used, an external pull-down resistor could be included to ensure the test access port (TAP) is held in reset mode. The resistor values must be chosen from [Table 3-1](#) and must satisfy the parallel resistance value requirement. The values in [Table 3-1](#) correspond to the resistor recommended when a single device is used, and the equivalent parallel resistor when multiple devices are connected via a JTAG chain.

In critical applications, an upset in the JTAG circuit could allow entrance to an undesired JTAG state. In such cases, Microsemi recommends tying off TRST to GND through a resistor placed close to the FPGA pin.

Note that to operate at all VJTAG voltages, 500 Ω to 1 k Ω will satisfy the requirements.

Special Function Pins

NC

No Connect

This pin is not connected to circuitry within the device. These pins can be driven to any voltage or can be left floating with no effect on the operation of the device.

DC

Do Not Connect

This pin should not be connected to any signals on the PCB. These pins should be left unconnected.

Packaging

Semiconductor technology is constantly shrinking in size while growing in capability and functional integration. To enable next-generation silicon technologies, semiconductor packages have also evolved to provide improved performance and flexibility.

Microsemi consistently delivers packages that provide the necessary mechanical and environmental protection to ensure consistent reliability and performance. Microsemi IC packaging technology efficiently supports high-density FPGAs with large-pin-count Ball Grid Arrays (BGAs), but is also flexible enough to accommodate stringent form factor requirements for Chip Scale Packaging (CSP). In addition, Microsemi offers a variety of packages designed to meet your most demanding application and economic requirements for today's embedded and mobile systems.

Related Documents

User's Guides

ProASIC3E FPGA Fabric User's Guide

http://www.microsemi.com/document-portal/doc_download/130883-proasic3e-fpga-fabric-user-s-guide

Packaging

The following documents provide packaging information and device selection for low power flash devices.

Product Catalog

http://www.microsemi.com/soc/documents/ProdCat_PIB.pdf

Lists devices currently recommended for new designs and the packages available for each member of the family. Use this document or the datasheet tables to determine the best package for your design, and which package drawing to use.

Package Mechanical Drawings

http://www.microsemi.com/document-portal/doc_download/131095-package-mechanical-drawings

This document contains the package mechanical drawings for all packages currently or previously supplied by Microsemi. Use the bookmarks to navigate to the package mechanical drawings.

Additional packaging materials: <http://www.microsemi.com/products/fpga-soc/solutions>.

4 – Package Pin Assignments

PQ208

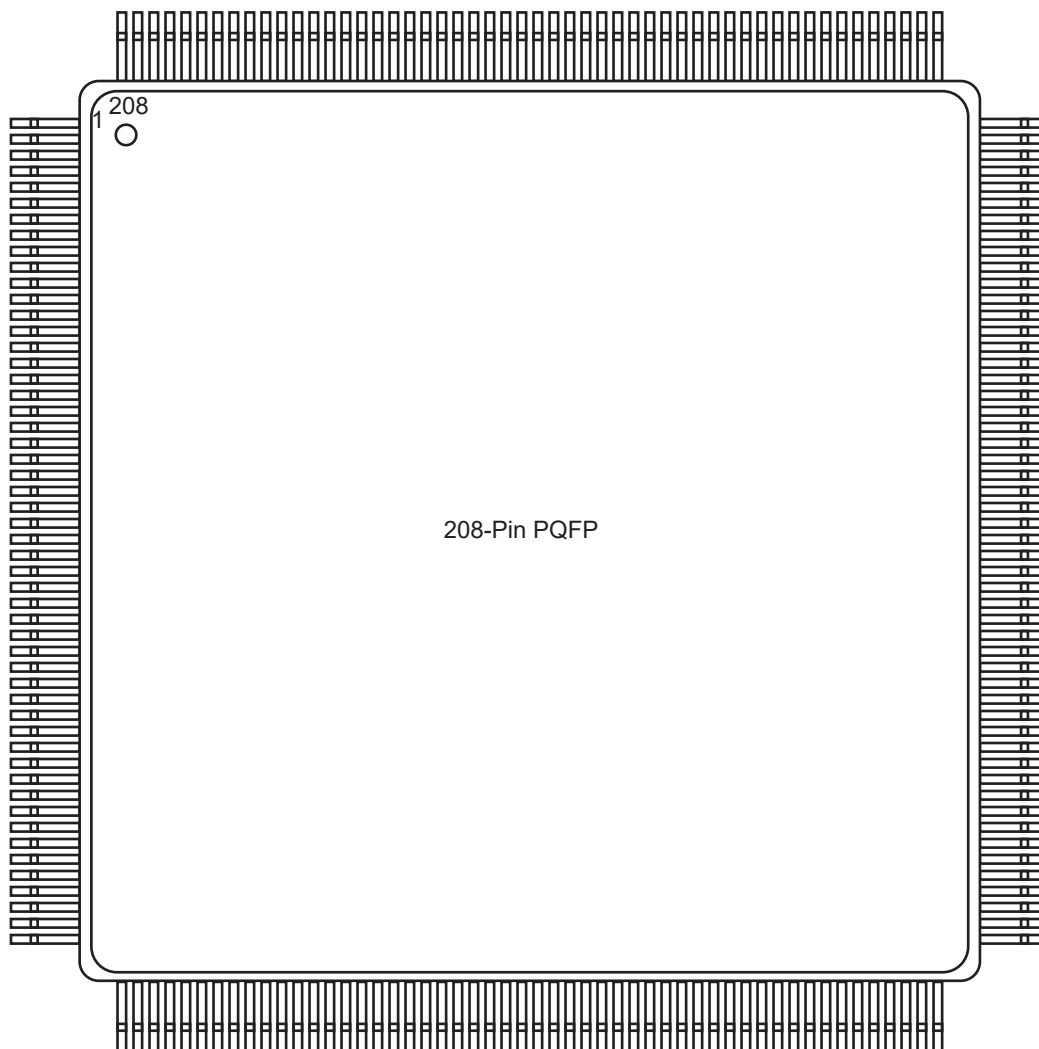

Note: This is the top view of the package.

Note

For Package Manufacturing and Environmental information, visit the Resource Center at <http://www.microsemi.com/products/fpga-soc/solutions>.

Package Pin Assignments

PQ208		PQ208		PQ208	
Pin Number	A3PE1500 Function	Pin Number	A3PE1500 Function	Pin Number	A3PE1500 Function
1	GND	37	IO184PDB6V2	73	IO145NDB5V1
2	GNDQ	38	IO184NDB6V2	74	IO145PDB5V1
3	VMV7	39	IO180PSB6V1	75	IO143NDB5V1
4	GAB2/IO220PSB7V3	40	VCCIB6	76	IO143PDB5V1
5	GAA2/IO221PDB7V3	41	GND	77	IO137NDB5V0
6	IO221NDB7V3	42	IO176PDB6V1	78	IO137PDB5V0
7	GAC2/IO219PDB7V3	43	IO176NDB6V1	79	IO135NDB5V0
8	IO219NDB7V3	44	GEC1/IO169PDB6V0	80	IO135PDB5V0
9	IO215PDB7V3	45	GEC0/IO169NDB6V0	81	GND
10	IO215NDB7V3	46	GEB1/IO168PPB6V0	82	IO131NDB4V2
11	IO212PDB7V2	47	GEA1/IO167PPB6V0	83	IO131PDB4V2
12	IO212NDB7V2	48	GEB0/IO168NPB6V0	84	IO129NDB4V2
13	IO208PDB7V2	49	GEA0/IO167NPB6V0	85	IO129PDB4V2
14	IO208NDB7V2	50	VMV6	86	IO127NDB4V2
15	IO204PSB7V1	51	GNDQ	87	IO127PDB4V2
16	VCC	52	GND	88	VCC
17	GND	53	VMV5	89	VCCIB4
18	VCCIB7	54	GNDQ	90	IO121NDB4V1
19	IO200PDB7V1	55	IO166NDB5V3	91	IO121PDB4V1
20	IO200NDB7V1	56	GEA2/IO166PDB5V3	92	IO119NDB4V1
21	IO196PSB7V0	57	IO165NDB5V3	93	IO119PDB4V1
22	GFC1/IO192PSB7V0	58	GEB2/IO165PDB5V3	94	IO113NDB4V0
23	GFB1/IO191PDB7V0	59	IO164NDB5V3	95	GDC2/IO113PDB4V0
24	GFB0/IO191NDB7V0	60	GEC2/IO164PDB5V3	96	IO112NDB4V0
25	VCOMPLF	61	IO163PSB5V3	97	GND
26	GFA0/IO190NPB6V2	62	VCCIB5	98	GDB2/IO112PDB4V0
27	VCCPLF	63	IO161PSB5V3	99	GDA2/IO111PSB4V0
28	GFA1/IO190PPB6V2	64	IO157NDB5V2	100	GNDQ
29	GND	65	GND	101	TCK
30	GFA2/IO189PDB6V2	66	IO157PDB5V2	102	TDI
31	IO189NDB6V2	67	IO153NDB5V2	103	TMS
32	GFB2/IO188PPB6V2	68	IO153PDB5V2	104	VMV4
33	GFC2/IO187PPB6V2	69	IO149NDB5V1	105	GND
34	IO188NPB6V2	70	IO149PDB5V1	106	VPUMP
35	IO187NPB6V2	71	VCC	107	GNDQ
36	VCC	72	VCCIB5	108	TDO

PQ208	
Pin Number	A3PE1500 Function
109	TRST
110	VJTAG
111	VMV3
112	GDA0/IO110NPB3V2
113	GDB0/IO109NPB3V2
114	GDA1/IO110PPB3V2
115	GDB1/IO109PPB3V2
116	GDC0/IO108NDB3V2
117	GDC1/IO108PDB3V2
118	IO105NDB3V2
119	IO105PDB3V2
120	IO101NDB3V1
121	IO101PDB3V1
122	GND
123	VCCIB3
124	GCC2/IO90PSB3V0
125	GCB2/IO89PSB3V0
126	NC
127	IO88NDB3V0
128	GCA2/IO88PDB3V0
129	GCA1/IO87PPB3V0
130	GND
131	VCCPLC
132	GCA0/IO87NPB3V0
133	VCOMPLC
134	GCB0/IO86NDB2V3
135	GCB1/IO86PDB2V3
136	GCC1/IO85PSB2V3
137	IO83NDB2V3
138	IO83PDB2V3
139	IO81PSB2V3
140	VCCIB2
141	GND
142	VCC
143	IO73NDB2V2
144	IO73PDB2V2

PQ208	
Pin Number	A3PE1500 Function
145	IO71NDB2V2
146	IO71PDB2V2
147	IO67NDB2V1
148	IO67PDB2V1
149	IO65NDB2V1
150	IO65PDB2V1
151	GBC2/IO60PSB2V0
152	GBA2/IO58PSB2V0
153	GBB2/IO59PSB2V0
154	VMV2
155	GNDQ
156	GND
157	VMV1
158	GNDQ
159	GBA1/IO57PDB1V3
160	GBA0/IO57NDB1V3
161	GBB1/IO56PDB1V3
162	GND
163	GBB0/IO56NDB1V3
164	GBC1/IO55PDB1V3
165	GBC0/IO55NDB1V3
166	IO51PDB1V2
167	IO51NDB1V2
168	IO47PDB1V1
169	IO47NDB1V1
170	VCCIB1
171	VCC
172	IO43PSB1V1
173	IO41PDB1V1
174	IO41NDB1V1
175	IO35PDB1V0
176	IO35NDB1V0
177	IO31PDB0V3
178	GND
179	IO31NDB0V3
180	IO29PDB0V3

PQ208	
Pin Number	A3PE1500 Function
181	IO29NDB0V3
182	IO27PDB0V3
183	IO27NDB0V3
184	IO23PDB0V2
185	IO23NDB0V2
186	VCCIB0
187	VCC
188	IO18PDB0V2
189	IO18NDB0V2
190	IO15PDB0V1
191	IO15NDB0V1
192	IO12PSB0V1
193	IO11PDB0V1
194	IO11NDB0V1
195	GND
196	IO08PDB0V1
197	IO08NDB0V1
198	IO05PDB0V0
199	IO05NDB0V0
200	VCCIB0
201	GAC1/IO02PDB0V0
202	GAC0/IO02NDB0V0
203	GAB1/IO01PDB0V0
204	GAB0/IO01NDB0V0
205	GAA1/IO00PDB0V0
206	GAA0/IO00NDB0V0
207	GNDQ
208	VMV0

Package Pin Assignments

PQ208		PQ208		PQ208	
Pin Number	A3PE3000 Function	Pin Number	A3PE3000 Function	Pin Number	A3PE3000 Function
1	GND	40	VCCIB6	79	IO194NDB5V0
2	GNDQ	41	GND	80	IO194PDB5V0
3	VMV7	42	IO244PDB6V1	81	GND
4	GAB2/IO308PSB7V4	43	IO244NDB6V1	82	IO184NDB4V3
5	GAA2/IO309PDB7V4	44	GEC1/IO236PDB6V0	83	IO184PDB4V3
6	IO309NDB7V4	45	GEC0/IO236NDB6V0	84	IO180NDB4V3
7	GAC2/IO307PDB7V4	46	GEB1/IO235PPB6V0	85	IO180PDB4V3
8	IO307NDB7V4	47	GEA1/IO234PPB6V0	86	IO176NDB4V2
9	IO303PDB7V3	48	GEB0/IO235NPB6V0	87	IO176PDB4V2
10	IO303NDB7V3	49	GEA0/IO234NPB6V0	88	VCC
11	IO299PDB7V3	50	VMV6	89	VCCIB4
12	IO299NDB7V3	51	GNDQ	90	IO170NDB4V2
13	IO295PDB7V2	52	GND	91	IO170PDB4V2
14	IO295NDB7V2	53	VMV5	92	IO166NDB4V1
15	IO291PSB7V2	54	GNDQ	93	IO166PDB4V1
16	VCC	55	IO233NDB5V4	94	IO156NDB4V0
17	GND	56	GEA2/IO233PDB5V4	95	GDC2/IO156PDB4V0
18	VCCIB7	57	IO232NDB5V4	96	IO154NPB4V0
19	IO285PDB7V1	58	GEB2/IO232PDB5V4	97	GND
20	IO285NDB7V1	59	IO231NDB5V4	98	GDB2/IO155PSB4V0
21	IO279PSB7V0	60	GEC2/IO231PDB5V4	99	GDA2/IO154PPB4V0
22	GFC1/IO275PSB7V0	61	IO230PSB5V4	100	GNDQ
23	GFB1/IO274PDB7V0	62	VCCIB5	101	TCK
24	GFB0/IO274NDB7V0	63	IO218NDB5V3	102	TDI
25	VCOMPLF	64	IO218PDB5V3	103	TMS
26	GFA0/IO273NPB6V4	65	GND	104	VMV4
27	VCCPLF	66	IO214PSB5V2	105	GND
28	GFA1/IO273PPB6V4	67	IO212NDB5V2	106	VPUMP
29	GND	68	IO212PDB5V2	107	GNDQ
30	GFA2/IO272PDB6V4	69	IO208NDB5V1	108	TDO
31	IO272NDB6V4	70	IO208PDB5V1	109	TRST
32	GFB2/IO271PPB6V4	71	VCC	110	VJTAG
33	GFC2/IO270PPB6V4	72	VCCIB5	111	VMV3
34	IO271NPB6V4	73	IO202NDB5V1	112	GDA0/IO153NPB3V4
35	IO270NPB6V4	74	IO202PDB5V1	113	GDB0/IO152NPB3V4
36	VCC	75	IO198NDB5V0	114	GDA1/IO153PPB3V4
37	IO252PDB6V2	76	IO198PDB5V0	115	GDB1/IO152PPB3V4
38	IO252NDB6V2	77	IO197NDB5V0	116	GDC0/IO151NDB3V4
39	IO248PSB6V1	78	IO197PDB5V0	117	GDC1/IO151PDB3V4

PQ208		PQ208		PQ208	
Pin Number	A3PE3000 Function	Pin Number	A3PE3000 Function	Pin Number	A3PE3000 Function
118	IO134NDB3V2	157	VMV1	196	IO11PDB0V1
119	IO134PDB3V2	158	GNDQ	197	IO11NDB0V1
120	IO132NDB3V2	159	GBA1/IO81PDB1V4	198	IO08PDB0V0
121	IO132PDB3V2	160	GBA0/IO81NDB1V4	199	IO08NDB0V0
122	GND	161	GBB1/IO80PDB1V4	200	VCCIB0
123	VCCIB3	162	GND	201	GAC1/IO02PDB0V0
124	GCC2/IO117PSB3V0	163	GBB0/IO80NDB1V4	202	GAC0/IO02NDB0V0
125	GCB2/IO116PSB3V0	164	GBC1/IO79PDB1V4	203	GAB1/IO01PDB0V0
126	NC	165	GBC0/IO79NDB1V4	204	GAB0/IO01NDB0V0
127	IO115NDB3V0	166	IO74PDB1V4	205	GAA1/IO00PDB0V0
128	GCA2/IO115PDB3V0	167	IO74NDB1V4	206	GAA0/IO00NDB0V0
129	GCA1/IO114PPB3V0	168	IO70PDB1V3	207	GNDQ
130	GND	169	IO70NDB1V3	208	VMV0
131	VCCPLC	170	VCCIB1		
132	GCA0/IO114NPB3V0	171	VCC		
133	VCOMPLC	172	IO56PSB1V1		
134	GCB0/IO113NDB2V3	173	IO55PDB1V1		
135	GCB1/IO113PDB2V3	174	IO55NDB1V1		
136	GCC1/IO112PSB2V3	175	IO54PDB1V1		
137	IO110NDB2V3	176	IO54NDB1V1		
138	IO110PDB2V3	177	IO40PDB0V4		
139	IO106PSB2V3	178	GND		
140	VCCIB2	179	IO40NDB0V4		
141	GND	180	IO37PDB0V4		
142	VCC	181	IO37NDB0V4		
143	IO99NDB2V2	182	IO35PDB0V4		
144	IO99PDB2V2	183	IO35NDB0V4		
145	IO96NDB2V1	184	IO32PDB0V3		
146	IO96PDB2V1	185	IO32NDB0V3		
147	IO91NDB2V1	186	VCCIB0		
148	IO91PDB2V1	187	VCC		
149	IO88NDB2V0	188	IO28PDB0V3		
150	IO88PDB2V0	189	IO28NDB0V3		
151	GBC2/IO84PSB2V0	190	IO24PDB0V2		
152	GBA2/IO82PSB2V0	191	IO24NDB0V2		
153	GBB2/IO83PSB2V0	192	IO21PSB0V2		
154	VMV2	193	IO16PDB0V1		
155	GNDQ	194	IO16NDB0V1		
156	GND	195	GND		

FG256

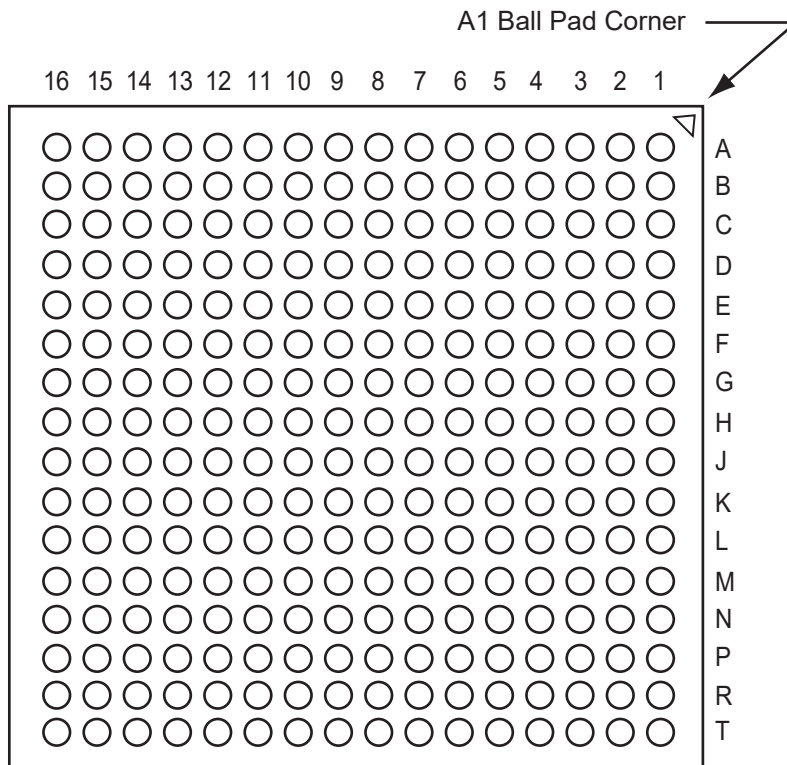

Note: This is the bottom view of the package.

Note

For Package Manufacturing and Environmental information, visit the Resource Center at <http://www.microsemi.com/products/fpga-soc/solutions>.

FG256	
Pin Number	A3PE600 Function
A1	GND
A2	GAA0/IO00NDB0V0
A3	GAA1/IO00PDB0V0
A4	GAB0/IO01NDB0V0
A5	IO05PDB0V0
A6	IO10PDB0V1
A7	IO12PDB0V2
A8	IO16NDB0V2
A9	IO23NDB1V0
A10	IO23PDB1V0
A11	IO28NDB1V1
A12	IO28PDB1V1
A13	GBB1/IO34PDB1V1
A14	GBA0/IO35NDB1V1
A15	GBA1/IO35PDB1V1
A16	GND
B1	GAB2/IO133PDB7V1
B2	GAA2/IO134PDB7V1
B3	GNDQ
B4	GAB1/IO01PDB0V0
B5	IO05NDB0V0
B6	IO10NDB0V1
B7	IO12NDB0V2
B8	IO16PDB0V2
B9	IO20NDB1V0
B10	IO24NDB1V0
B11	IO24PDB1V0
B12	GBC1/IO33PDB1V1
B13	GBB0/IO34NDB1V1
B14	GNDQ
B15	GBA2/IO36PDB2V0
B16	IO42NDB2V0
C1	IO133NDB7V1
C2	IO134NDB7V1
C3	VMV7
C4	VCCPLA

FG256	
Pin Number	A3PE600 Function
C5	GAC0/IO02NDB0V0
C6	GAC1/IO02PDB0V0
C7	IO15NDB0V2
C8	IO15PDB0V2
C9	IO20PDB1V0
C10	IO25NDB1V0
C11	IO27PDB1V0
C12	GBC0/IO33NDB1V1
C13	VCCPLB
C14	VMV2
C15	IO36NDB2V0
C16	IO42PDB2V0
D1	IO128PDB7V1
D2	IO129PDB7V1
D3	GAC2/IO132PDB7V1
D4	VCOMPLA
D5	GNDQ
D6	IO09NDB0V1
D7	IO09PDB0V1
D8	IO13PDB0V2
D9	IO21PDB1V0
D10	IO25PDB1V0
D11	IO27NDB1V0
D12	GNDQ
D13	VCOMPLB
D14	GBB2/IO37PDB2V0
D15	IO39PDB2V0
D16	IO39NDB2V0
E1	IO128NDB7V1
E2	IO129NDB7V1
E3	IO132NDB7V1
E4	IO130PDB7V1
E5	VMV0
E6	VCCIB0
E7	VCCIB0
E8	IO13NDB0V2

FG256	
Pin Number	A3PE600 Function
E9	IO21NDB1V0
E10	VCCIB1
E11	VCCIB1
E12	VMV1
E13	GBC2/IO38PDB2V0
E14	IO37NDB2V0
E15	IO41NDB2V0
E16	IO41PDB2V0
F1	IO124PDB7V0
F2	IO125PDB7V0
F3	IO126PDB7V0
F4	IO130NDB7V1
F5	VCCIB7
F6	GND
F7	VCC
F8	VCC
F9	VCC
F10	VCC
F11	GND
F12	VCCIB2
F13	IO38NDB2V0
F14	IO40NDB2V0
F15	IO40PDB2V0
F16	IO45PSB2V1
G1	IO124NDB7V0
G2	IO125NDB7V0
G3	IO126NDB7V0
G4	GFC1/IO120PPB7V0
G5	VCCIB7
G6	VCC
G7	GND
G8	GND
G9	GND
G10	GND
G11	VCC
G12	VCCIB2

Package Pin Assignments

FG256		FG256		FG256	
Pin Number	A3PE600 Function	Pin Number	A3PE600 Function	Pin Number	A3PE600 Function
G13	GCC1/IO50PPB2V1	K1	GFC2/IO115PSB6V1	M5	VMV5
G14	IO44NDB2V1	K2	IO113PPB6V1	M6	VCCIB5
G15	IO44PDB2V1	K3	IO112PDB6V1	M7	VCCIB5
G16	IO49NSB2V1	K4	IO112NDB6V1	M8	IO84NDB5V0
H1	GFB0/IO119NPB7V0	K5	VCCIB6	M9	IO84PDB5V0
H2	GFA0/IO118NDB6V1	K6	VCC	M10	VCCIB4
H3	GFB1/IO119PPB7V0	K7	GND	M11	VCCIB4
H4	VCOMPLF	K8	GND	M12	VMV3
H5	GFC0/IO120NPB7V0	K9	GND	M13	VCCPLD
H6	VCC	K10	GND	M14	GDB1/IO66PPB3V1
H7	GND	K11	VCC	M15	GDC1/IO65PDB3V1
H8	GND	K12	VCCIB3	M16	IO61NDB3V1
H9	GND	K13	IO54NPB3V0	N1	IO105PDB6V0
H10	GND	K14	IO57NPB3V0	N2	IO105NDB6V0
H11	VCC	K15	IO55NPB3V0	N3	GEC1/IO104PPB6V0
H12	GCC0/IO50NPB2V1	K16	IO57PPB3V0	N4	VCOMPLE
H13	GCB1/IO51PPB2V1	L1	IO113NPB6V1	N5	GNDQ
H14	GCA0/IO52NPB3V0	L2	IO109PPB6V0	N6	GEA2/IO101PPB5V2
H15	VCOMPLC	L3	IO108PDB6V0	N7	IO92NDB5V1
H16	GCB0/IO51NPB2V1	L4	IO108NDB6V0	N8	IO90NDB5V1
J1	GFA2/IO117PSB6V1	L5	VCCIB6	N9	IO82NDB5V0
J2	GFA1/IO118PDB6V1	L6	GND	N10	IO74NDB4V1
J3	VCCPLF	L7	VCC	N11	IO74PDB4V1
J4	IO116NDB6V1	L8	VCC	N12	GNDQ
J5	GFB2/IO116PDB6V1	L9	VCC	N13	VCOMPLD
J6	VCC	L10	VCC	N14	VJTAG
J7	GND	L11	GND	N15	GDC0/IO65NDB3V1
J8	GND	L12	VCCIB3	N16	GDA1/IO67PDB3V1
J9	GND	L13	GDB0/IO66NPB3V1	P1	GEB1/IO103PDB6V0
J10	GND	L14	IO60NDB3V1	P2	GEB0/IO103NDB6V0
J11	VCC	L15	IO60PDB3V1	P3	VMV6
J12	GCB2/IO54PPB3V0	L16	IO61PDB3V1	P4	VCCPLE
J13	GCA1/IO52PPB3V0	M1	IO109NPB6V0	P5	IO101NPB5V2
J14	GCC2/IO55PPB3V0	M2	IO106NDB6V0	P6	IO95PPB5V1
J15	VCCPLC	M3	IO106PDB6V0	P7	IO92PDB5V1
J16	GCA2/IO53PSB3V0	M4	GEC0/IO104NPB6V0	P8	IO90PDB5V1

FG256	
Pin Number	A3PE600 Function
P9	IO82PDB5V0
P10	IO76NDB4V1
P11	IO76PDB4V1
P12	VMV4
P13	TCK
P14	VPUMP
P15	TRST
P16	GDA0/IO67NDB3V1
R1	GEA1/IO102PDB6V0
R2	GEA0/IO102NDB6V0
R3	GNDQ
R4	GEC2/IO99PDB5V2
R5	IO95NPB5V1
R6	IO91NDB5V1
R7	IO91PDB5V1
R8	IO83NDB5V0
R9	IO83PDB5V0
R10	IO77NDB4V1
R11	IO77PDB4V1
R12	IO69NDB4V0
R13	GDB2/IO69PDB4V0
R14	TDI
R15	GNDQ
R16	TDO
T1	GND
T2	IO100NDB5V2
T3	GEB2/IO100PDB5V2
T4	IO99NDB5V2
T5	IO88NDB5V0
T6	IO88PDB5V0
T7	IO89NSB5V0
T8	IO80NSB4V1
T9	IO81NDB4V1
T10	IO81PDB4V1
T11	IO70NDB4V0
T12	GDC2/IO70PDB4V0

FG256	
Pin Number	A3PE600 Function
T13	IO68NDB4V0
T14	GDA2/IO68PDB4V0
T15	TMS
T16	GND

FG324

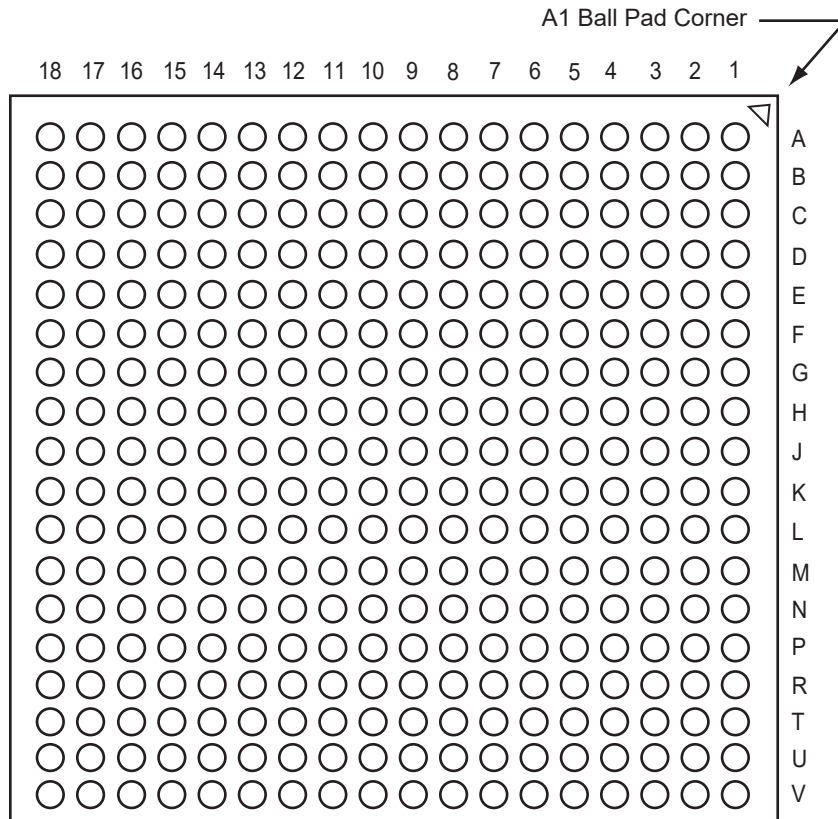

Note: This is the bottom view of the package.

Note

For Package Manufacturing and Environmental information, visit the Resource Center at <http://www.microsemi.com/products/fpga-soc/solutions>.

FG324	
Pin Number	A3PE3000 FBGA
A1	GND
A2	IO08NDB0V0
A3	IO08PDB0V0
A4	IO10NDB0V1
A5	IO10PDB0V1
A6	IO12PDB0V1
A7	GND
A8	IO32NDB0V3
A9	IO32PDB0V3
A10	IO42PPB1V0
A11	IO52NPB1V1
A12	GND
A13	IO66NDB1V3
A14	IO72NDB1V3
A15	IO72PDB1V3
A16	IO74NDB1V4
A17	IO74PDB1V4
A18	GND
B1	IO305PDB7V3
B2	GAB2/IO308PDB7V4
B3	GAA0/IO00NPB0V0
B4	VCCIB0
B5	GNDQ
B6	IO12NDB0V1
B7	IO18NDB0V2
B8	VCCIB0
B9	IO42NPB1V0
B10	IO44NDB1V0
B11	VCCIB1
B12	IO52PPB1V1
B13	IO66PDB1V3
B14	GNDQ
B15	VCCIB1
B16	GBA0/IO81NDB1V4
B17	GBA1/IO81PDB1V4
B18	IO88PDB2V0

FG324	
Pin Number	A3PE3000 FBGA
C1	IO305NDB7V3
C2	IO308NDB7V4
C3	GAA2/IO309PPB7V4
C4	GAA1/IO00PPB0V0
C5	VMV0
C6	IO14NDB0V1
C7	IO18PDB0V2
C8	IO40NDB0V4
C9	IO40PDB0V4
C10	IO44PDB1V0
C11	IO56NDB1V1
C12	IO64NDB1V2
C13	IO64PDB1V2
C14	VMV1
C15	GBC0/IO79NDB1V4
C16	GBC1/IO79PDB1V4
C17	GBB2/IO83PPB2V0
C18	IO88NDB2V0
D1	IO303PDB7V3
D2	VCCIB7
D3	GAC2/IO307PPB7V4
D4	IO309NPB7V4
D5	GAB1/IO01PPB0V0
D6	IO14PDB0V1
D7	IO24NDB0V2
D8	IO24PDB0V2
D9	IO28PDB0V3
D10	IO48NDB1V0
D11	IO56PDB1V1
D12	IO60PPB1V2
D13	GBB0/IO80NDB1V4
D14	GBB1/IO80PDB1V4
D15	GBA2/IO82PDB2V0
D16	IO83NPB2V0
D17	VCCIB2
D18	IO90PDB2V1

FG324	
Pin Number	A3PE3000 FBGA
E1	IO303NDB7V3
E2	GNDQ
E3	VMV7
E4	IO307NPB7V4
E5	VCCPLA
E6	GAB0/IO01NPB0V0
E7	VCCIB0
E8	GND
E9	IO28NDB0V3
E10	IO48PDB1V0
E11	GND
E12	VCCIB1
E13	IO60NPB1V2
E14	VCCPLB
E15	IO82NDB2V0
E16	VMV2
E17	GNDQ
E18	IO90NDB2V1
F1	IO299NDB7V3
F2	IO299PDB7V3
F3	IO295PDB7V2
F4	IO295NDB7V2
F5	VCOMPLA
F6	IO291PPB7V2
F7	GAC0/IO02NDB0V0
F8	GAC1/IO02PDB0V0
F9	IO26PDB0V3
F10	IO34PDB0V4
F11	IO58NDB1V2
F12	IO58PDB1V2
F13	IO94PPB2V1
F14	VCOMPLB
F15	GBC2/IO84PDB2V0
F16	IO84NDB2V0
F17	IO92NDB2V1
F18	IO92PDB2V1

Package Pin Assignments

FG324		FG324		FG324	
Pin Number	A3PE3000 FBGA	Pin Number	A3PE3000 FBGA	Pin Number	A3PE3000 FBGA
G1	GND	J1	IO267NDB6V4	L1	IO263NDB6V3
G2	IO287PDB7V1	J2	GFA0/IO273NDB6V4	L2	VCCIB6
G3	IO287NDB7V1	J3	VCOMPLF	L3	IO259PDB6V3
G4	IO283PPB7V1	J4	GFA2/IO272PDB6V4	L4	IO259NDB6V3
G5	VCCIB7	J5	GFB0/IO274NPB7V0	L5	GND
G6	IO279PDB7V0	J6	GFC0/IO275NDB7V0	L6	IO270NPB6V4
G7	IO291NPB7V2	J7	GFC1/IO275PDB7V0	L7	VCC
G8	VCC	J8	GND	L8	VCC
G9	IO26NDB0V3	J9	GND	L9	GND
G10	IO34NDB0V4	J10	GND	L10	GND
G11	VCC	J11	GND	L11	VCC
G12	IO94NPB2V1	J12	GCA2/IO115PDB3V0	L12	VCC
G13	IO98PDB2V2	J13	GCA1/IO114PDB3V0	L13	IO132PDB3V2
G14	VCCIB2	J14	GCA0/IO114NDB3V0	L14	GND
G15	GCC0/IO112NPB2V3	J15	GCB0/IO113NDB2V3	L15	IO117NDB3V0
G16	IO104PDB2V2	J16	VCOMPLC	L16	IO128NPB3V1
G17	IO104NDB2V2	J17	IO120NPB3V0	L17	VCCIB3
G18	GND	J18	IO108NDB2V3	L18	IO124PPB3V1
H1	IO267PDB6V4	K1	IO263PDB6V3	M1	GND
H2	VCCIB7	K2	GFA1/IO273PDB6V4	M2	IO255PDB6V2
H3	IO283NPB7V1	K3	VCCPLF	M3	IO255NDB6V2
H4	GFB1/IO274PPB7V0	K4	IO272NDB6V4	M4	IO251PPB6V2
H5	GND	K5	GFC2/IO270PPB6V4	M5	VCCIB6
H6	IO279NDB7V0	K6	GFB2/IO271PDB6V4	M6	GEB0/IO235NDB6V0
H7	VCC	K7	IO271NDB6V4	M7	GEB1/IO235PDB6V0
H8	VCC	K8	GND	M8	VCC
H9	GND	K9	GND	M9	IO192PPB4V4
H10	GND	K10	GND	M10	IO154NPB4V0
H11	VCC	K11	GND	M11	VCC
H12	VCC	K12	IO115NDB3V0	M12	GDA0/IO153NPB3V4
H13	IO98NDB2V2	K13	GCB2/IO116PDB3V0	M13	IO132NDB3V2
H14	GND	K14	IO116NDB3V0	M14	VCCIB3
H15	GCB1/IO113PDB2V3	K15	GCC2/IO117PDB3V0	M15	IO134NDB3V2
H16	GCC1/IO112PPB2V3	K16	VCCPLC	M16	IO134PDB3V2
H17	VCCIB2	K17	IO124NPB3V1	M17	IO128PPB3V1
H18	IO108PDB2V3	K18	IO120PPB3V0	M18	GND

FG324	
Pin Number	A3PE3000 FBGA
N1	IO247NDB6V1
N2	IO247PDB6V1
N3	IO251NPB6V2
N4	GEC0/IO236NDB6V0
N5	VCOMPLE
N6	IO212NDB5V2
N7	IO212PDB5V2
N8	IO192NPB4V4
N9	IO174PDB4V2
N10	IO170PDB4V2
N11	GDA2/IO154PPB4V0
N12	GDB2/IO155PPB4V0
N13	GDA1/IO153PPB3V4
N14	VCOMPLD
N15	GDB0/IO152NDB3V4
N16	GDB1/IO152PDB3V4
N17	IO138NDB3V3
N18	IO138PDB3V3
P1	IO245PDB6V1
P2	GNDQ
P3	VMV6
P4	GEC1/IO236PDB6V0
P5	VCCPLE
P6	IO214PDB5V2
P7	VCCIB5
P8	GND
P9	IO174NDB4V2
P10	IO170NDB4V2
P11	GND
P12	VCCIB4
P13	IO155NPB4V0
P14	VCCPLD
P15	VJTAG
P16	GDC0/IO151NDB3V4
P17	GDC1/IO151PDB3V4
P18	IO142PDB3V3

FG324	
Pin Number	A3PE3000 FBGA
R1	IO245NDB6V1
R2	VCCIB6
R3	GEA1/IO234PPB6V0
R4	IO232NDB5V4
R5	GEB2/IO232PDB5V4
R6	IO214NDB5V2
R7	IO202PDB5V1
R8	IO194PDB5V0
R9	IO186PDB4V4
R10	IO178PDB4V3
R11	IO168NSB4V1
R12	IO164PDB4V1
R13	GDC2/IO156PDB4V0
R14	TCK
R15	VPUMP
R16	TRST
R17	VCCIB3
R18	IO142NDB3V3
T1	IO241PDB6V0
T2	GEA0/IO234NPB6V0
T3	IO233NPB5V4
T4	IO231NPB5V4
T5	VMV5
T6	IO208NDB5V1
T7	IO202NDB5V1
T8	IO194NDB5V0
T9	IO186NDB4V4
T10	IO178NDB4V3
T11	IO166NPB4V1
T12	IO164NDB4V1
T13	IO156NDB4V0
T14	VMV4
T15	TDI
T16	GNDQ
T17	TDO
T18	IO146PDB3V4

FG324	
Pin Number	A3PE3000 FBGA
U1	IO241NDB6V0
U2	GEA2/IO233PPB5V4
U3	GEC2/IO231PPB5V4
U4	VCCIB5
U5	GNDQ
U6	IO208PDB5V1
U7	IO198PPB5V0
U8	VCCIB5
U9	IO182NPB4V3
U10	IO180NPB4V3
U11	VCCIB4
U12	IO166PPB4V1
U13	IO162PDB4V1
U14	GNDQ
U15	VCCIB4
U16	TMS
U17	VMV3
U18	IO146NDB3V4
V1	GND
V2	IO218NDB5V3
V3	IO218PDB5V3
V4	IO206NDB5V1
V5	IO206PDB5V1
V6	IO198NPB5V0
V7	GND
V8	IO190NDB4V4
V9	IO190PDB4V4
V10	IO182PPB4V3
V11	IO180PPB4V3
V12	GND
V13	IO162NDB4V1
V14	IO160NDB4V0
V15	IO160PDB4V0
V16	IO158NDB4V0
V17	IO158PDB4V0
V18	GND

FG484	
Pin Number	A3PE600 Function
A1	GND
A2	GND
A3	VCCIB0
A4	IO06NDB0V1
A5	IO06PDB0V1
A6	IO08NDB0V1
A7	IO08PDB0V1
A8	IO11PDB0V1
A9	IO17PDB0V2
A10	IO18NDB0V2
A11	IO18PDB0V2
A12	IO22PDB1V0
A13	IO26PDB1V0
A14	IO29NDB1V1
A15	IO29PDB1V1
A16	IO31NDB1V1
A17	IO31PDB1V1
A18	IO32NDB1V1
A19	NC
A20	VCCIB1
A21	GND
A22	GND
AA1	GND
AA2	VCCIB6
AA3	NC
AA4	IO98PDB5V2
AA5	IO96NDB5V2
AA6	IO96PDB5V2
AA7	IO86NDB5V0
AA8	IO86PDB5V0
AA9	IO85PDB5V0
AA10	IO85NDB5V0
AA11	IO78PPB4V1
AA12	IO79NDB4V1
AA13	IO79PDB4V1
AA14	NC

FG484	
Pin Number	A3PE600 Function
AA15	NC
AA16	IO71NDB4V0
AA17	IO71PDB4V0
AA18	NC
AA19	NC
AA20	NC
AA21	VCCIB3
AA22	GND
AB1	GND
AB2	GND
AB3	VCCIB5
AB4	IO97NDB5V2
AB5	IO97PDB5V2
AB6	IO93NDB5V1
AB7	IO93PDB5V1
AB8	IO87NDB5V0
AB9	IO87PDB5V0
AB10	NC
AB11	NC
AB12	IO75NDB4V1
AB13	IO75PDB4V1
AB14	IO72NDB4V0
AB15	IO72PDB4V0
AB16	IO73NDB4V0
AB17	IO73PDB4V0
AB18	NC
AB19	NC
AB20	VCCIB4
AB21	GND
AB22	GND
B1	GND
B2	VCCIB7
B3	NC
B4	IO03NDB0V0
B5	IO03PDB0V0
B6	IO07NDB0V1

FG484	
Pin Number	A3PE600 Function
B7	IO07PDB0V1
B8	IO11NDB0V1
B9	IO17NDB0V2
B10	IO14PDB0V2
B11	IO19PDB0V2
B12	IO22NDB1V0
B13	IO26NDB1V0
B14	NC
B15	NC
B16	IO30NDB1V1
B17	IO30PDB1V1
B18	IO32PDB1V1
B19	NC
B20	NC
B21	VCCIB2
B22	GND
C1	VCCIB7
C2	NC
C3	NC
C4	NC
C5	GND
C6	IO04NDB0V0
C7	IO04PDB0V0
C8	VCC
C9	VCC
C10	IO14NDB0V2
C11	IO19NDB0V2
C12	NC
C13	NC
C14	VCC
C15	VCC
C16	NC
C17	NC
C18	GND
C19	NC
C20	NC

Package Pin Assignments

FG484		FG484		FG484	
Pin Number	A3PE600 Function	Pin Number	A3PE600 Function	Pin Number	A3PE600 Function
C21	NC	E13	IO24NDB1V0	G5	IO129PDB7V1
C22	VCCIB2	E14	IO24PDB1V0	G6	GAC2/IO132PDB7V1
D1	NC	E15	GBC1/IO33PDB1V1	G7	VCOMPLA
D2	NC	E16	GBB0/IO34NDB1V1	G8	GNDQ
D3	NC	E17	GNDQ	G9	IO09NDB0V1
D4	GND	E18	GBA2/IO36PDB2V0	G10	IO09PDB0V1
D5	GAA0/IO00NDB0V0	E19	IO42NDB2V0	G11	IO13PDB0V2
D6	GAA1/IO00PDB0V0	E20	GND	G12	IO21PDB1V0
D7	GAB0/IO01NDB0V0	E21	NC	G13	IO25PDB1V0
D8	IO05PDB0V0	E22	NC	G14	IO27NDB1V0
D9	IO10PDB0V1	F1	NC	G15	GNDQ
D10	IO12PDB0V2	F2	IO131NDB7V1	G16	VCOMPLB
D11	IO16NDB0V2	F3	IO131PDB7V1	G17	GBB2/IO37PDB2V0
D12	IO23NDB1V0	F4	IO133NDB7V1	G18	IO39PDB2V0
D13	IO23PDB1V0	F5	IO134NDB7V1	G19	IO39NDB2V0
D14	IO28NDB1V1	F6	VMV7	G20	IO43PDB2V0
D15	IO28PDB1V1	F7	VCCPLA	G21	IO43NDB2V0
D16	GBB1/IO34PDB1V1	F8	GAC0/IO02NDB0V0	G22	NC
D17	GBA0/IO35NDB1V1	F9	GAC1/IO02PDB0V0	H1	NC
D18	GBA1/IO35PDB1V1	F10	IO15NDB0V2	H2	NC
D19	GND	F11	IO15PDB0V2	H3	VCC
D20	NC	F12	IO20PDB1V0	H4	IO128NDB7V1
D21	NC	F13	IO25NDB1V0	H5	IO129NDB7V1
D22	NC	F14	IO27PDB1V0	H6	IO132NDB7V1
E1	NC	F15	GBC0/IO33NDB1V1	H7	IO130PDB7V1
E2	NC	F16	VCCPLB	H8	VMV0
E3	GND	F17	VMV2	H9	VCCIB0
E4	GAB2/IO133PDB7V1	F18	IO36NDB2V0	H10	VCCIB0
E5	GAA2/IO134PDB7V1	F19	IO42PDB2V0	H11	IO13NDB0V2
E6	GNDQ	F20	NC	H12	IO21NDB1V0
E7	GAB1/IO01PDB0V0	F21	NC	H13	VCCIB1
E8	IO05NDB0V0	F22	NC	H14	VCCIB1
E9	IO10NDB0V1	G1	IO127NDB7V1	H15	VMV1
E10	IO12NDB0V2	G2	IO127PDB7V1	H16	GBC2/IO38PDB2V0
E11	IO16PDB0V2	G3	NC	H17	IO37NDB2V0
E12	IO20NDB1V0	G4	IO128PDB7V1	H18	IO41NDB2V0

FG484	
Pin Number	A3PE600 Function
H19	IO41PDB2V0
H20	VCC
H21	NC
H22	NC
J1	IO123NDB7V0
J2	IO123PDB7V0
J3	NC
J4	IO124PDB7V0
J5	IO125PDB7V0
J6	IO126PDB7V0
J7	IO130NDB7V1
J8	VCCIB7
J9	GND
J10	VCC
J11	VCC
J12	VCC
J13	VCC
J14	GND
J15	VCCIB2
J16	IO38NDB2V0
J17	IO40NDB2V0
J18	IO40PDB2V0
J19	IO45PPB2V1
J20	NC
J21	IO48PDB2V1
J22	IO46PDB2V1
K1	IO121NDB7V0
K2	IO121PDB7V0
K3	NC
K4	IO124NDB7V0
K5	IO125NDB7V0
K6	IO126NDB7V0
K7	GFC1/IO120PPB7V0
K8	VCCIB7
K9	VCC
K10	GND

FG484	
Pin Number	A3PE600 Function
K11	GND
K12	GND
K13	GND
K14	VCC
K15	VCCIB2
K16	GCC1/IO50PPB2V1
K17	IO44NDB2V1
K18	IO44PDB2V1
K19	IO49NPB2V1
K20	IO45NPB2V1
K21	IO48NDB2V1
K22	IO46NDB2V1
L1	NC
L2	IO122PDB7V0
L3	IO122NDB7V0
L4	GFB0/IO119NPB7V0
L5	GFA0/IO118NDB6V1
L6	GFB1/IO119PPB7V0
L7	VCOMPLF
L8	GFC0/IO120NPB7V0
L9	VCC
L10	GND
L11	GND
L12	GND
L13	GND
L14	VCC
L15	GCC0/IO50NPB2V1
L16	GCB1/IO51PPB2V1
L17	GCA0/IO52NPB3V0
L18	VCOMPLC
L19	GCB0/IO51NPB2V1
L20	IO49PPB2V1
L21	IO47NDB2V1
L22	IO47PDB2V1
M1	NC
M2	IO114NPB6V1

FG484	
Pin Number	A3PE600 Function
M3	IO117NDB6V1
M4	GFA2/IO117PDB6V1
M5	GFA1/IO118PDB6V1
M6	VCCPLF
M7	IO116NDB6V1
M8	GFB2/IO116PDB6V1
M9	VCC
M10	GND
M11	GND
M12	GND
M13	GND
M14	VCC
M15	GCB2/IO54PPB3V0
M16	GCA1/IO52PPB3V0
M17	GCC2/IO55PPB3V0
M18	VCCPLC
M19	GCA2/IO53PDB3V0
M20	IO53NDB3V0
M21	IO56PDB3V0
M22	NC
N1	IO114PPB6V1
N2	IO111NDB6V1
N3	NC
N4	GFC2/IO115PPB6V1
N5	IO113PPB6V1
N6	IO112PDB6V1
N7	IO112NDB6V1
N8	VCCIB6
N9	VCC
N10	GND
N11	GND
N12	GND
N13	GND
N14	VCC
N15	VCCIB3
N16	IO54NPB3V0

Package Pin Assignments

FG484		FG484		FG484	
Pin Number	A3PE600 Function	Pin Number	A3PE600 Function	Pin Number	A3PE600 Function
N17	IO57NPB3V0	R9	VCCIB5	U1	NC
N18	IO55NPB3V0	R10	VCCIB5	U2	IO107PDB6V0
N19	IO57PPB3V0	R11	IO84NDB5V0	U3	IO107NDB6V0
N20	NC	R12	IO84PDB5V0	U4	GEB1/IO103PDB6V0
N21	IO56NDB3V0	R13	VCCIB4	U5	GEB0/IO103NDB6V0
N22	IO58PDB3V0	R14	VCCIB4	U6	VMV6
P1	NC	R15	VMV3	U7	VCCPLE
P2	IO111PDB6V1	R16	VCCPLD	U8	IO101NPB5V2
P3	IO115NPB6V1	R17	GDB1/IO66PPB3V1	U9	IO95PPB5V1
P4	IO113NPB6V1	R18	GDC1/IO65PDB3V1	U10	IO92PDB5V1
P5	IO109PPB6V0	R19	IO61NDB3V1	U11	IO90PDB5V1
P6	IO108PDB6V0	R20	VCC	U12	IO82PDB5V0
P7	IO108NDB6V0	R21	IO59NDB3V0	U13	IO76NDB4V1
P8	VCCIB6	R22	IO62PDB3V1	U14	IO76PDB4V1
P9	GND	T1	NC	U15	VMV4
P10	VCC	T2	IO110NDB6V0	U16	TCK
P11	VCC	T3	NC	U17	VPUMP
P12	VCC	T4	IO105PDB6V0	U18	TRST
P13	VCC	T5	IO105NDB6V0	U19	GDA0/IO67NDB3V1
P14	GND	T6	GEC1/IO104PPB6V0	U20	NC
P15	VCCIB3	T7	VCOMPLE	U21	IO64NDB3V1
P16	GDB0/IO66NPB3V1	T8	GNDQ	U22	IO63PDB3V1
P17	IO60NDB3V1	T9	GEA2/IO101PPB5V2	V1	NC
P18	IO60PDB3V1	T10	IO92NDB5V1	V2	NC
P19	IO61PDB3V1	T11	IO90NDB5V1	V3	GND
P20	NC	T12	IO82NDB5V0	V4	GEA1/IO102PDB6V0
P21	IO59PDB3V0	T13	IO74NDB4V1	V5	GEA0/IO102NDB6V0
P22	IO58NDB3V0	T14	IO74PDB4V1	V6	GNDQ
R1	NC	T15	GNDQ	V7	GEC2/IO99PDB5V2
R2	IO110PDB6V0	T16	VCOMPLD	V8	IO95NPB5V1
R3	VCC	T17	VJTAG	V9	IO91NDB5V1
R4	IO109NPB6V0	T18	GDC0/IO65NDB3V1	V10	IO91PDB5V1
R5	IO106NDB6V0	T19	GDA1/IO67PDB3V1	V11	IO83NDB5V0
R6	IO106PDB6V0	T20	NC	V12	IO83PDB5V0
R7	GEC0/IO104NPB6V0	T21	IO64PDB3V1	V13	IO77NDB4V1
R8	VMV5	T22	IO62NDB3V1	V14	IO77PDB4V1

FG484	
Pin Number	A3PE600 Function
V15	IO69NDB4V0
V16	GDB2/IO69PDB4V0
V17	TDI
V18	GNDQ
V19	TDO
V20	GND
V21	NC
V22	IO63NDB3V1
W1	NC
W2	NC
W3	NC
W4	GND
W5	IO100NDB5V2
W6	GEB2/IO100PDB5V2
W7	IO99NDB5V2
W8	IO88NDB5V0
W9	IO88PDB5V0
W10	IO89NDB5V0
W11	IO80NDB4V1
W12	IO81NDB4V1
W13	IO81PDB4V1
W14	IO70NDB4V0
W15	GDC2/IO70PDB4V0
W16	IO68NDB4V0
W17	GDA2/IO68PDB4V0
W18	TMS
W19	GND
W20	NC
W21	NC
W22	NC
Y1	VCCIB6
Y2	NC
Y3	NC
Y4	IO98NDB5V2
Y5	GND
Y6	IO94NDB5V1

FG484	
Pin Number	A3PE600 Function
Y7	IO94PDB5V1
Y8	VCC
Y9	VCC
Y10	IO89PDB5V0
Y11	IO80PDB4V1
Y12	IO78NPB4V1
Y13	NC
Y14	VCC
Y15	VCC
Y16	NC
Y17	NC
Y18	GND
Y19	NC
Y20	NC
Y21	NC
Y22	VCCIB3

Package Pin Assignments

FG484		FG484		FG484	
Pin Number	A3PE1500 Function	Pin Number	A3PE1500 Function	Pin Number	A3PE1500 Function
A1	GND	AA15	NC	B7	IO10PDB0V1
A2	GND	AA16	IO117NDB4V0	B8	IO15NDB0V1
A3	VCCIB0	AA17	IO117PDB4V0	B9	IO17NDB0V2
A4	IO05NDB0V0	AA18	IO115NDB4V0	B10	IO20PDB0V2
A5	IO05PDB0V0	AA19	IO115PDB4V0	B11	IO29PDB0V3
A6	IO11NDB0V1	AA20	NC	B12	IO32NDB1V0
A7	IO11PDB0V1	AA21	VCCIB3	B13	IO43NDB1V1
A8	IO15PDB0V1	AA22	GND	B14	NC
A9	IO17PDB0V2	AB1	GND	B15	NC
A10	IO27NDB0V3	AB2	GND	B16	IO53NDB1V2
A11	IO27PDB0V3	AB3	VCCIB5	B17	IO53PDB1V2
A12	IO32PDB1V0	AB4	IO159NDB5V3	B18	IO54PDB1V3
A13	IO43PDB1V1	AB5	IO159PDB5V3	B19	NC
A14	IO47NDB1V1	AB6	IO149NDB5V1	B20	NC
A15	IO47PDB1V1	AB7	IO149PDB5V1	B21	VCCIB2
A16	IO51NDB1V2	AB8	IO138NDB5V0	B22	GND
A17	IO51PDB1V2	AB9	IO138PDB5V0	C1	VCCIB7
A18	IO54NDB1V3	AB10	NC	C2	NC
A19	NC	AB11	NC	C3	NC
A20	VCCIB1	AB12	IO127NDB4V2	C4	NC
A21	GND	AB13	IO127PDB4V2	C5	GND
A22	GND	AB14	IO125NDB4V1	C6	IO07NDB0V0
AA1	GND	AB15	IO125PDB4V1	C7	IO07PDB0V0
AA2	VCCIB6	AB16	IO122NDB4V1	C8	VCC
AA3	NC	AB17	IO122PDB4V1	C9	VCC
AA4	IO161PDB5V3	AB18	NC	C10	IO20NDB0V2
AA5	IO155NDB5V2	AB19	NC	C11	IO29NDB0V3
AA6	IO155PDB5V2	AB20	VCCIB4	C12	NC
AA7	IO154NDB5V2	AB21	GND	C13	NC
AA8	IO154PDB5V2	AB22	GND	C14	VCC
AA9	IO143PDB5V1	B1	GND	C15	VCC
AA10	IO143NDB5V1	B2	VCCIB7	C16	NC
AA11	IO131PPB4V2	B3	NC	C17	NC
AA12	IO129NDB4V2	B4	IO03NDB0V0	C18	GND
AA13	IO129PDB4V2	B5	IO03PDB0V0	C19	NC
AA14	NC	B6	IO10NDB0V1	C20	NC

FG484	
Pin Number	A3PE1500 Function
C21	NC
C22	VCCIB2
D1	NC
D2	NC
D3	NC
D4	GND
D5	GAA0/IO00NDB0V0
D6	GAA1/IO00PDB0V0
D7	GAB0/IO01NDB0V0
D8	IO09PDB0V1
D9	IO13PDB0V1
D10	IO21PDB0V2
D11	IO31NDB0V3
D12	IO37NDB1V0
D13	IO37PDB1V0
D14	IO49NDB1V2
D15	IO49PDB1V2
D16	GBB1/IO56PDB1V3
D17	GBA0/IO57NDB1V3
D18	GBA1/IO57PDB1V3
D19	GND
D20	NC
D21	IO69PDB2V1
D22	NC
E1	NC
E2	IO218PPB7V3
E3	GND
E4	GAB2/IO220PDB7V3
E5	GAA2/IO221PDB7V3
E6	GNDQ
E7	GAB1/IO01PDB0V0
E8	IO09NDB0V1
E9	IO13NDB0V1
E10	IO21NDB0V2
E11	IO31PDB0V3
E12	IO35NDB1V0

FG484	
Pin Number	A3PE1500 Function
E13	IO41NDB1V1
E14	IO41PDB1V1
E15	GBC1/IO55PDB1V3
E16	GBB0/IO56NDB1V3
E17	GNDQ
E18	GBA2/IO58PDB2V0
E19	IO63NDB2V0
E20	GND
E21	IO69NDB2V1
E22	NC
F1	IO218NPB7V3
F2	IO216NDB7V3
F3	IO216PDB7V3
F4	IO220NDB7V3
F5	IO221NDB7V3
F6	VMV7
F7	VCCPLA
F8	GAC0/IO02NDB0V0
F9	GAC1/IO02PDB0V0
F10	IO23NDB0V2
F11	IO23PDB0V2
F12	IO35PDB1V0
F13	IO39NDB1V0
F14	IO45PDB1V1
F15	GBC0/IO55NDB1V3
F16	VCCPLB
F17	VMV2
F18	IO58NDB2V0
F19	IO63PDB2V0
F20	NC
F21	NC
F22	NC
G1	IO211NDB7V2
G2	IO211PDB7V2
G3	NC
G4	IO214PDB7V3

FG484	
Pin Number	A3PE1500 Function
G5	IO217PDB7V3
G6	GAC2/IO219PDB7V3
G7	VCOMPLA
G8	GNDQ
G9	IO19NDB0V2
G10	IO19PDB0V2
G11	IO25PDB0V3
G12	IO33PDB1V0
G13	IO39PDB1V0
G14	IO45NDB1V1
G15	GNDQ
G16	VCOMPLB
G17	GBB2/IO59PDB2V0
G18	IO62PDB2V0
G19	IO62NDB2V0
G20	IO71PDB2V2
G21	IO71NDB2V2
G22	NC
H1	IO209PSB7V2
H2	NC
H3	VCC
H4	IO214NDB7V3
H5	IO217NDB7V3
H6	IO219NDB7V3
H7	IO215PDB7V3
H8	VMV0
H9	VCCIB0
H10	VCCIB0
H11	IO25NDB0V3
H12	IO33NDB1V0
H13	VCCIB1
H14	VCCIB1
H15	VMV1
H16	GBC2/IO60PDB2V0
H17	IO59NDB2V0
H18	IO67NDB2V1

Package Pin Assignments

FG484		FG484		FG484	
Pin Number	A3PE1500 Function	Pin Number	A3PE1500 Function	Pin Number	A3PE1500 Function
H19	IO67PDB2V1	K11	GND	M3	IO189NDB6V2
H20	VCC	K12	GND	M4	GFA2/IO189PDB6V2
H21	VMV2	K13	GND	M5	GFA1/IO190PDB6V2
H22	IO74PSB2V2	K14	VCC	M6	VCCPLF
J1	IO212NDB7V2	K15	VCCIB2	M7	IO188NDB6V2
J2	IO212PDB7V2	K16	GCC1/IO85PPB2V3	M8	GFB2/IO188PDB6V2
J3	VMV7	K17	IO73NDB2V2	M9	VCC
J4	IO206PDB7V1	K18	IO73PDB2V2	M10	GND
J5	IO204PDB7V1	K19	IO81NPB2V3	M11	GND
J6	IO210PDB7V2	K20	IO75NPB2V2	M12	GND
J7	IO215NDB7V3	K21	IO77NDB2V2	M13	GND
J8	VCCIB7	K22	IO79NDB2V3	M14	VCC
J9	GND	L1	NC	M15	GCB2/IO89PPB3V0
J10	VCC	L2	IO196PDB7V0	M16	GCA1/IO87PPB3V0
J11	VCC	L3	IO196NDB7V0	M17	GCC2/IO90PPB3V0
J12	VCC	L4	GFB0/IO191NPB7V0	M18	VCCPLC
J13	VCC	L5	GFA0/IO190NDB6V2	M19	GCA2/IO88PDB3V0
J14	GND	L6	GFB1/IO191PPB7V0	M20	IO88NDB3V0
J15	VCCIB2	L7	VCOMPLF	M21	IO93PDB3V0
J16	IO60NDB2V0	L8	GFC0/IO192NPB7V0	M22	NC
J17	IO65NDB2V1	L9	VCC	N1	IO185PPB6V2
J18	IO65PDB2V1	L10	GND	N2	IO183NDB6V2
J19	IO75PPB2V2	L11	GND	N3	VMV6
J20	GNDQ	L12	GND	N4	GFC2/IO187PPB6V2
J21	IO77PDB2V2	L13	GND	N5	IO184PPB6V2
J22	IO79PDB2V3	L14	VCC	N6	IO186PDB6V2
K1	IO200NDB7V1	L15	GCC0/IO85NPB2V3	N7	IO186NDB6V2
K2	IO200PDB7V1	L16	GCB1/IO86PPB2V3	N8	VCCIB6
K3	GNDQ	L17	GCA0/IO87NPB3V0	N9	VCC
K4	IO206NDB7V1	L18	VCOMPLC	N10	GND
K5	IO204NDB7V1	L19	GCB0/IO86NPB2V3	N11	GND
K6	IO210NDB7V2	L20	IO81PPB2V3	N12	GND
K7	GFC1/IO192PPB7V0	L21	IO83NDB2V3	N13	GND
K8	VCCIB7	L22	IO83PDB2V3	N14	VCC
K9	VCC	M1	GNDQ	N15	VCCIB3
K10	GND	M2	IO185NPB6V2	N16	IO89NPB3V0

FG484	
Pin Number	A3PE1500 Function
N17	IO91NPB3V0
N18	IO90NPB3V0
N19	IO91PPB3V0
N20	GNDQ
N21	IO93NDB3V0
N22	IO95PDB3V1
P1	NC
P2	IO183PDB6V2
P3	IO187NPB6V2
P4	IO184NPB6V2
P5	IO176PPB6V1
P6	IO182PDB6V1
P7	IO182NDB6V1
P8	VCCIB6
P9	GND
P10	VCC
P11	VCC
P12	VCC
P13	VCC
P14	GND
P15	VCCIB3
P16	GDB0/IO109NPB3V2
P17	IO97NDB3V1
P18	IO97PDB3V1
P19	IO99PDB3V1
P20	VMV3
P21	IO98PDB3V1
P22	IO95NDB3V1
R1	NC
R2	IO177PDB6V1
R3	VCC
R4	IO176NPB6V1
R5	IO174NDB6V0
R6	IO174PDB6V0
R7	GEC0/IO169NPB6V0
R8	VMV5

FG484	
Pin Number	A3PE1500 Function
R9	VCCIB5
R10	VCCIB5
R11	IO135NDB5V0
R12	IO135PDB5V0
R13	VCCIB4
R14	VCCIB4
R15	VMV3
R16	VCCPLD
R17	GDB1/IO109PPB3V2
R18	GDC1/IO108PDB3V2
R19	IO99NDB3V1
R20	VCC
R21	IO98NDB3V1
R22	IO101PDB3V1
T1	NC
T2	IO177NDB6V1
T3	NC
T4	IO171PDB6V0
T5	IO171NDB6V0
T6	GEC1/IO169PPB6V0
T7	VCOMPLE
T8	GNDQ
T9	GEA2/IO166PPB5V3
T10	IO145NDB5V1
T11	IO141NDB5V0
T12	IO139NDB5V0
T13	IO119NDB4V1
T14	IO119PDB4V1
T15	GNDQ
T16	VCOMPLD
T17	VJTAG
T18	GDC0/IO108NDB3V2
T19	GDA1/IO110PDB3V2
T20	NC
T21	IO103PDB3V2
T22	IO101NDB3V1

FG484	
Pin Number	A3PE1500 Function
U1	IO175PPB6V1
U2	IO173PDB6V0
U3	IO173NDB6V0
U4	GEB1/IO168PDB6V0
U5	GEB0/IO168NDB6V0
U6	VMV6
U7	VCCPLE
U8	IO166NPB5V3
U9	IO157PPB5V2
U10	IO145PDB5V1
U11	IO141PDB5V0
U12	IO139PDB5V0
U13	IO121NDB4V1
U14	IO121PDB4V1
U15	VMV4
U16	TCK
U17	VPUMP
U18	TRST
U19	GDA0/IO110NDB3V2
U20	NC
U21	IO103NDB3V2
U22	IO105PDB3V2
V1	NC
V2	IO175NPB6V1
V3	GND
V4	GEA1/IO167PDB6V0
V5	GEA0/IO167NDB6V0
V6	GNDQ
V7	GEC2/IO164PDB5V3
V8	IO157NPB5V2
V9	IO151NDB5V2
V10	IO151PDB5V2
V11	IO137NDB5V0
V12	IO137PDB5V0
V13	IO123NDB4V1
V14	IO123PDB4V1

Package Pin Assignments

FG484		FG484	
Pin Number	A3PE1500 Function	Pin Number	A3PE1500 Function
V15	IO112NDB4V0	Y7	IO163PDB5V3
V16	GDB2/IO112PDB4V0	Y8	VCC
V17	TDI	Y9	VCC
V18	GNDQ	Y10	IO147PDB5V1
V19	TDO	Y11	IO133PDB4V2
V20	GND	Y12	IO131NPB4V2
V21	NC	Y13	NC
V22	IO105NDB3V2	Y14	VCC
W1	NC	Y15	VCC
W2	NC	Y16	NC
W3	NC	Y17	NC
W4	GND	Y18	GND
W5	IO165NDB5V3	Y19	NC
W6	GEB2/IO165PDB5V3	Y20	NC
W7	IO164NDB5V3	Y21	NC
W8	IO153NDB5V2	Y22	VCCIB3
W9	IO153PDB5V2		
W10	IO147NDB5V1		
W11	IO133NDB4V2		
W12	IO130NDB4V2		
W13	IO130PDB4V2		
W14	IO113NDB4V0		
W15	GDC2/IO113PDB4V0		
W16	IO111NDB4V0		
W17	GDA2/IO111PDB4V0		
W18	TMS		
W19	GND		
W20	NC		
W21	NC		
W22	NC		
Y1	VCCIB6		
Y2	NC		
Y3	NC		
Y4	IO161NDB5V3		
Y5	GND		
Y6	IO163NDB5V3		

FG484		FG484		FG484	
Pin Number	A3PE3000 Function	Pin Number	A3PE3000 Function	Pin Number	A3PE3000 Function
A1	GND	AA15	IO170PDB4V2	B7	IO14PDB0V1
A2	GND	AA16	IO166NDB4V1	B8	IO18NDB0V2
A3	VCCIB0	AA17	IO166PDB4V1	B9	IO24NDB0V2
A4	IO10NDB0V1	AA18	IO160NDB4V0	B10	IO34PDB0V4
A5	IO10PDB0V1	AA19	IO160PDB4V0	B11	IO40PDB0V4
A6	IO16NDB0V1	AA20	IO158NPB4V0	B12	IO46NDB1V0
A7	IO16PDB0V1	AA21	VCCIB3	B13	IO54NDB1V1
A8	IO18PDB0V2	AA22	GND	B14	IO62NDB1V2
A9	IO24PDB0V2	AB1	GND	B15	IO62PDB1V2
A10	IO28NDB0V3	AB2	GND	B16	IO68NDB1V3
A11	IO28PDB0V3	AB3	VCCIB5	B17	IO68PDB1V3
A12	IO46PDB1V0	AB4	IO216NDB5V2	B18	IO72PDB1V3
A13	IO54PDB1V1	AB5	IO216PDB5V2	B19	IO74PDB1V4
A14	IO56NDB1V1	AB6	IO210NDB5V2	B20	IO76NPB1V4
A15	IO56PDB1V1	AB7	IO210PDB5V2	B21	VCCIB2
A16	IO64NDB1V2	AB8	IO208NDB5V1	B22	GND
A17	IO64PDB1V2	AB9	IO208PDB5V1	C1	VCCIB7
A18	IO72NDB1V3	AB10	IO197NDB5V0	C2	IO303PDB7V3
A19	IO74NDB1V4	AB11	IO197PDB5V0	C3	IO305PDB7V3
A20	VCCIB1	AB12	IO174NDB4V2	C4	IO06NPB0V0
A21	GND	AB13	IO174PDB4V2	C5	GND
A22	GND	AB14	IO172NDB4V2	C6	IO12NDB0V1
AA1	GND	AB15	IO172PDB4V2	C7	IO12PDB0V1
AA2	VCCIB6	AB16	IO168NDB4V1	C8	VCC
AA3	IO228PDB5V4	AB17	IO168PDB4V1	C9	VCC
AA4	IO224PDB5V3	AB18	IO162NDB4V1	C10	IO34NDB0V4
AA5	IO218NDB5V3	AB19	IO162PDB4V1	C11	IO40NDB0V4
AA6	IO218PDB5V3	AB20	VCCIB4	C12	IO48NDB1V0
AA7	IO212NDB5V2	AB21	GND	C13	IO48PDB1V0
AA8	IO212PDB5V2	AB22	GND	C14	VCC
AA9	IO198PDB5V0	B1	GND	C15	VCC
AA10	IO198NDB5V0	B2	VCCIB7	C16	IO70NDB1V3
AA11	IO188PPB4V4	B3	IO06PPB0V0	C17	IO70PDB1V3
AA12	IO180NDB4V3	B4	IO08NDB0V0	C18	GND
AA13	IO180PDB4V3	B5	IO08PDB0V0	C19	IO76PPB1V4
AA14	IO170NDB4V2	B6	IO14NDB0V1	C20	IO88NDB2V0

Package Pin Assignments

FG484		FG484		FG484	
Pin Number	A3PE3000 Function	Pin Number	A3PE3000 Function	Pin Number	A3PE3000 Function
C21	IO94PPB2V1	E13	IO58NDB1V2	G5	IO297PDB7V2
C22	VCCIB2	E14	IO58PDB1V2	G6	GAC2/IO307PDB7V4
D1	IO293PDB7V2	E15	GBC1/IO79PDB1V4	G7	VCOMPLA
D2	IO303NDB7V3	E16	GBB0/IO80NDB1V4	G8	GNDQ
D3	IO305NDB7V3	E17	GNDQ	G9	IO26NDB0V3
D4	GND	E18	GBA2/IO82PDB2V0	G10	IO26PDB0V3
D5	GAA0/IO00NDB0V0	E19	IO86NDB2V0	G11	IO36PDB0V4
D6	GAA1/IO00PDB0V0	E20	GND	G12	IO42PDB1V0
D7	GAB0/IO01NDB0V0	E21	IO90NDB2V1	G13	IO50PDB1V1
D8	IO20PDB0V2	E22	IO98PDB2V2	G14	IO60NDB1V2
D9	IO22PDB0V2	F1	IO299NPB7V3	G15	GNDQ
D10	IO30PDB0V3	F2	IO301NDB7V3	G16	VCOMPLB
D11	IO38NDB0V4	F3	IO301PDB7V3	G17	GBB2/IO83PDB2V0
D12	IO52NDB1V1	F4	IO308NDB7V4	G18	IO92PDB2V1
D13	IO52PDB1V1	F5	IO309NDB7V4	G19	IO92NDB2V1
D14	IO66NDB1V3	F6	VMV7	G20	IO102PDB2V2
D15	IO66PDB1V3	F7	VCCPLA	G21	IO102NDB2V2
D16	GBB1/IO80PDB1V4	F8	GAC0/IO02NDB0V0	G22	IO105NDB2V2
D17	GBA0/IO81NDB1V4	F9	GAC1/IO02PDB0V0	H1	IO286PSB7V1
D18	GBA1/IO81PDB1V4	F10	IO32NDB0V3	H2	IO291NPB7V2
D19	GND	F11	IO32PDB0V3	H3	VCC
D20	IO88PDB2V0	F12	IO44PDB1V0	H4	IO295NDB7V2
D21	IO90PDB2V1	F13	IO50NDB1V1	H5	IO297NDB7V2
D22	IO94NPB2V1	F14	IO60PDB1V2	H6	IO307NDB7V4
E1	IO293NDB7V2	F15	GBC0/IO79NDB1V4	H7	IO287PDB7V1
E2	IO299PPB7V3	F16	VCCPLB	H8	VMV0
E3	GND	F17	VMV2	H9	VCCIB0
E4	GAB2/IO308PDB7V4	F18	IO82NDB2V0	H10	VCCIB0
E5	GAA2/IO309PDB7V4	F19	IO86PDB2V0	H11	IO36NDB0V4
E6	GNDQ	F20	IO96PDB2V1	H12	IO42NDB1V0
E7	GAB1/IO01PDB0V0	F21	IO96NDB2V1	H13	VCCIB1
E8	IO20NDB0V2	F22	IO98NDB2V2	H14	VCCIB1
E9	IO22NDB0V2	G1	IO289NDB7V1	H15	VMV1
E10	IO30NDB0V3	G2	IO289PDB7V1	H16	GBC2/IO84PDB2V0
E11	IO38PDB0V4	G3	IO291PPB7V2	H17	IO83NDB2V0
E12	IO44NDB1V0	G4	IO295PDB7V2	H18	IO100NDB2V2

FG484		FG484		FG484	
Pin Number	A3PE3000 Function	Pin Number	A3PE3000 Function	Pin Number	A3PE3000 Function
H19	IO100PDB2V2	K11	GND	M3	IO272NDB6V4
H20	VCC	K12	GND	M4	GFA2/IO272PDB6V4
H21	VMV2	K13	GND	M5	GFA1/IO273PDB6V4
H22	IO105PDB2V2	K14	VCC	M6	VCCPLF
J1	IO285NDB7V1	K15	VCCIB2	M7	IO271NDB6V4
J2	IO285PDB7V1	K16	GCC1/IO112PPB2V3	M8	GFB2/IO271PDB6V4
J3	VMV7	K17	IO108NDB2V3	M9	VCC
J4	IO279PDB7V0	K18	IO108PDB2V3	M10	GND
J5	IO283PDB7V1	K19	IO110NPB2V3	M11	GND
J6	IO281PDB7V0	K20	IO106NPB2V3	M12	GND
J7	IO287NDB7V1	K21	IO109NDB2V3	M13	GND
J8	VCCIB7	K22	IO107NDB2V3	M14	VCC
J9	GND	L1	IO257PSB6V2	M15	GCB2/IO116PPB3V0
J10	VCC	L2	IO276PDB7V0	M16	GCA1/IO114PPB3V0
J11	VCC	L3	IO276NDB7V0	M17	GCC2/IO117PPB3V0
J12	VCC	L4	GFB0/IO274NPB7V0	M18	VCCPLC
J13	VCC	L5	GFA0/IO273NDB6V4	M19	GCA2/IO115PDB3V0
J14	GND	L6	GFB1/IO274PPB7V0	M20	IO115NDB3V0
J15	VCCIB2	L7	VCOMPLF	M21	IO126PDB3V1
J16	IO84NDB2V0	L8	GFC0/IO275NPB7V0	M22	IO124PSB3V1
J17	IO104NDB2V2	L9	VCC	N1	IO255PPB6V2
J18	IO104PDB2V2	L10	GND	N2	IO253NDB6V2
J19	IO106PPB2V3	L11	GND	N3	VMV6
J20	GNDQ	L12	GND	N4	GFC2/IO270PPB6V4
J21	IO109PDB2V3	L13	GND	N5	IO261PPB6V3
J22	IO107PDB2V3	L14	VCC	N6	IO263PDB6V3
K1	IO277NDB7V0	L15	GCC0/IO112NPB2V3	N7	IO263NDB6V3
K2	IO277PDB7V0	L16	GCB1/IO113PPB2V3	N8	VCCIB6
K3	GNDQ	L17	GCA0/IO114NPB3V0	N9	VCC
K4	IO279NDB7V0	L18	VCOMPLC	N10	GND
K5	IO283NDB7V1	L19	GCB0/IO113NPB2V3	N11	GND
K6	IO281NDB7V0	L20	IO110PPB2V3	N12	GND
K7	GFC1/IO275PPB7V0	L21	IO111NDB2V3	N13	GND
K8	VCCIB7	L22	IO111PDB2V3	N14	VCC
K9	VCC	M1	GNDQ	N15	VCCIB3
K10	GND	M2	IO255NPB6V2	N16	IO116NPB3V0

Package Pin Assignments

FG484		FG484		FG484	
Pin Number	A3PE3000 Function	Pin Number	A3PE3000 Function	Pin Number	A3PE3000 Function
N17	IO132NPB3V2	R9	VCCIB5	U1	IO240PPB6V0
N18	IO117NPB3V0	R10	VCCIB5	U2	IO238PDB6V0
N19	IO132PPB3V2	R11	IO196NDB5V0	U3	IO238NDB6V0
N20	GNDQ	R12	IO196PDB5V0	U4	GEB1/IO235PDB6V0
N21	IO126NDB3V1	R13	VCCIB4	U5	GEB0/IO235NDB6V0
N22	IO128PDB3V1	R14	VCCIB4	U6	VMV6
P1	IO247PDB6V1	R15	VMV3	U7	VCCPLE
P2	IO253PDB6V2	R16	VCCPLD	U8	IO233NPB5V4
P3	IO270NPB6V4	R17	GDB1/IO152PPB3V4	U9	IO222PPB5V3
P4	IO261NPB6V3	R18	GDC1/IO151PDB3V4	U10	IO206PDB5V1
P5	IO249PPB6V1	R19	IO138NDB3V3	U11	IO202PDB5V1
P6	IO259PDB6V3	R20	VCC	U12	IO194PDB5V0
P7	IO259NDB6V3	R21	IO130NDB3V2	U13	IO176NDB4V2
P8	VCCIB6	R22	IO134PDB3V2	U14	IO176PDB4V2
P9	GND	T1	IO243PPB6V1	U15	VMV4
P10	VCC	T2	IO245NDB6V1	U16	TCK
P11	VCC	T3	IO243NPB6V1	U17	VPUMP
P12	VCC	T4	IO241PDB6V0	U18	TRST
P13	VCC	T5	IO241NDB6V0	U19	GDA0/IO153NDB3V4
P14	GND	T6	GEC1/IO236PPB6V0	U20	IO144NDB3V3
P15	VCCIB3	T7	VCOMPLE	U21	IO140NDB3V3
P16	GDB0/IO152NPB3V4	T8	GNDQ	U22	IO142PDB3V3
P17	IO136NDB3V2	T9	GEA2/IO233PPB5V4	V1	IO239PDB6V0
P18	IO136PDB3V2	T10	IO206NDB5V1	V2	IO240NPB6V0
P19	IO138PDB3V3	T11	IO202NDB5V1	V3	GND
P20	VMV3	T12	IO194NDB5V0	V4	GEA1/IO234PDB6V0
P21	IO130PDB3V2	T13	IO186NDB4V4	V5	GEA0/IO234NDB6V0
P22	IO128NDB3V1	T14	IO186PDB4V4	V6	GNDQ
R1	IO247NDB6V1	T15	GNDQ	V7	GEC2/IO231PDB5V4
R2	IO245PDB6V1	T16	VCOMPLD	V8	IO222NPB5V3
R3	VCC	T17	VJTAG	V9	IO204NDB5V1
R4	IO249NPB6V1	T18	GDC0/IO151NDB3V4	V10	IO204PDB5V1
R5	IO251NDB6V2	T19	GDA1/IO153PDB3V4	V11	IO195NDB5V0
R6	IO251PDB6V2	T20	IO144PDB3V3	V12	IO195PDB5V0
R7	GEC0/IO236NPB6V0	T21	IO140PDB3V3	V13	IO178NDB4V3
R8	VMV5	T22	IO134NDB3V2	V14	IO178PDB4V3

FG484		FG484	
Pin Number	A3PE3000 Function	Pin Number	A3PE3000 Function
V15	IO155NDB4V0	Y7	IO220PDB5V3
V16	GDB2/IO155PDB4V0	Y8	VCC
V17	TDI	Y9	VCC
V18	GNDQ	Y10	IO200PDB5V0
V19	TDO	Y11	IO192PDB4V4
V20	GND	Y12	IO188NPB4V4
V21	IO146PDB3V4	Y13	IO187PSB4V4
V22	IO142NDB3V3	Y14	VCC
W1	IO239NDB6V0	Y15	VCC
W2	IO237PDB6V0	Y16	IO164NDB4V1
W3	IO230PSB5V4	Y17	IO164PDB4V1
W4	GND	Y18	GND
W5	IO232NDB5V4	Y19	IO158PPB4V0
W6	GEB2/IO232PDB5V4	Y20	IO150PDB3V4
W7	IO231NDB5V4	Y21	IO148NPB3V4
W8	IO214NDB5V2	Y22	VCCIB3
W9	IO214PDB5V2		
W10	IO200NDB5V0		
W11	IO192NDB4V4		
W12	IO184NDB4V3		
W13	IO184PDB4V3		
W14	IO156NDB4V0		
W15	GDC2/IO156PDB4V0		
W16	IO154NDB4V0		
W17	GDA2/IO154PDB4V0		
W18	TMS		
W19	GND		
W20	IO150NDB3V4		
W21	IO146NDB3V4		
W22	IO148PPB3V4		
Y1	VCCIB6		
Y2	IO237NDB6V0		
Y3	IO228NDB5V4		
Y4	IO224NDB5V3		
Y5	GND		
Y6	IO220NDB5V3		

FG676

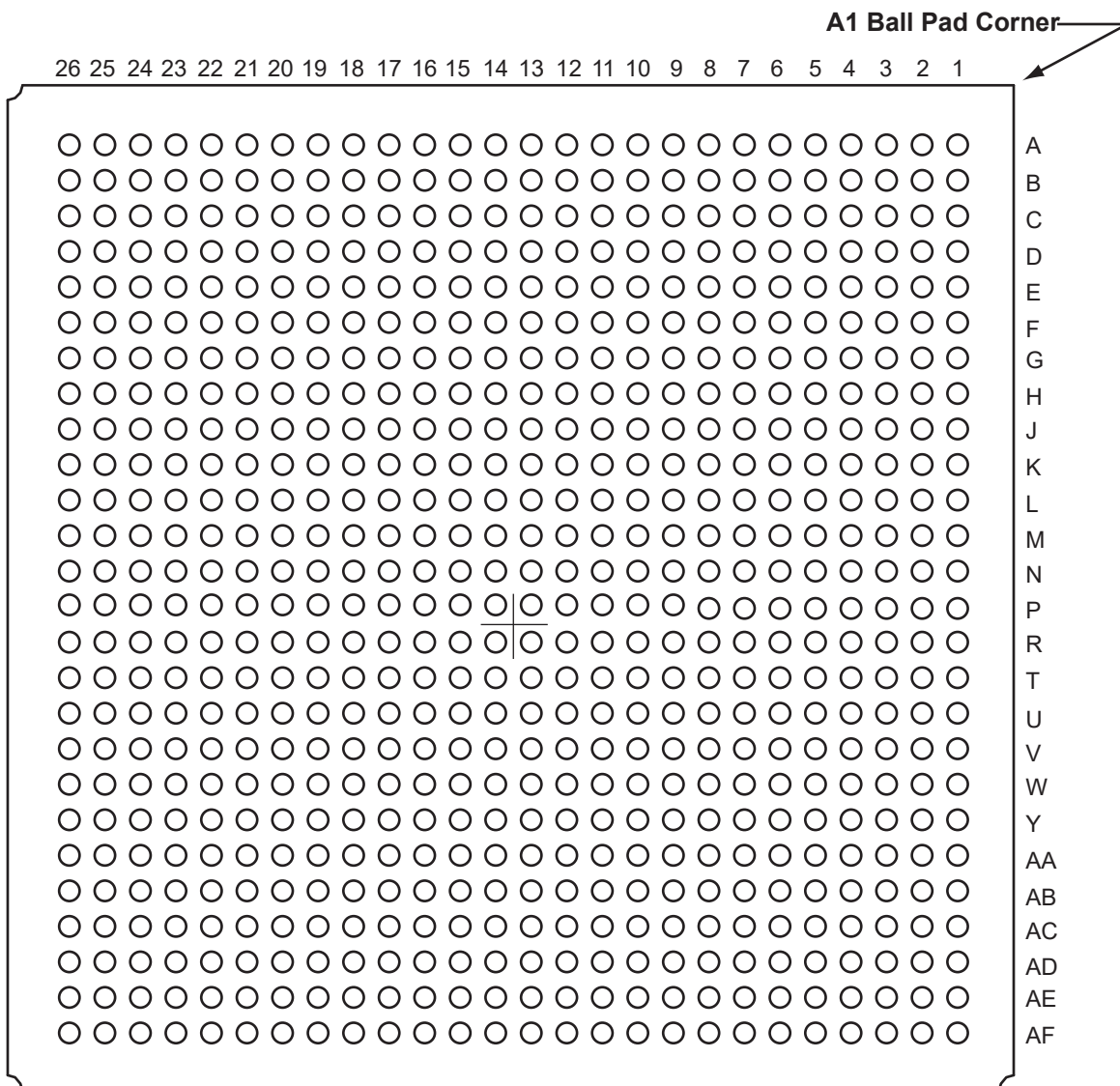

Note: This is the bottom view of the package.

Note

For Package Manufacturing and Environmental information, visit the Resource Center at <http://www.microsemi.com/products/fpga-soc/solutions>.

FG676	
Pin Number	A3PE1500 Function
A1	GND
A2	GND
A3	GAA0/IO00NDB0V0
A4	GAA1/IO00PDB0V0
A5	IO06NDB0V0
A6	IO09NDB0V1
A7	IO09PDB0V1
A8	IO14NDB0V1
A9	IO14PDB0V1
A10	IO22NDB0V2
A11	IO22PDB0V2
A12	IO26NDB0V3
A13	IO26PDB0V3
A14	IO30NDB0V3
A15	IO30PDB0V3
A16	IO34NDB1V0
A17	IO34PDB1V0
A18	IO38NDB1V0
A19	IO38PDB1V0
A20	IO41PDB1V1
A21	IO44PDB1V1
A22	IO49PDB1V2
A23	IO50PDB1V2
A24	GBC1/IO55PDB1V3
A25	GND
A26	GND
AA1	IO174PDB6V0
AA2	IO171PDB6V0
AA3	GEA1/IO167PPB6V0
AA4	GEC0/IO169NPB6V0
AA5	VCOMPLE
AA6	GND
AA7	IO165NDB5V3
AA8	GEB2/IO165PDB5V3
AA9	IO163PDB5V3
AA10	IO159NDB5V3

FG676	
Pin Number	A3PE1500 Function
AA11	IO153NDB5V2
AA12	IO147NDB5V1
AA13	IO139NDB5V0
AA14	IO137NDB5V0
AA15	IO123NDB4V1
AA16	IO123PDB4V1
AA17	IO117NDB4V0
AA18	IO117PDB4V0
AA19	GDB2/IO112PDB4V0
AA20	GNDQ
AA21	TDO
AA22	GND
AA23	GND
AA24	IO102NDB3V1
AA25	IO102PDB3V1
AA26	IO98NDB3V1
AB1	IO174NDB6V0
AB2	IO171NDB6V0
AB3	GEB1/IO168PPB6V0
AB4	GEA0/IO167NPB6V0
AB5	VCCPLE
AB6	GND
AB7	GND
AB8	IO156NDB5V2
AB9	IO156PDB5V2
AB10	IO150PDB5V1
AB11	IO155PDB5V2
AB12	IO142PDB5V0
AB13	IO135NDB5V0
AB14	IO135PDB5V0
AB15	IO132PDB4V2
AB16	IO129PDB4V2
AB17	IO121PDB4V1
AB18	IO119NDB4V1
AB19	IO112NDB4V0
AB20	VMV4

FG676	
Pin Number	A3PE1500 Function
AB21	TCK
AB22	TRST
AB23	GDC0/IO108NDB3V2
AB24	GDC1/IO108PDB3V2
AB25	IO104NDB3V2
AB26	IO104PDB3V2
AC1	IO170PDB6V0
AC2	GEB0/IO168NPB6V0
AC3	IO166NPB5V3
AC4	GNDQ
AC5	GND
AC6	IO160PDB5V3
AC7	IO161PDB5V3
AC8	IO154PDB5V2
AC9	GND
AC10	IO150NDB5V1
AC11	IO155NDB5V2
AC12	IO142NDB5V0
AC13	IO138NDB5V0
AC14	IO138PDB5V0
AC15	IO132NDB4V2
AC16	IO129NDB4V2
AC17	IO121NDB4V1
AC18	IO119PDB4V1
AC19	IO118NDB4V0
AC20	IO118PDB4V0
AC21	IO114PPB4V0
AC22	TMS
AC23	VJTAG
AC24	VMV3
AC25	IO106NDB3V2
AC26	IO106PDB3V2
AD1	IO170NDB6V0
AD2	GEA2/IO166PPB5V3
AD3	VMV5
AD4	GEC2/IO164PDB5V3

Package Pin Assignments

FG676		FG676		FG676	
Pin Number	A3PE1500 Function	Pin Number	A3PE1500 Function	Pin Number	A3PE1500 Function
AD5	IO162PDB5V3	AE15	IO134NDB4V2	AF25	GND
AD6	IO160NDB5V3	AE16	IO133NDB4V2	AF26	GND
AD7	IO161NDB5V3	AE17	IO127NDB4V2	B1	GND
AD8	IO154NDB5V2	AE18	IO130NDB4V2	B2	GND
AD9	IO148PDB5V1	AE19	IO126NDB4V1	B3	GND
AD10	IO151PDB5V2	AE20	IO124NDB4V1	B4	GND
AD11	IO144PDB5V1	AE21	IO120NDB4V1	B5	IO06PDB0V0
AD12	IO140PDB5V0	AE22	IO116PDB4V0	B6	IO04NDB0V0
AD13	IO143PDB5V1	AE23	GDC2/IO113PDB4V0	B7	IO07NDB0V0
AD14	IO141PDB5V0	AE24	GDA2/IO111PDB4V0	B8	IO11NDB0V1
AD15	IO134PDB4V2	AE25	GND	B9	IO10NDB0V1
AD16	IO133PDB4V2	AE26	GND	B10	IO16NDB0V2
AD17	IO127PDB4V2	AF1	GND	B11	IO20NDB0V2
AD18	IO130PDB4V2	AF2	GND	B12	IO24NDB0V3
AD19	IO126PDB4V1	AF3	GND	B13	IO23NDB0V2
AD20	IO124PDB4V1	AF4	GND	B14	IO28NDB0V3
AD21	IO120PDB4V1	AF5	IO158NPB5V2	B15	IO31NDB0V3
AD22	IO114NPB4V0	AF6	IO157NPB5V2	B16	IO32PDB1V0
AD23	TDI	AF7	IO152NPB5V2	B17	IO36PDB1V0
AD24	GNDQ	AF8	IO146NDB5V1	B18	IO37PDB1V0
AD25	GDA0/IO110NDB3V2	AF9	IO146PDB5V1	B19	IO42NPB1V1
AD26	GDA1/IO110PDB3V2	AF10	IO149NDB5V1	B20	IO41NDB1V1
AE1	GND	AF11	IO149PDB5V1	B21	IO44NDB1V1
AE2	GND	AF12	IO145NDB5V1	B22	IO49NDB1V2
AE3	GND	AF13	IO145PDB5V1	B23	IO50NDB1V2
AE4	IO164NDB5V3	AF14	IO136NDB5V0	B24	GBC0/IO55NDB1V3
AE5	IO162NDB5V3	AF15	IO136PDB5V0	B25	GND
AE6	IO158PPB5V2	AF16	IO131NDB4V2	B26	GND
AE7	IO157PPB5V2	AF17	IO131PDB4V2	C1	GND
AE8	IO152PPB5V2	AF18	IO128NDB4V2	C2	GND
AE9	IO148NDB5V1	AF19	IO128PDB4V2	C3	GND
AE10	IO151NDB5V2	AF20	IO122NDB4V1	C4	GND
AE11	IO144NDB5V1	AF21	IO122PDB4V1	C5	GAA2/IO221PDB7V3
AE12	IO140NDB5V0	AF22	IO116NDB4V0	C6	IO04PDB0V0
AE13	IO143NDB5V1	AF23	IO113NDB4V0	C7	IO07PDB0V0
AE14	IO141NDB5V0	AF24	IO111NDB4V0	C8	IO11PDB0V1

FG676	
Pin Number	A3PE1500 Function
C9	IO10PDB0V1
C10	IO16PDB0V2
C11	IO20PDB0V2
C12	IO24PDB0V3
C13	IO23PDB0V2
C14	IO28PDB0V3
C15	IO31PDB0V3
C16	IO32NDB1V0
C17	IO36NDB1V0
C18	IO37NDB1V0
C19	IO45NDB1V1
C20	IO42PPB1V1
C21	IO46NPB1V1
C22	IO48NPB1V2
C23	GBB0/IO56NPB1V3
C24	VMV1
C25	GBC2/IO60PDB2V0
C26	IO60NDB2V0
D1	IO218NDB7V3
D2	IO218PDB7V3
D3	GND
D4	VMV7
D5	IO221NDB7V3
D6	GAC0/IO02NDB0V0
D7	GAC1/IO02PDB0V0
D8	IO05NDB0V0
D9	IO08PDB0V1
D10	IO12NDB0V1
D11	IO18NDB0V2
D12	IO17NDB0V2
D13	IO25NDB0V3
D14	IO29NDB0V3
D15	IO33NDB1V0
D16	IO40PDB1V1
D17	IO43NDB1V1
D18	IO47PDB1V1

FG676	
Pin Number	A3PE1500 Function
D19	IO45PDB1V1
D20	IO46PPB1V1
D21	IO48PPB1V2
D22	GBA0/IO57NPB1V3
D23	GNDQ
D24	GBB1/IO56PPB1V3
D25	GBB2/IO59PDB2V0
D26	IO59NDB2V0
E1	IO212PDB7V2
E2	IO211NDB7V2
E3	IO211PDB7V2
E4	IO220NPB7V3
E5	GNDQ
E6	GAB2/IO220PPB7V3
E7	GAB1/IO01PDB0V0
E8	IO05PDB0V0
E9	IO08NDB0V1
E10	IO12PDB0V1
E11	IO18PDB0V2
E12	IO17PDB0V2
E13	IO25PDB0V3
E14	IO29PDB0V3
E15	IO33PDB1V0
E16	IO40NDB1V1
E17	IO43PDB1V1
E18	IO47NDB1V1
E19	IO54NDB1V3
E20	IO52NDB1V2
E21	IO52PDB1V2
E22	VCCPLB
E23	GBA1/IO57PPB1V3
E24	IO63PDB2V0
E25	IO63NDB2V0
E26	IO68PDB2V1
F1	IO212NDB7V2
F2	IO203PPB7V1

FG676	
Pin Number	A3PE1500 Function
F3	IO213NDB7V2
F4	IO213PDB7V2
F5	GND
F6	VCCPLA
F7	GAB0/IO01NDB0V0
F8	GNDQ
F9	IO03PDB0V0
F10	IO13PDB0V1
F11	IO15PDB0V1
F12	IO19PDB0V2
F13	IO21PDB0V2
F14	IO27NDB0V3
F15	IO35PDB1V0
F16	IO39NDB1V0
F17	IO51PDB1V2
F18	IO53PDB1V2
F19	IO54PDB1V3
F20	VMV2
F21	VCOMPLB
F22	IO61PDB2V0
F23	IO61NDB2V0
F24	IO66PDB2V1
F25	IO66NDB2V1
F26	IO68NDB2V1
G1	IO203NPB7V1
G2	IO207NDB7V2
G3	IO207PDB7V2
G4	IO216NDB7V3
G5	IO216PDB7V3
G6	VCOMPLA
G7	VMV0
G8	VCC
G9	IO03NDB0V0
G10	IO13NDB0V1
G11	IO15NDB0V1
G12	IO19NDB0V2

Package Pin Assignments

FG676		FG676		FG676	
Pin Number	A3PE1500 Function	Pin Number	A3PE1500 Function	Pin Number	A3PE1500 Function
G13	IO21NDB0V2	H23	IO69PDB2V1	K7	IO217NDB7V3
G14	IO27PDB0V3	H24	IO76PDB2V2	K8	VCCIB7
G15	IO35NDB1V0	H25	IO76NDB2V2	K9	VCC
G16	IO39PDB1V0	H26	IO78NDB2V2	K10	GND
G17	IO51NDB1V2	J1	IO197NDB7V0	K11	GND
G18	IO53NDB1V2	J2	IO197PDB7V0	K12	GND
G19	VCCIB1	J3	VMV7	K13	GND
G20	GBA2/IO58PPB2V0	J4	IO215NDB7V3	K14	GND
G21	GNDQ	J5	IO215PDB7V3	K15	GND
G22	IO64NDB2V1	J6	IO214PDB7V3	K16	GND
G23	IO64PDB2V1	J7	IO214NDB7V3	K17	GND
G24	IO72PDB2V2	J8	VCCIB7	K18	VCC
G25	IO72NDB2V2	J9	VCC	K19	VCCIB2
G26	IO78PDB2V2	J10	VCC	K20	IO65PDB2V1
H1	IO208NDB7V2	J11	VCC	K21	IO65NDB2V1
H2	IO208PDB7V2	J12	VCC	K22	IO74PDB2V2
H3	IO209NDB7V2	J13	VCC	K23	IO74NDB2V2
H4	IO209PDB7V2	J14	VCC	K24	IO75PDB2V2
H5	IO219NDB7V3	J15	VCC	K25	IO75NDB2V2
H6	GAC2/IO219PDB7V3	J16	VCC	K26	IO84PDB2V3
H7	VCCIB7	J17	VCC	L1	IO195NDB7V0
H8	VCC	J18	VCC	L2	IO198PPB7V0
H9	VCCIB0	J19	VCCIB2	L3	GNDQ
H10	VCCIB0	J20	IO62PDB2V0	L4	IO201PDB7V1
H11	VCCIB0	J21	IO62NDB2V0	L5	IO201NDB7V1
H12	VCCIB0	J22	IO70NDB2V1	L6	IO210NDB7V2
H13	VCCIB0	J23	IO69NDB2V1	L7	IO210PDB7V2
H14	VCCIB1	J24	VMV2	L8	VCCIB7
H15	VCCIB1	J25	IO80PDB2V3	L9	VCC
H16	VCCIB1	J26	IO80NDB2V3	L10	GND
H17	VCCIB1	K1	IO195PDB7V0	L11	GND
H18	VCCIB1	K2	IO199NDB7V1	L12	GND
H19	VCC	K3	IO199PDB7V1	L13	GND
H20	VCC	K4	IO205NDB7V1	L14	GND
H21	IO58NPB2V0	K5	IO205PDB7V1	L15	GND
H22	IO70PDB2V1	K6	IO217PDB7V3	L16	GND

FG676	
Pin Number	A3PE1500 Function
L17	GND
L18	VCC
L19	VCCIB2
L20	IO67PDB2V1
L21	IO67NDB2V1
L22	IO71PDB2V2
L23	IO71NDB2V2
L24	GNDQ
L25	IO82PDB2V3
L26	IO84NDB2V3
M1	IO198NPB7V0
M2	IO202PDB7V1
M3	IO202NDB7V1
M4	IO206NDB7V1
M5	IO206PDB7V1
M6	IO204NDB7V1
M7	IO204PDB7V1
M8	VCCIB7
M9	VCC
M10	GND
M11	GND
M12	GND
M13	GND
M14	GND
M15	GND
M16	GND
M17	GND
M18	VCC
M19	VCCIB2
M20	IO73NDB2V2
M21	IO73PDB2V2
M22	IO81PPB2V3
M23	IO77PDB2V2
M24	IO77NDB2V2
M25	IO82NDB2V3
M26	IO83PDB2V3

FG676	
Pin Number	A3PE1500 Function
N1	GFB0/IO191NPB7V0
N2	VCOMPLF
N3	GFB1/IO191PPB7V0
N4	IO196PDB7V0
N5	GFA0/IO190NDB6V2
N6	IO200PDB7V1
N7	IO200NDB7V1
N8	VCCIB7
N9	VCC
N10	GND
N11	GND
N12	GND
N13	GND
N14	GND
N15	GND
N16	GND
N17	GND
N18	VCC
N19	VCCIB2
N20	IO79PDB2V3
N21	IO79NDB2V3
N22	GCA2/IO88PPB3V0
N23	IO81NPB2V3
N24	GCA0/IO87NDB3V0
N25	GCB0/IO86NPB2V3
N26	IO83NDB2V3
P1	GFA2/IO189PDB6V2
P2	VCCPLF
P3	IO193PPB7V0
P4	IO196NDB7V0
P5	GFA1/IO190PDB6V2
P6	IO194PDB7V0
P7	IO194NDB7V0
P8	VCCIB6
P9	VCC
P10	GND

FG676	
Pin Number	A3PE1500 Function
P11	GND
P12	GND
P13	GND
P14	GND
P15	GND
P16	GND
P17	GND
P18	VCC
P19	VCCIB3
P20	GCC0/IO85NDB2V3
P21	GCC1/IO85PDB2V3
P22	GCB1/IO86PPB2V3
P23	IO88NPB3V0
P24	GCA1/IO87PDB3V0
P25	VCCPLC
P26	VCOMPLC
R1	IO189NDB6V2
R2	IO185PDB6V2
R3	IO187NPB6V2
R4	IO193NPB7V0
R5	GFC2/IO187PPB6V2
R6	GFC1/IO192PDB7V0
R7	GFC0/IO192NDB7V0
R8	VCCIB6
R9	VCC
R10	GND
R11	GND
R12	GND
R13	GND
R14	GND
R15	GND
R16	GND
R17	GND
R18	VCC
R19	VCCIB3
R20	NC

Package Pin Assignments

FG676		FG676		FG676	
Pin Number	A3PE1500 Function	Pin Number	A3PE1500 Function	Pin Number	A3PE1500 Function
R21	IO89NDB3V0	U5	IO182PDB6V1	V15	VCC
R22	GCB2/IO89PDB3V0	U6	IO178PDB6V1	V16	VCC
R23	IO90NDB3V0	U7	IO178NDB6V1	V17	VCC
R24	GCC2/IO90PDB3V0	U8	VCCIB6	V18	VCC
R25	IO91PDB3V0	U9	VCC	V19	VCCIB3
R26	IO91NDB3V0	U10	GND	V20	IO107PDB3V2
T1	IO186PDB6V2	U11	GND	V21	IO107NDB3V2
T2	IO185NDB6V2	U12	GND	V22	IO103NDB3V2
T3	GNDQ	U13	GND	V23	IO103PDB3V2
T4	IO180PDB6V1	U14	GND	V24	VMV3
T5	IO180NDB6V1	U15	GND	V25	IO95NDB3V1
T6	IO188NDB6V2	U16	GND	V26	IO94PDB3V0
T7	GFB2/IO188PDB6V2	U17	GND	W1	IO179NDB6V1
T8	VCCIB6	U18	VCC	W2	IO179PDB6V1
T9	VCC	U19	VCCIB3	W3	IO177NDB6V1
T10	GND	U20	NC	W4	IO177PDB6V1
T11	GND	U21	IO101NDB3V1	W5	IO172PDB6V0
T12	GND	U22	IO101PDB3V1	W6	IO172NDB6V0
T13	GND	U23	IO92NDB3V0	W7	VCC
T14	GND	U24	IO92PDB3V0	W8	VCC
T15	GND	U25	IO95PDB3V1	W9	VCCIB5
T16	GND	U26	IO93NPB3V0	W10	VCCIB5
T17	GND	V1	IO183PDB6V2	W11	VCCIB5
T18	VCC	V2	IO183NDB6V2	W12	VCCIB5
T19	VCCIB3	V3	VMV6	W13	VCCIB5
T20	IO99PDB3V1	V4	IO181PDB6V1	W14	VCCIB4
T21	IO99NDB3V1	V5	IO181NDB6V1	W15	VCCIB4
T22	IO97PDB3V1	V6	IO176PDB6V1	W16	VCCIB4
T23	IO97NDB3V1	V7	IO176NDB6V1	W17	VCCIB4
T24	GNDQ	V8	VCCIB6	W18	VCCIB4
T25	IO93PPB3V0	V9	VCC	W19	VCC
T26	NC	V10	VCC	W20	VCCIB3
U1	IO186NDB6V2	V11	VCC	W21	GDB0/IO109NDB3V2
U2	IO184NDB6V2	V12	VCC	W22	GDB1/IO109PDB3V2
U3	IO184PDB6V2	V13	VCC	W23	IO105NDB3V2
U4	IO182NDB6V1	V14	VCC	W24	IO105PDB3V2

FG676	
Pin Number	A3PE1500 Function
W25	IO96PDB3V1
W26	IO94NDB3V0
Y1	IO175NDB6V1
Y2	IO175PDB6V1
Y3	IO173NDB6V0
Y4	IO173PDB6V0
Y5	GEC1/IO169PPB6V0
Y6	GNDQ
Y7	VMV6
Y8	VCCIB5
Y9	IO163NDB5V3
Y10	IO159PDB5V3
Y11	IO153PDB5V2
Y12	IO147PDB5V1
Y13	IO139PDB5V0
Y14	IO137PDB5V0
Y15	IO125NDB4V1
Y16	IO125PDB4V1
Y17	IO115NDB4V0
Y18	IO115PDB4V0
Y19	VCC
Y20	VPUMP
Y21	VCOMPLD
Y22	VCCPLD
Y23	IO100NDB3V1
Y24	IO100PDB3V1
Y25	IO96NDB3V1
Y26	IO98PDB3V1

FG896

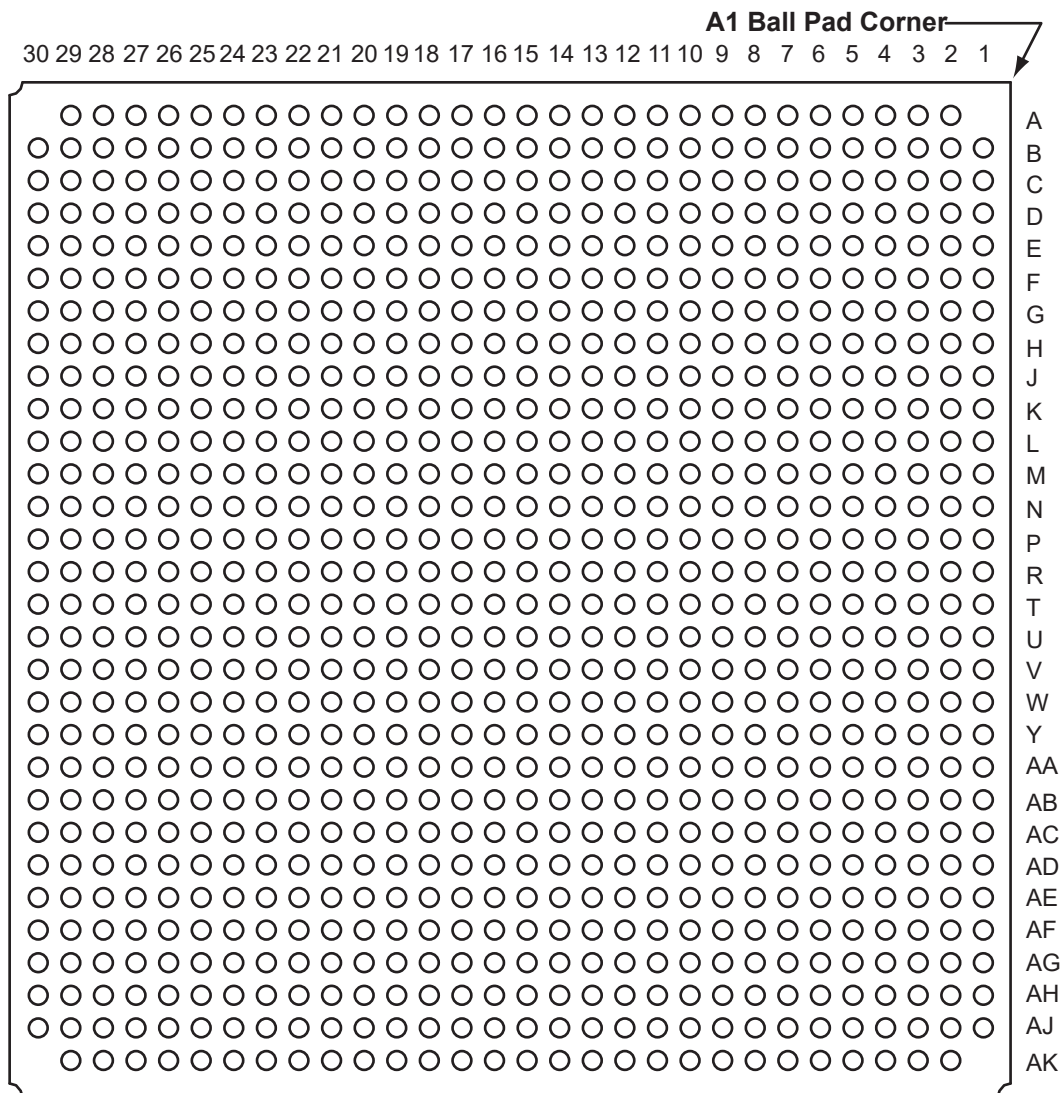

Note: This is the bottom view of the package.

Note

For Package Manufacturing and Environmental information, visit the Resource Center at <http://www.microsemi.com/products/fpga-soc/solutions>.

FG896		FG896		FG896	
Pin Number	A3PE3000 Function	Pin Number	A3PE3000 Function	Pin Number	A3PE3000 Function
A2	GND	AA9	GEB1/IO235PPB6V0	AB15	IO198PDB5V0
A3	GND	AA10	VCC	AB16	IO192NDB4V4
A4	IO14NPB0V1	AA11	IO226PPB5V4	AB17	IO192PDB4V4
A5	GND	AA12	VCCIB5	AB18	IO178NDB4V3
A6	IO07NPB0V0	AA13	VCCIB5	AB19	IO178PDB4V3
A7	GND	AA14	VCCIB5	AB20	IO174NDB4V2
A8	IO09NDB0V1	AA15	VCCIB5	AB21	IO162NPB4V1
A9	IO17NDB0V2	AA16	VCCIB4	AB22	VCC
A10	IO17PDB0V2	AA17	VCCIB4	AB23	VCCPLD
A11	IO21NDB0V2	AA18	VCCIB4	AB24	VCCIB3
A12	IO21PDB0V2	AA19	VCCIB4	AB25	IO150PDB3V4
A13	IO33NDB0V4	AA20	IO174PDB4V2	AB26	IO148PDB3V4
A14	IO33PDB0V4	AA21	VCC	AB27	IO147NDB3V4
A15	IO35NDB0V4	AA22	IO142NPB3V3	AB28	IO145PDB3V3
A16	IO35PDB0V4	AA23	IO144NDB3V3	AB29	IO143PDB3V3
A17	IO41NDB1V0	AA24	IO144PDB3V3	AB30	IO137PDB3V2
A18	IO43NDB1V0	AA25	IO146NDB3V4	AC1	IO254PDB6V2
A19	IO43PDB1V0	AA26	IO146PDB3V4	AC2	IO254NDB6V2
A20	IO45NDB1V0	AA27	IO147PDB3V4	AC3	IO240PDB6V0
A21	IO45PDB1V0	AA28	IO139NDB3V3	AC4	GEC1/IO236PDB6V0
A22	IO57NDB1V2	AA29	IO139PDB3V3	AC5	IO237PDB6V0
A23	IO57PDB1V2	AA30	IO133NDB3V2	AC6	IO237NDB6V0
A24	GND	AB1	IO256NDB6V2	AC7	VCOMPLE
A25	IO69PPB1V3	AB2	IO244PDB6V1	AC8	GND
A26	GND	AB3	IO244NDB6V1	AC9	IO226NPB5V4
A27	GBC1/IO79PPB1V4	AB4	IO241PDB6V0	AC10	IO222NDB5V3
A28	GND	AB5	IO241NDB6V0	AC11	IO216NPB5V2
A29	GND	AB6	IO243NPB6V1	AC12	IO210NPB5V2
AA1	IO256PDB6V2	AB7	VCCIB6	AC13	IO204NDB5V1
AA2	IO248PDB6V1	AB8	VCCPLE	AC14	IO204PDB5V1
AA3	IO248NDB6V1	AB9	VCC	AC15	IO194NDB5V0
AA4	IO246NDB6V1	AB10	IO222PDB5V3	AC16	IO188NDB4V4
AA5	GEA1/IO234PDB6V0	AB11	IO218PPB5V3	AC17	IO188PDB4V4
AA6	GEA0/IO234NDB6V0	AB12	IO206NDB5V1	AC18	IO182PPB4V3
AA7	IO243PPB6V1	AB13	IO206PDB5V1	AC19	IO170NPB4V2
AA8	IO245NDB6V1	AB14	IO198NDB5V0	AC20	IO164NDB4V1

Package Pin Assignments

FG896		FG896		FG896	
Pin Number	A3PE3000 Function	Pin Number	A3PE3000 Function	Pin Number	A3PE3000 Function
AC21	IO164PDB4V1	AD27	GDA0/IO153NDB3V4	AF3	VCCIB6
AC22	IO162PPB4V1	AD28	GDC0/IO151NDB3V4	AF4	IO220NPB5V3
AC23	GND	AD29	GDC1/IO151PDB3V4	AF5	VCC
AC24	VCOMPLD	AD30	GND	AF6	IO228NDB5V4
AC25	IO150NDB3V4	AE1	IO242PPB6V1	AF7	VCCIB5
AC26	IO148NDB3V4	AE2	VCC	AF8	IO230PDB5V4
AC27	GDA1/IO153PDB3V4	AE3	IO239PDB6V0	AF9	IO229NDB5V4
AC28	IO145NDB3V3	AE4	IO239NDB6V0	AF10	IO229PDB5V4
AC29	IO143NDB3V3	AE5	VMV6	AF11	IO214PPB5V2
AC30	IO137NDB3V2	AE6	GND	AF12	IO208NDB5V1
AD1	GND	AE7	GNDQ	AF13	IO208PDB5V1
AD2	IO242NPB6V1	AE8	IO230NDB5V4	AF14	IO200PDB5V0
AD3	IO240NDB6V0	AE9	IO224NPB5V3	AF15	IO196NDB5V0
AD4	GEC0/IO236NDB6V0	AE10	IO214NPB5V2	AF16	IO186NDB4V4
AD5	VCCIB6	AE11	IO212NDB5V2	AF17	IO186PDB4V4
AD6	GNDQ	AE12	IO212PDB5V2	AF18	IO180NDB4V3
AD7	VCC	AE13	IO202NPB5V1	AF19	IO180PDB4V3
AD8	VMV5	AE14	IO200NDB5V0	AF20	IO168NDB4V1
AD9	VCCIB5	AE15	IO196PDB5V0	AF21	IO168PDB4V1
AD10	IO224PPB5V3	AE16	IO190NDB4V4	AF22	IO160NDB4V0
AD11	IO218NPB5V3	AE17	IO184PDB4V3	AF23	IO158NPB4V0
AD12	IO216PPB5V2	AE18	IO184NDB4V3	AF24	VCCIB4
AD13	IO210PPB5V2	AE19	IO172PDB4V2	AF25	IO154NPB4V0
AD14	IO202PPB5V1	AE20	IO172NDB4V2	AF26	VCC
AD15	IO194PDB5V0	AE21	IO166NDB4V1	AF27	TDO
AD16	IO190PDB4V4	AE22	IO160PDB4V0	AF28	VCCIB3
AD17	IO182NPB4V3	AE23	GNDQ	AF29	GNDQ
AD18	IO176NDB4V2	AE24	VMV4	AF30	GND
AD19	IO176PDB4V2	AE25	GND	AG1	IO238NPB6V0
AD20	IO170PPB4V2	AE26	GDB0/IO152NDB3V4	AG2	VCC
AD21	IO166PDB4V1	AE27	GDB1/IO152PDB3V4	AG3	IO232NPB5V4
AD22	VCCIB4	AE28	VMV3	AG4	GND
AD23	TCK	AE29	VCC	AG5	IO220PPB5V3
AD24	VCC	AE30	IO149PDB3V4	AG6	IO228PDB5V4
AD25	TRST	AF1	GND	AG7	IO231NDB5V4
AD26	VCCIB3	AF2	IO238PPB6V0	AG8	GEC2/IO231PDB5V4

FG896		FG896		FG896	
Pin Number	A3PE3000 Function	Pin Number	A3PE3000 Function	Pin Number	A3PE3000 Function
AG9	IO225NPB5V3	AH15	IO195NDB5V0	AJ21	IO173PDB4V2
AG10	IO223NPB5V3	AH16	IO185NDB4V3	AJ22	IO163NDB4V1
AG11	IO221PDB5V3	AH17	IO185PDB4V3	AJ23	IO163PDB4V1
AG12	IO221NDB5V3	AH18	IO181PDB4V3	AJ24	IO167NPB4V1
AG13	IO205NPB5V1	AH19	IO177NDB4V2	AJ25	VCC
AG14	IO199NDB5V0	AH20	IO171NPB4V2	AJ26	IO156NPB4V0
AG15	IO199PDB5V0	AH21	IO165PPB4V1	AJ27	VCC
AG16	IO187NDB4V4	AH22	IO161PPB4V0	AJ28	TMS
AG17	IO187PDB4V4	AH23	IO157NDB4V0	AJ29	GND
AG18	IO181NDB4V3	AH24	IO157PDB4V0	AJ30	GND
AG19	IO171PPB4V2	AH25	IO155NDB4V0	AK2	GND
AG20	IO165NPB4V1	AH26	VCCIB4	AK3	GND
AG21	IO161NPB4V0	AH27	TDI	AK4	IO217PPB5V2
AG22	IO159NDB4V0	AH28	VCC	AK5	GND
AG23	IO159PDB4V0	AH29	VPUMP	AK6	IO215PPB5V2
AG24	IO158PPB4V0	AH30	GND	AK7	GND
AG25	GDB2/IO155PDB4V0	AJ1	GND	AK8	IO207NDB5V1
AG26	GDA2/IO154PPB4V0	AJ2	GND	AK9	IO207PDB5V1
AG27	GND	AJ3	GEA2/IO233PPB5V4	AK10	IO201NDB5V0
AG28	VJTAG	AJ4	VCC	AK11	IO201PDB5V0
AG29	VCC	AJ5	IO217NPB5V2	AK12	IO193NDB4V4
AG30	IO149NDB3V4	AJ6	VCC	AK13	IO193PDB4V4
AH1	GND	AJ7	IO215NPB5V2	AK14	IO197PDB5V0
AH2	IO233NPB5V4	AJ8	IO213NDB5V2	AK15	IO191NDB4V4
AH3	VCC	AJ9	IO213PDB5V2	AK16	IO191PDB4V4
AH4	GEB2/IO232PPB5V4	AJ10	IO209NDB5V1	AK17	IO189NDB4V4
AH5	VCCIB5	AJ11	IO209PDB5V1	AK18	IO189PDB4V4
AH6	IO219NDB5V3	AJ12	IO203NDB5V1	AK19	IO179PPB4V3
AH7	IO219PDB5V3	AJ13	IO203PDB5V1	AK20	IO175NDB4V2
AH8	IO227NDB5V4	AJ14	IO197NDB5V0	AK21	IO175PDB4V2
AH9	IO227PDB5V4	AJ15	IO195PDB5V0	AK22	IO169NDB4V1
AH10	IO225PPB5V3	AJ16	IO183NDB4V3	AK23	IO169PDB4V1
AH11	IO223PPB5V3	AJ17	IO183PDB4V3	AK24	GND
AH12	IO211NDB5V2	AJ18	IO179NPB4V3	AK25	IO167PPB4V1
AH13	IO211PDB5V2	AJ19	IO177PDB4V2	AK26	GND
AH14	IO205PPB5V1	AJ20	IO173NDB4V2	AK27	GDC2/IO156PPB4V0

Package Pin Assignments

FG896		FG896		FG896	
Pin Number	A3PE3000 Function	Pin Number	A3PE3000 Function	Pin Number	A3PE3000 Function
AK28	GND	C5	VCCIB0	D11	IO11PDB0V1
AK29	GND	C6	IO03PDB0V0	D12	IO23NDB0V2
B1	GND	C7	IO03NDB0V0	D13	IO23PDB0V2
B2	GND	C8	GAB1/IO01PDB0V0	D14	IO27PDB0V3
B3	GAA2/IO309PPB7V4	C9	IO05PDB0V0	D15	IO40PDB0V4
B4	VCC	C10	IO15NPB0V1	D16	IO47NDB1V0
B5	IO14PPB0V1	C11	IO25NDB0V3	D17	IO47PDB1V0
B6	VCC	C12	IO25PDB0V3	D18	IO55NPB1V1
B7	IO07PPB0V0	C13	IO31NPB0V3	D19	IO65NDB1V3
B8	IO09PDB0V1	C14	IO27NDB0V3	D20	IO65PDB1V3
B9	IO15PPB0V1	C15	IO39NDB0V4	D21	IO71NDB1V3
B10	IO19NDB0V2	C16	IO39PDB0V4	D22	IO71PDB1V3
B11	IO19PDB0V2	C17	IO55PPB1V1	D23	IO73NDB1V4
B12	IO29NDB0V3	C18	IO51PDB1V1	D24	IO73PDB1V4
B13	IO29PDB0V3	C19	IO59NDB1V2	D25	IO74NDB1V4
B14	IO31PPB0V3	C20	IO63NDB1V2	D26	GBB0/IO80NPB1V4
B15	IO37NDB0V4	C21	IO63PDB1V2	D27	GND
B16	IO37PDB0V4	C22	IO67NDB1V3	D28	GBA0/IO81NPB1V4
B17	IO41PDB1V0	C23	IO67PDB1V3	D29	VCC
B18	IO51NDB1V1	C24	IO75NDB1V4	D30	GBA2/IO82PPB2V0
B19	IO59PDB1V2	C25	IO75PDB1V4	E1	GND
B20	IO53PDB1V1	C26	VCCIB1	E2	IO303NPB7V3
B21	IO53NDB1V1	C27	IO64PPB1V2	E3	VCCIB7
B22	IO61NDB1V2	C28	VCC	E4	IO305PPB7V3
B23	IO61PDB1V2	C29	GBA1/IO81PPB1V4	E5	VCC
B24	IO69NPB1V3	C30	GND	E6	GAC0/IO02NDB0V0
B25	VCC	D1	IO303PPB7V3	E7	VCCIB0
B26	GBC0/IO79NPB1V4	D2	VCC	E8	IO06PPB0V0
B27	VCC	D3	IO305NPB7V3	E9	IO24NDB0V2
B28	IO64NPB1V2	D4	GND	E10	IO24PDB0V2
B29	GND	D5	GAA1/IO00PPB0V0	E11	IO13NDB0V1
B30	GND	D6	GAC1/IO02PDB0V0	E12	IO13PDB0V1
C1	GND	D7	IO06NPB0V0	E13	IO34NDB0V4
C2	IO309NPB7V4	D8	GAB0/IO01NDB0V0	E14	IO34PDB0V4
C3	VCC	D9	IO05NDB0V0	E15	IO40NDB0V4
C4	GAA0/IO00NPB0V0	D10	IO11NDB0V1	E16	IO49NDB1V1

FG896	
Pin Number	A3PE3000 Function
E17	IO49PDB1V1
E18	IO50PDB1V1
E19	IO58PDB1V2
E20	IO60NDB1V2
E21	IO77PDB1V4
E22	IO68NDB1V3
E23	IO68PDB1V3
E24	VCCIB1
E25	IO74PDB1V4
E26	VCC
E27	GBB1/IO80PPB1V4
E28	VCCIB2
E29	IO82NPB2V0
E30	GND
F1	IO296PPB7V2
F2	VCC
F3	IO306PDB7V4
F4	IO297PDB7V2
F5	VMV7
F6	GND
F7	GNDQ
F8	IO12NDB0V1
F9	IO12PDB0V1
F10	IO10PDB0V1
F11	IO16PDB0V1
F12	IO22NDB0V2
F13	IO30NDB0V3
F14	IO30PDB0V3
F15	IO36PDB0V4
F16	IO48NDB1V0
F17	IO48PDB1V0
F18	IO50NDB1V1
F19	IO58NDB1V2
F20	IO60PDB1V2
F21	IO77NDB1V4
F22	IO72NDB1V3

FG896	
Pin Number	A3PE3000 Function
F23	IO72PDB1V3
F24	GNDQ
F25	GND
F26	VMV2
F27	IO86PDB2V0
F28	IO92PDB2V1
F29	VCC
F30	IO100NPB2V2
G1	GND
G2	IO296NPB7V2
G3	IO306NDB7V4
G4	IO297NDB7V2
G5	VCCIB7
G6	GNDQ
G7	VCC
G8	VMV0
G9	VCCIB0
G10	IO10NDB0V1
G11	IO16NDB0V1
G12	IO22PDB0V2
G13	IO26PPB0V3
G14	IO38NPB0V4
G15	IO36NDB0V4
G16	IO46NDB1V0
G17	IO46PDB1V0
G18	IO56NDB1V1
G19	IO56PDB1V1
G20	IO66NDB1V3
G21	IO66PDB1V3
G22	VCCIB1
G23	VMV1
G24	VCC
G25	GNDQ
G26	VCCIB2
G27	IO86NDB2V0
G28	IO92NDB2V1

FG896	
Pin Number	A3PE3000 Function
G29	IO100PPB2V2
G30	GND
H1	IO294PDB7V2
H2	IO294NDB7V2
H3	IO300NDB7V3
H4	IO300PDB7V3
H5	IO295PDB7V2
H6	IO299PDB7V3
H7	VCOMPLA
H8	GND
H9	IO08NDB0V0
H10	IO08PDB0V0
H11	IO18PDB0V2
H12	IO26NPB0V3
H13	IO28NDB0V3
H14	IO28PDB0V3
H15	IO38PPB0V4
H16	IO42NDB1V0
H17	IO52NDB1V1
H18	IO52PDB1V1
H19	IO62NDB1V2
H20	IO62PDB1V2
H21	IO70NDB1V3
H22	IO70PDB1V3
H23	GND
H24	VCOMPLB
H25	GBC2/IO84PDB2V0
H26	IO84NDB2V0
H27	IO96PDB2V1
H28	IO96NDB2V1
H29	IO89PDB2V0
H30	IO89NDB2V0
J1	IO290NDB7V2
J2	IO290PDB7V2
J3	IO302NDB7V3
J4	IO302PDB7V3

Package Pin Assignments

FG896		FG896		FG896	
Pin Number	A3PE3000 Function	Pin Number	A3PE3000 Function	Pin Number	A3PE3000 Function
J5	IO295NDB7V2	K11	IO04PPB0V0	L17	VCC
J6	IO299NDB7V3	K12	VCCIB0	L18	VCC
J7	VCCIB7	K13	VCCIB0	L19	VCC
J8	VCCPLA	K14	VCCIB0	L20	VCC
J9	VCC	K15	VCCIB0	L21	IO78NPB1V4
J10	IO04NPB0V0	K16	VCCIB1	L22	IO104NPB2V2
J11	IO18NDB0V2	K17	VCCIB1	L23	IO98NDB2V2
J12	IO20NDB0V2	K18	VCCIB1	L24	IO98PDB2V2
J13	IO20PDB0V2	K19	VCCIB1	L25	IO87PDB2V0
J14	IO32NDB0V3	K20	IO76PPB1V4	L26	IO87NDB2V0
J15	IO32PDB0V3	K21	VCC	L27	IO97PDB2V1
J16	IO42PDB1V0	K22	IO78PPB1V4	L28	IO101PDB2V2
J17	IO44NDB1V0	K23	IO88NDB2V0	L29	IO103PDB2V2
J18	IO44PDB1V0	K24	IO88PDB2V0	L30	IO119NDB3V0
J19	IO54NDB1V1	K25	IO94PDB2V1	M1	IO282NDB7V1
J20	IO54PDB1V1	K26	IO94NDB2V1	M2	IO282PDB7V1
J21	IO76NPB1V4	K27	IO85PDB2V0	M3	IO292NDB7V2
J22	VCC	K28	IO85NDB2V0	M4	IO292PDB7V2
J23	VCCPLB	K29	IO93PDB2V1	M5	IO283NDB7V1
J24	VCCIB2	K30	IO93NDB2V1	M6	IO285PDB7V1
J25	IO90PDB2V1	L1	IO286NDB7V1	M7	IO287PDB7V1
J26	IO90NDB2V1	L2	IO286PDB7V1	M8	IO289PDB7V1
J27	GBB2/IO83PDB2V0	L3	IO298NDB7V3	M9	IO289NDB7V1
J28	IO83NDB2V0	L4	IO298PDB7V3	M10	VCCIB7
J29	IO91PDB2V1	L5	IO283PDB7V1	M11	VCC
J30	IO91NDB2V1	L6	IO291NDB7V2	M12	GND
K1	IO288NDB7V1	L7	IO291PDB7V2	M13	GND
K2	IO288PDB7V1	L8	IO293PDB7V2	M14	GND
K3	IO304NDB7V3	L9	IO293NDB7V2	M15	GND
K4	IO304PDB7V3	L10	IO307NPB7V4	M16	GND
K5	GAB2/IO308PDB7V4	L11	VCC	M17	GND
K6	IO308NDB7V4	L12	VCC	M18	GND
K7	IO301PDB7V3	L13	VCC	M19	GND
K8	IO301NDB7V3	L14	VCC	M20	VCC
K9	GAC2/IO307PPB7V4	L15	VCC	M21	VCCIB2
K10	VCC	L16	VCC	M22	NC

FG896		FG896		FG896	
Pin Number	A3PE3000 Function	Pin Number	A3PE3000 Function	Pin Number	A3PE3000 Function
M23	IO104PPB2V2	N29	IO107PDB2V3	R5	GFB0/IO274NPB7V0
M24	IO102PDB2V2	N30	IO107NDB2V3	R6	IO271NDB6V4
M25	IO102NDB2V2	P1	IO276NDB7V0	R7	GFB2/IO271PDB6V4
M26	IO95PDB2V1	P2	IO278NDB7V0	R8	IO269PDB6V4
M27	IO97NDB2V1	P3	IO280NDB7V0	R9	IO269NDB6V4
M28	IO101NDB2V2	P4	IO284NDB7V1	R10	VCCIB7
M29	IO103NDB2V2	P5	IO279NDB7V0	R11	VCC
M30	IO119PDB3V0	P6	GFC1/IO275PDB7V0	R12	GND
N1	IO276PDB7V0	P7	GFC0/IO275NDB7V0	R13	GND
N2	IO278PDB7V0	P8	IO277PDB7V0	R14	GND
N3	IO280PDB7V0	P9	IO277NDB7V0	R15	GND
N4	IO284PDB7V1	P10	VCCIB7	R16	GND
N5	IO279PDB7V0	P11	VCC	R17	GND
N6	IO285NDB7V1	P12	GND	R18	GND
N7	IO287NDB7V1	P13	GND	R19	GND
N8	IO281NDB7V0	P14	GND	R20	VCC
N9	IO281PDB7V0	P15	GND	R21	VCCIB2
N10	VCCIB7	P16	GND	R22	GCC0/IO112NDB2V3
N11	VCC	P17	GND	R23	GCB2/IO116PDB3V0
N12	GND	P18	GND	R24	IO118PDB3V0
N13	GND	P19	GND	R25	IO111PPB2V3
N14	GND	P20	VCC	R26	IO122PPB3V1
N15	GND	P21	VCCIB2	R27	GCA0/IO114NPB3V0
N16	GND	P22	GCC1/IO112PDB2V3	R28	VCOMPLC
N17	GND	P23	IO110PDB2V3	R29	GCB1/IO113PPB2V3
N18	GND	P24	IO110NDB2V3	R30	IO115NPB3V0
N19	GND	P25	IO109PPB2V3	T1	IO270NDB6V4
N20	VCC	P26	IO111NPB2V3	T2	VCCPLF
N21	VCCIB2	P27	IO105PDB2V2	T3	GFA2/IO272PPB6V4
N22	IO106NDB2V3	P28	IO105NDB2V2	T4	GFA1/IO273PDB6V4
N23	IO106PDB2V3	P29	GCC2/IO117PDB3V0	T5	IO272NPB6V4
N24	IO108PDB2V3	P30	IO117NDB3V0	T6	IO267NDB6V4
N25	IO108NDB2V3	R1	GFC2/IO270PDB6V4	T7	IO267PDB6V4
N26	IO95NDB2V1	R2	GFB1/IO274PPB7V0	T8	IO265PDB6V3
N27	IO99NDB2V2	R3	VCOMPLF	T9	IO263PDB6V3
N28	IO99PDB2V2	R4	GFA0/IO273NDB6V4	T10	VCCIB6

Package Pin Assignments

FG896		FG896		FG896	
Pin Number	A3PE3000 Function	Pin Number	A3PE3000 Function	Pin Number	A3PE3000 Function
T11	VCC	U17	GND	V23	IO128NDB3V1
T12	GND	U18	GND	V24	IO132PDB3V2
T13	GND	U19	GND	V25	IO130PPB3V2
T14	GND	U20	VCC	V26	IO126NDB3V1
T15	GND	U21	VCCIB3	V27	IO129NDB3V1
T16	GND	U22	IO120PDB3V0	V28	IO127NDB3V1
T17	GND	U23	IO128PDB3V1	V29	IO125NDB3V1
T18	GND	U24	IO124PDB3V1	V30	IO123PDB3V1
T19	GND	U25	IO124NDB3V1	W1	IO266NDB6V4
T20	VCC	U26	IO126PDB3V1	W2	IO262NDB6V3
T21	VCCIB3	U27	IO129PDB3V1	W3	IO260NDB6V3
T22	IO109NPB2V3	U28	IO127PDB3V1	W4	IO252NDB6V2
T23	IO116NDB3V0	U29	IO125PDB3V1	W5	IO251NDB6V2
T24	IO118NDB3V0	U30	IO121NDB3V0	W6	IO251PDB6V2
T25	IO122NPB3V1	V1	IO268NDB6V4	W7	IO255NDB6V2
T26	GCA1/IO114PPB3V0	V2	IO262PDB6V3	W8	IO249PPB6V1
T27	GCB0/IO113NPB2V3	V3	IO260PDB6V3	W9	IO253PDB6V2
T28	GCA2/IO115PPB3V0	V4	IO252PDB6V2	W10	VCCIB6
T29	VCCPLC	V5	IO257NPB6V2	W11	VCC
T30	IO121PDB3V0	V6	IO261NPB6V3	W12	GND
U1	IO268PDB6V4	V7	IO255PDB6V2	W13	GND
U2	IO264NDB6V3	V8	IO259PDB6V3	W14	GND
U3	IO264PDB6V3	V9	IO259NDB6V3	W15	GND
U4	IO258PDB6V3	V10	VCCIB6	W16	GND
U5	IO258NDB6V3	V11	VCC	W17	GND
U6	IO257PPB6V2	V12	GND	W18	GND
U7	IO261PPB6V3	V13	GND	W19	GND
U8	IO265NDB6V3	V14	GND	W20	VCC
U9	IO263NDB6V3	V15	GND	W21	VCCIB3
U10	VCCIB6	V16	GND	W22	IO134PDB3V2
U11	VCC	V17	GND	W23	IO138PDB3V3
U12	GND	V18	GND	W24	IO132NDB3V2
U13	GND	V19	GND	W25	IO136NPB3V2
U14	GND	V20	VCC	W26	IO130NPB3V2
U15	GND	V21	VCCIB3	W27	IO141PDB3V3
U16	GND	V22	IO120NDB3V0	W28	IO135PDB3V2

FG896	
Pin Number	A3PE3000 Function
W29	IO131PDB3V2
W30	IO123NDB3V1
Y1	IO266PDB6V4
Y2	IO250PDB6V2
Y3	IO250NDB6V2
Y4	IO246PDB6V1
Y5	IO247NDB6V1
Y6	IO247PDB6V1
Y7	IO249NPB6V1
Y8	IO245PDB6V1
Y9	IO253NDB6V2
Y10	GEB0/IO235NPB6V0
Y11	VCC
Y12	VCC
Y13	VCC
Y14	VCC
Y15	VCC
Y16	VCC
Y17	VCC
Y18	VCC
Y19	VCC
Y20	VCC
Y21	IO142PPB3V3
Y22	IO134NDB3V2
Y23	IO138NDB3V3
Y24	IO140NDB3V3
Y25	IO140PDB3V3
Y26	IO136PPB3V2
Y27	IO141NDB3V3
Y28	IO135NDB3V2
Y29	IO131NDB3V2
Y30	IO133PDB3V2

5 – Datasheet Information

List of Changes

The following table lists critical changes that were made in each revision of the ProASIC3E datasheet.

Table 1 •

Revision	Changes	Page
Revision 16 (November 2019)	Updated the template change with Microchip-Microsemi logo across the document.	NA
	Removed PQ208 from the A3PE600 device and its related information across the document.	NA
Revision 15 (June 2015)	Updated " ProASIC3E Ordering Information ". Interchanged the positions of Y-Security Feature and I- Application (Temperature Range) (SAR 67296). Added Note "Only devices with package size greater than or equal to 5x5 are supported". Updated Commercial and Industrial Junction Temperatures (SAR 67588).	1-III
	Added the A3PE3000 package to Table 2-5 (SARs 52320 and 58737).	2-5
	Updated " VCCIBx I/O Supply Voltage " (SAR 43323).	3-1
Revision 14 (May 2014)	Added 2 mA and 6 mA I/O short currents values in " I/O Short Currents IOSH/IOSL " (SAR 56295).	2-23 2-25
	Added 2 mA and 6 mA minimum and maximum DC input and output levels in " Minimum and Maximum DC Input and Output Levels "(SAR 56295).	2-26 2-26
	Added 3.3 V LVTTTL / 3.3 V LVCMOS High Slew Commercial-Case Conditions for 2 mA and 6 mA in " 3.3 V LVTTTL / 3.3 V LVCMOS High Slew " (SAR 56295).	
	Added 3.3 V LVTTTL / 3.3 V LVCMOS Low Slew Commercial-Case Conditions for 2 mA and 6 mA in " 3.3 V LVTTTL / 3.3 V LVCMOS Low Slew " (SAR 56295).	
Revision 13 (January 2013)	In the " Features and Benefits " section, updated the Clock Conditioning Circuit (CCC) and PLL Wide Input Frequency Range from '1.5 MHz to 200 MHz' to '1.5MHz to 350 MHz' based on Table 2-98 (SAR 22196).	1-1
	The " ProASIC3E Ordering Information " section has been updated to mention "Y" as "Blank" mentioning "Device Does Not Include License to Implement IP Based on the Cryptography Research, Inc. (CRI) Patent Portfolio" (SAR 43220).	1-III
	Added a note to " Recommended Operating Conditions ¹ " table (SAR 42716): The programming temperature range supported is $T_{ambient} = 0^{\circ}C$ to $85^{\circ}C$.	2-2
	The note in " ProASIC3E CCC/PLL Specification " table referring the reader to SmartGen was revised to refer instead to the online help associated with the core (SAR 42571).	2-73
	Libero Integrated Design Environment (IDE) was changed to Libero System-on-Chip (SoC) throughout the document (SAR 40285). Live at Power-Up (LAPU) has been replaced with 'Instant On'.	NA
Revision 12 (September 2012)	The " Security " section was modified to clarify that Microsemi does not support read-back of programmed data.	1-1

Table 1 •

Revision	Changes	Page
Revision 11 (August 2012)	Added a Note stating "VMV pins must be connected to the corresponding VCCI pins. See the "VMVx I/O Supply Voltage (quiet)" section on page 3-1 for further information." to Table 2-1 • Absolute Maximum Ratings and Table 2-2 • Recommended Operating Conditions ¹ (SAR 38322).	2-1 3-1 2-1
	The drive strength, IOL, and IOH value for 3.3 V GTL and 2.5 V GTL was changed from 25 mA to 20 mA in the following tables (SAR 31924): "Summary of Maximum and Minimum DC Input and Output Levels" table "Summary of I/O Timing Characteristics—Software Default Settings" table "I/O Output Buffer Maximum Resistances ¹ " table "Minimum and Maximum DC Input and Output Levels" table "Minimum and Maximum DC Input and Output Levels" table Also added note stating "Output drive strength is below JEDEC specification" for Tables 2-17 and 2-19. Additionally, the IOL and IOH values for 3.3 V GTL+ and 2.5 V GTL+ were corrected from 51 to 35 (for 3.3 V GTL+) and from 40 to 33 (for 2.5 V GTL+) in table Table 2-13 (SAR 39714).	2-17 2-20 2-21 2-40 2-42
	"Duration of Short Circuit Event Before Failure" table was revised to change the maximum temperature from 110°C to 100°C, with an example of six months instead of three months (SAR 37934).	2-23
	The following sentence was deleted from the "2.5 V LVCMOS" section (SAR 34796): "It uses a 5 V–tolerant input buffer and push-pull output buffer." This change was made in revision 10 and omitted from the change table in error.	2-31
	Revision 11 (continued)	Figure 2-11 was updated to match tables in the "Summary of I/O Timing Characteristics – Default I/O Software Settings" section (SAR 34889).
In Table 2-81 VIL and VIH were revised so that the maximum is 3.6 V for all listed values of VCCI (SAR 37222).		2-54
Figure 2-47 and Figure 2-48 are new (SAR 34848).		2-82
The following sentence was removed from the "VMVx I/O Supply Voltage (quiet)" section in the "Pin Descriptions and Packaging" chapter: "Within the package, the VMV plane is decoupled from the simultaneous switching noise originating from the output buffer VCCI domain" and replaced with "Within the package, the VMV plane biases the input stage of the I/Os in the I/O banks" (SAR 38322). The datasheet mentions that "VMV pins must be connected to the corresponding VCCI pins" for an ESD enhancement.		3-1

Table 1 •

Revision	Changes	Page
Revision 10 (March 2012)	The "In-System Programming (ISP) and Security" section and "Security" section were revised to clarify that although no existing security measures can give an absolute guarantee, Microsemi FPGAs implement the best security available in the industry (SAR 34669).	I, 1-1
	The Y security option and Licensed DPA Logo were added to the "ProASIC3E Ordering Information" section. The trademarked Licensed DPA Logo identifies that a product is covered by a DPA counter-measures license from Cryptography Research (SAR 34727).	III
	The following sentence was removed from the "Advanced Architecture" section: "In addition, extensive on-chip programming circuitry allows for rapid, single-voltage (3.3 V) programming of IGLOOe devices via an IEEE 1532 JTAG interface" (SAR 34689).	1-3
	The "Specifying I/O States During Programming" section is new (SAR 34699).	1-6
	VCCPLL in Table 2-2 • Recommended Operating Conditions ¹ was corrected from "1.4 to 1.6 V" to "1.425 to 1.575 V" (SAR 33851). The T _J symbol was added to the table and notes regarding T _A and T _J were removed. The second of two parameters in the VCCI and VMV row, called "3.3 V DC supply voltage," was corrected to "3.0 V DC supply voltage" (SAR 37227).	2-2
	The reference to guidelines for global spines and VersaTile rows, given in the "Global Clock Contribution—P _{CLOCK} " section, was corrected to the "Spine Architecture" section of the Global Resources chapter in the <i>ProASIC3E FPGA Fabric User's Guide</i> (SAR 34735).	2-10
	t _{DOUT} was corrected to t _{DIN} in Figure 2-3 • Input Buffer Timing Model and Delays (example) (SAR 37109).	2-14
	The typo related to the values for 3.3 V LVCMOS Wide Range in Table 2-17 • Summary of I/O Timing Characteristics—Software Default Settings was corrected (SAR 37227).	2-20
	The notes regarding drive strength in the "Summary of I/O Timing Characteristics – Default I/O Software Settings" section and "3.3 V LVCMOS Wide Range" section and tables were revised for clarification. They now state that the minimum drive strength for the default software configuration when run in wide range is ±100 μA. The drive strength displayed in software is supported in normal range only. For a detailed I/V curve, refer to the IBIS models (SAR 34763).	2-19, 2-28

Table 1 •

Revision	Changes	Page
Revision 10 (continued)	<p>"TBD" for 3.3 V LVCMOS Wide Range in Table 2-19 • I/O Output Buffer Maximum Resistances¹ and Table 2-21 • I/O Short Currents IOSH/IOSL was replaced by "Same as regular 3.3 V LVCMOS" (SAR 33853).</p> <p>3.3 V LVCMOS Wide Range information was separated from regular 3.3 V LVCMOS and placed into its own new section, "3.3 V LVCMOS Wide Range". Values of IOSH and IOSL were added in Table 2-29 • Minimum and Maximum DC Input and Output Levels (SAR 33853).</p> <p>The formulas in the table notes for Table 2-20 • I/O Weak Pull-Up/Pull-Down Resistances were corrected (SAR 34755).</p> <p>The AC Loading figures in the "Single-Ended I/O Characteristics" section were updated to match tables in the "Summary of I/O Timing Characteristics – Default I/O Software Settings" section (SAR 34889).</p> <p>The titles and subtitles for Table 2-31 • 3.3 V LVCMOS Wide Range High Slew and Table 2-32 • 3.3 V LVCMOS Wide Range Low Slew were corrected (SAR 37227).</p> <p>The following notes were removed from Table 2-78 • LVDS Minimum and Maximum DC Input and Output Levels (SAR 34812): $\pm 5\%$ Differential input voltage = ± 350 mV</p> <p>Minimum pulse width High and Low values were added to the tables in the "Global Tree Timing Characteristics" section. The maximum frequency for global clock parameter was removed from these tables because a frequency on the global is only an indication of what the global network can do. There are other limiters such as the SRAM, I/Os, and PLL. SmartTime software should be used to determine the design frequency (SAR 36957).</p> <p>A note was added to Table 2-98 • ProASIC3E CCC/PLL Specification indicating that when the CCC/PLL core is generated by Microsemi core generator software, not all delay values of the specified delay increments are available (SAR 34824).</p> <p>The following figures were deleted. Reference was made to a new application note, Simultaneous Read-Write Operations in Dual-Port SRAM for Flash-Based cSoCs and FPGAs, which covers these cases in detail (SAR 34872). Figure 2-44 • Write Access after Write onto Same Address Figure 2-45 • Read Access after Write onto Same Address Figure 2-46 • Write Access after Read onto Same Address</p> <p>The port names in the SRAM "Timing Waveforms", SRAM "Timing Characteristics" tables, Figure 2-49 • FIFO Reset, and the FIFO "Timing Characteristics" tables were revised to ensure consistency with the software names (SAR 35750).</p> <p>The "Pin Descriptions and Packaging" chapter is new (SAR 34771).</p> <p>Package names used in the "Package Pin Assignments" section were revised to match standards given in Package Mechanical Drawings (SAR 34771).</p> <p>Pin E6 for the FG256 package was corrected from VvB0 to VCCIB0 (SARs 30364, 31597, 26243).</p>	<p>2-21, 2-28</p> <p>2-22</p> <p>2-25</p> <p>2-29, 2-30</p> <p>2-52</p> <p>2-71</p> <p>2-73</p> <p>2-77, 2-78, 2-82, 2-85</p> <p>3-1</p> <p>4-1</p> <p>4-9</p>
July 2010	<p>The versioning system for datasheets has been changed. Datasheets are assigned a revision number that increments each time the datasheet is revised. The "ProASIC3E Device Status" table on page II indicates the status for each device in the device family.</p>	N/A

Revision	Changes	Page														
Revision 9 (Aug 2009) Product Brief v1.2	All references to speed grade –F have been removed from this document.	N/A														
DC and Switching Characteristics v1.3	The "Pro I/Os with Advanced I/O Standards" section was revised to add definitions of hot-swap and cold-sparing.	1-6														
	3.3 V LVCMOS and 1.2 V LVCMOS Wide Range support was added to the datasheet. This affects all tables that contained 3.3 V LVCMOS and 1.2 V LVCMOS data.	N/A														
	IIL and IIH input leakage current information was added to all "Minimum and Maximum DC Input and Output Levels" tables.	N/A														
	–F was removed from the datasheet. The speed grade is no longer supported.	N/A														
	In the Table 2-2 • Recommended Operating Conditions ¹ "3.0 V DC supply voltage" and note 4 are new.	2-2														
	The Table 2-4 • Overshoot and Undershoot Limits ¹ table was updated.	2-3														
	The Table 2-6 • Temperature and Voltage Derating Factors for Timing Delays table was updated.	2-6														
	There are new parameters and data was updated in the Table 2-99 • RAM4K9 table.	2-79														
There are new parameters and data was updated in the Table 2-100 • RAM512X18 table.	2-80															
Revision 8 (Feb 2008) Product Brief v1.1	Table 1-2 • ProASIC3E FPGAs Package Sizes Dimensions is new.	1-II														
Revision 7 (Jun 2008) DC and Switching Characteristics v1.2	The title of Table 2-4 • Overshoot and Undershoot Limits ¹ was modified to remove "as measured on quiet I/Os." Table note 2 was revised to remove "estimated SSO density over cycles." Table note 3 was deleted.	2-3														
	Table 2-78 • LVDS Minimum and Maximum DC Input and Output Levels was updated.	2-52														
Revision 6 (Jun 2008)	The A3PE600 "FG484" table was missing G22. The pin and its function were added to the table.	4-25														
Revision 5 (Jun 2008) Packaging v1.4	The naming conventions changed for the following pins in the "FG484" for the A3PE600: <table border="0"> <thead> <tr> <th>Pin Number</th> <th>New Function Name</th> </tr> </thead> <tbody> <tr> <td>J19</td> <td>IO45PPB2V1</td> </tr> <tr> <td>K20</td> <td>IO45NPB2V1</td> </tr> <tr> <td>M2</td> <td>IO114NPB6V1</td> </tr> <tr> <td>N1</td> <td>IO114PPB6V1</td> </tr> <tr> <td>N4</td> <td>GFC2/IO115PPB6V1</td> </tr> <tr> <td>P3</td> <td>IO115NPB6V1</td> </tr> </tbody> </table>	Pin Number	New Function Name	J19	IO45PPB2V1	K20	IO45NPB2V1	M2	IO114NPB6V1	N1	IO114PPB6V1	N4	GFC2/IO115PPB6V1	P3	IO115NPB6V1	4-20
Pin Number	New Function Name															
J19	IO45PPB2V1															
K20	IO45NPB2V1															
M2	IO114NPB6V1															
N1	IO114PPB6V1															
N4	GFC2/IO115PPB6V1															
P3	IO115NPB6V1															
Revision 4 (Apr 2008) Product Brief v1.0	The product brief portion of the datasheet was divided into two sections and given a version number, starting at v1.0. The first section of the document includes features, benefits, ordering information, and temperature and speed grade offerings. The second section is a device family overview.	N/A														
	Packaging v1.3	The "FG324" package diagram was replaced.	4-10													

Revision	Changes	Page
Revision 3 (Apr 2008) Packaging v1.2	The following pins had duplicates and the extra pins were deleted from the "PQ208" A3PE3000 table: 36, 62, 171 Note: There were no pin function changes in this update.	4-2
	The following pins had duplicates and the extra pins were deleted from the "FG324" table: E2, E3, E16, E17, P2, P3, T16, U17 Note: There were no pin function changes in this update.	4-10
	The "FG256" pin table was updated for the A3PE600 device because the old PAT were based on the IFX die, and this is the final UMC die version.	4-7
	The "FG484" was updated for the A3PE600 device because the old PAT were based on the IFX die, and this is the final UMC die version.	4-20
	The following pins had duplicates and the extra pins were deleted from the "FG896" table: AD6, AE5, AE28, AF29, F5, F26, G6, G25 Note: There were no pin function changes in this update.	4-39
Revision 2 (Mar 2008) Product Brief rev. 1	The FG324 package was added to the "ProASIC3E Product Family" table, the "I/Os Per Package1" table, and the "Temperature Grade Offerings" table for A3PE3000.	I, II, IV
Revision 1 (Feb 2008) DC and Switching Characteristics v1.1	In Table 2-3 • Flash Programming Limits – Retention, Storage and Operating Temperature 1 , Maximum Operating Junction Temperature was changed from 110°C to 100°C for both commercial and industrial grades.	2
	The " PLL Behavior at Brownout Condition " section is new.	2-4
	In the " PLL Contribution—PPLL " section, the following was deleted: FCLKIN is the input clock frequency.	2-11
	In Table 2-14 • Summary of Maximum and Minimum DC Input Levels , the note was incorrect. It previously said T _J and it was corrected and changed to T _A .	2-18
	In Table 2-98 • ProASIC3E CCC/PLL Specification , the SCLK parameter and note 1 are new.	2-73
	Table 2-103 • JTAG 1532 was populated with the parameter data, which was not in the previous version of the document.	2-83
Revision 1 (cont'd) Packaging v1.1	The "PQ208" pin table for A3PE3000 was updated.	4-2
	The "FG324" pin table for A3PE3000 is new.	4-11
	The "FG484" pin table for A3PE3000 is new.	4-15
	The "FG896" pin table for A3PE3000 is new.	4-39
Revision 0 (Jan 2008)	This document was previously in datasheet v2.1. As a result of moving to the handbook format, Actel has restarted the version numbers. The new version number is 51700098-001-0.	N/A
v2.1 (July 2007)	CoreMP7 information was removed from the " Features and Benefits " section.	1-1
	The M1 device part numbers have been updated in ProASIC3E Product Family, "Packaging Tables", "Temperature Grade Offerings", "Speed Grade and Temperature Grade Matrix", and "Speed Grade and Temperature Grade Matrix".	1-1

Revision	Changes	Page
v2.1 (continued)	The words "ambient temperature" were added to the temperature range in the "Temperature Grade Offerings", "Speed Grade and Temperature Grade Matrix", and "Speed Grade and Temperature Grade Matrix" sections.	1-1
	The "Clock Conditioning Circuit (CCC) and PLL" section was updated.	1-1
	The caption "Main (chip)" in Figure 2-9 • Overview of Automotive ProASIC3 VersaNet Global Network was changed to "Chip (main)."	2-9
	The T_J parameter in Table 3-2 • Recommended Operating Conditions was changed to T_A , ambient temperature, and table notes 4–6 were added.	3-2
	The "PLL Macro" section was updated to add information on the VCO and PLL outputs during power-up.	2-15
v2.0 (April 2007)	In the "Temperature Grade Offerings" section, Ambient was deleted.	iii
	Ambient was deleted from "Temperature Grade Offerings".	iii
	Ambient was deleted from the "Speed Grade and Temperature Grade Matrix".	iv
	The "PLL Macro" section was updated to include power-up information.	2-15
	Table 2-13 • ProASIC3E CCC/PLL Specification was updated.	2-30
	Figure 2-19 • Peak-to-Peak Jitter Definition is new.	2-18
	The "SRAM and FIFO" section was updated with operation and timing requirement information.	2-21
	The "RESET" section was updated with read and write information.	2-25
	The "RESET" section was updated with read and write information.	2-25
	The "Introduction" in the "Advanced I/Os" section was updated to include information on input and output buffers being disabled.	2-28
	In the Table 2-15 • Levels of Hot-Swap Support, the ProASIC3 compliance descriptions were updated for levels 3 and 4.	2-34
	Table 2-45 • I/O Hot-Swap and 5 V Input Tolerance Capabilities in ProASIC3E Devices was updated.	2-64
	Notes 3, 4, and 5 were added to Table 2-17 • Comparison Table for 5 V–Compliant Receiver Scheme. 5 x 52.72 was changed to 52.7 and the Maximum current was updated from 4 x 52.7 to 5 x 52.7.	2-40
	The "VCCPLF PLL Supply Voltage" section was updated.	2-50
	The "VPUMP Programming Supply Voltage" section was updated.	2-50
	The "GL Globals" section was updated to include information about direct input into quadrant clocks.	2-51
	VJTAG was deleted from the "TCK Test Clock" section.	2-51
	In Table 2-22 • Recommended Tie-Off Values for the TCK and TRST Pins, TSK was changed to TCK in note 2. Note 3 was also updated.	2-51
	Ambient was deleted from Table 3-2 • Recommended Operating Conditions. VPUMP programming mode was changed from "3.0 to 3.6" to "3.15 to 3.45".	3-2
	Note 3 is new in Table 3-4 • Overshoot and Undershoot Limits (as measured on quiet I/Os).	3-2
In EQ 3-2, 150 was changed to 110 and the result changed to 5.88.	3-5	

Revision	Changes	Page
v2.0 (continued)	Table 3-6 • Temperature and Voltage Derating Factors for Timing Delays was updated.	3-5
	Table 3-5 • Package Thermal Resistivities was updated.	3-5
	Table 3-10 • Different Components Contributing to the Dynamic Power Consumption in ProASIC3E Devices was updated.	3-8
	t_{WRO} and t_{CCKH} were added to Table 3-94 • RAM4K9 and Table 3-95 • RAM512X18.	3-74 to 3-74
	The note in Table 3-24 • I/O Input Rise Time, Fall Time, and Related I/O Reliability was updated.	3-23
	Figure 3-43 • Write Access After Write onto Same Address, Figure 3-44 • Read Access After Write onto Same Address, and Figure 3-45 • Write Access After Read onto Same Address are new.	3-71 to 3-73
	Figure 3-53 • Timing Diagram was updated.	3-80
	Notes were added to the package diagrams identifying if they were top or bottom view.	N/A
	The A3PE1500 "208-Pin PQFP" table is new.	4-4
	The A3PE1500 "484-Pin FBGA" table is new.	4-18
	The A3PE1500 "A3PE1500 Function" table is new.	4-24
Advance v0.6 (January 2007)	In the "Packaging Tables" table, the number of I/Os for the A3PE1500 was changed for the FG484 and FG676 packages.	ii
Advance v0.5 (April 2006)	B-LVDS and M-LDVS are new I/O standards added to the datasheet.	N/A
	The term flow-through was changed to pass-through.	N/A
	Figure 2-8 • Very-Long-Line Resources was updated.	2-8
	The footnotes in Figure 2-27 • CCC/PLL Macro were updated.	2-28
	The Delay Increments in the Programmable Delay Blocks specification in Figure 2-24 • ProASIC3E CCC Options.	2-24
	The "SRAM and FIFO" section was updated.	2-21
	The "RESET" section was updated.	2-25
	The "WCLK and RCLK" section was updated.	2-25
	The "RESET" section was updated.	2-25
	The "RESET" section was updated.	2-27
	B-LVDS and M-LDVS are new I/O standards added to the datasheet.	N/A
	The term flow-through was changed to pass-through.	N/A
	Figure 2-8 • Very-Long-Line Resources was updated.	2-8
	The footnotes in Figure 2-27 • CCC/PLL Macro were updated.	2-28
	The Delay Increments in the Programmable Delay Blocks specification in Figure 2-24 • ProASIC3E CCC Options.	2-24
	The "SRAM and FIFO" section was updated.	2-21
	The "RESET" section was updated.	2-25
	The "WCLK and RCLK" section was updated.	2-25

Revision	Changes	Page
Advance v0.5 (continued)	The "RESET" section was updated.	2-25
	The "RESET" section was updated.	2-27
	The "Introduction" of the "Introduction" section was updated.	2-28
	PCI-X 3.3 V was added to the Compatible Standards for 3.3 V in Table 2-11 • VCCI Voltages and Compatible Standards	2-29
	Table 2-35 • ProASIC3E I/O Features was updated.	2-54
	The "Double Data Rate (DDR) Support" section was updated to include information concerning implementation of the feature.	2-32
	The "Electrostatic Discharge (ESD) Protection" section was updated to include testing information.	2-35
	Level 3 and 4 descriptions were updated in Table 2-43 • I/O Hot-Swap and 5 V Input Tolerance Capabilities in ProASIC3 Devices.	2-64
	The notes in Table 2-45 • I/O Hot-Swap and 5 V Input Tolerance Capabilities in ProASIC3E Devices were updated.	2-64
	The "Simultaneous Switching Outputs (SSOs) and Printed Circuit Board Layout" section is new.	2-41
	A footnote was added to Table 2-37 • Maximum I/O Frequency for Single-Ended and Differential I/Os in All Banks in ProASIC3E Devices (maximum drive strength and high slew selected).	2-55
	Table 2-48 • ProASIC3E I/O Attributes vs. I/O Standard Applications	2-81
	Table 2-55 • ProASIC3 I/O Standards—SLEW and Output Drive (OUT_DRIVE) Settings	2-85
	The "x" was updated in the "Pin Descriptions" section.	2-50
	The "VCC Core Supply Voltage" pin description was updated.	2-50
	The "VMVx I/O Supply Voltage (quiet)" pin description was updated to include information concerning leaving the pin unconnected.	2-50
	EXTFB was removed from Figure 2-24 • ProASIC3E CCC Options.	2-24
	The CCC Output Peak-to-Peak Period Jitter F_{CCC_OUT} was updated in Table 2-13 • ProASIC3E CCC/PLL Specification.	2-30
	EXTFB was removed from Figure 2-27 • CCC/PLL Macro.	2-28
	The LVPECL specification in Table 2-45 • I/O Hot-Swap and 5 V Input Tolerance Capabilities in ProASIC3E Devices was updated.	2-64
	Table 2-15 • Levels of Hot-Swap Support was updated.	2-34
	The "Cold-Sparing Support" section was updated.	2-34
	"Electrostatic Discharge (ESD) Protection" section was updated.	2-35
	The VJTAG and I/O pin descriptions were updated in the "Pin Descriptions" section.	2-50
	The "VJTAG JTAG Supply Voltage" pin description was updated.	2-50
	The "VPUMP Programming Supply Voltage" pin description was updated to include information on what happens when the pin is tied to ground.	2-50

Revision	Changes	Page
Advance v0.5 (continued)	The "I/O User Input/Output" pin description was updated to include information on what happens when the pin is unused.	2-50
	The "JTAG Pins" section was updated to include information on what happens when the pin is unused.	2-51
	The "Programming" section was updated to include information concerning serialization.	2-53
	The "JTAG 1532" section was updated to include SAMPLE/PRELOAD information.	2-54
	The "DC and Switching Characteristics" chapter was updated with new information.	Starting on page 3-1
	Table 3-6 was updated.	3-5
	In Table 3-10, PAC4 was updated.	3-8
	Table 3-19 was updated.	3-20
	The note in Table 3-24 was updated.	3-23
	All Timing Characteristics tables were updated from LVTTL to Register Delays	3-26 to 3-64
	The Timing Characteristics for RAM4K9, RAM512X18, and FIFO were updated.	3-74 to 3-79
	F_{TCKMAX} was updated in Table 3-98.	3-80
Advance v0.4 (October 2005)	The "Packaging Tables" table was updated.	ii
Advance v0.3	Figure 2-11 was updated.	2-9
	The "Clock Resources (VersaNets)" section was updated.	2-9
	The "VersaNet Global Networks and Spine Access" section was updated.	2-9
	The "PLL Macro" section was updated.	2-15
	Figure 2-27 was updated.	2-28
	Figure 2-20 was updated.	2-19
	Table 2-5 was updated.	2-25
	Table 2-6 was updated.	2-25
	The "FIFO Flag Usage Considerations" section was updated.	2-27
	Table 2-33 was updated.	2-51
	Figure 2-24 was updated.	2-31
	The "Cold-Sparing Support" section is new.	2-34
	Table 2-45 was updated.	2-64
	Table 2-48 was updated.	2-81
	Pin descriptions in the "JTAG Pins" section were updated.	2-51
	The "Pin Descriptions" section was updated.	2-50
	Table 3-7 was updated.	3-6

Revision	Changes	Page
Advance v0.3 (continued)	The "Methodology" section was updated.	3-9
	The A3PE3000 "208-Pin PQFP" pin table was updated.	4-6

Datasheet Categories

Categories

In order to provide the latest information to designers, some datasheet parameters are published before data has been fully characterized from silicon devices. The data provided for a given device, as highlighted in the "[ProASIC3E Device Status](#)" table on page II, is designated as either "Product Brief," "Advance," "Preliminary," or "Production." The definitions of these categories are as follows:

Product Brief

The product brief is a summarized version of a datasheet (advance or production) and contains general product information. This document gives an overview of specific device and family information.

Advance

This version contains initial estimated information based on simulation, other products, devices, or speed grades. This information can be used as estimates, but not for production. This label only applies to the DC and Switching Characteristics chapter of the datasheet and will only be used when the data has not been fully characterized.

Preliminary

The datasheet contains information based on simulation and/or initial characterization. The information is believed to be correct, but changes are possible.

Production

This version contains information that is considered to be final.

Export Administration Regulations (EAR)

The products described in this document are subject to the Export Administration Regulations (EAR). They could require an approved export license prior to export from the United States. An export includes release of product or disclosure of technology to a foreign national inside or outside the United States.

Safety Critical, Life Support, and High-Reliability Applications Policy

The products described in this advance status document may not have completed the Microsemi qualification process. Products may be amended or enhanced during the product introduction and qualification process, resulting in changes in device functionality or performance. It is the responsibility of each customer to ensure the fitness of any product (but especially a new product) for a particular purpose, including appropriateness for safety-critical, life-support, and other high-reliability applications. Consult the Microsemi SoC Products Group Terms and Conditions for specific liability exclusions relating to life-support applications. A reliability report covering all of the SoC Products Group's products is available at [Microsemi SoC Reliability Report](#). Microsemi also offers a variety of enhanced qualification and lot acceptance screening procedures. Contact your local sales office for additional reliability information.



a  MICROCHIP company

Microsemi Headquarters

One Enterprise, Aliso Viejo,
CA 92656 USA

Within the USA: +1 (800) 713-4113

Outside the USA: +1 (949) 380-6100

Sales: +1 (949) 380-6136

Fax: +1 (949) 215-4996

Email: sales.support@microsemi.com

www.microsemi.com

©2019 Microsemi, a wholly owned subsidiary of Microchip Technology Inc. All rights reserved. Microsemi and the Microsemi logo are registered trademarks of Microsemi Corporation. All other trademarks and service marks are the property of their respective owners.

Microsemi makes no warranty, representation, or guarantee regarding the information contained herein or the suitability of its products and services for any particular purpose, nor does Microsemi assume any liability whatsoever arising out of the application or use of any product or circuit. The products sold hereunder and any other products sold by Microsemi have been subject to limited testing and should not be used in conjunction with mission-critical equipment or applications. Any performance specifications are believed to be reliable but are not verified, and Buyer must conduct and complete all performance and other testing of the products, alone and together with, or installed in, any end-products. Buyer shall not rely on any data and performance specifications or parameters provided by Microsemi. It is the Buyer's responsibility to independently determine suitability of any products and to test and verify the same. The information provided by Microsemi hereunder is provided "as is, where is" and with all faults, and the entire risk associated with such information is entirely with the Buyer. Microsemi does not grant, explicitly or implicitly, to any party any patent rights, licenses, or any other IP rights, whether with regard to such information itself or anything described by such information. Information provided in this document is proprietary to Microsemi, and Microsemi reserves the right to make any changes to the information in this document or to any products and services at any time without notice.

About Microsemi

Microsemi, a wholly owned subsidiary of Microchip Technology Inc. (Nasdaq: MCHP), offers a comprehensive portfolio of semiconductor and system solutions for aerospace & defense, communications, data center and industrial markets. Products include high-performance and radiation-hardened analog mixed-signal integrated circuits, FPGAs, SoCs and ASICs; power management products; timing and synchronization devices and precise time solutions, setting the world's standard for time; voice processing devices; RF solutions; discrete components; enterprise storage and communication solutions, security technologies and scalable anti-tamper products; Ethernet solutions; Power-over-Ethernet ICs and midspans; as well as custom design capabilities and services. Learn more at www.microsemi.com.

Looking for pricing, stock, or lifecycle information?

Click below to explore more details on WIN SOURCE:

 [View A3PE3000-FG896I on WIN SOURCE](#)

 [Microchip Technology](#) Information

Optimize Your Supply Chain with WIN SOURCE Solutions

-  Global Sourcing Solution
-  Obsolete Management
-  Cost Control Management
-  Shortage Management
-  Alternative Solution
-  Excess Inventory Management